

Index 450-210 Series Florida-U Beams

Design Criteria

AASHTO LRFD Bridge Design Specifications; Structures Detailing Manual (SDM); Structures Design Guidelines (SDG)

Design Assumptions and Limitations

Index 450-210 is the lead standard for the Florida-U Beam standard series which includes Indexes 450-210 through 450-272. Use this standard with Indexes 450-248, 450-254, 450-263, 450-272, 450-299 and 450-502.

The standard Florida-U Beams are applicable for spans with skewed end conditions less than or equal to 15 degrees. For beams with skewed end conditions greater than 15 degrees the EOR shall develop a custom design and details using the standards as a basis.

These standards must be supplemented with project specific information including a Table of Beam Variables, Strand Pattern Details and a Strand Debonding Legend which must be completed and included in the Structures Plans. These standards and the supplemental project specific information that is included in the plans provide sufficient information to permit beam fabrication without the submittal of shop drawings.

Data tables for associated Indexes 450-299 and 450-502 must also be completed and included in the plans.

Florida-U Beams are typically placed parallel to the cross slope of the bridge deck.

The prestressed beams in these Standard Drawings are generally assumed to act as simple spans under both Dead Load and Live Load even where the deck is detailed to be continuous across the intermediate supports.

When the total initial tensioning force of the fully bonded strands required by design exceeds the values shown below, shield additional strands at the end of the beam when possible. The end reinforcement may only be redesigned to accommodate an increased vertical splitting force when approved by the State Structures Design Office. If approval is granted, Index 450-210 and the appropriate Standard Plans Detail Drawings must then be modified for inclusion in the contract documents and signed and sealed by the EOR.

To limit vertical splitting forces in the webs of beams, the maximum prestress force at the beam ends from fully bonded strands must be limited to the following:

Index No.	Beam Type	Max. Bonded Prestress Force	Last Revision Date
450-248	Florida-U 48	2790 Kips	07/01/05
450-254	Florida-U 54	2790 Kips	07/01/05
450-263	Florida-U 63	3070 Kips	07/01/05
450-272	Florida-U 72	3070 Kips	07/01/05

Do not apply losses and use the jacking force of all the strands located in the bottom half of the beam when calculating the Bonded Prestress Force.

Stay-In-Place Metal Forms are required to be used to form the deck within the individual Florida-U Beams.

Due to the absence of external end diaphragms between individual Florida-U Beams, a thickened deck edge beam at deck expansion joints is required to support wheel loads. Generally, the depth of the Edge Beam shall extend from the top of the deck to the bottom face of the top flanges of the Florida-U Beams.

Plan Content Requirements

In the Structures Plans:

Complete the following "FLORIDA-U BEAM - TABLE OF BEAM VARIABLES" and include it in the plans. Use additional sheets when the actual number of beams or strand patterns exceeds the capacity of a single plan sheet using the standard table. Supplemental details and modifications are permitted if special conditions require dimensions, details or notes. However, the "FLORIDA-U BEAM - TABLE OF BEAM VARIABLES" itself should not be modified. See **FDM 115** for more information regarding use of Data Tables.

Place strands in configurations to distribute stress in the ends of beams and minimize potential for diaphragm cracking.

Report elastic and time dependent shortening effects (DIM R) at the top of the beam @ 120 days. The average of the calculated values for the top and bottom of the beam may be used.

Report DIM P for beams placed on grade if the calculated value is equal or greater than 1" using 1/8" increments.

Round Angle Φ up to the nearest degree.

Specify shear stirrup spacings V1 and V2 for Bars 5K to the nearest inch.

Show fully bonded strands in the following locations to support Bars D:

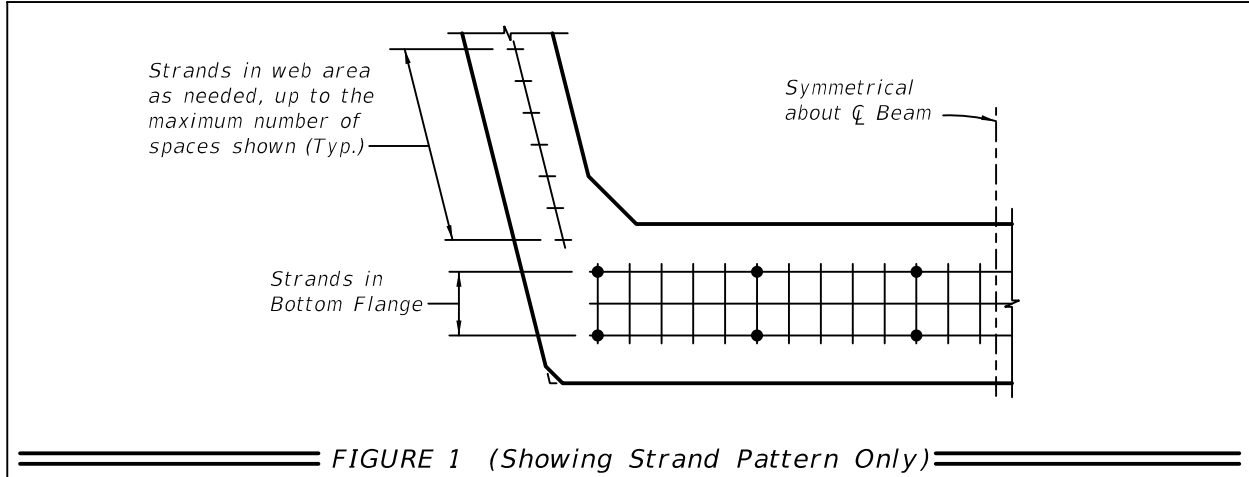

Prepare a Framing Plan for bridges meeting the criteria stated in the SDM.

Show Stay-In-Place Metal Form details for the forms within the individual Florida-U Beams.

Design and detail a thickened deck edge beam at deck expansion joints between individual Florida-U Beams.

Payment

Item number	Item Description	Unit Measure
450-4-AAA	Prestressed Beam - FL U-Beam	LF

Example Problem

The following example shows the data required for completion of a Florida-U Beam Table of Beam Variables. The example assumes a two span bridge with Florida-U 72 Beams designed for the following conditions:

Live Load: HL-93

Future Wearing Surface: Design includes allowance for 15 PSF.

Stay-in-Place Metal Forms: Design includes allowance for 20 PSF non-composite dead load over the projected plan area of the forms for the unit weight of metal forms and concrete required to fill the form flutes.

Environment (Superstructure): Moderately Aggressive

Bridge Characteristics:

Length: 249'-4"

Width: 59'-1" (out-to-out)

Clear Roadway: 56'-0"

Superstructure:

Two simple spans of prestressed concrete beams with 8-inch composite deck slab

Span: 124'-8", 124'-8"

Sidewalk: None

Horizontal Alignment: Straight

Vertical Alignment: 0.00% Grade

Skew Angle: 0 degrees

Beam Design:

Beam: Florida-U 72 Beam

Spacing: 21'-0"

Design Span Length: 122'-4"

Composite Dead Load

(per girder): 603 PLF

Non-Composite Dead Load:

124'-8" Span: 4163 PLF

Diaphragm Dead Load:

End: 8.6 kips each
Intermediate: 4.3 kips each

Bonded Strand Development Multiplier = 1.60

Tension Stress Limits at Release as per SDG Live Load Distribution Factors
(interior beam):

Shear: 1.50
Moment: 1.50

FLORIDA-U BEAM - TABLE OF BEAM VARIABLES																															
FUB TYPE	LOCATION		CONCRETE PROPERTIES		STND. PTRN. TYPE	END ELEV. COND.	PLAN VIEW CASE		BRG. PLATE MARK ***		END OF BEAM AND BEARING DIMENSIONS **				BEAM DIMENSIONS *		REINFORCING STEEL														
	SPAN NO.	BEAM NO.	CLASS	STRENGTHS (psi)			END 1	END 2	END 1	END 2	END 1	END 2	ANGLE θ		DIM P	DIM J	DIM K1	DIM K2	DIM L	DIM R	4G NO.	4H NO.	4M NO.	5K NO.	NO. OF SPACES BARS 5K & 4M			SPACING BARS 5K & 4M *			
				28 Day									Release	END 1											END 2	END 1	END 2	END 1	END 2	S1	S2
72	1	1 to 3	VI	8500	6000	1	1	1	1			90°	90°	0"	10½"	1'-2¾"	1'-2"	124'-3½"	2½"	42	84	382	410	30	21	1	9"	1'-0"	1'-1¾"		
72	2	1 to 3	VI	8500	6000	1	1	1	1			90°	90°	0"	10½"	1'-2"	1'-2¾"	124'-3½"	2½"	42	84	382	410	30	21	1	9"	1'-0"	1'-1¾"		

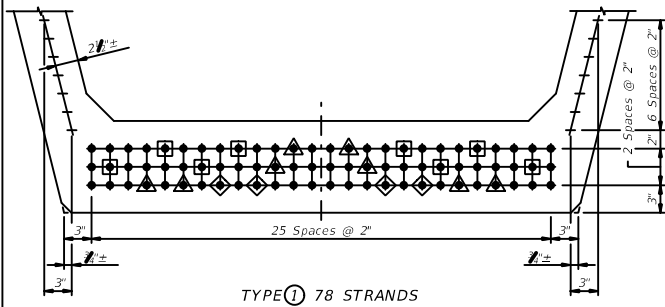

STRAND DESCRIPTION: Use 0.60" Diameter, Grade 270, Low Relaxation Carbon Steel Strands stressed at 43.94 kips each. Area per strand equals 0.217 sq. in.
 STRAND PATTERN

NOTE:
 Work this sheet with Standard Plans Index
 450-210, 450-248, 450-254, 450-263 and 450-272.

DIMENSION NOTES
 * All longitudinal beam dimensions shown on this sheet with a single asterisk (*) are measured along the top of beam at the centerline of beam.
 ** End of beam bearing dimensions "J" and "K" are measured along the bottom of the beam.

BEARING PLATES
 *** Mark indicates beveled bearing plate and embedded bearing plate required. See Index 450-502 for details.

STRAND DEBONDING LEGEND
 • - fully bonded strands.
 □ - strands debonded 21'-0" from end of beam.
 △ - strands debonded 24'-0" from end of beam.
 ◇ - strands debonded 27'-6" from end of beam.

NOTE: On beams with skewed ends the debonded length shall be measured along the shielded strand.

REVISIONS						STATE OF FLORIDA DEPARTMENT OF TRANSPORTATION				SHEET TITLE:		REF. DES. NO.
DATE	BY	DESCRIPTION	DATE	BY	DESCRIPTION	ROAD NO.	COUNTY	FINANCIAL PROJECT ID	PROJECT NAME	SAMPLE		SHEET NO.

Design Aids

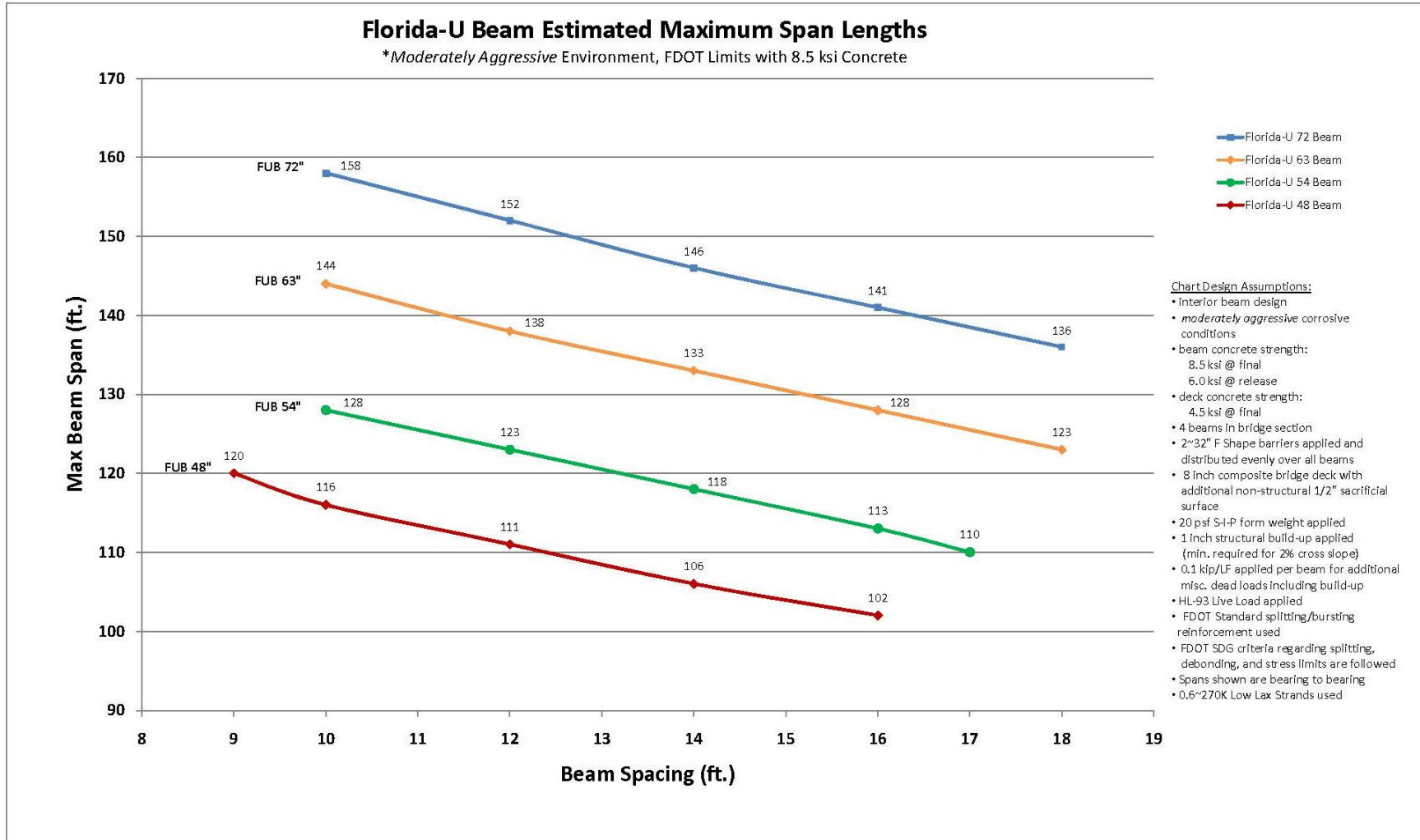

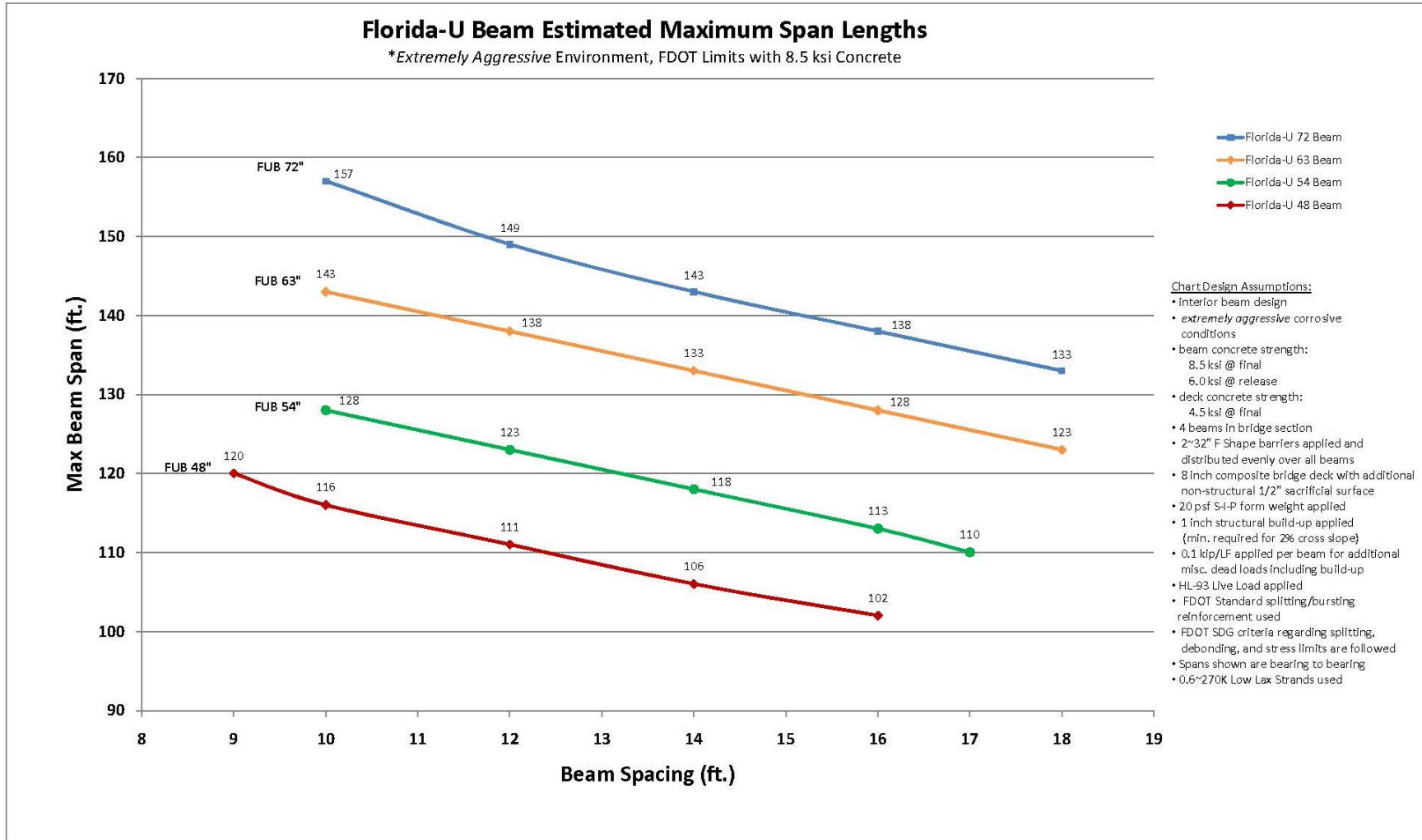

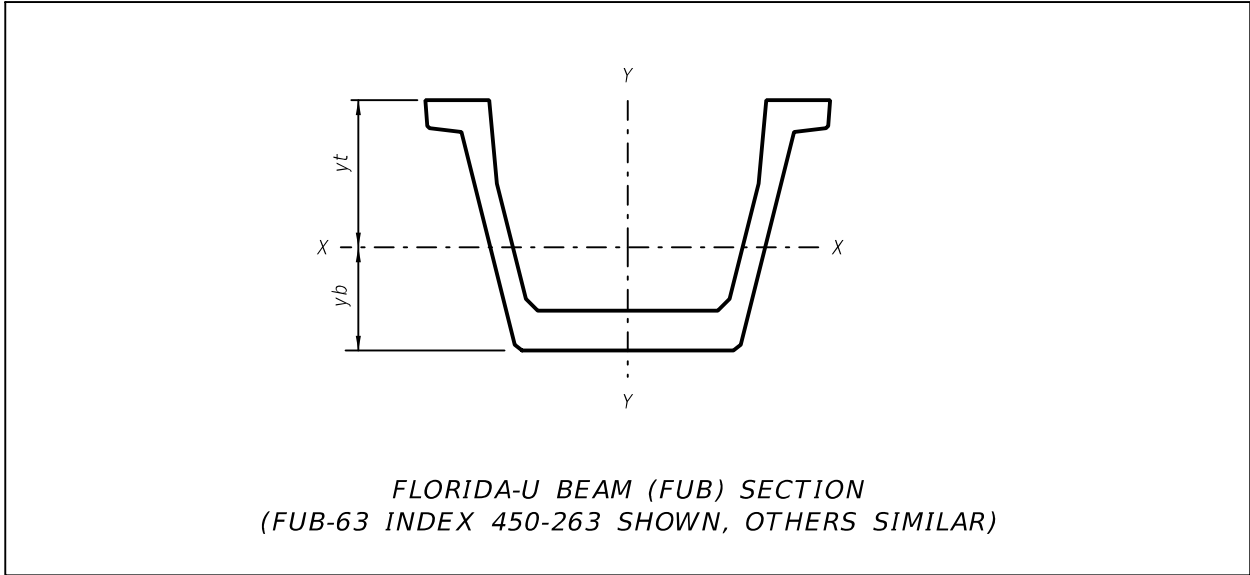

Section Properties					
Beam Size	Area (in.²)	I_{xx} (in.⁴)	I_{yy} (in.⁴)	yt (in.)	yb (in.)
FUB-48	1,206	321,222	905,815	28.53	19.47
FUB-54	1,275	439,370	1.026 x 10 ⁶	31.99	22.01
FUB-63	1,377	659,103	1.222 x 10 ⁶	37.08	25.92
FUB-72	1,479	933,707	1.438 x 10 ⁶	42.09	29.91