

GENERAL NOTES:

1. Meet the requirements of Specification 700.
2. Furnish and install the Dynamic Message Sign (DMS), sign structure in accordance with Index 700-040 or 700-041. Locate foundations at locations shown in the Plans.
3. Shop Drawings are required:
 - A. Include the DMS connection
 - B. Do not start fabrication until the shop drawings are approved
4. If required, install guardrail at location show in the Plans and in accordance with Index 536-001.
5. Installation:
 - A. See project requirements for location of DMS Cabinet.
 - B. Field Adjust pole-mounted DMS cabinet height to achieve best access for maintenance personnel given site condition as directed by the Engineer. Avoid conflicts with stiffeners, handhole and maintenance of anchor bolts.
 - C. Locate the sign horizontal on the structure as shown in the Plans. Vertically center the sign enclosure with the centerline of the truss.
 - D. Before erection, field drill the bolt holes in the vertical hangers and horizontal mounting member attached to the sign enclosure. Field locate holes to allow vertical hanger placement as shown on the Plans with no conflicts with gusset or splice plates.
 - E. Locate threaded couplings on sign side of upright above the sign truss
 - F. Connect grounding conductors to the steel framework that has been cleaned to base metal by use of bonding plates having contact area of not less than 8 square inches or by welding or brazing. Drilling and tapping the steel structure to accept a threaded connector is also an acceptable method
 - G. If steel framework is to be drilled and tapped to accept threaded connector, the threaded connector shall be galvanized and have at least 5 threads fully engaged and secured with a jam nut to the steel framework.
 - H. Bends in the conduit must be greater than the minimum bending radius for the cable contained in the conduit.
 - I. Completely encase all data, fiber optic and power cables for the DMS within the sign structure or in conduit.
 - J. Permanently stamp/mark foundation to indicate conduit locations.
 - K. Transition conduit in foundation to indicate underground conduit with appropriate reducer outside the limits of the foundation.
6. Materials (Sign Mounting Components):
 - A. Aluminum Structural Shapes: ASTM B221, Alloy 6061-T6
 - B. Vertical Hangers: ASTM A709, Grade 36
 - C. U-Bolts: ASTM A449 or A193 B7
 - D. Steel Bolts, Nuts, and Washers:
 1. High Strength Bolts: ASTM F3125, Grade A325, Type 1
 2. Nuts: ASTM F563
 3. Washers: ASTM F463 (Flat Washer)

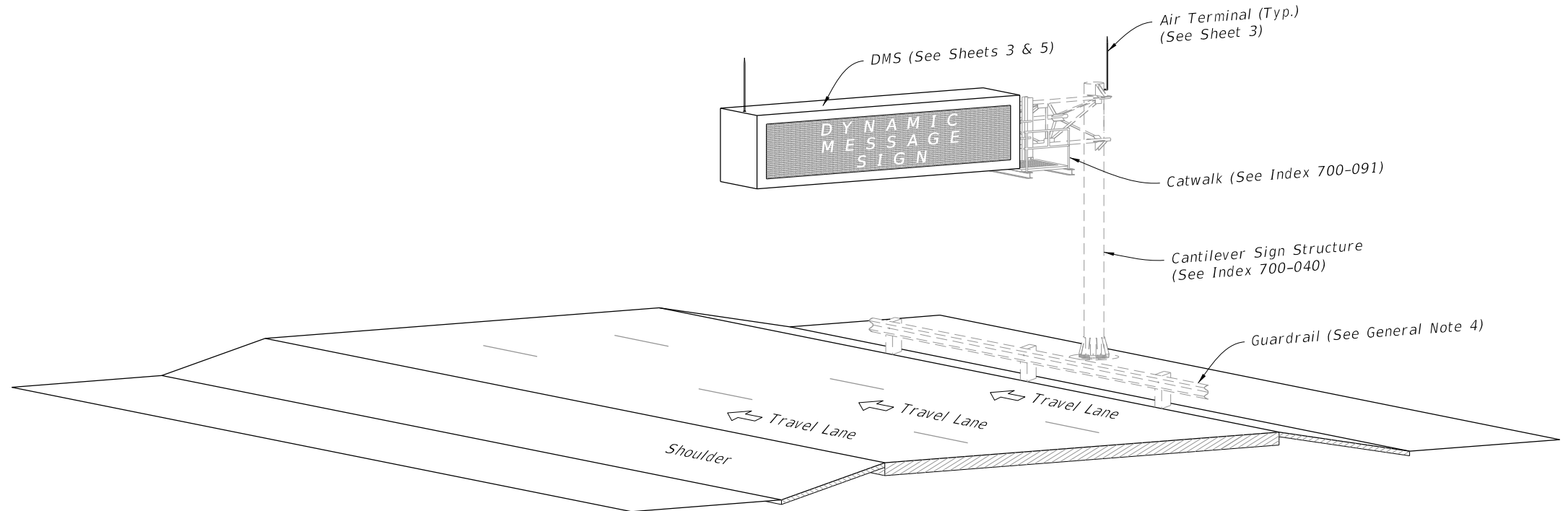

CANTILEVER ISOMETRIC VIEW

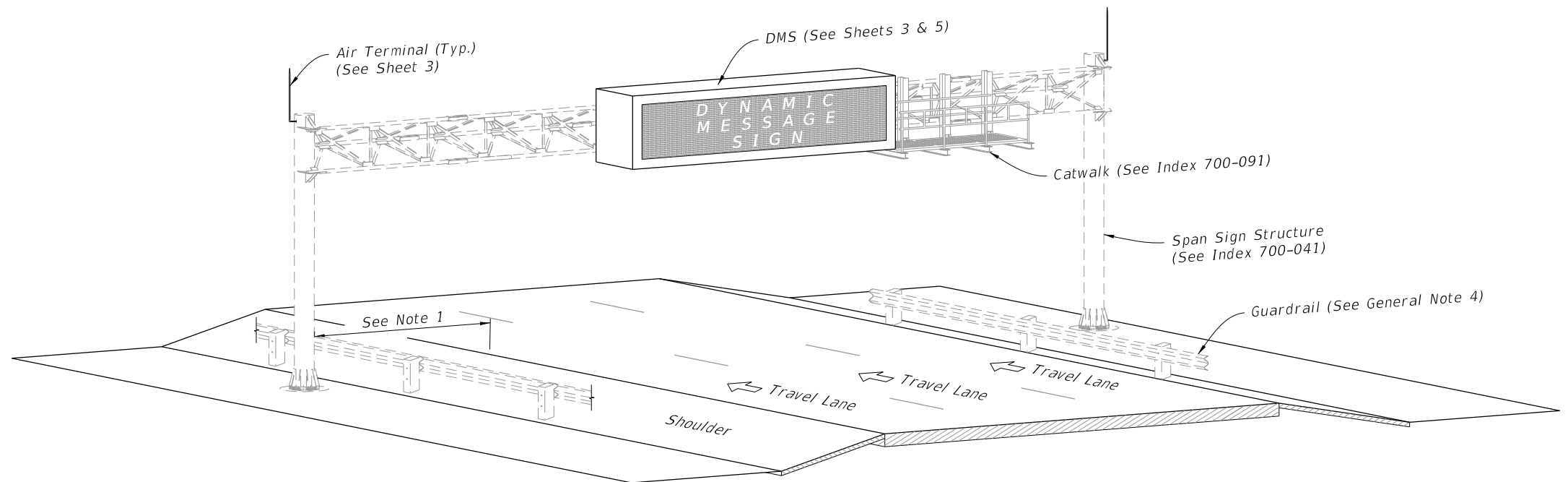

SPAN ISOMETRIC VIEW

DYNAMIC MESSAGE SIGN ASSEMBLY

9/29/2025 7:28:47 AM

LAST REVISION 11/01/22	REVISION	DESCRIPTION:	 FY 2026-27 STANDARD PLANS	DYNAMIC MESSAGE SIGN WALK-IN	INDEX 700-090	SHEET 1 of 5
---------------------------	----------	--------------	---	------------------------------	------------------	-----------------

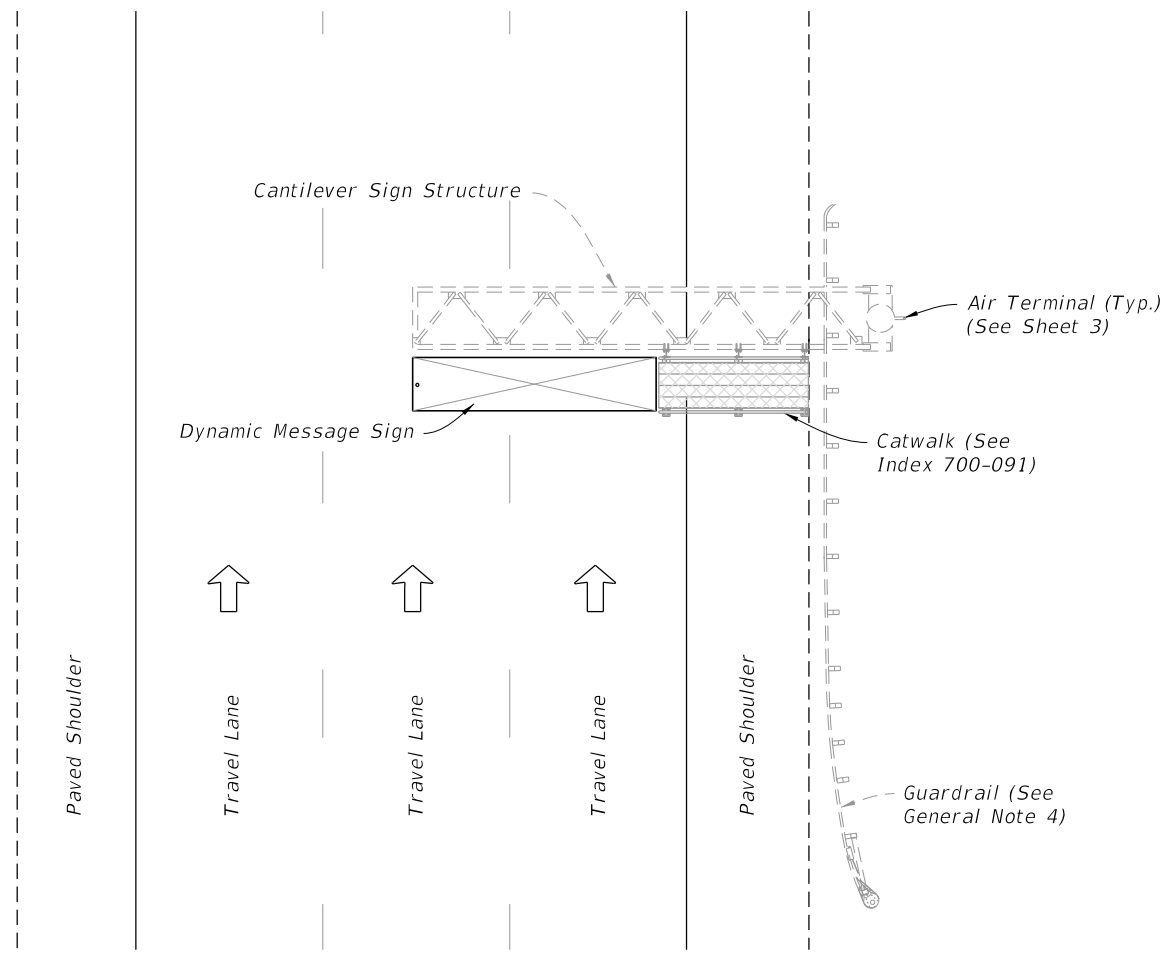

CANTILEVER STRUCTURE PLAN VIEW

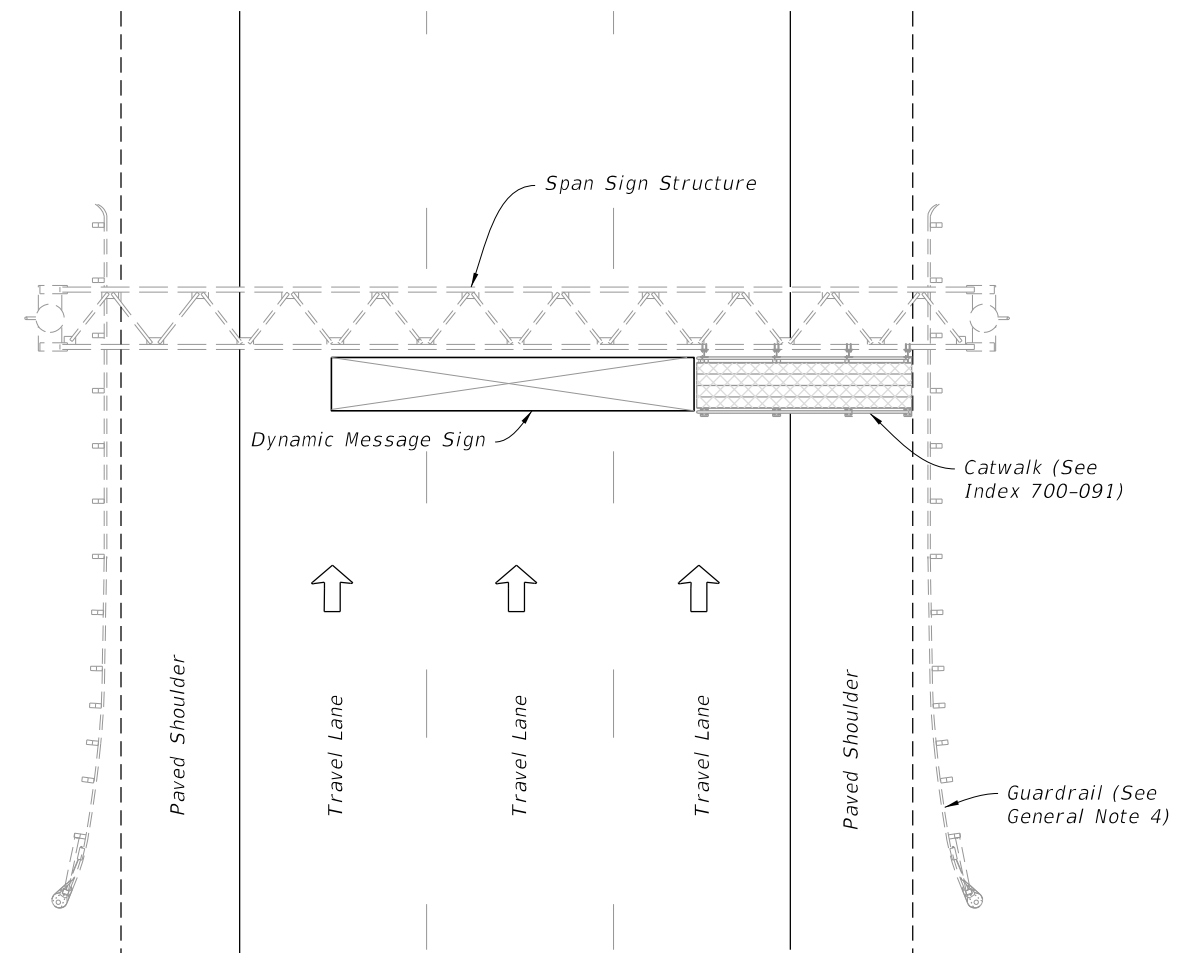

SPAN STRUCTURE PLAN VIEW

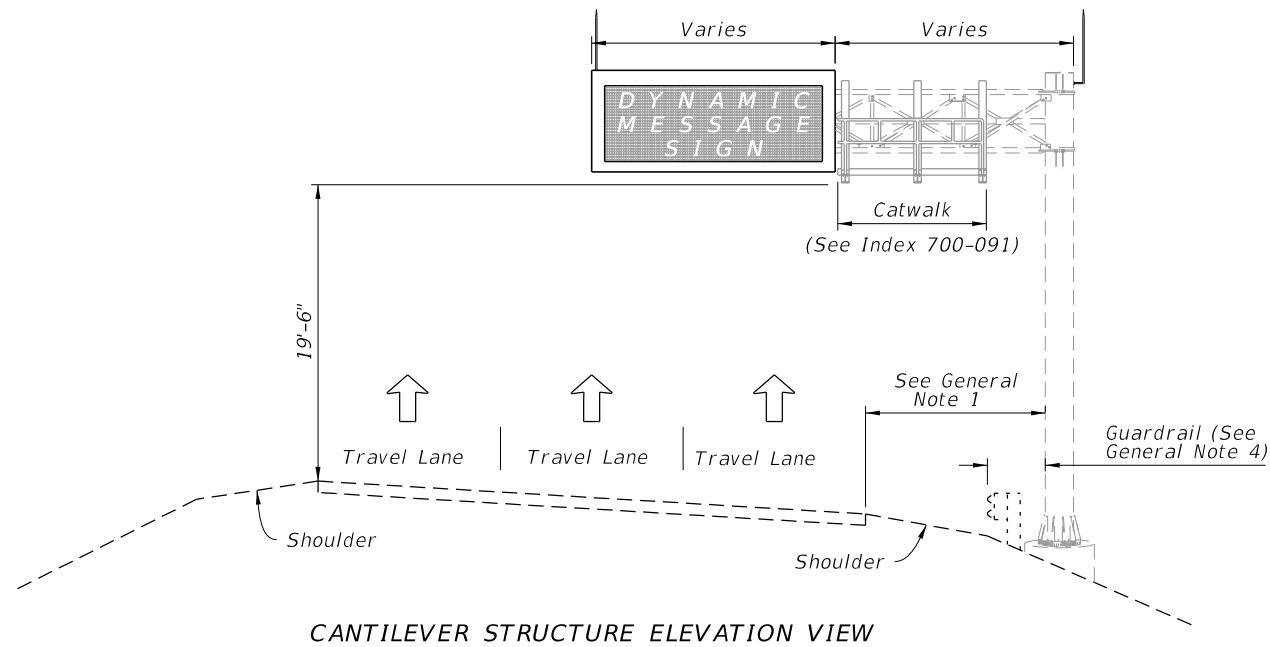

CANTILEVER STRUCTURE ELEVATION VIEW

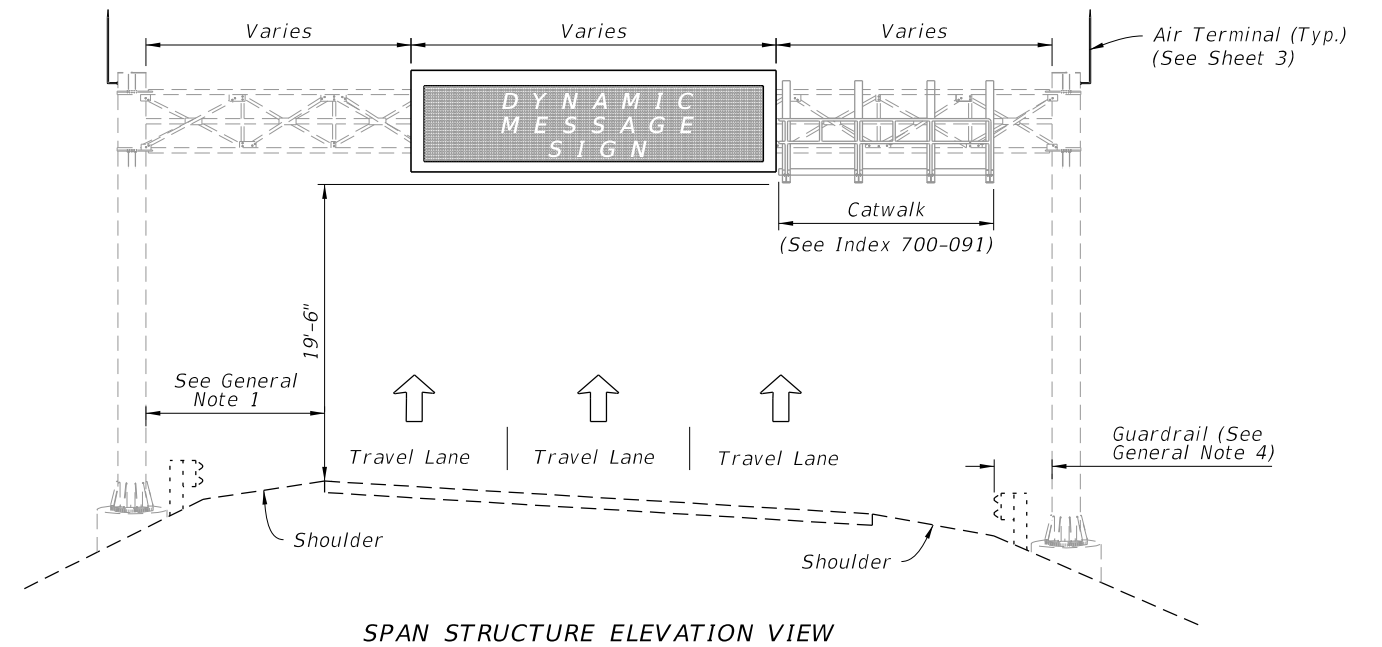

SPAN STRUCTURE ELEVATION VIEW

DYNAMIC MESSAGE SIGN GENERAL LAYOUT

NOTE: Actual number and direction of travel lanes varies.

9/29/2025 7:28:55 AM

LAST REVISION 11/01/19	REVISION	DESCRIPTION:		FY 2026-27 STANDARD PLANS	DYNAMIC MESSAGE SIGN WALK-IN	INDEX 700-090	SHEET 2 of 5
---------------------------	----------	--------------	---	------------------------------	------------------------------	------------------	-----------------

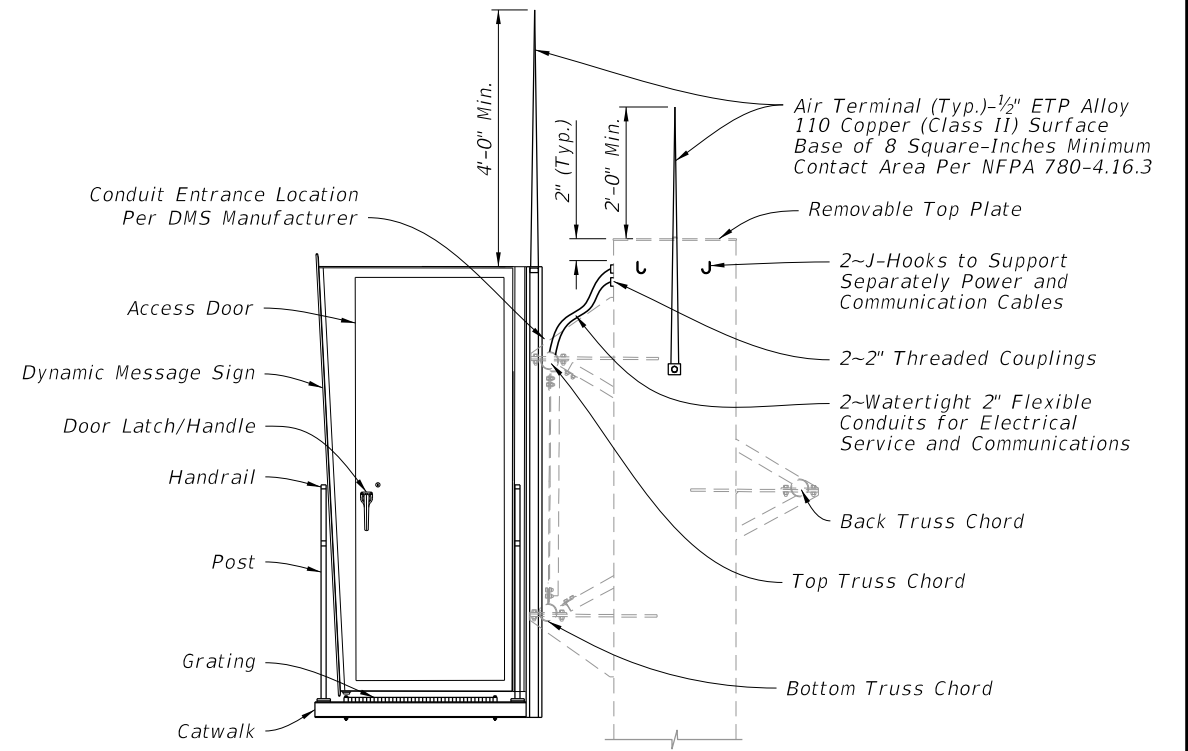
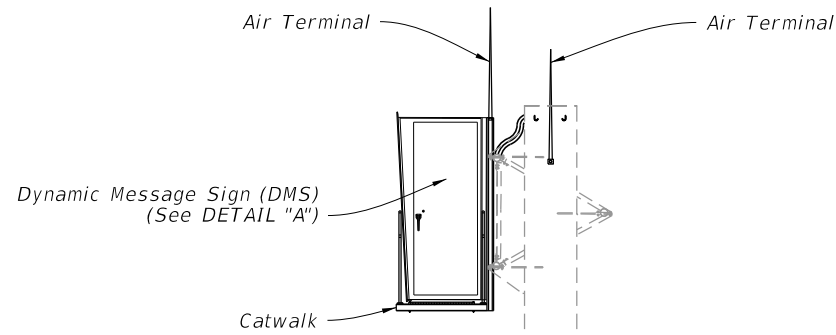

DETAIL "A"

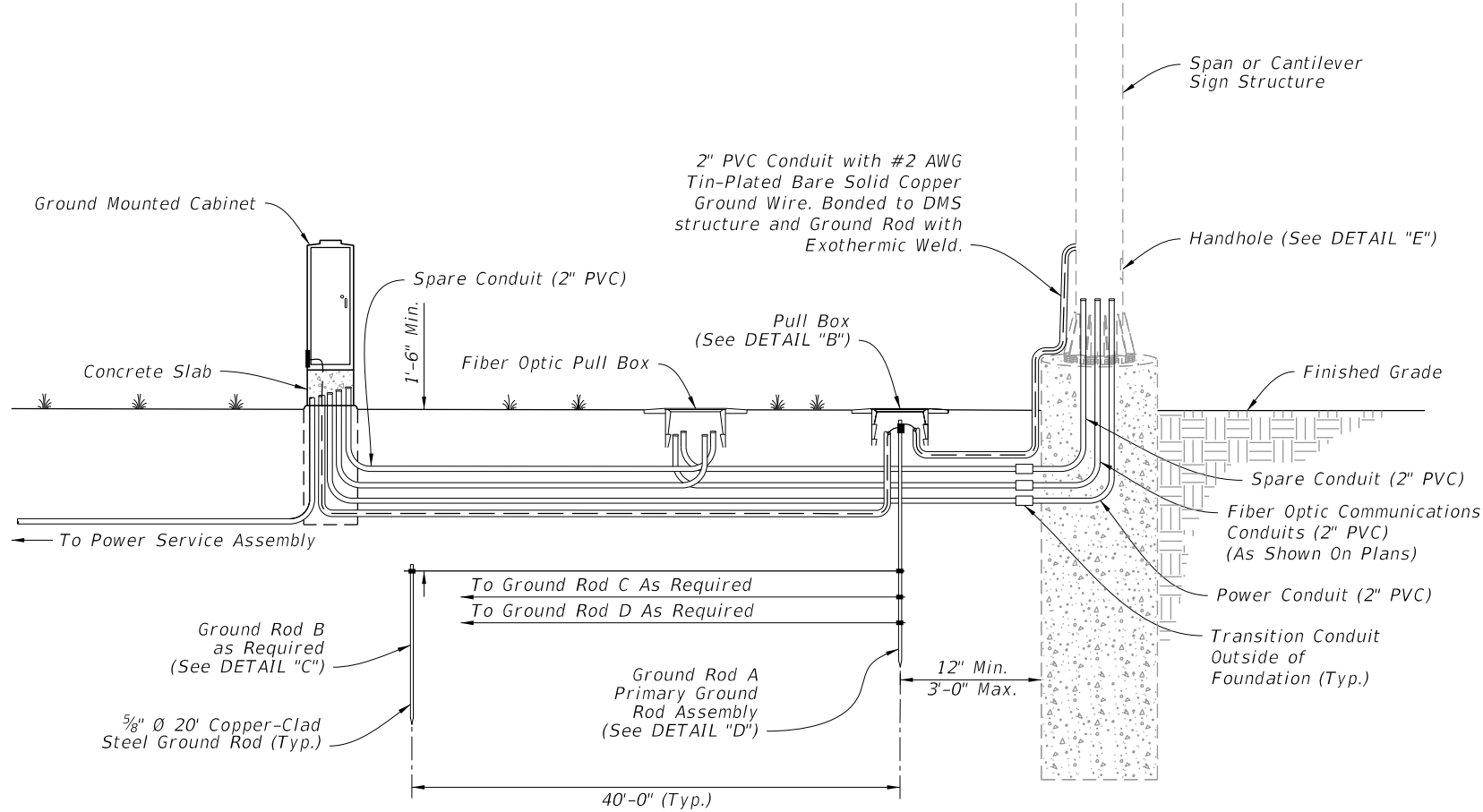

GROUND MOUNTED CABINET

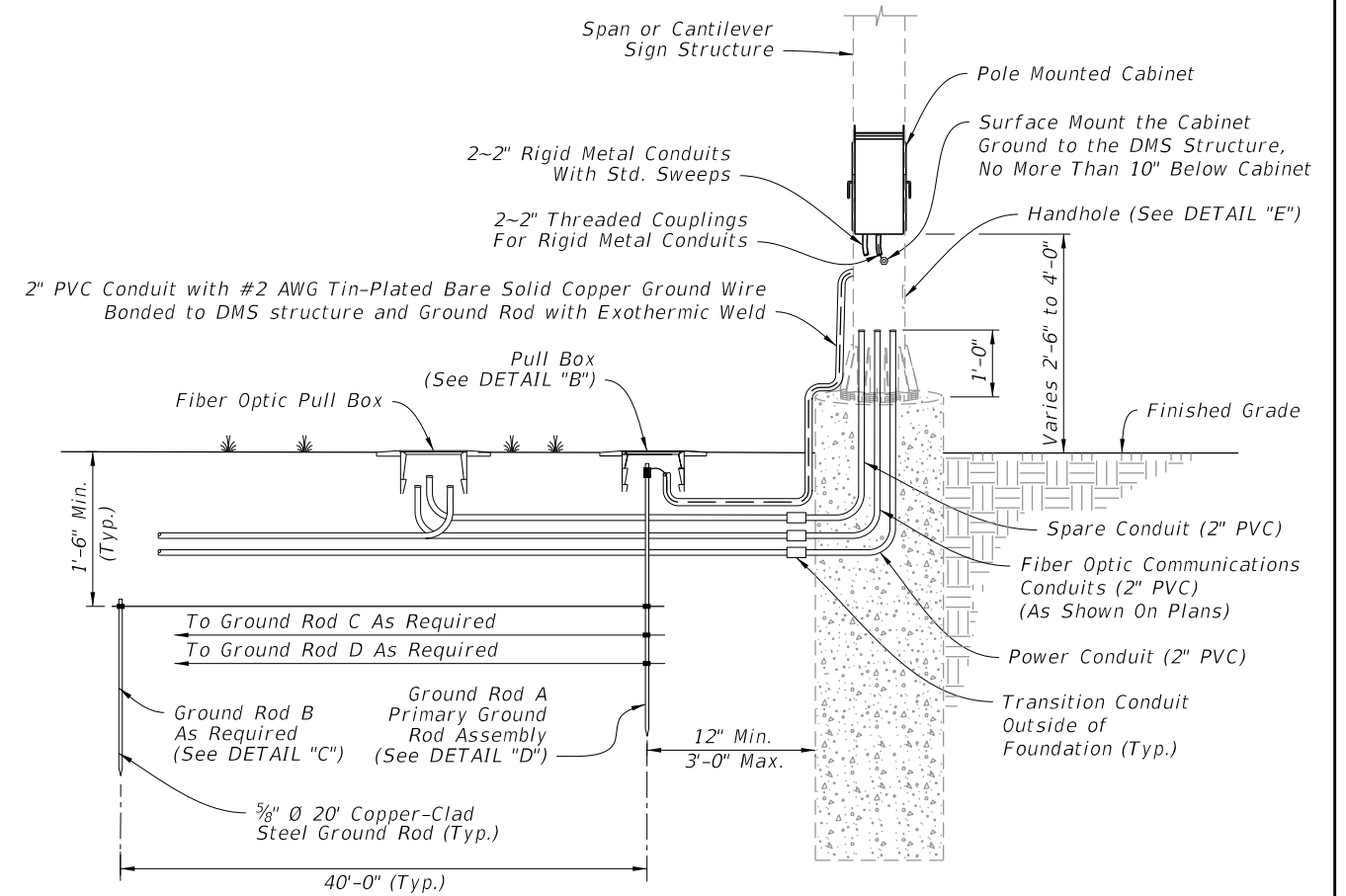

POLE MOUNTED CABINET

DYNAMIC MESSAGE SIGN GROUNDING AND CONDUIT DETAIL

9/29/2025 7:29:03 AM

LAST REVISION 11/01/17	DESCRIPTION:		FY 2026-27 STANDARD PLANS	DYNAMIC MESSAGE SIGN WALK-IN	INDEX	SHEET
					700-090	3 of 5

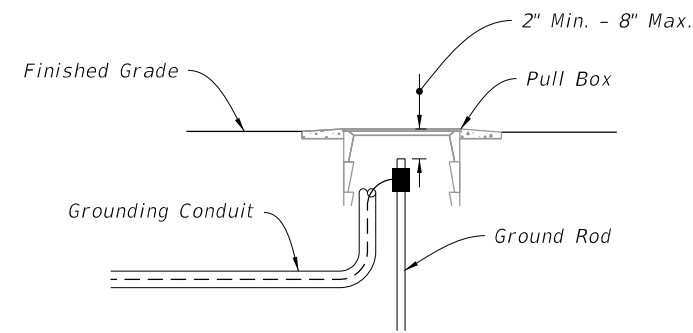

(Pole Mounted Cabinet Configuration Shown)

DETAIL "B"

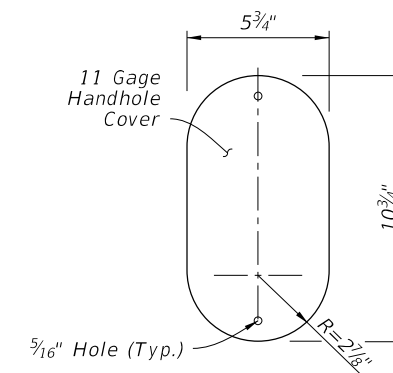

COVER

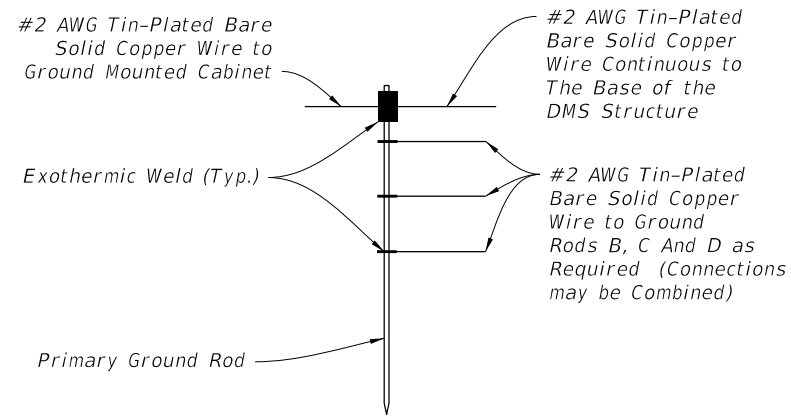

DETAIL "C"

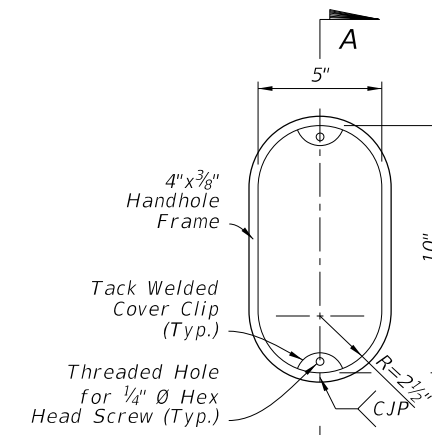

HANDHOLE FRAME

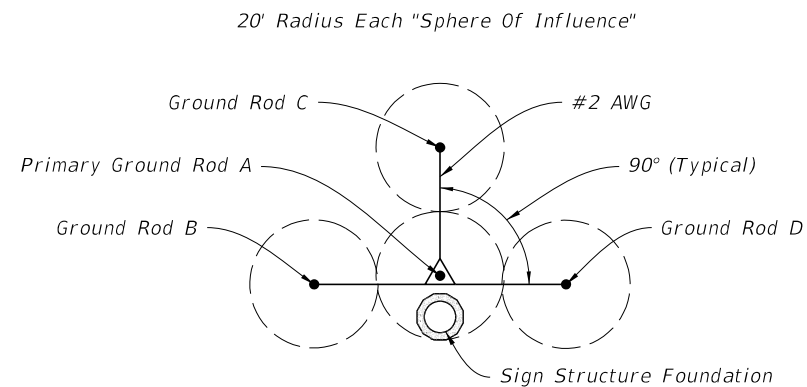

TYPICAL
 (20' Rods, 40' Spacing)

GROUND ROD ARRAY DETAIL

DETAIL "D"

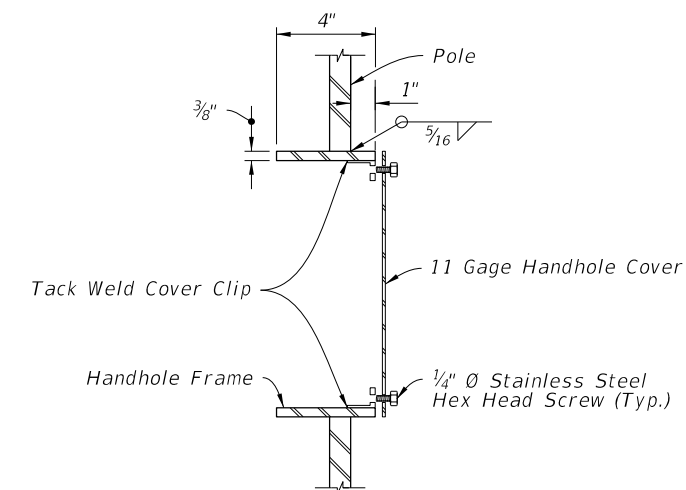

(Thru Handhole)

SECTION A-A

DETAIL "E"

9/29/2025 7:29:11 AM

LAST REVISION 11/01/24	REVISION DESCRIPTION:	 FY 2026-27 STANDARD PLANS	DYNAMIC MESSAGE SIGN WALK-IN	INDEX 700-090	SHEET 4 of 5
---------------------------	--------------------------	--	------------------------------	------------------	-----------------

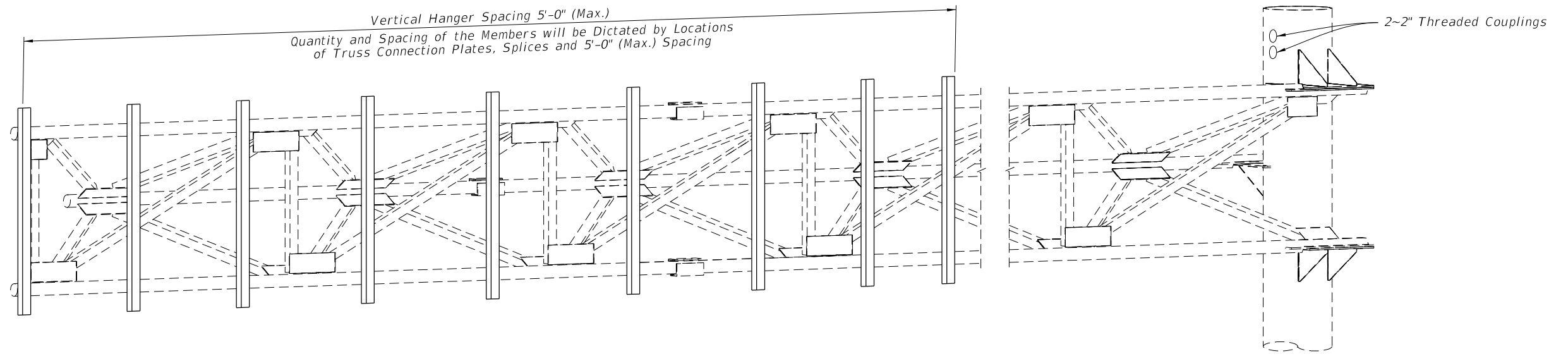

(Cantilever Sign Structure Shown, Span Sign Structure Similar)

HANGER LOCATION DETAIL

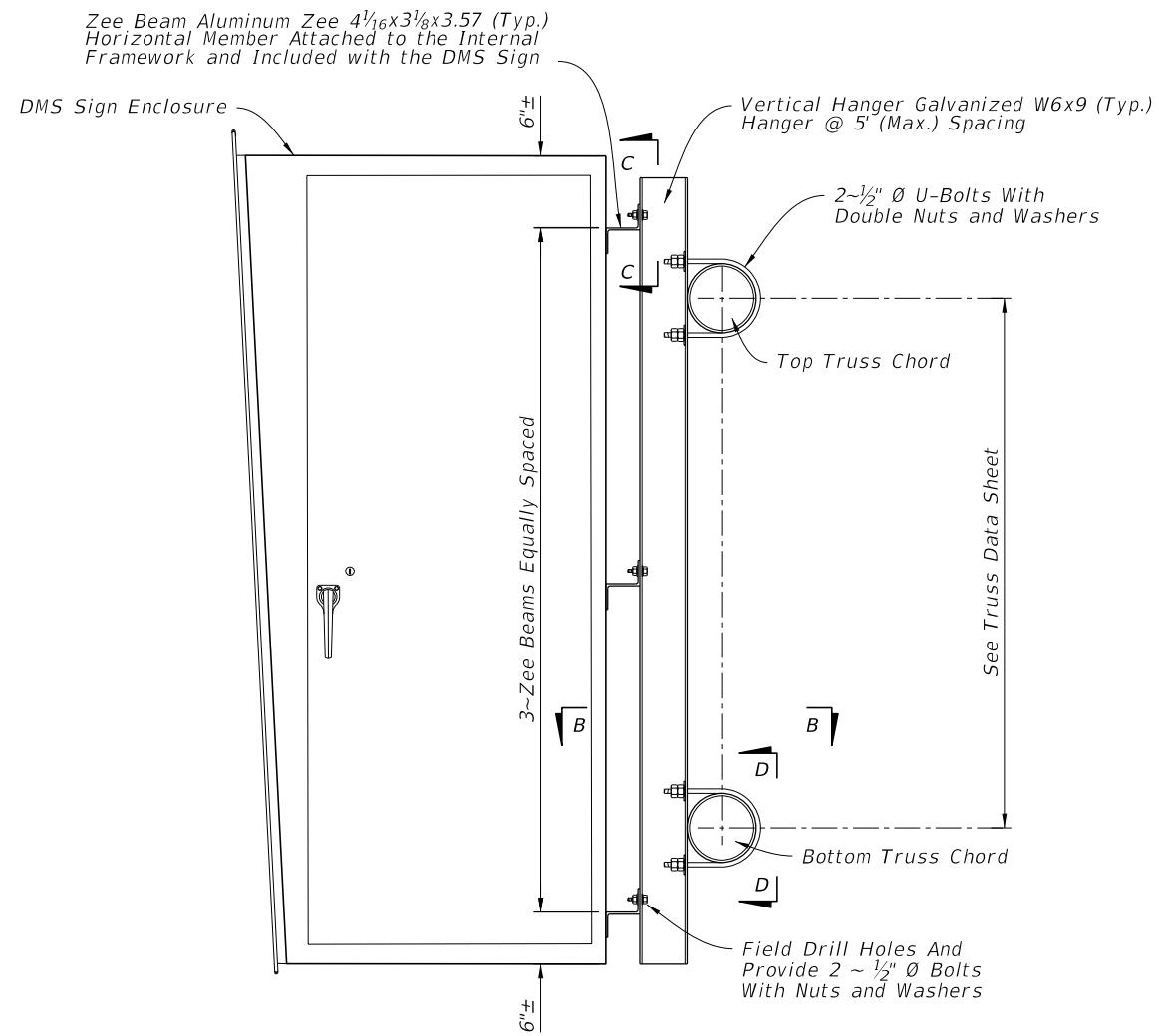

DYNAMIC MESSAGE SIGN END VIEW

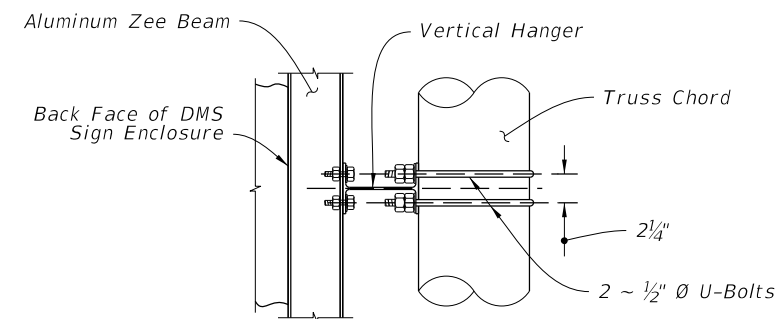

SECTION B-B

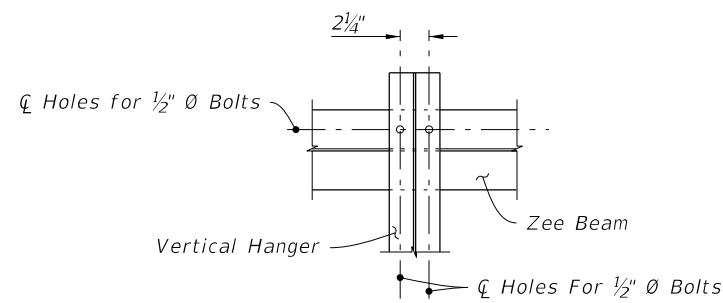

SECTION C-C

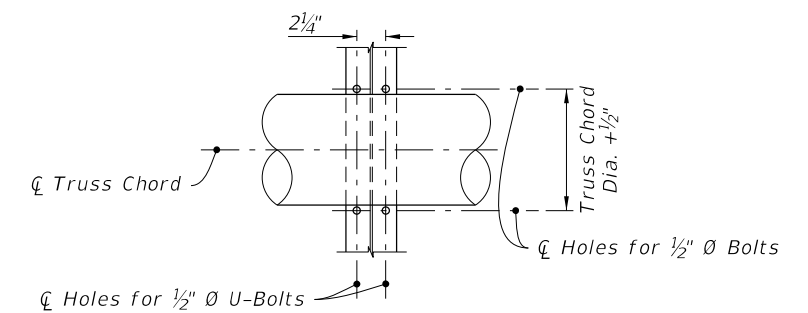

SECTION D-D

9/29/2025 7:29:19 AM

LAST REVISION 11/01/17	REVISION	DESCRIPTION:		FY 2026-27 STANDARD PLANS	DYNAMIC MESSAGE SIGN WALK-IN	INDEX 700-090	SHEET 5 of 5
---------------------------	----------	--------------	---	------------------------------	------------------------------	------------------	-----------------