

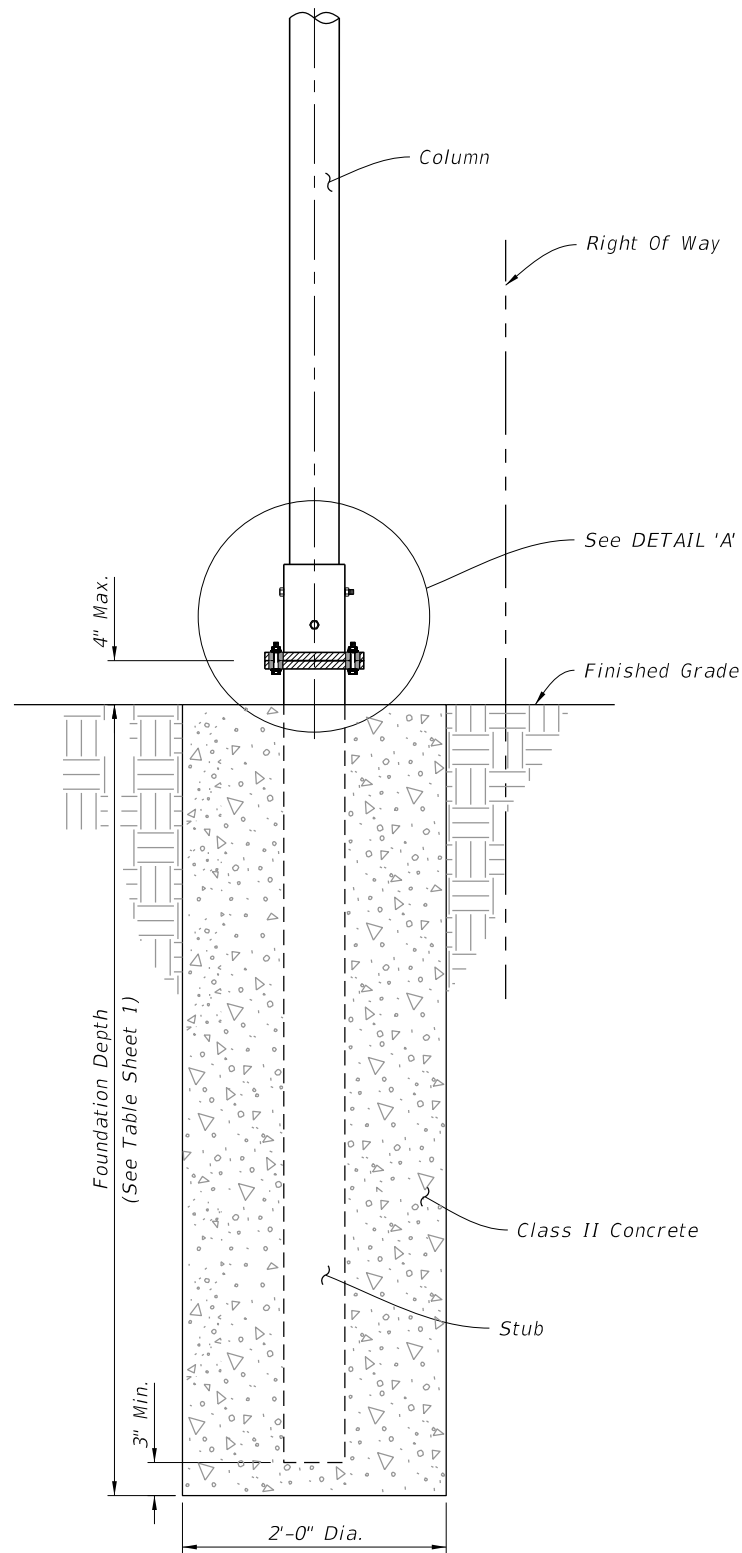

9/29/2025 7:13:47 AM

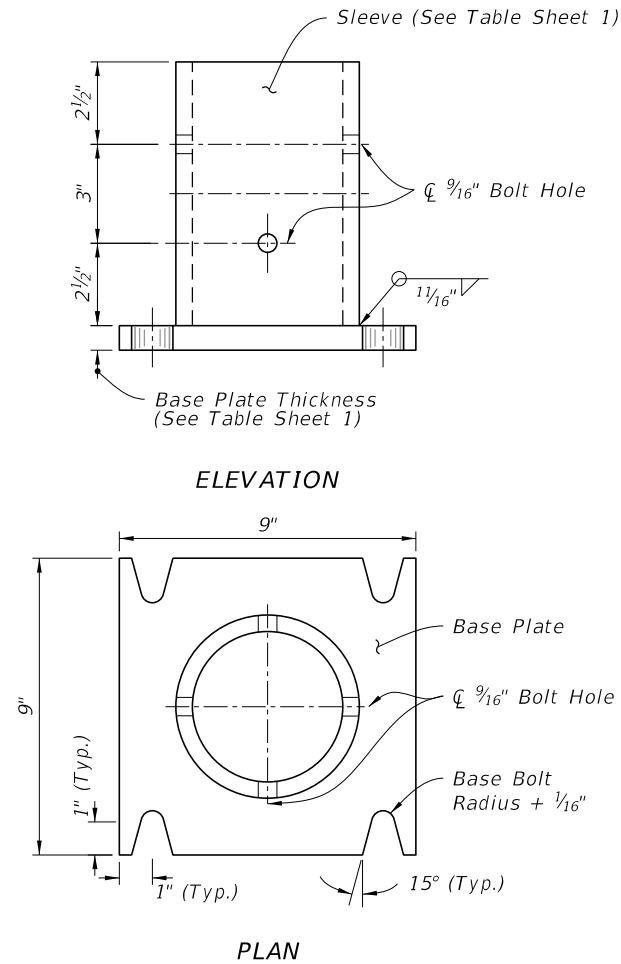

BASE AND FOUNDATION DETAIL



SLEEVE & BASE PLATE DETAILS

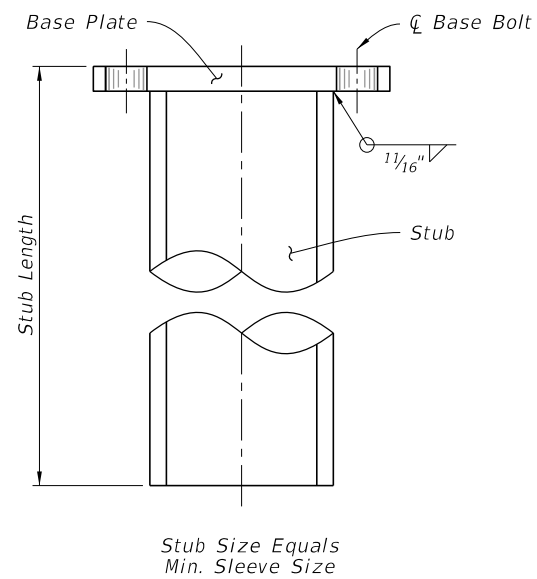

STUB DETAIL

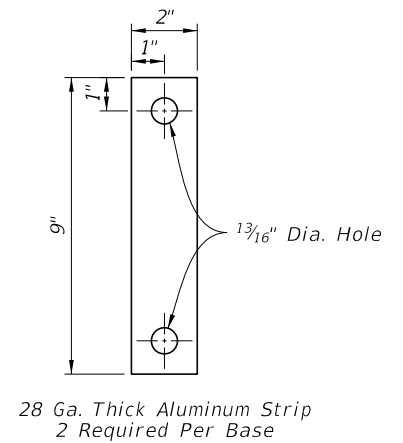

BOLT KEEPER PLATE DETAIL

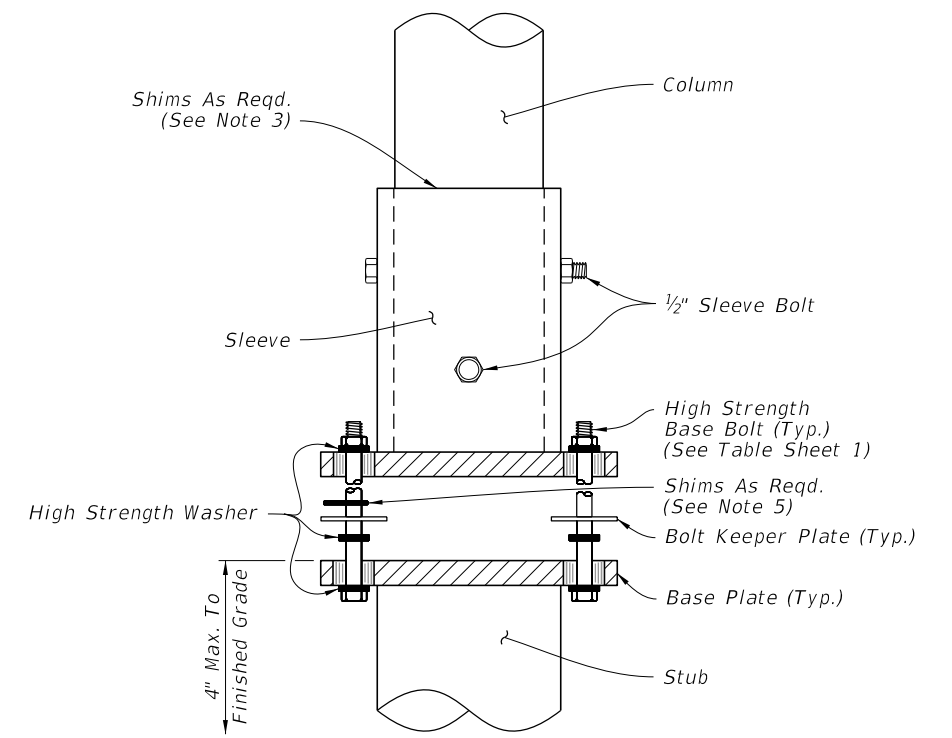

DETAIL 'A'

LAST REVISION 11/01/21

REVISION

DESCRIPTION:



FY 2026-27 STANDARD PLANS

SINGLE COLUMN CANTILEVER GROUND MOUNTED SIGN

INDEX 700-011

SHEET 2 of 2