

NOTES:
 1. A Pull Post Assembly is required at maximum intervals of 500'-0". See Sheet 2.

* Do not anchor fencing to the top of Traffic Railings.

FENCING NOTES

FENCE APPLICATION:
 This bridge fence can only be used on sidewalk installations separated from traffic by a traffic railing.

FENCE INSTALLATION:
 Install posts plumb (within a tolerance of ± 1½"). Use shim plates as required to achieve plumb. The required quantity and thickness of shim plates will be determined in the field. Install chain link fence in accordance with ASTM F567 as applicable.

CONCRETE PARAPET DETAILS:
 See Index 521-820 - Pedestrian/Bicycle Bullet Railing for Concrete Parapet details. Provide fencing in lieu of aluminum bullet railing as shown on Index 521-820.

LIMITS OF FENCING:
 Limits of fencing are from begin of approach slab at Begin Bridge to end of approach slab at End Bridge, unless otherwise shown in the plans.

PAYMENT:
 Payment will be made under Fencing, Type R. Payment includes posts, horizontal and expansion rails, brace bands, rail ends, combination rail ends, boulevard clamps, chain link fabric, ties, tension bars and bands, post and loop caps, base plates, anchor rods, bolts, nuts, washers, shim plates, neoprene pads, miscellaneous fence fittings and hardware and all incidental materials and labor required to complete installation of the fence.

CROSS REFERENCE:
 For Table of Fence Components and Pull Post Assembly Detail see Sheet 2.
 For Table of Post Attachment Components and Detail "A" see Sheet 3.

10/6/2025 3:25:47 PM

LAST REVISION 11/01/23	DESCRIPTION:		FY 2026-27 STANDARD PLANS	BRIDGE FENCING ON PARAPET (CURVED TOP)	INDEX 550-011	SHEET 1 of 3
---------------------------	--------------	--	--------------------------------------	---	-------------------------	------------------------

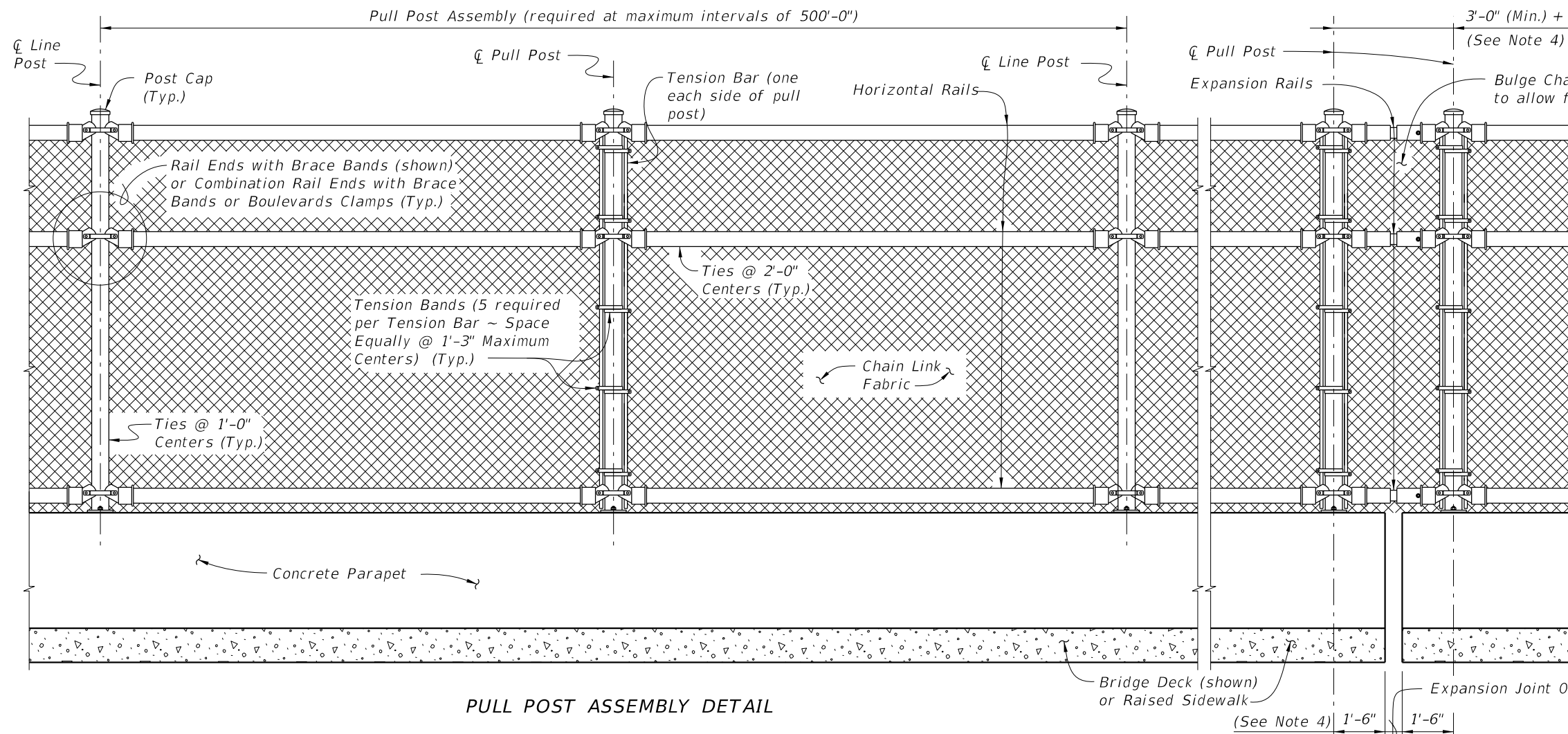

NOTES:

1. For treatment at the bridge ends, see Sheet 1.
2. Expansion Rails are required at expansion joint locations where the total movement exceeds 1". Install expansion rails midway between the fence posts spanning the expansion joint.
3. An Expansion Assembly is required where the total joint movement exceeds 6". Expansion Assembly includes Expansion Rails and two pull posts (as shown). When the Expansion Joint Opening is greater than 9" add an additional length to the free end of the Expansion Rail equal to the difference between the Expansion Joint Opening and 9".
4. Install the post on the fixed (bolted) side of the Expansion Rail 1'-6" from the edge of the expansion joint. Install the post on the slip (unbolted) side of the Expansion Rail 1'-6" from the edge of the expansion joint unless the Expansion Joint Opening is greater than 9". When the Expansion Joint Opening exceeds 9" increase the 1'-6" dimension by the difference between the Expansion Joint Opening and 9".
5. Install nut for the expansion rail finger-tight. The nut will fully engage bolts with a minimum of one bolt thread extending beyond the nuts. Distort the first thread on the outside of the nut to prevent loosening.

PULL POST ASSEMBLY DETAIL

EXPANSION ASSEMBLY DETAIL

(Required only at expansion joint locations where total movement exceeds 6")

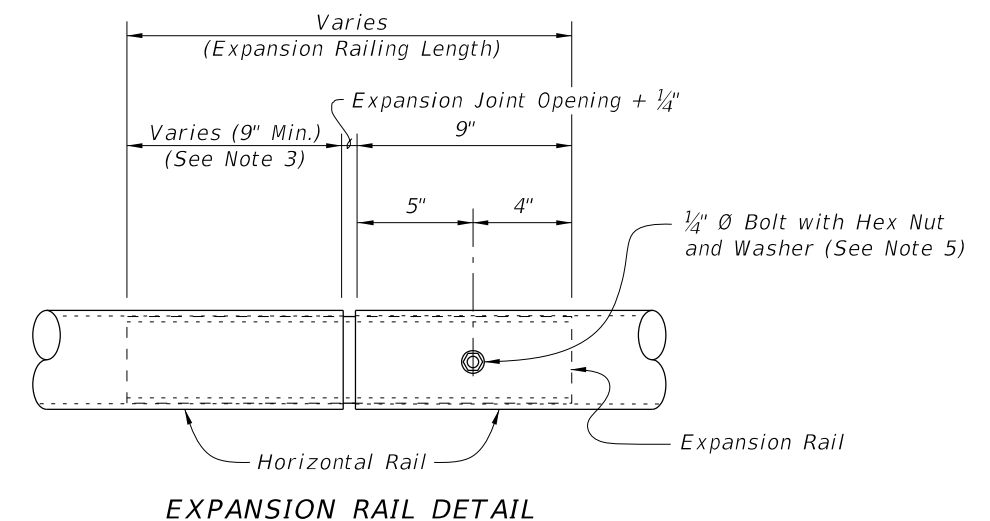

EXPANSION RAIL DETAIL

TABLE OF CHAIN LINK FENCE COMPONENTS

COMPONENT	ASTM DESIGNATION	COMPONENT INFORMATION
Posts	F1083	Galvanized Steel Pipe - 3 1/2" NPS, Schedule 40 Regular Grade
Horizontal Rails	F1083	Galvanized Steel Pipe - 3" NPS, Schedule 40 Regular Grade
Expansion Rails	F1083	Galvanized Steel Pipe - 2 1/2" NPS, Schedule 40 Regular Grade
Bolts	A307	1/4" Ø x 4 1/4" Hex Head Bolts for Expansion Rail Connections
Nuts	A563	Hex Nuts for Expansion Rail Connections
Washers	F436	Flat Washers for Expansion Rail Connections
Chain Link Fabric (2" mesh with twisted top and knuckled bottom selvage)	A392	Zinc Coated Steel - 9 gage (coated wire diameter), Class 2 Coating
	A491	Aluminum Coated Steel - 9 gage (coated wire diameter)
	F668	Polyvinyl Chloride (PVC) Coated Steel - 9 gage Zinc Coated Wire, Class 2b
Tie Wires	F626	Zinc Coated Steel Wire - 9 gage
Brace Bands	F626	12 Gage (Min. thickness) x 3/4" (Min. width) Steel Bands (Beveled or Heavy)
Tension Bars	F626	3/16" (Min. thickness) x 3/4" (Min. width) x Variable Height Steel Bars ~ Height = Post Length along inside Post - 2" Max.
Tension Bands	F626	14 Gage (Min. thickness) x 3/4" (width) Steel Bands
Miscellaneous Fence Components	F626	Zinc Coated Steel ~ (includes post or loop caps, horizontal and brace rail ends, combination rail ends, boulevard clamps and all other miscellaneous fittings and hardware)

LEGEND: NPS = Nominal Pipe Size

10/16/2025 3:25:54 PM

TABLE OF POST ATTACHMENT COMPONENTS		
COMPONENT	ASTM DESIGNATION	COMPONENT INFORMATION
Base Plates	A36 or A709 Grade 36	$\frac{3}{4}$ " Steel R_L
Shim Plates	A36 or A709 Grade 36 or B209 Alloy 6061-T6 or B221 Alloy 6063-T5	Plate thicknesses as required. Holes in shim plates will be $\frac{3}{4}$ " \emptyset . For edge shims match the edge length of the base plate with a min. width of $\frac{3}{4}$ ". Apply adhesive bonding material bed of 1-1/2" (Min.) wide
Adhesive Anchor Rods	F1554 Grade 36	Fully threaded Headless Anchor Rods $\sim \frac{7}{8}$ " \emptyset x $14\frac{1}{2}$ "
C-I-P Anchor Rods	F1554 Grade 36	Hex Head Anchor Rods $\sim \frac{7}{8}$ " \emptyset x $14\frac{1}{2}$ "
Nuts	A563	Hex Nuts for Base Plate Connections
Washers	F436	Flat Washers for Base Plate Connections
Bearing Pads (Plain)	-	In accordance with Specification Section 932 for ancillary structures

POST ATTACHMENT NOTES

ANCHOR RODS, NUTS AND WASHERS:

After the nuts have been tightened, distort the Anchor Rod threads to prevent removal of the nuts. Coat distorted threads and exposed trimmed ends of anchors with a galvanizing compound in accordance with Specification Section 562.

COATINGS:

Hot-dip galvanize all Nuts, Washers, Bolts, C-I-P Anchor Rods, Adhesive Anchors and Fence Framework (Posts, Internal Sleeves, Shim Plates and Base Plates) in accordance with Specification Section 962. Hot-dip galvanize Fence Framework after fabrication.

ADHESIVE-BONDED ANCHORS AND DOWELS:

Adhesive Bonding Material Systems for Anchors and Dowels will comply with Specification Section 937 and be installed in accordance with Specification Section 416. Cutting of reinforcing steel is permitted for drilled hole installation.

WELDING:

All welding will be in accordance with the American Welding Society Structural Welding Code (Steel) ANSI/AWS D1.1 (current edition). Weld metal will be E60XX or E70XX. Nondestructive testing of welds is not required.

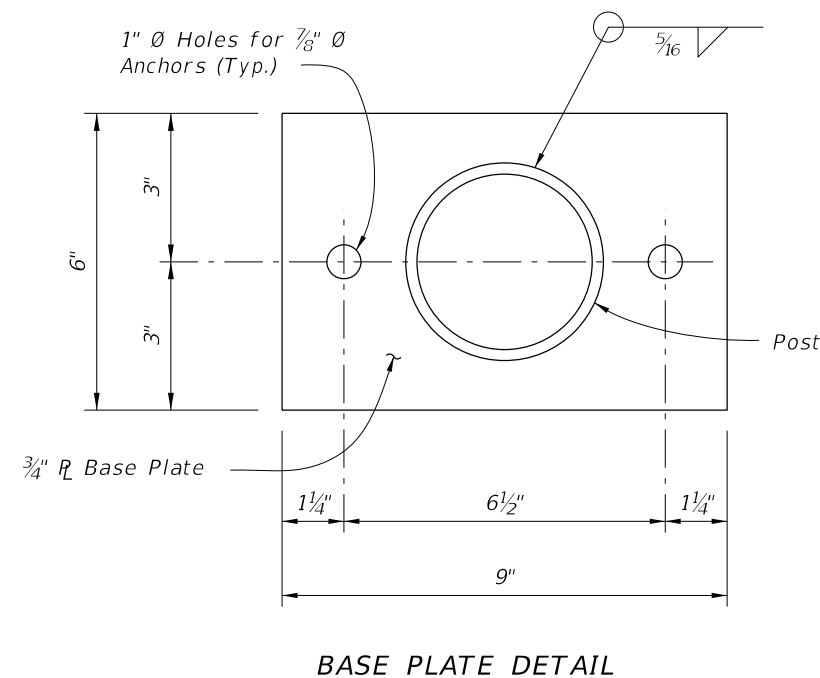
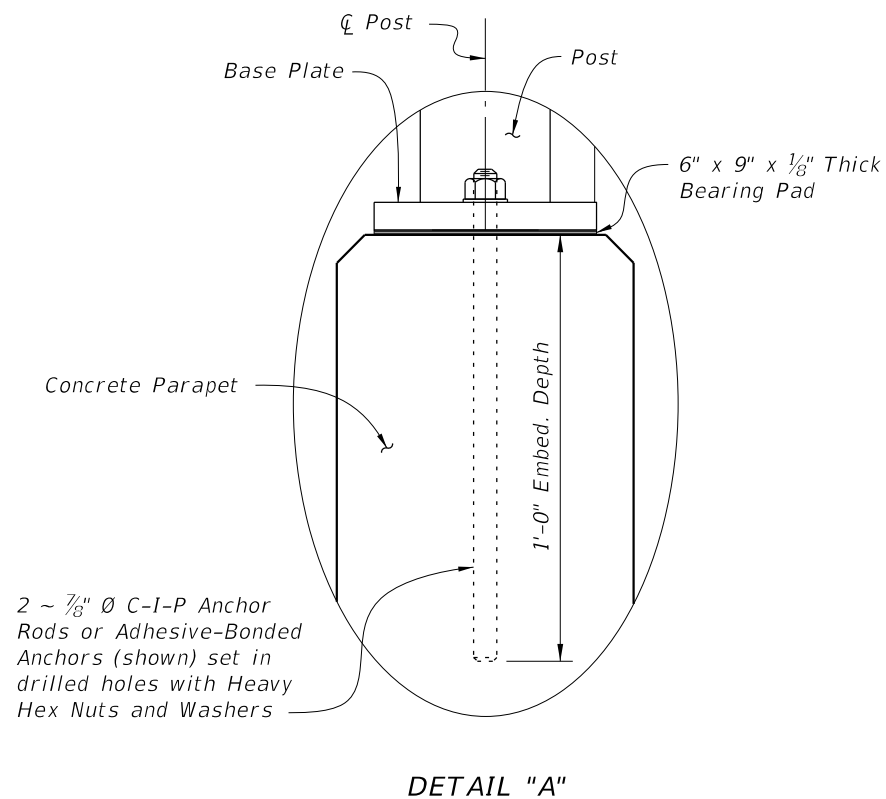

CROSS REFERENCE:

For location of Detail "A" see Sheet 1.

10/16/2025 3:26:00 PM

LAST REVISION 11/01/24	REVISION	DESCRIPTION:	 FY 2026-27 STANDARD PLANS	BRIDGE FENCING ON PARAPET (CURVED TOP)	INDEX 550-011	SHEET 3 of 3
---------------------------	----------	--------------	---	---	-------------------------	------------------------