

3D VIEW OF RAILING WITH TYPE 1 - PICKET INFILL PANEL
(42" Height shown, 48" Height Similar)

TABLE 1 - RAILING MEMBERS

| MEMBER | DESIGNATION | OUTSIDE DIMENSION | WALL THICKNESS |
|---|----------------------|-------------------|----------------|
| Post "A" | HSS 2½ x 1½ x 1/8 | 2.50" x 1.50" | 0.125" |
| Post "B" | HSS 2½ x 1½ x 3/16 | 2.50" x 1.50" | 0.188" |
| Top Rail | 2½" NPS (Sch. 10) | 2.875" | 0.120" |
| | HSS 3.000 x 0.120 | 3.000" | 0.120" |
| End Hoops | 2½" NPS (Sch. 10) | 2.875" | 0.120" |
| | HSS 3.000 x 0.120 | 3.000" | 0.120" |
| Top Rail Joint/Splice Sleeves | HSS 2.500 x 0.125 | 2.500" | 0.125" |
| Intermediate & Bottom Rail | HSS 2 x 2 x 3/16 | 2.00" x 2.00" | 0.188" (1) |
| Int. & Bottom Rail Post Connection Sleeve | HSS 1.500 x 0.125 | 1.500" | 0.125" (1) |
| Handrail Joint/Splice Sleeves | 1" NPS (Sch. 40) | 1.315" | 0.133" |
| | HSS 1.500 x 0.125 | 1.500" | 0.125" |
| Handrails | 1½" NPS (Sch. 40) | 1.900" | 0.145" |
| Handrail Support Bar | ¾" Ø Round Bar | 0.750" | N/A |
| Pickets (Type 1 Infill Panel) | ¾" Ø Round Bar | 0.750" | N/A |
| Infill Panel Members (Types 2 - 5) | Varies (See Details) | Varies | Varies |

TABLE 1 NOTES:

(1) 0.125" wall thickness permitted for rails with post spacings less than 5'-8", except that Post Connection Sleeve must be 1¼" NPS (Sch. 40).

NOTES

Notes:

- Shop Drawings are required; see Specification Section 515
- For bridge mounted railings work this Index with Index 515-051 Bridge Bicycle/Pedestrian Railing
- Materials:
 - Pipe Rails and Pickets: ASTM A500 Grade B, C or D, or ASTM A53 Grade B for standard weight pipe (Schedule 40) and ASTM A36 for bars.
 - Structural Tube: ASTM A500 Grade A, B, C, or D or ASTM A501
 - Steel Plate: ASTM A36 or ASTM A709 Grade 36
 - U-Channels and filler plates: ASTM A36 or ASTM A1011 (Grade 36).
 - Stainless steel (SS) screws: Type 316 or 18-8 Alloy
 - Galvanized Steel Fasteners: coated in accordance with Specification Section 962.
 - Hex Head Bolts: ASTM A 307
 - 7/8" diameter single bolt option, Grade 36
 - 7/16" four bolt option, Grade 55
 - Adhesive Anchors: ASTM F1554 fully threaded rods, Grade 55
 - Hex Nuts: ASTM A563
 - Flat Washers: ASTM F436
 - Plate Washers: ASTM A36 or ASTM A706 Grade 36.
 - Shims: ASTM B209 Alloy 6061
 - Bearing Pads: 1/8" Plain, Fabric Reinforced or Fabric Laminated pads that meet the requirements of Specification Section 932 for Ancillary Structures.
- Fabricate pickets and vertical panel elements parallel to the posts; except Type 2, 3 and 5 panel infills may be fabricated parallel to the longitudinal grade. Maintain a maximum clear opening of 5/8" for standard installations and 3/8" when a 4" sphere requirement is indicated in the Data Tables.
- Maximum spacing between expansion joints is 40'-0". Locate an Expansion Joint between the posts on either side of the Deck Expansion Joint.
- Field splices are similar to the Expansion Joint Detail and may be approved by the Engineer to facilitate handling; but the top rail must be continuous across a minimum of two posts.
- For intermediate and bottom horizontal rails, the screwed joints shown may be substituted with alternate joints shown in detail "K".
- Make corners and changes in tangential longitudinal alignment with a 9" bend radius or terminate adjoining sections with mitered end sections when handrails are not required.
- For changes in tangential longitudinal alignment greater than 45°, position posts a maximum of 2'-0" each side of the corner but not at the corner apex.
- For curved longitudinal alignments, shop bend the top and bottom rails and handrails to match the alignment radius.
- Handrails are required and must be continuous at landings for:
 - Grades Steeper than 5%.
 - Three or more steps
- Installation: Cutting of reinforcing steel is permitted for post installed anchors.

9/26/2025 1:17:45 PM

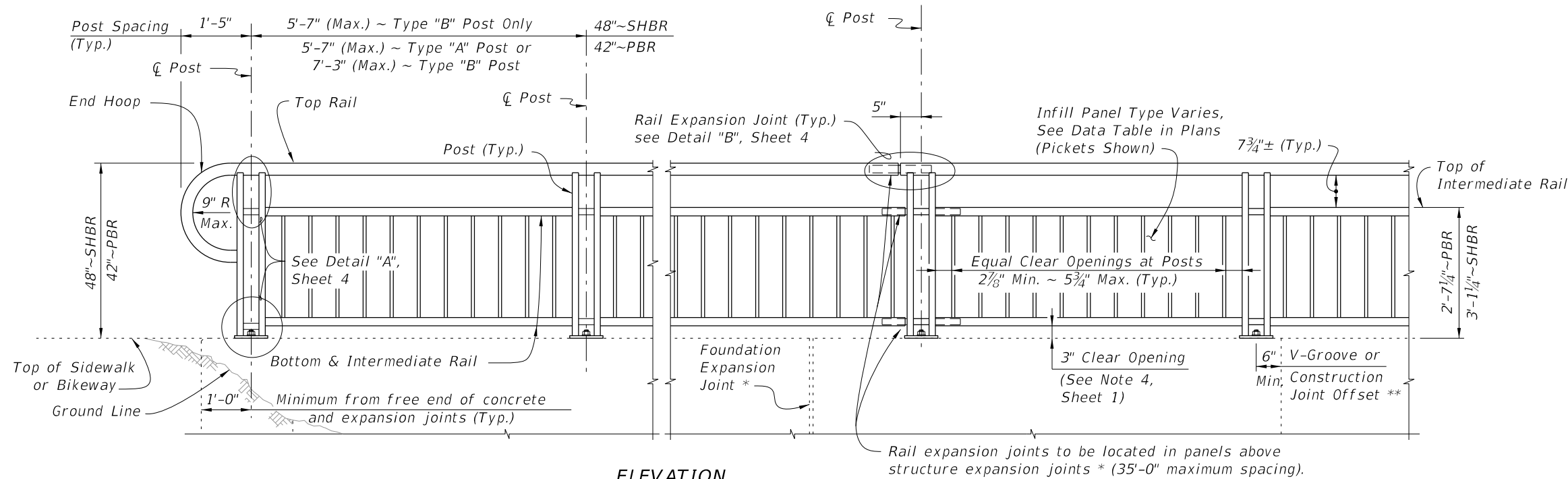

ELEVATION
(Showing Outside Face of Railing with Type "A" Posts)

TYPICAL RAILING DETAILS & RAILINGS ON GRADES 0% TO 5%
(Type 1 - Picket Railing Shown, Other Types Similar)

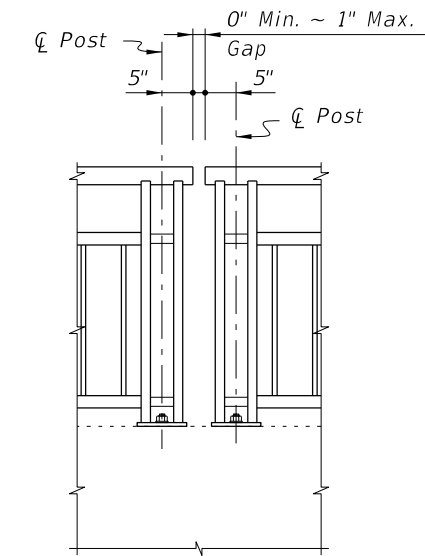

Note: Non-continuous corners are permitted when handrails are not required.

EXPANDED ELEVATION AT CORNERS
DETAIL FOR NON-CONTINUOUS RAILING AT CORNERS

- NOTES:**
- * Keyed construction joints in Index 400-011 Gravity Wall are not considered to be expansion joints.
 - ** Contraction joints (Tooled or Saw Cut) in sidewalks do not require a 6" minimum offset.

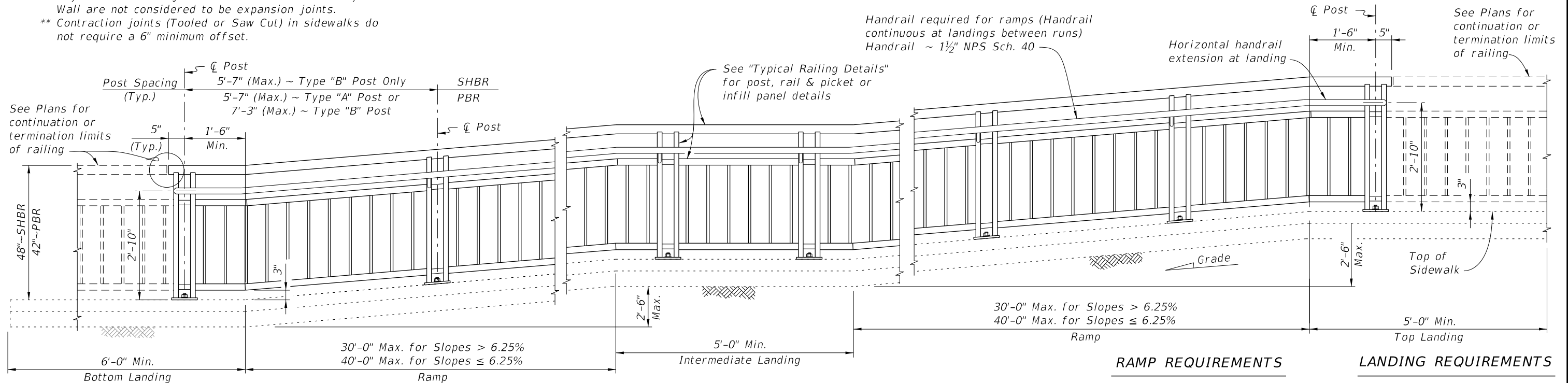

ELEVATION
(Showing Inside Face of Railing with Type "A" Posts)

RAILINGS ON GRADES STEEPER THAN 5%
(Type 1 - Picket Railing Shown, Other Types Similar)

RAMP REQUIREMENTS
For slopes greater than 5%:
Max. ramp slope = 8.33%
Max. ramp cross-slope = 2.0%

LANDING REQUIREMENTS
Max. landing slope = 2%
Max. landing cross-slope = 2%

9/26/2025 1:17:52 PM

| | | | | | | |
|---------------------------|--------------|--|------------------------------|------------------------------------|------------------|-----------------|
| LAST REVISION 11/01/16 | DESCRIPTION: | | FY 2026-27 STANDARD PLANS | PEDESTRIAN/BICYCLE RAILING (STEEL) | INDEX 515-052 | SHEET 2 of 8 |
|---------------------------|--------------|--|------------------------------|------------------------------------|------------------|-----------------|

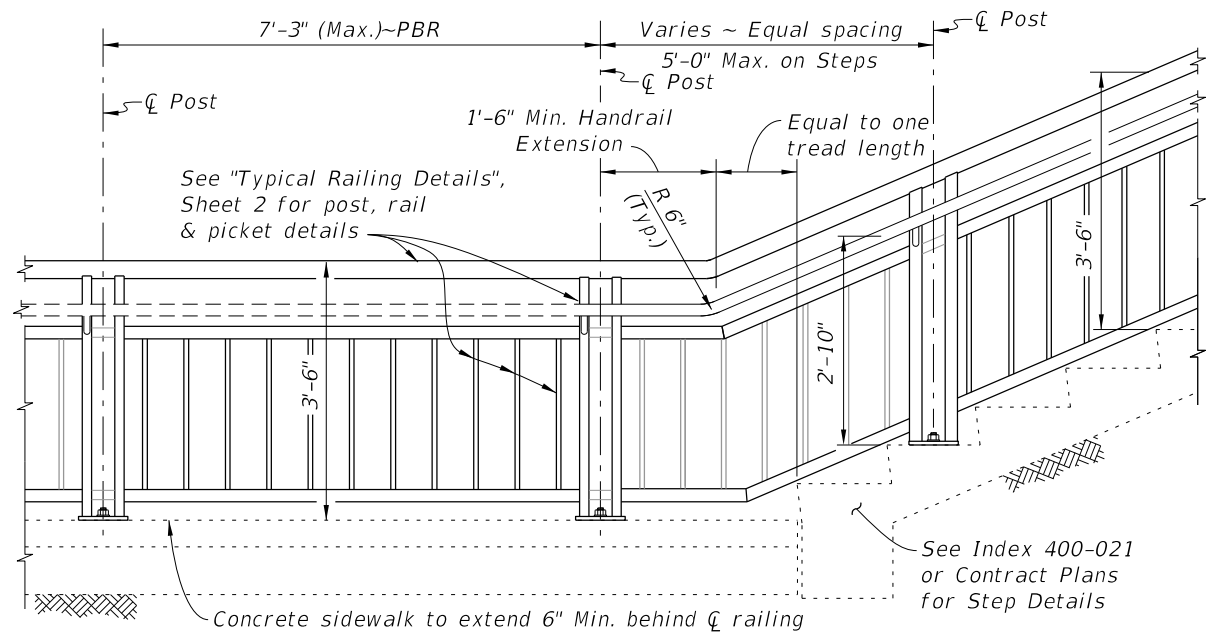

RAILING CONTINUATION BEYOND STEPS OR STAIRS
(Bottom shown, Top similar)

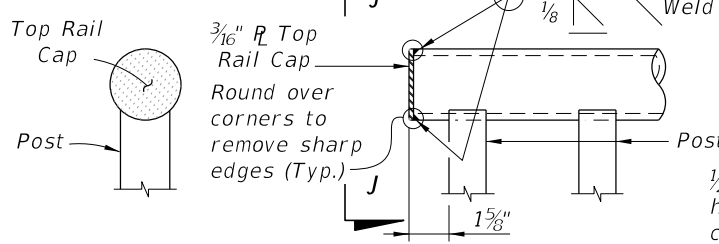

VIEW J-J DETAIL "J" - ELEVATION VIEW TOP RAIL TERMINATION

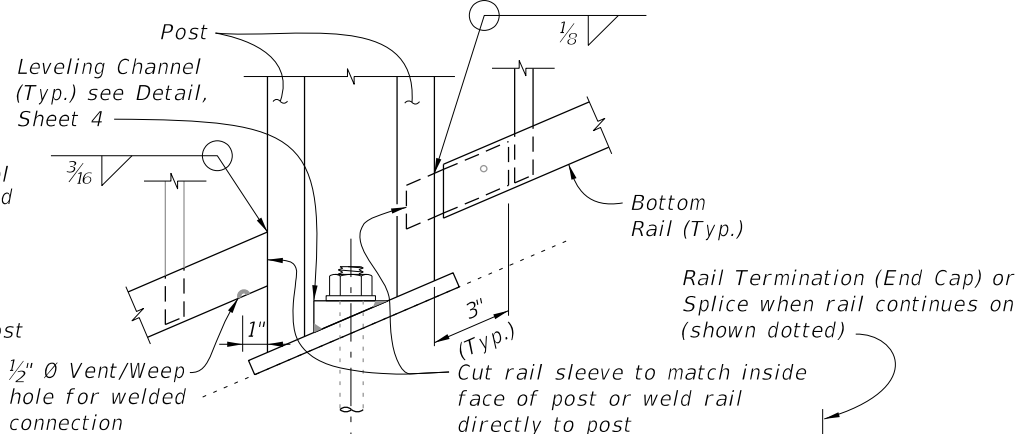

DETAIL "K" - ELEVATION VIEW BOTTOM RAIL CONNECTION (Intermediate Rail Similar)

RAIL TERMINATION DETAILS

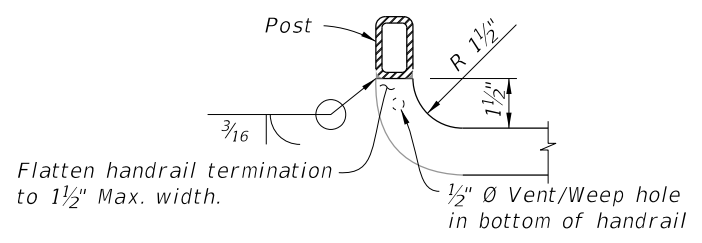

DETAIL "L" - PLAN VIEW HANDRAIL TERMINATION

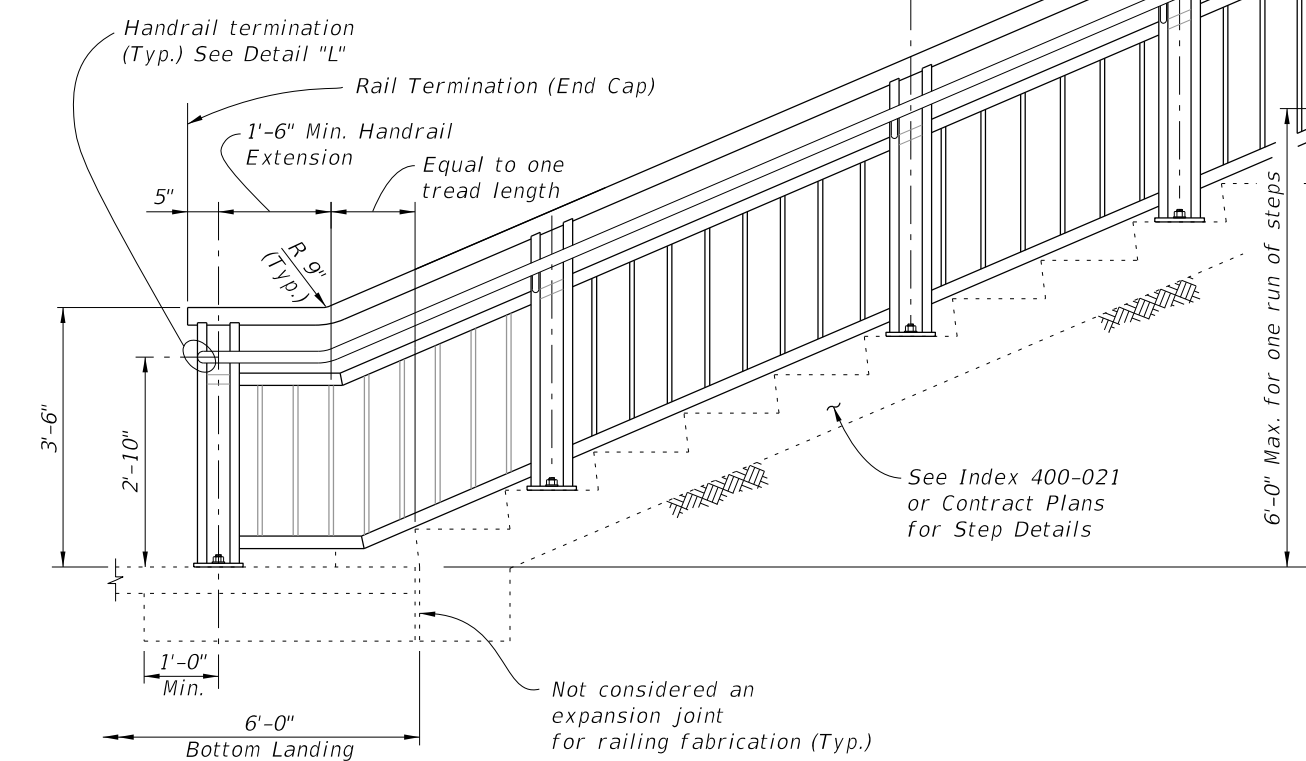

ELEVATION (At-Grade Steps shown, Elevated Stairs similar)

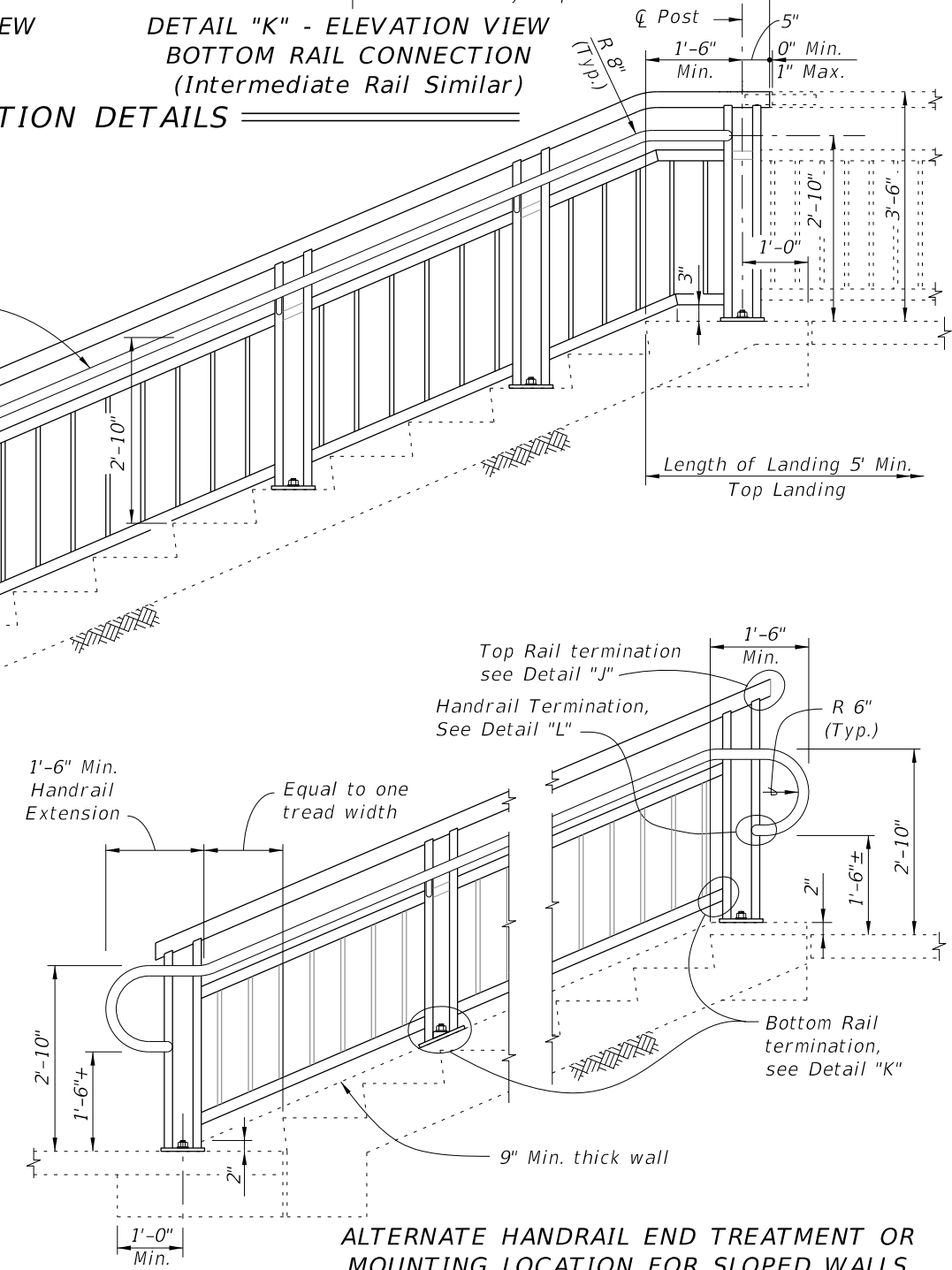

ALTERNATE HANDRAIL END TREATMENT OR MOUNTING LOCATION FOR SLOPED WALLS

RAILINGS ON STEPS & STAIRS

9/26/2025 1:17:58 PM

| | | | | | |
|---------------------------|--------------|--|------------------------------------|------------------|-----------------|
| LAST REVISION 11/01/16 | DESCRIPTION: |  FY 2026-27 STANDARD PLANS | PEDESTRIAN/BICYCLE RAILING (STEEL) | INDEX 515-052 | SHEET 3 of 8 |
|---------------------------|--------------|--|------------------------------------|------------------|-----------------|

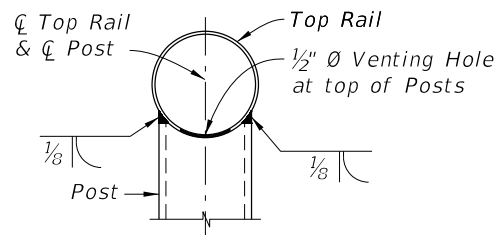

SECTION A-A
(Top Rail Connection)

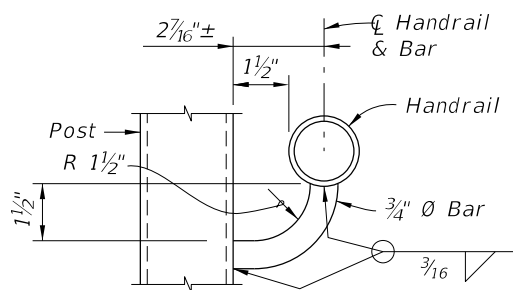

SECTION B-B
(Handrail Connection)

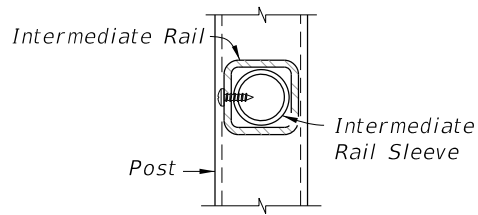

SECTION C-C
(Intermediate Rail Connection)

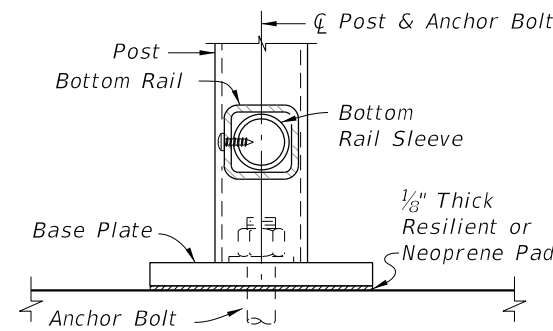

SECTION D-D
(Bottom Rail Connection -
Single Anchor Bolt Shown)

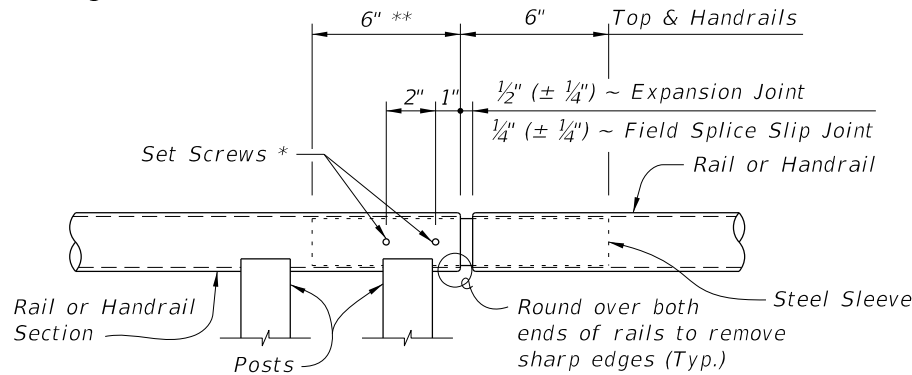

ROUND RAILS - TOP RAIL OR HANDRAIL
(Top Rail at Expansion Joint Shown)

DETAIL "B" - EXPANSION JOINT (FIELD SPLICE SLIP JOINT SIMILAR)

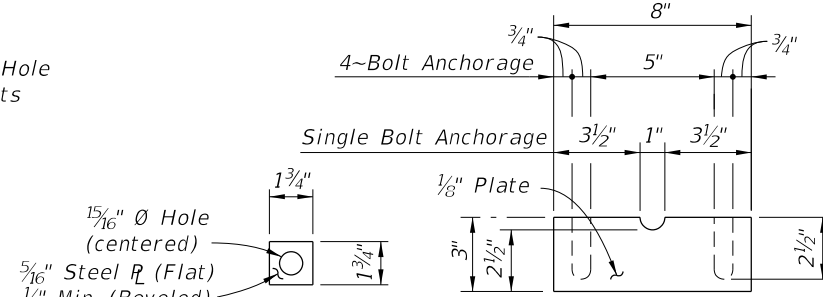

SHIM PLATE DETAIL

PLATE WASHER DETAIL

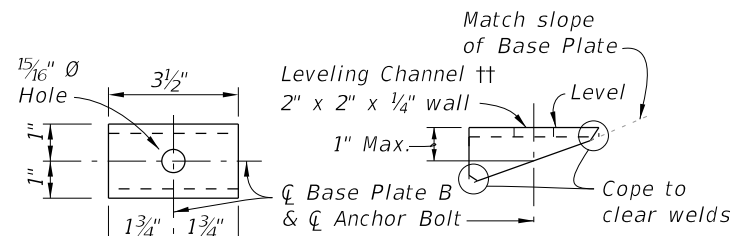

TOP VIEW

SIDE VIEW

LEVELING CHANNEL DETAIL

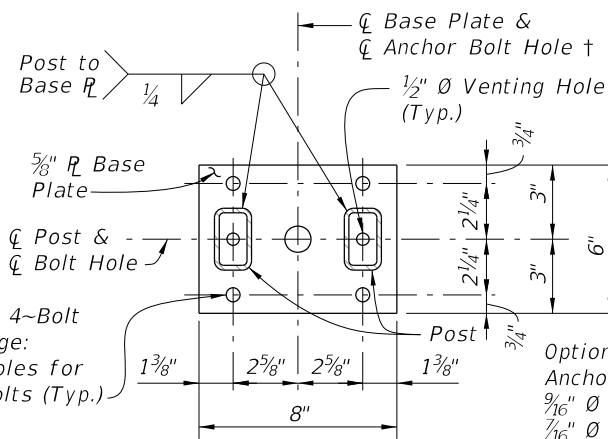

BASE PLATE A

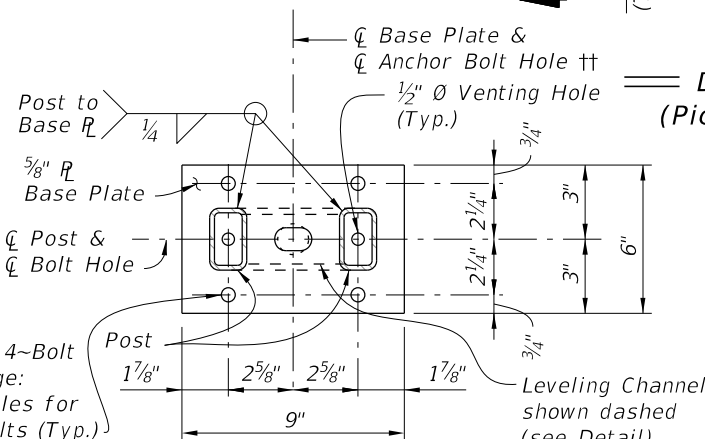

BASE PLATE B

SECTION G-G - BASE PLATE DETAILS

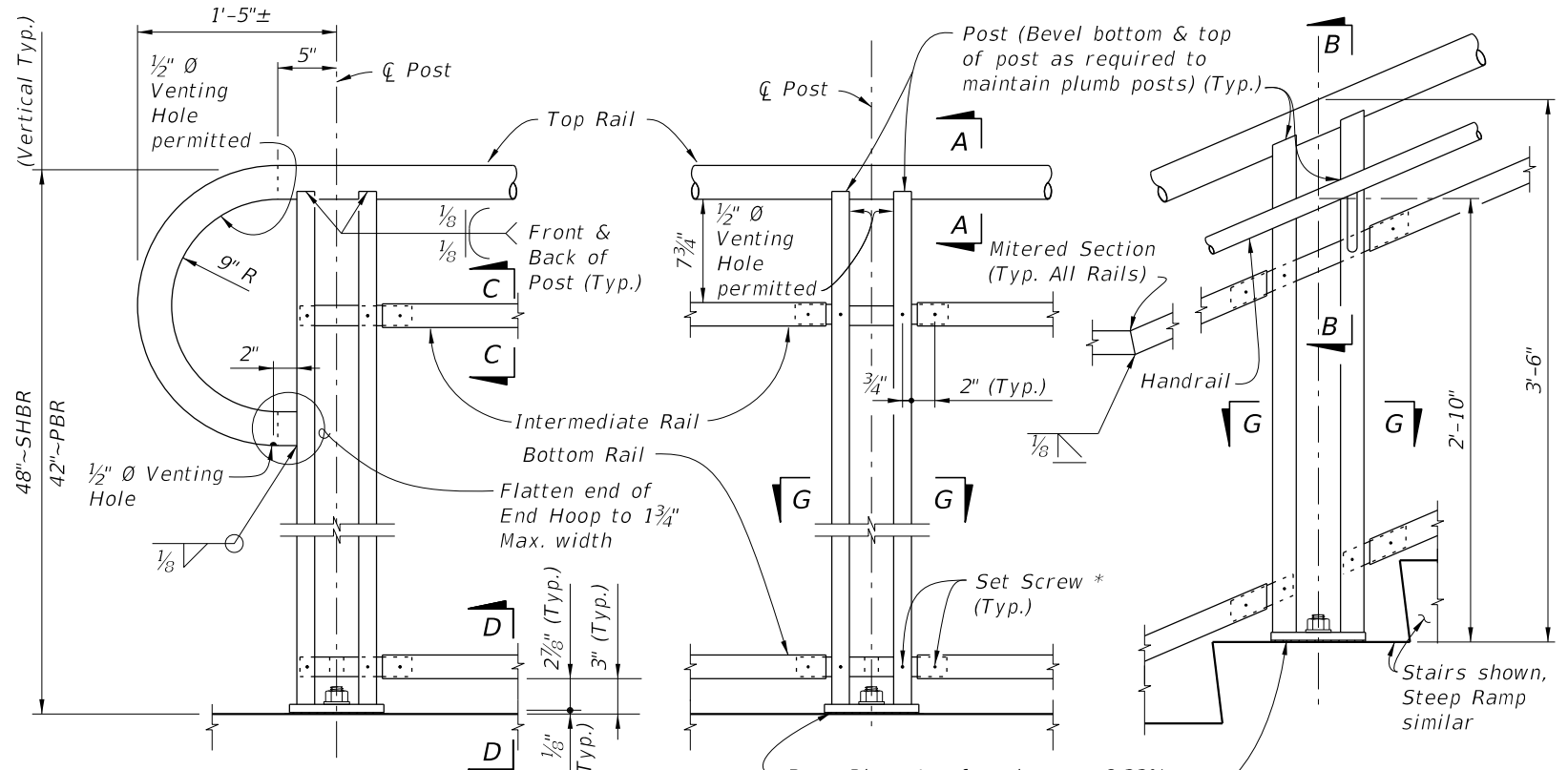

DETAIL "A" - RAIL CONNECTIONS
(Pickets/Panels and 4-Bolt Anchorage
Not Shown for Clarity)

NOTES:

- † Base Plate A (Ramps - Bolts normal) use 1 1/16 inch diameter holes for single anchor bolts with flat washers for slopes ≤ 8.33%.
- ‡ Base Plate B (Stairs - Bolts plumb) use 1 1/4 inch diameter holes for single anchor bolts with beveled plate and washers for slopes > 8.33% to ≤ 15%; use 1 5/16 inch x 1 1/2 inch slotted holes with leveling channel for slopes > 15%.
- * 1/4 inch x 3/4 inch Pan Head Stainless Steel (Type 316 or 18-8 Alloy) Set Screws. Screws must be set flush against the outside face of rails & posts and underside of handrails. 1/2 inch diameter plug welds may be substituted for the set screws. Do not provide set screws for rails at free end of expansion joints.
- ** Embedded length may be 4 inches for plug welded connection.

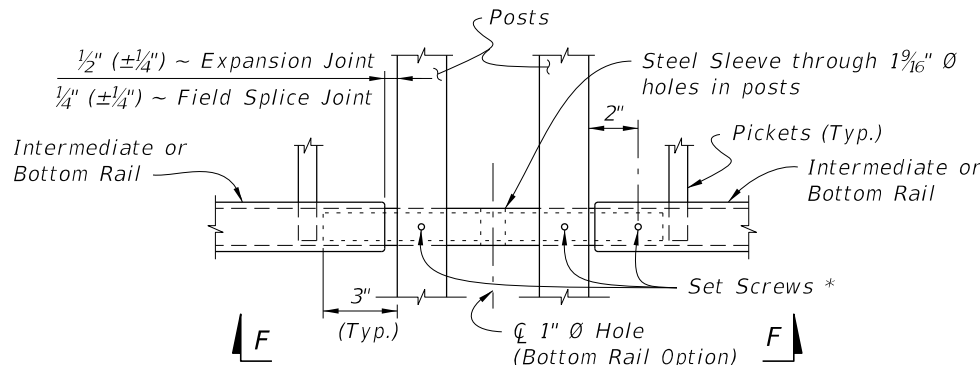

SQUARE RAILS - INTERMEDIATE OR BOTTOM RAIL
(Bottom Rail at Expansion Joint Shown)

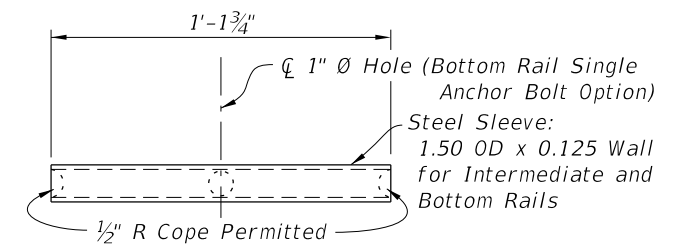

VIEW F-F
INTERMEDIATE OR BOTTOM RAIL -
STEEL SLEEVE DETAIL (Bottom Side Shown)

CROSS REFERENCE:

For location of Details "B", See Sheet 2.

9/26/2025 1:18:05 PM

| | | | | | | |
|---------------------------|--------------|--|--|---|-------------------------|------------------------|
| LAST REVISION 11/01/16 | DESCRIPTION: | | FY 2026-27 STANDARD PLANS | PEDESTRIAN/BICYCLE RAILING (STEEL) | INDEX 515-052 | SHEET 4 of 8 |
|---------------------------|--------------|--|--|---|-------------------------|------------------------|

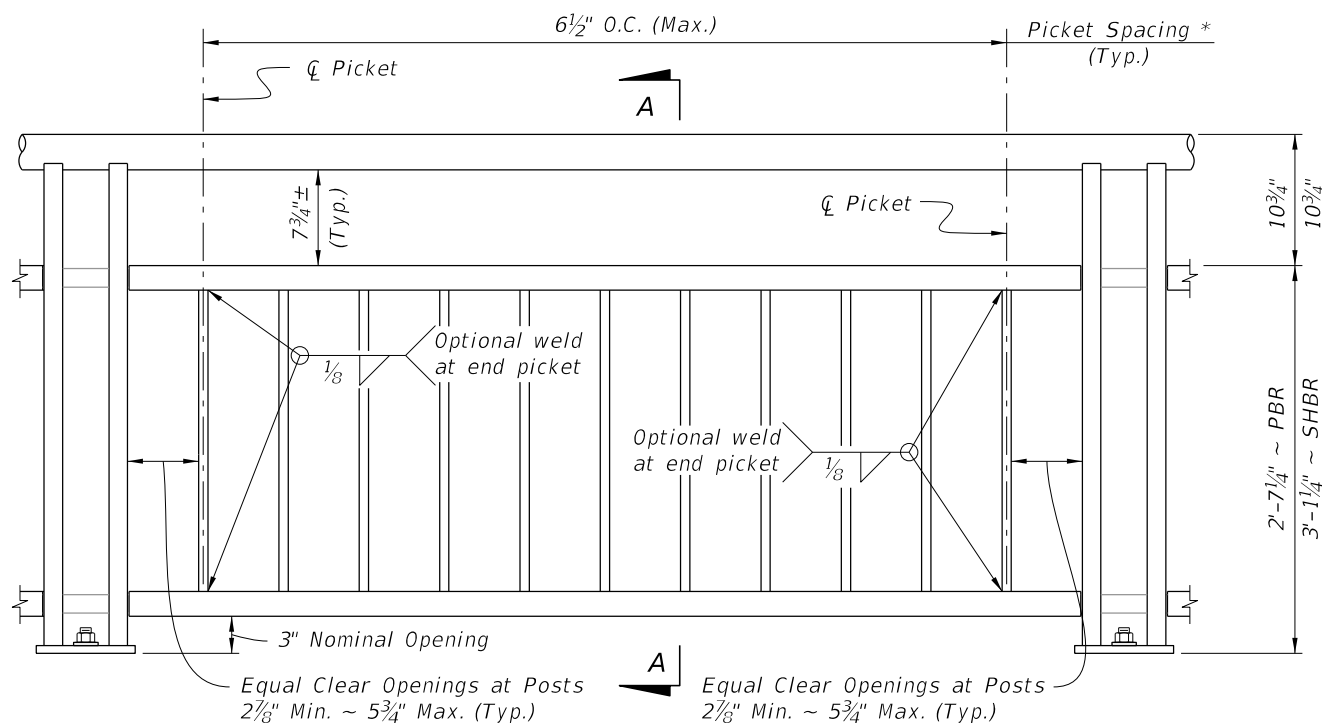

TYPE 1 - PICKET INFILL PANEL

PICKET NOTES:

* Picket Spacing of 6 1/2" centers is based on a 3/4" Ø Bar for standard applications. When shown in the Contract Plans a 4 1/2" picket spacing may be required. See Note 4 (Sheet 1).

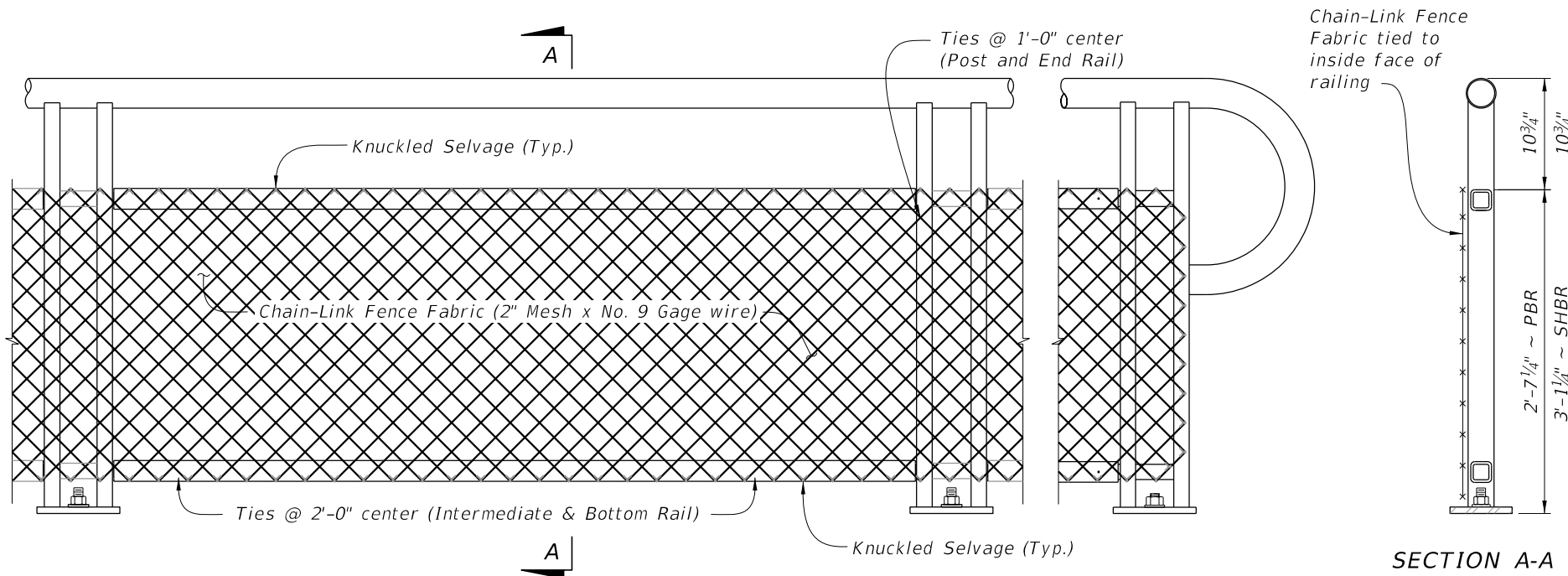

TYPE 2 - CHAIN-LINK (Continuous Infill Panel)

NOTES:

1. See Plans for Infill Panel option required.

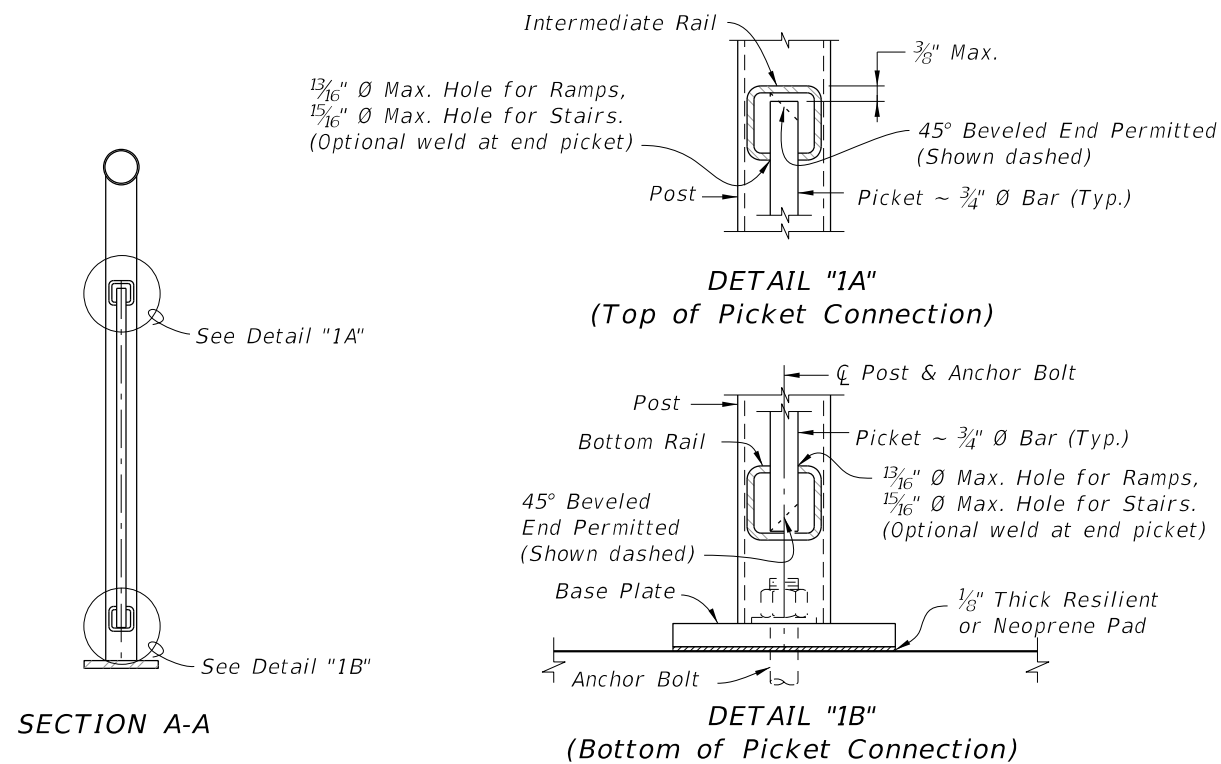

| TABLE 2 - CHAIN-LINK PANEL COMPONENT MATERIALS | | |
|--|-------|--|
| COMPONENT | ASTM | COMPONENT INFORMATION |
| Chain-Link Fence Fabric (2" mesh with knuckled top and bottom selvage) | A 392 | Zinc-Coated Steel - No. 9 gage (coated wire diameter), Class 2 Coating |
| | A 491 | Aluminum-Coated Steel - No. 9 gage (coated wire diameter) |
| | F 668 | Polyvinyl Chloride (PVC) Coated Steel - No. 9 gage Zinc-Coated Wire (metallic-coated core wire diameter) ~ See Plans for specified color of PVC. |
| Tie Wires | F 626 | Zinc-Coated Steel Wire - No. 9 gage with coating to match Chain-Link Fence Fabric. |
| Tension Bars | F 626 | 3/16" (Min. thickness) x 3/4" (Min. width) x 2'-3' (Min. height) Steel Bars |
| Miscellaneous Fence Components | F 626 | Zinc-Coated Steel |

CHAIN-LINK PANEL NOTE:

Chain-Link Fence Fabric shall be continuous along limits of railing. Splicing of Chain-Link panels using Tension Bars at 20'-0" minimum increments is permitted.

9/26/2025 1:18:12 PM

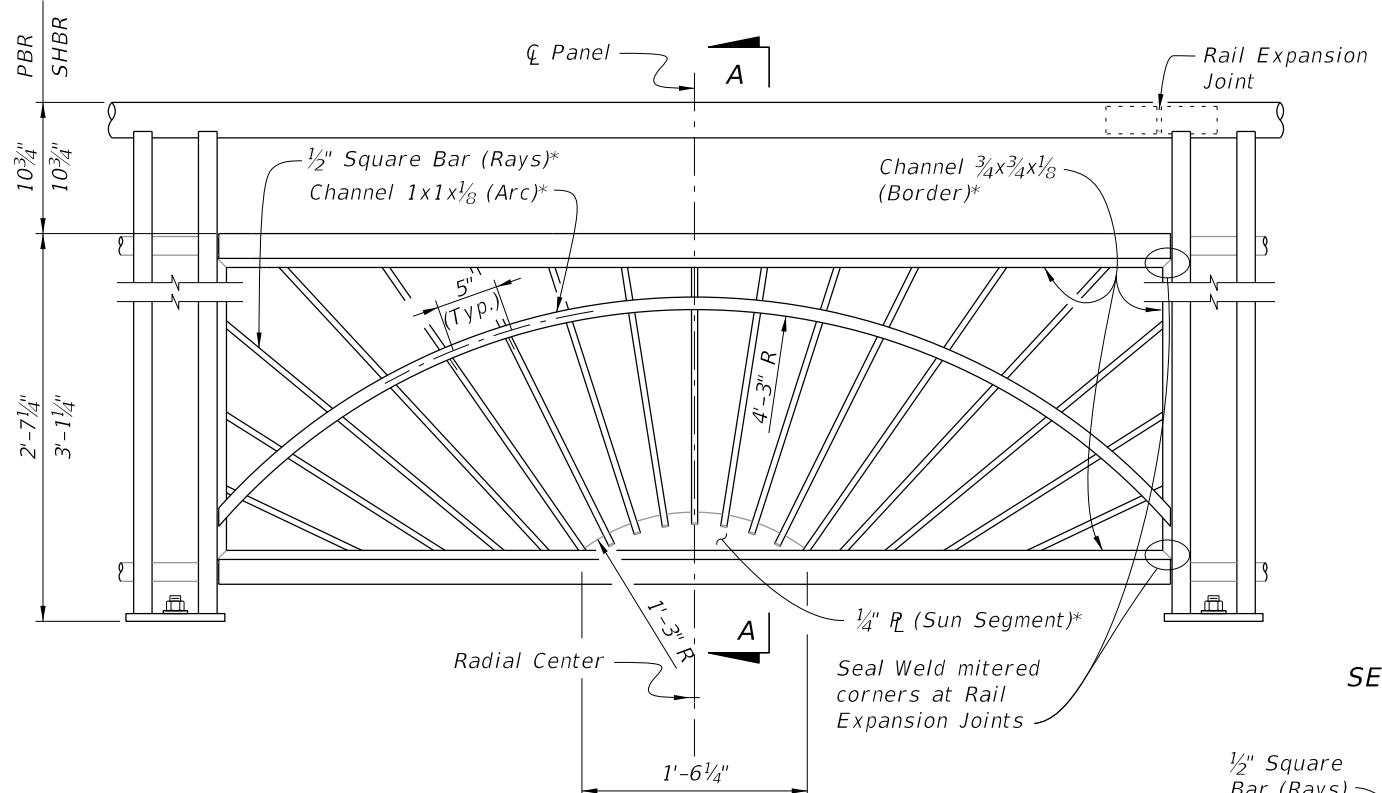

TYPE 3 - SUNSHINE INFILL PANEL

* Arc, Rays and Sun Segment may be formed in a single panel from 1/2" steel plate pattern cut with laser or plasma CNC, welded to a 1x1x1/8 Angle Border or the 3/4x3/4x1/8 Channel Border shown.

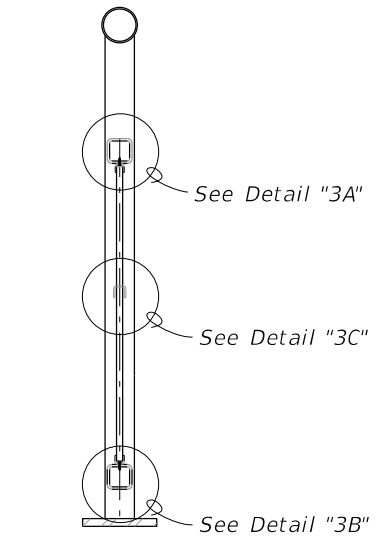

SECTION A-A

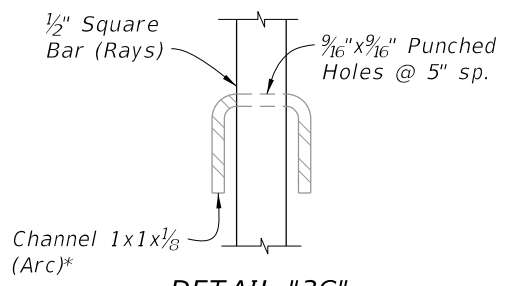

DETAIL "3C" RAY/ARC CONNECTION

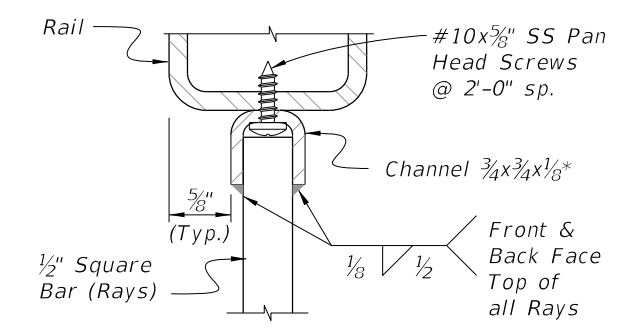

DETAIL "3A" INTERMEDIATE RAIL/RAY CONNECTION

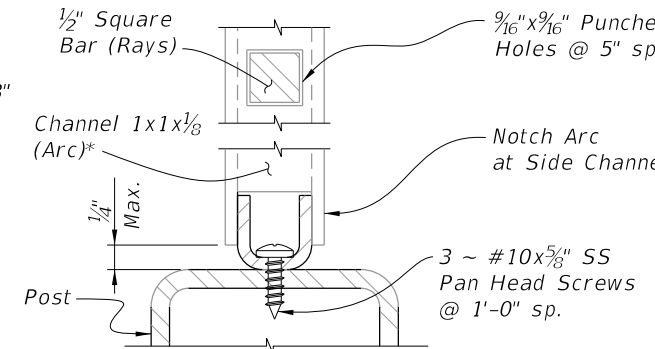

DETAIL "3D" ARC/POST CONNECTION (Continuous Top Rail)

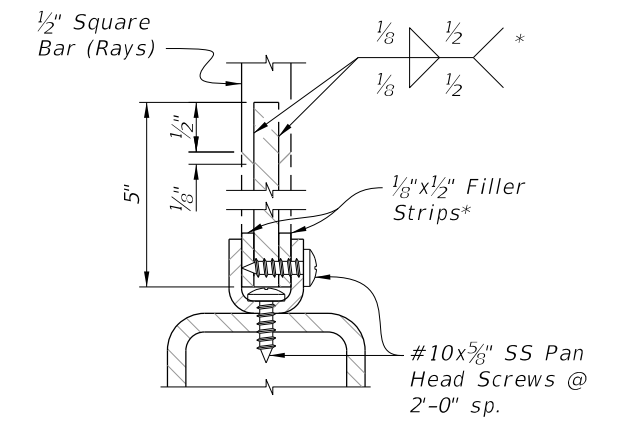

DETAIL "3B" BOTTOM RAIL/RAY CONNECTION

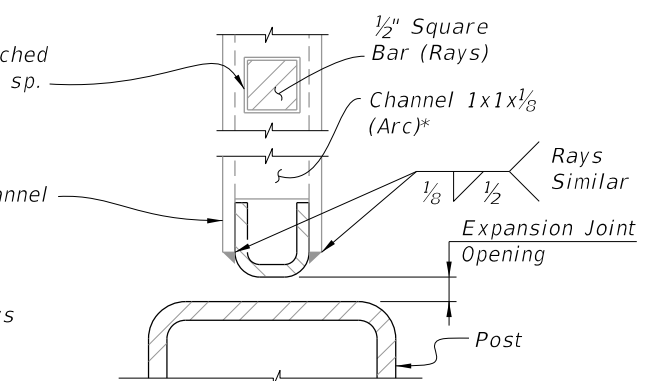

DETAIL "3E" PANEL END CONNECTION AT POST WITH EXPANSION JOINT

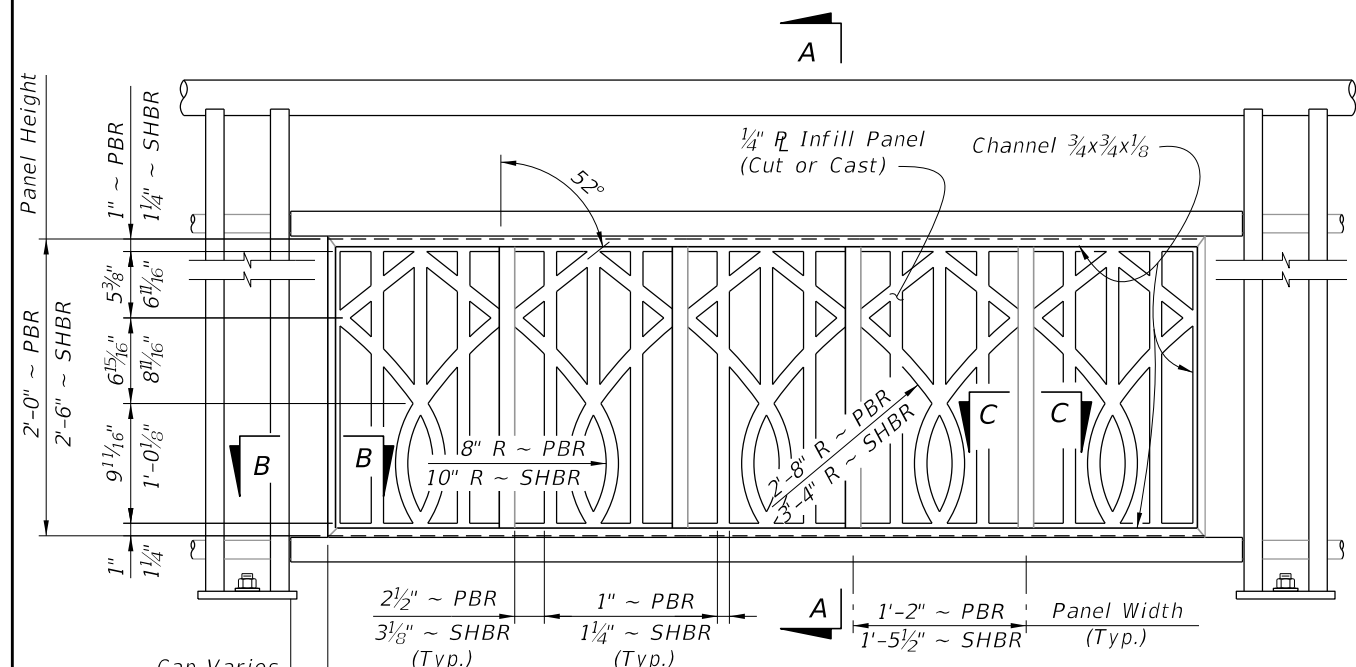

TYPE 4 - BROADWAY INFILL PANEL

NOTE: See Plans for Infill Panel Option required.

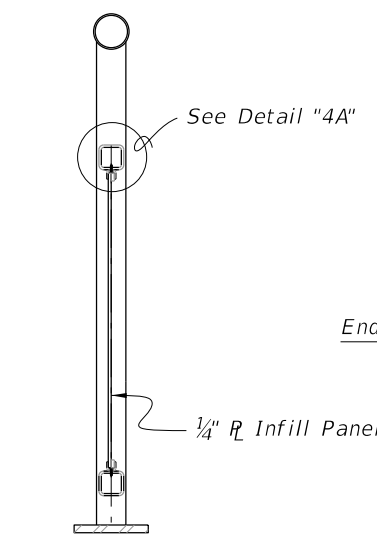

SECTION A-A

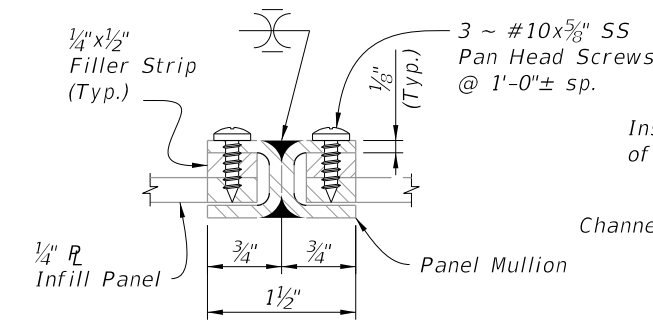

SECTION C-C PANEL/SPLICE CONNECTION

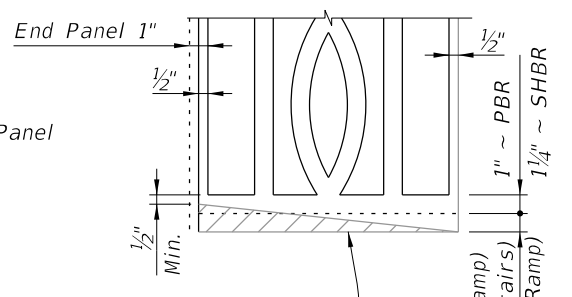

PANEL ADJUSTMENT FOR RAILINGS ON GRADES

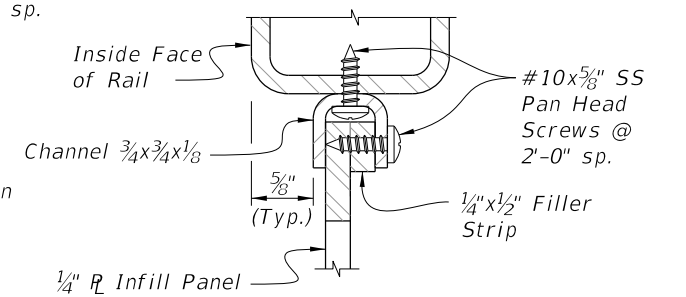

DETAIL "4A" PANEL/RAIL CONNECTION (Top Shown, Bottom Similar)

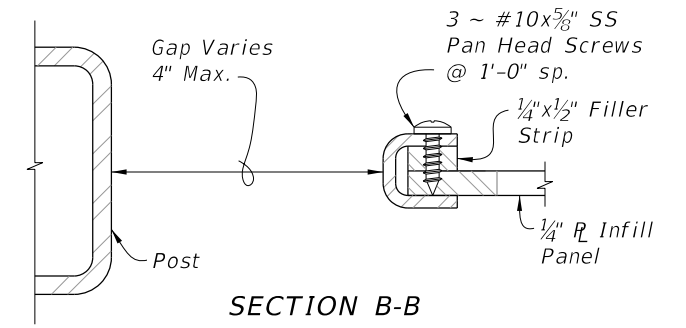

SECTION B-B PANEL END CAP

9/26/2025 1:18:19 PM

| | | | | | | |
|---------------------------|--------------|--|------------------------------|------------------------------------|---------|--------|
| LAST REVISION 11/01/16 | DESCRIPTION: | | FY 2026-27 STANDARD PLANS | PEDESTRIAN/BICYCLE RAILING (STEEL) | INDEX | SHEET |
| | | | | | 515-052 | 6 of 8 |

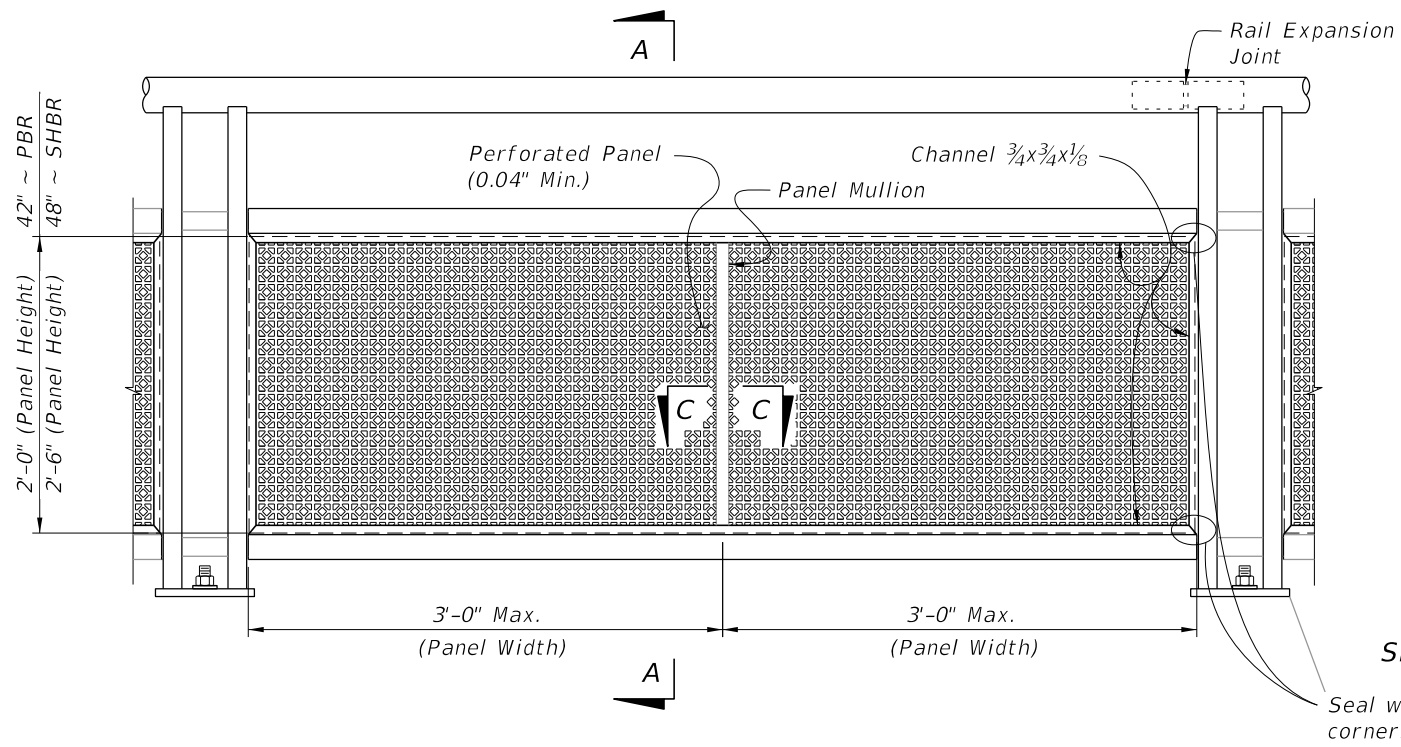

TYPE 5 - PERFORATED INFILL PANEL

SECTION A-A

Seal welding mitered corners is permitted

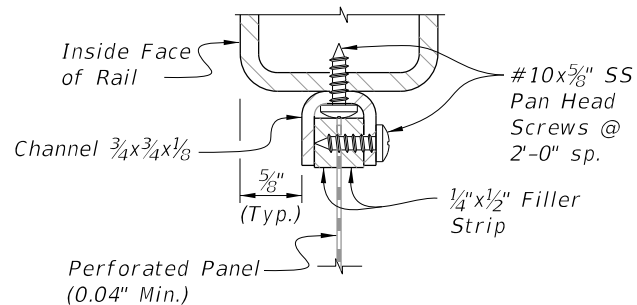

DETAIL "5A"
PANEL/RAIL CONNECTION
(Top Shown, Bottom Similar)

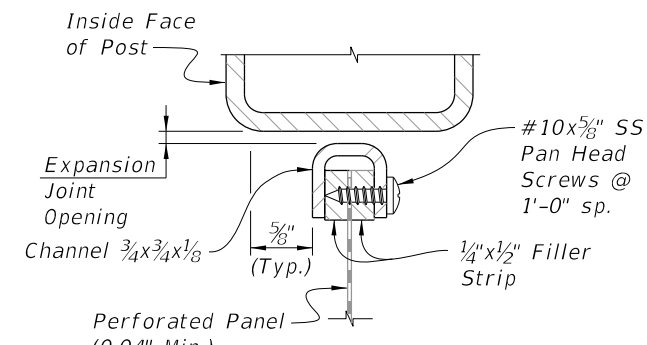

DETAIL "5B"
PANEL END CONNECTION
(Expansion Joint Shown, Sides Similar)

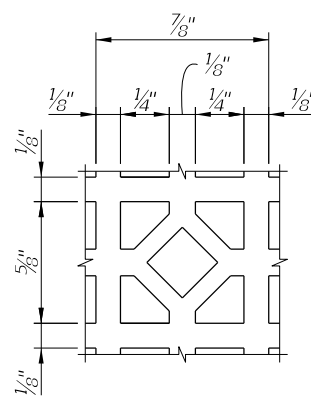

REPEATING PATTERN DETAIL
FOR PERFORATED PANEL

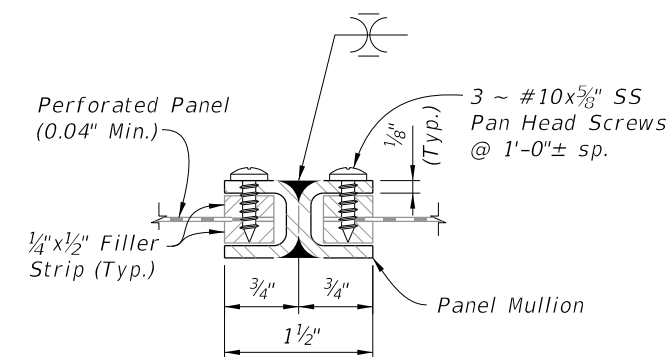

SECTION C-C
PANEL/SPLICE CONNECTION

NOTES:

1. See Plans for Infill Panel Type required.

9/26/2025 1:18:26 PM

| | | | | | | | |
|---------------------------|----------|--------------|---|------------------------------|------------------------------------|------------------|-----------------|
| LAST REVISION 11/01/16 | REVISION | DESCRIPTION: |  | FY 2026-27 STANDARD PLANS | PEDESTRIAN/BICYCLE RAILING (STEEL) | INDEX 515-052 | SHEET 7 of 8 |
|---------------------------|----------|--------------|---|------------------------------|------------------------------------|------------------|-----------------|

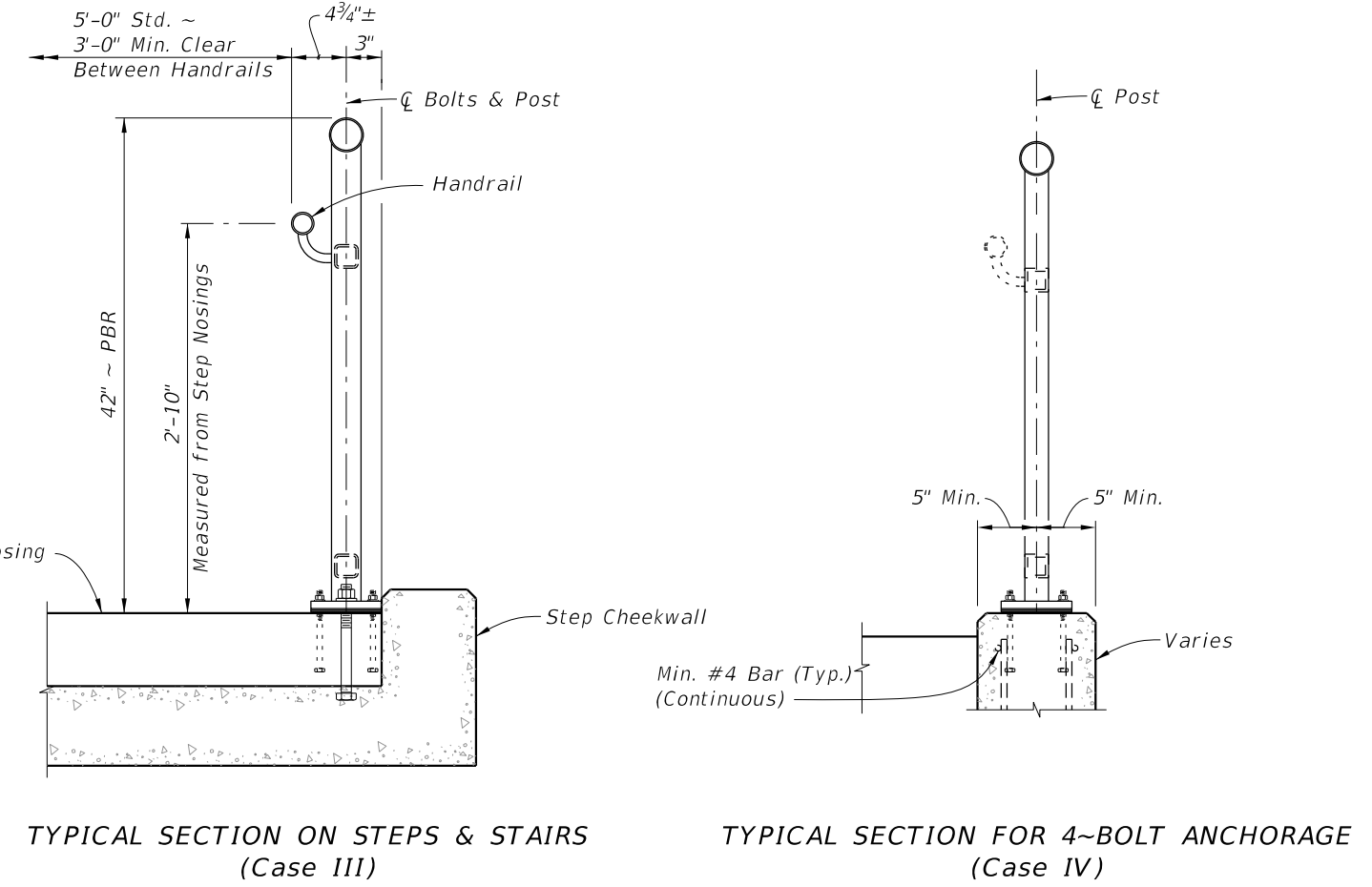
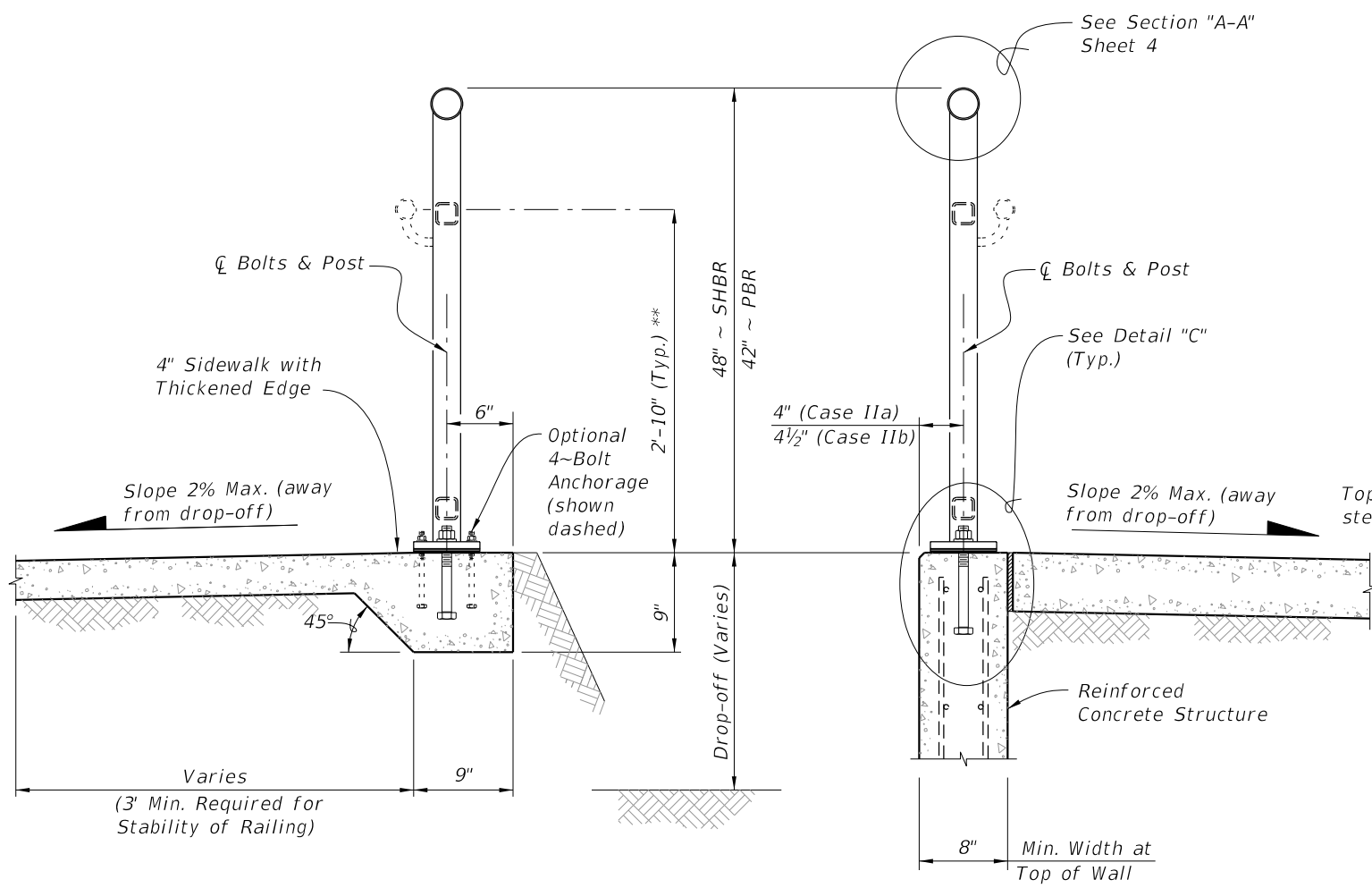

TYPICAL SECTION ON CONCRETE SIDEWALK (Case I)

TYPICAL SECTION ON RETAINING WALL (Case II)

TYPICAL SECTION ON STEPS & STAIRS (Case III)

TYPICAL SECTION FOR 4-BOLT ANCHORAGE (Case IV)

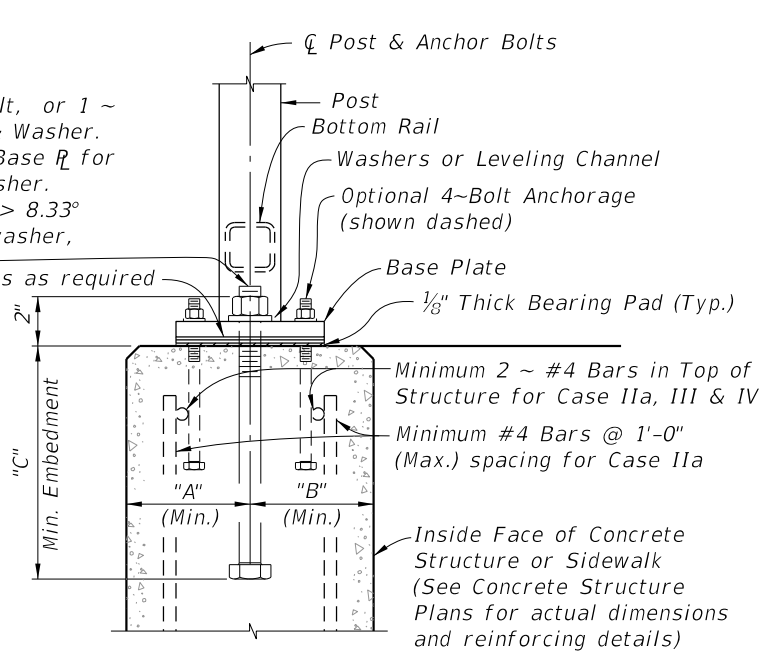
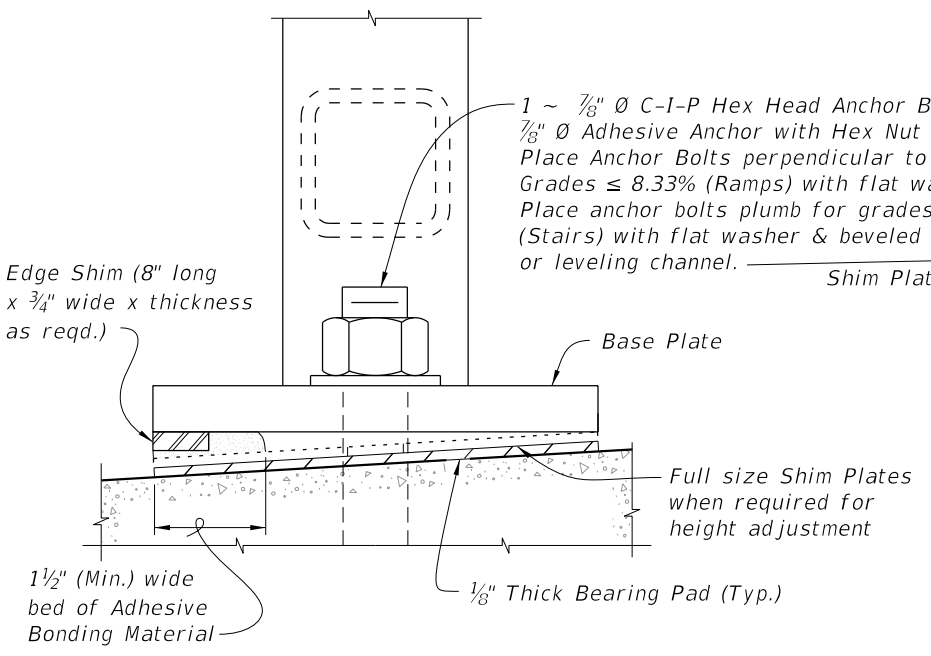

| CASE | STRUCTURE TYPE | DIMENSIONS | | | ANCHOR LENGTH | | ANCHOR SIZE |
|------|----------------------------|------------|--------------|-----------|---------------------|-----------------|-------------|
| | | A | B | C | C-I-P Hex Head Bolt | Adhesive Anchor | |
| | | Edge Dist. | Edge Dist. | Embedment | | | |
| I | Unreinforced Concrete | 6" | 1'-2" | 6" | 7 1/2" | 8" | 7/8" Ø |
| IIa | Reinforced Concrete | 4" | 4" | 9" | 10 1/2" | 11" | 7/8" Ø |
| IIb | Gravity Wall Index 400-011 | 4 1/2" | 3 1/2" @ top | 9" | 10 1/2" | 11" | 7/8" Ø |
| III | Step Cheekwall | 4 1/2" | 4 1/2" | 9" | 10 1/2" | 11" | 7/8" Ø |
| IV | Varies | 5" | 5" | 5" | 6 1/2" | 7" | 7/16" Ø |

** When required; measured from top of sidewalk.

9/26/2025 1:18:32 PM