

**PARTIAL PLAN OF RAILING**

☐ Post Bolts and Match Line (Trailing End) (See Sheets 3 and 4)

☐ Post Bolts and Match Line (Approach End) (See Sheets 3 and 4)

6'-3" spacing (Typ. except as noted along Bridge, see Note 2)

1'-6" Min. for non skewed joints. For treatment of skewed Intermediate Deck Joints see Skew Detail Index 460-470, Sheet 2 (Typ.)

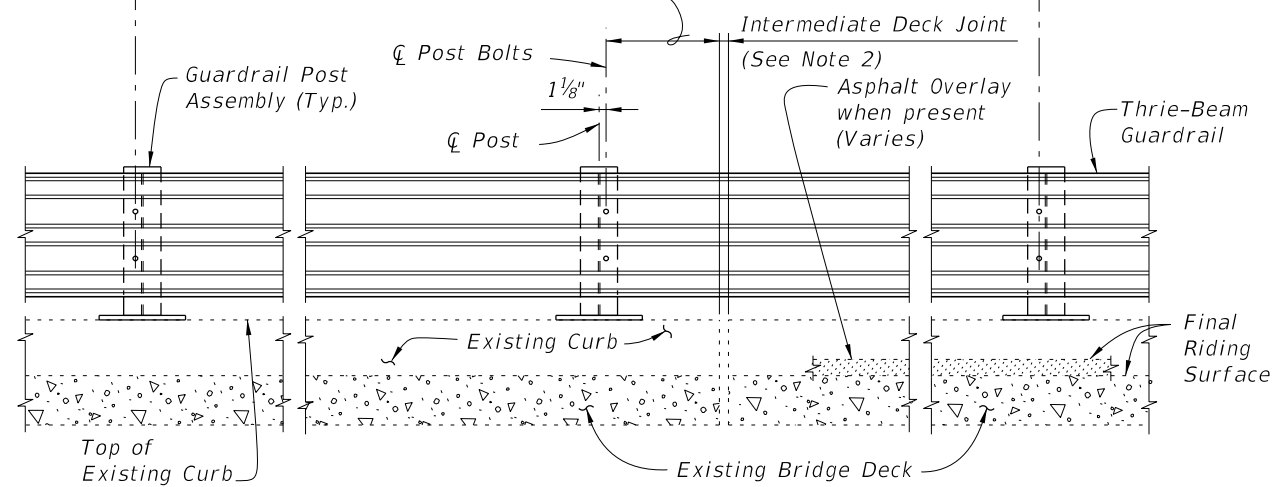

**PARTIAL ELEVATION OF INSIDE FACE OF RAILING**  
(Existing Traffic Railing not shown for clarity)

===== TYPICAL TREATMENT OF RAILING ALONG BRIDGE =====

**NOTES:**

1. On approach end provide Index 536-002 (as shown) or other site specific treatment, see Roadway Plans. For treatment of trailing end see Roadway Plans.
2. Actual joint dimension and orientation vary. For Intermediate Deck Joints use the Modified Post Spacing at Intermediate Deck Joints Detail, Index 460-470, Sheet 2, as required.
3. Areas where existing structure has been removed shall match adjoining areas and shall be finished flat by grouting or grinding as required. Exposed existing reinforcing steel shall be burned off 1" below existing concrete and grouted over.

**CROSS REFERENCES:**  
For Section A-A see Sheet 2.  
For Traffic Railing Notes and Details see Index 460-470.

10/6/2025 2:59:56 PM

LAST REVISION 01/01/08	REVISION	DESCRIPTION:		FY 2026-27 STANDARD PLANS	<b>TRAFFIC RAILING - (THRIE-BEAM RETROFIT) WIDE STRONG CURB TYPE 2</b>	INDEX 460-473	SHEET 1 of 4
---------------------------	----------	--------------	--	------------------------------	--	------------------	-----------------

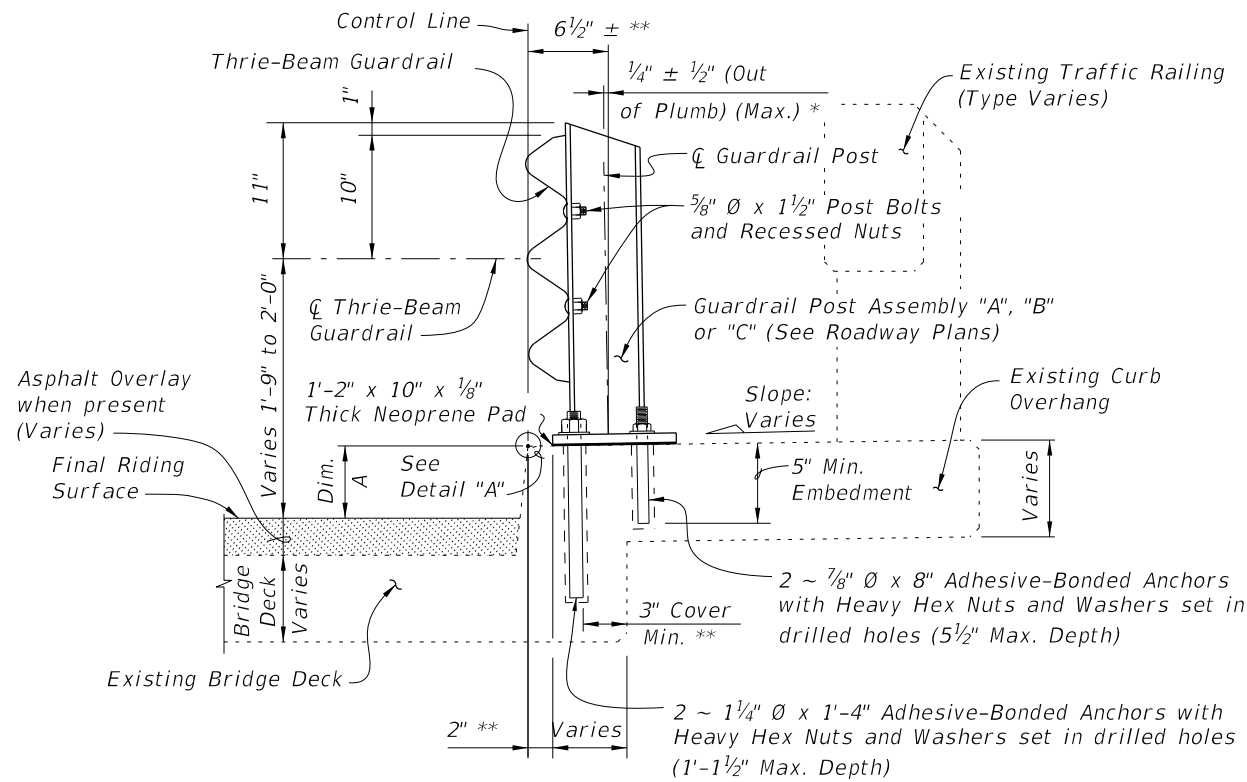

**SECTION A-A**  
TYPICAL SECTION THRU RAILING ON BRIDGE DECK

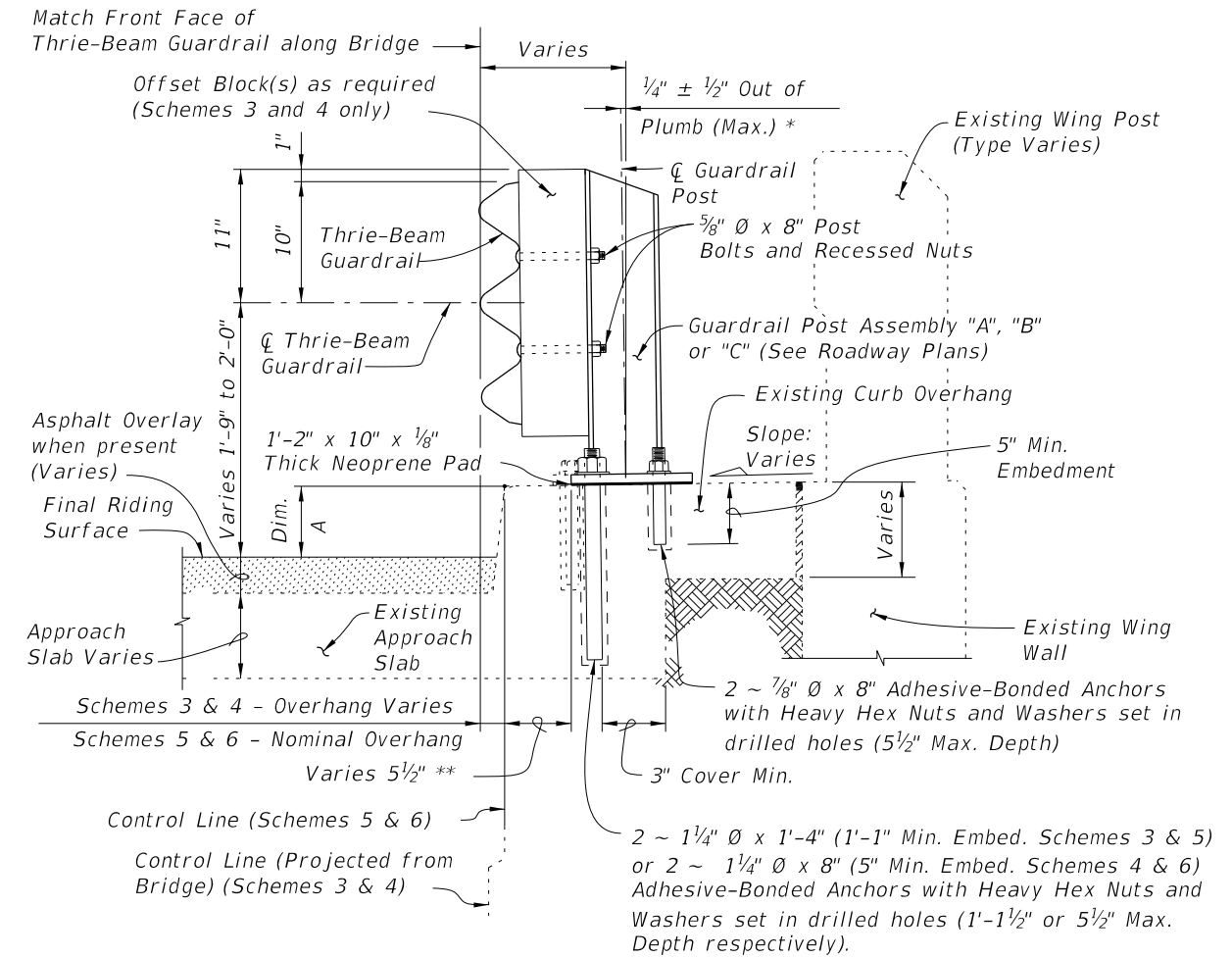

**SECTION B-B**  
TYPICAL SECTION THRU RAILING ALONG APPROACH SLAB  
(SCHEMES 5 AND 6 SHOWN, SCHEMES 3 AND 4 SIMILAR)  
(Adhesive Anchor Option shown solid, Screw Anchor Option shown dashed)

BILL OF REINFORCING STEEL			BAR BENDING DIAGRAMS	
MARK	SIZE	LENGTH		
D	4	3'-7"		
L	4	4'-1"		
M	4	2'-8"		

NOTE: All bar dimensions are out to out.

\* Shim with washers around Anchor Bolts and Anchors as required to maintain tolerance.  
 \*\* Offset may vary  $\pm 1"$  for Adhesive-Bonded Anchors and Anchor Bolts to clear existing curb reinforcing and provide minimum edge clearance. Offset shall be consistent along length of bridge.

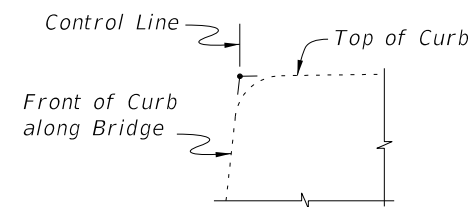

DETAIL "A"

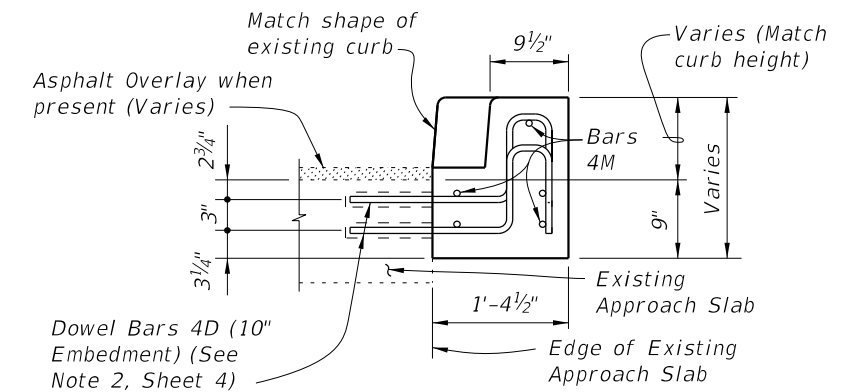

VIEW C-C

CROSS REFERENCES:  
 For location of Section A-A see Sheet 1, 3 and 4.  
 For location of Section B-B see Sheet 4.  
 For location of View C-C see Sheet 3.  
 For Traffic Railing Notes and Details see Index 460-470.  
 For application of Dim. A see Post Dimension Table on Index 460-470, Sheet 3.

10/16/2025 3:00:02 PM

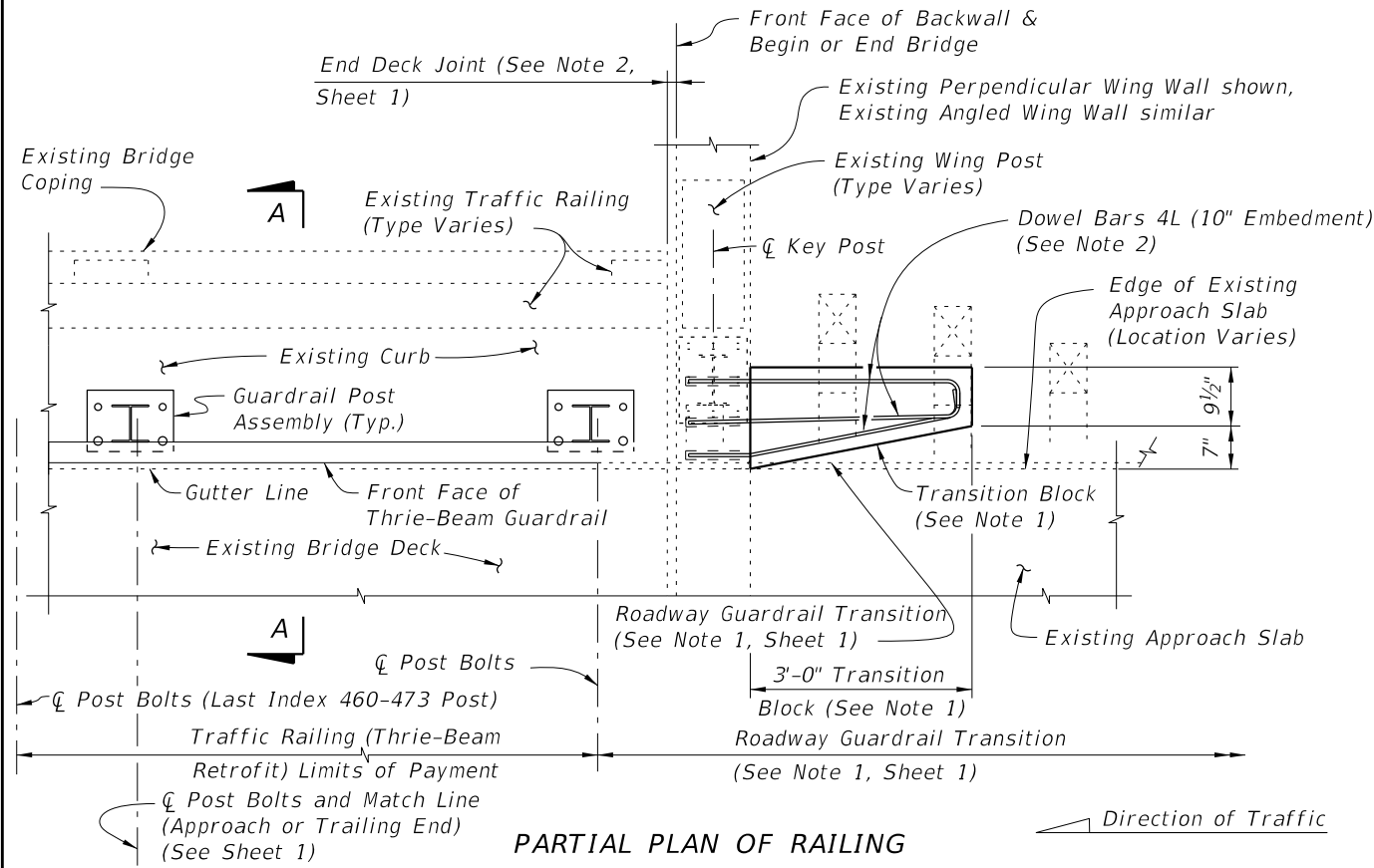

**PARTIAL PLAN OF RAILING**

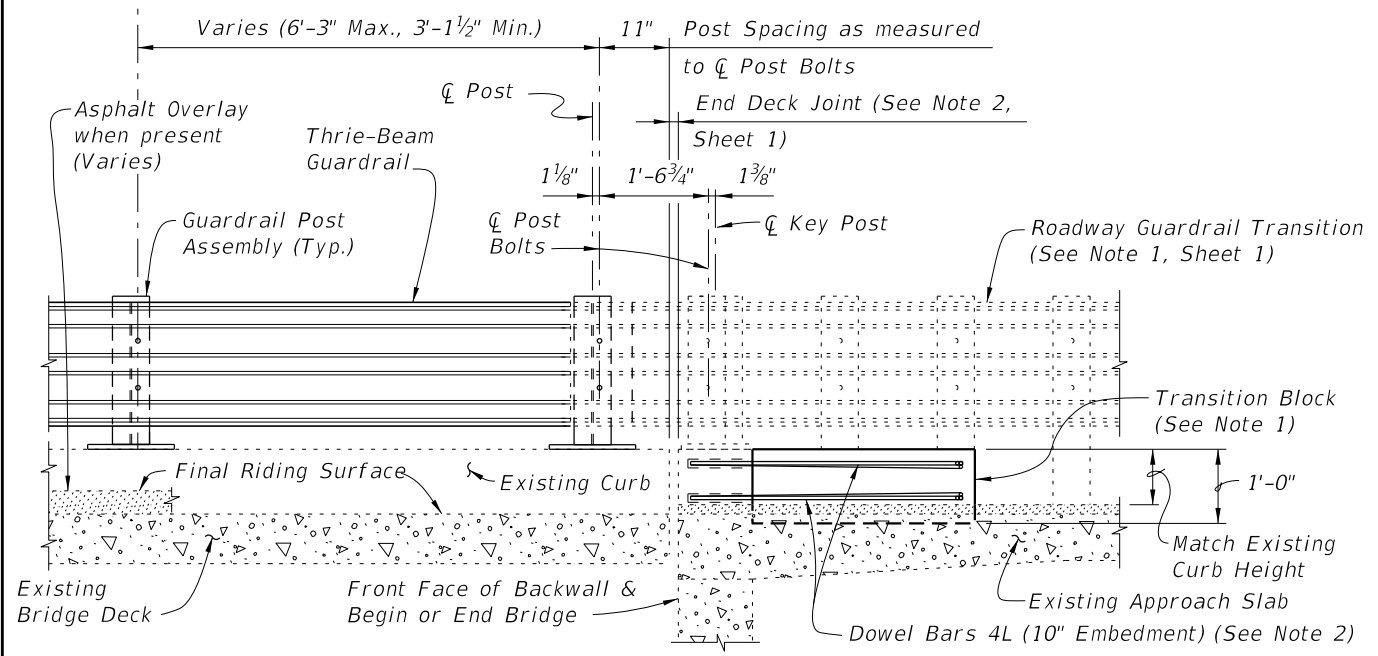

**PARTIAL ELEVATION OF INSIDE FACE OF RAILING  
(Existing Wing Post and Traffic Railing not shown for clarity)**

**SCHEME 1  
RAILING END TREATMENT FOR PERPENDICULAR OR ANGLED WING WALLS**

- SCHEME 1 NOTES:**
1. Provide Transition Block (as shown) or Curb if existing Approach Slab does not have a curb, see Roadway Plans. Shape and height of Transition Block or Curb shall match existing bridge curb. Transition Block may be omitted on trailing ends with no opposing traffic.
  2. Field bend Dowel Bars 4L within Transition Block as required to maintain 2" top and side clearance and 3" bottom clearance.

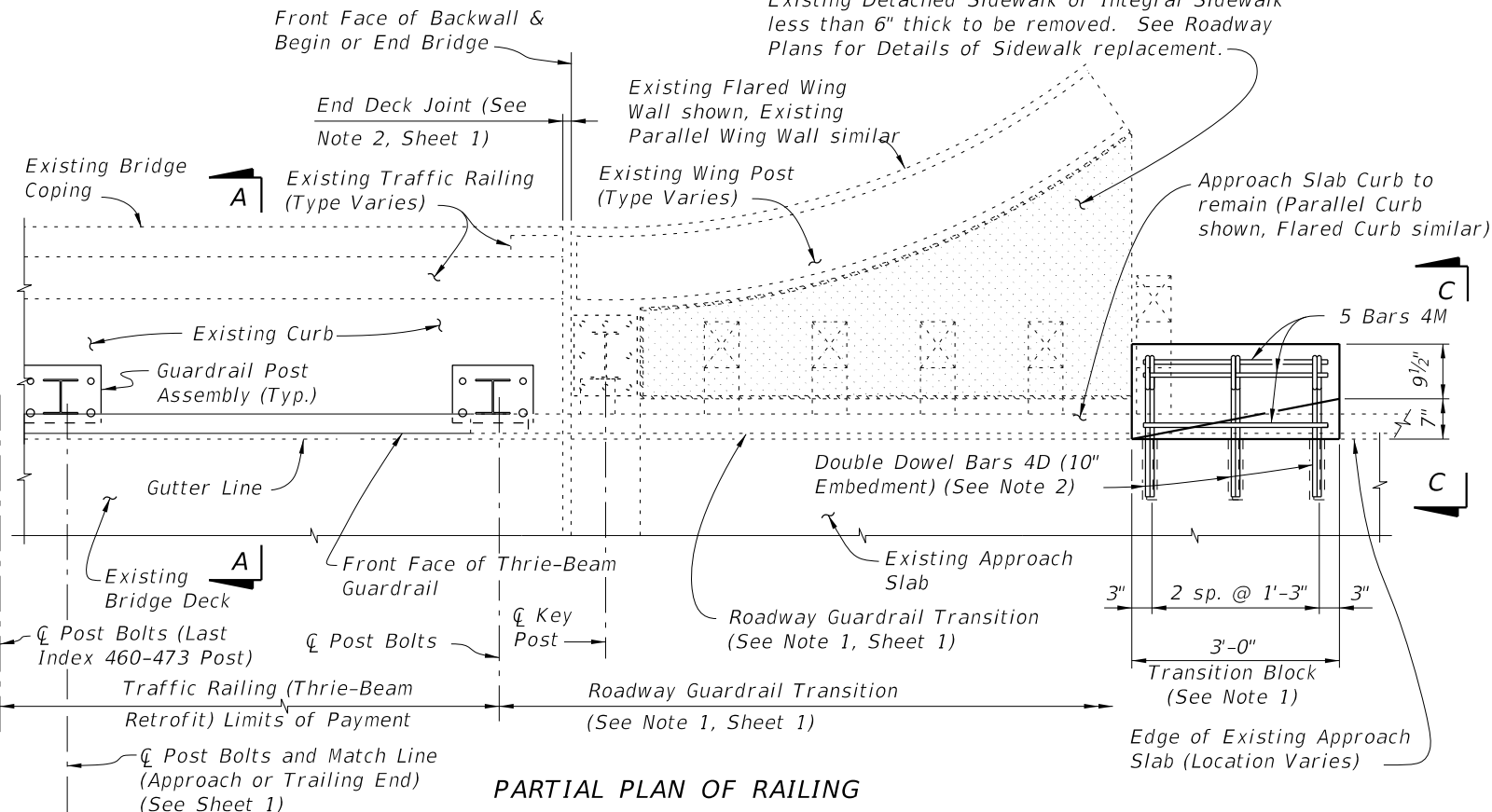

**PARTIAL PLAN OF RAILING**

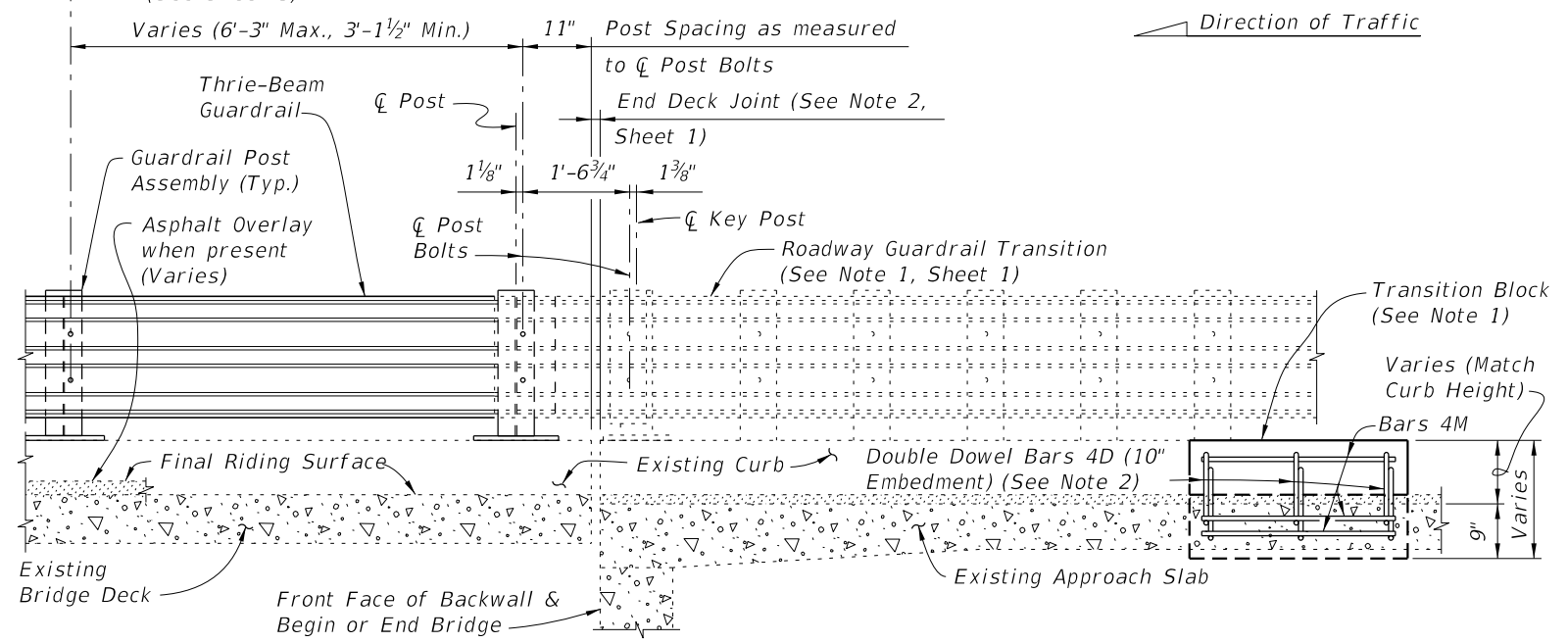

**PARTIAL ELEVATION OF INSIDE FACE OF RAILING  
(Existing Wing Post and Traffic Railing not shown for clarity)**

**SCHEME 2  
RAILING END TREATMENT FOR PARALLEL OR FLARED CURBS WITH DETACHED SIDEWALKS OR INTEGRAL SIDEWALK LESS THAN 6" THICK**

- SCHEME 2 NOTES:**
1. Provide Transition Block (as shown) or Curb if existing Approach Slab Curb does not extend to end of Approach Slab. Shape and height of Transition Block or Curb shall match existing bridge curb. Transition Block may be omitted on trailing ends with no opposing traffic and on bridges with flared Approach Slab Curbs.
  2. Field bend or tilt Dowel Bars 4D and Bars 4M within Transition Block as required to maintain 2" top and side clearance and 3" bottom clearance.

10/16/2025 3:00:09 PM

LAST REVISION 01/01/08	REVISION	DESCRIPTION:		<b>FY 2026-27 STANDARD PLANS</b>	<b>TRAFFIC RAILING - (THRIE-BEAM RETROFIT) WIDE STRONG CURB TYPE 2</b>	INDEX 460-473	SHEET 3 of 4
---------------------------	----------	--------------	--	--------------------------------------	--	------------------	-----------------

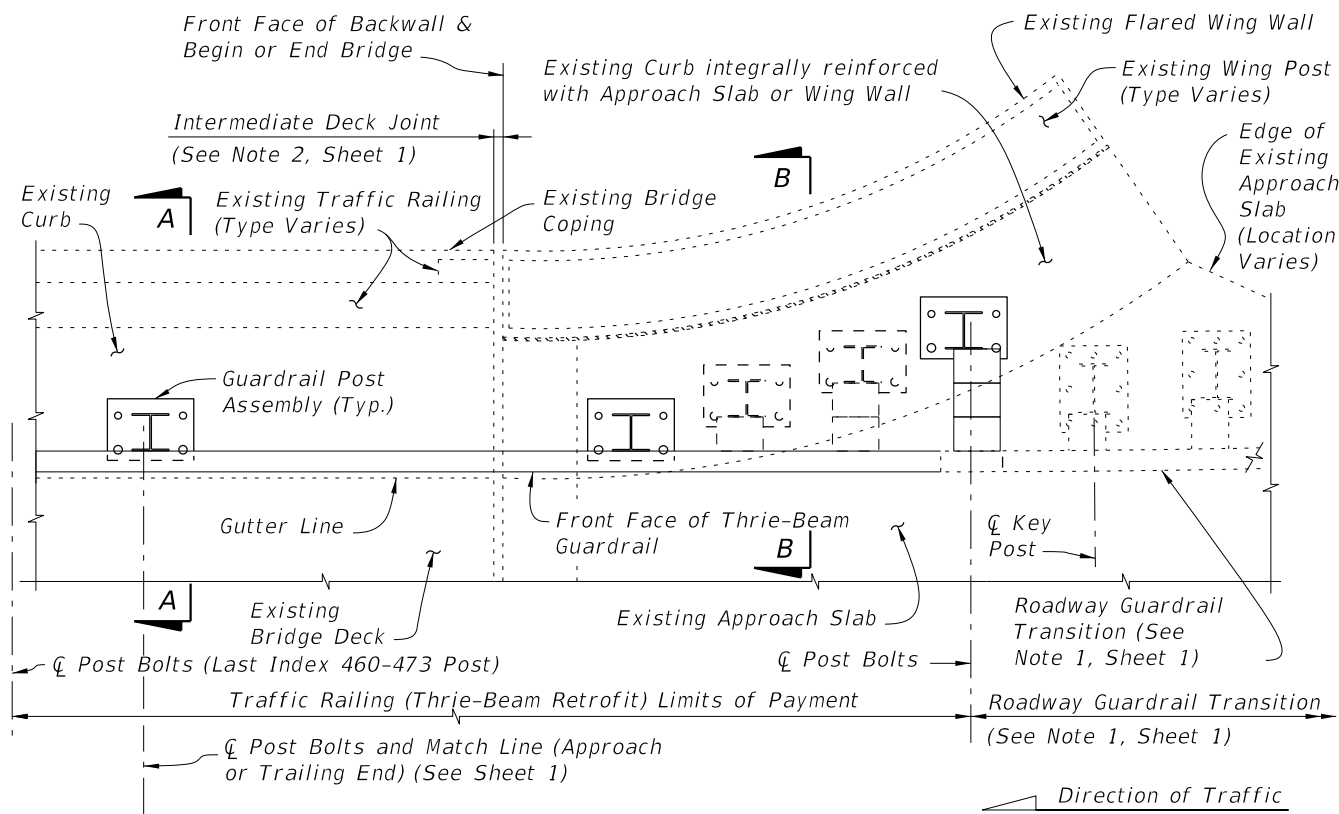

**PARTIAL PLAN OF RAILING**

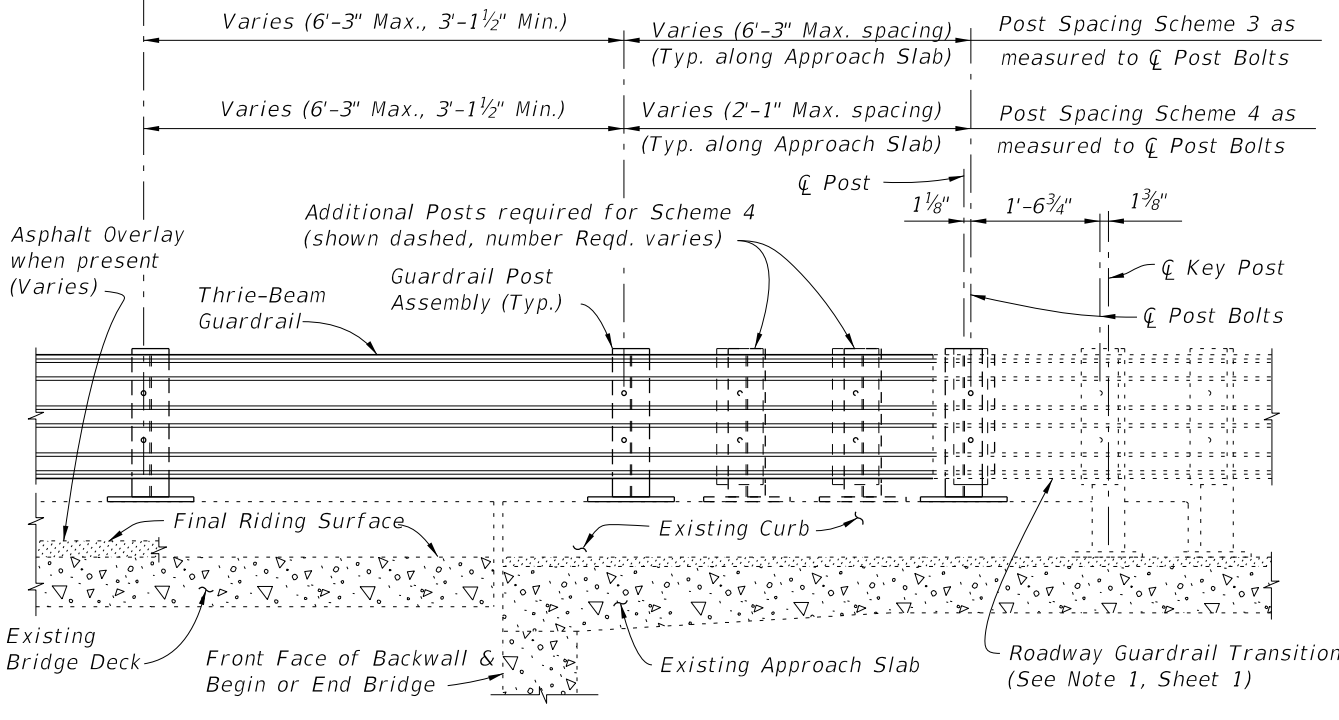

**PARTIAL ELEVATION OF INSIDE FACE OF RAILING**  
(Existing Wing Post and Traffic Railing not shown for clarity)

**SCHEMES 3 AND 4**  
**RAILING END TREATMENT FOR FLARED INTEGRAL CURBS**

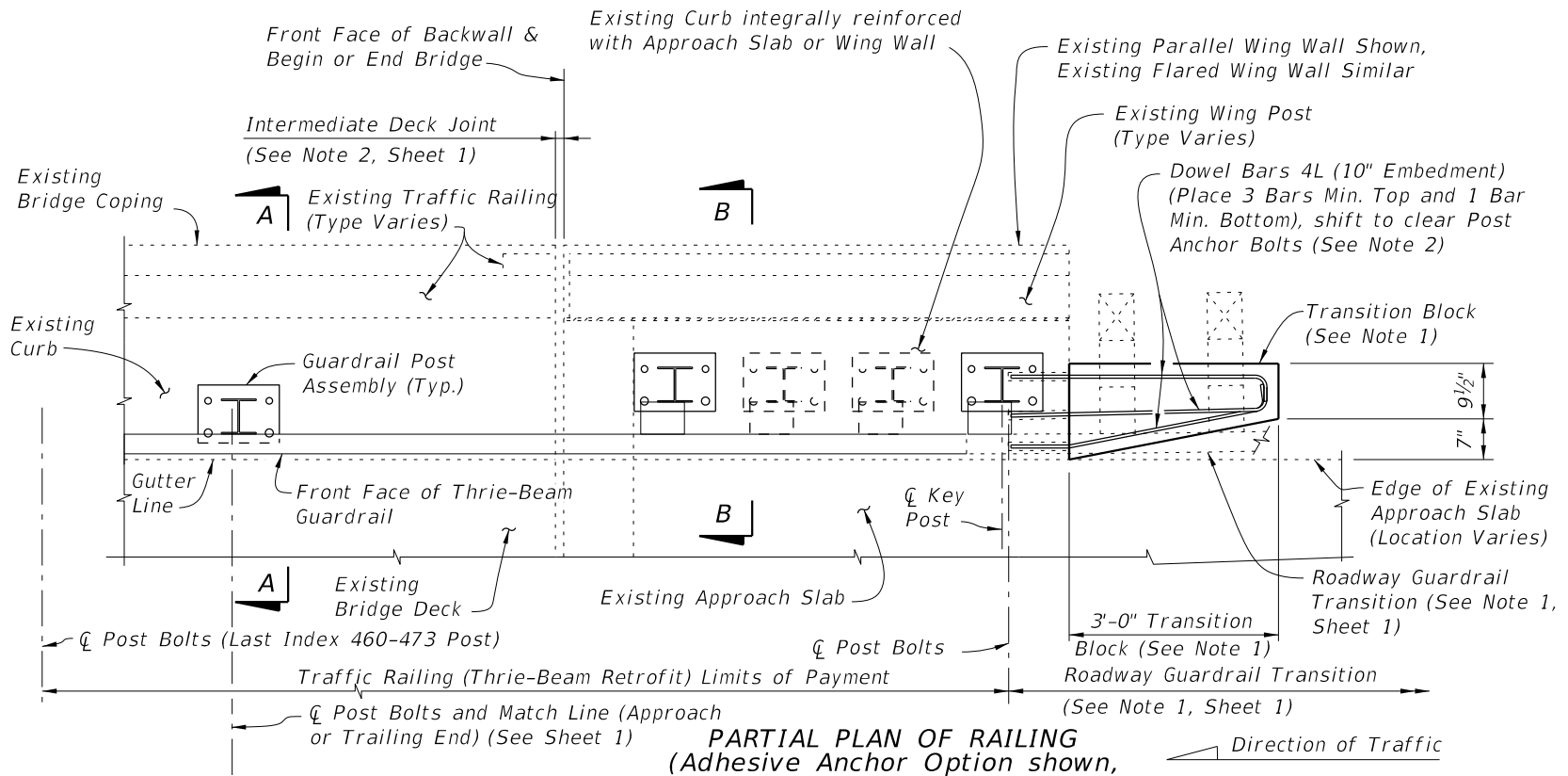

**PARTIAL PLAN OF RAILING**  
(Adhesive Anchor Option shown, Screw Anchor Option similar)

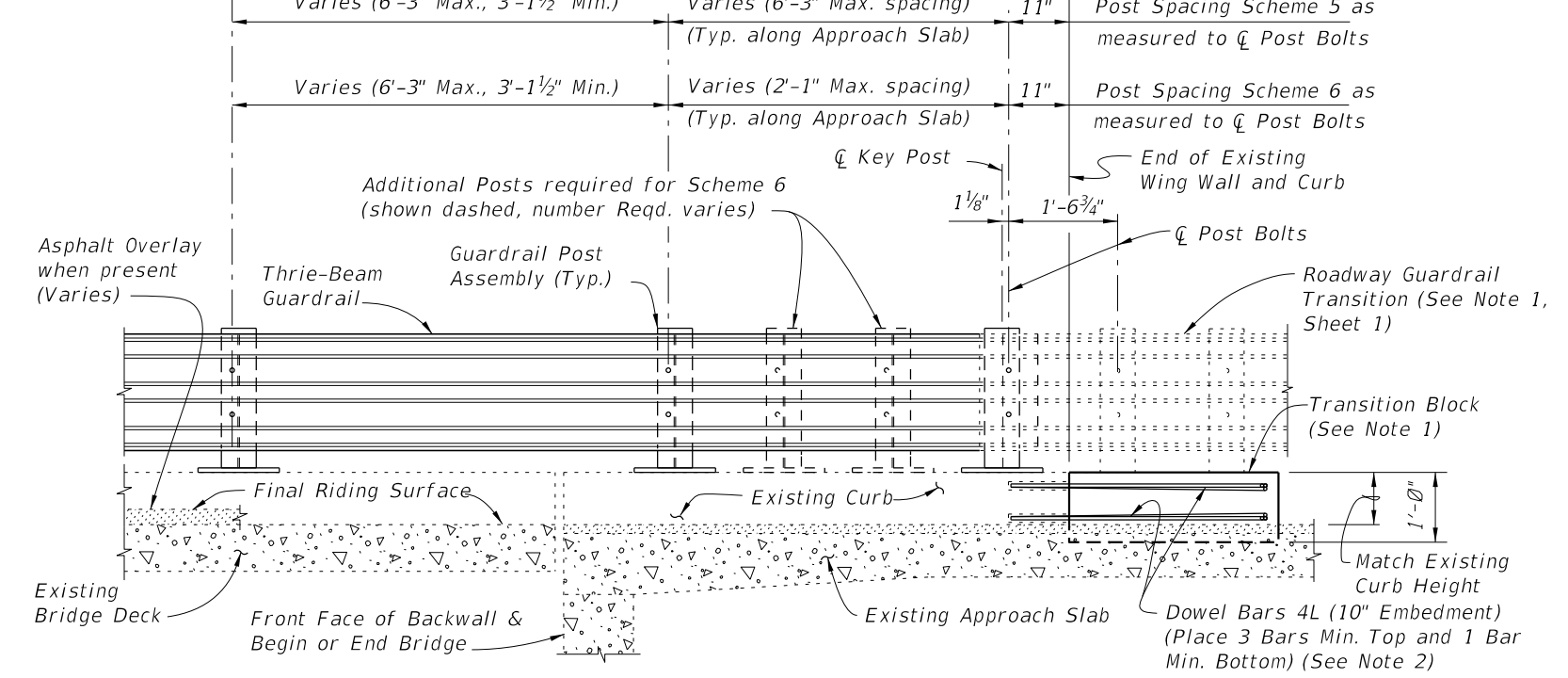

**PARTIAL ELEVATION OF INSIDE FACE OF RAILING**  
(Existing Wing Post and Traffic Railing not shown for clarity)

**SCHEMES 5 AND 6**  
**RAILING END TREATMENT FOR PARALLEL INTEGRAL CURBS**

- SCHEMES 5 AND 6 NOTES:**
1. Provide Transition Block (as shown) or Curb if existing Approach Slab Curb does not extend to end of Approach Slab. Shape and height of Transition Block or Curb shall match existing bridge curb. Transition Block may be omitted on trailing ends with no opposing traffic.
  2. Field bend Dowel Bars 4L within Transition Block as required to maintain 2" top and side clearance and 3" bottom clearance.

10/6/2025 3:00:15 PM

LAST REVISION 11/01/24	DESCRIPTION:		<b>FY 2026-27</b> <b>STANDARD PLANS</b>	<b>TRAFFIC RAILING - (THRIE-BEAM RETROFIT)</b> <b>WIDE STRONG CURB TYPE 2</b>	INDEX 460-473	SHEET 4 of 4
---------------------------	--------------	--	--	--	------------------	-----------------