

PARTIAL SECTION ALONG Q̄ JOINT
JOINT TREATMENT AT HIGH SIDE OF
DECK WITH SLOPES 1% OR GREATER

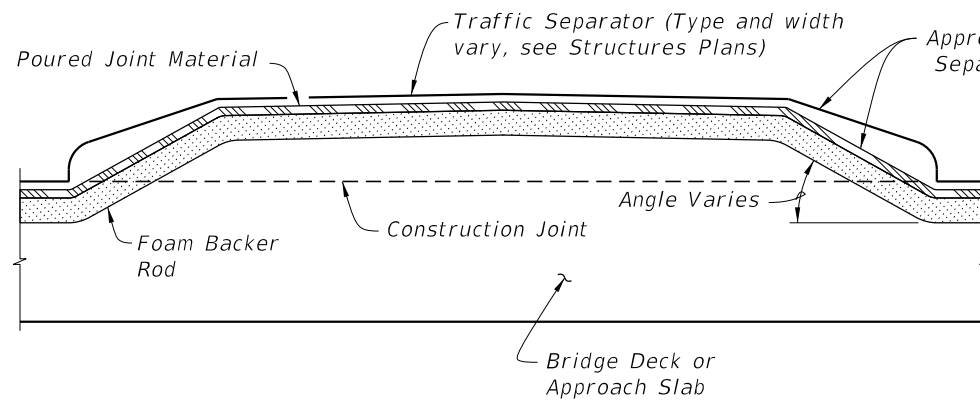

PARTIAL SECTION ALONG Q̄ JOINT,
JOINT TREATMENT AT TRAFFIC SEPARATOR

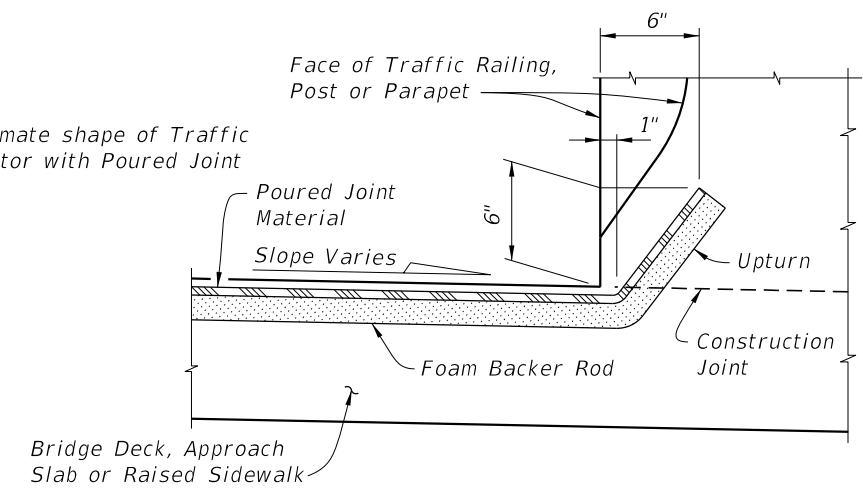

PARTIAL SECTION ALONG Q̄ JOINT
JOINT TREATMENT AT LOW SIDE OF DECK OR
HIGH SIDE OF DECK WITH SLOPES < 1%

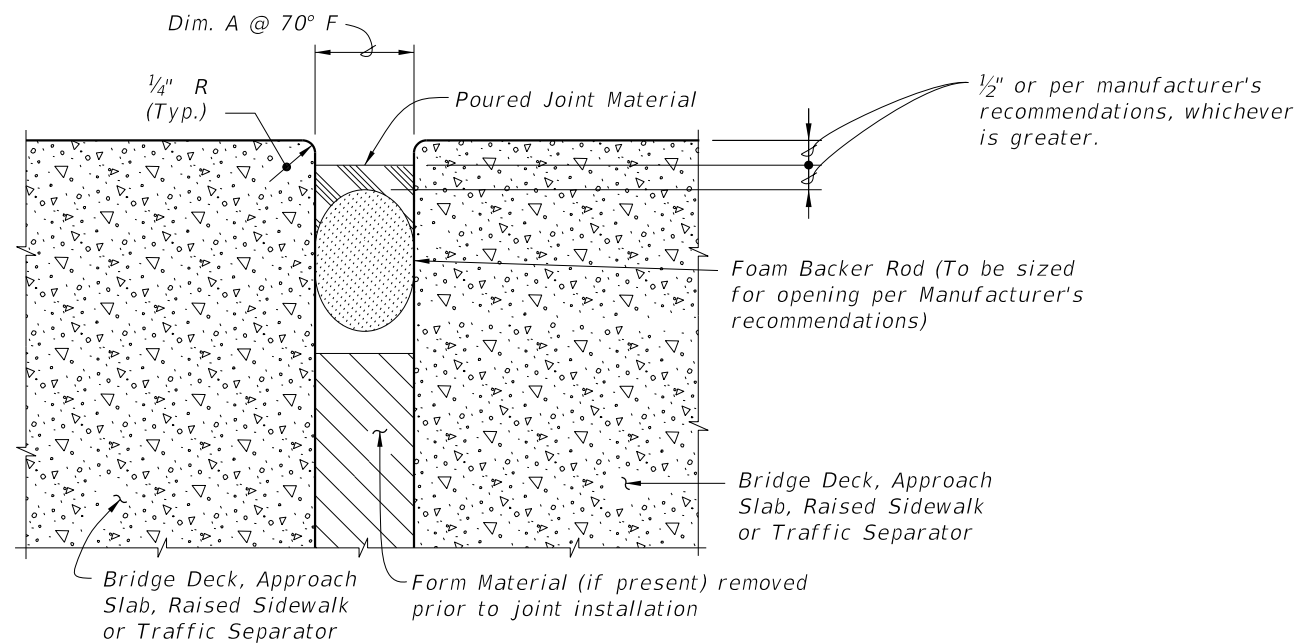

TYPICAL SECTION THRU JOINT

GENERAL NOTES:

1. Furnish and install Poured Joint With Backer Rod Expansion Joint Systems in accordance with Specification Sections 458 and 932 using Type D silicone sealant material.
2. Refer to the Structures Plans, Poured Expansion Joint Data Table for Dim. A @ 70° F.

10/6/2025 2:55:03 PM

LAST REVISION 11/01/23	REVISION	DESCRIPTION:		FY 2026-27 STANDARD PLANS	EXPANSION JOINT SYSTEM - POURED JOINT WITH BACKER ROD	INDEX 458-110	SHEET 1 of 2
---------------------------	----------	--------------	---	------------------------------	--	------------------	-----------------

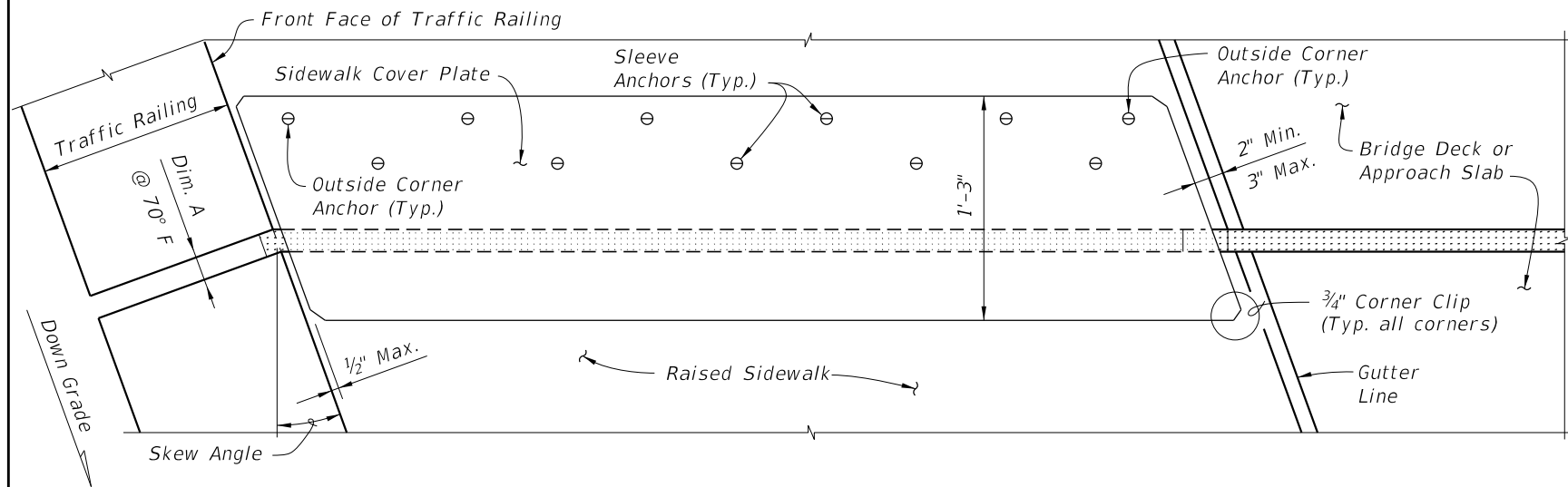

PARTIAL PLAN VIEW OF SKEWED JOINTS

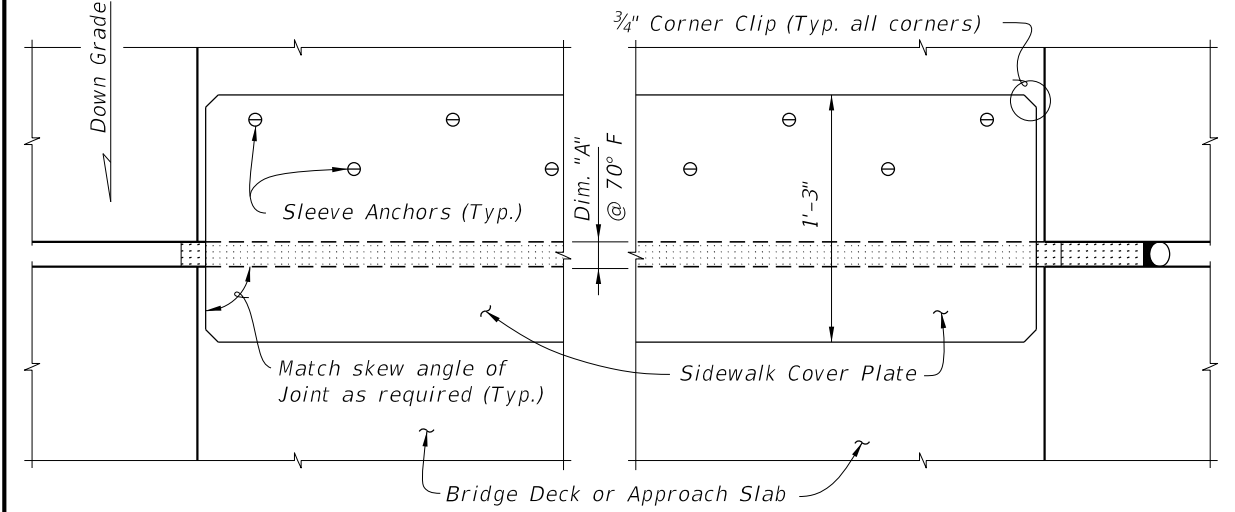

PARTIAL PLAN VIEW

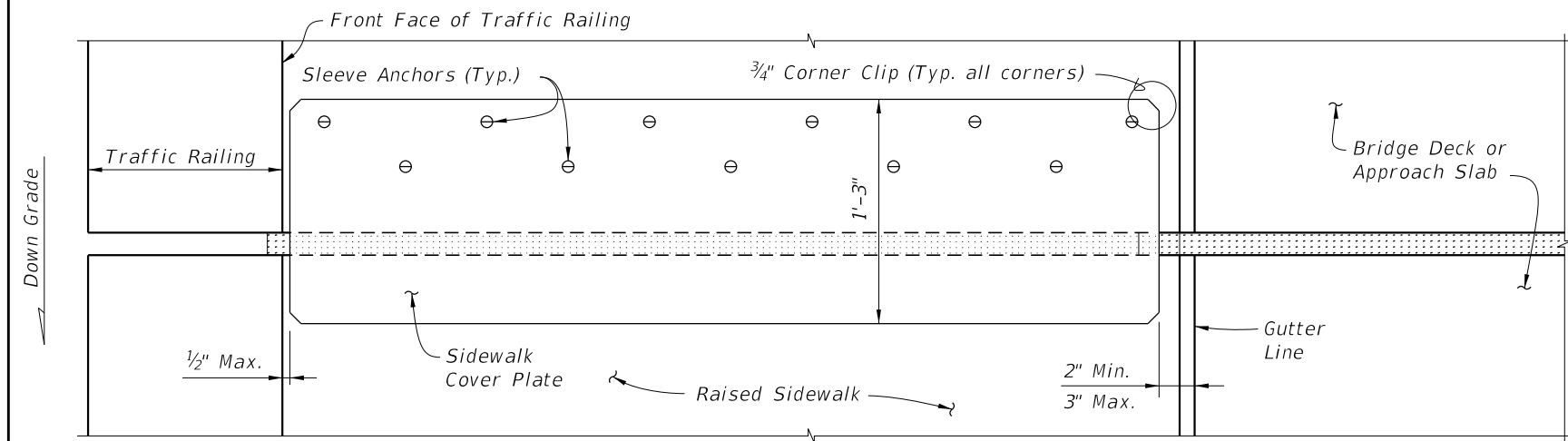

PARTIAL PLAN VIEW OF NON-SKEWED JOINTS

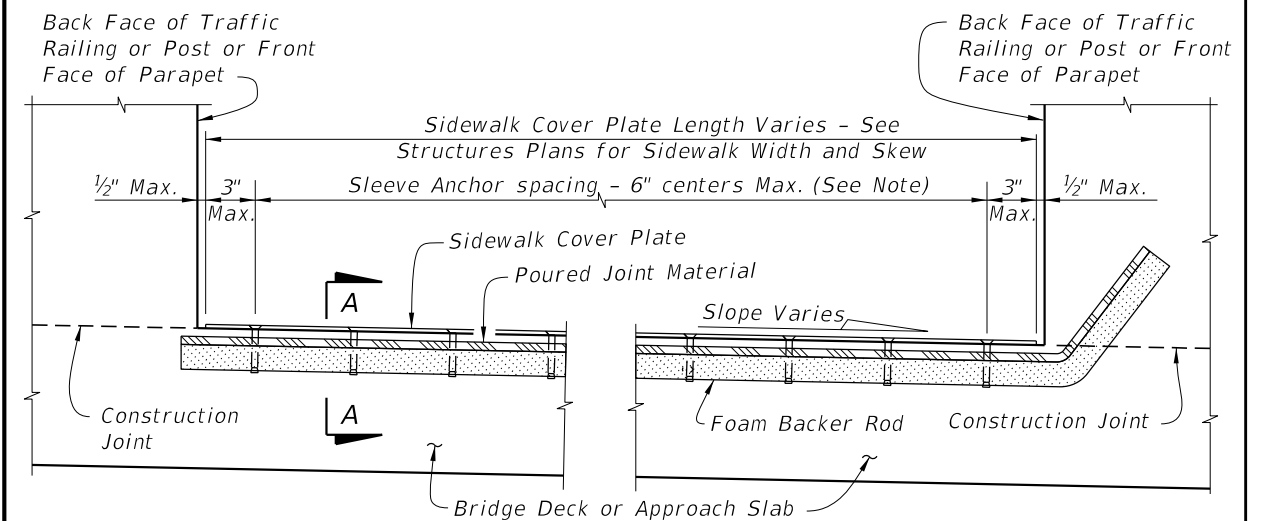

PARTIAL SECTION ALONG Q JOINT

FLUSH SIDEWALK DETAIL

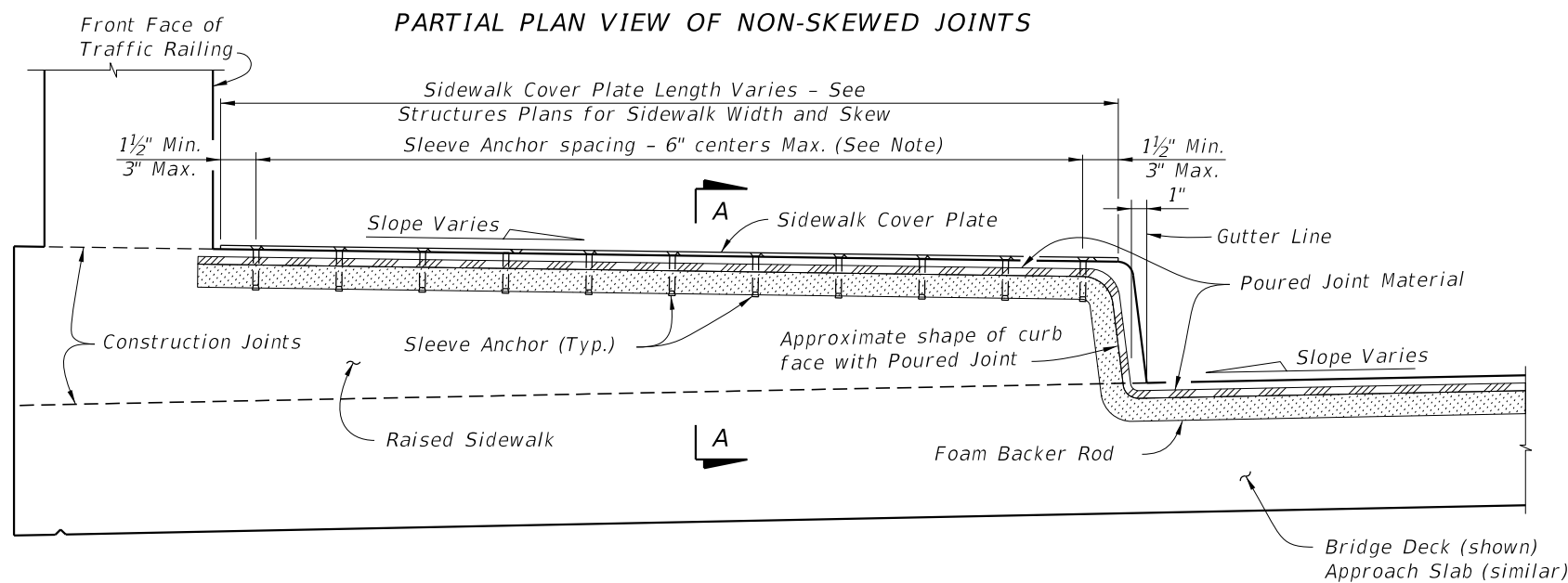

PARTIAL SECTION ALONG Q JOINT

RAISED SIDEWALK DETAIL

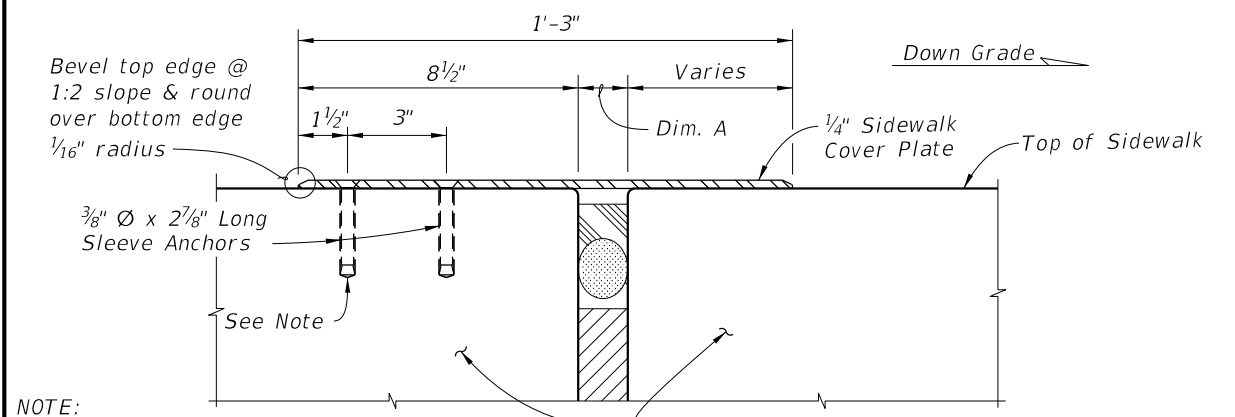

NOTE: Sleeve Anchors are required at the two outside corners of the Sidewalk Cover Plate. Space Sleeve Anchors uniformly between the corner anchors.

SECTION A-A

10/6/2025 2:55:09 PM

LAST REVISION 07/01/13	DESCRIPTION:
---------------------------	--------------