

ELEVATION

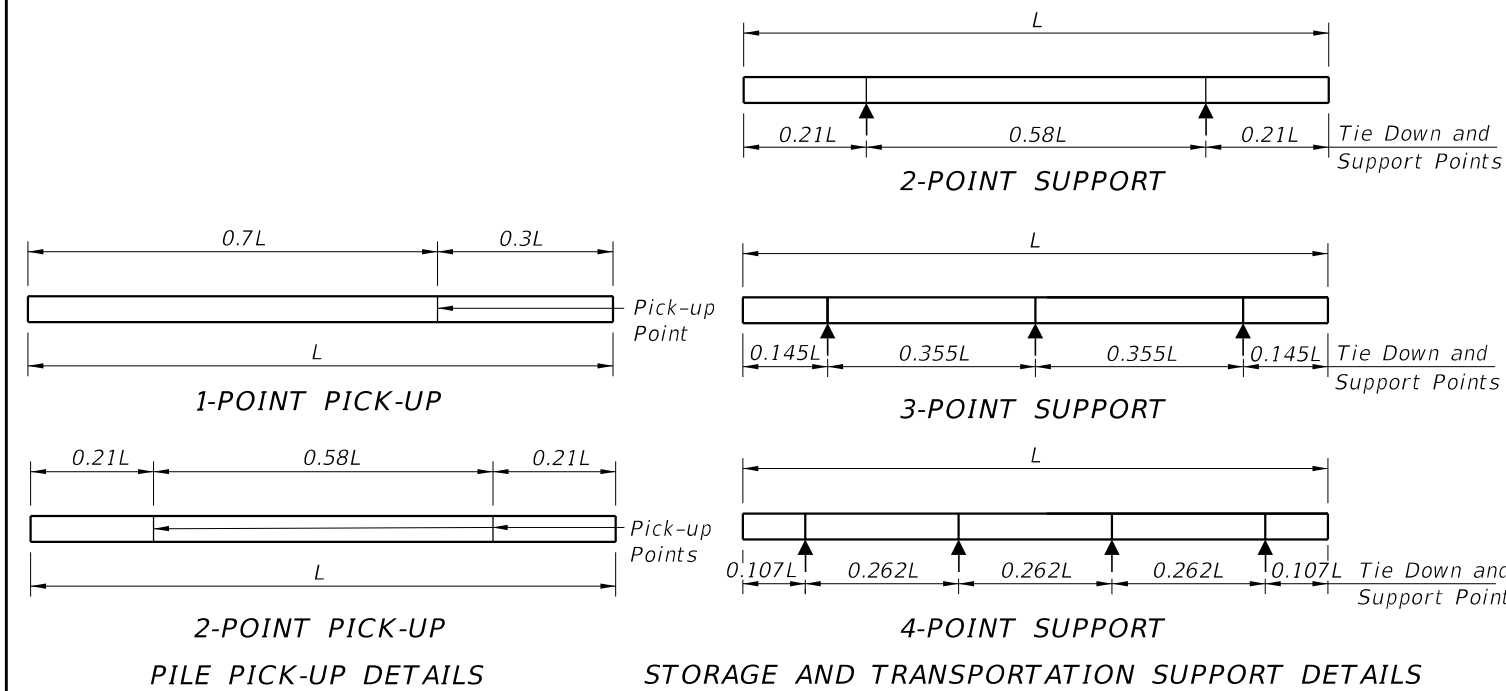
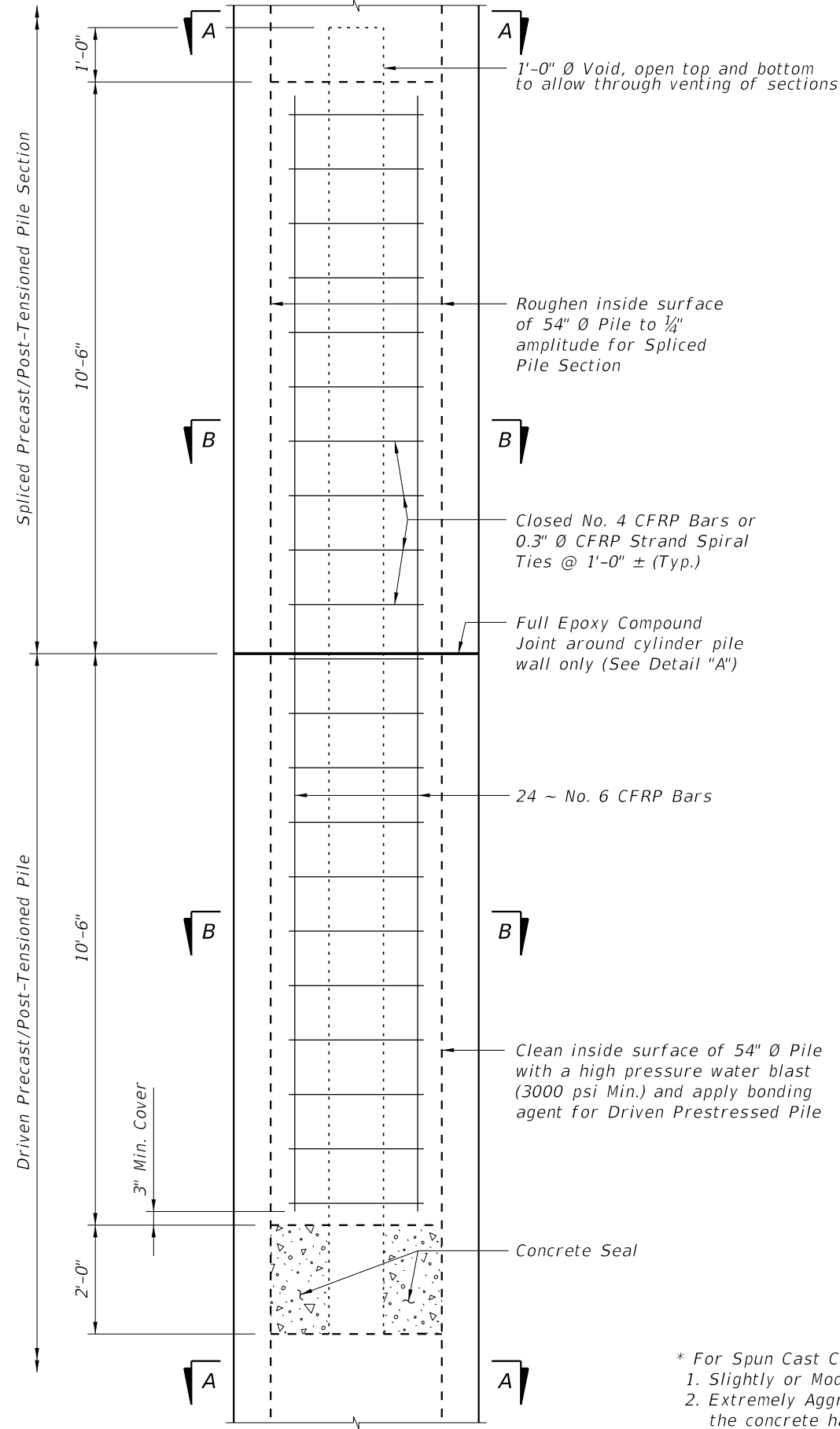

TABLE OF MAXIMUM PILE PICK-UP AND SUPPORT LENGTHS		
Maximum Pile Length (Feet)	Required Storage and Transportation Detail	Pick-Up Detail
119	2, 3, or 4 point	1 Point
170	2, 3, or 4 point	2 Point

NOTES

- Work this Index with the Pile Data Table in the Structures Plans.
- Concrete:
 - Piles: Class V
 - Splice: Class IV
 - See "GENERAL NOTES" in Structures Plans for locations where the use of Highly Reactive Pozzolans is required for options using stainless steel strand and reinforcing.
- Concrete Strength at time of application of the prestressing force:
 - Piles: 6,000 psi minimum.
- Reinforcing:
 - Bars:
 - Stainless Steel: Meet the requirements of Specification Section 931 for Type 304, Grade 75.
 - Carbon FRP: Meet the requirements of Specification Section 932.
 - Prestressing Strands:
 - Stainless Steel: Seven-wire HSSS, UNS S32205 (Type 2205) or UNS S31803 strand, meeting the requirements of Specification Section 933.
 - Carbon FRP: Meet the requirements of Specification Section 933.
 - Spiral Ties:
 - One half turn is required for carbon steel spiral splice.
 - One full turn is required at the pile head and tip.
- Pile Splices:
 - Epoxy: Type AB Epoxy Compound or Mortar must meet the requirements of Specification Section 926.
 - Use a Type AB Epoxy Bonding Compound or Epoxy Mortar, as recommended by the Manufacturer, to form the joint between pile sections.
 - Use a Type AB Epoxy Bonding Compound as a bonding agent on internal pile surfaces.
 - Driving: Resume pile driving after splice concrete reaches a minimum strength of 5,500 psi.
- Mark piles at the pick-up points to indicate the proper points for attaching handling lines.

10/6/2025 2:52:50 PM



DRIVABLE UNFORESEEN FIELD SPLICE DETAIL
(Cast-In-Place Plug)

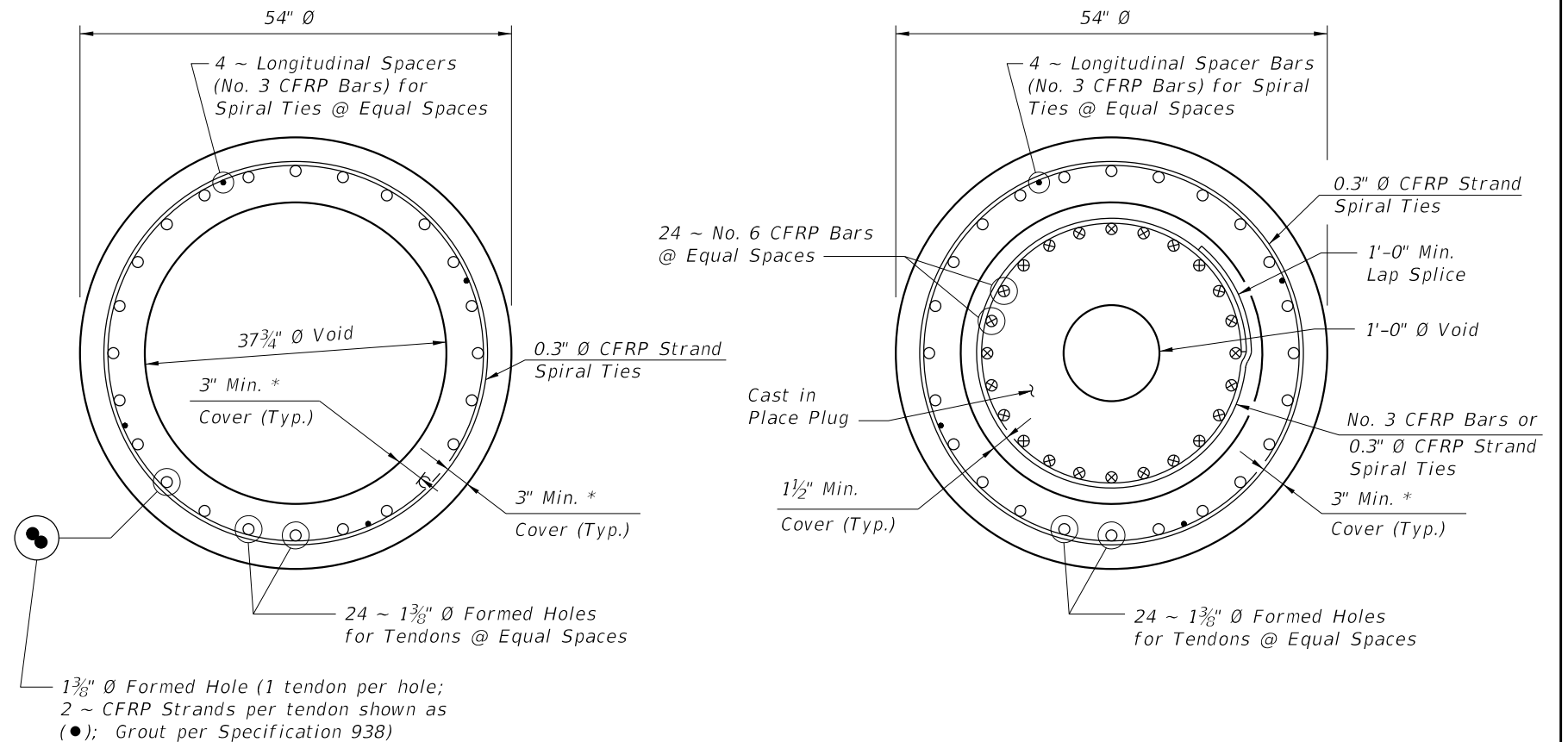

SECTION A-A

SECTION B-B

ALTERNATE STRAND PATTERNS

- 48 ~ 0.5" Ø, Single-Strand, at 28 kips
- 48 ~ 0.6" Ø, 7-Strand, at 29 kips

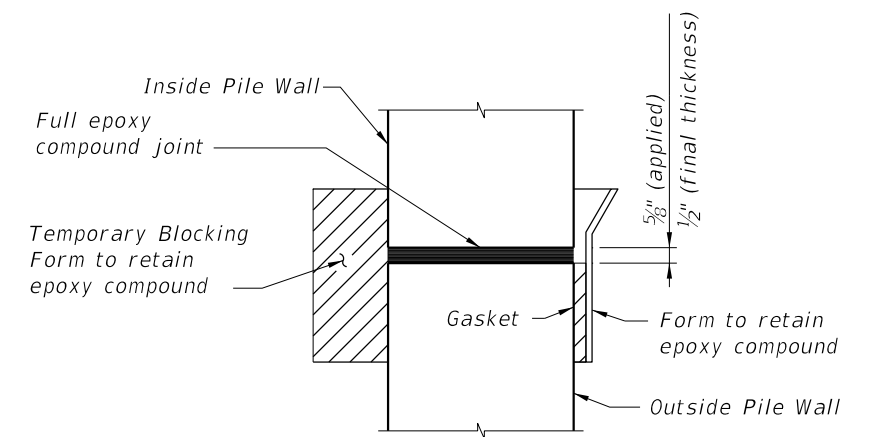

DETAIL "A"

* For Spun Cast Cylinder Piles, the following requirements for concrete cover apply:
 1. Slightly or Moderately Aggressive Environments: The concrete cover may be reduced to 2 inches.
 2. Extremely Aggressive Environments: The concrete cover may be reduced to 2 inches as long as the concrete has a documented chloride ion penetration apparent diffusion coefficient with a mean value of 0.005 in² per year or less; otherwise, a 3-inch concrete cover is required.

10/16/2025 2:52:56 PM

CFRP POST-TENSIONED PILE DETAILS

LAST REVISION 01/01/16	REVISION	DESCRIPTION:		FY 2026-27 STANDARD PLANS	54" PRECAST/POST-TENSIONED CFRP & SS CONCRETE CYLINDER PILE	INDEX 455-154	SHEET 2 of 3
---------------------------	----------	--------------	---	--------------------------------------	--	------------------	-----------------

10/6/2025 2:53:03 PM

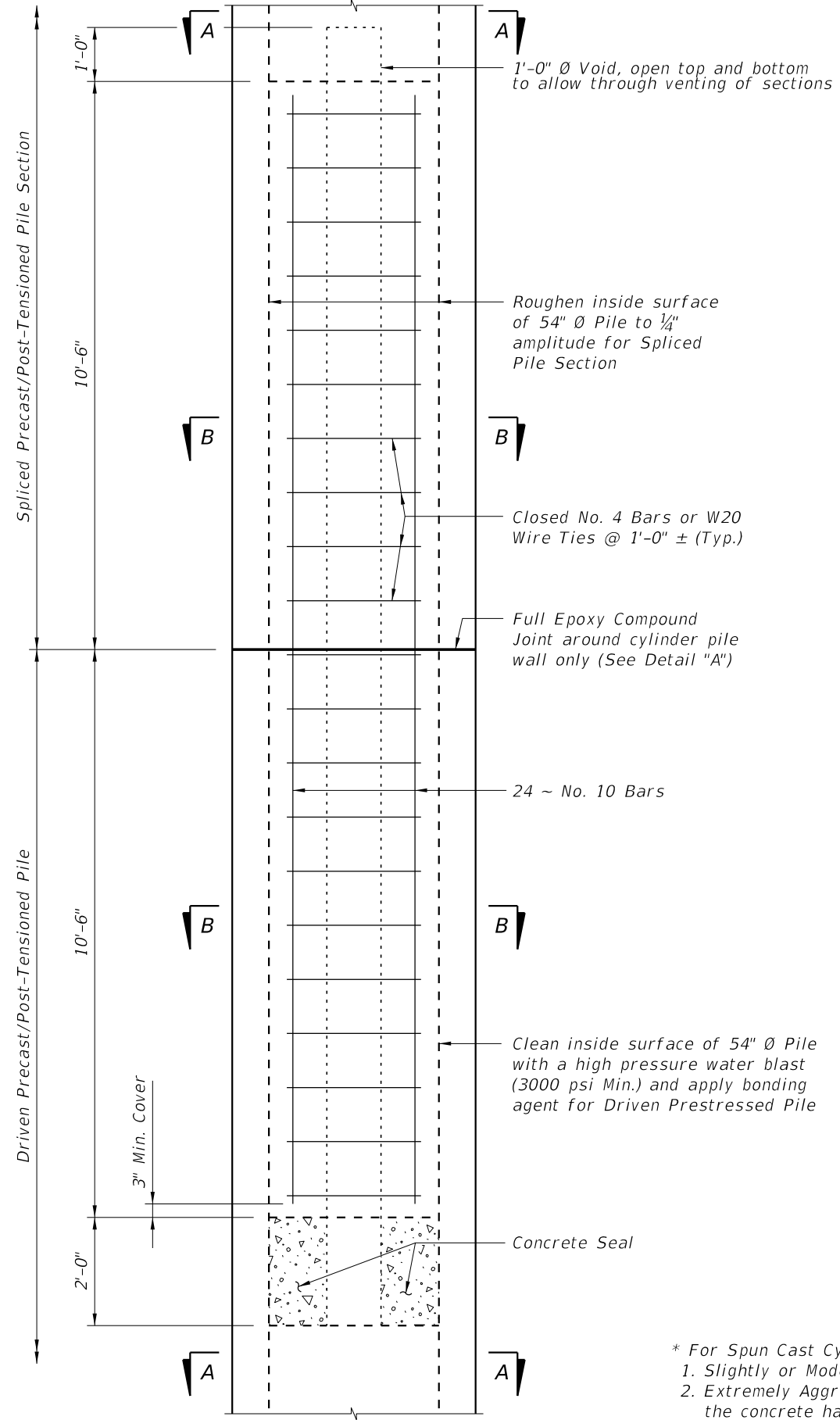

DRIVABLE UNFORESEEN FIELD SPLICE DETAIL
(Cast-In-Place Plug)

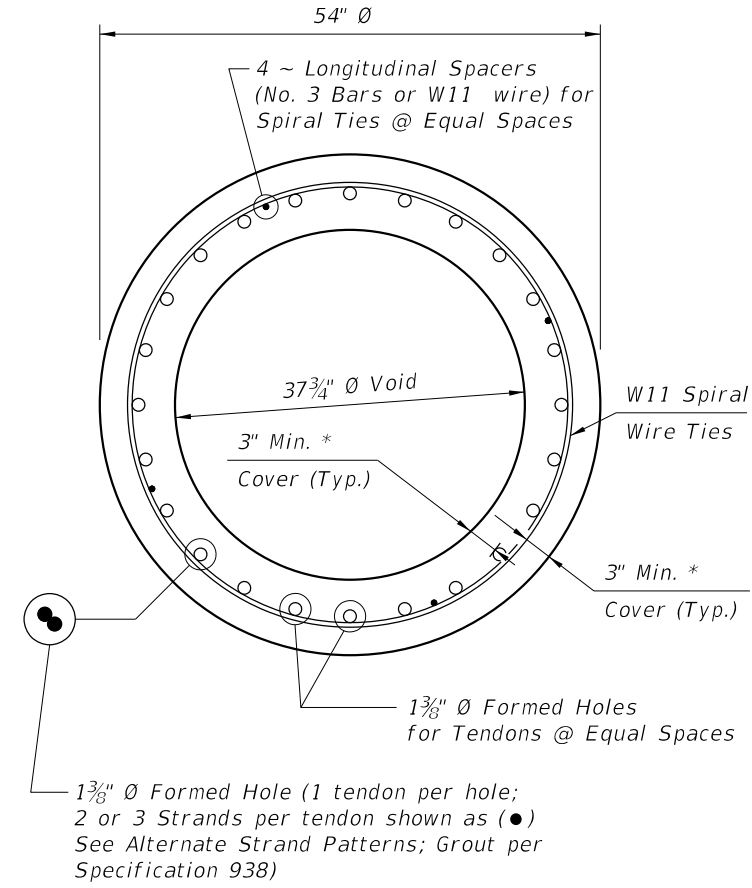

SECTION A-A

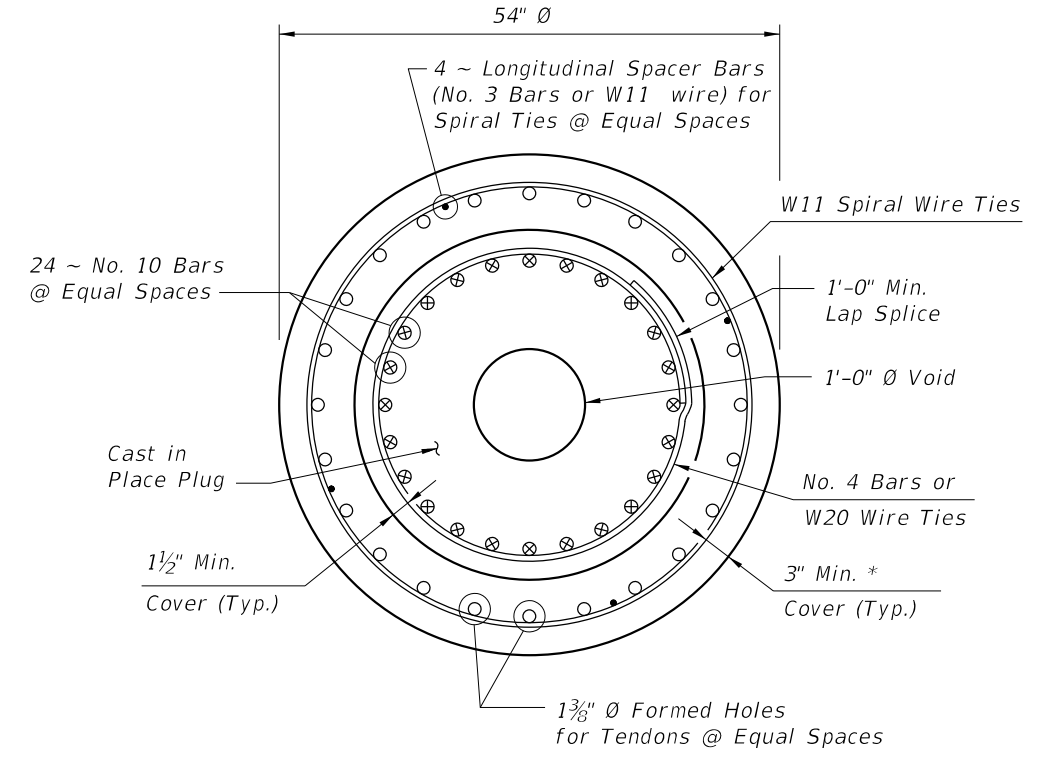

SECTION B-B

ALTERNATE STRAND PATTERNS

- 72 ~ 1/2" Ø, HSSS Strands, at 21 kips (24~3 strand tendons)
- 58 ~ 1/2" Ø, HSSS Strands, at 24 kips (29~2 strand tendons)
- 48 ~ 0.6" Ø, HSSS Strands, at 32 kips (24~2 strand tendons)

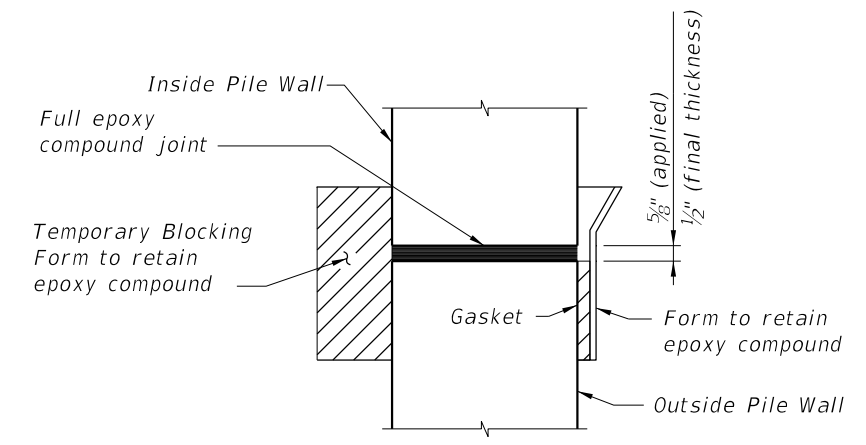

DETAIL "A"

* For Spun Cast Cylinder Piles, the following requirements for concrete cover apply:
 1. Slightly or Moderately Aggressive Environments: The concrete cover may be reduced to 2 inches.
 2. Extremely Aggressive Environments: The concrete cover may be reduced to 2 inches as long as the concrete has a documented chloride ion penetration apparent diffusion coefficient with a mean value of 0.005 in² per year or less; otherwise, a 3-inch concrete cover is required.

LAST REVISION 01/01/16	DESCRIPTION:		FY 2026-27 STANDARD PLANS	54" PRECAST/POST-TENSIONED CFRP & SS CONCRETE CYLINDER PILE	INDEX 455-154	SHEET 3 of 3
---------------------------	--------------	--	--------------------------------------	--	------------------	-----------------