

ELEVATION

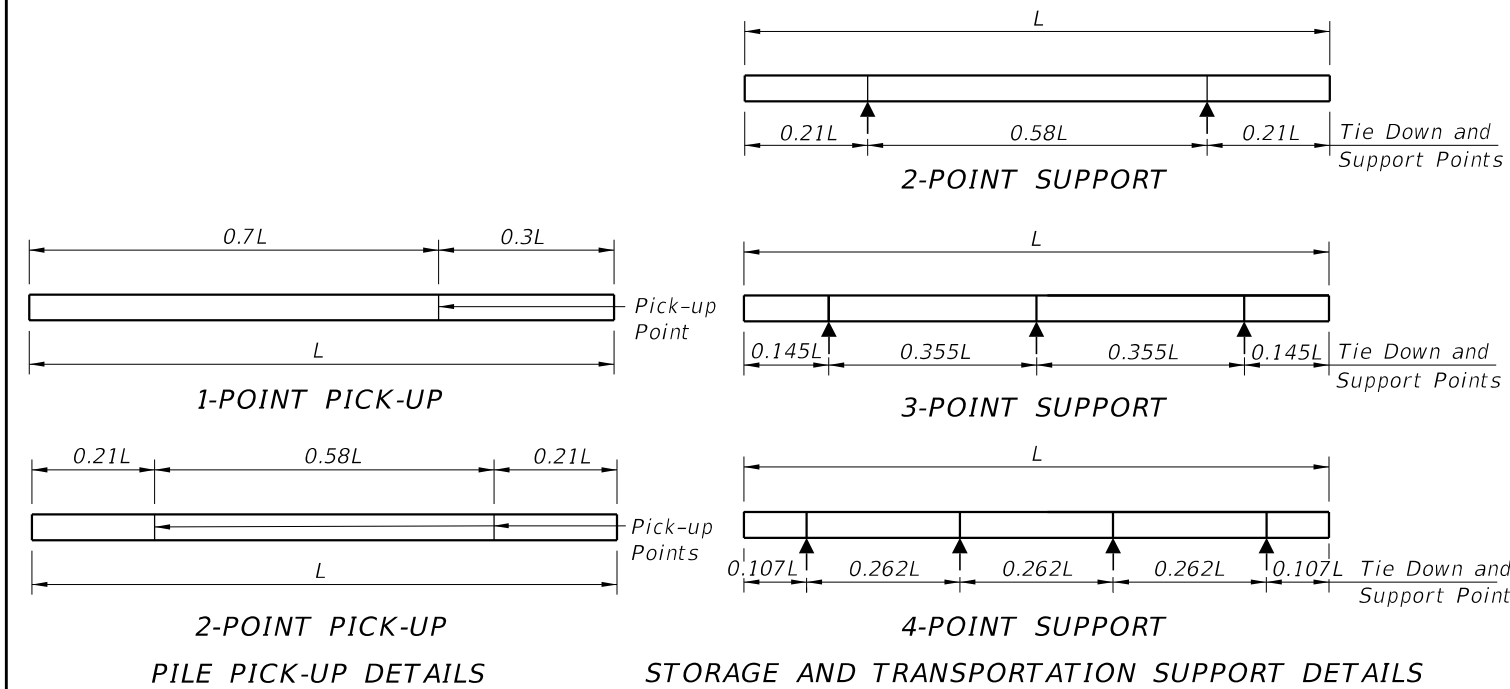

NOTES

1. Work this Index with the Pile Data Table in the Structures Plans.
2. Concrete:
 - A. Piles: Class V.
 - B. Splice: Class IV.
 - C. See "GENERAL NOTES" in Structures Plans for locations where the use of Highly Reactive Pozzolans is required.
3. Concrete Strength at time of prestress transfer:
 - A. Piles: 6,000 psi minimum.
4. Carbon-Steel Reinforcing:
 - A. Bars: Meet the requirements of Specification Section 415.
 - B. Prestressing Strands: Meet the requirements of Specification Section 933.
 - C. Tendons: Two seven-wire 1/2" dia. (Special) Grade 270, low-relaxation strands tensioned to 33.8 kips.
 - D. Protect all carbon-steel strands permanently exposed to the environment and not embedded under final conditions in accordance with Specification Section 450.
 - E. Spiral Ties:
 - a. One half turn is required for carbon-steel spiral splice.
 - b. One full turn is required at the pile head and tip.
5. Pile Splices:
 - A. Epoxy: Type AB Epoxy Compound or Mortar must meet the requirements of Specification Section 926.
 - a. Use a Type AB Epoxy Bonding Compound or Epoxy Mortar, as recommended by the Manufacturer, to form the joint between pile sections
 - b. Use a Type AB Epoxy Bonding Compound as a bonding agent on internal pile surfaces.
 - B. Driving: Resume pile driving after splice concrete reaches a minimum strength of 5,500 psi.
6. Mark piles at the pick-up points to indicate the proper points for attaching handling lines.

TABLE OF MAXIMUM PILE PICK-UP AND SUPPORT LENGTHS

Maximum Pile Length (Feet)	Required Storage and Transportation Detail	Pick-Up Detail
119	2, 3, or 4 point	1 Point
170	2, 3, or 4 point	2 Point

10/6/2025 2:48:22 PM

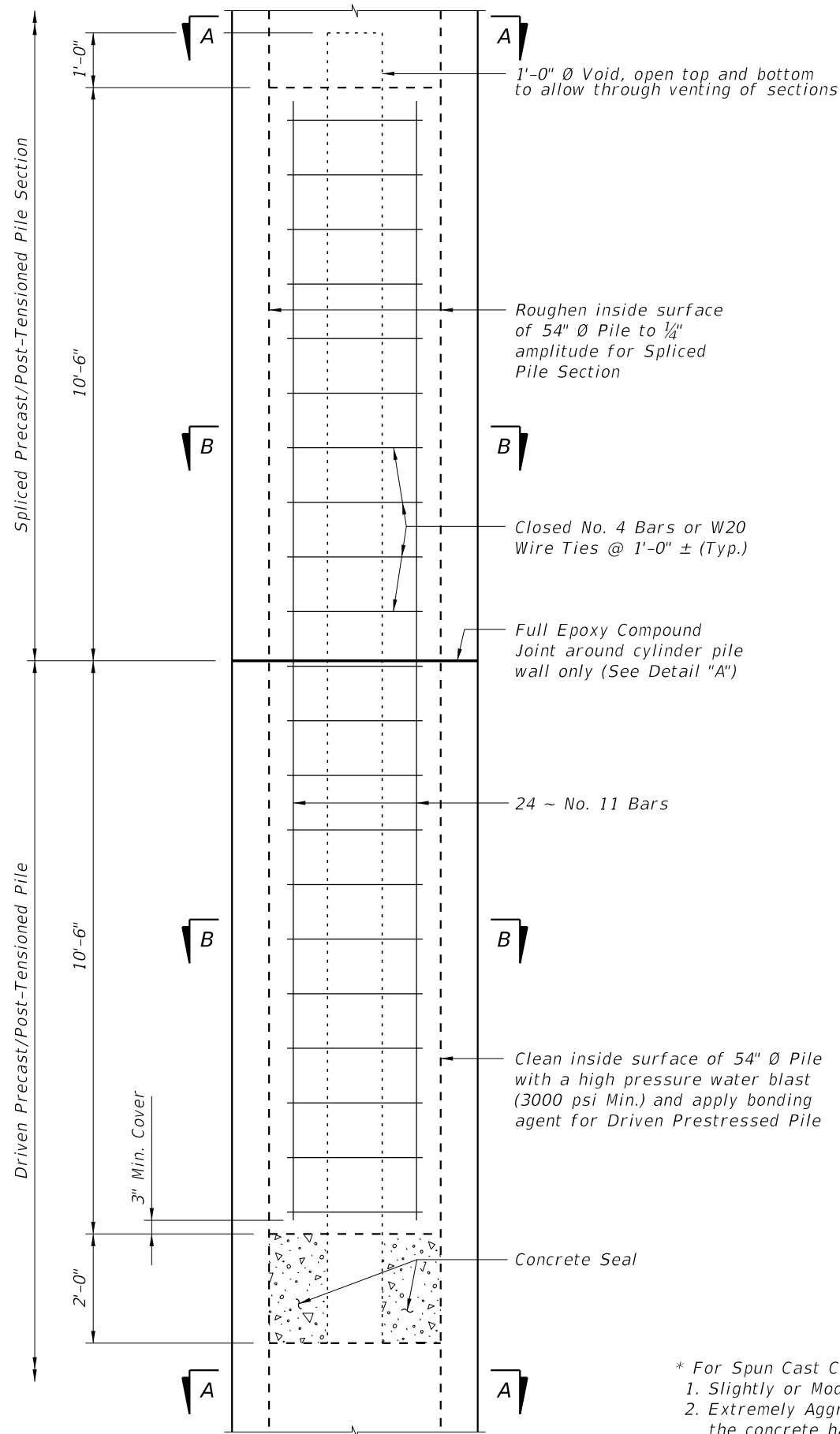

DRIVABLE UNFORESEEN FIELD SPLICE DETAIL
(Cast-In-Place Plug)

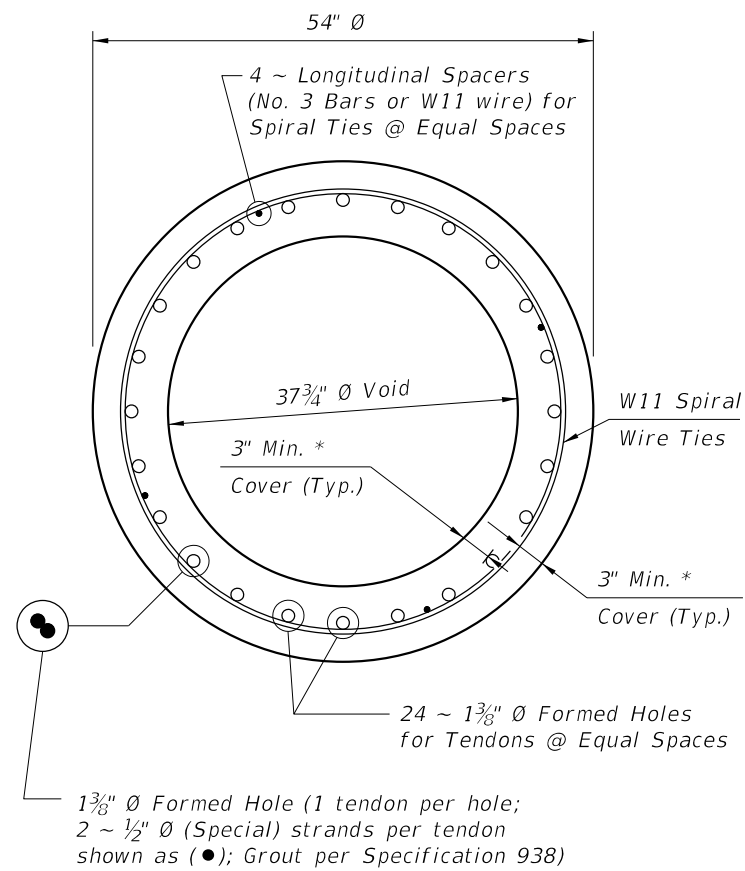

SECTION A-A

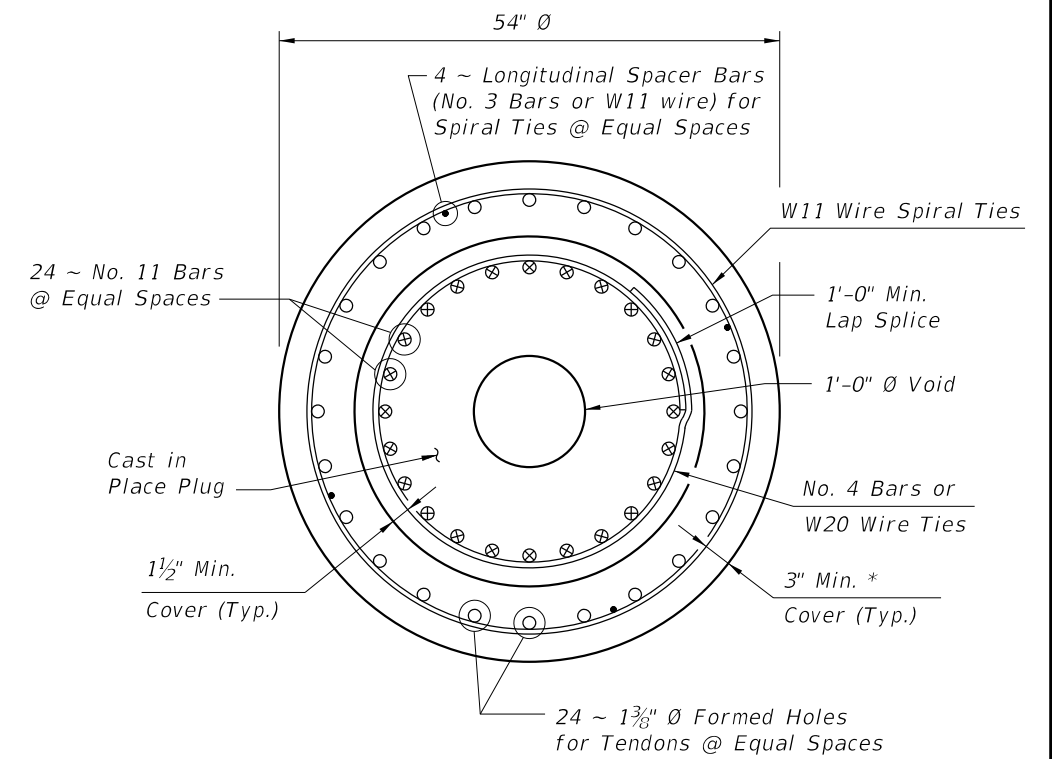

SECTION B-B

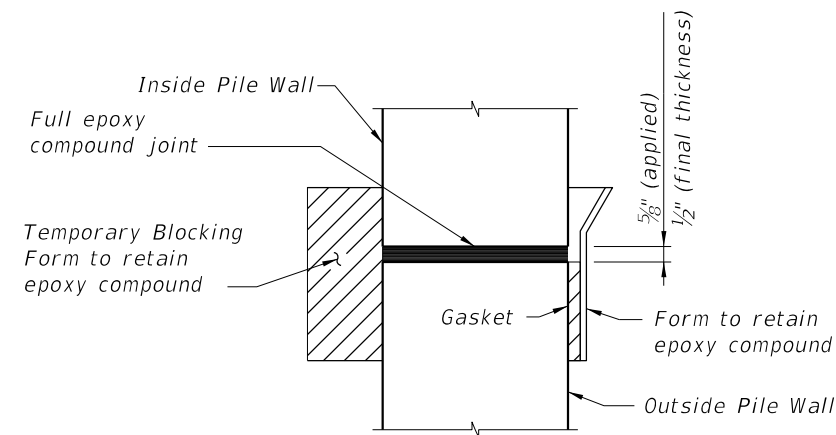

DETAIL "A"

* For Spun Cast Cylinder Piles, the following requirements for concrete cover apply:
 1. Slightly or Moderately Aggressive Environments: The concrete cover may be reduced to 2 inches.
 2. Extremely Aggressive Environments: The concrete cover may be reduced to 2 inches as long as the concrete has a documented chloride ion penetration apparent diffusion coefficient with a mean value of 0.005 in² per year or less; otherwise, a 3-inch concrete cover is required.

10/6/2025 2:48:29 PM

LAST REVISION 07/01/13	DESCRIPTION:	 FY 2026-27 STANDARD PLANS	54" PRECAST/POST-TENSIONED CONCRETE CYLINDER PILE	INDEX 455-054	SHEET 2 of 2
---------------------------	--------------	---	--	------------------	-----------------