

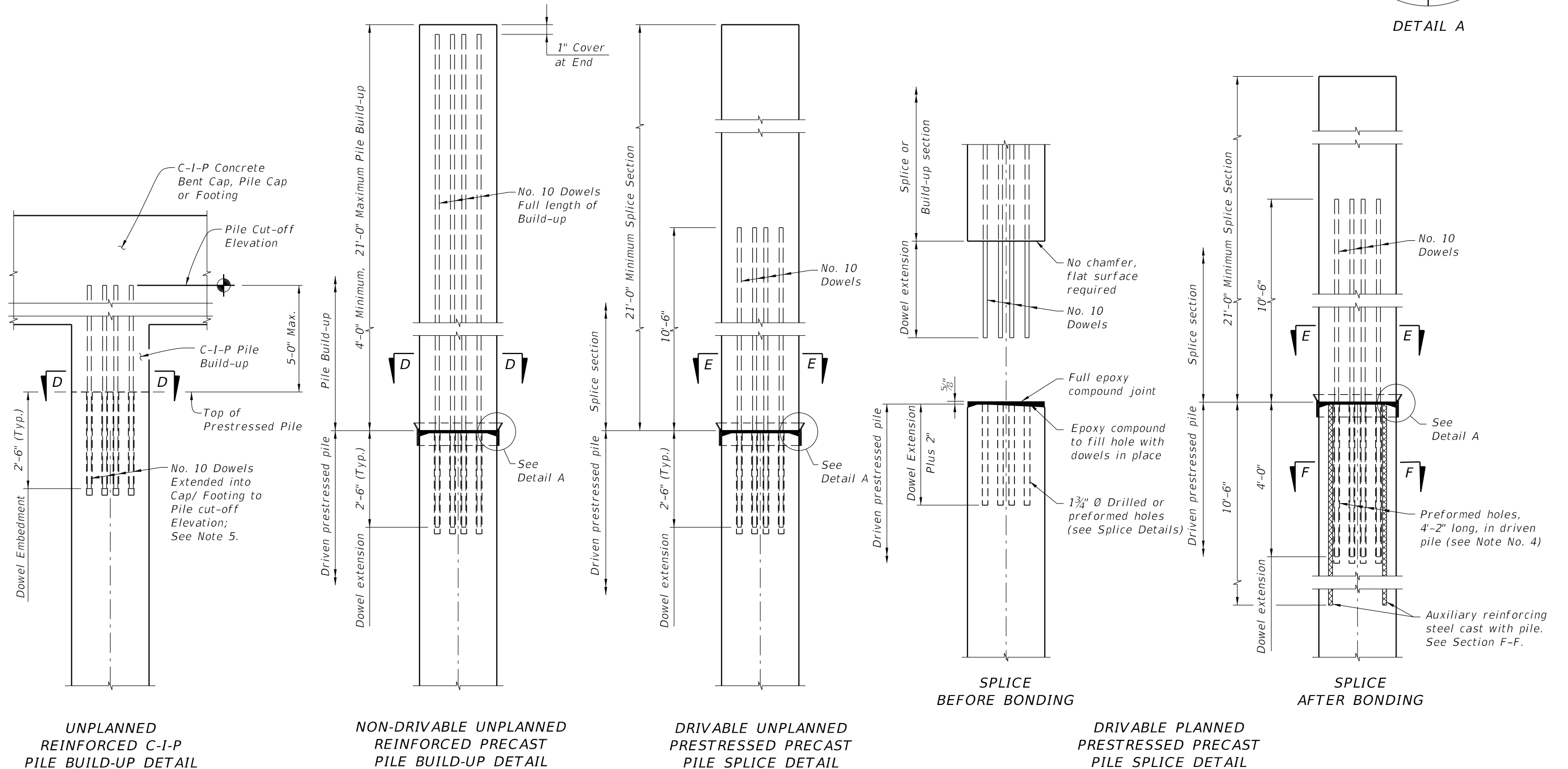

NOTES:

1. For Sections D-D, E-E, & F-F see Index 455-012 thru 455-030 for applicable concrete pile size and Pile Splice Reinforcement Details.
2. Prestressing strands, spiral ties and/or reinforcement are not shown for clarity.
3. When pile splices are necessary due to shipping and handling limitations, use the "Drivable Planned Prestressed Precast Splice Detail" or Mechanical Pile Splices on the Approved Products List (APL).
4. When preformed dowel holes are used, continue the 1" spiral tie pitch to 4'-0" below the head of the pile, See Index 455-018, 455-020 & 455-024. For preformed holes; use either removable preforming material or stay-in-place corrugated galvanized steel ducts meeting ASTM Specification A653, Coating Designation G90, 26 gauge. Use 2" diameter ducts with a minimum corrugation (rib) height of 0.12 in. fabricated with either welded or interlocked seams. Galvanizing of welded seams is not required.
5. For tension piles where top of Prestressed Pile is less than 3 feet below Pile Cut-off Elevation, extend No. 10 Dowels into cap beyond Pile Cut-off Elevation to achieve development as approved by the Engineer.

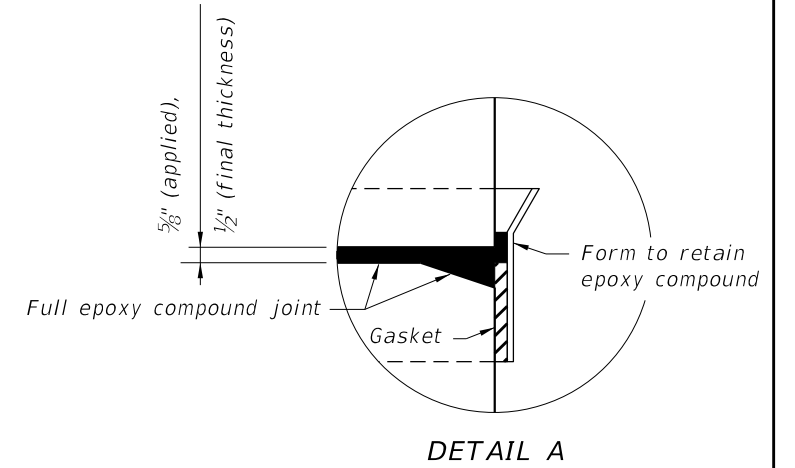

10/16/2025 2:45:49 PM

LAST REVISION 11/01/22	DESCRIPTION:		FY 2026-27 STANDARD PLANS	SQUARE PRESTRESSED CONCRETE PILE SPLICES	INDEX 455-002	SHEET 1 of 1
---------------------------	--------------	---	------------------------------	--	------------------	-----------------