

**BUILD-UP DIAGRAM FOR TANGENT SPANS
(ALONG C FLANGE) (CASE 1)**

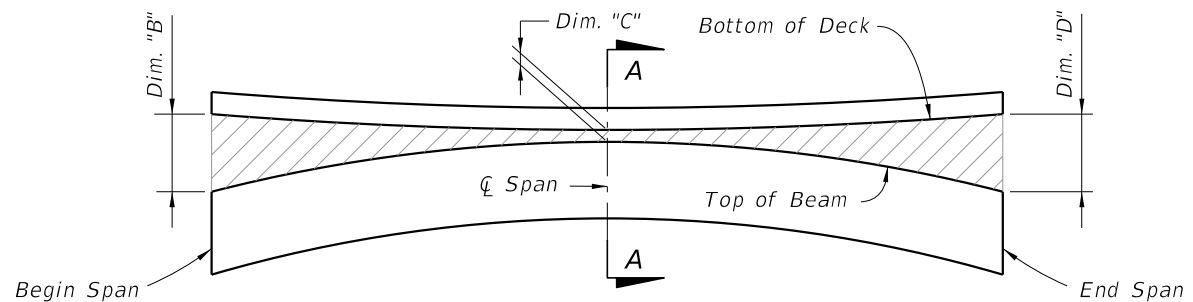

**BUILD-UP DIAGRAM FOR SAG VERTICAL CURVE & HORIZONTAL CURVE SPANS
(ALONG C FLANGE) (CASE 2)**

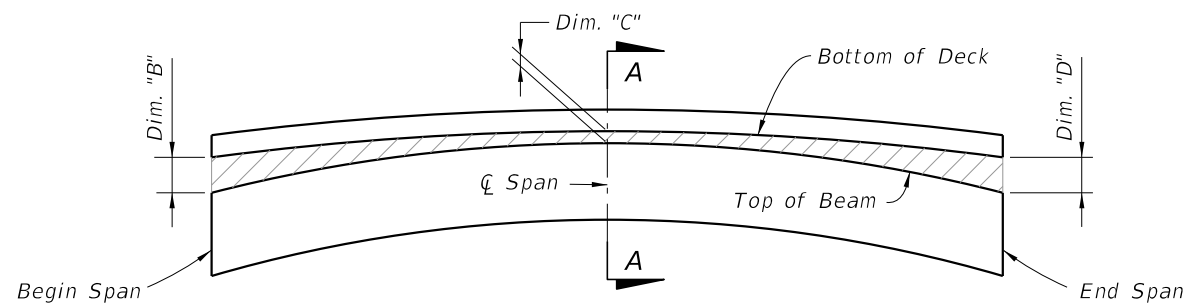

**BUILD-UP DIAGRAM FOR CREST VERTICAL CURVE SPANS
- CONTROL AT C SPAN
(ALONG C FLANGE) (CASE 3)**

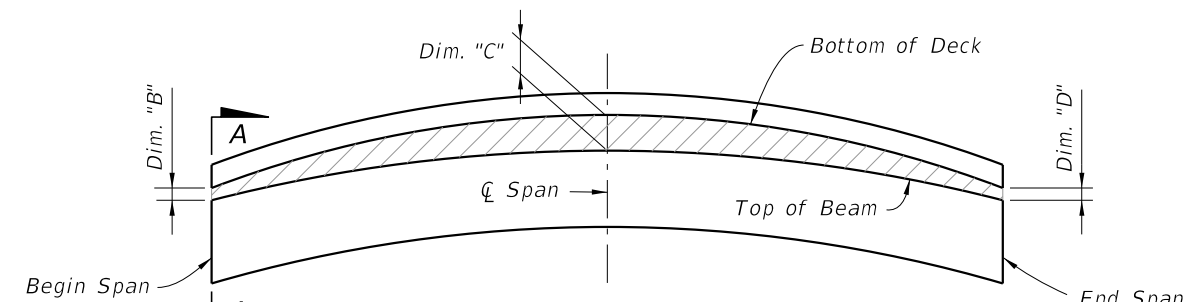

**BUILD-UP DIAGRAM FOR CREST VERTICAL CURVE SPANS
- CONTROL AT BEGIN OR END SPAN
(ALONG C FLANGE) (CASE 4)**

BEAM CAMBER AND BUILD-UP NOTES:

The build-up values given in the Data Table* are based on theoretical beam cambers. The Contractor shall monitor beam cambers for the purpose of predicting camber values at the time of the deck pour. If the predicted cambers based on field measurements differ more than +/- 1/2" from the theoretical "Net Beam Camber @ 120 Days" shown in the Data Table*, obtain approval from the Engineer to modify the build-up dimensions as required. When the measured beam cambers create a conflict with the bottom mat of deck steel, notify the Engineer a minimum of 21 days prior to casting.

Dim. "A" includes the weight of the Stay-In-Place Formwork.

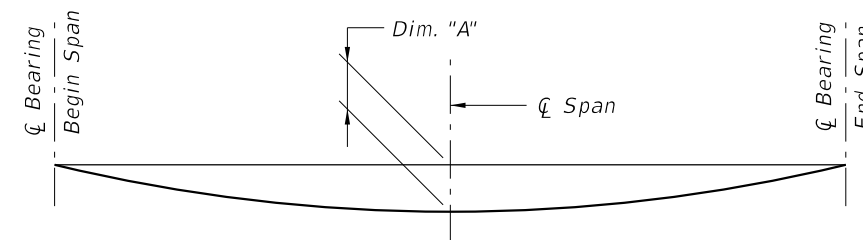

**DEAD LOAD DEFLECTION DIAGRAM
(ALONG C BEAM)**

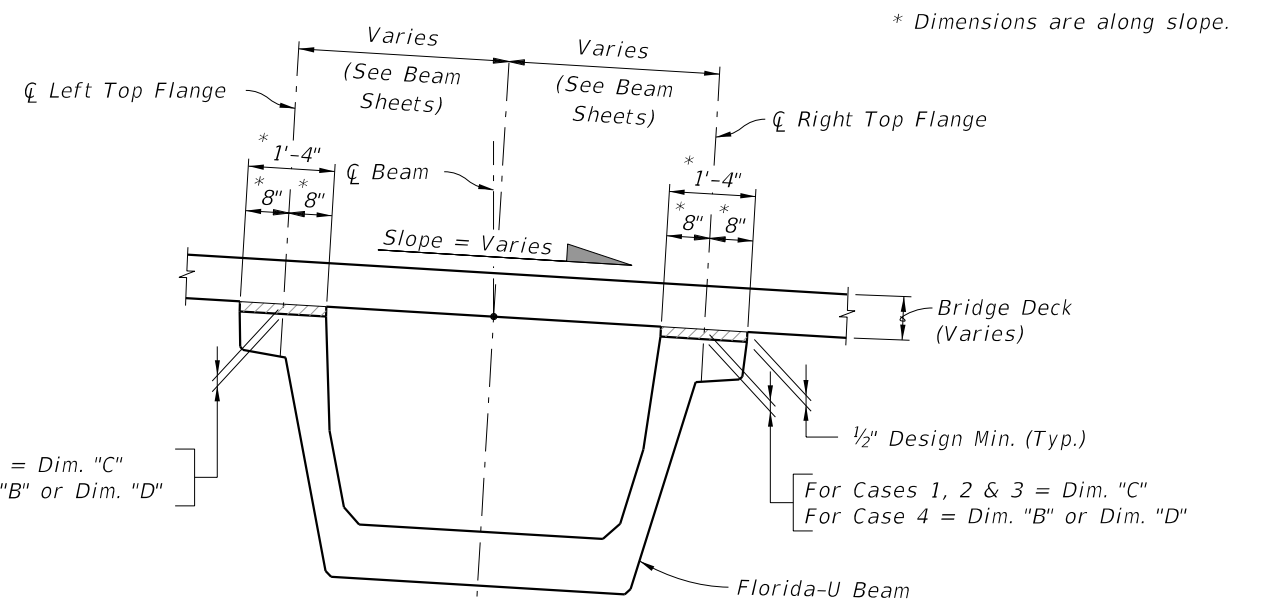

For Cases 1, 2 & 3 = Dim. "C"
For Case 4 = Dim. "B" or Dim. "D"

For Cases 1, 2 & 3 = Dim. "C"
For Case 4 = Dim. "B" or Dim. "D"

* NOTE:
Work this Index with the Build-up and Deflection
Data Table for Florida-U Beams in Structures Plans.

**SECTION A-A
BUILD-UP OVER BEAMS
(LOOKING AHEAD STATION)**

10/6/2025 2:42:10 PM

LAST REVISION 07/01/15	REVISION	DESCRIPTION:		FY 2026-27 STANDARD PLANS	FLORIDA-U BEAMS - BUILD-UP & DEFLECTION DATA	INDEX 450-299	SHEET 1 of 1
---------------------------	----------	--------------	---	------------------------------	---	------------------	-----------------