

LAST REVISION 11/01/16	DESCRIPTION:	 FY 2026-27 STANDARD PLANS	FLORIDA-U 72 BEAM - STANDARD DETAILS	INDEX 450-272	SHEET 1 of 3
---------------------------	--------------	--	--------------------------------------	------------------	-----------------

10/6/2025 2:41:36 PM

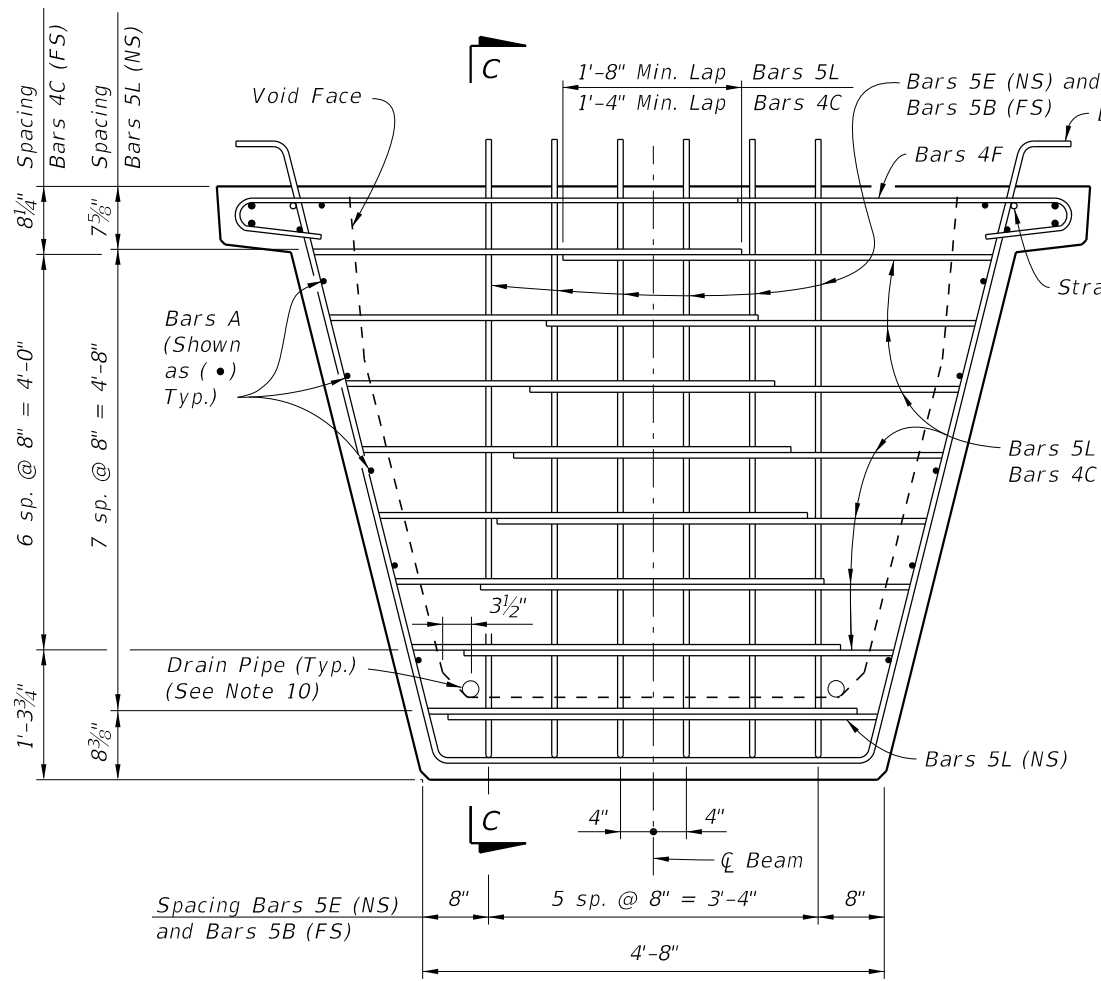

END VIEW AT END DIAPHRAGM

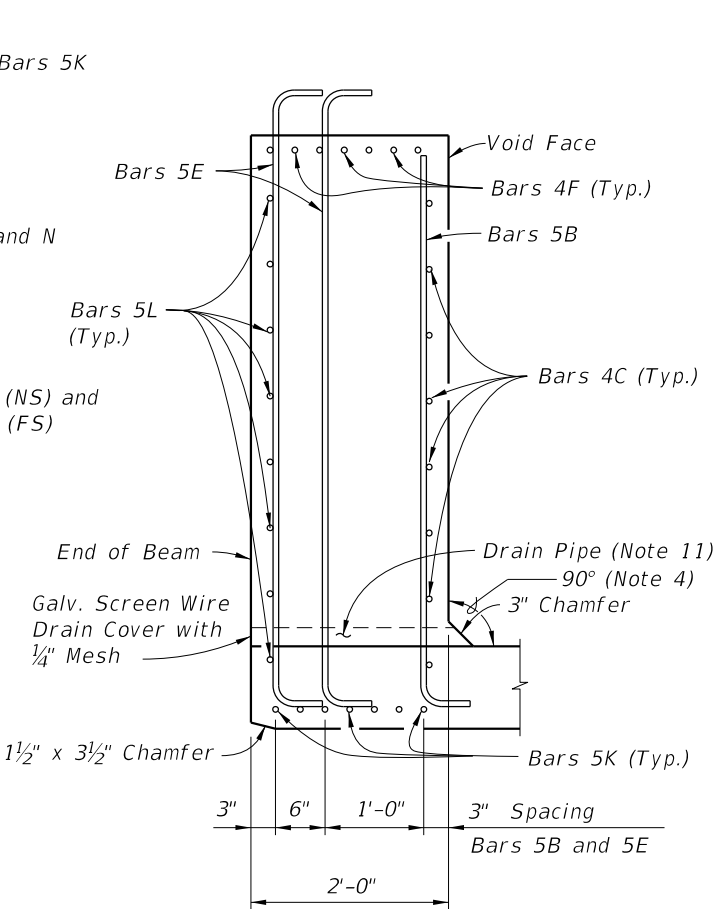

SECTION C-C

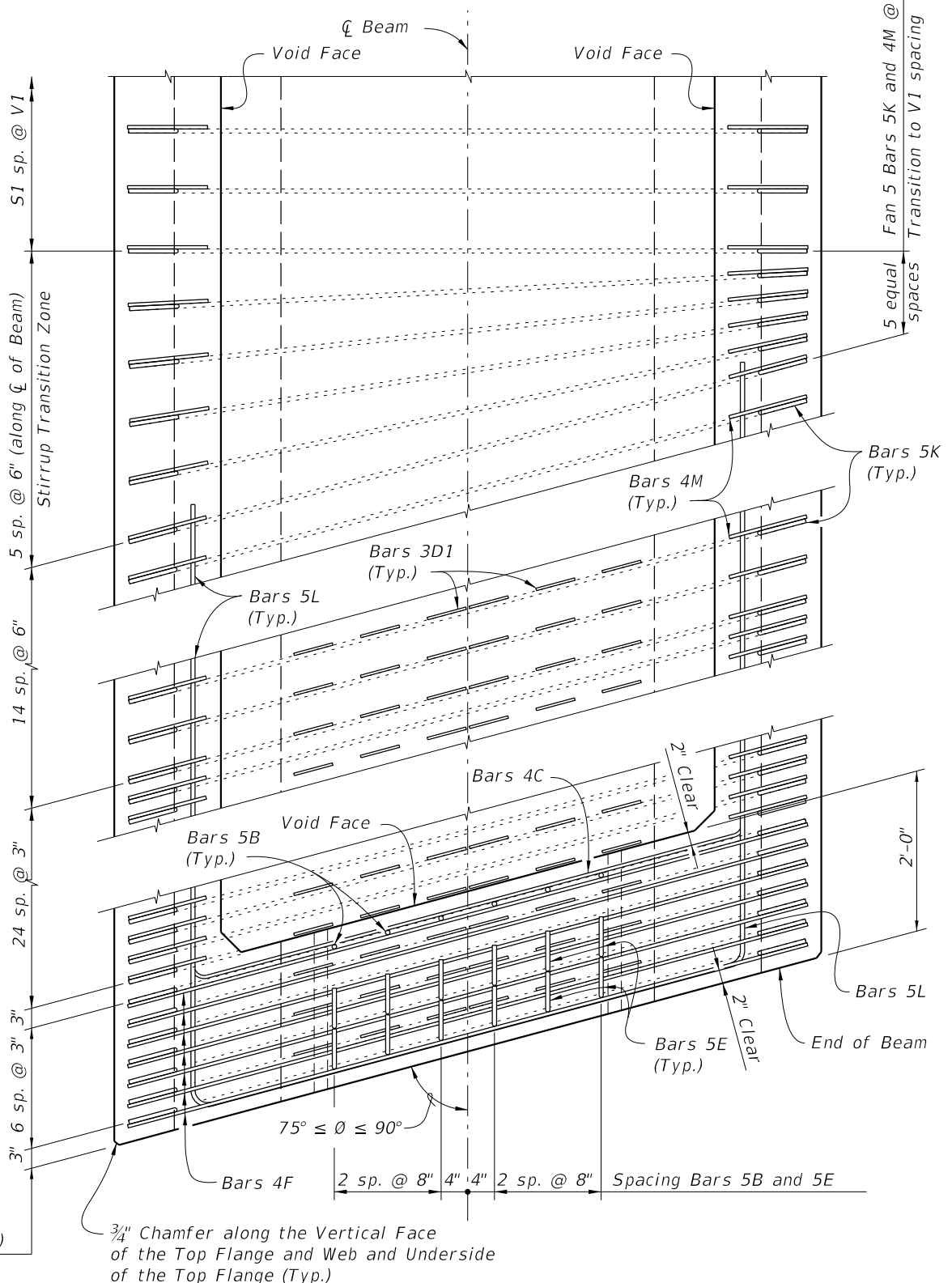

TOP VIEW OF SKEWED END DIAPHRAGM AND STIRRUP TRANSITION ZONE (Bars 3D2 Not Shown For Clarity)

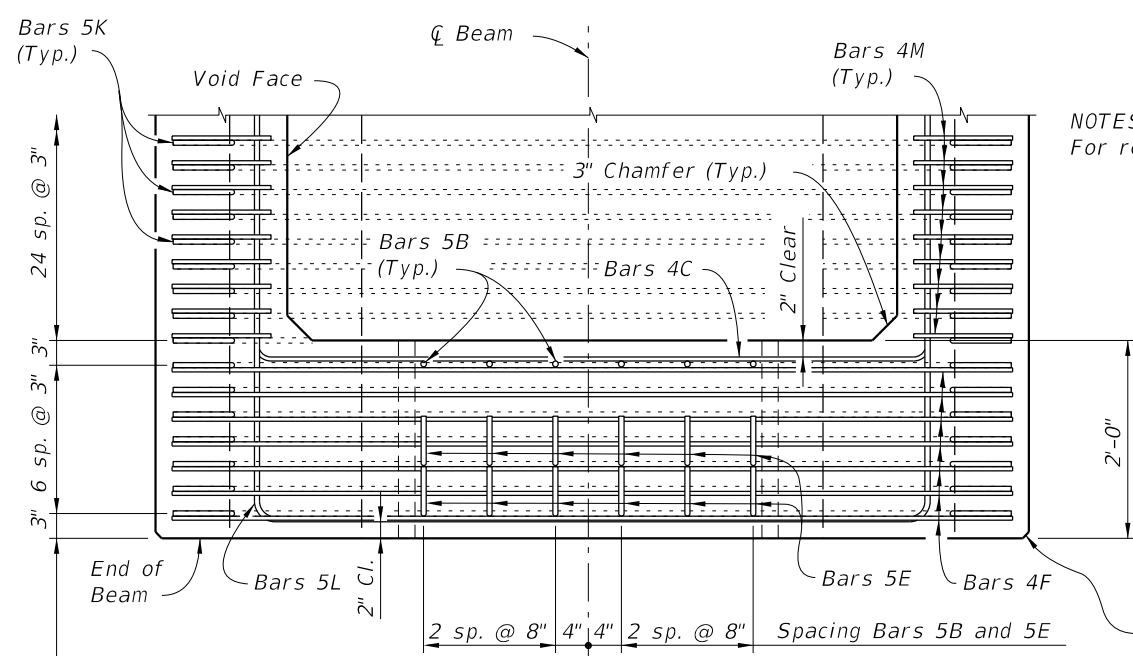

TOP VIEW OF END DIAPHRAGM (Bars 3D1 And 3D2 Not Shown For Clarity)

NOTES:  
For referenced notes see Index 450-210.

3/4" Chamfer along the Vertical Face of the Top Flange and Web and Underside of the Top Flange (Typ.)

Spacing Bars 5K (Along Ø of Beam)  
(Bars 4F and 4M are Paired with Bars 5K as shown)

10/6/2025 2:41:42 PM

LAST REVISION 11/01/16	DESCRIPTION:		FY 2026-27 STANDARD PLANS	FLORIDA-U 72 BEAM - STANDARD DETAILS	INDEX	SHEET
					450-272	2 of 3

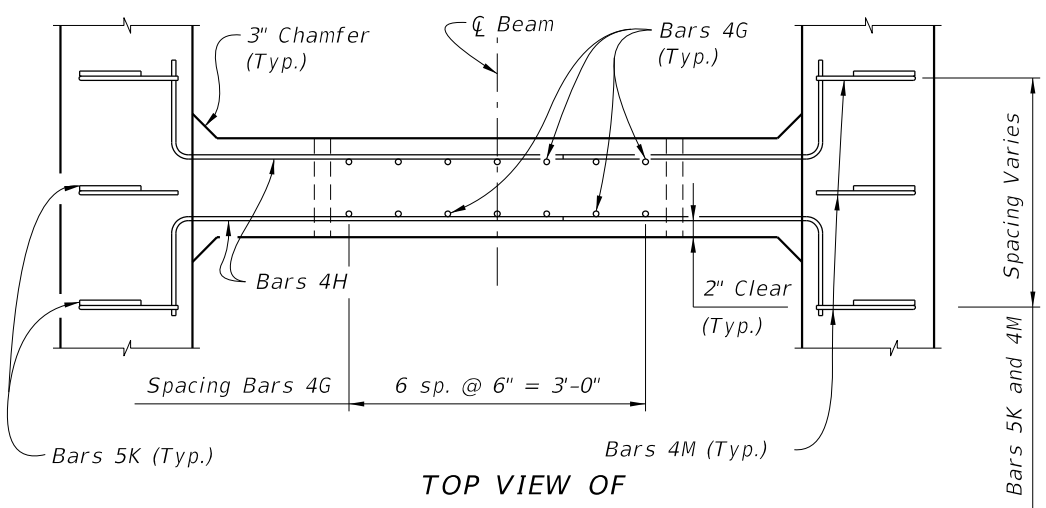

TOP VIEW OF INTERMEDIATE DIAPHRAGM

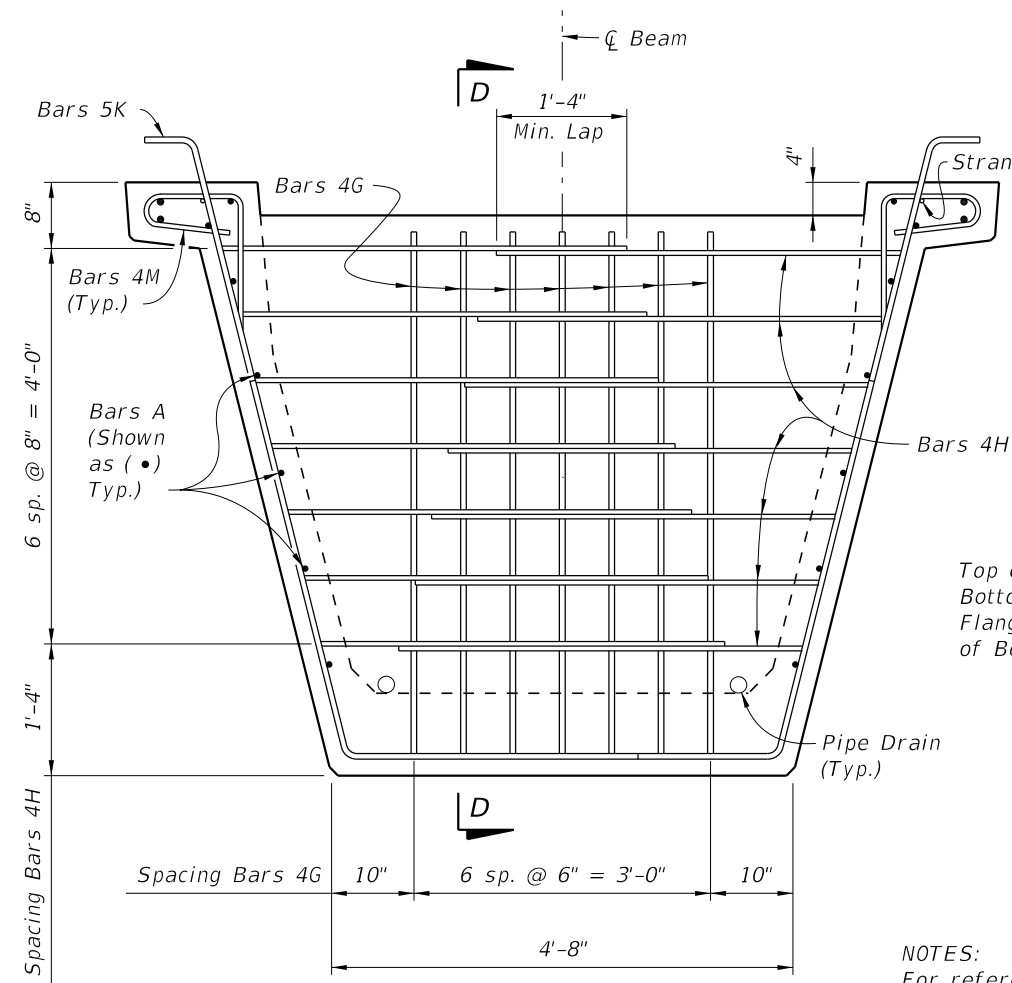

SECTION AT INTERMEDIATE DIAPHRAGM

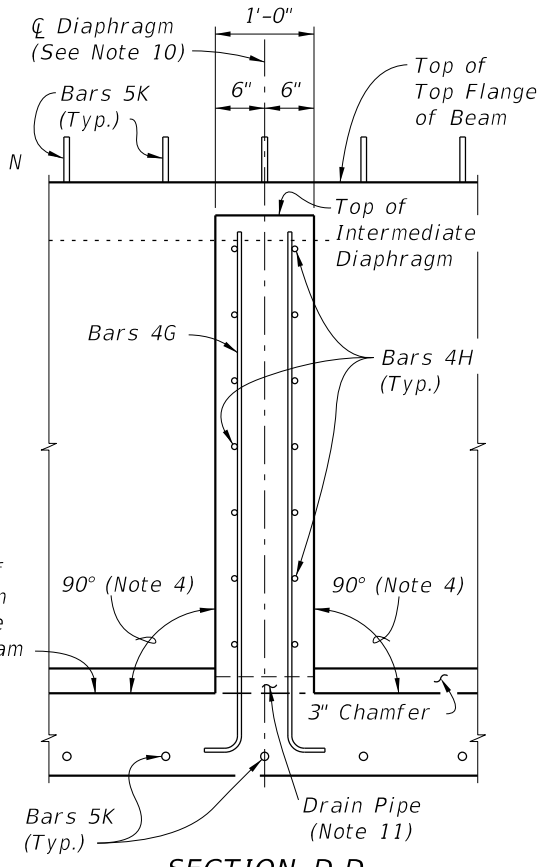

SECTION D-D

NOTES:  
For referenced notes see Index 450-210.

CONVENTIONAL REINFORCING STEEL BENDING DIAGRAMS

**BILL OF REINFORCING STEEL FOR ONE BEAM ONLY**

MARK	SIZE	NO. REQD.	LENGTH
A1	6	4	Dim. L - 4"
A2	4	14	Dim. L - 4"
B	5	12	6'-1"
C	4	28	5'-7"
D1	3	228	1'-6"
D2	3	38	4'-6"
E	5	24	7'-3"
F	4	28	6'-9"
G	4	See Table	6'-0"
H	4	See Table	5'-1"
K	5	See Table	10'-0"
L	5	32	19'-6"
M	4	See Table	3'-11"
N	$\frac{3}{8}$ " $\emptyset$ Strand	2	Dim. L - 3"

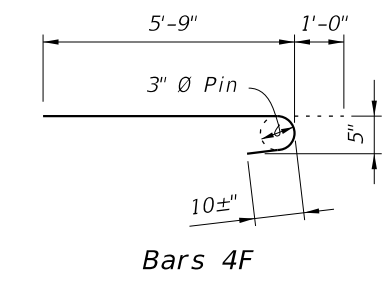
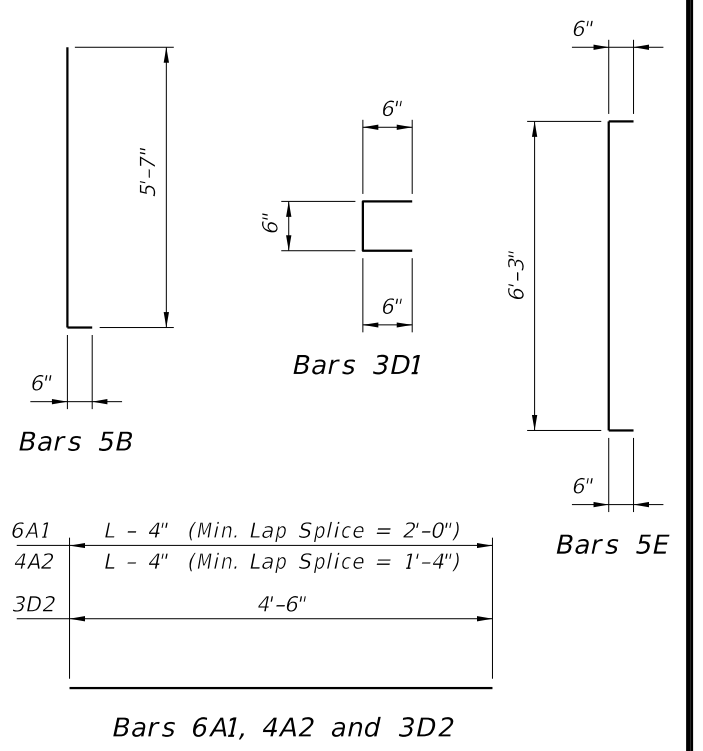

Bars 4F

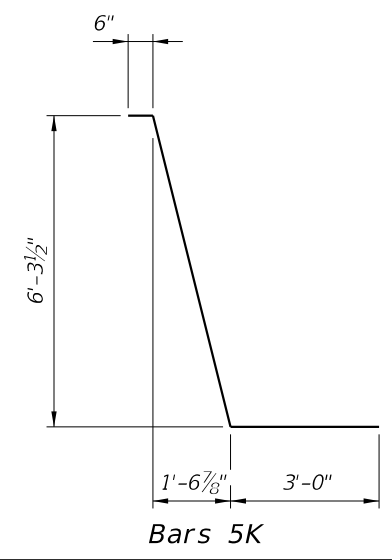

Bars 5K

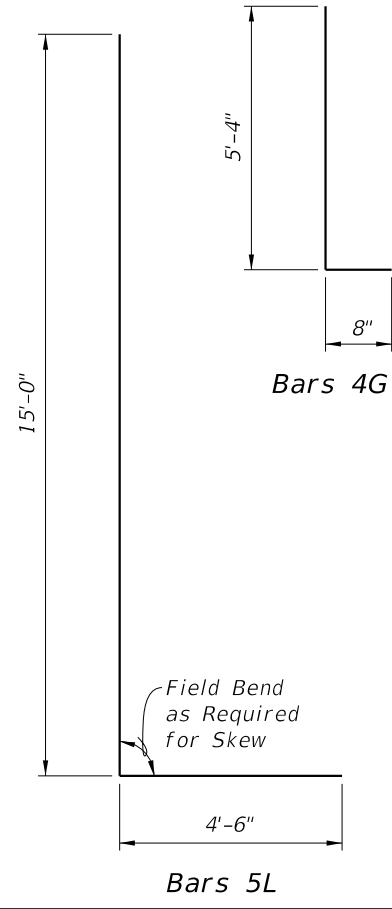

Bars 4G

Bars 5L

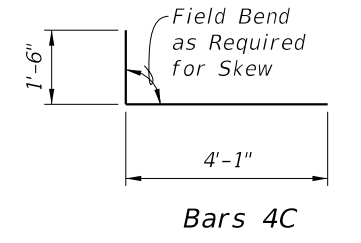

Bars 4C

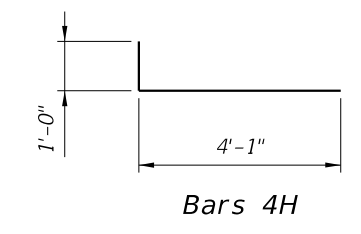

Bars 4H

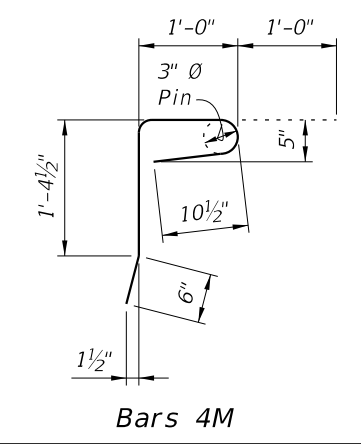

Bars 4M

10/6/2025 2:41:48 PM