

* These dimensions are measured perpendicular to the end of beam

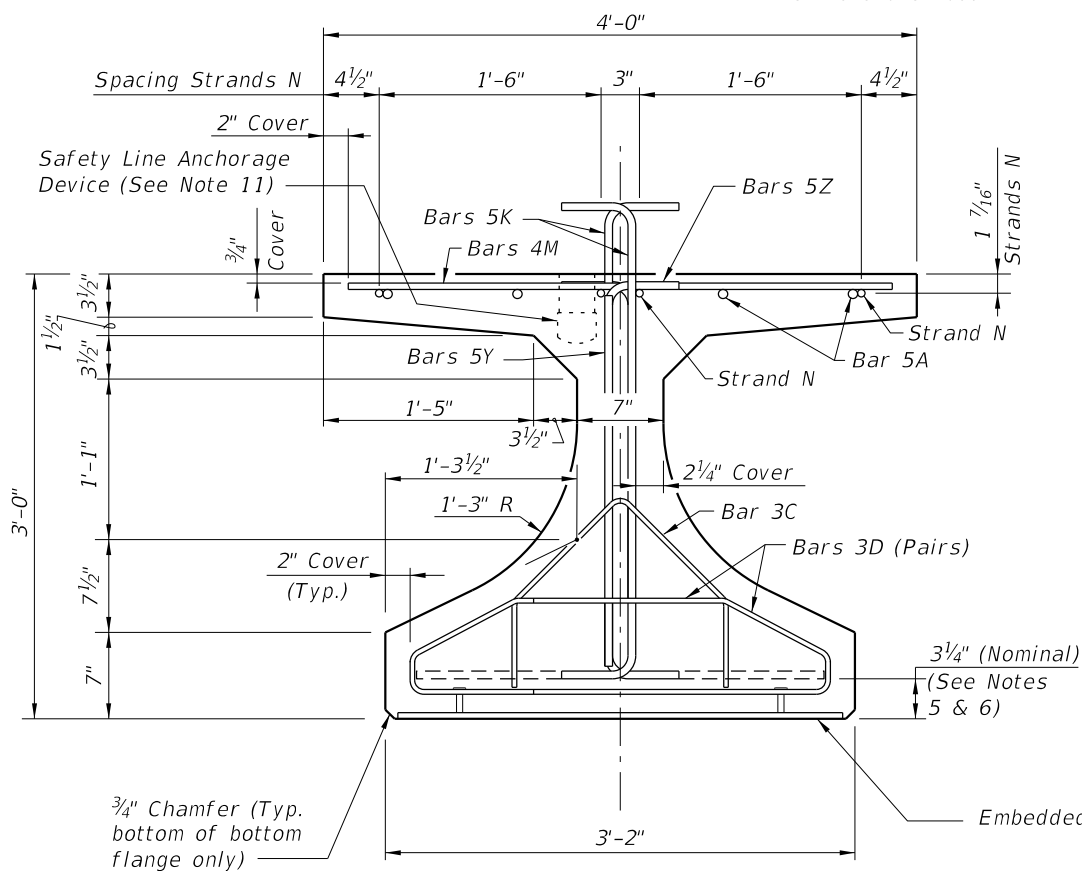

END VIEW

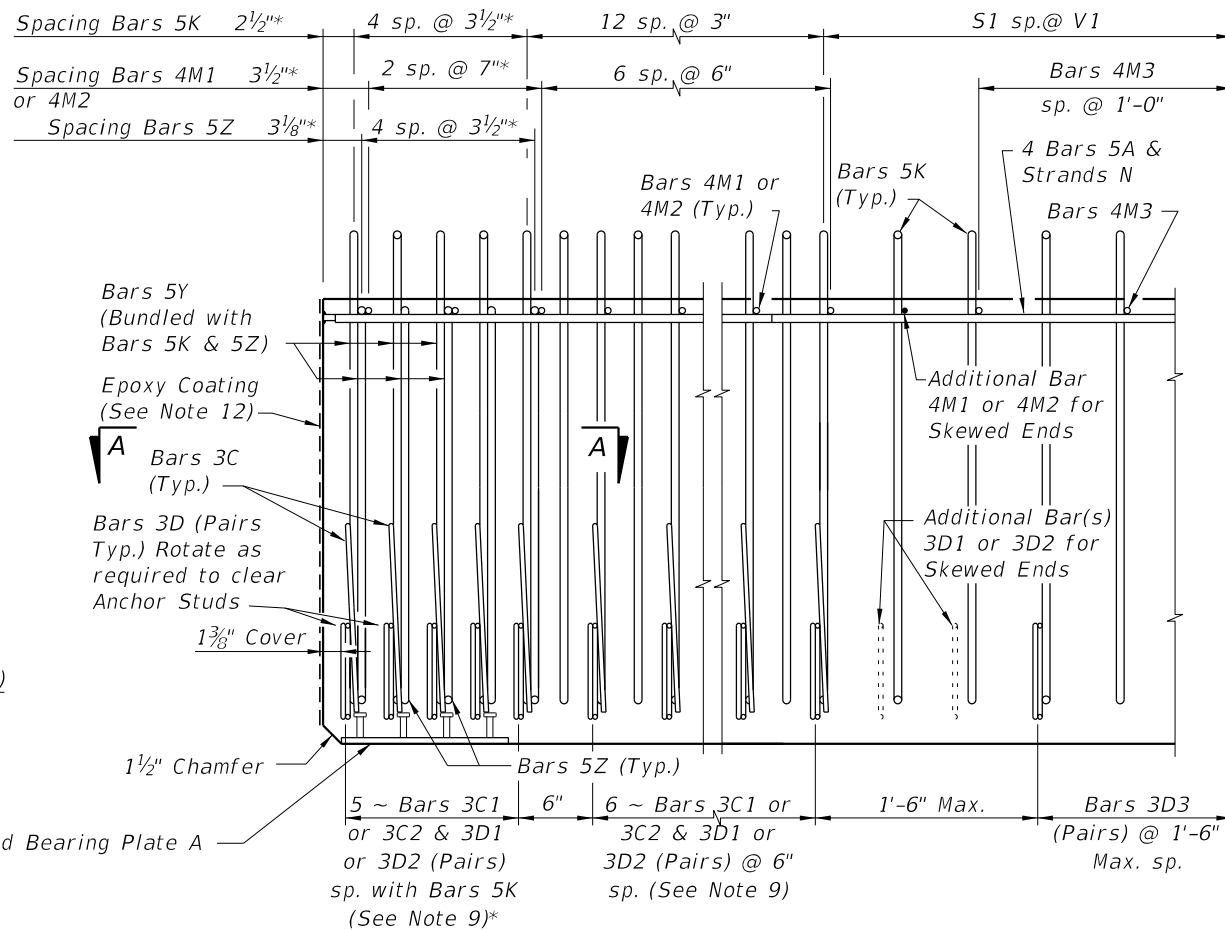

ELEVATION AT END OF BEAM
(Flanges Not Shown For Clarity)
(End 1 Shown, End 2 Similar)

CONVENTIONAL REINFORCING
BAR BENDING DETAILS

BILL OF REINFORCING STEEL

MARK	NOTE NUMBERS	SIZE	NUMBER REQUIRED	LENGTH (NOTE 2)
A	—	5	8	16'-0"
C1	7, 8 & 9	3	11 (End 1)	Varies
C2	7, 8 & 9	3	11 (End 2)	Varies
D1	7, 8, 9 & 10	3	22 (End 1)	Varies
D2	7, 8, 9 & 10	3	22 (End 2)	Varies
D3	9 & 10	3	See Table	4'-3"
K	5, 6, 8, 9 & 10	5	See Table	4'-2"
M1	7 & 9	4	9 (End 1)	Varies
M2	7 & 9	4	9 (End 2)	Varies
M3	9	4	See Table	3'-8"
N	4 & 12	3/8" Ø Strand	4	Dim. L
Y	8 & 9	5	12	2'-6"
Z	5, 6, 8, 9 & 10	5	10	3'-8"

BENDING DIAGRAMS (See Note 2)

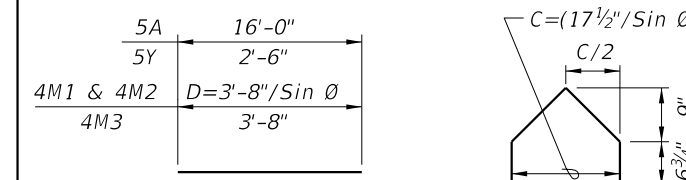

BARS 5A, 4M1, 4M2, BARS 3C1 & 3C2
4M3 & 5Y

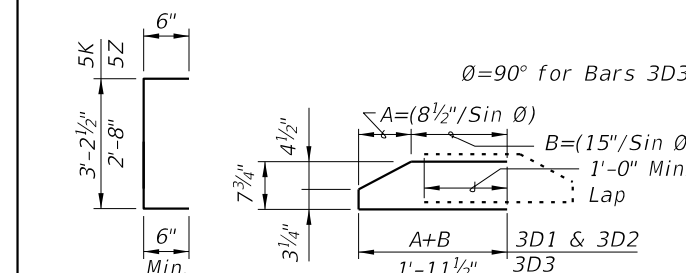

BARS 5K & 5Z BARS 3D1, 3D2 & 3D3

- NOTES:
- A. Work this Index with Index 450-010 - Typical Florida-I Beam Details and Notes and the Florida-I Beam - Table of Beam Variables in Structures Plans.
 - B. For referenced notes, see Index 450-010.
 - C. For Dimensions A, B, C, D, L, R & V1 and number of spaces S1 thru S4, see Florida-I Beam - Table of Beam Variables in Structures Plans.

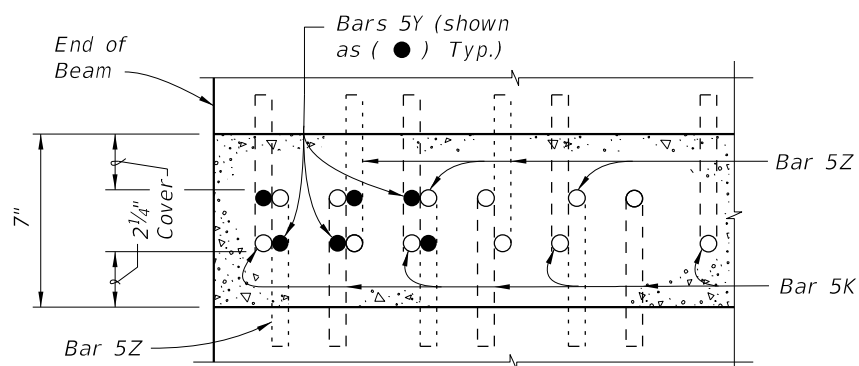

SECTION A-A FOR CONVENTIONAL REINFORCING
(Showing Bars 5K, 5Y & 5Z Only)

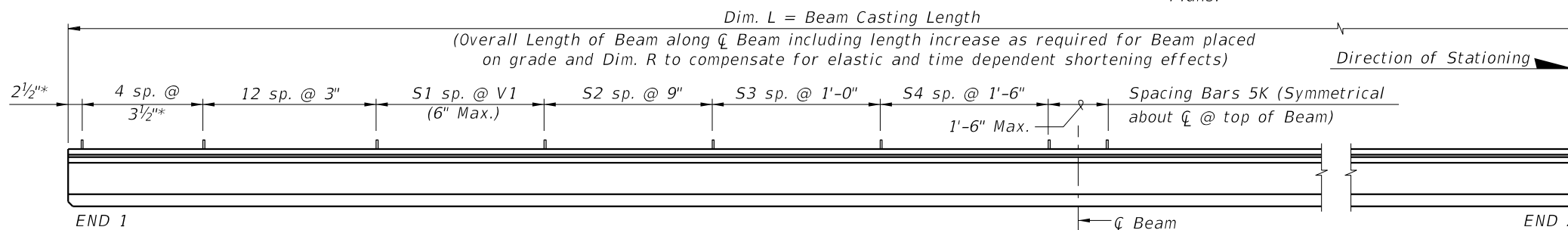

ELEVATION

10/16/2025 8:39:11 AM

LAST REVISION 11/01/19

DESCRIPTION:



FY 2026-27
STANDARD PLANS

FLORIDA-I 36 BEAM - STANDARD DETAILS

INDEX
450-036

SHEET
1 of 2

ALTERNATE REINFORCING STEEL (WWR) DETAILS

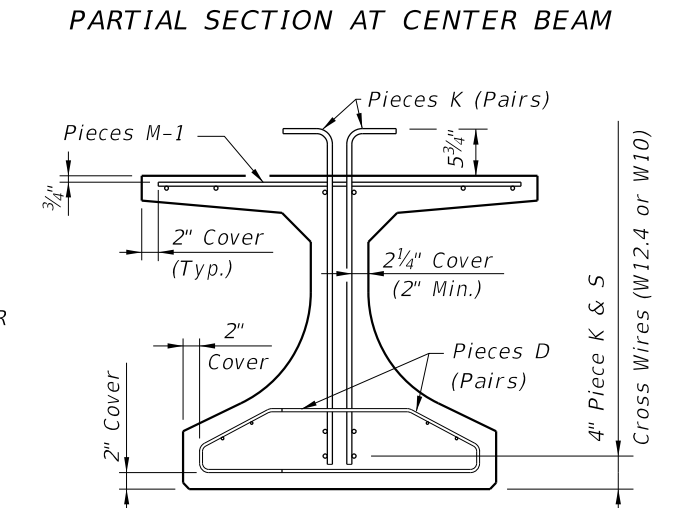
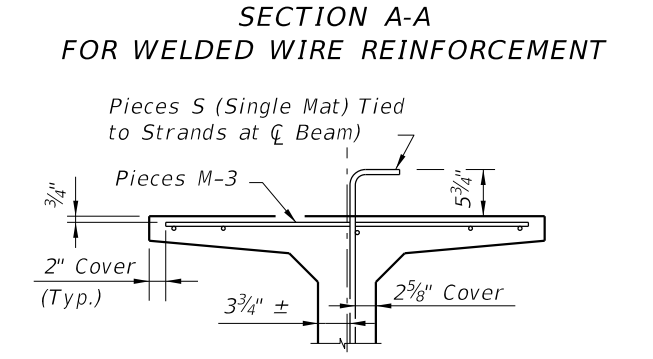
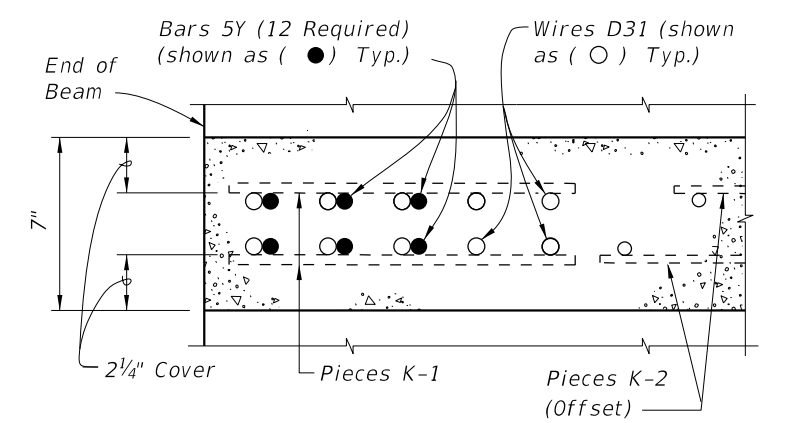
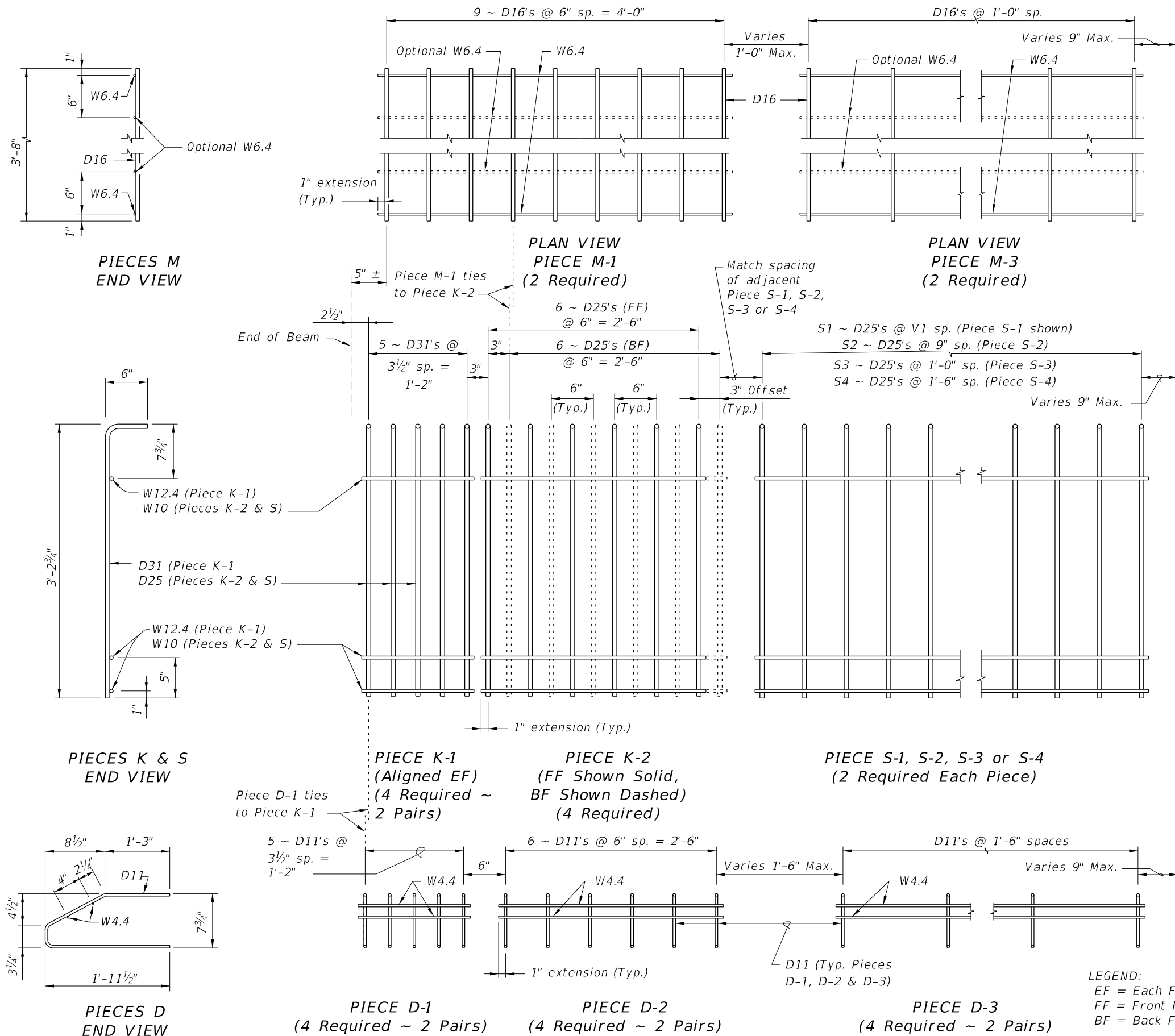

- NOTES:**
- See Sheet 1 for placement details & Table of Beam Variables in Structures Plans for variables S1, S2, S3, S4 & V1.
 - Place Conventional Reinforcement Bars 5A & 3C as shown on Sheet 1. Place additional Bars 5Y as shown in Section A-A for WWR. Bars 5Z will not be used with the WWR Option.
 - Pieces may be fabricated in multiple length sections.
 - For beams with skewed end conditions, Pieces D-1, D-2 & M-1 shall not be used; Conventional Reinforcement Bars D1, D2, C1, C2, M1 & M2 shall be used. See Index 450-010 Skewed Beam End Details and Note 9 for placement details. Shift Pieces K & Bars 5Y to accommodate skewed end conditions and align with Bars C and D.

10/6/2025 2:31:34 PM