

**GENERAL NOTES:**

1. Place concrete pipe with the slots positioned on sides.
2. Alignment joints are standard (gaskets not required). Recorrugation of metal pipe ends not required.
3. Install Type D-3 geotextile in accordance with Specification 514. Lap all geotextile joints a minimum of one (1) foot.
4. Construct the standard cross section unless other section(s) described or detailed in the plans.
5. See Index 430-001 for supplemental details.
6. Take the necessary precautions to prevent contamination of the trench with sand, silt and foreign materials.

TABLE OF CONTENTS:	
Sheet	Description
1	General Notes and Contents
2	French Drain System
3	Concrete Slotted Pipe Options

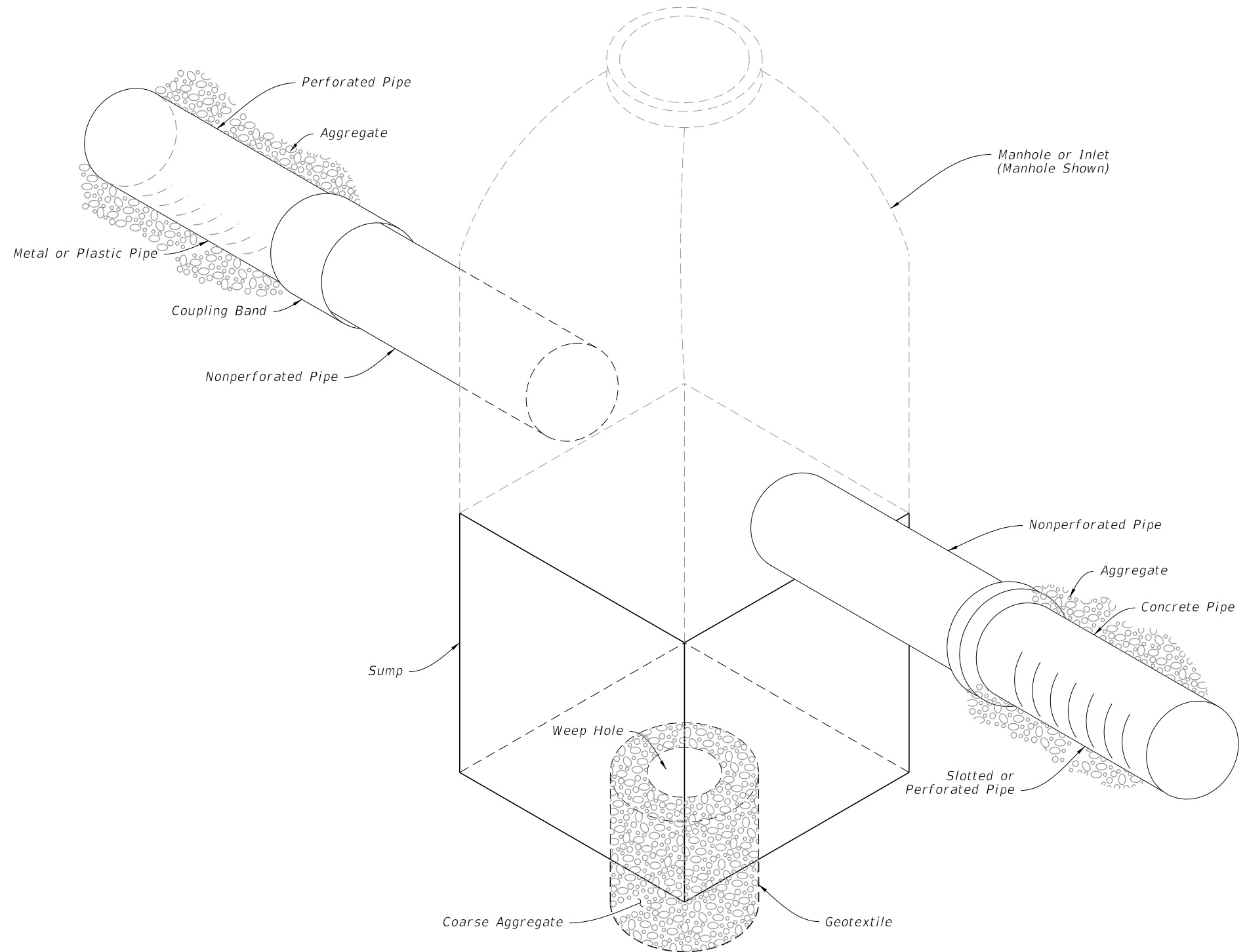

**FRENCH DRAIN ASSEMBLY**

9/26/2025 1:11:57 PM

**NOTES:**

1. Construct sumps unless excluded in the Plans.
2. For additional sump bottom information see Index 425-001.
3. Construct weep holes only where called for in the Plans.
4. Only cast and ductile iron sanitary sewer, or cast iron, ductile and steel water mains will be allowed to pass directly through french drain (without sleeve).
5. Use only steel, cast or ductile iron sleeves.
6. No slots or perforations.

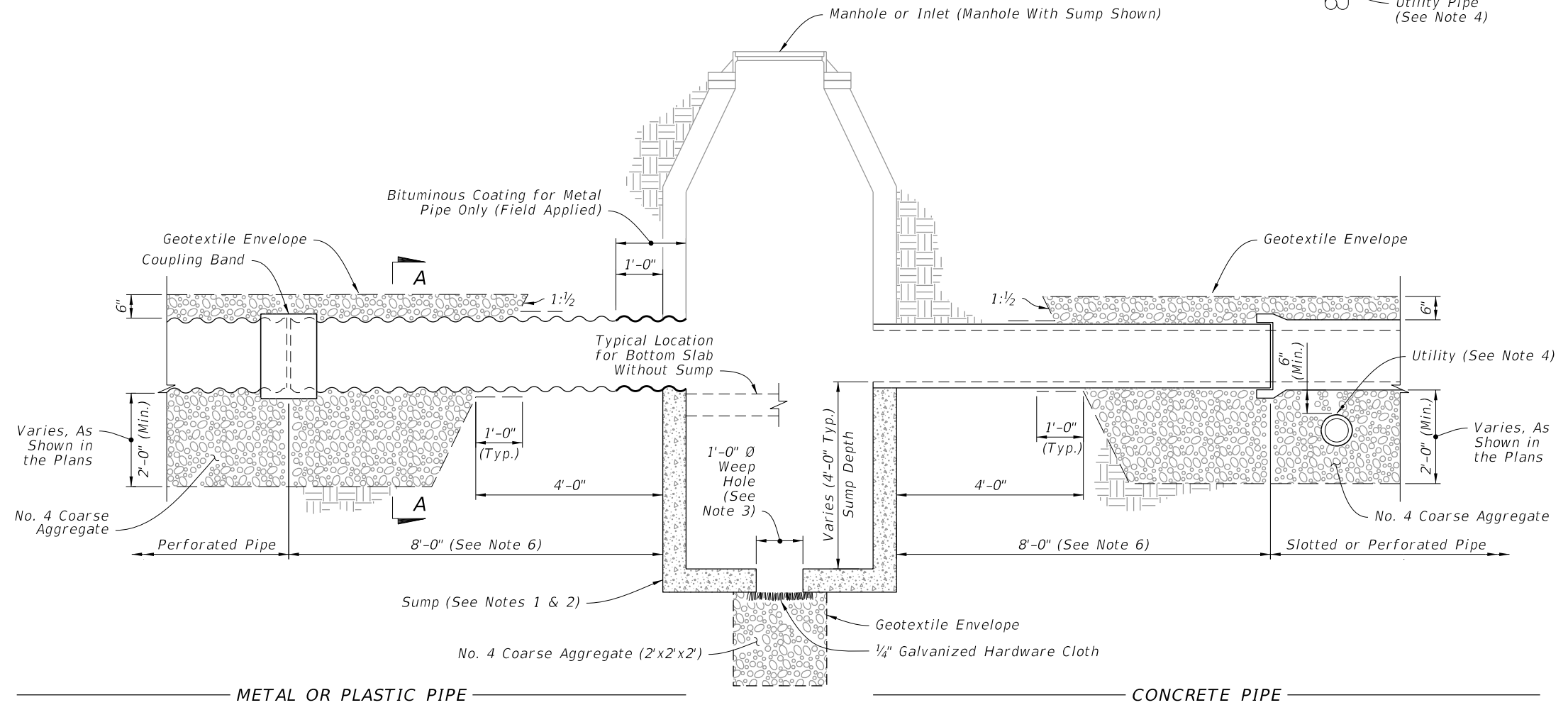
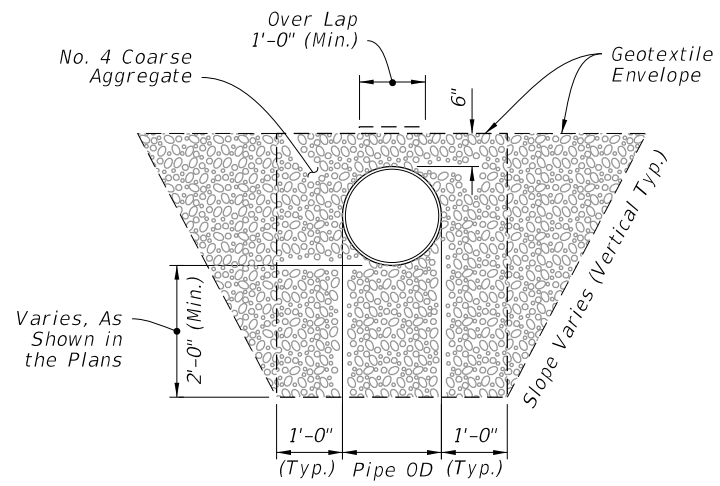
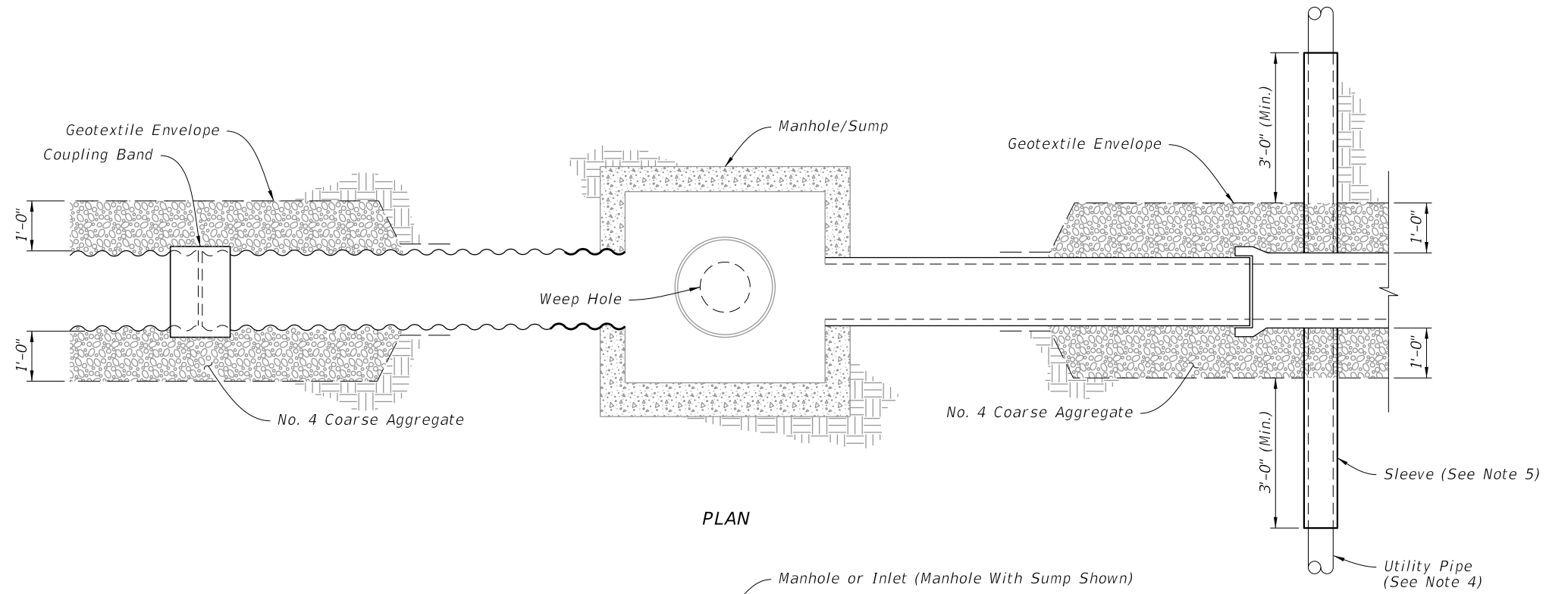

**FRENCH DRAIN (Round Pipe Shown)**

9/26/2025 1:12:03 PM

LAST REVISION 11/01/23	REVISION	DESCRIPTION:	 <b>FY 2026-27 STANDARD PLANS</b>	<b>FRENCH DRAIN</b>	INDEX <b>443-001</b>	SHEET <b>2 of 3</b>
---------------------------	----------	--------------	--	---------------------	-------------------------	------------------------

**FRENCH DRAIN SYSTEM**

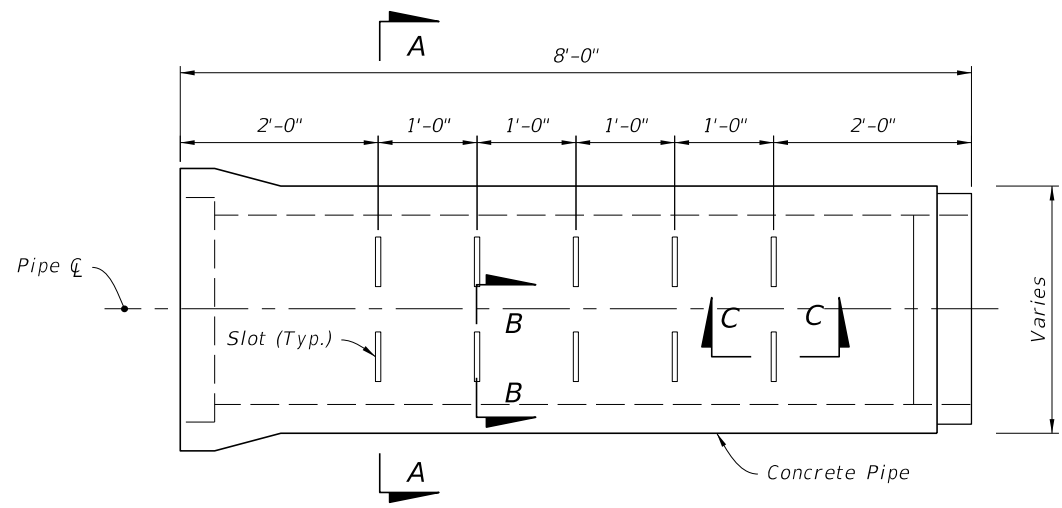

SIDE VIEW

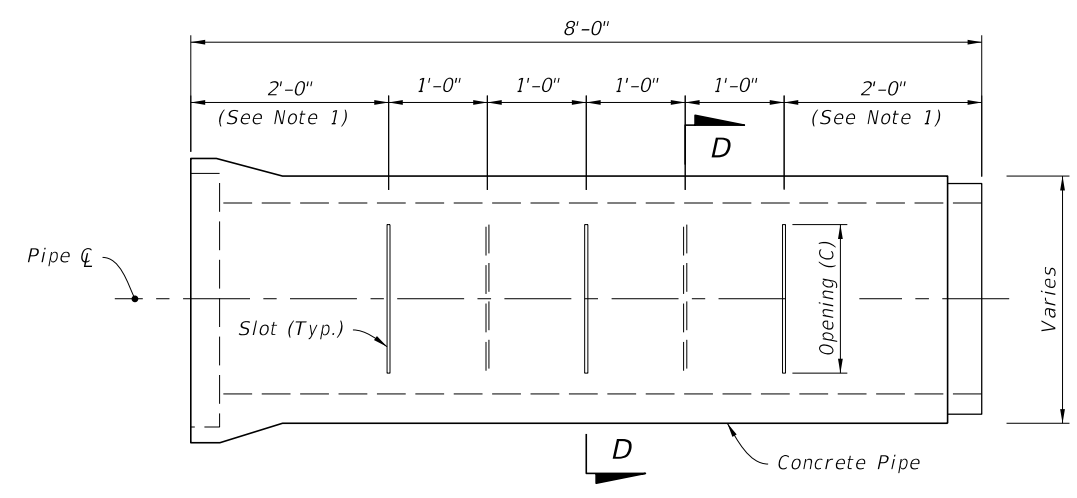

SIDE VIEW

- NOTES:**
- 2'-0" for 8'-0" joints of pipe;  
2'-6" for 12'-0" joints of pipe
  - A curved cut is acceptable provided the control dimension is maintained.

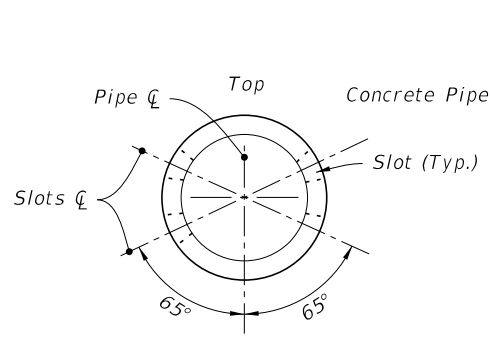

15" to 30"

SECTION A-A

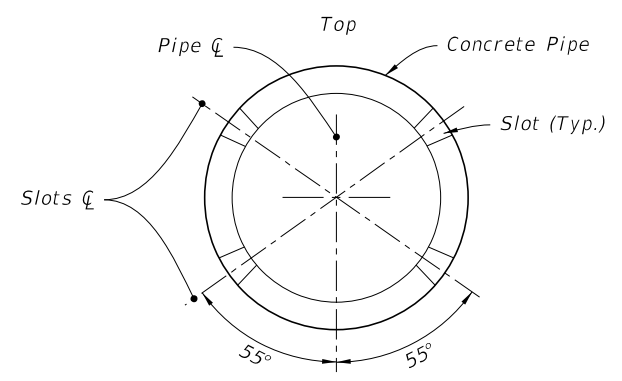

36" to 72"

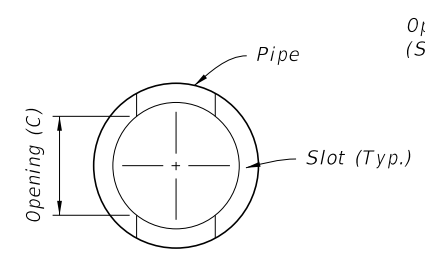

ROUND PIPE

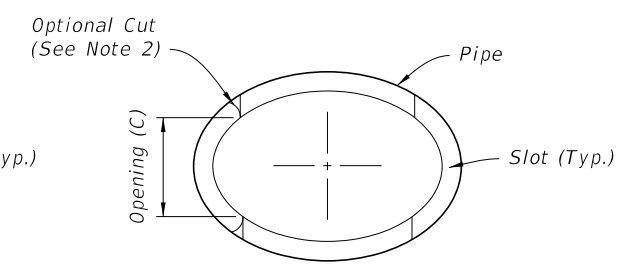

ELLIPTICAL PIPE

ROUND PIPE		
Pipe Size	Slot Cut	
	Opening (C)	
	Min.	Max.
15"	12"	14"
18"	12"	14"
24"	16"	18"
30"	16"	18"
36"	22"	24"
42"	22"	24"
48"	22"	24"
54"	24"	26"
60"	24"	26"
66"	24"	26"
72"	24"	26"

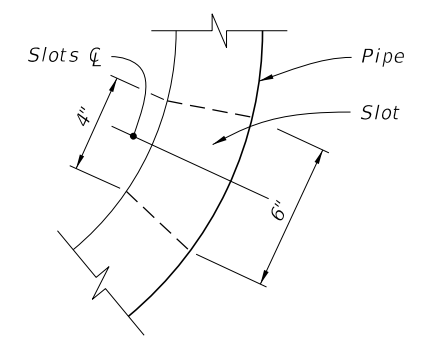

SECTION B-B

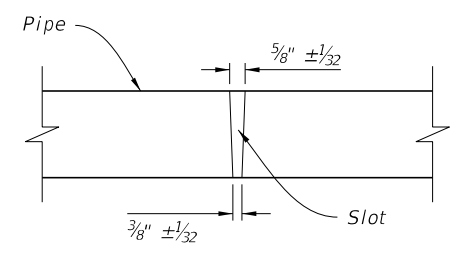

SECTION C-C

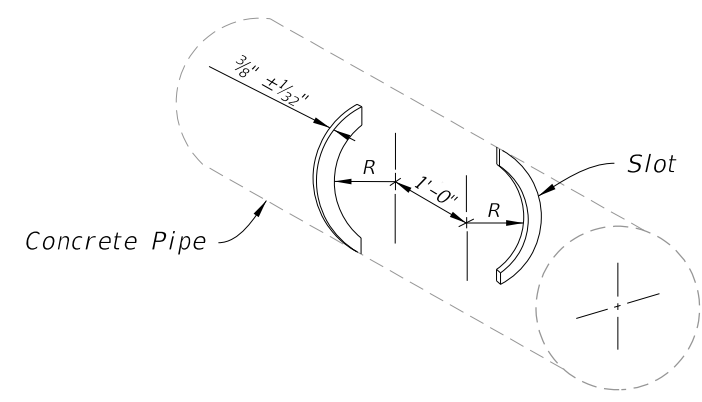

ISOMETRIC VIEW  
(Round Pipe Shown)

ELLIPTICAL PIPE		
Pipe Size	Slot Cut	
	Opening (C)	
	Min.	Max.
14"x23"	10"	12"
19"x30"	14"	16"
24"x38"	14"	16"
29"x45"	20"	22"
34"x53"	20"	22"
38"x60"	20"	22"

OPTION A - ROUND PIPE

OPTION B - ROUND OR ELLIPTICAL PIPE

CONCRETE SLOTTED PIPE OPTIONS

9/26/2025 1:12:09 PM