

GENERAL NOTES:

1. Use Class II concrete.
2. Chamfer all exposed edges $\frac{3}{4}$ ".
3. See Index 550-002 for details of Type B fencing.
4. Quantities shown are for estimating purposes only.
5. Install Type D-2 geotextile in accordance with Specification 514.

TABLE OF CONTENTS:

Sheet	Description
1	General Notes and Contents
2	Dimensional Details
3	Reinforcing Details and Bending Diagram

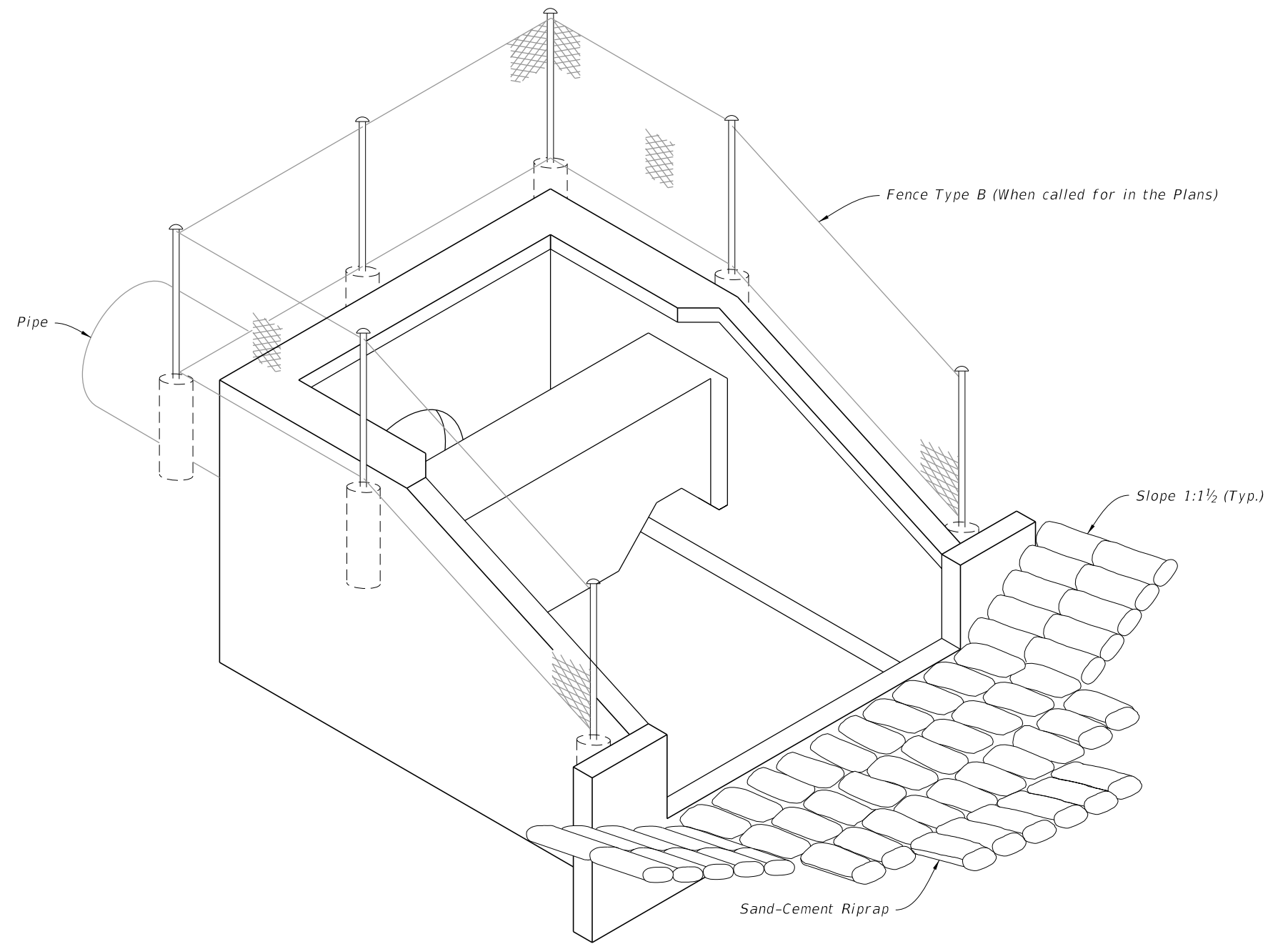

U-TYPE CONCRETE ENDWALLS

9/26/2025 12:58:44 PM

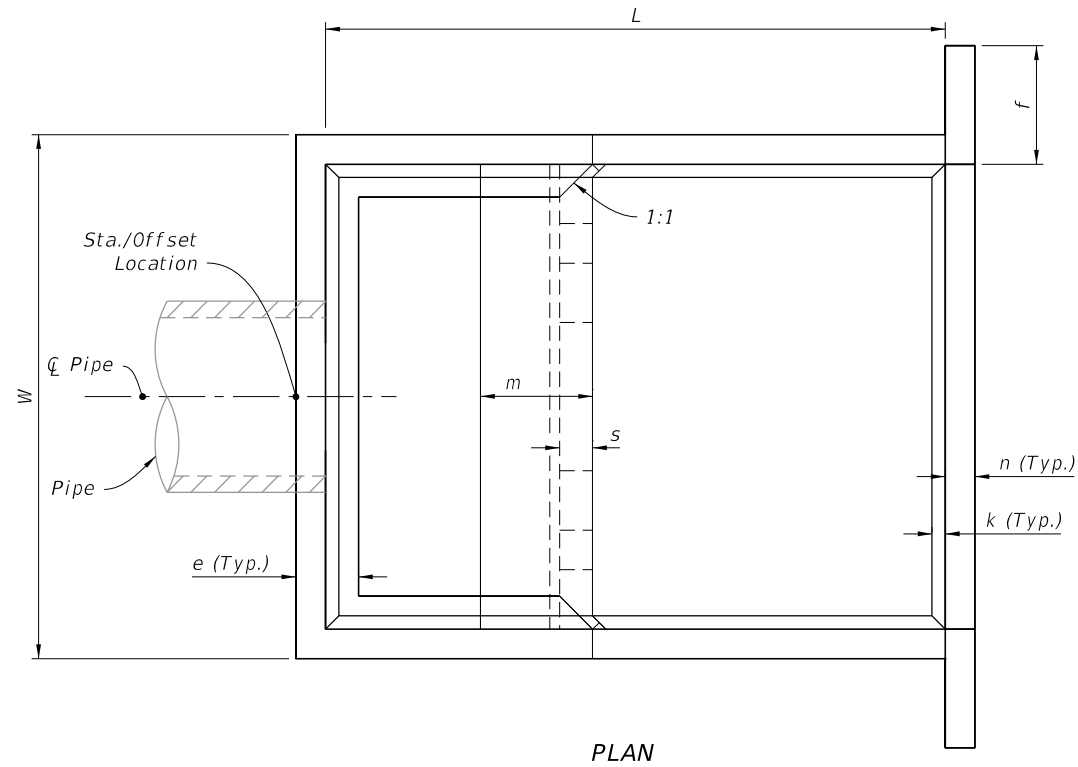

Pipe		DIMENSION TABLE																Concrete (CY)	Reinf. Steel (lb)	Sand-Cement Riprap (Nom.) (CY)
Dia.	Area (SF)	Feet - Inches										Inches								
		W	Ht	L	a	b	c	d	e	f	g	m	n	p	s	t	k			
30"	4.91	9-0	6-3	10-8	4-7	6-1	3-4	1-4	1-2	2-6	3-0	1-11	6	6½	7	7	3	6.72	736	10.6
36"	7.07	10-5	7-3	12-4	5-3	7-1	3-10	1-7	1-3	3-0	3-6	2-3	7	7½	8	8	3	10.34	1,072	13.6
42"	9.62	11-10	8-0	14-0	6-0	8-0	4-5	1-9	1-6	3-0	3-11	2-6	8	8½	9	8	4	14.82	1,429	17.5
48"	12.57	13-3	9-0	15-8	6-9	8-11	4-11	2-0	1-7	3-0	4-5	2-10	9	9½	10	8	4	20.36	2,000	22.1
54"	15.90	14-8	9-9	17-4	7-4	10-0	5-5	2-2	1-10	3-0	4-11	3-0	10	10½	10	8	4	27.19	2,659	27.2
60"	13.63	16-1	10-9	19-0	8-0	11-0	5-11	2-5	1-11	3-0	5-4	3-4	11	11½	11	8	6	34.49	3,552	32.5
66"	23.76	17-3	11-6	20-6	8-8	11-10	6-5	2-7	2-1	3-0	5-9	3-7	12	12½	12	8	6	42.82	4,472	38.3
72"	28.27	18-6	12-3	22-0	9-3	12-9	6-11	2-9	2-3	3-0	6-2	3-9	12	12½	12	8	6	50.68	5,426	44.5

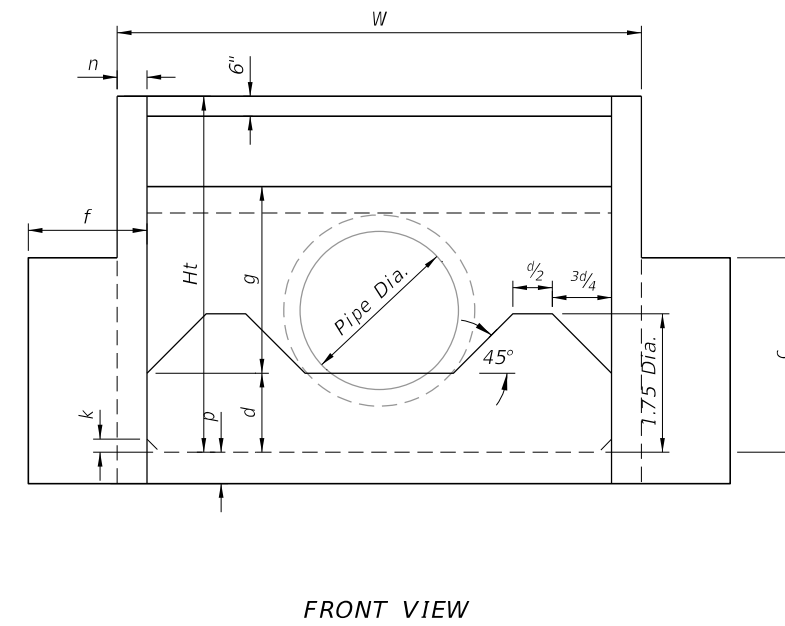
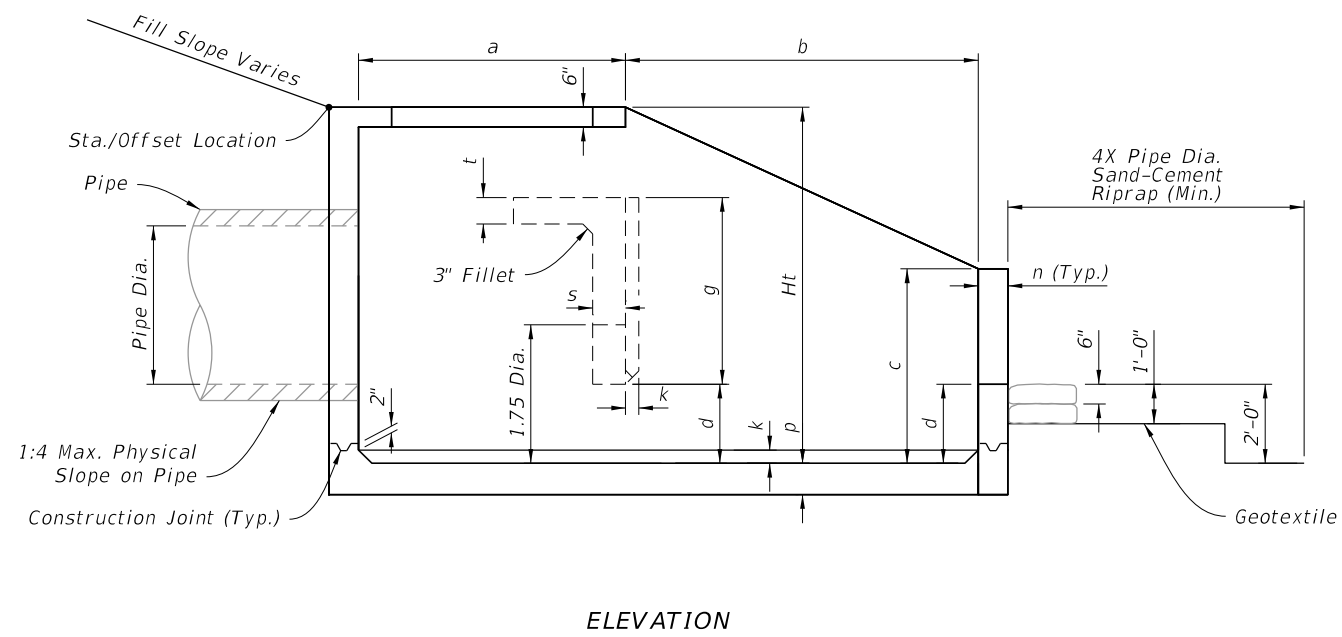

DIMENSIONAL DETAILS

DIMENSIONAL DETAILS

10/14/2025 10:44:10 AM

LAST REVISION 11/01/23	DESCRIPTION:
---------------------------	--------------



FY 2026-27
STANDARD PLANS

U-TYPE CONCRETE ENDWALLS
ENERGY DISSIPATOR 30" TO 72" PIPE

INDEX
430-012

SHEET
2 of 3

NOTES:

1. All bar dimensions are measured out to out.
2. All Bars are size #4 unless otherwise noted.
3. Install reinforcing steel with a minimum of 2" cover.
4. Bars B_6 and B_7 (N.S. and F.S.) equivalent in size to B_5 (cut and bend as required)
5. Bars $V_1, V_2, V_3, V_4, V_5, H_1, H_2, H_3, H_4,$ and H_5 are straight bars.

LEGEND:

- H = Horizontal Bars
- V = Vertical Bars
- B = Bent Bars
- D = Dowels or Diagonal Bars

BENT BARS TABLE												
Pipe	B_1		B_2		B_3		B_4		B_5		B_{10}	
	Size (No.)	Spacing (Ft.-In.)	Size (No.)	Spacing (Ft.-In.)	Size (No.)	Spacing (Ft.-In.)	Size (No.)	Spacing (Ft.-In.)	Size (No.)	Spacing (Ft.-In.)	Size (No.)	Spacing (Ft.-In.)
30"	4	0-9½	4	1-6	5	0-11	4	0-9½	5	0-5½	4	0-9½
36"	5	1-0	4	1-6	5	0-10	5	1-0	5	0-5	5	1-0
42"	5	0-11	4	1-6	6	1-1	5	0-11	6	0-6½	5	0-11
48"	5	0-9½	4	1-0	6	1-0	5	0-9½	6	0-6	5	0-9½
54"	5	0-8½	4	0-10	7	1-1	5	0-8½	7	0-6½	5	0-8½
60"	6	0-10	5	1-1	7	1-0	6	0-10	7	0-6	6	0-10
66"	6	0-8½	5	0-11½	7	0-11	6	0-8½	7	0-5½	6	0-8½
72"	6	0-7½	5	0-10	7	0-10	6	0-7½	7	0-5	6	0-7½

BARS $B_5, B_8, B_{10}, B_{11}, B_{12}$

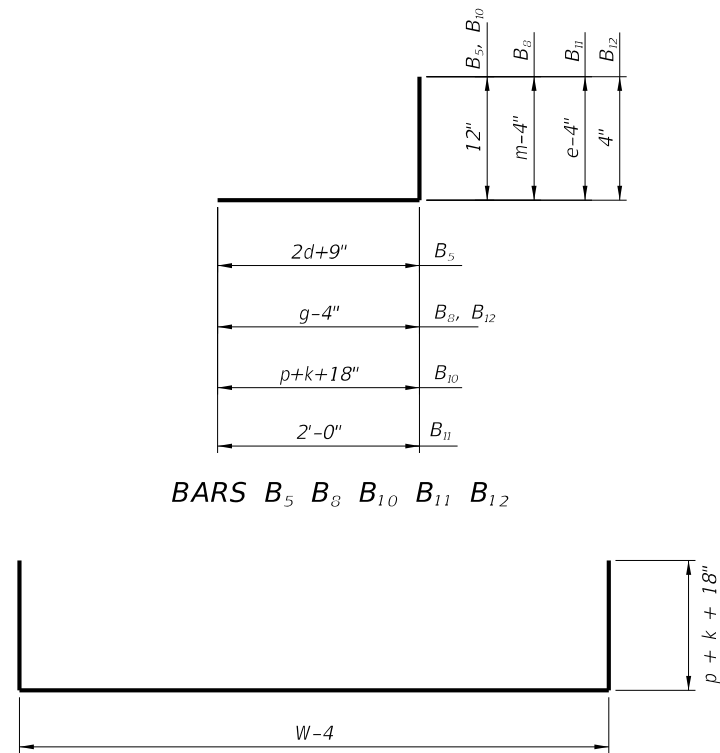

BENDING DIAGRAM

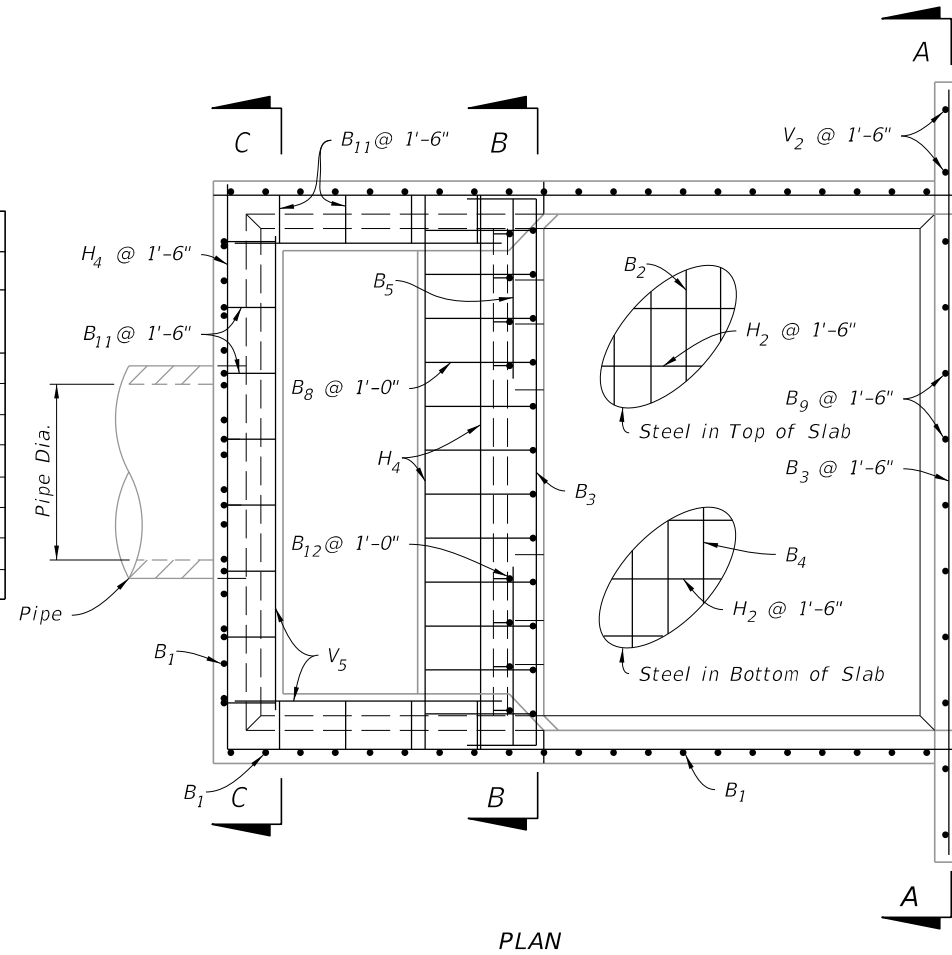

PLAN

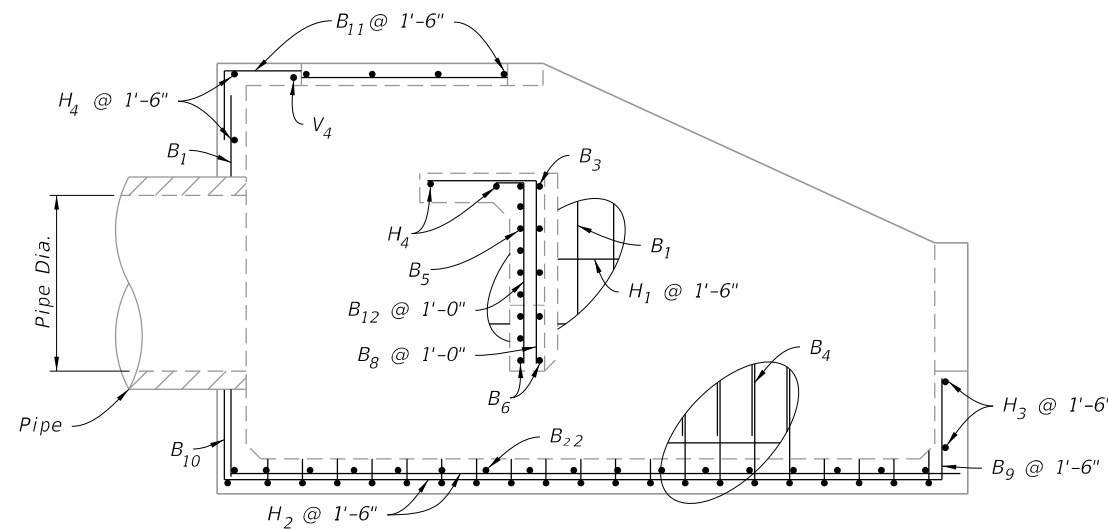

ELEVATION

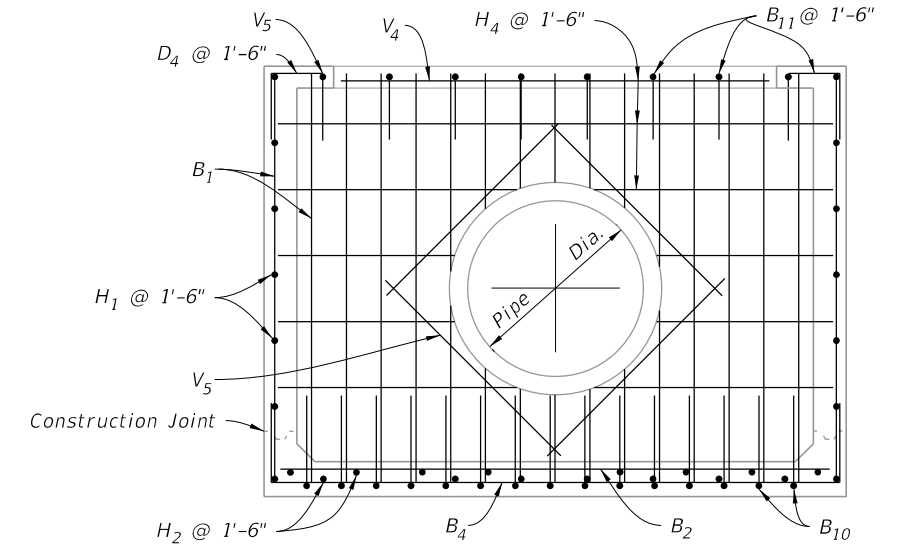

SECTION C-C

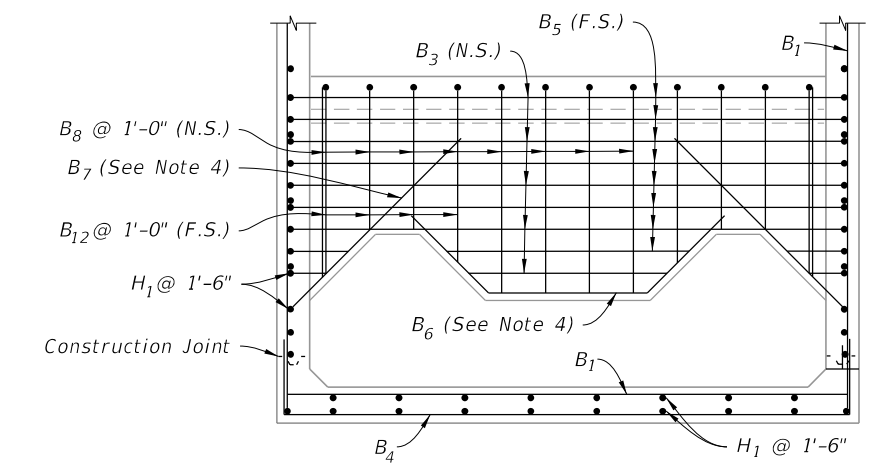

SECTION B-B

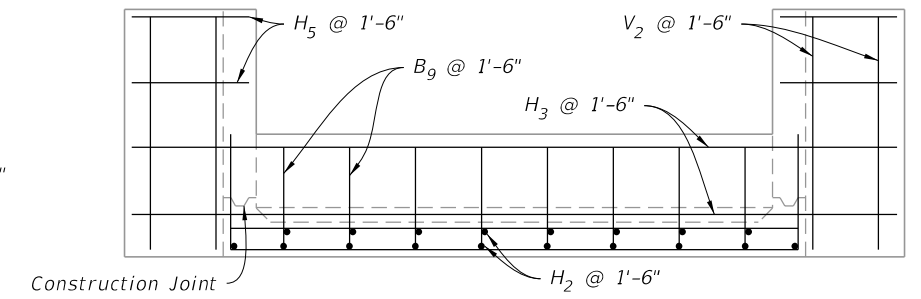

SECTION A-A

REINFORCING DETAILS

REINFORCING DETAILS AND BENDING DIAGRAM

10/14/2025 10:44:42 AM

LAST REVISION 11/01/19	DESCRIPTION:
---------------------------	--------------



FY 2026-27
STANDARD PLANS

U-TYPE CONCRETE ENDWALLS
ENERGY DISSIPATOR 30" TO 72" PIPE

INDEX
430-012

SHEET
3 of 3