

GENERAL NOTES:

1. Work this Index with Index 425-001 and Index 425-010.
2. Use Grade 60 reinforcing bars with 2" minimum cover unless otherwise shown. See Index 425-001 for equivalent area of welded wire fabric. Cut or bend bars out of way of pipe when necessary. Bars to clear pipe by 1½".
3. Recommended maximum pipe sizes are 24" longitudinal and 30" transverse. For larger pipe, inlets with Alt. B bottoms, Index 425-010 is recommended.
4. All dimensions are for both precast and cast-in-place inlets unless otherwise shown.

TABLE OF CONTENTS:	
Sheet	Description
1	General Notes and Contents
2	Dimensional and Reinforcing Details

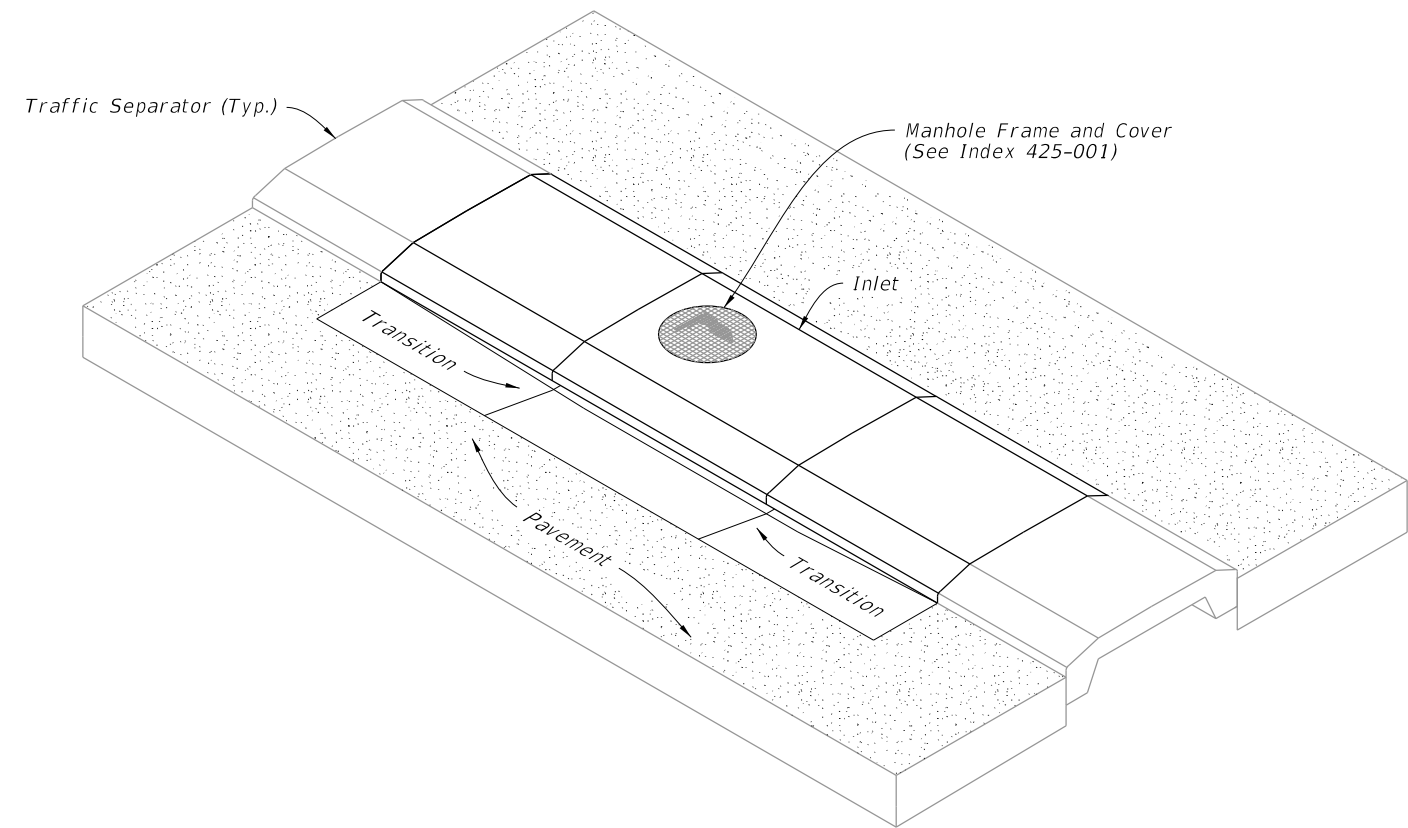

CURB INLET TYPE 7
(Bottom Not Shown)

9/26/2025 11:49:23 AM

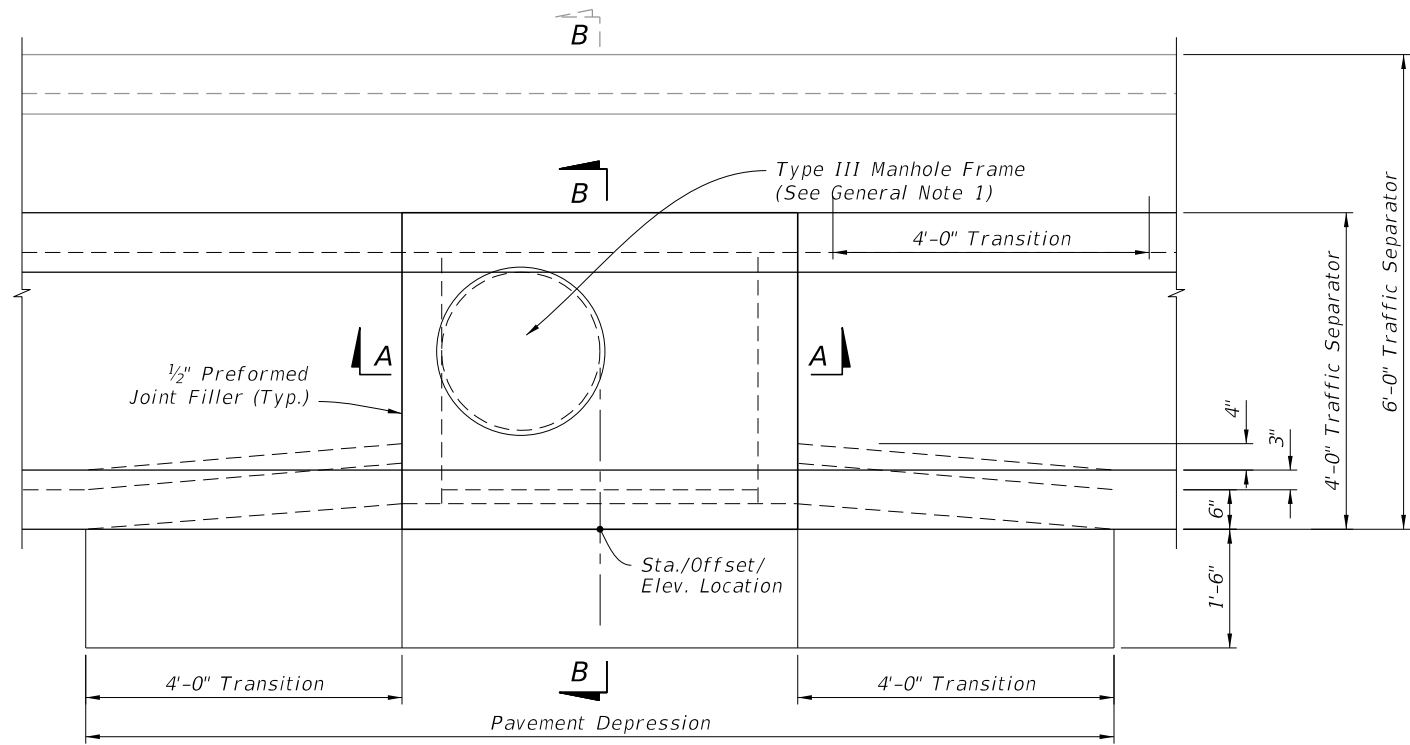

PLAN

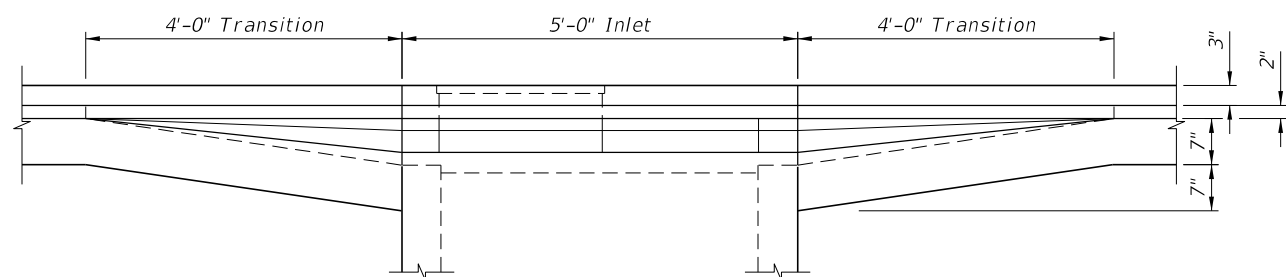

FRONT ELEVATION

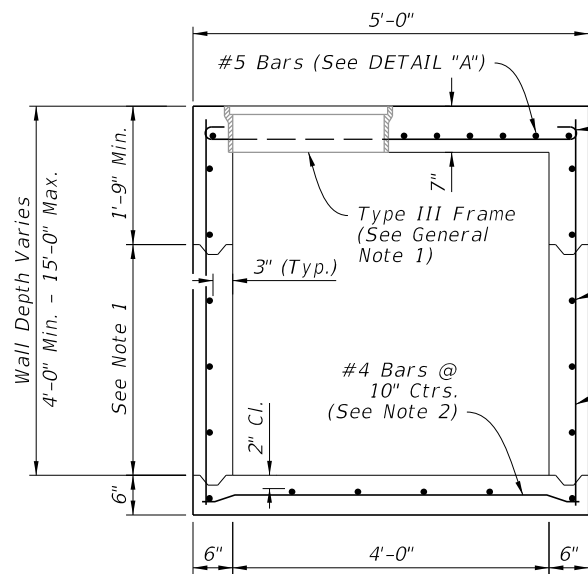

SECTION A-A

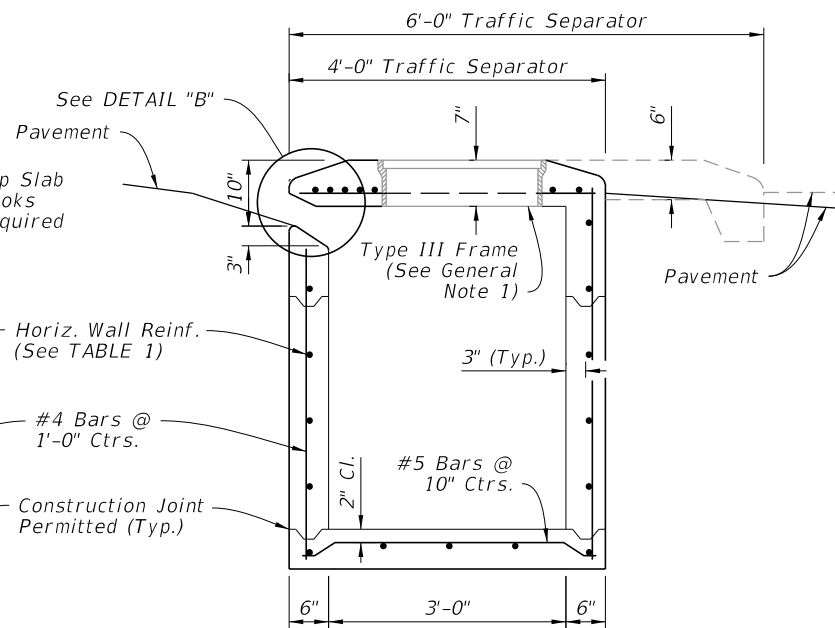

SECTION B-B

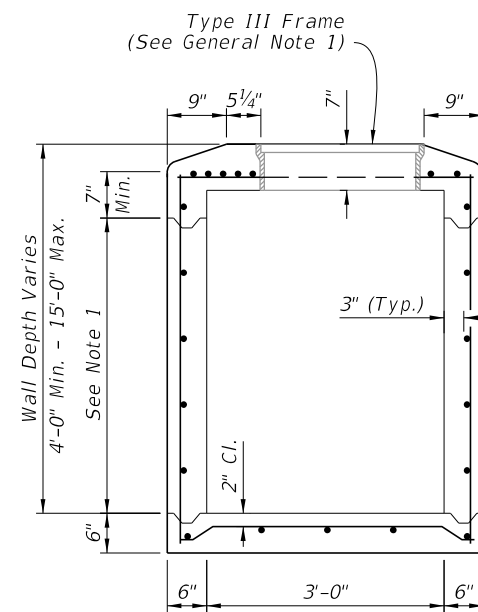

MANHOLE MODIFICATION

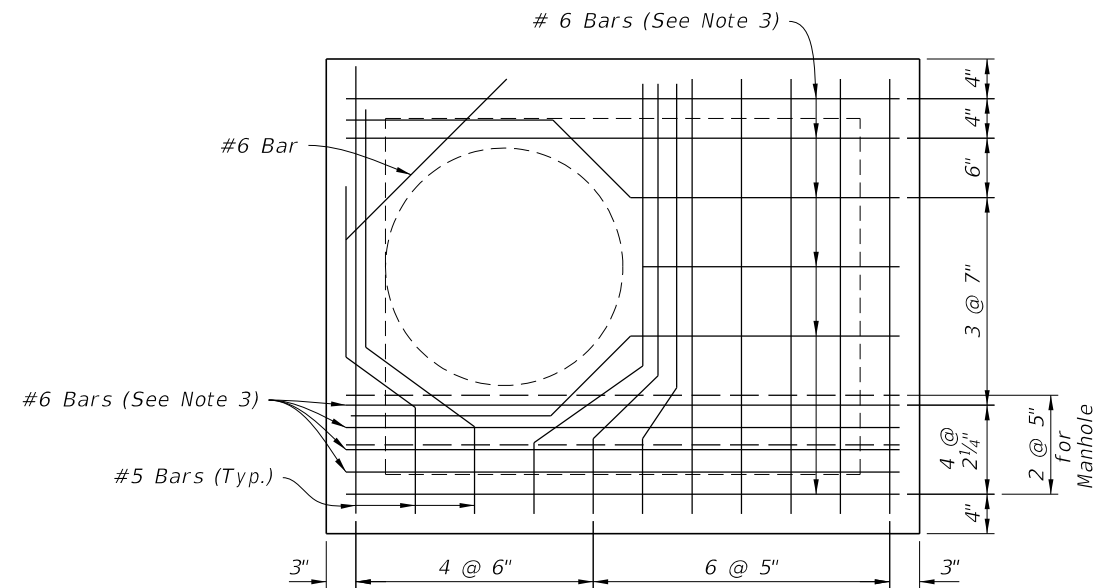

DETAIL "A"

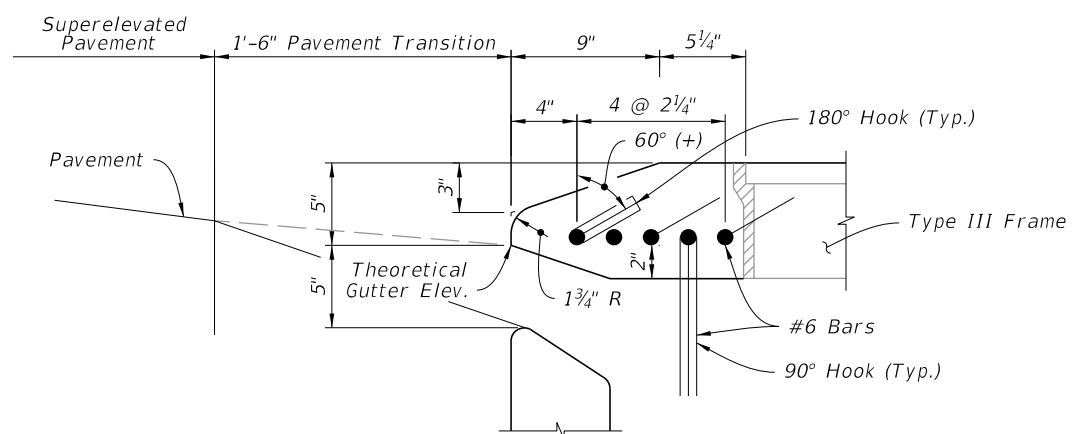

DETAIL "B"

NOTES:

- Construction joints permitted between these limits. See Index 425-001 for minimum dimensions.
- For bottom slab rebar embedment options, see optional construction joints, Index 425-001.
- ACI standard hooks required each end of straight bars and right end of bent bars: 180° hooks, canted 60°(+), on odd bars; 90° hooks, down, on even bars numbered from throat side.

TABLE 1 - HORIZONTAL WALL REINFORCING SCHEDULE

WALL DEPTH	SCHEDULE	AREA (in. ² /ft.)	MAX. SPACING	
			BARS	WWR
0' - 6'	A12	0.20	12"	8"
6' - 10'	A6	0.20	6"	5"
10' - 13'	A4	0.20	4"	3"
10' - 15'	B5.5	0.24	5 1/2"	5"

DIMENSIONAL AND REINFORCING DETAILS

10/14/2025 9:56:41 AM

LAST REVISION 11/01/20	DESCRIPTION:
---------------------------	--------------



FY 2026-27
STANDARD PLANS

CURB INLET TYPE 7

INDEX
425-022

SHEET
2 of 2