

GENERAL NOTES:

1. Work this Index with Specification 425 and Index 425-001.
2. Type P standard structure bottoms are 4'-0" diameter and smaller (Alt. A) and 3'-6" square (Alt. B). Larger standard structure bottoms are designated Type J. Risers are permitted for all structures.
3. Walls of circular structures (Alt. A) constructed in place may be of brick or reinforced concrete. Construct precast and rectangular structures (Alt. B) with reinforced concrete only.
4. Wall thickness and reinforcement are for either reinforced cast-in-place or precast concrete units except that precast circular units may be furnished with walls in accordance with ASTM C478 (See Table 1).
5. Top and bottom slab thickness and reinforcement are for precast and cast-in-place construction. Use Class II concrete, except when Class IV concrete is shown in the Plans.
6. Alt. A or Alt. B structure bottoms may be used in conjunction with curb inlet tops Types 1, 2, 3, 4, 5, 6, 9, and 10, and any manhole or junction box. Alt. B structure bottoms may be used in conjunction with curb inlet Types 7 & 8, or any ditch bottom inlet.
7. Rectangular structures may be rotated as directed by the Engineer in order to facilitate connections between the structure walls and pipes.
8. Use straight embedment reinforcement in top and bottom slabs, except when ACI hooks are specifically required.
9. Construct corner fillets as shown for rectangular structures used with circular risers and inlet throats, and when used on skew with rectangular risers, inlets, and inlet throats. Construct fillets in the top slab of the Alt. A structure bottoms when used with the Type B risers. Reinforce each fillet with two #5 bars.
10. Units larger than specified standards may be substituted at the contractor's option when these units will not cause or increase the severity of utility conflicts. Furnish such larger units at no additional cost to the Department. Larger Alt. A units cannot replace Alt. B units without approval of the Engineer. This Note applies to this Index only.

REINFORCEMENT NOTES:

1. Locate wall reinforcement in rectangular structures as shown in the WALL REINFORCEMENT SPLICE DETAILS in Index 425-001.
2. Provide a minimum 2" clear cover for all reinforcement unless otherwise noted and except for 3'6" diameter ASTM C478 units.
3. Additional bars used to restrain hole formers for precast structures with grouted pipe connections may be left flush with the hole surface.
4. Cut or bend reinforcement at pipe openings to maintain cover.
5. Remove exposed ends of reinforcing at precast pipe openings and grouted joints to 1" below the concrete surface and seal with a Type F Epoxy meeting the requirements of Specification 926.
6. Equivalent area smooth or deformed welded wire reinforcement may be substituted in accordance with Index 425-001.

TABLE OF CONTENTS:	
Sheet	Description
1	General Notes and Contents
2	Dimensional and Reinforcing Details
3	Tables 1, 2, 3, and 4
4	Tables 5 and 6

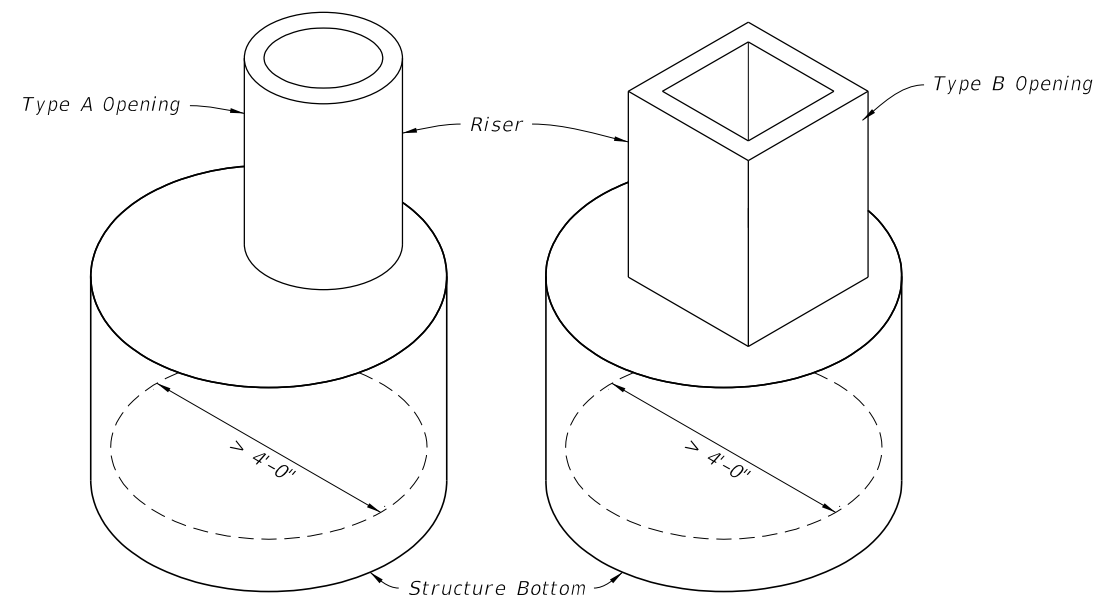

ALTERNATE A

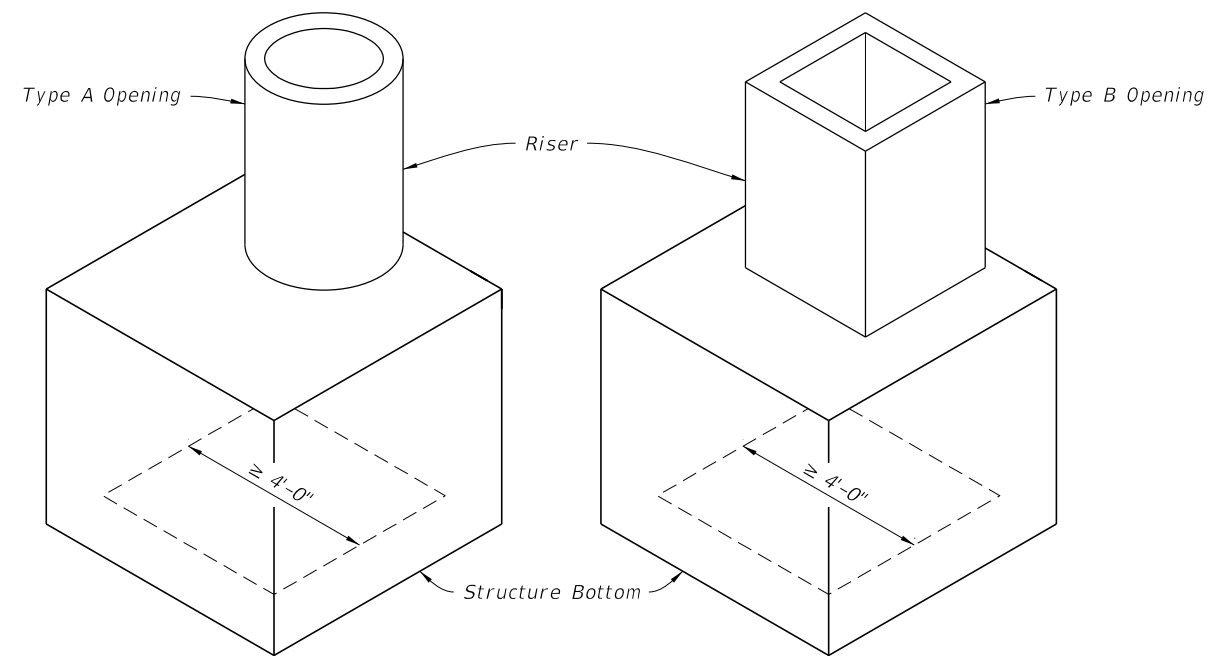

ALTERNATE B

TYPE J

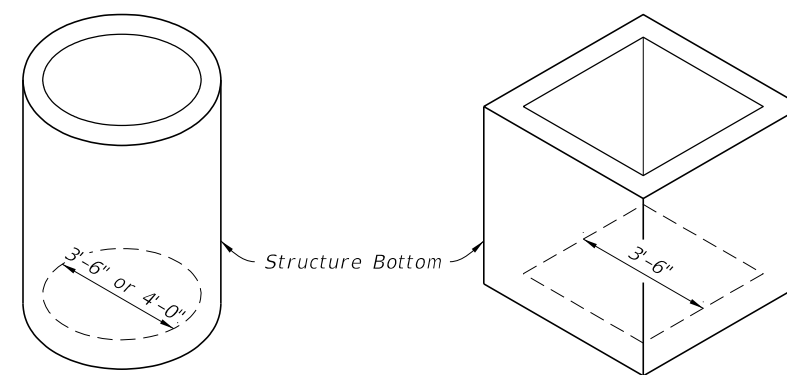

ALTERNATE A

ALTERNATE B

TYPE P

9/26/2025 11:46:55 AM

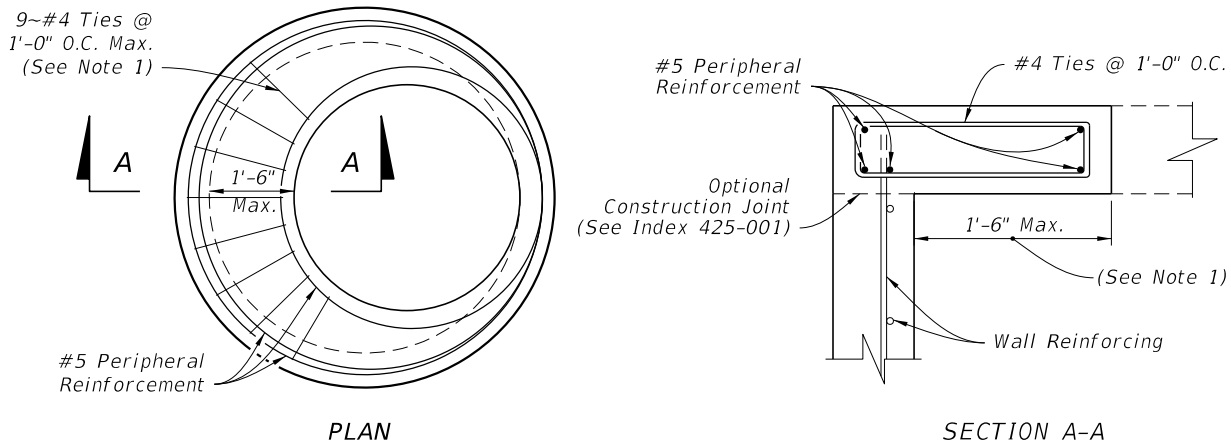

- ALTERNATE A NOTES:**
1. Rotate #4 Bars as required to maintain cover.
 2. Construct the top or riser of the structure according to the top slab to the "Special Top Slab" details, when the inside diameter of a round structure is not more than 1'-6" larger than the opening in the riser or top slab.
 3. Alternate A slab reinforcing not applicable for Type A, B, C, D & E Ditch Bottom Inlets or Type S & V Gutter Inlets. See Indexes 425-040, 425-041, 425-050, 425-051, and 425-052.

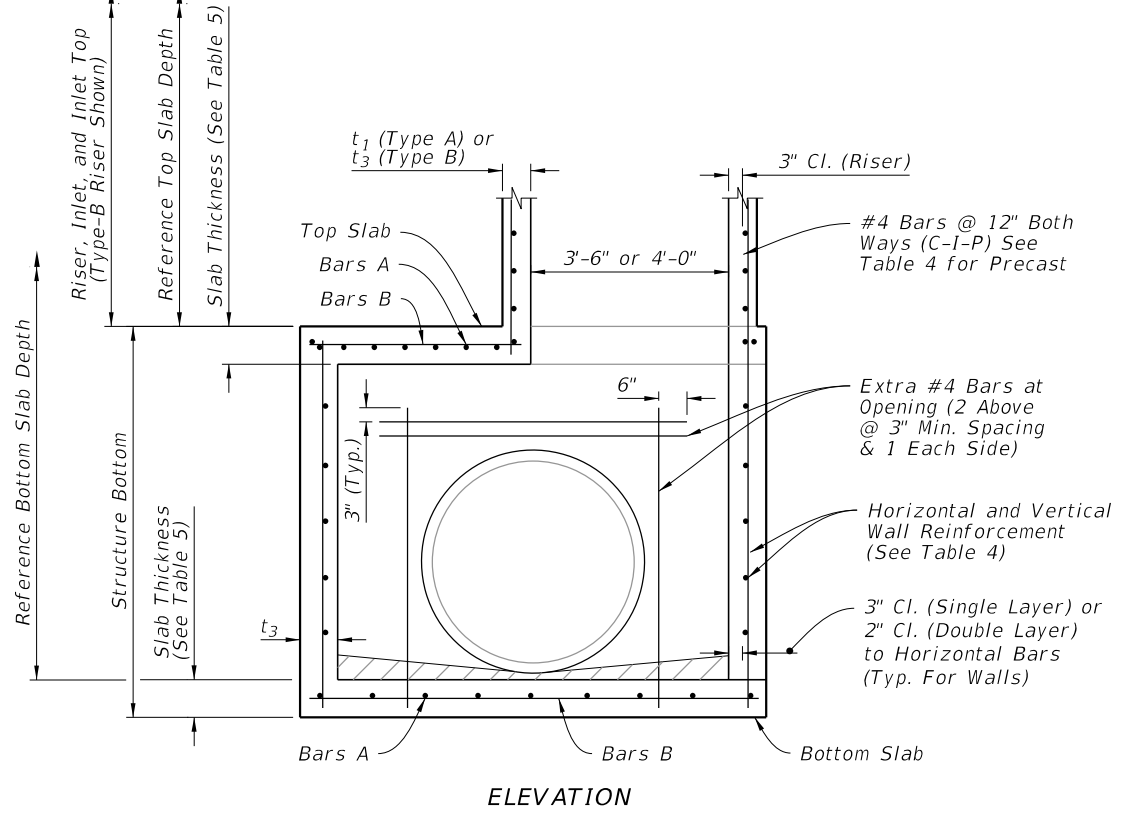
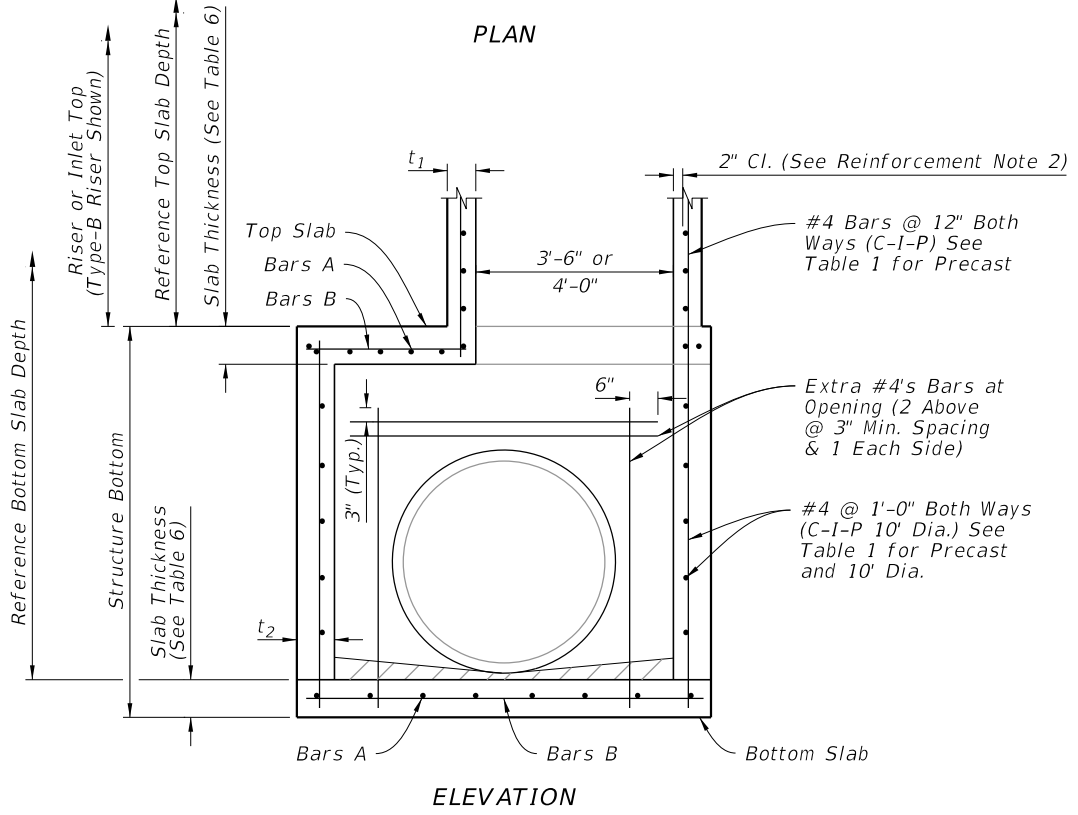
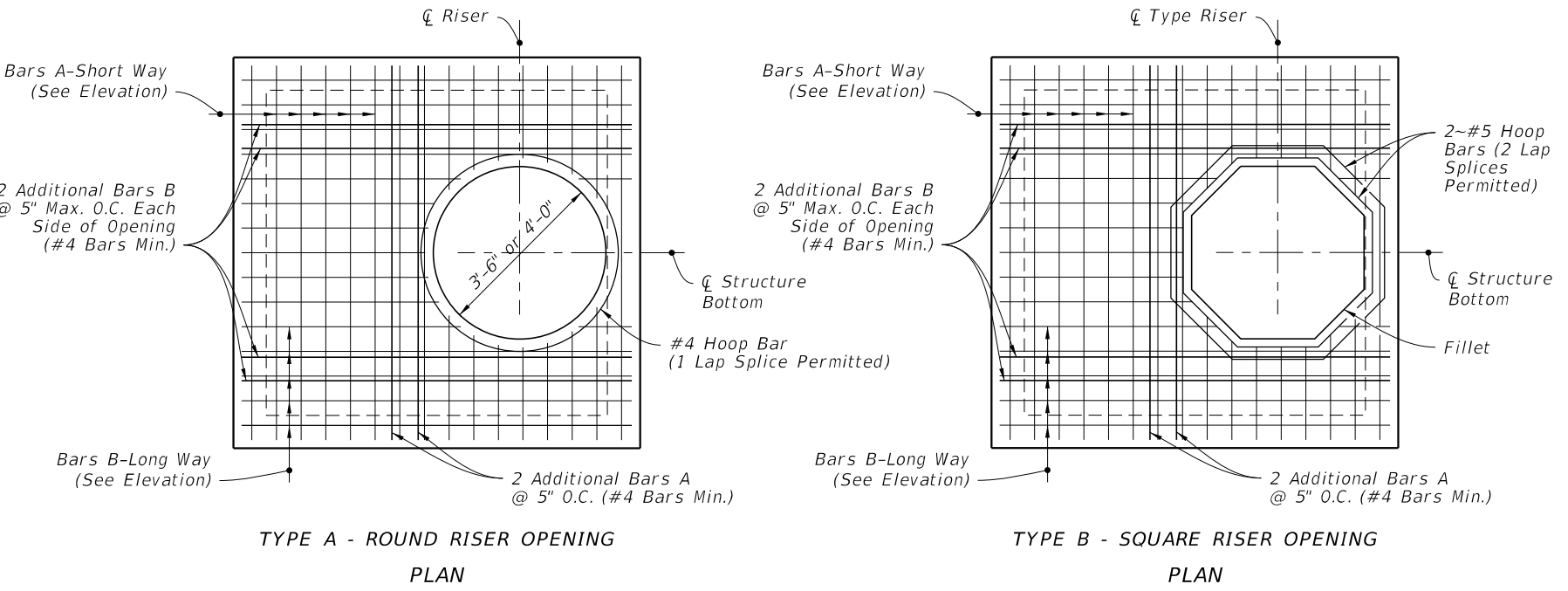
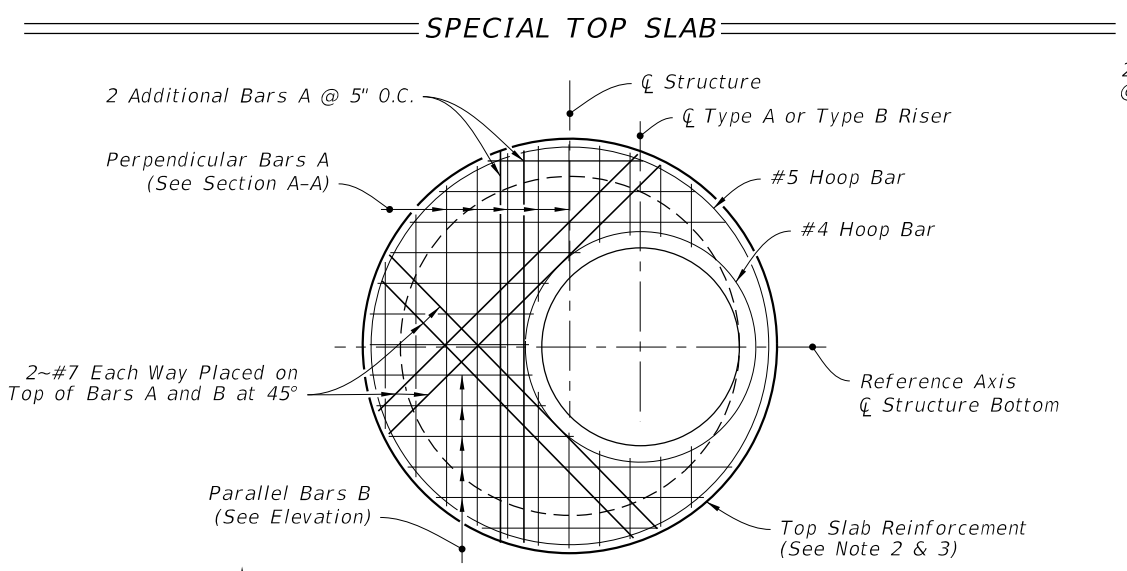

TYPE J BOTTOM - ALTERNATE A

TYPE J BOTTOM - ALTERNATE B

DIMENSIONAL AND REINFORCING DETAILS

10/13/2025 2:52:06 PM

LAST REVISION 11/01/20	DESCRIPTION:		FY 2026-27 STANDARD PLANS	STRUCTURE BOTTOMS TYPE J AND P	INDEX 425-010	SHEET 2 of 4
---------------------------	--------------	--	------------------------------	--------------------------------	------------------	-----------------

TABLE 1 - ALTERNATE A - STRUCTURES

TYPE	STRUCTURE/RISER DIAMETER (ft)	CAST-IN-PLACE ITEMS CLASS II CONCRETE			PRECAST ITEMS				
					CLASS II CONCRETE			ASTM C478	
		t ₁ RISER (in.)	t ₂ BOTTOM (in.)	A _s (in ² /ft.)	t ₁ RISER (in.)	t ₂ BOTTOM (in.)	A _s (in ² /ft.)	t ₁ or t ₂ (in.)	A ₂ ** (in ² /ft.)
P	3'-6"	6	8	0.20	6	8	0.20	4**	0.105
P	4'-0"	6	8	0.20	6	8	0.20	5**	0.120
J	5'-0"	-	8	0.20	-	8	0.20	6**	0.150
J	6'-0"	-	8	0.20	-	8	0.20	6	0.180
J	7'-0"	-	8	0.20	-	8	0.20	7	0.210
J	8'-0"	-	8	0.20	-	8	0.20	8	0.240
J	10'-0"	-	10	0.40##	-	10	0.40##	10	0.300
J	12'-0"	-	10	0.40##	-	12	0.40##	12	0.360

t₁ and t₂ - Wall Thickness.

A_s - Vertical and horizontal areas of reinforcement.

Provide 0.20 eq. in²/ft. at each face, 12" max. bar spacing.

**Modified minimum wall thickness.

***Min. total circumferential reinforcement for continuous steel hoops:

A₂ = 0.40 sq. in. for riser section height equal or less than 2'-0" (2 hoop min.)

A₂ = 0.60 sq. in. for riser section height more than 2'-0" up to 4'-0" (3 hoop min.)

Areas of reinforcing for precast items are based on Grade 60 reinforcing.

No reduction in the area of reinforcement is allowed for welded wire fabric in Table 1.

Area of vertical reinforcing may be reduced in accordance with ASTM C478.

TABLE 3 - REINFORCING SCHEDULE

SCHEDULE	GRADE 60 BARS OR 65 KSI & 70 KSI WELDED WIRE REINFORCING			
	GRADE 60 AREA (in ² /ft)	MAXIMUM SPACING		
		GR 60 BARS (in.)	65 KSI (in.)	70 KSI (in.)
A12	0.20	12	8	8
A6	0.20	6	5	4½
B10	0.24	10	8	7½
B5.5	0.24	5½	5	4
C6.5	0.37	6½	6	5
C3.5	0.37	3½	3	2½
D7	0.53	7	6	5
D4.5	0.53	4½	4	3½
E5	0.73	5	4	4
E3	0.73	3	3	3
F5	1.06	5	4	4
F3.5	1.06	3½	3	3
G5	1.45	5	4	4
G.3.5	1.45	3½	3	3
H4	1.75	4	3	3

TABLE 2 - ALTERNATE B SQUARE AND RECTANGULAR STRUCTURES

TYPE	WALL LENGTH (FT)	MAX. DEPTH (FT)	WALL THICKNESS (t ₃)	
			C-I-P (in.)	PRECAST (in.)
			P	≤ 3'-6"
J	4'-0"	40	8	6
J	5'-0"	22	-	6
J	6'-0"	15	-	6
J	5'-0" to 9'-0"	40	8	8
J	10'-0"	26	8	8
J	10'-0" to 12'-0"	40	10	9
J	16'-0"	35	-	9
J	16'-0"	40	10	10
J	20'-0"	25	-	9
J	20'-0"	30	10	10

See Table 4 for Reinforcing Schedule.

TABLE 4 - WALL DESIGNS - RECTANGULAR STRUCTURES

VERTICAL REINFORCING		HORIZONTAL REINFORCING		WALL THICKNESS		
WALL DEPTH	SCHEDULE	WALL DEPTH	SCHEDULE			
SIZE: 3'-6" & RISER						
≥1.17' - 40'	A12	≥1.17' < 10'	B10	6"/8"		
		10' < 18'	B5.5	6"/8"		
		18' < 29'	C6.5	6"/8"		
		29' - 40'	C3.5	6"/8"		
SIZE: 4'-0"						
≥1.17' - 40'	A12	≥1.17' < 6'	B10	6"/8"		
		6' < 10'	B5.5	6"/8"		
		10' < 20'	C6.5	6"/8"		
		20' < 28'	C3.5	6"/8"		
		28' - 40'	D4.5	6"/8"		
SIZE: 5'-0"						
≥1.17' - 40'	A12	≥1.17' < 5'	B5.5	6"/8"		
		5' < 9'	C6.5	6"/8"		
		9' < 15'	C3.5	6"/8"		
		15' < 22'	D4.5	6"/8"		
		22' - 40'	E3	8"		
SIZE: 6'-0"						
≥1.17' < 26'	A12	≥1.17' < 9'	C3.5	6"/8"		
		9' < 15'	D4.5	6"/8"		
		15' < 26'	E3	8"		
	Inside/Outside		Inside/Outside			
26' - 40'	A12	A12	26' - 40'	D7	D7	8"
SIZE: 7'-0"						
	Inside/Outside		Inside/Outside			
≥1.17' < 25'	A12	A12	≥1.17' < 7'	B10	B10	8"
26' - 40'	B10	B10	7' < 10'	B5.5	B5.5	8"
			10' < 20'	C6.5	C6.5	8"
			20' < 30'	D7	D7	8"
			30' - 40'	E5	E5	8"
SIZE: 8'-0"						
	Inside/Outside		Inside/Outside			
≥1.17' < 20'	A12	A12	≥1.17' < 6'	B5.5	B5.5	8"
20' - 40'	C6.5	C6.5	6' < 13'	C6.5	C6.5	8"
			13' < 22'	D7	D7	8"
			22' < 31'	E5	E5	8"
			31' - 40'	F5	F5	8"
SIZE: 9'-0"						
	Inside/Outside		Inside/Outside			
≥1.17' < 12'	A12	A12	≥1.17' < 8'	C6.5	C6.5	8"
12' < 28'	C6.5	C6.5	8' < 15'	D7	D7	8"
28' - 40'	D7	D7	15' < 23'	E5	E5	8"
			23' - 40'	F5	F5	8"
SIZE: 10'-0"						
	Inside/Outside		Inside/Outside			
≥1.17' < 10'	B10	B10	≥1.17' < 10'	D7	D7	8"
10' < 21'	C6.5	C6.5	10' < 17'	E5	E5	8"
21' < 26'	D7	D7	17' < 26'	F5	F5	8"
26' - 40'	C6.5	C6.5	26' - 40'	F5	F5	10"
SIZE: 10'-0" (Precast Only)						
	Inside/Outside		Inside/Outside			
26' - 40'	D7	D7	26' - 40'	F5	F5	9"
SIZE: 12'-0"						
	Inside/Outside		Inside/Outside			
≥1.17' < 14'	B10	B10	≥1.17' < 10'	C6.5	C6.5	10"
14' < 25'	C6.5	C6.5	10' < 17'	D7	D7	10"
25' - 40'	D7	D7	17' < 24'	E5	E5	10"
			24' - 40'	F5	F5	10"
SIZE: 12'-0" (Precast Only)						
	Inside/Outside		Inside/Outside			
≥1.17' < 12'	B10	B10	≥1.17' < 10'	D7	D7	9"
12' < 24'	C6.5	C6.5	10' < 17'	D4.5	D4.5	9"
24' - 40'	D7	D7	17' < 23'	E5	E5	9"
			23' < 32'	F5	F5	9"
			32' - 40'	G5	G5	9"
SIZE: 16'-0"						
	Inside/Outside		Inside/Outside			
≥1.17' < 11'	C6.5	C6.5	≥1.17' < 13'	D7	D7	10"
11' < 20'	D7	D7	13' < 20'	E5	E5	10"
20' < 28'	E5	E5	20' < 28'	F5	F5	10"
28' - 40'	F5	F5	28' - 40'	G5	G5	10"
SIZE: 16'-0" (Precast Only)						
	Inside/Outside		Inside/Outside			
≥1.17' < 10'	C6.5	C6.5	≥1.17' < 9'	D7	D7	9"
10' < 18'	D7	D7	9' < 13'	D4.5	D4.5	9"
18' < 25'	E5	E5	13' < 19'	E5	E5	9"
25' - 35'	F5	F5	19' < 27'	F5	F5	9"
			27' - 35'	G5	G5	9"
SIZE: 20'-0"						
	Inside/Outside		Inside/Outside			
≥1.17' < 10'	C6.5	C6.5	≥1.17' < 8'	D7	D7	10"
10' < 17'	D7	D7	8' < 12'	E5	E5	10"
17' - 30'	E5	E5	12' < 20'	F5	F5	10"
			20' - 30'	G5	G5	10"
SIZE: 20'-0" (Precast Only)						
	Inside/Outside		Inside/Outside			
≥1.17' < 8'	C6.5	C6.5	≥1.17' < 8'	D4.5	D4.5	9"
8' < 13'	D7	D7	8' < 12'	E5	E5	9"
13' - 25'	E5	E5	12' < 19'	F5	F5	9"
			19' - 25'	G5	G5	9"

TABLE 4 NOTES:

1. Wall depth is measured to the top of the bottom slab for boxes and to the top of the intermediate slab for risers.
2. Wall height is the distance between top of lower slab to bottom of upper slab. Maximum wall height is 12' for wall lengths exceeding 5', or 10' for wall lengths exceeding 12'.
3. Wall lengths exceeding 6'-0" require two layers of reinforcing (See Table 4) with 2" of cover from the horizontal bars to the inside and outside faces for each layer.
4. Wall lengths exceeding the dimensions or depths shown in Table 4, or 12'-0" diameter require a special design.
5. Wall thickness and reinforcing for rectangular structures is based on the longer wall length.

TABLES 1, 2, 3, AND 4

9/26/2025 11:47:08 AM

TABLE 5 - SLAB DESIGNS - SQUARE AND RECTANGULAR STRUCTURES
(ALL SLABS 8" THICK EXCEPT AS NOTED - REINFORCING PARALLEL TO SHORT WAY AND LONG WAY)

SHORT-WAY		LONG-WAY		SHORT-WAY		LONG-WAY		SHORT-WAY		LONG-WAY	
SLAB DEPTH	SCHEDULE (Bars A)	SLAB DEPTH	SCHEDULE (Bars B)	SLAB DEPTH	SCHEDULE (Bars A)	SLAB DEPTH	SCHEDULE (Bars B)	SLAB DEPTH	SCHEDULE (Bars A)	SLAB DEPTH	SCHEDULE (Bars B)
SIZE: 3'-6" x UNLIMITED				SIZE: 6' x 6'				SIZE: 8' x 8'			
≥0.5' < 8'	B10	≥0.5' < 24'	B10	≥0.5' < 13'	C6.5	≥0.5' < 10'	C3.5	≥0.5' < 10'	D7	≥0.5' < 9'	D4.5
8' < 13'	B5.5	24'-40'	B5.5	13' < 23'	D7	10' < 18'	D4.5	10' < 19'	E5	9' < 13'	E5
13' < 31'	C6.5			23'-40'	E5	18' < 27'	E5	19'-30'	F5	13' < 18'	F5
31'-40'	D7					27' < 33'	E3			18' < 23'	F3.5
						33'-40'	F5			23'-30'	G3.5
SIZE: 4' x UNLIMITED				SIZE: 6' x 7'				SIZE: 8' x 9'			
≥0.5' < 7'	B5.5	≥0.5' < 15'	B10	≥0.5' < 8'	C6.5	≥0.5' < 8'	C6.5	≥0.5' < 8'	D7	≥0.5' < 7'	D7
7' < 19'	C6.5	15' < 29'	B5.5	8' < 16'	D7	8' < 12'	C3.5	8' < 14'	E5	7' < 9'	D4.5
19' < 31'	D7	29'-40'	C6.5	16' < 28'	E5	12' < 21'	D4.5	14' < 23'	F5	9' < 15'	E3
31'-40'	E5			28'-40'	F5	21' < 28'	E5	23'-31'	G3.5	15' < 20'	F5
						28' < 35'	E3			20' < 23'	F3.5
						35'-40'	F5			23'-31'	G3.5
SIZE: 5' x 5'				SIZE: 6' x 8'				SIZE: 9' x 9'			
≥0.5' < 3'	C6.5	≥0.5' < 3'	C6.5	≥0.5' < 6'	C6.5	≥0.5' < 6'	B5.5	≥0.5' < 8'	D7	≥0.5' < 7'	D4
3' < 7'	B5.5	3' < 13'	C6.5	6' < 13'	D7	6' < 11'	C6.5	8' < 14'	E5	7' < 10'	E5
7' < 22'	C6.5	13' < 22'	D7	13' < 22'	E5	11' < 17'	C3.5	14' < 22'	F5	10' < 17'	F3.5
22' < 29'	D7	22' < 29'	D4.5	22' < 35'	F5	17' < 22'	D4.5	17' < 22'	G3.5	17' < 22'	G3.5
29'-40'	E5	29'-40'	E5	35'-40'	G5	22' < 32'	E5			17' < 22'	G3.5
						32'-40'	E3	SIZE: 9'x9'x10" SLAB THICKNESS			
SIZE: 5' x 6'				SIZE: 6' x 9'				SIZE: 10'x10'x10" SLAB THICKNESS			
≥0.5' < 12'	C6.5	≥0.5' < 3'	C6.5	≥0.5' < 8'	D7	≥0.5' < 8'	B5.5	22' < 36'	F5	22' < 31'	F3.5
12' < 26'	D7	3' < 9'	B5.5	8' < 14'	E5	8' < 14'	C6.5	36'-40'	G5	31'-40'	G3.5
26'-40'	E5	9' < 23'	C3.5	14' < 24'	F5	14' < 21'	C3.5	SIZE: 12'x12'x12" SLAB THICKNESS			
		23' < 35'	D4.5	24'-34'	G5	21' < 25'	D4.5	≥0.5' < 7'	C6.5	0.5' < 6'	C6.5
		35'-40'	E5			25'-34'	E5	7' < 10'	D7	6' < 9'	D4.5
SIZE: 5' x 7'				SIZE: 6' x UNLIMITED				SIZE: 10'x10'x10" SLAB THICKNESS			
≥0.5' < 10'	C6.5	≥0.5' < 10'	B5.5	≥0.5' < 8'	D7	≥0.5' < 8'	B5.5	10' < 18'	E5	9' < 15'	E5
10' < 20'	D7	10' < 31'	C3.5	8' < 14'	E5	8' < 14'	C6.5	18' < 27'	F5	15' < 22'	F5
20' < 34'	E5	31'-40'	D4.5	14' < 24'	F5	14' < 21'	C3.5	27'-32'	G5	22'-32'	G3.5
34'-40'	F5			24'-34'	G5	21' < 25'	D4.5	SIZE: 12'x12'x12" SLAB THICKNESS			
						25'-34'	E5	≥0.5' < 10'	D7	≥0.5' < 8'	D7
SIZE: 5' x 8'				SIZE: 7' x 7'				SIZE: 12'x12'x12" SLAB THICKNESS			
≥0.5' < 7'	C6.5	≥0.5' < 8'	B10	≥0.5' < 8'	D7	≥0.5' < 8'	B5.5	10' < 16'	E5	8' < 14'	E5
7' < 13'	D7	8' < 17'	B5.5	8' < 14'	E5	8' < 14'	C6.5	16' < 25'	F5	14' < 22'	F5
13' < 24'	E5	17' < 25'	C6.5	14' < 24'	F5	14' < 21'	C3.5	25'-35'	G5	22' < 30'	G5
24'-40'	F5	25'-40'	C3.5	24'-34'	G5	21' < 25'	D4.5			30'-35'	H4
						25'-34'	E5	SIZE: 9' x 9'			
SIZE: 5' x 9'				SIZE: 7' x 9'				SIZE: 10' x 10'			
≥0.5' < 8'	C6.5	≥0.5' < 14'	B10	≥0.5' < 8'	D7	≥0.5' < 4'	C6.5	≥0.5' < 7'	C6.5	≥0.5' < 7'	C6.5
8' < 14'	D7	14' < 24'	B5.5	8' < 15'	D7	4' < 7'	C3.5	9' < 15'	E5	7' < 10'	C3.5
14' < 25'	E5	24' < 34'	C6.5	15' < 26'	E5	7' < 11'	D4.5	11' < 19'	E5	5' < 8'	C3.5
25'-40'	F5	34'-40'	C3.5	26'-40'	F5	11' < 22'	E3	19' < 30'	F5	8' < 13'	D4.5
						22' < 32'	F3.5	30'-40'	G5	22' < 30'	F3.5
						32'-40'	G3.5			30'-40'	G3.5
SIZE: 5' x UNLIMITED				SIZE: 7' x 8'				SIZE: 10' x 10'			
≥0.5' < 8'	C6.5	≥0.5' < 14'	B10	≥0.5' < 5'	C6.5	≥0.5' < 5'	C6.5	≥0.5' < 9'	D7	≥0.5' < 7'	C6.5
8' < 14'	D7	14' < 24'	B5.5	5' < 11'	D7	5' < 8'	C3.5	9' < 15'	E5	7' < 10'	C3.5
14' < 25'	E5	24' < 34'	C6.5	11' < 19'	E5	8' < 13'	D4.5	15' < 25'	F5	10' < 14'	D4.5
25'-40'	F5	34'-40'	C3.5	19' < 30'	F5	13' < 22'	E3	25' - 34'	G5	14' < 21'	E5
				30'-40'	G5	22' < 30'	F3.5			21' < 29'	F5
						30'-40'	G3.5			29'-34'	F3.5

TABLE 6 - SLAB DESIGNS ROUND STRUCTURES

SLAB DEPTH	SLAB THICKNESS	REINF. (2-WAY) SCHEDULE
SIZE: 3'-6" DIAMETER		
2'-15'	6" Precast	C6.5
0.5' < 30'	8"	A6
30'-40'	8"	B5.5
SIZE: 4'-0" DIAMETER		
≥0.5' < 19'	8"	A6
19' < 30'	8"	B5.5
30'-40'	8"	C6.5
SIZE: 5'-0" DIAMETER		
≥0.5' < 15'	8"	B5.5
15' < 26'	8"	C6.5
26' < 35'	8"	D7
35'-40'	8"	D4.5
SIZE: 6'-0" DIAMETER		
≥0.5' < 9'	8"	B5.5
9' < 15'	8"	C6.5
15' < 22'	8"	C3.5
22' < 30'	8"	D4.5
30'-40'	8"	E5
SIZE: 7'-0" DIAMETER		
≥0.5' < 8'	8"	C3.5
8' < 16'	8"	D4.5
16' < 23'	8"	E5
23' < 27'	8"	E3
27'-40'	8"	F3.5
SIZE: 8'-0" DIAMETER		
≥0.5' < 10'	8"	D4.5
10' < 16'	8"	E5
16' < 19'	8"	E3
19' < 29'	8"	F3.5
29'-40'	10"	F5
SIZE: 10'-0" DIAMETER		
≥0.5' < 12'	10"	D4.5
12' < 20'	10"	E5
20' < 28'	10"	F5
28'-40'	10"	G3.5
SIZE: 12'-0" DIAMETER		
≥0.5' < 8'	10"	D4.5
8' < 13'	10"	E5
13' < 18'	10"	F5
18' < 26'	10"	G3.5
26'-40'	12"	G3.5

SLAB AND WALL DESIGN TABLE NOTES

1. Size is the inside dimension(s) of a structure.
2. Slab reinforcement is appropriate for top, intermediate, and bottom slabs.
3. Bottom Slabs for precast 3'-6" x 3'-6" rectangular structures at 15' depth or less, may be 6" thick.
4. Slab depth is measured from finished grade to top of slab.
5. Reinforcing schedules with larger areas of steel may be substituted for schedules with smaller bar or wire spacing, except that Schedule B10 may not be substituted for Schedule A6. See Index 425-001 for allowable bar spacing adjustments when larger areas of reinforcing are substituted.

9/26/2025 11:47:15 AM

LAST REVISION 11/01/20

REVISION DESCRIPTION:



FY 2026-27
STANDARD PLANS

STRUCTURE BOTTOMS TYPE J AND P

TABLES 5 AND 6

INDEX
425-010

SHEET
4 of 4