

KEYWAY & WALL JOINT DETAIL (TOP VIEW)

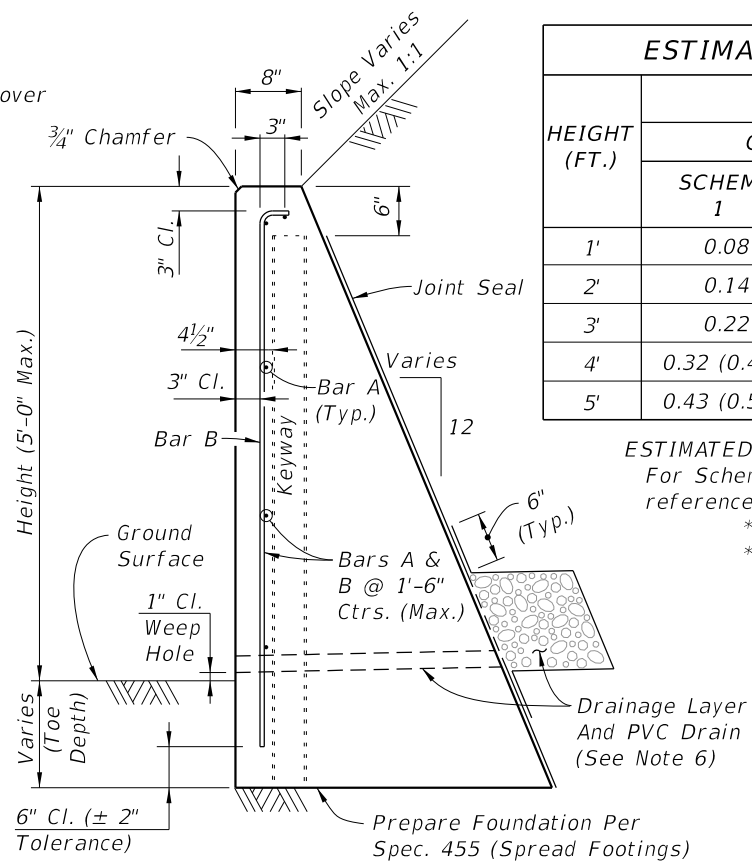

TYPICAL SECTION C-I-P CONCRETE GRAVITY WALL

HEIGHT (FT.)	PER LINEAR FOOT OF WALL			WEEP HOLES & DRAIN REQD.
	CLASS NS CONCRETE (CY)			
	SCHEME 1	SCHEME 2	SCHEME 3**	
1'	0.08	0.11 (0.20*)	0.03	3 (4*) No
2'	0.14	0.20 (0.32*)	0.09	4 (5*) No
3'	0.22	0.32 (0.47*)	0.29	5 (6*) Yes
4'	0.32 (0.43*)	0.47 (0.65*)	0.43	6 (7*) Yes
5'	0.43 (0.55*)	0.65 (0.85*)	0.60	7 (8*) Yes

ESTIMATED QUANTITIES NOTES:
 For Scheme 3 Junction Slab and Traffic Railing see the referenced Index for estimated quantities.
 * Quantity for 2'-0" Toe Depth.
 ** Quantity for Scheme 3 assumes 1'-3" thick coping above Gravity Wall.

GENERAL NOTES

- C-I-P Gravity Walls constructed as extensions of reinforced concrete retaining walls, except for walls of proprietary designs, provide the same face texture and finish as the reinforced concrete retaining wall.
- Use Class NS Concrete for Gravity Wall per Specification 347. Concrete for Scheme 3 Junction Slab and Traffic Railing shall be Class II per Specification 346, unless otherwise specified in the plans.
- Reinforcing steel meets the requirements of Specification 931 (Grade 40 or 60). Smooth or Deformed Welded Wire Reinforcement (WWR) may be substituted on an equal area basis. Do not increase bar/wire spacing for Grade 60 reinforcing steel or WWR.
- When required, for adjunct guiderail, see Index 515-070 or 515-080 as appropriate. For adjunct Type B fence see Index 550-002.
- Joint Seal: Provide and install organic bond breaker or Type D-5 geotextile in accordance with Specifications 400 and 514 respectively. Mop all contact surfaces of concrete and Organic Felt or geotextile with cut-back asphalt. Stop Organic Felt or geotextile 6" below top of wall.
- Provide a continuous 1'x1' clean gravel or crushed rock drain for wall heights 3 ft. and higher. Wrap drainage layer as shown, with Type D-3 geotextile in accordance with Specification 514. Provide 8"x8" galvanized mesh with 1/4" openings, at the inside end of the PVC Drain Pipe. Provide 2" Ø PVC Drain Pipe (Sch. 40) at 10 ft. max. spacing (when Drainage Layer is required). Locate outermost edge of Drain Pipe a minimum of 2'-0" from wall joints.
- Cost of reinforcing steel, face texture, finish, joint seal, drain pipes, drainage layer, galvanized mesh and geotextile to be included in the Contract Unit Price for Concrete Class NS, Gravity Wall. Cost of concrete for Junction Slab in Scheme 3, to be included in Contract Unit Price for Concrete Traffic Railing Barrier With Junction Slab. Adjunct railings or fences to be paid for separately.

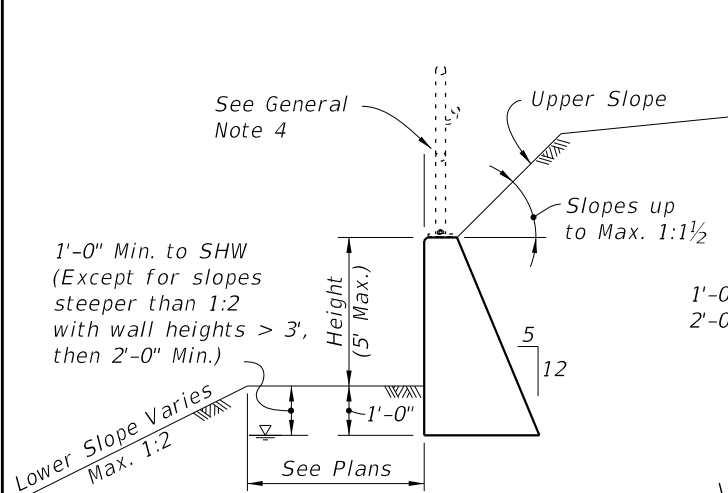

SCHEME 1 (No Traffic Loading Effects & Upper Slopes ≤ 1:1½)

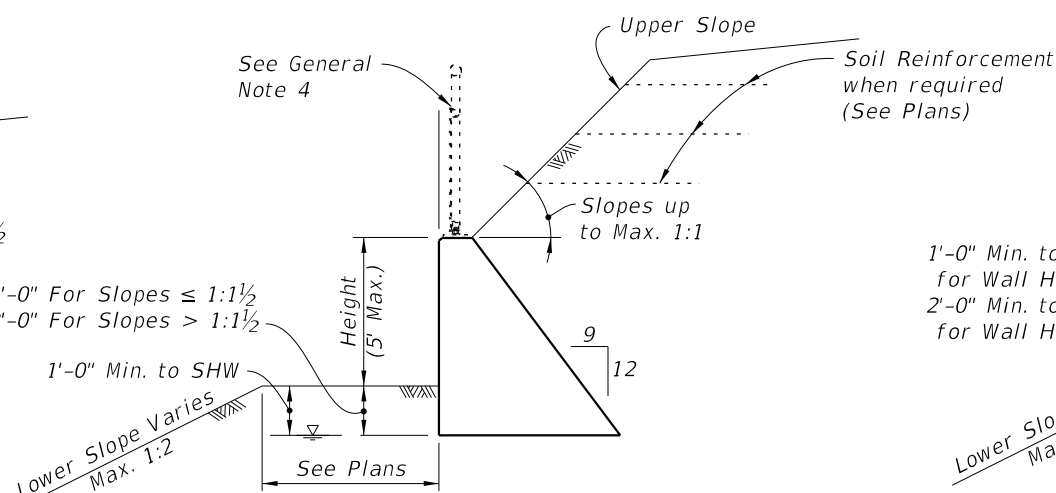

SCHEME 2 (With Traffic Loading or Upper Slopes > 1:1½)

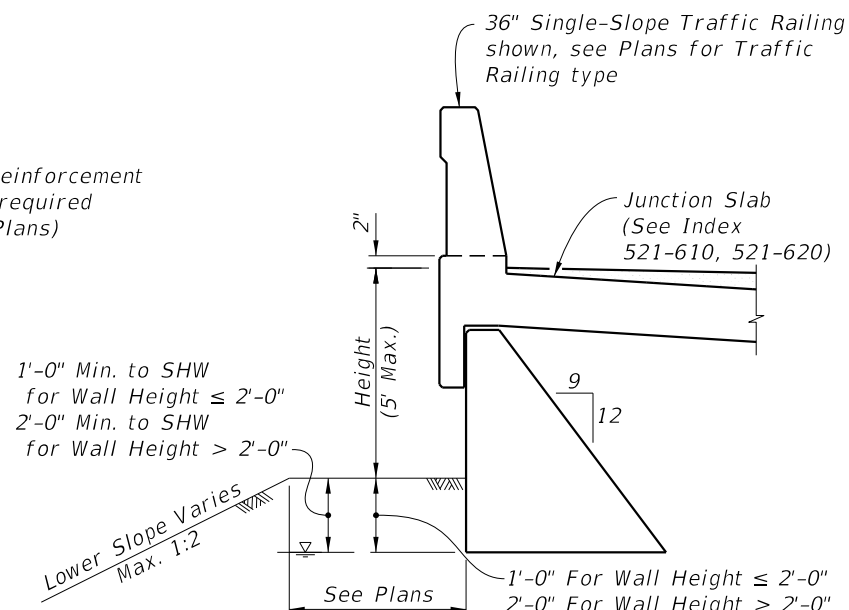

SCHEME 3 (With Traffic Railing)

BILL OF REINFORCING STEEL		
MARK	SIZE	LENGTH
A	4	As Reqd.
B	4	As Reqd.

BAR BENDING DIAGRAM

BAR A: Wall joint spacing - 4" (29'-8" Max.), 4 1/2" offset, 1" R offset.

BAR B: Height + Toe Depth - 9", Height + Toe Depth - 2'-0", 9" offset, 12" offset.

NOTES:
 1. All bar dimensions are out to out.
 2. Lap splices for Bars A must be a minimum of 1'-10".

9/26/2025 11:44:51 AM