

GENERAL NOTES:

1. Meet the requirements of Specification 700.
2. Verify Column lengths in the field prior to fabrication.
3. Shop drawings:
 - A. Sign Support Shop drawings are not required when fabricated in accordance with this Index and support columns do not exceed the width ("W") shown in the plans by more than 2'-0".
 - B. Sign Panels: Horizontal panel splices are allowed at interior wind beams for sign panels with a height ("H") greater than 10 feet. Shop drawings required for horizontal panel splice details.
 - C. When shop drawings are required, obtain approval prior to fabrication.
4. Materials:
 - A. Sign Panel Mounting Materials:
 - a. Aluminum Bars, and Extruded Shapes: ASTM B221, Alloy 6061-T6 or Alloy 6351-T5
 - b. Aluminum Structural Shapes: ASTM B221, Alloy 6061-T6
 - B. Sign Support Structure Materials:
 - a. Steel Plates and Structural Shapes: ASTM A36 or ASTM A709, Grade 36
 - b. Steel Weld Metal: E70XX
 - c. Shims: Brass ASTM B36 or Galvanized Steel
 - C. Aluminum Bolts, Nuts and Washers:
 - a. Flat Head and Button Head Bolts: ASTM F 468, Alloy 2024-T4
 - b. Hex Nuts: ASTM F467, 2024-T4
 - c. Washers: ASTM B221, Alloy 2024-T4
 - D. Stainless Steel Bolts, Nuts and Washers Alloy Group 2, Condition A, may be substituted for the Aluminum bolts as follows:
 - a. Bolts: ASTM F593, CW1 or SH1
 - b. Nuts: ASTM F594,
 - E. High Strength (H.S.) Steel Bolts, Nuts and Washers:
 - a. Galvanized Hex Head Bolts: ASTM F3125, Grade A325, Type 1
 - b. Galvanized Nuts: ASTM A563 Hex, Grade DH
 - c. Galvanized Washers: ASTM F436
 - F. Concrete: Class II.

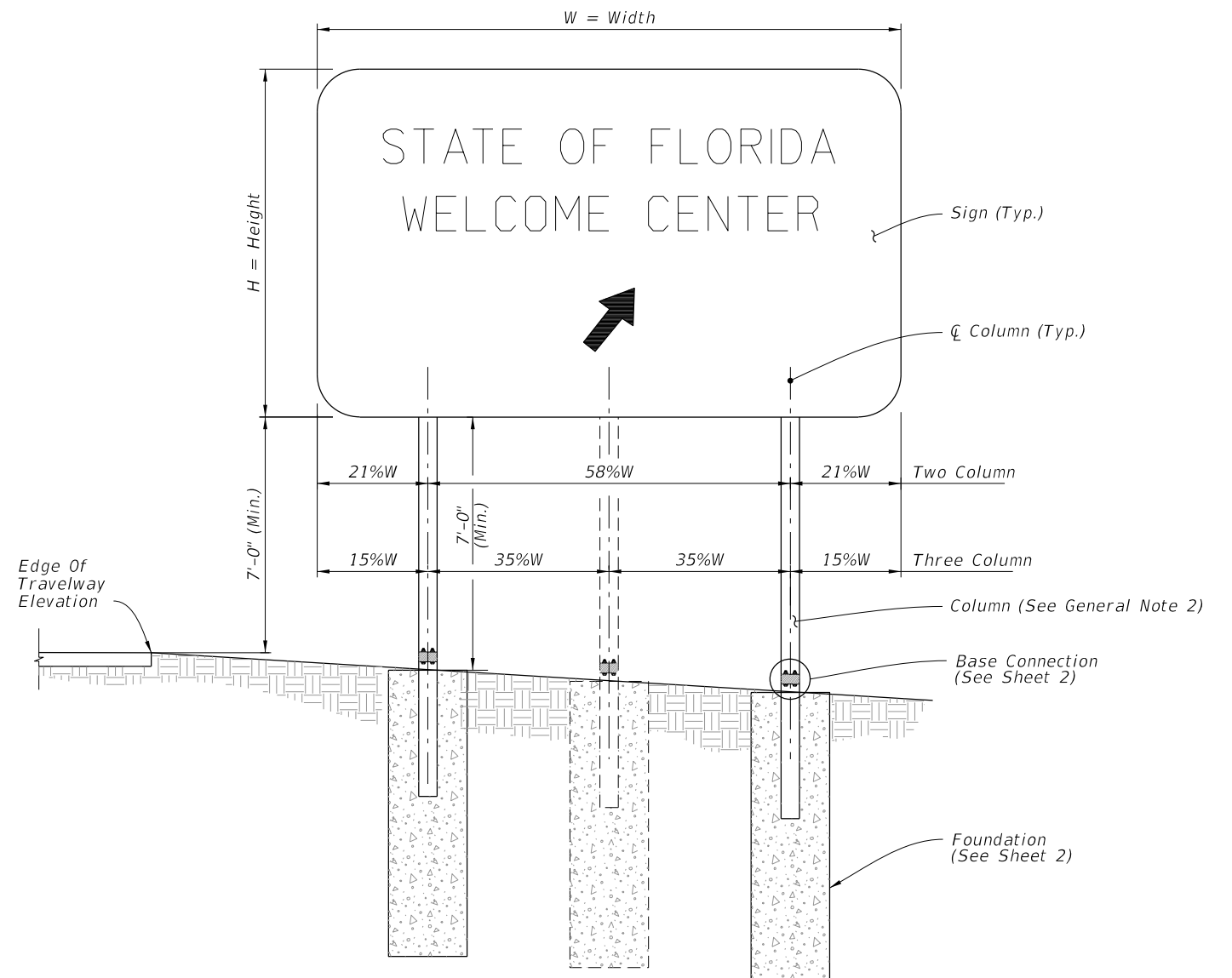

FRONT ELEVATION

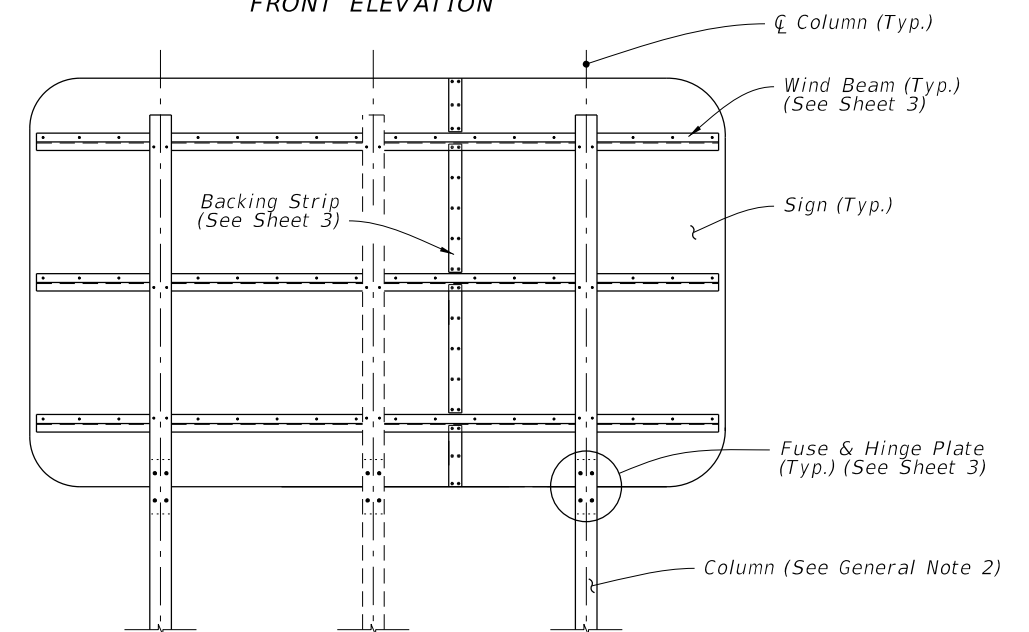

BACK ELEVATION

MULTI-COLUMN SIGN ASSEMBLY

9/10/2024 2:43:24 PM

LAST REVISION 11/01/23	REVISION	DESCRIPTION:		FY 2025-26 STANDARD PLANS	MULTI-COLUMN GROUND SIGN	INDEX 700-020	SHEET 1 of 3
---------------------------	----------	--------------	---	------------------------------	--------------------------	------------------	-----------------

STATE OF FLORIDA
WELCOME CENTER

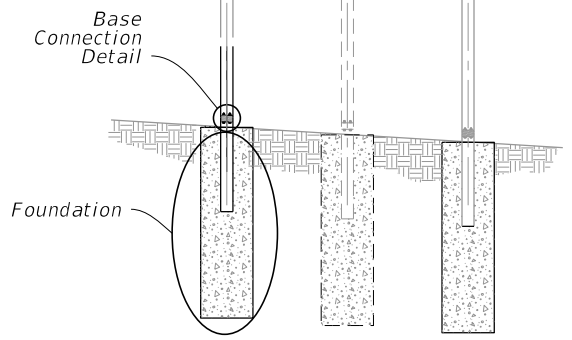

FOUNDATION DATA				
Steel Post & Stub Section*	Dia.	Depth	Stub Column Length	Reinf. Bars V
S 3x5.7	2'-0"	4'-0"	3'-0"	10-#6
W 6x12	2'-0"	6'-0"	3'-0"	10-#6
W 8x18	2'-4"	7'-6"	4'-0"	8-#8
W 8x24	2'-4"	8'-6"	4'-0"	8-#8
W 10x33	2'-4"	10'-3"	4'-0"	8-#8
W 12x45	2'-8"	11'-3"	5'-0"	10-#8

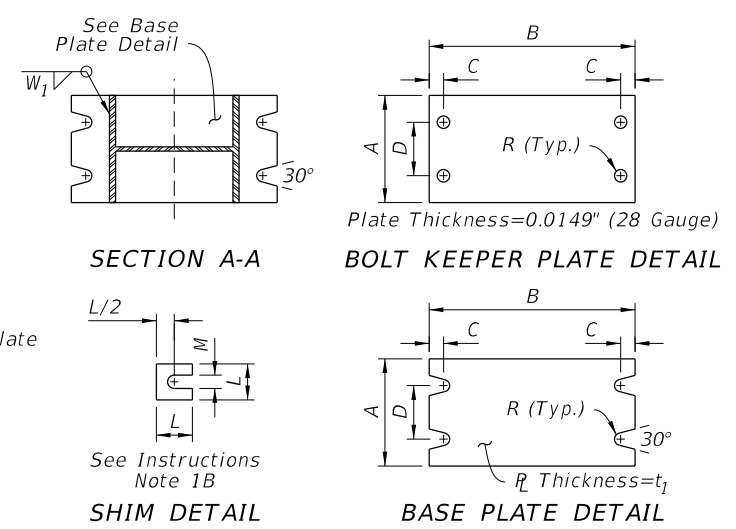
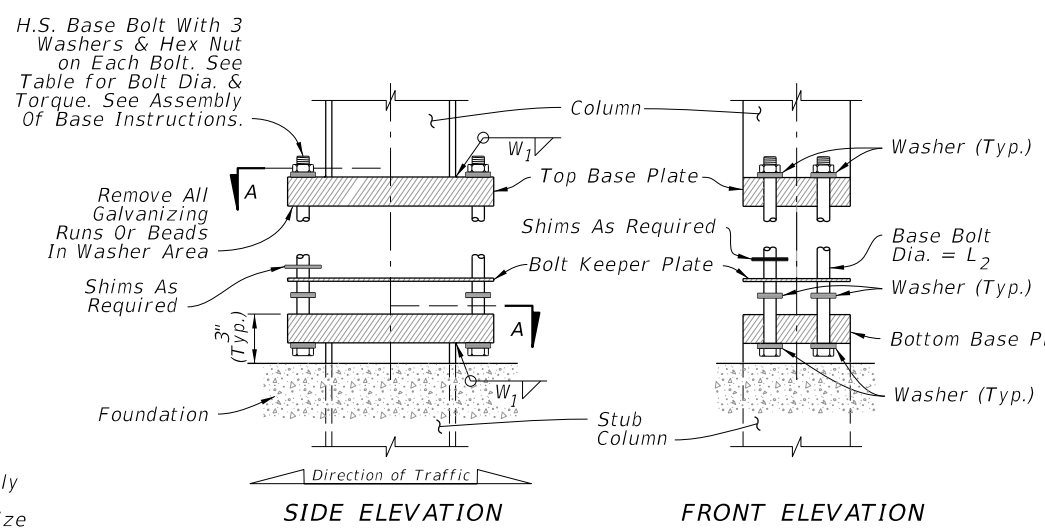
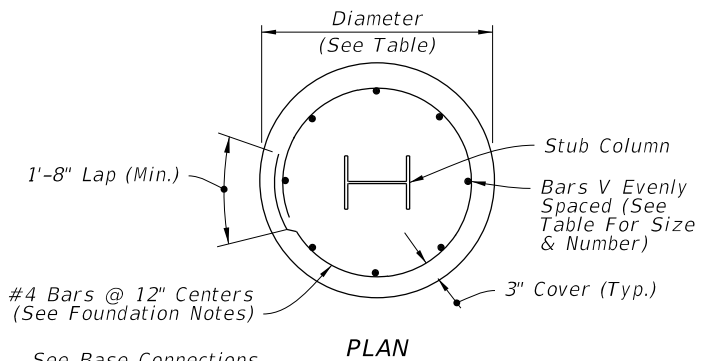

MULTI-COLUMN SIGN ASSEMBLY

FOUNDATION NOTES:

The foundation may be either precast or cast-in-place. Use Reinforcing bars or equivalent Welded Wire Reinforcement.

At the Contractor's option, the #4 tie bars at 12" o.c. may be replaced by D10 Spiral Wire @ 6" pitch, with three flat turns at the top and one flat turn at the bottom in accordance with Specification 415.

For precast foundations, the circular cross section shown may be substituted with an octagon shape. The out-to-out distance between parallel edges must be greater than or equal to the diameter in the Foundation Data table. Use the same reinforcing diameter with centered placement and a minimum 3" cover.

BASE CONNECTION NOTES:

- Assembly of Base Instructions:
 - Place one washer on each Base Bolt between the Bottom Base Plate and the head of high strength Base Bolt; place the next washer between the Bottom Base Plate and the Bolt Keeper Plate; add the Top Base Plate section and place the third washer between the Top Base Plate and the Nut.
 - Shim as required to plumb column. Provide 2-0.0149" thick (28 gauge) and 2-0.0329" thick (21 gauge) shims per column.
- H.S. Base Bolt L Tightening Instructions:
 - Tighten Base Bolts to the maximum possible with a 12" to 15" wrench (this will bed the washers and shims and clear the bolt threads).
 - Loosen each Base Bolt one turn.
 - Under the supervision of the Engineer, use a calibrated wrench to tighten bolts to the torque prescribed in the Table. Over tightened Base Bolts will not be permitted.
 - Burr threads at junction with nut to prevent nut loosening. Treat damaged galvanizing.
- Assemble Post to Stub with Base Bolts and three flat washers per bolt (See Base Connection Details). Tighten Base Bolts in accordance with Instructions with Note 2.
- Weld Base Plate to Post & Stub or if using the Alternate Connection Detail weld Base Plate and Stiffeners to Post and Stub.
- Orient Stub Post according to direction of traffic.

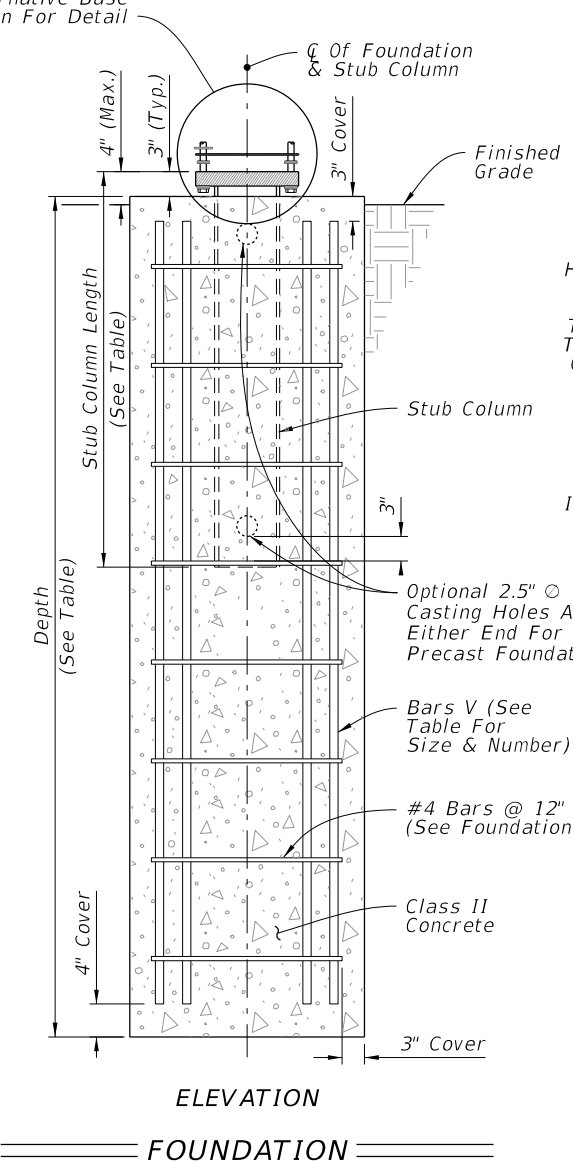

Steel Post & Stub Section*	BASE CONNECTION DATA								SHIM		
	A	B	C	D	R	t ₁	L ₂	W ₁	Torque (lbf*in)	L	M
S 3x5.7	4"	7"	3/4"	2"	5/16"	1"	1/2"	1/4"	90 ± 20	1-1/4"	9/16"
W 6x12	4"	10"	3/4"	2"	3/8"	1-5/8"	5/8"	1/4"	270 ± 45	1-3/8"	11/16"
W 8x18	5-1/4"	12-1/2"	7/8"	2-3/4"	7/16"	1-3/4"	3/4"	3/8"	445 ± 75	1-3/4"	13/16"
W 8x24	6-1/2"	12-1/2"	7/8"	3-1/4"	7/16"	1-3/4"	3/4"	3/8"	445 ± 75	2-1/8"	13/16"
W 10x33	8"	16"	1-1/4"	4-3/4"	9/16"	2"	1"	1/2"	580 ± 90	2-3/8"	1-1/16"
W 12x45	10"	18"	1-1/4"	6"	9/16"	2"	1"	1/2"	580 ± 90	2-3/4"	1-1/16"

* Designations: (Nominal Depth in inches) x (weight in pounds per linear foot).

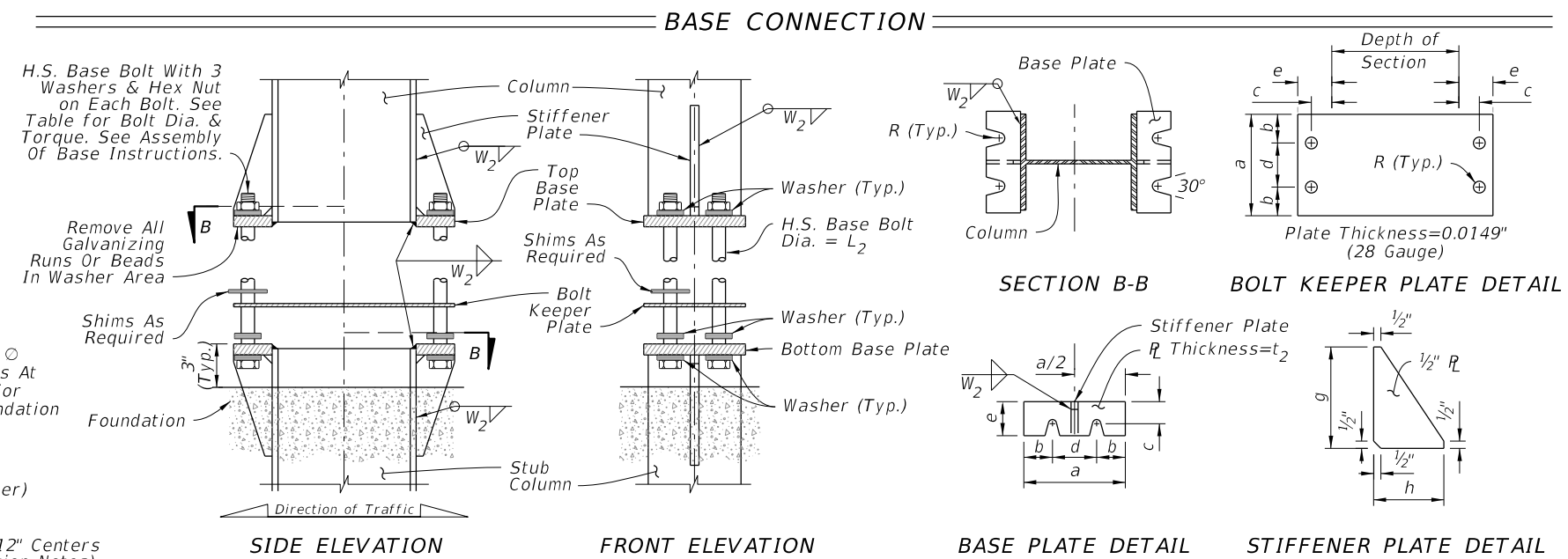

ALTERNATIVE BASE CONNECTION DATA												
Steel Section*	a	b	c	d	e	t ₂	L ₂	R	Torque (lbf*in)	g	h	W ₂
W 6x12	4-3/4"	1-1/8"	1-3/16"	2-1/2"	2"	1/2"	5/8"	3/8"	270 ± 45	5-1/8"	2"	1/4"
W 8x18	5-3/4"	1-1/2"	1-3/8"	2-3/4"	2-3/16"	5/8"	3/4"	7/16"	445 ± 75	6-1/4"	2-3/16"	1/4"
W 8x24	7"	1-3/4"	1-3/8"	3-1/2"	2-3/8"	3/4"	3/4"	7/16"	445 ± 75	8"	2-3/8"	5/16"
W 10x33	8"	2"	1-9/16"	4"	2-3/4"	3/4"	1"	9/16"	580 ± 90	8"	2-3/4"	5/16"
W 12x45	8"	2"	1-9/16"	4"	3"	3/4"	1"	9/16"	580 ± 90	8"	3"	5/16"

* Designations: (Nominal Depth in inches) x (weight in pounds per linear foot).

ALTERNATIVE BASE CONNECTION FOUNDATION AND BASE CONNECTION DETAILS

9/10/2024 2:43:31 PM

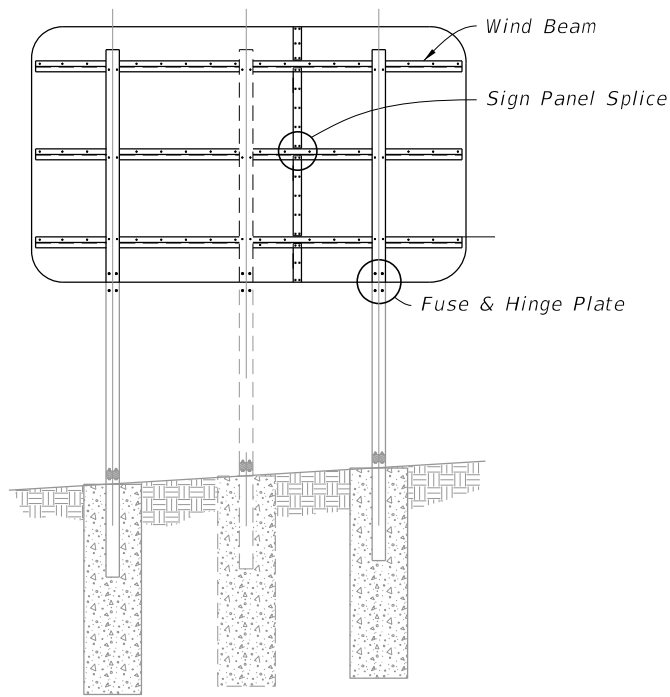

BACK ELEVATION

MULTI-COLUMN SIGN ASSEMBLY

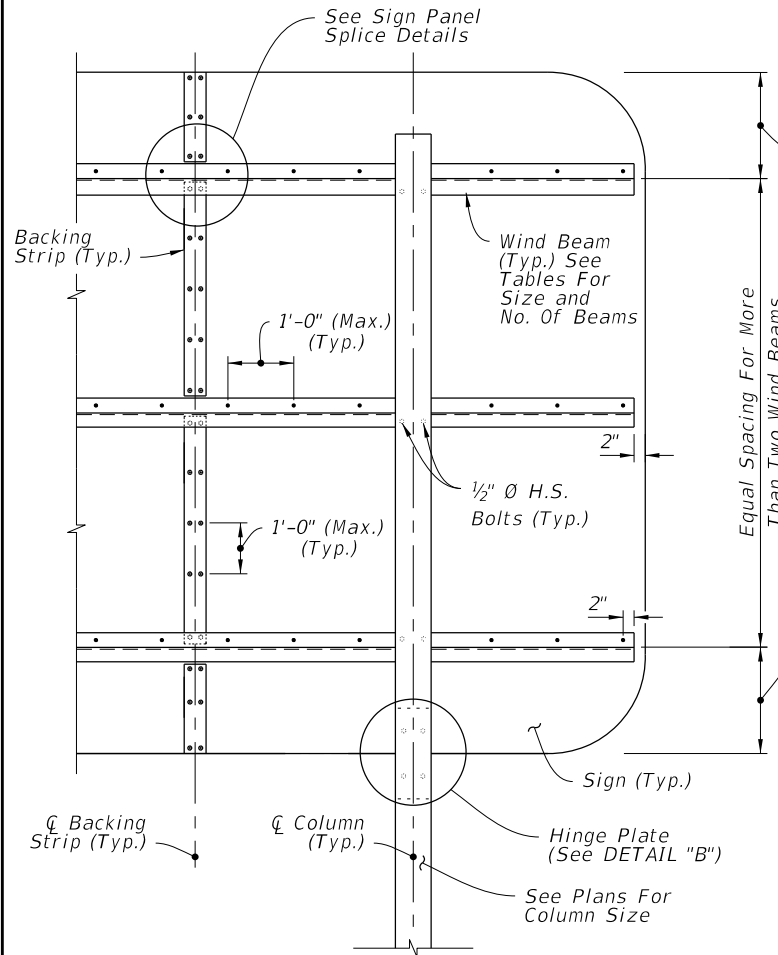

BACK ELEVATION

MULTI-COLUMN SIGN BACK PANEL

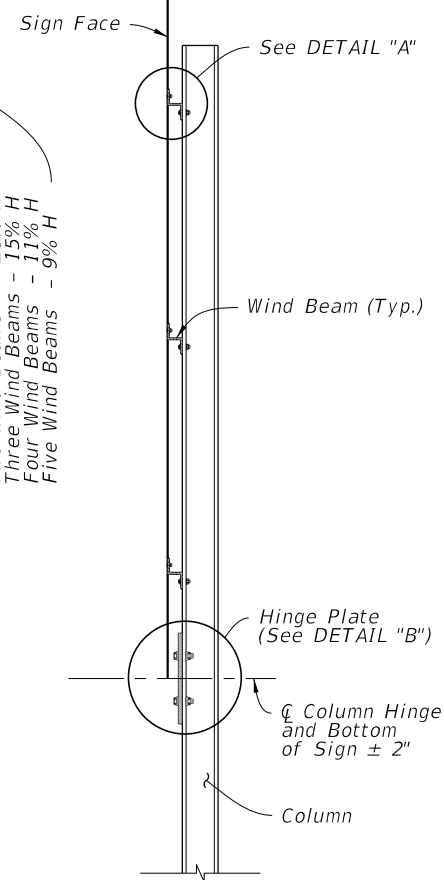

SIDE ELEVATION

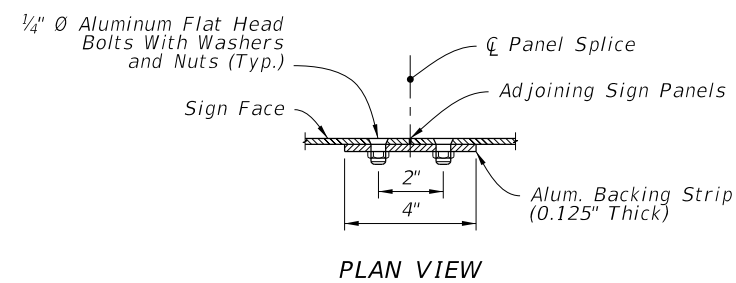

PLAN VIEW

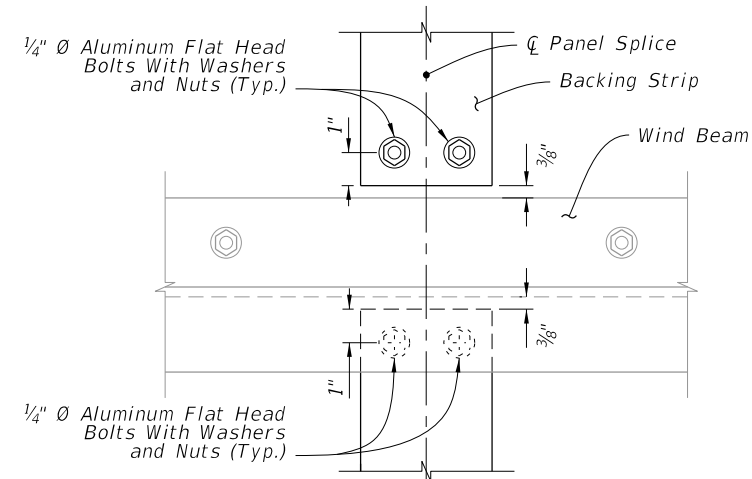

ELEVATION

SIGN PANEL SPLICE

NUMBER OF WIND BEAMS BASED ON SIGN HEIGHT (H)

2 Beams	3 Beams	4 Beams	5 Beams
$H \leq 8'$	$8' < H \leq 12'$	$12' < H \leq 16'$	$16' < H \leq 20'$

WIND BEAM SIZE BASED ON SIGN WIDTH (W)

2 Columns	3 Columns	Aluminum Beam Size **
$W \leq 12'$	$W \leq 18'$	Z 1-3/4 x 1-3/4 x 1.09
$12' < W \leq 20'$	$18' < W \leq 30'$	Z 3 x 2-1/16 x 2.33
$20' < W \leq 25'$	$30' < W \leq 39'$	Z 4-1/16 x 3-1/8 x 3.57

**Designation gives (Member Depth in inches) x (Flange Width in inches) x (lb/ft)

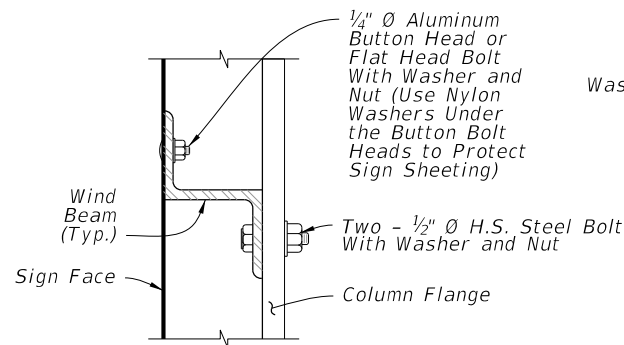

DETAIL "A"

FUSE (HINGE) PLATE DATA

Steel Section*	a	b	c	d	e	t ₂	D ₁	D ₂	L ₁
S 3x5.7	7-1/4"	2-3/8"	1-1/4"	1/2"	9/16"	3/8"	7/16"	9/16"	1/2"
W 6x12	7-1/4"	4"	1-1/4"	7/8"	15/16"	3/8"	13/16"	11/16"	5/8"
W 8x18	8-1/4"	5-1/4"	1-3/8"	1-1/8"	1-1/4"	3/8"	1"	13/16"	3/4"
W 8x24	8-1/4"	6-1/2"	1-3/8"	1-1/2"	1-1/2"	1/2"	1"	13/16"	3/4"
W 10x33	9-1/4"	8"	2"	1-3/4"	1-3/4"	5/8"	1-1/8"	1-1/16"	1"
W 12x45	11"	8"	2"	1-3/4"	1-3/4"	3/4"	1-5/16"	1-1/16"	1"

* Designations: (Nominal Depth in inches) x (Weight in Pounds Per Linear Foot)

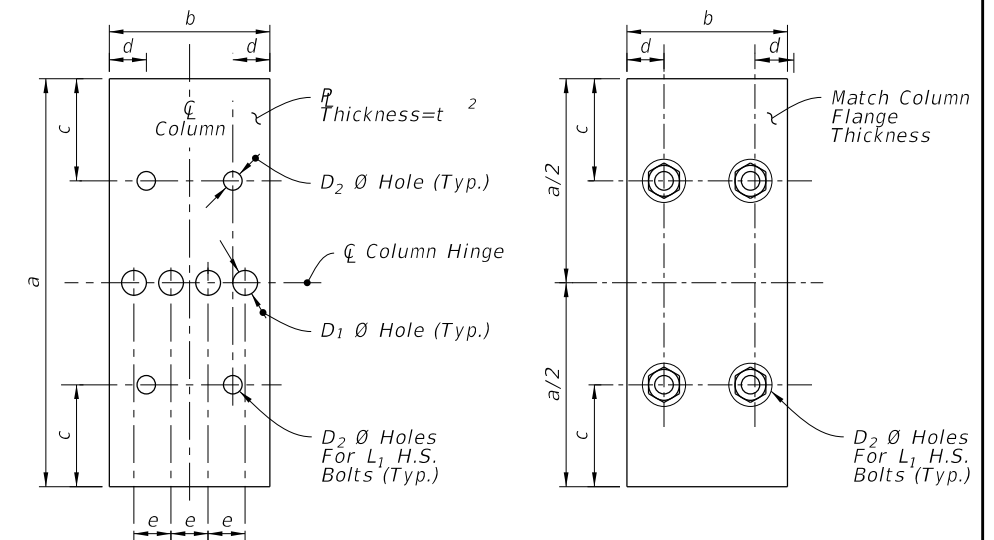

FUSE PLATE

HINGE PLATE

FUSE & HINGE PLATE

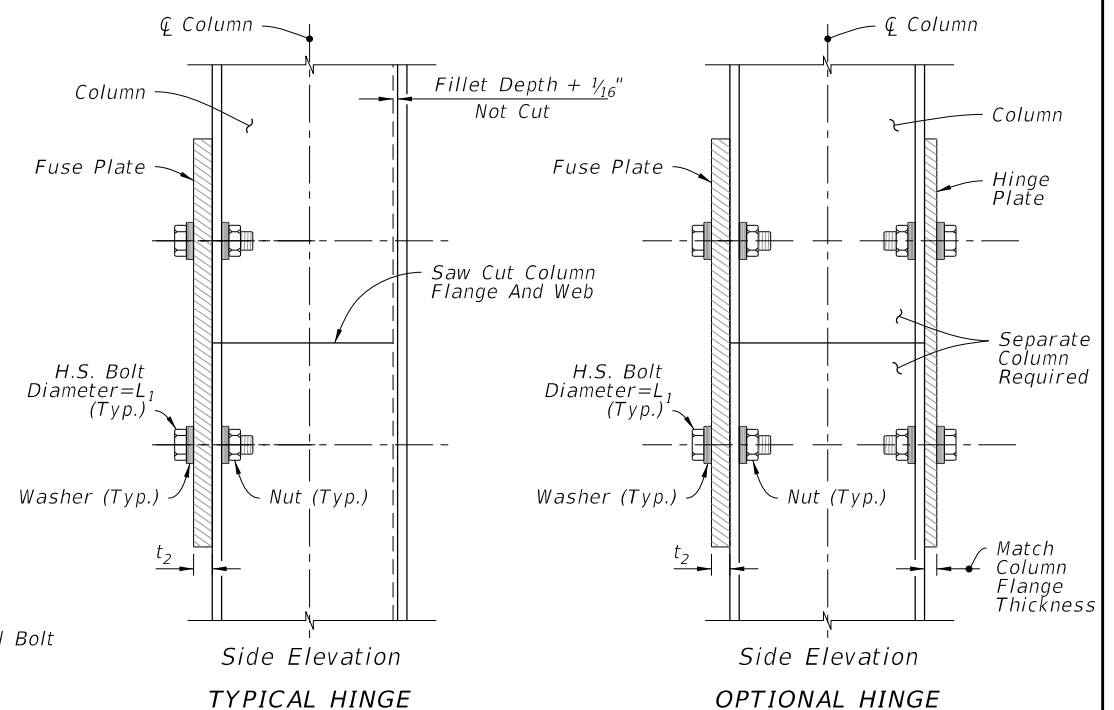

Side Elevation
TYPICAL HINGE

Side Elevation
OPTIONAL HINGE

DETAIL "B"

WIND BEAM, BACKING STRIP & FUSE/HINGE PLATE DETAILS

9/10/2024 2:43:36 PM

LAST REVISION	DESCRIPTION:
11/01/23	