

GENERAL NOTES:

1. Work with Index 700-010 for additional notes and the assembly of base connection.
2. Meet the requirements of Specification 700.
3. Place galvanized steel shims between the Sleeve and Post to obtain a tight fit between the Post and Sleeve.
4. Wind Beam and Vertical Brace: Aluminum Z 3 x 2¹¹/₁₆ x 3.38. Install Vertical Brace on 7'-0" to 8'-0" signs only.
5. Use Brass shims to plumb the post.
6. Use nylon washers under the button bolt heads to protect sign sheeting. Use aluminum washers under nut.
7. Aluminum Columns: ASTM B429 Alloy 6061-T6.

COLUMN SELECTION AND FOOTING SIZE TABLE							
Sign Size Width x Height	Column Size Diameter x Thickness	Sleeve Size Diameter x Thickness	U-bolt Diameter	Base Bolt Diameter x Length	Torque lbs./in	Base Plate Thickness	Footing Depth
5'-0" x 4'-0"	4 NPS Schedule 80 (4.5" x 0.337")	5 NPS Schedule 120 (5.563" x 0.5")	1/2"	5/8" x 3 1/2"	270 +/- 45	1"	6'-0"
6'-0" x 4'-0"	5 NPS Schedule 80 (5.563" x 0.375")	6 NPS Schedule 80 (6.625" x 0.432")	5/8"	3/4" x 4"	445 +/- 75	1 1/8"	6'-6"
7'-0" x 4'-0"							7'-0"

TYPICAL SECTION

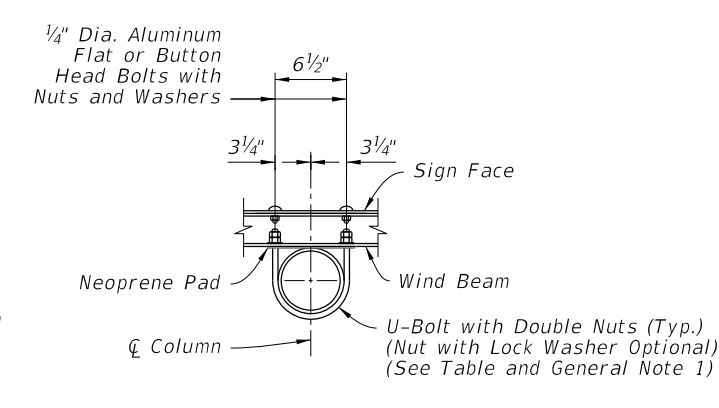
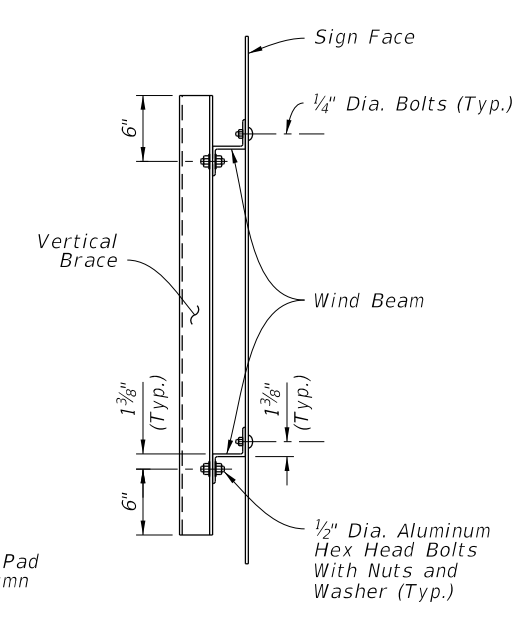
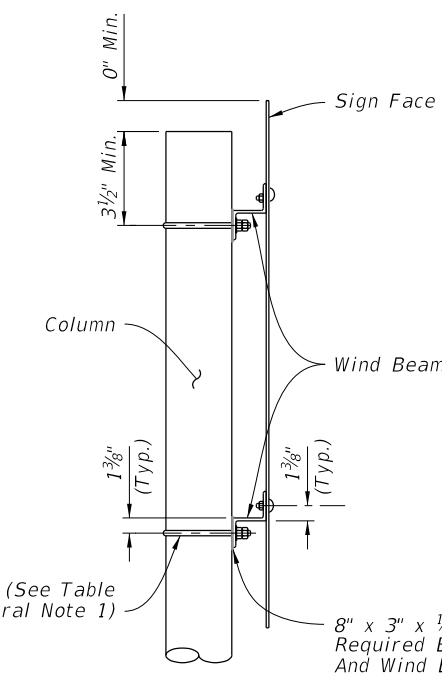
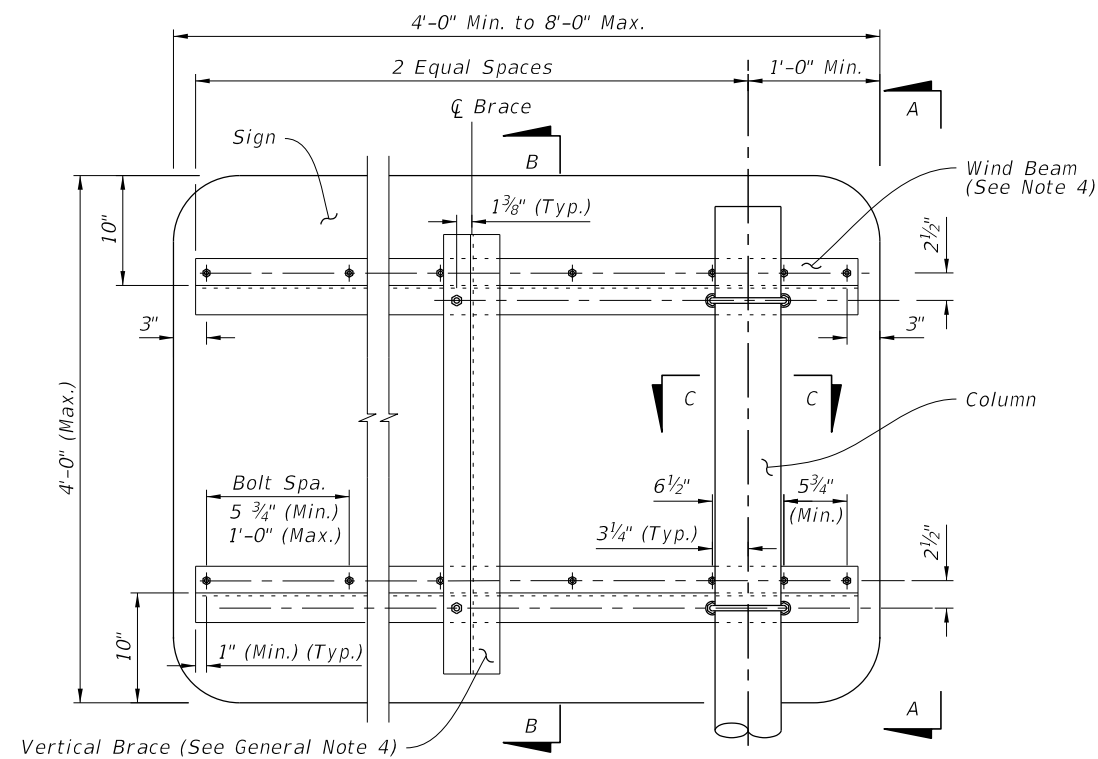

SIGN DETAIL

VIEW A-A

SECTION B-B

SECTION C-C

9/10/2024 2:40:31 PM

LAST REVISION 11/01/23	DESCRIPTION:		FY 2025-26 STANDARD PLANS	SINGLE COLUMN CANTILEVER GROUND MOUNTED SIGN	INDEX	SHEET
					700-011	1 of 2

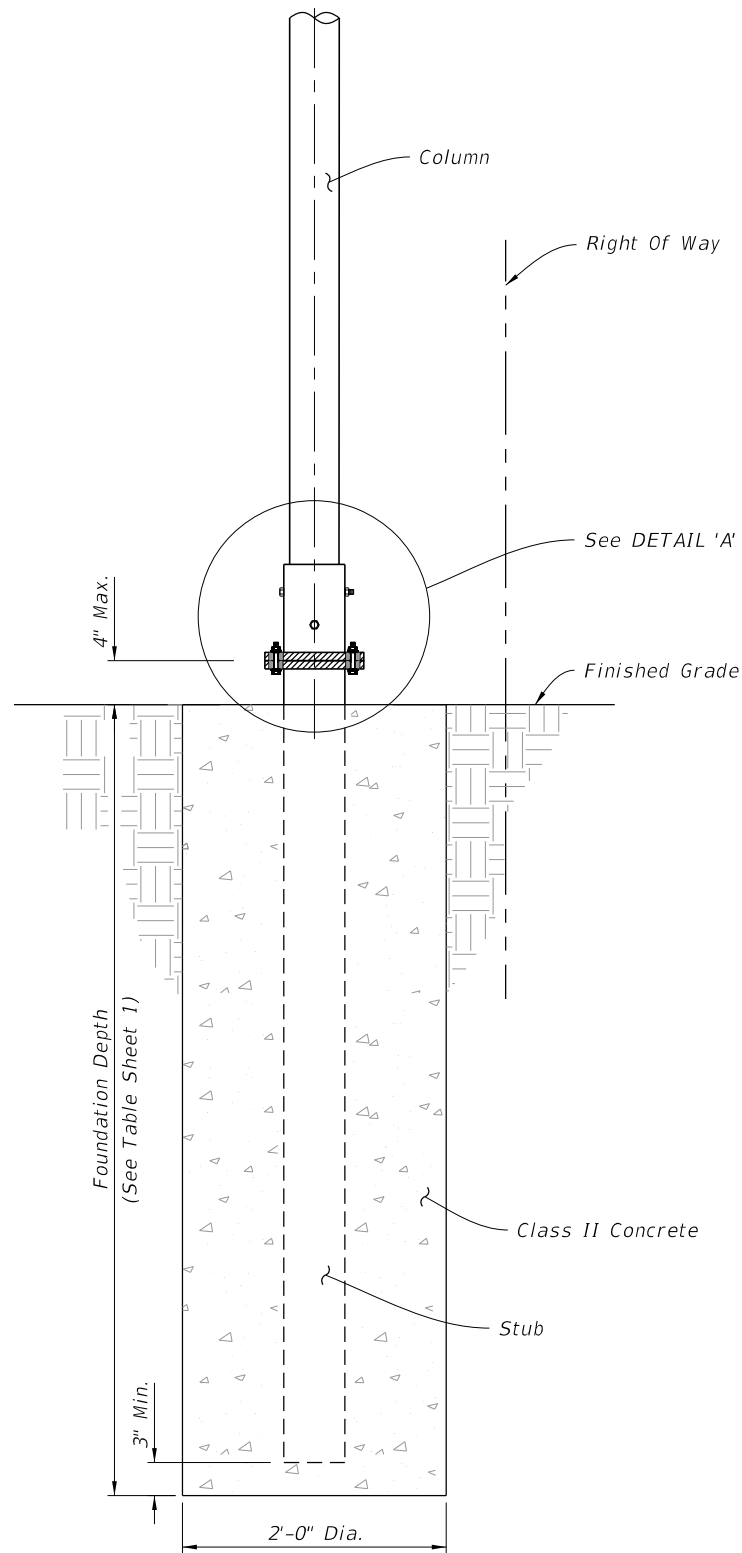

BASE AND FOUNDATION DETAIL

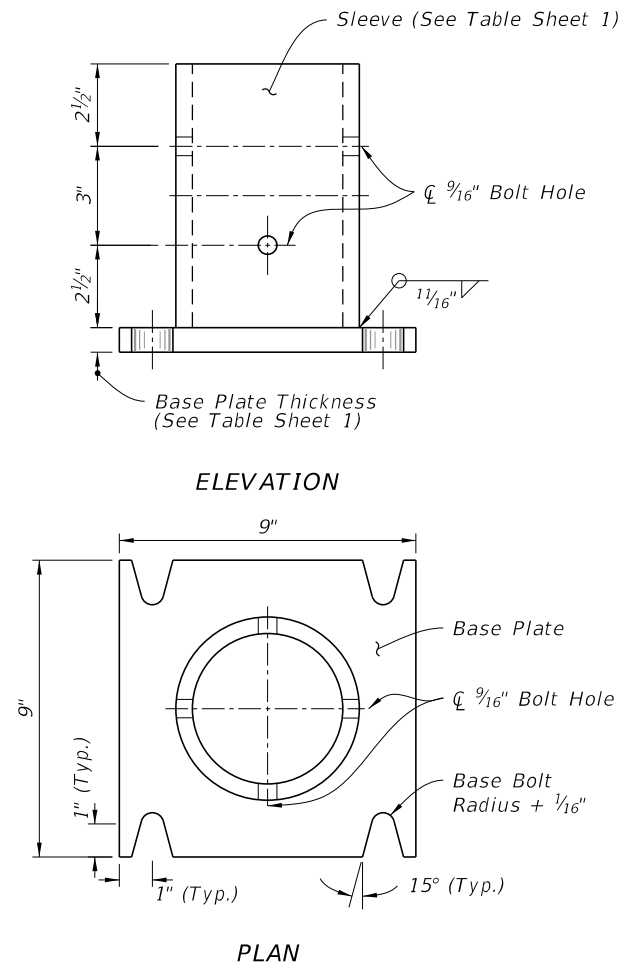

SLEEVE & BASE PLATE DETAILS

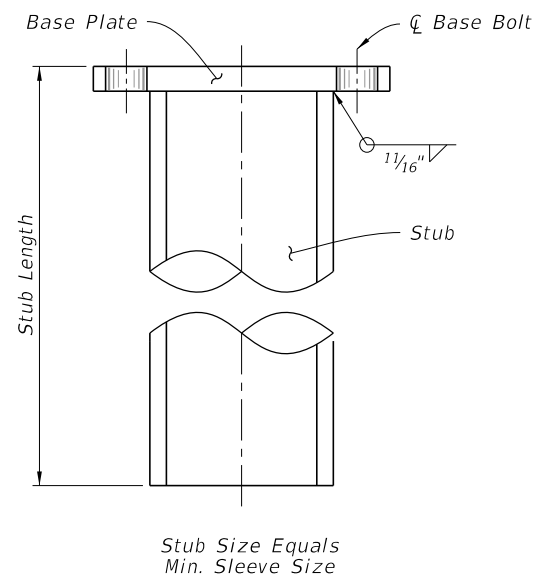

STUB DETAIL

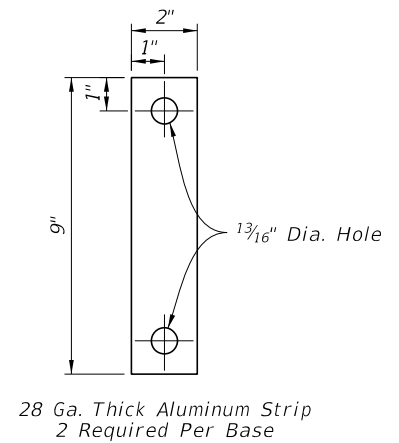

BOLT KEEPER PLATE DETAIL

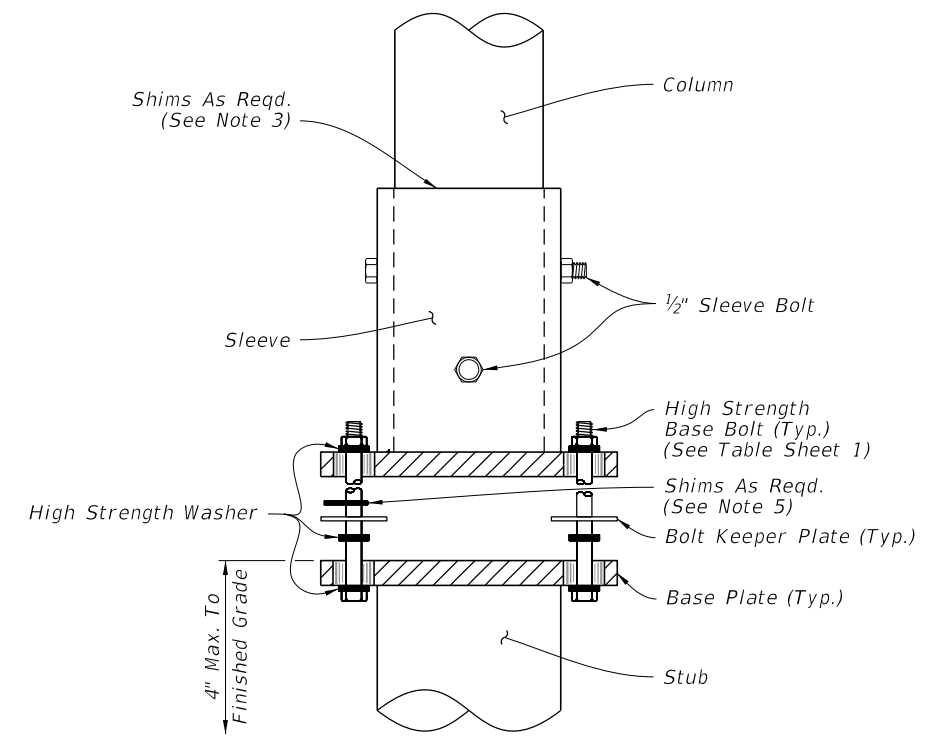

DETAIL 'A'

9/10/2024 2:40:38 PM

LAST REVISION 11/01/21	REVISION	DESCRIPTION:		FY 2025-26 STANDARD PLANS	SINGLE COLUMN CANTILEVER GROUND MOUNTED SIGN	INDEX 700-011	SHEET 2 of 2
---------------------------	----------	--------------	---	------------------------------	---	------------------	-----------------