

VAULT TOP

NOTES:

- GENERAL:** Construct the vault top and bottom with Class II or IV concrete. Use steel reinforcement bars where shown. Construct the concrete apron with Class NS concrete. Work with Index 425-001 for supplemental details, including corner connections, wall reinforcing splice details, and the manhole cover.
- MANHOLE COVER:** Use the 2'-11³/₄" cover per Index 425-001, except the cover must be a single piece with its material cast continuously across the joint shown in the 2-piece cover detail. As a result, only 4 pick-up holes around the outer edge will be included as shown herein. Also, change the lettering on top to "TPK FIBER OPTIC" by default, or use custom wording if defined in the Plans.
- CONDUITS:** Place conduits through the 5" x 20" blockouts where shown in the Plans or as required by the Engineer. Fill the blockouts with non-shrink grout around the conduits as shown.
- CABLE SUPPORT HOOKS & GROUND RODS:** Place hooks (approx. 7" length) with adjustable rack system located within the 1'-10" range shown herein. Position the hooks as shown in the Plans or as required by the Engineer. Provide shop drawings or manufacturer's specifications for all hooks, racks, anchors, fasteners, straps, and ground rod systems for the approval of the Engineer. The wound fiber optic cable and splice enclosures are generally supported by the hooks and placed above the elevations per Note 6.
- SPLICE ENCLOSURES:** Mount splice enclosures on the hooks where shown in the Plans or as required by the Engineer. Provide shop drawings or manufacturer's specification sheets for the approval of the Engineer.
- WATER INTRUSION:** For general conditions, place fiber optic splice vault tops at elevations above the seasonal high groundwater table (SHGWT) as shown. When splice vaults are placed within drainage, water treatment, or water conveyance areas, place the structure's top above the drainage feature elevation.

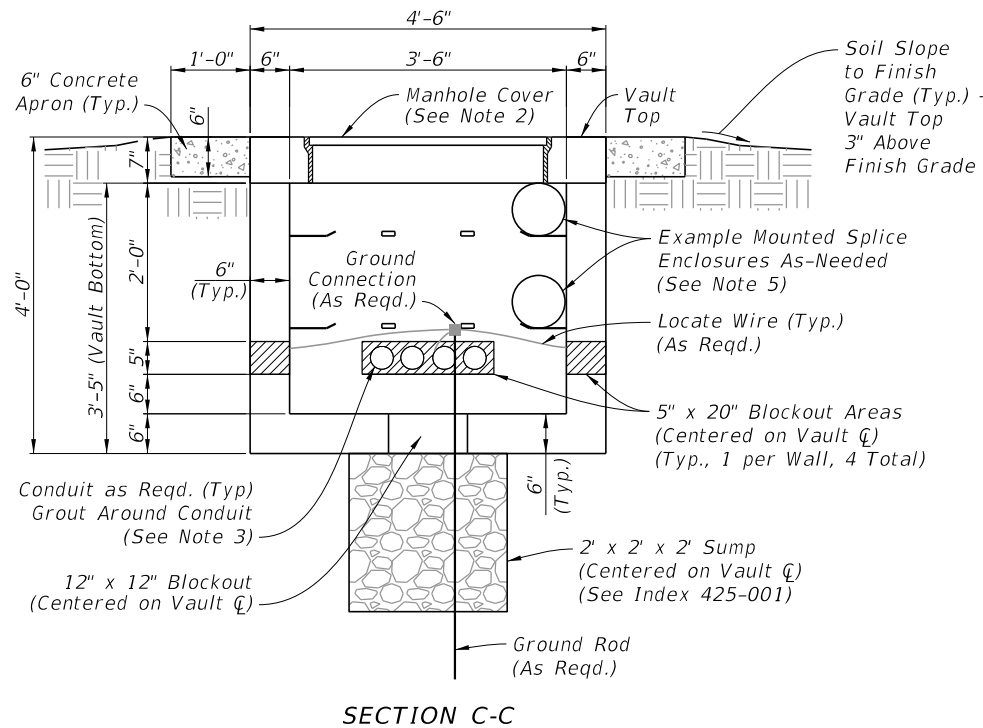
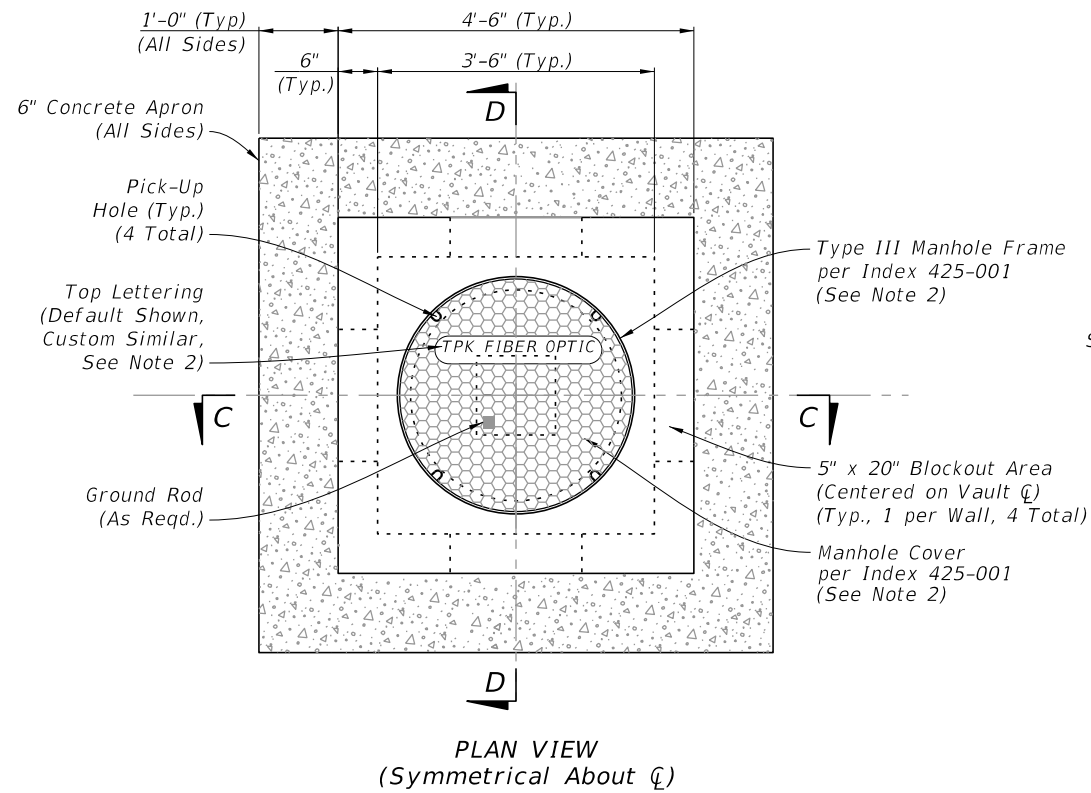

SECTION C-C

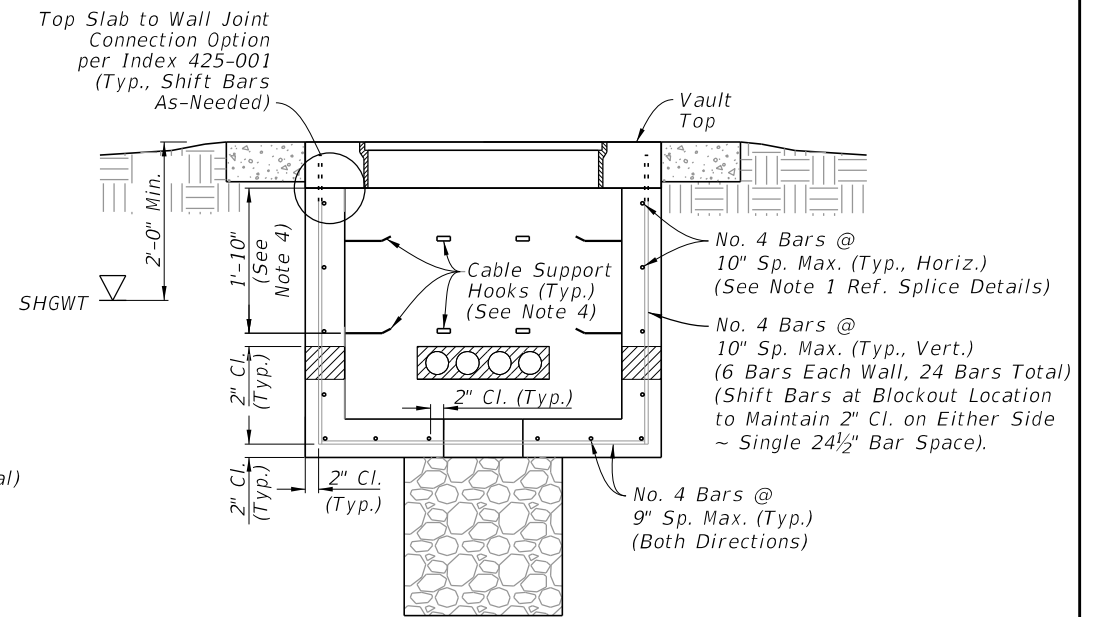

REINFORCING & MISCELLANEOUS DIMENSIONAL DETAILS
(Symmetrical About CL, All Walls Similar)
(Vault Top Reinforcing Not Shown)

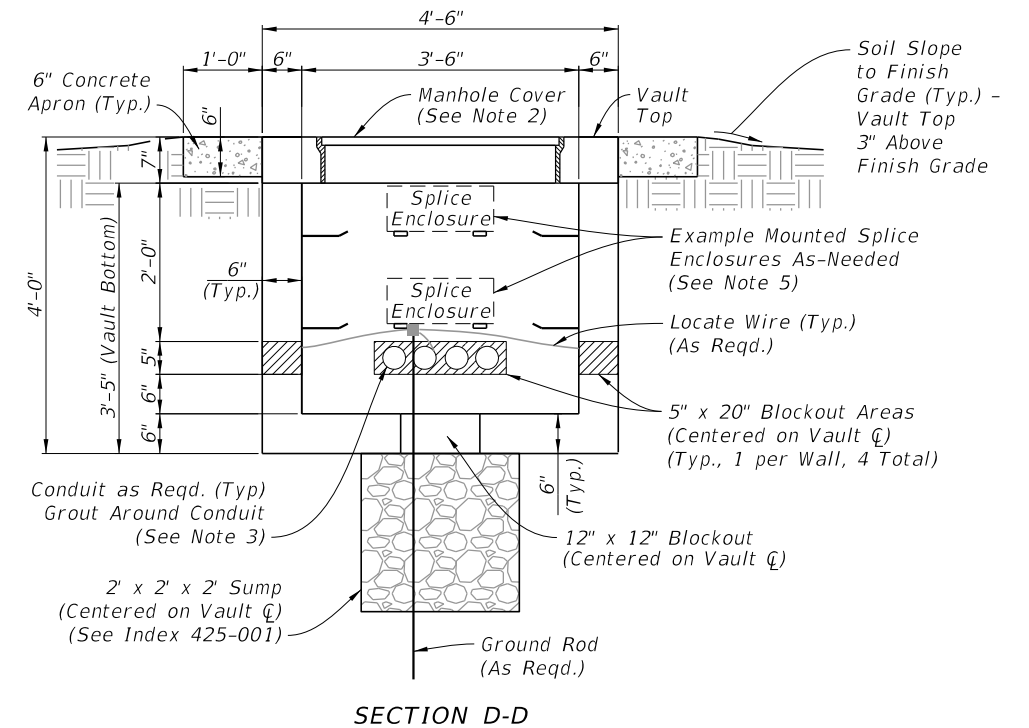

SECTION D-D

FIBER OPTIC SPLICE VAULT

9/10/2024 2:19:26 PM

LAST REVISION 11/01/24	DESCRIPTION:	 FY 2025-26 STANDARD PLANS	FIBER OPTIC SPLICE VAULT	INDEX 635-005	SHEET 1 of 1
---------------------------	--------------	--	---------------------------------	------------------	-----------------