

PICTORIAL

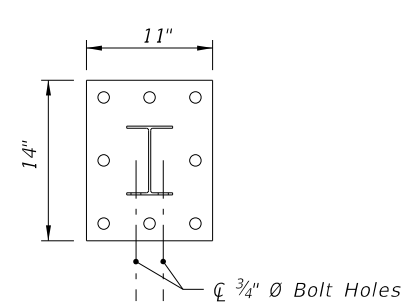

TOP VIEW

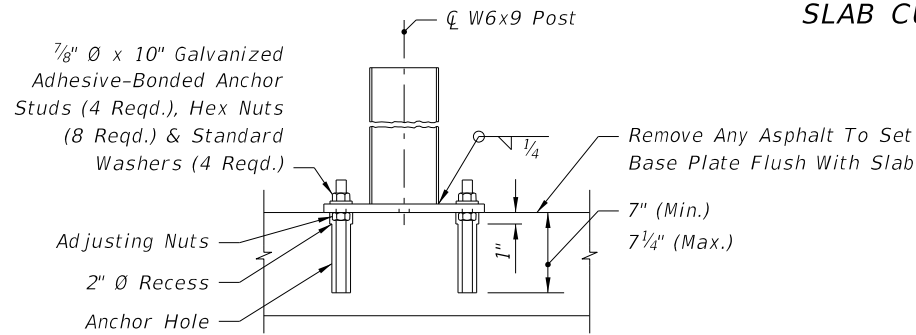

SIDE VIEW

SPECIAL STEEL POST FOR ROADWAY THRIE-BEAM TRANSITIONS TO BRIDGE TRAFFIC RAILING RETROFITS

CURB TYPE F FLARE WHEN END OF EXISTING APPROACH SLAB CURB EXPOSED

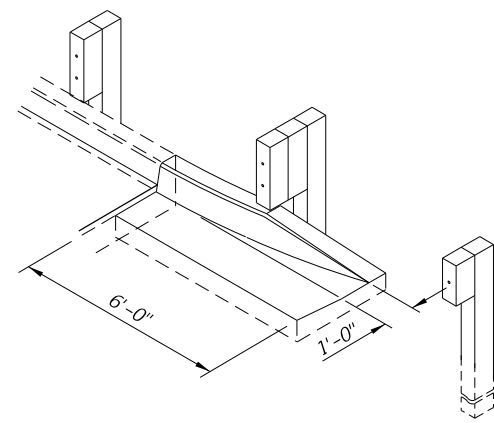

- GENERAL NOTES**
1. This index provides guardrail transition details for approach and trailing end guardrail connections to existing bridges, including details for connecting to traffic railing retrofits and safety shape barriers on existing bridges. Sheets 1 through 26 apply to bridges with retrofitted traffic railings (Sheet 26 shows the trailing end guardrail connections). Sheets 27 and 28 apply to bridges with safety shape traffic railing, and they provide approach and trailing end transition connection details for guardrail. Construct these guardrail transitions and connections where called for in the plans.
 2. For miscellaneous guardrail components and construction details that are not provided in this Index, refer to Index 536-001. Place Rectangular Washers over panel face at Thrie-Beam Terminal Connector splice bolts.

NOTES FOR GUARDRAIL TRANSITIONS CONNECTING TO TRAFFIC RAILING RETROFITS ON EXISTING BRIDGES

1. The transition detail shown on this sheet shows (a) the standard post spacings within the typical thrie-beam approach transitions connecting to existing bridges with retrofit traffic railings, and (b) depict the typical alignments of the approach transitions.
2. The curb and gutter flare shown on this sheet is typical of flares that are to be constructed when approach slab curbs extend to the beginning of the slab, and where other treatment to curb blunt ends are not in place.
3. The special steel post for roadway thrie-beam transitions detailed on this sheet is specific to all transition applications on this index that require one or more steel posts.

The special steel post and base plate assembly shall be fabricated in accordance with Specification 967.

Anchor studs shall be fully threaded rods in accordance with ASTM F1554 Grade 36 or ASTM A193 Grade B7. All nuts shall be heavy hex in accordance with ASTM A563 or ASTM A19

4. Anchor studs and nuts shall be hot-dip zinc coated in accordance with the Specifications. After the nuts have been snug tightened, the anchor stud threads shall be single punch distorted immediately above the top nuts to prevent loosening of the nuts. Distorted threads shall be coated with a galvanizing compound in accordance with the Specifications.

Adhesive bonding material systems for anchors shall comply with Specification 937 and be installed in accordance with Specification 416.4. Nested beam extensions and points for terminal connector attachments will vary for traffic railing barrier vertical face retrofits. The plan views for the vertical face retrofit barriers show the primary configurations for each particular scheme. The associated pictorial views show the variations.

5. For installing thrie-beam terminal connector to traffic railing vertical face retrofits, see notations on Sheets 15 through 18 and the flag notation on Sheet 26.

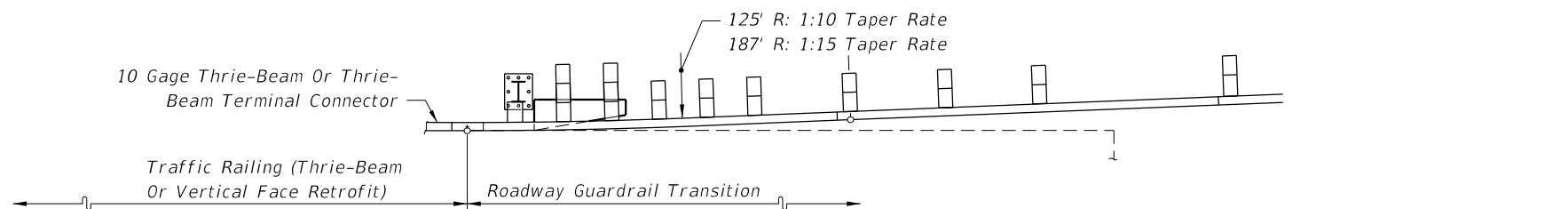

APPROACH SLAB WITHOUT CURB

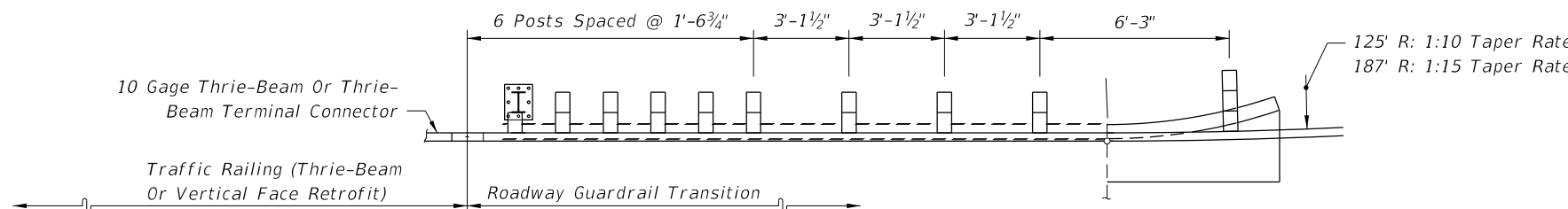

APPROACH SLAB WITH CURB

Longitudinal Location Of Transition Blocks And Curb End Flares Will Vary With Scheme Type

PARTIAL PLAN VIEWS

GUARDRAIL TRANSITION ALIGNMENTS FOR BRIDGE THRIE-BEAM AND VERTICAL FACE TRAFFIC RAILING RETROFIT

9/10/2024 1:53:17 PM

LAST REVISION 11/01/24	REVISION	DESCRIPTION:		FY 2025-26 STANDARD PLANS	GUARDRAIL TRANSITIONS AND CONNECTIONS FOR EXISTING BRIDGES	INDEX 536-002	SHEET 1 of 28
---------------------------	----------	--------------	--	------------------------------	---	------------------	------------------

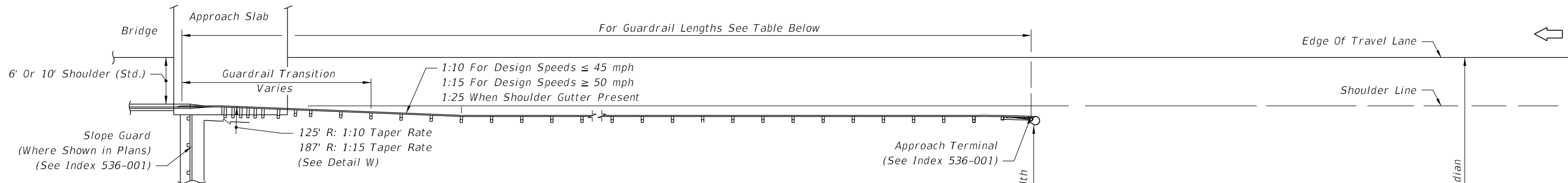

GUARDRAIL LENGTH (Ft.)							Notes: Lengths shown in the tables are based on Length of Advancement design and consider minimum median widths and clear zone widths for opposing travel lanes. Length of Advancement values are intended to better match existing conditions and layouts. Where a designer chooses to use the newer Length of Need process, the lengths shown in the tables may be superseded as detailed in the Plans. Lengths may also require adjustment for connection location on wing post or bridge traffic railing barrier, auxiliary lanes, skewed crossings, and other hazards if present.
Design Speed (mph)	Projected ADT	CZ (Ft.)	6' & 8' Rdwy. Shldr.		10' & 12' Rdwy. Shldr.		
			Min. Median Width	Guardrail Length	Min. Median Width	Guardrail Length	
60-70	≥ 1500	36	50	362.5	54	312.5	
60-70	< 1500	30	44	287.5	48	237.5	
55	≥ 1500	30	44	287.5	48	237.5	
55	< 1500	24	38	212.5	42	162.5	
45-50	≥ 1500	24	38	212.5	42	162.5	
45-50	< 1500	20	34	162.5	38	112.5	
45-50	Urban w/o Curb	24	38	212.5	42	162.5	
35-40	Urban w/o Curb	18	32	162.5	36	100.0	

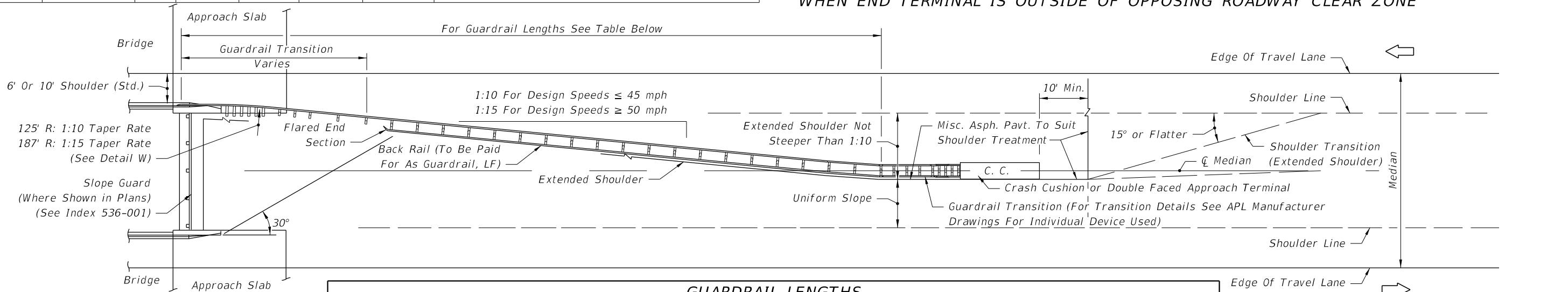

GUARDRAIL LENGTHS																
Median Width (ft.)	1:10 TAPER RATE								1:15 TAPER RATE							
	6' Bridge Shoulder				10' Bridge Shoulder				6' Bridge Shoulder				10' Bridge Shoulder			
	Panels (No.)		Length (Ft.)		Panels (No.)		Length (Ft.)		Panels (No.)		Length (Ft.)		Panels (No.)		Length (Ft.)	
	Front	Back	Total	Total	Front	Back	Total	Total	Front	Back	Total	Total	Front	Back	Total	Total
32	7.5	6	13.5	168.75	4.5	3	7.5	93.75	11.5	9	20.5	256.25	7.5	6	13.5	168.75
34	8.5	6	14.5	181.25	5.5	4	9.5	118.75	12.5	10	22.5	281.25	7.5	6	13.5	168.75
36	9.5	7	16.5	206.25	6.5	5	11.5	143.75	13.5	11	24.5	306.25	8.5	7	15.5	193.75
38	10.5	8	18.5	231.25	7.5	6	13.5	168.75	14.5	12	26.5	331.25	10.5	9	19.5	243.75
40	10.5	8	18.5	231.25	7.5	6	13.5	168.75	16.5	13	29.5	368.75	11.5	9	20.5	256.25
42	11.5	8	19.5	243.75	8.5	6	14.5	181.25	17.5	14	31.5	393.75	12.5	10	22.5	281.25
44	12.5	9	21.5	268.75	9.5	7	16.5	206.25	18.5	15	33.5	418.75	13.5	11	24.5	306.25
46	12.5	9	21.5	268.75	10.5	8	18.5	231.25	19.5	16	35.5	443.75	14.5	12	26.5	331.25
48	14.5	11	25.5	318.75	11.5	9	20.5	256.25	20.5	16	36.5	456.25	16.5	13	29.5	368.75

The lengths shown on this table are typical for roadways with standard width shoulders and a relocated connection to the existing wing post. Length requirements shall be determined on a site specific basis for both standard width and narrow bridge shoulders and for end anchorage or end shielding use. See design notes in above table.

WHEN END TERMINAL CANNOT BE LOCATED OUTSIDE OF OPPOSING ROADWAY CLEAR ZONE
APPROACH GUARDRAIL TREATMENTS FOR BRIDGES WITH CONCRETE TRAFFIC RAILING
EXTENDING LESS THAN FULL APPROACH SLAB LENGTH IN WIDE MEDIANS WITH FLUSH SHOULDERS

9/10/2024 1:53:32 PM

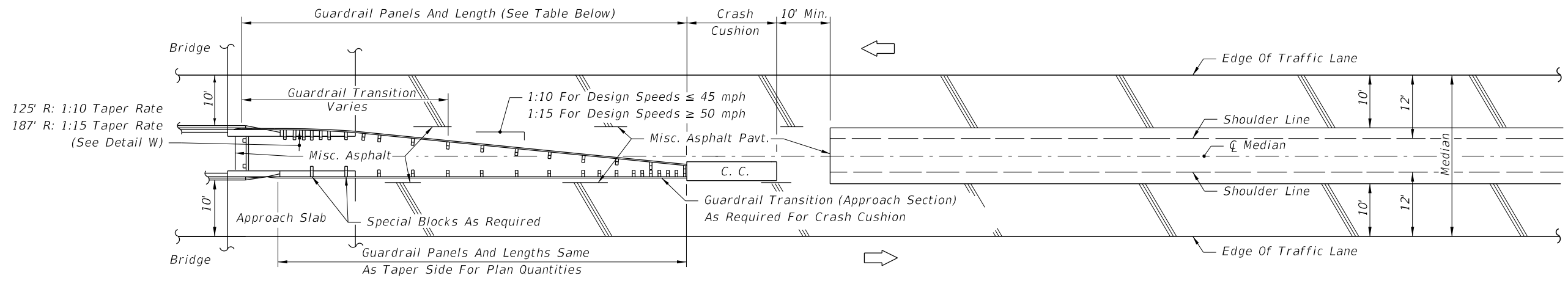

MEDIANS WITH 10' BRIDGE SHOULDERS

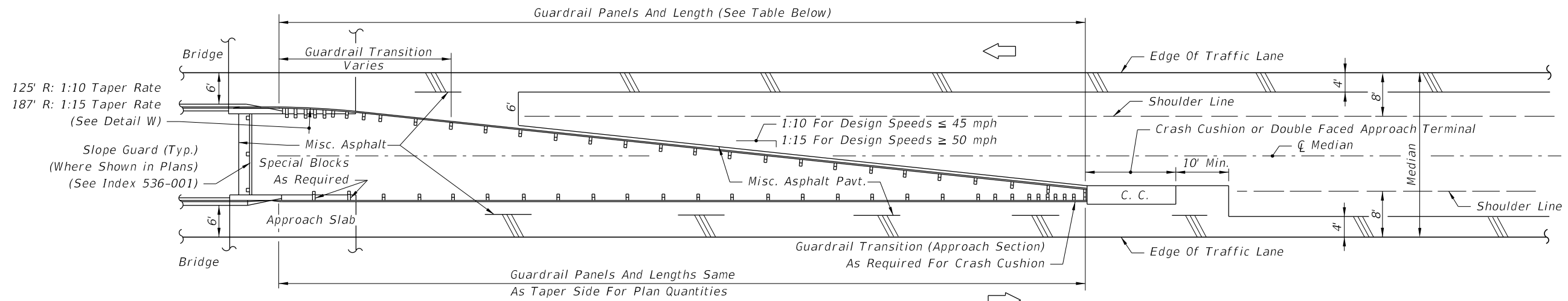

MEDIANS WITH 6' BRIDGE SHOULDERS

Note: The guardrail configurations shown apply only to parallel or near parallel bridges with open medians.

GUARDRAIL LENGTHS								
MEDIAN WIDTH (Ft.)	6' BRIDGE SHOULDERS				10' BRIDGE SHOULDERS			
	1:10 TAPER RATE		1:15 TAPER RATE		1:10 TAPER RATE		1:15 TAPER RATE	
	PANELS (No.)	LENGTH (Ft.)	PANELS (No.)	LENGTH (Ft.)	PANELS (No.)	LENGTH (Ft.)	PANELS (No.)	LENGTH (Ft.)
30	12.5	156.25	18.5	231.25	6.5	81.25	9.5	118.75
28	11.5	143.75	16.5	206.25	5.5	68.75	7.5	93.75
26	9.5	118.75	14.5	181.25	5.5*	68.75	5.5*	68.75
24	8.5	106.25	11.5	143.75	5.5*	68.75	5.5*	68.75

The lengths shown in this table are based on standard widths for roadway and bridge median shoulders. Length requirements for both standard width and narrow bridge shoulders and end anchorage or end shielding requirements shall be determined on a site specific basis. The number of panels may be reduced when installing a crash cushion more than 2.5' in width; see * below.

*Number shown is the minimum number of panels plus a W-Three beam transition panel; single faced guardrail must have a length of five (5) or more panels.

**APPROACH GUARDRAIL TREATMENTS FOR BRIDGES WITH CONCRETE TRAFFIC RAILING
EXTENDING LESS THAN FULL APPROACH SLAB LENGTH IN NARROW MEDIANS WITH FLUSH SHOULDERS**

9/10/2024 1:53:39 PM

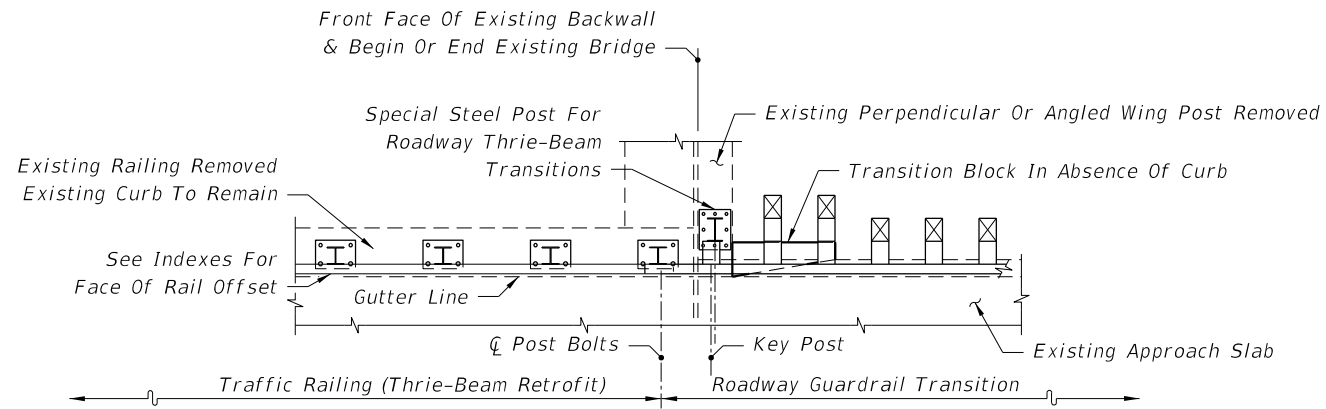

SEE INDEX 460-471 - SCHEME 1

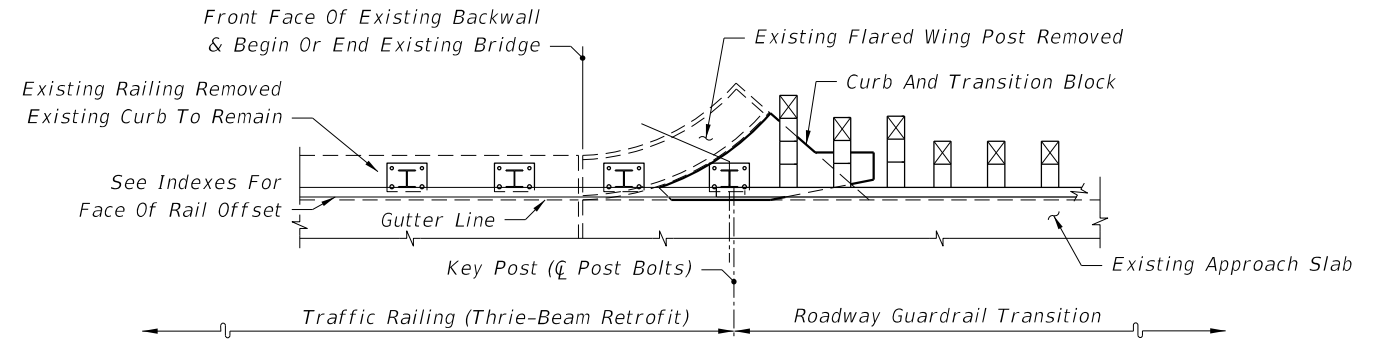

SEE INDEX 460-471 - SCHEME 3

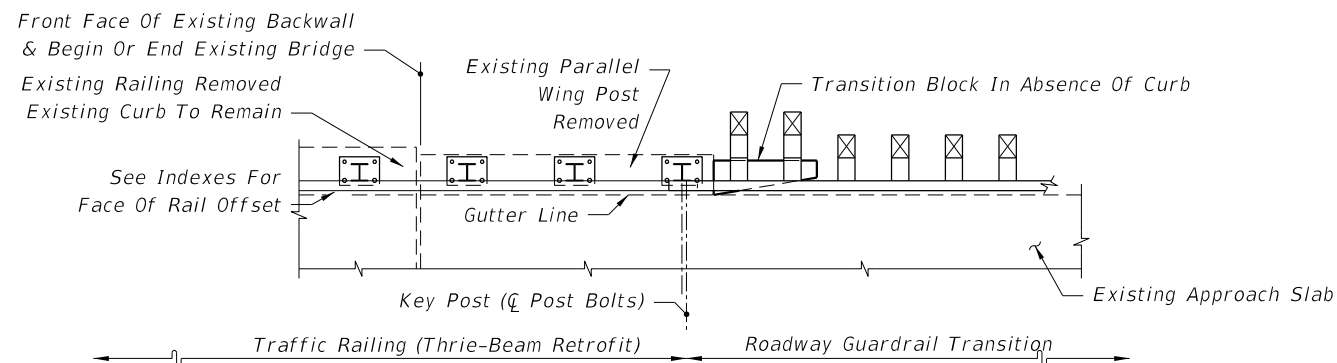

SEE INDEX 460-471 - SCHEME 2

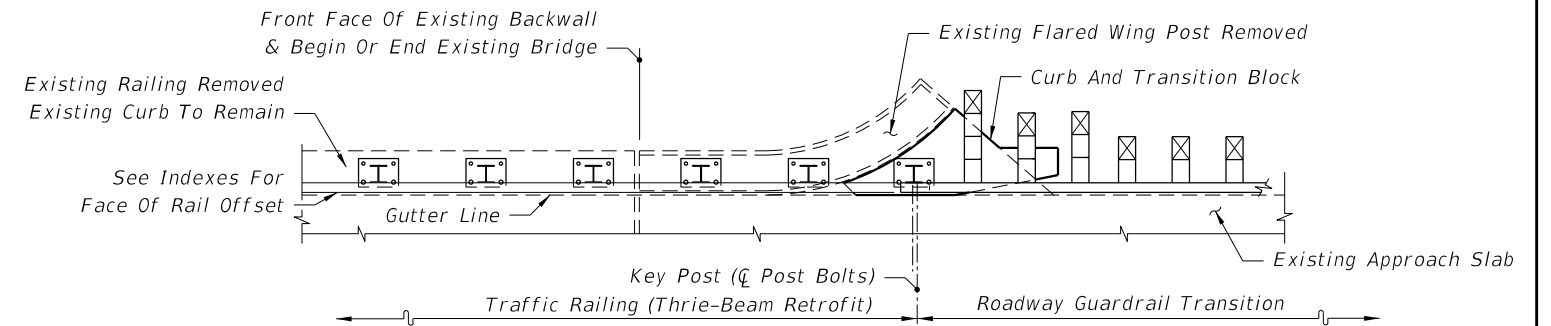

SEE INDEX 460-471 - SCHEME 3

PARTIAL PLAN VIEWS OF GUARDRAIL APPROACH TRANSITIONS AND CONNECTIONS
FOR BRIDGE TRAFFIC RAILING (THRIE-BEAM RETROFIT)

9/10/2024 1:53:46 PM

LAST REVISION 11/01/19	REVISION	DESCRIPTION:		FY 2025-26 STANDARD PLANS	GUARDRAIL TRANSITIONS AND CONNECTIONS FOR EXISTING BRIDGES	INDEX 536-002	SHEET 5 of 28
---------------------------	----------	--------------	---	------------------------------	---	------------------	------------------

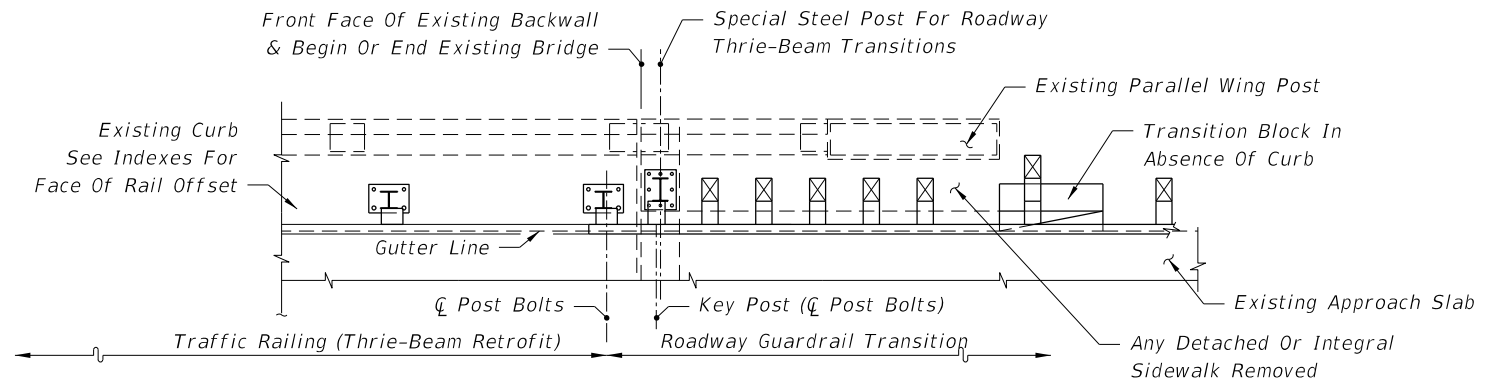

SEE INDEXES 460-472 & 460-475 - SCHEME 2

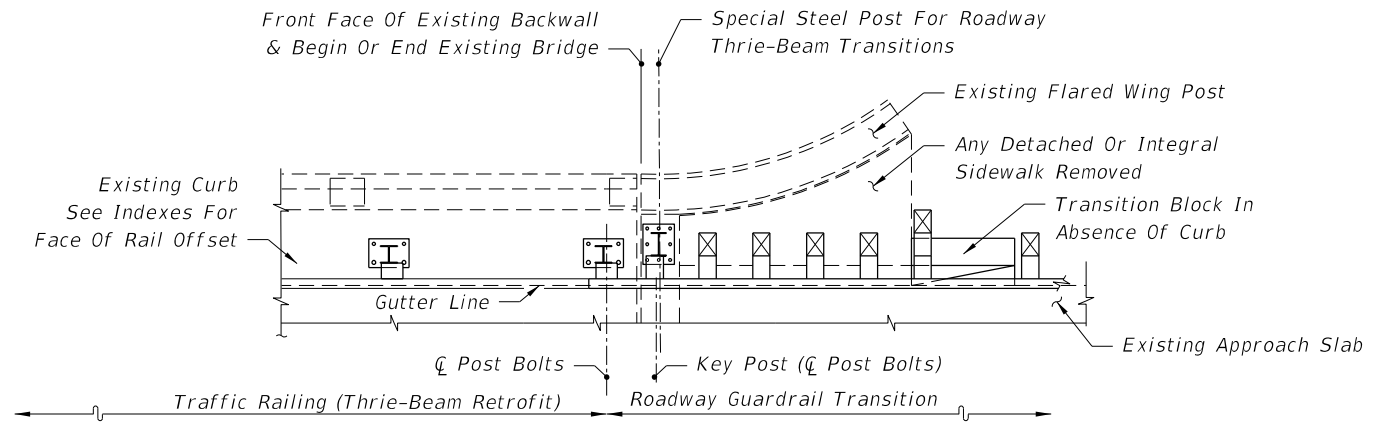

SEE INDEXES 460-472 & 460-475 - SCHEME 2

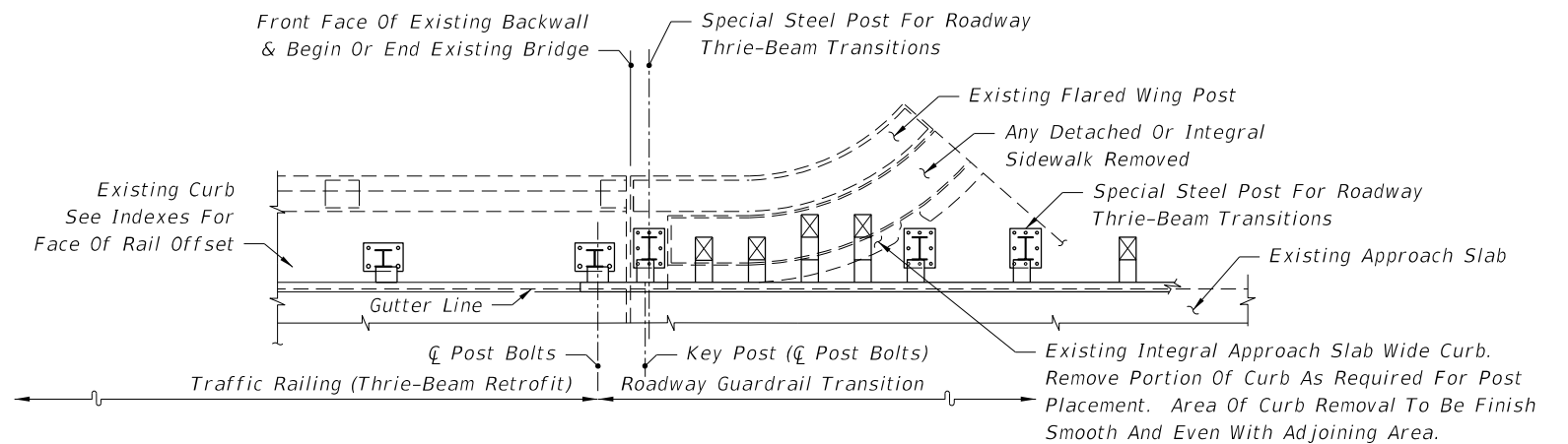

SEE INDEXES 460-472 & 460-475 - SCHEME 2

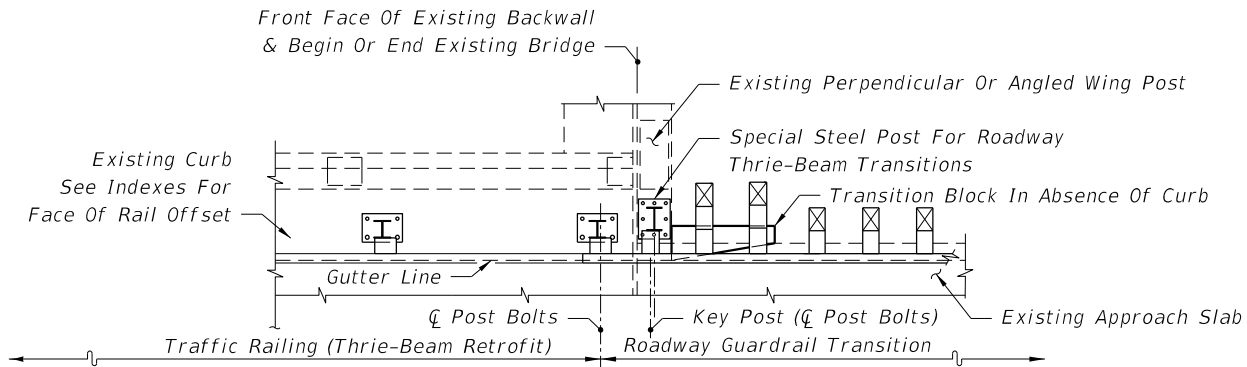

SEE INDEXES 460-472 & 460-475 - SCHEME 1

PARTIAL PLAN VIEWS OF GUARDRAIL APPROACH TRANSITIONS AND CONNECTIONS FOR BRIDGE TRAFFIC RAILING (THRIE-BEAM RETROFIT)

9/10/2024 1:53:53 PM

LAST REVISION 11/01/19	REVISION	DESCRIPTION:	 FY 2025-26 STANDARD PLANS	GUARDRAIL TRANSITIONS AND CONNECTIONS FOR EXISTING BRIDGES	INDEX 536-002	SHEET 6 of 28
---------------------------	----------	--------------	---	---	------------------	------------------

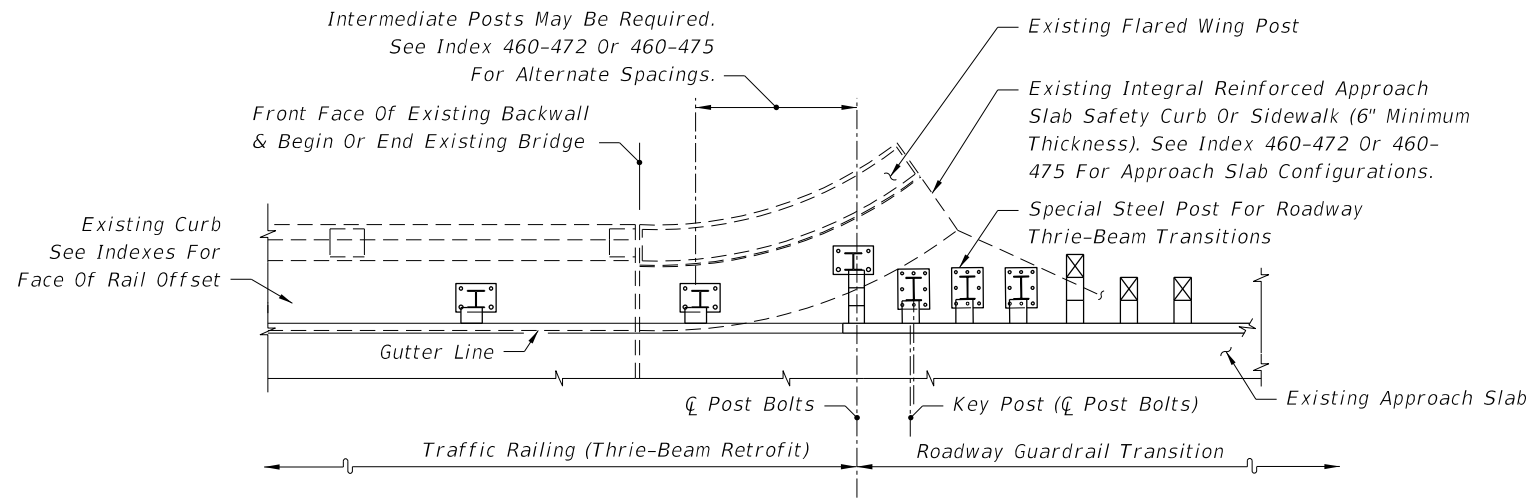

SEE INDEXES 460-472 & 460-475 - SCHEMES 3 & 4

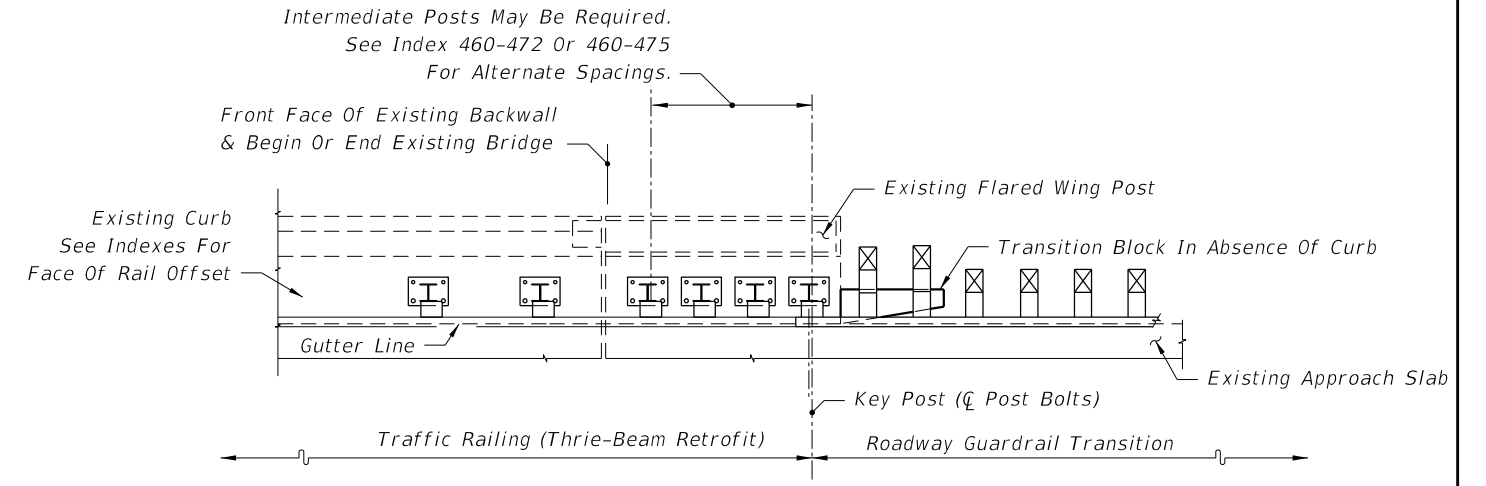

SEE INDEXES 460-472 & 460-475 - SCHEMES 5 & 6

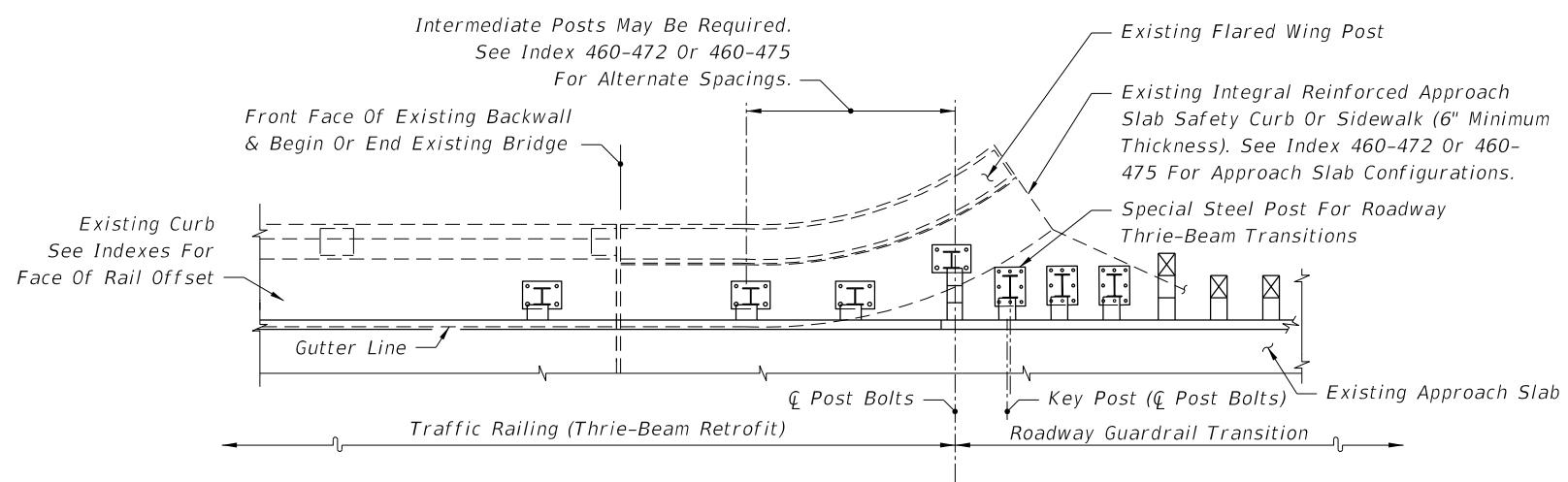

SEE INDEXES 460-472 & 460-475 - SCHEMES 3 & 4

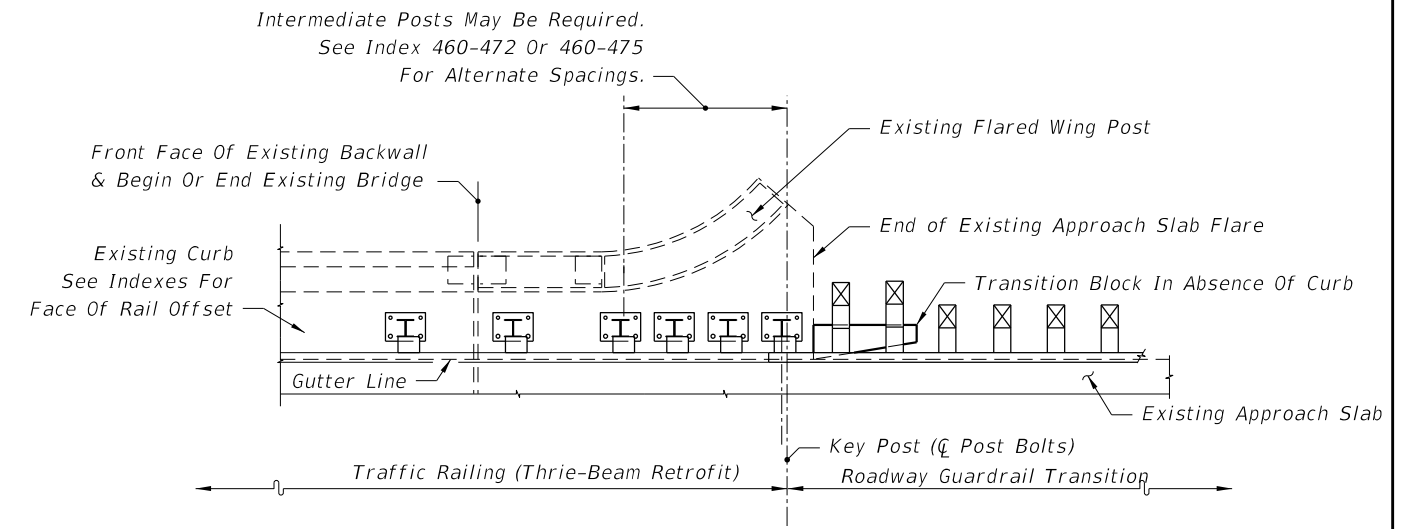

SEE INDEXES 460-472 & 460-475 - SCHEMES 5 & 6

PARTIAL PLAN VIEWS OF GUARDRAIL APPROACH TRANSITIONS AND CONNECTIONS FOR BRIDGE TRAFFIC RAILING (THRIE-BEAM RETROFIT)

9/10/2024 1:54:00 PM

LAST REVISION 11/01/19	REVISION	DESCRIPTION:		FY 2025-26 STANDARD PLANS	GUARDRAIL TRANSITIONS AND CONNECTIONS FOR EXISTING BRIDGES	INDEX 536-002	SHEET 7 of 28
---------------------------	----------	--------------	--	------------------------------	---	------------------	------------------

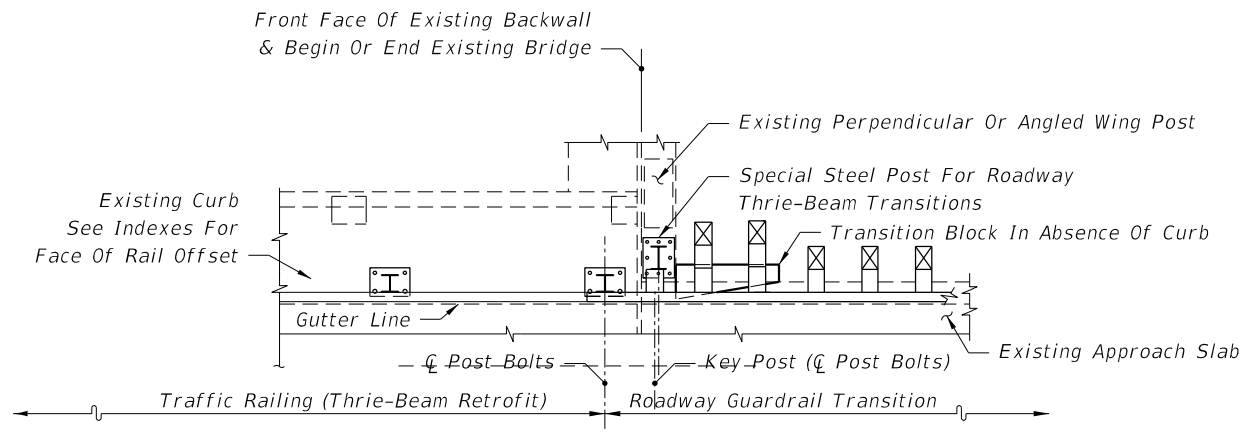

SEE INDEXES 460-473 & 460-476 - SCHEME 1

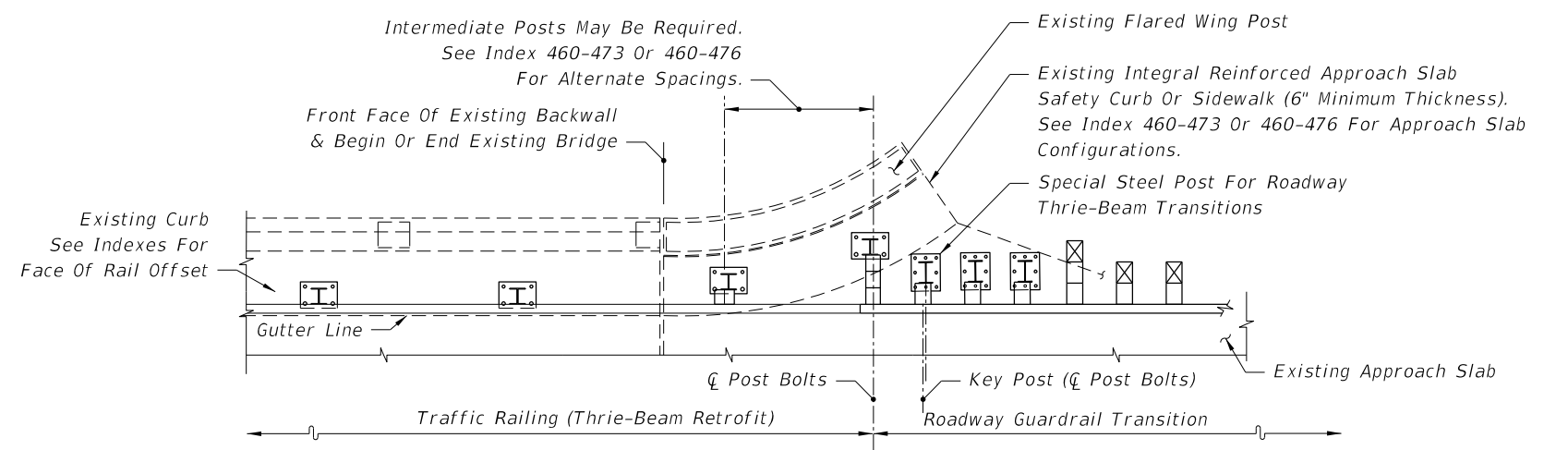

SEE INDEXES 460-473 & 460-476 - SCHEMES 3 & 4

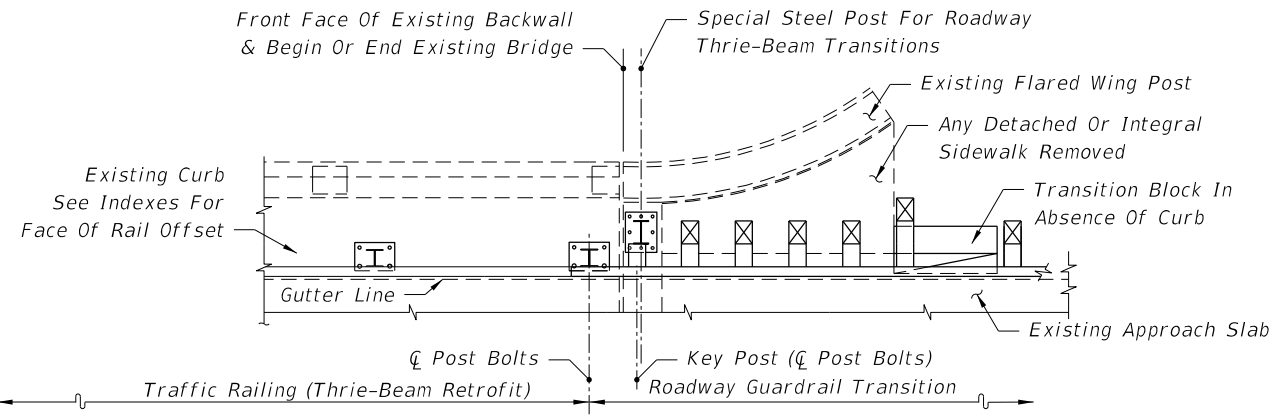

SEE INDEXES 460-473 & 460-476 - SCHEME 2

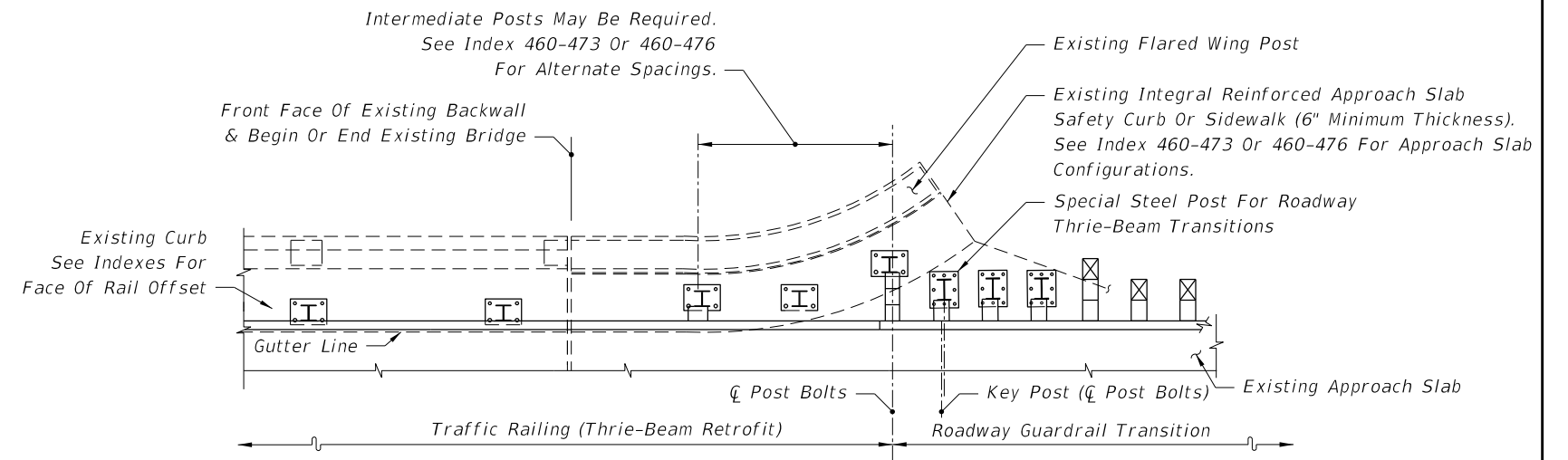

SEE INDEXES 460-473 & 460-476 - SCHEMES 3 & 4

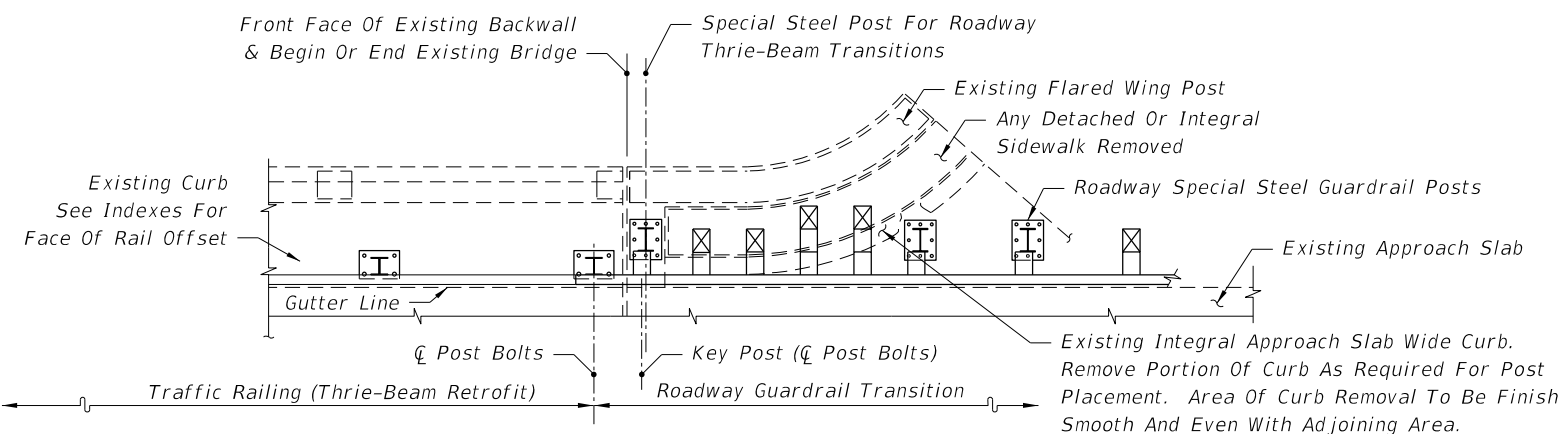

SEE INDEXES 460-473 & 460-476 - SCHEME 2

PARTIAL PLAN VIEWS OF GUARDRAIL APPROACH TRANSITIONS AND CONNECTIONS FOR BRIDGE TRAFFIC RAILING (THRIE-BEAM RETROFIT)

9/10/2024 1:54:06 PM

LAST REVISION 11/01/19	REVISION	DESCRIPTION:		FY 2025-26 STANDARD PLANS	GUARDRAIL TRANSITIONS AND CONNECTIONS FOR EXISTING BRIDGES	INDEX 536-002	SHEET 8 of 28
---------------------------	----------	--------------	--	------------------------------	---	------------------	------------------

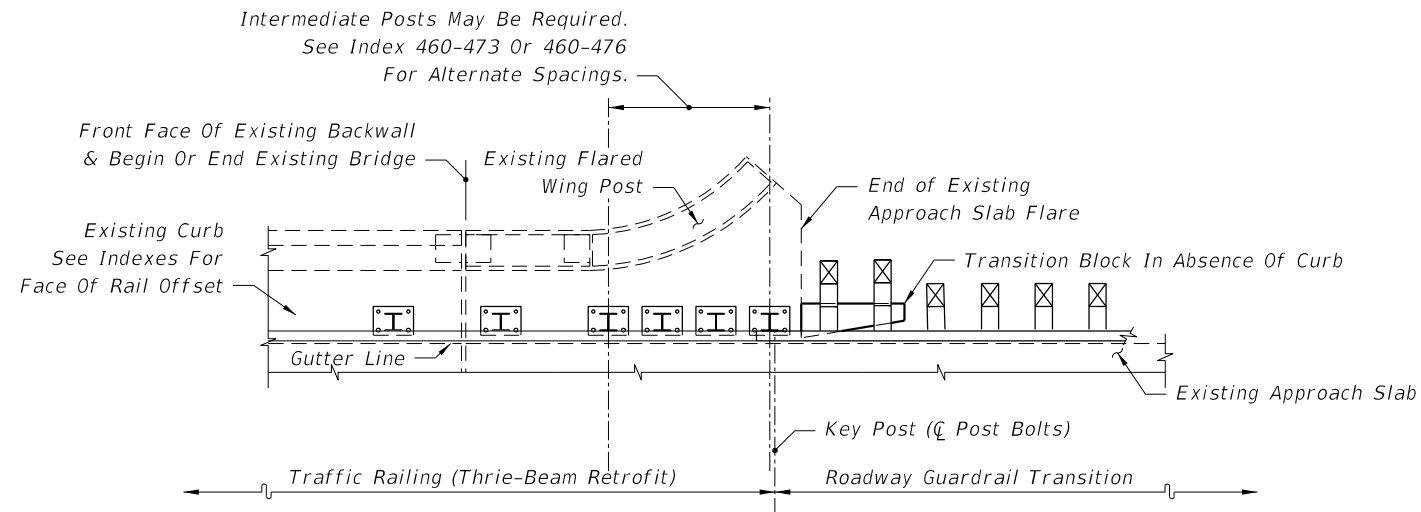

SEE INDEXES 460-473 & 460-476 - SCHEMES 5 & 6

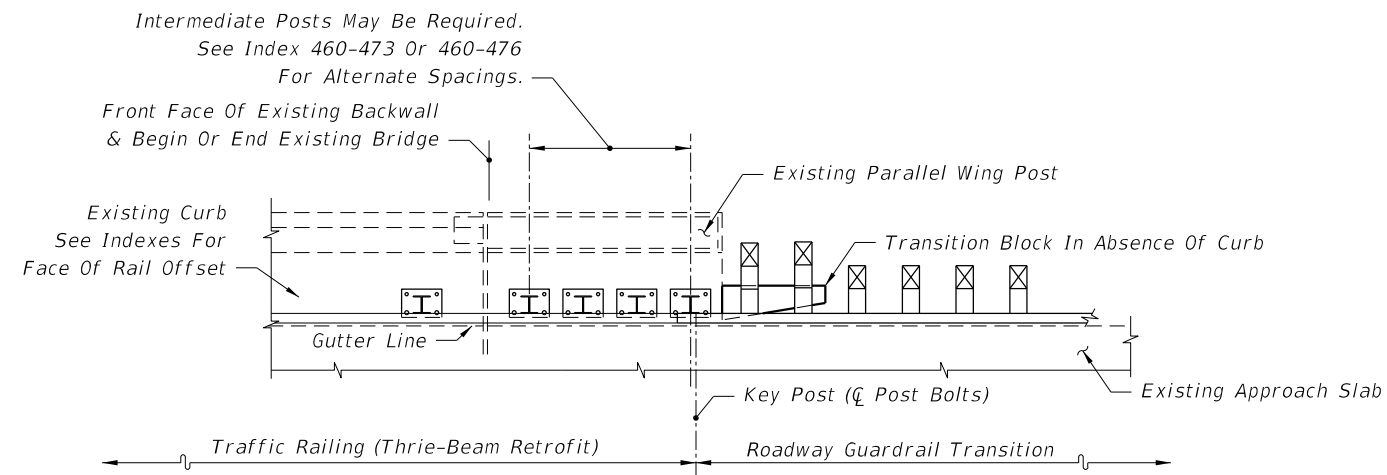

SEE INDEXES 460-473 & 460-476 - SCHEMES 5 & 6

PARTIAL PLAN VIEWS OF GUARDRAIL APPROACH TRANSITIONS AND CONNECTIONS
FOR BRIDGE TRAFFIC RAILING (THRIE-BEAM RETROFIT)

9/10/2024 1:54:13 PM

LAST REVISION 11/01/19	REVISION DESCRIPTION:	 FY 2025-26 STANDARD PLANS	GUARDRAIL TRANSITIONS AND CONNECTIONS FOR EXISTING BRIDGES	INDEX 536-002	SHEET 9 of 28
---------------------------	-----------------------	--	---	------------------	------------------

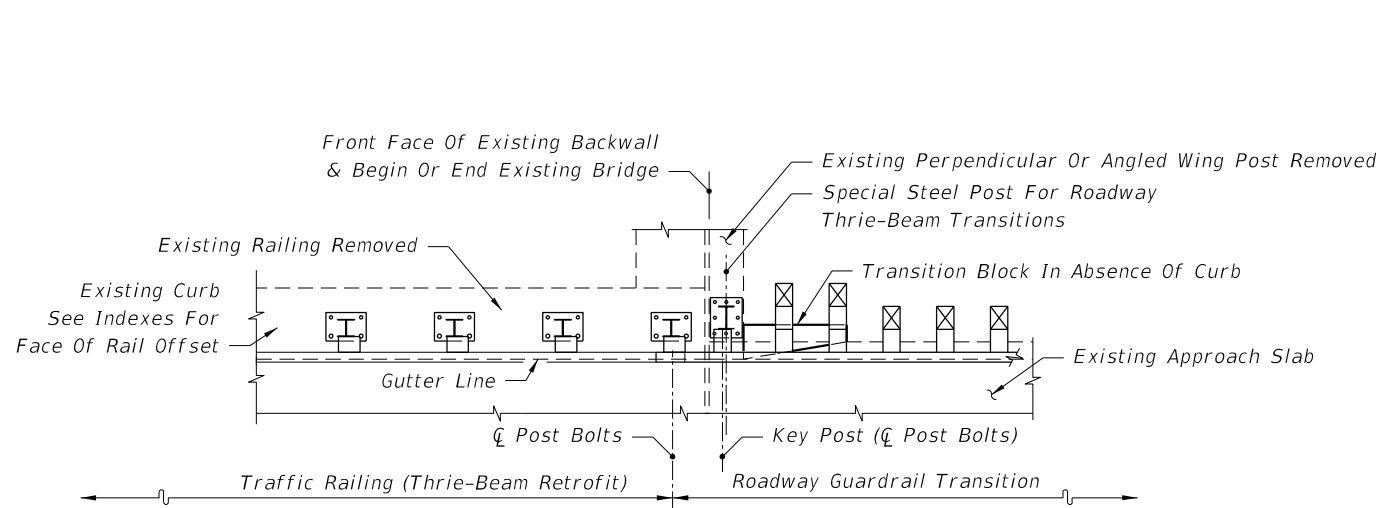

SEE INDEX 460-474 - SCHEME 1

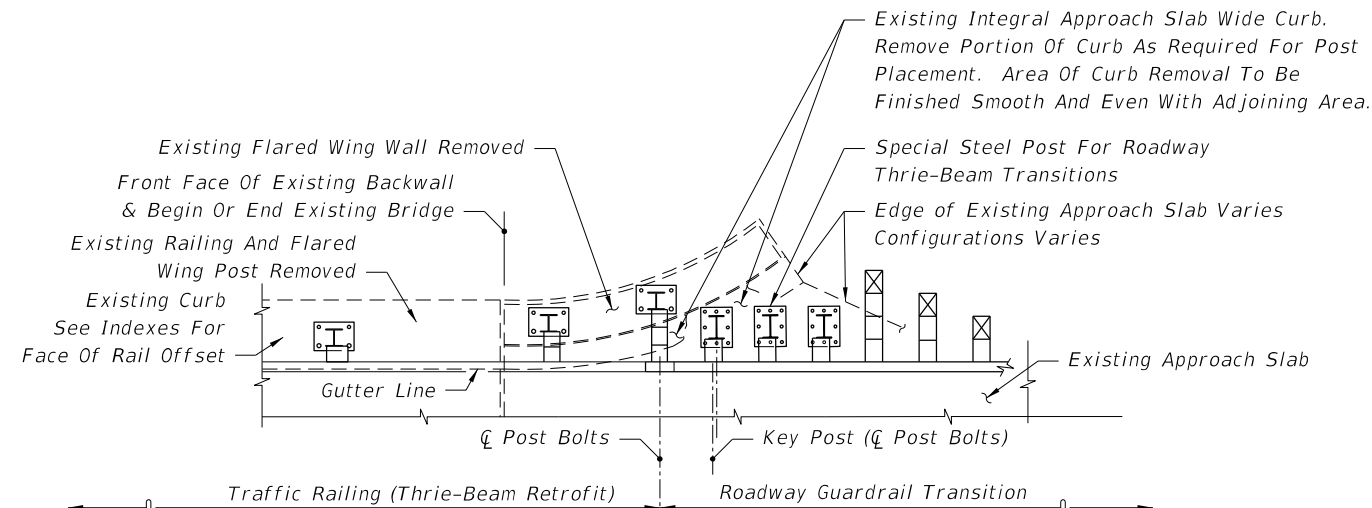

SEE INDEX 460-474 - SCHEME 3

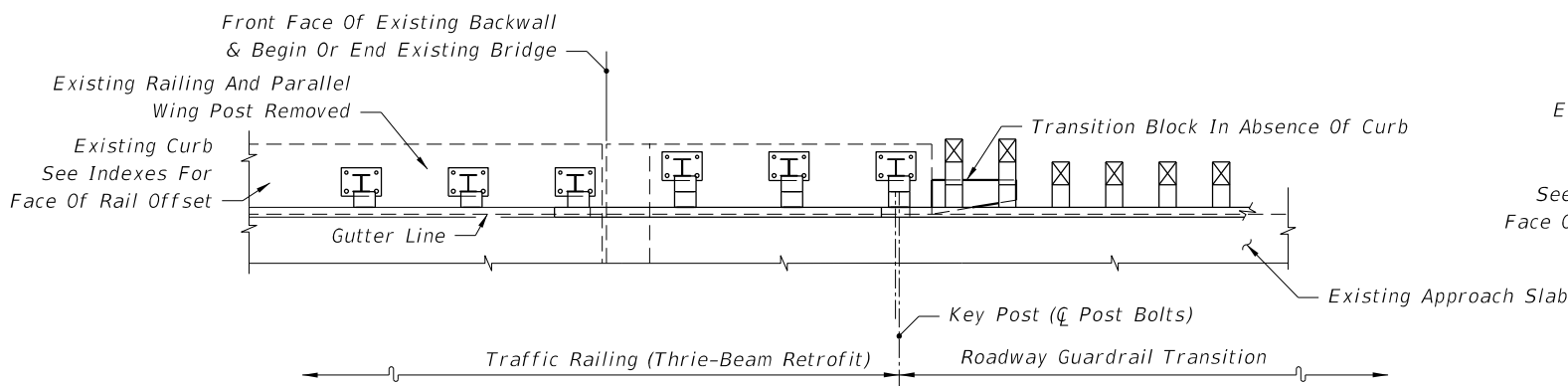

SEE INDEX 460-474 - SCHEME 2

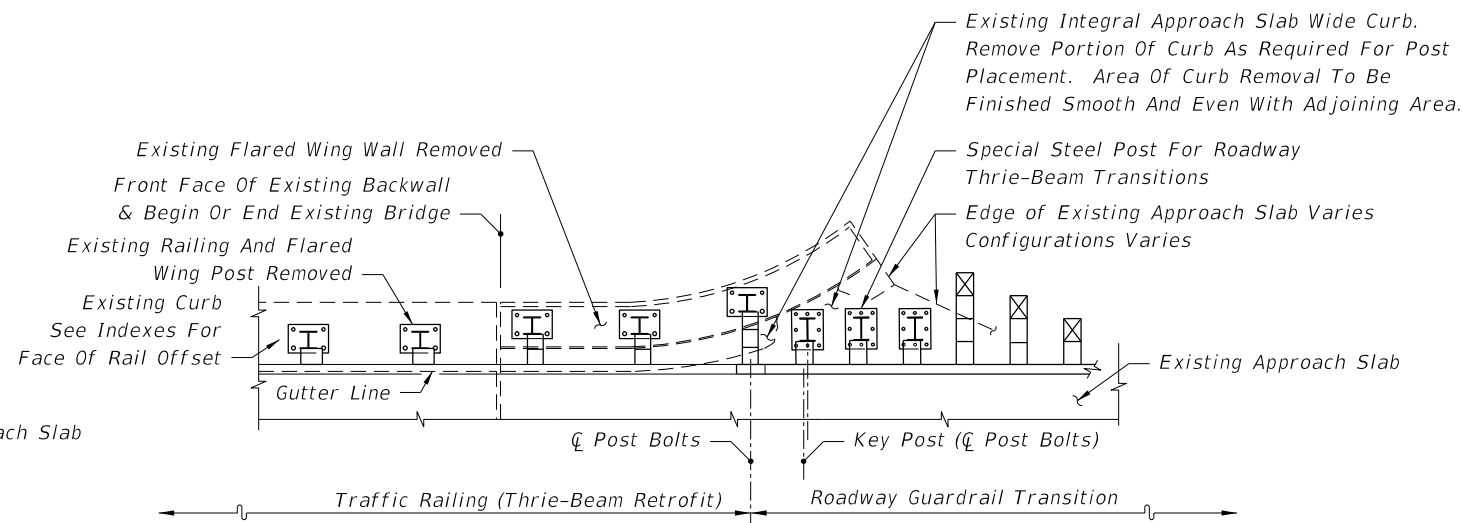

SEE INDEX 460-474 - SCHEME 3

PARTIAL PLAN VIEWS OF GUARDRAIL APPROACH TRANSITIONS AND CONNECTIONS FOR BRIDGE TRAFFIC RAILING (THRIE-BEAM RETROFIT)

9/10/2024 1:54:20 PM

LAST REVISION 11/01/19	REVISION	DESCRIPTION:	 FY 2025-26 STANDARD PLANS	GUARDRAIL TRANSITIONS AND CONNECTIONS FOR EXISTING BRIDGES	INDEX 536-002	SHEET 10 of 28
---------------------------	----------	--------------	---	---	------------------	-------------------

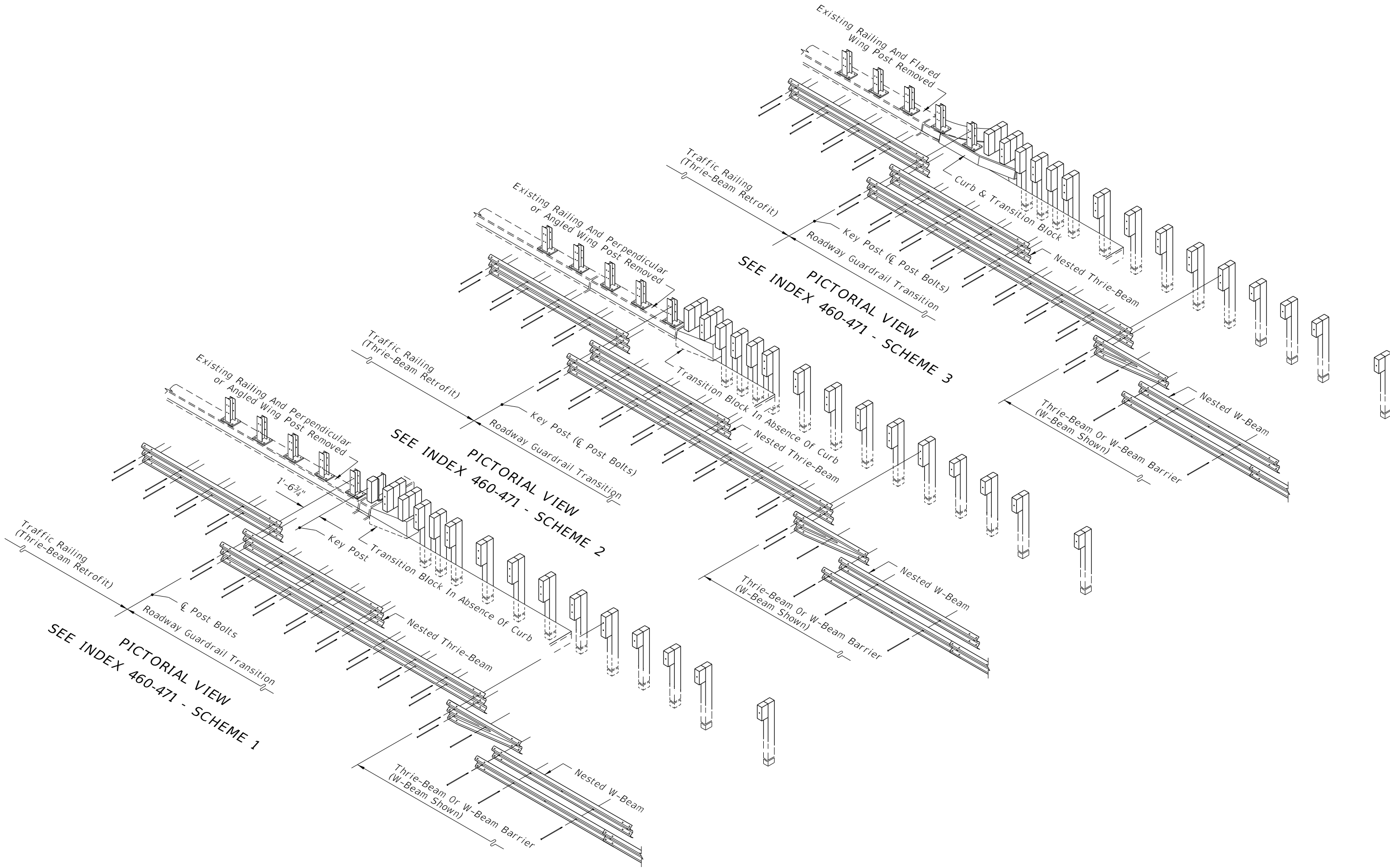

PICTORIAL VIEWS OF GUARDRAIL APPROACH TRANSITIONS AND CONNECTIONS FOR BRIDGE TRAFFIC RAILING (THRIE-BEAM RETROFIT)

9/10/2024 1:54:27 PM

LAST REVISION 11/01/19	REVISION DESCRIPTION:	 FY 2025-26 STANDARD PLANS	GUARDRAIL TRANSITIONS AND CONNECTIONS FOR EXISTING BRIDGES	INDEX 536-002	SHEET 11 of 28
---------------------------	-----------------------	---	--	------------------	-------------------

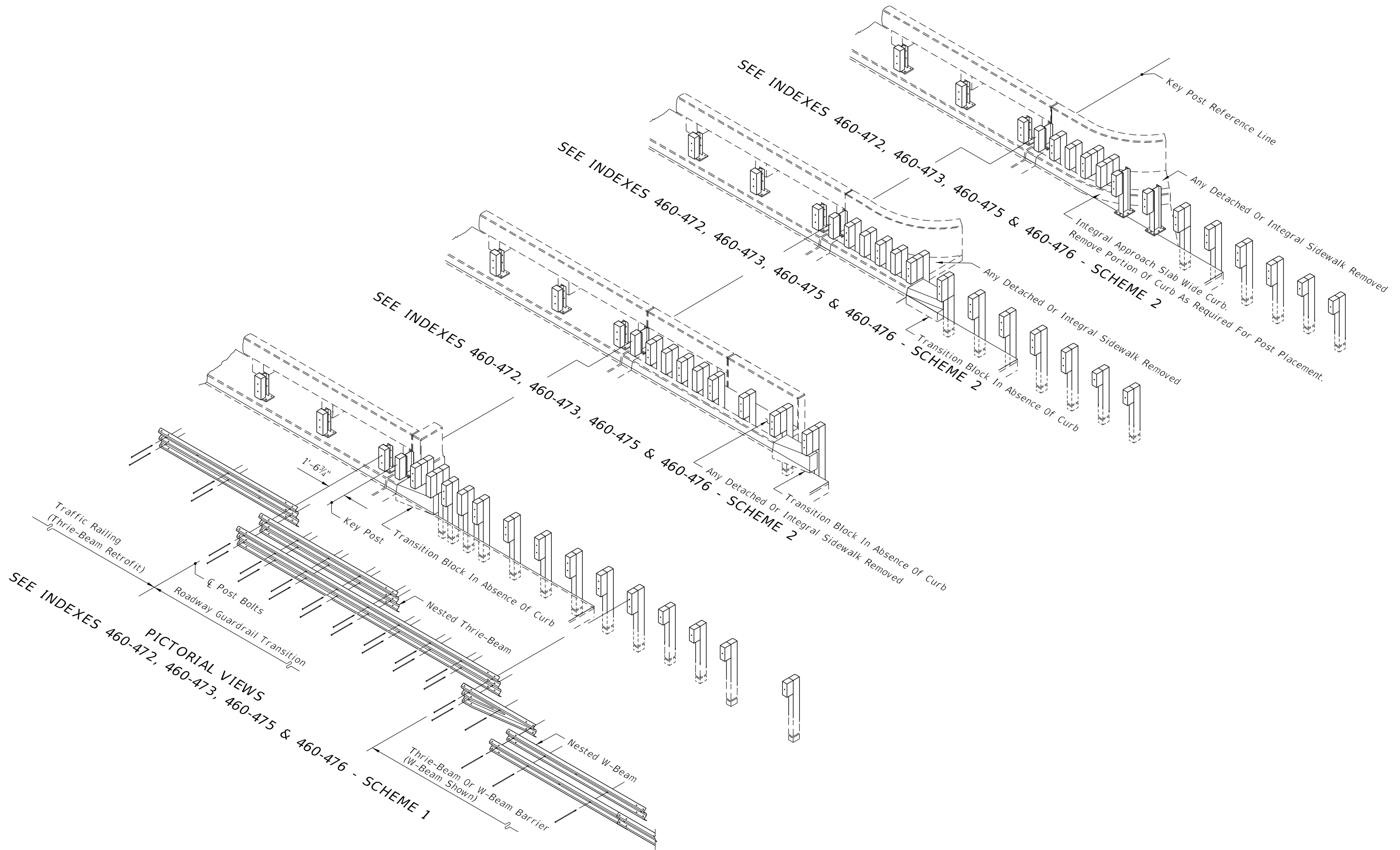

PICTORIAL VIEWS OF GUARDRAIL APPROACH TRANSITIONS AND CONNECTIONS FOR BRIDGE TRAFFIC RAILING (THRIE-BEAM RETROFIT)

9/10/2024 1:54:34 PM

LAST REVISION 11/01/19	DESCRIPTION: 	 FY 2025-26 STANDARD PLANS	GUARDRAIL TRANSITIONS AND CONNECTIONS FOR EXISTING BRIDGES	INDEX 536-002	SHEET 12 of 28
---------------------------	----------------------	--	--	------------------	-------------------

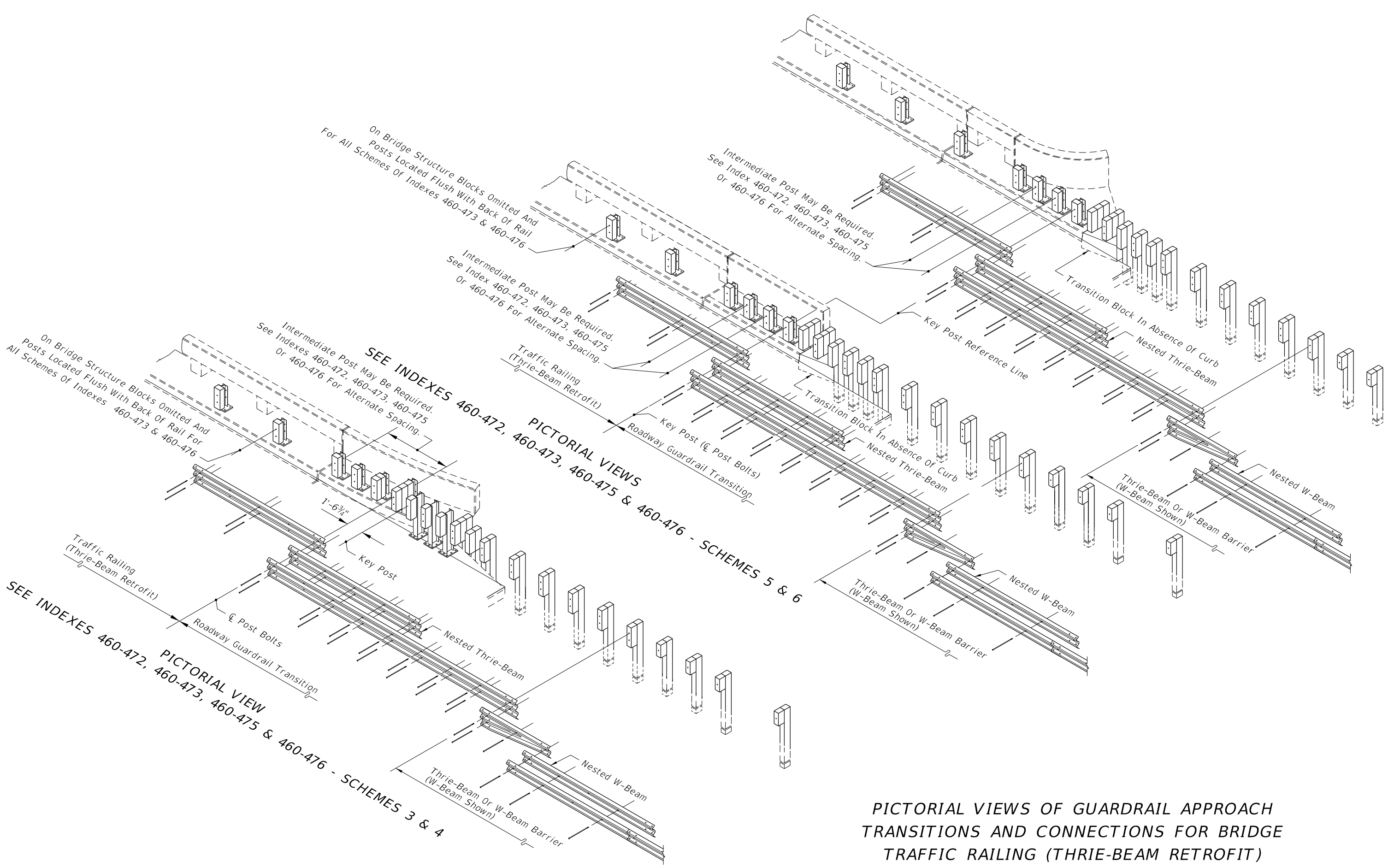

PICTORIAL VIEWS OF GUARDRAIL APPROACH TRANSITIONS AND CONNECTIONS FOR BRIDGE TRAFFIC RAILING (THRIE-BEAM RETROFIT)

9/10/2024 1:54:41 PM

LAST REVISION 11/01/19	DESCRIPTION:	 FY 2025-26 STANDARD PLANS	GUARDRAIL TRANSITIONS AND CONNECTIONS FOR EXISTING BRIDGES	INDEX 536-002	SHEET 13 of 28
---------------------------	--------------	---	--	------------------	-------------------

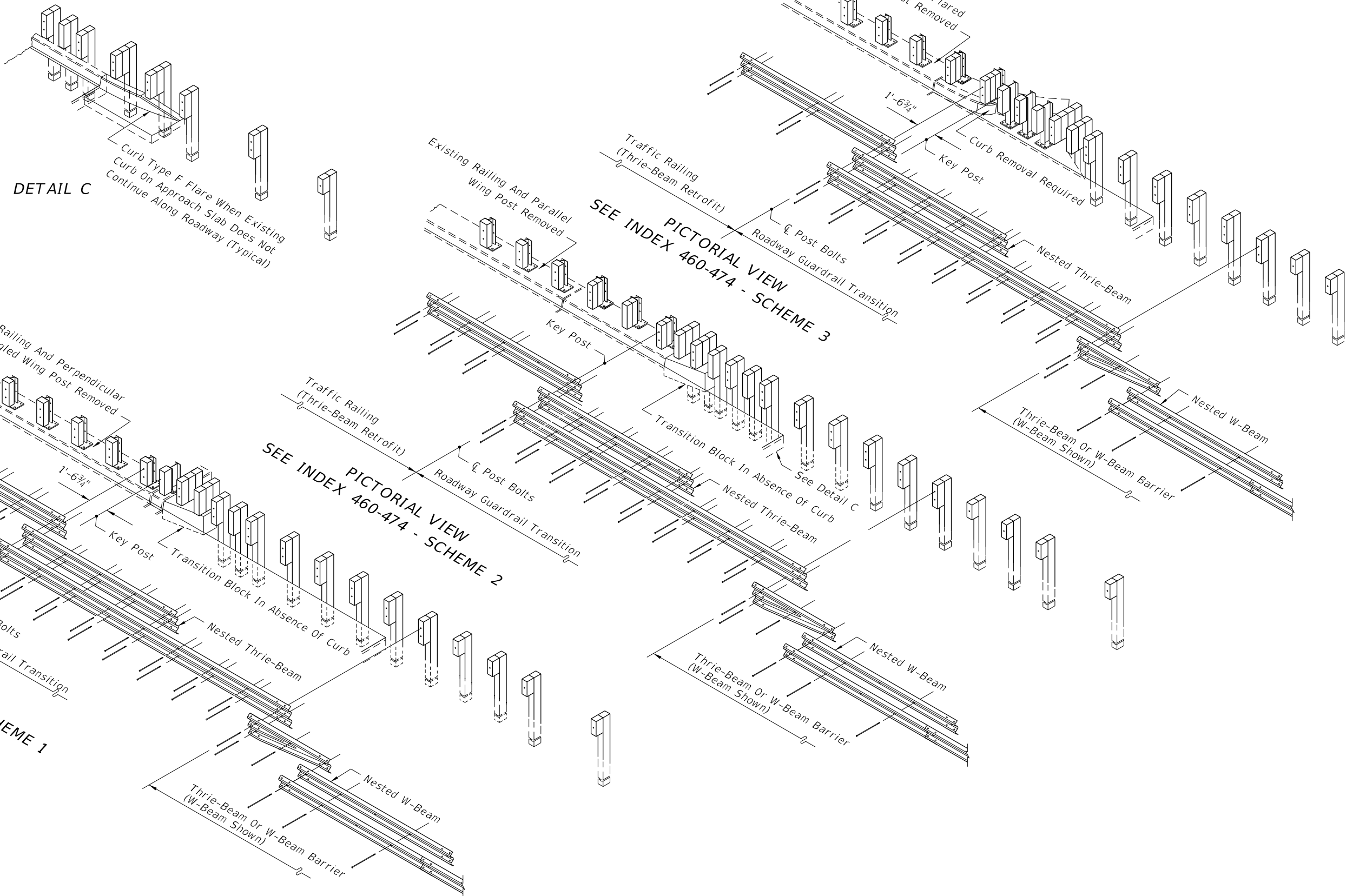

PICTORIAL VIEWS OF GUARDRAIL APPROACH TRANSITIONS AND CONNECTIONS FOR BRIDGE TRAFFIC RAILING (THRIE-BEAM RETROFIT)

9/10/2024 1:54:48 PM

LAST REVISION 11/01/19	DESCRIPTION:	 FY 2025-26 STANDARD PLANS	GUARDRAIL TRANSITIONS AND CONNECTIONS FOR EXISTING BRIDGES	INDEX 536-002	SHEET 14 of 28
---------------------------	--------------	--	--	------------------	-------------------

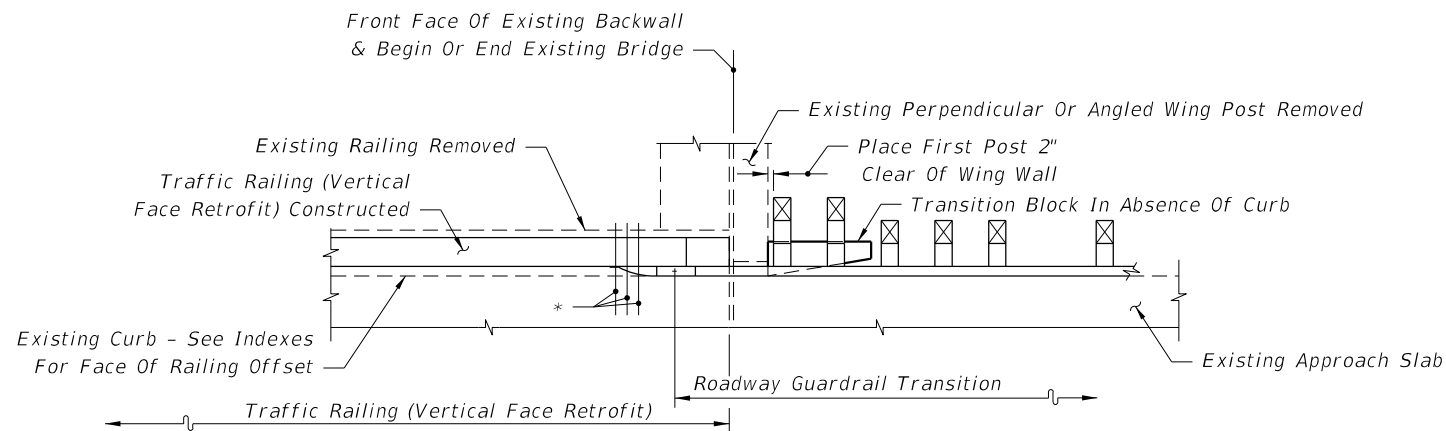

SEE INDEX 521-481 - SCHEME 1

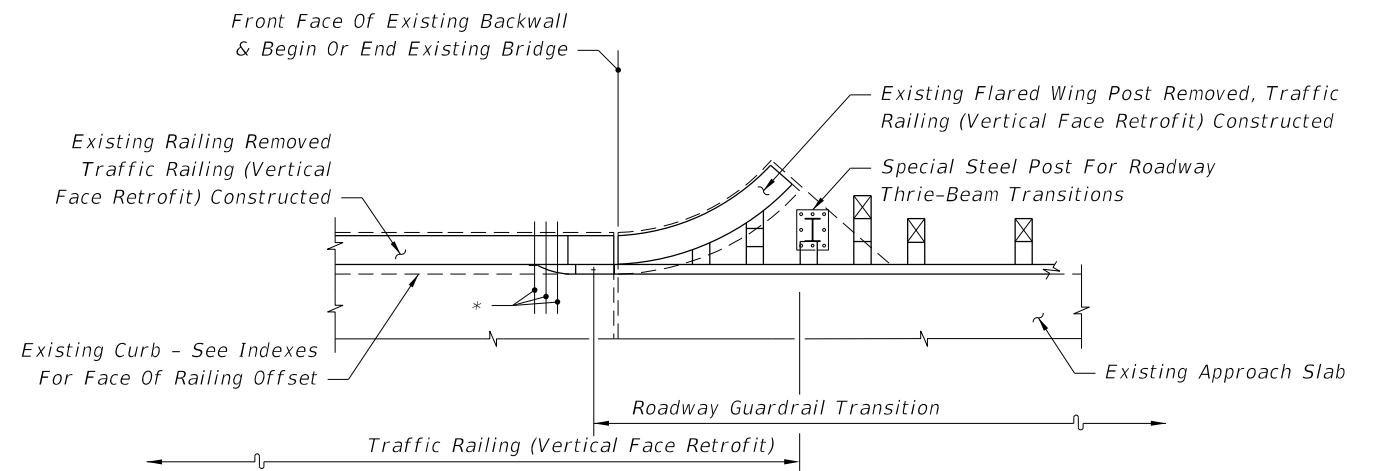

SEE INDEX 521-481 - SCHEME 3

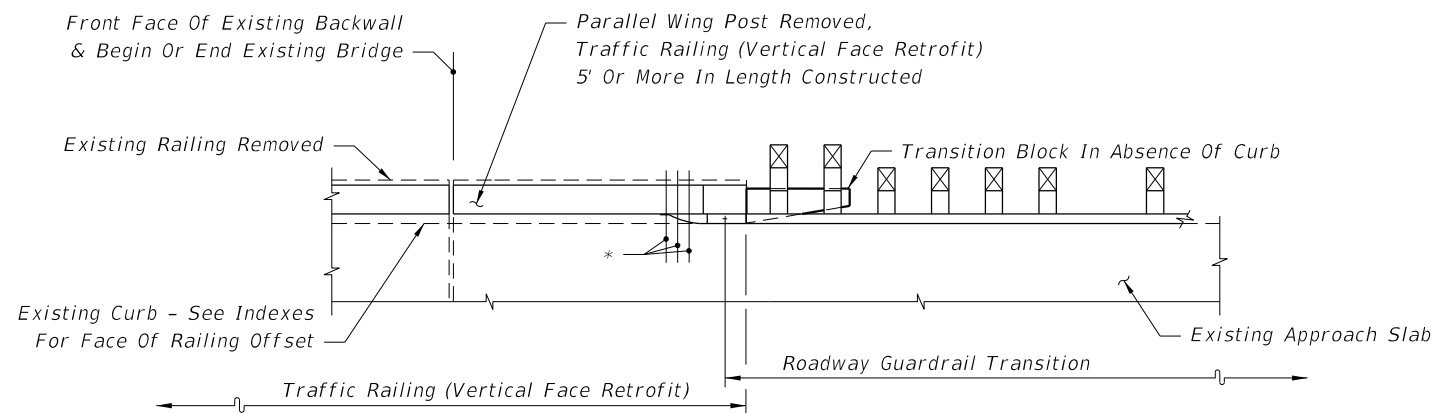

SEE INDEX 521-481 - SCHEME 2

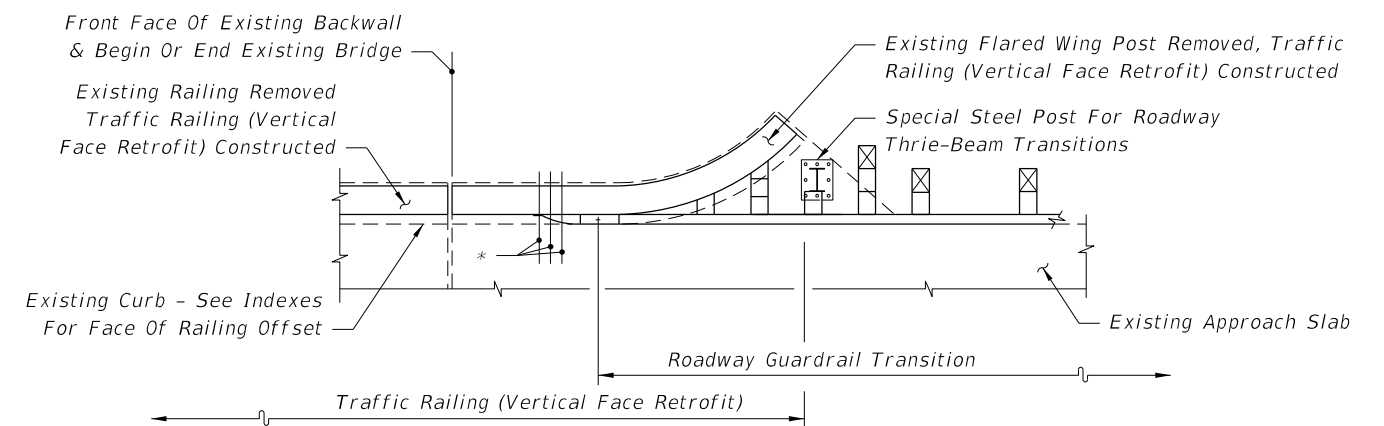

SEE INDEX 521-481 - SCHEME 3

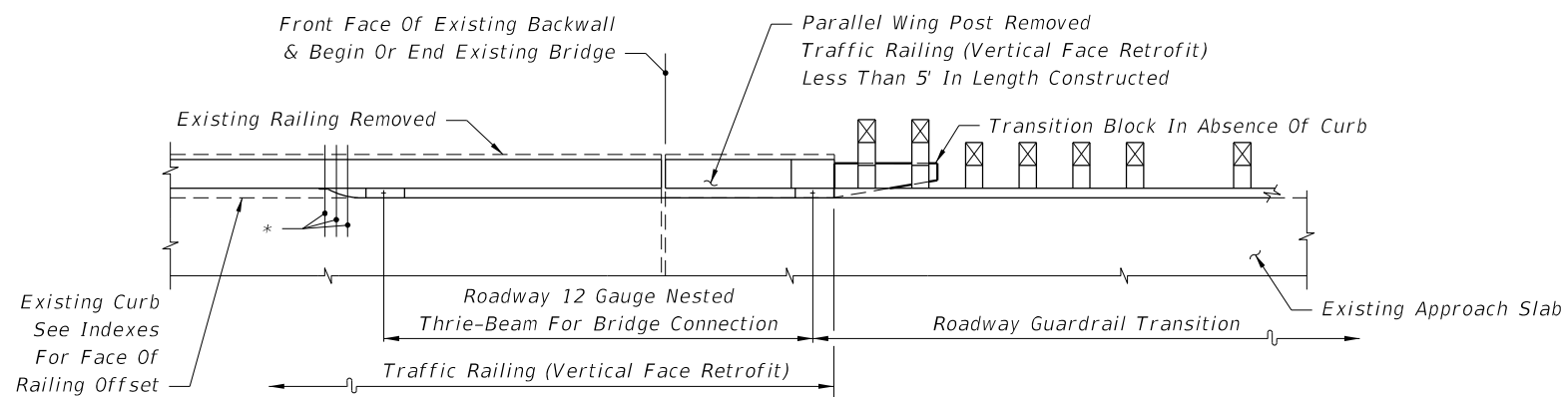

SEE INDEX 521-481 - SCHEME 2

Note:
 * 21" x 12" x 5/8" Thrie-Beam Terminal Connector Plate (Back-Up Plate), And 7/8"Ø x 12" Long HS
 Hex Bolts And Nuts (5 Reqd.) With 2 1/4" OD Plain Round Washers Under Heads And Nuts

PARTIAL PLAN VIEWS OF TRAFFIC RAILING (VERTICAL FACE RETROFIT)

9/10/2024 1:54:55 PM

LAST REVISION 11/01/19	REVISION	DESCRIPTION:		FY 2025-26 STANDARD PLANS	GUARDRAIL TRANSITIONS AND CONNECTIONS FOR EXISTING BRIDGES	INDEX 536-002	SHEET 15 of 28
---------------------------	----------	--------------	---	------------------------------	---	------------------	-------------------

9/10/2024 1:55:02 PM

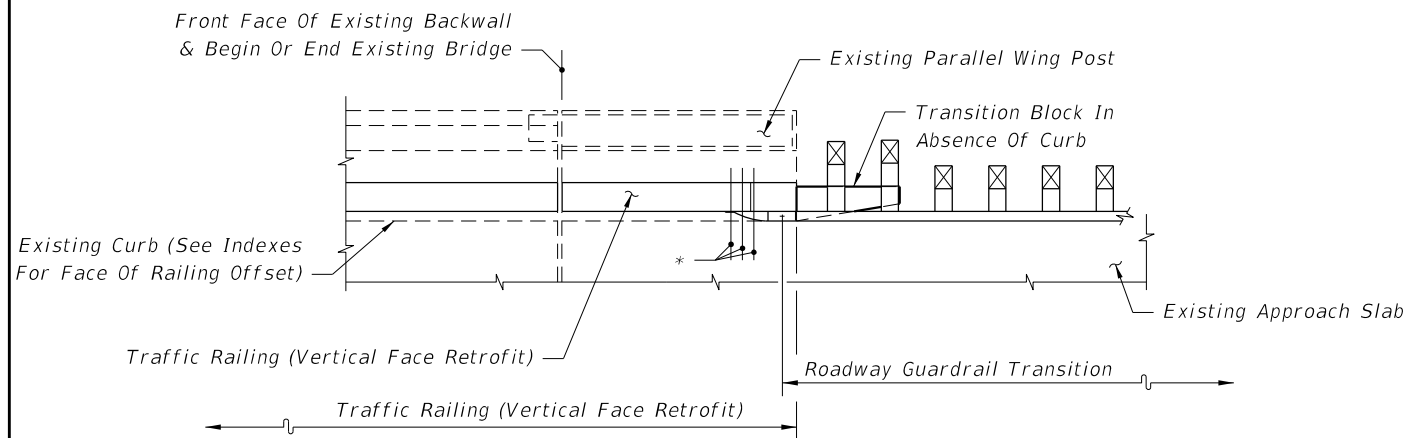

SEE INDEX 521-405 OR 521-482 - SCHEME 2

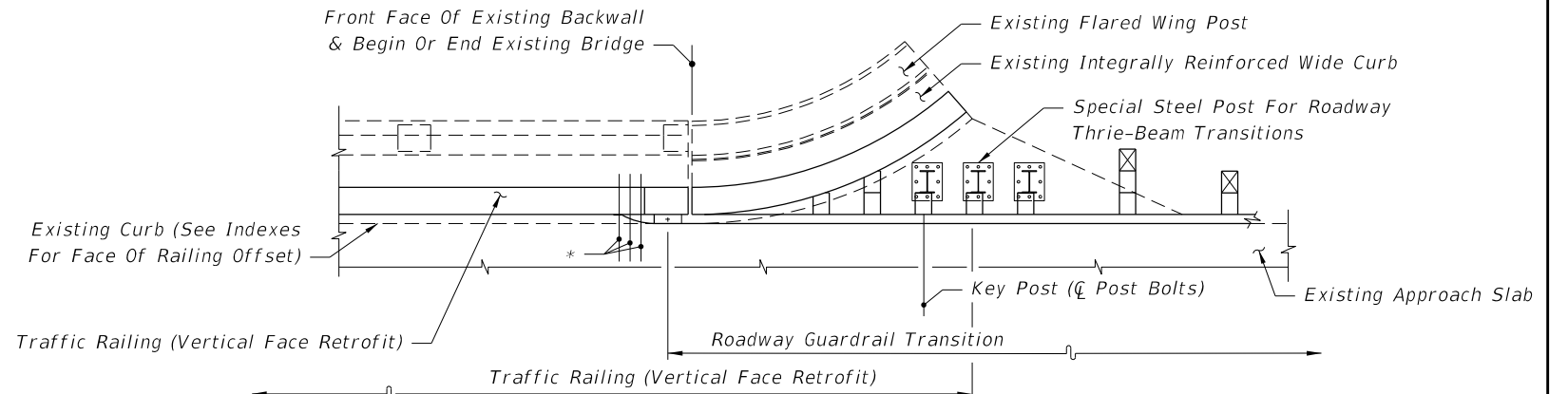

SEE INDEX 521-405 OR 521-482 - SCHEME 3

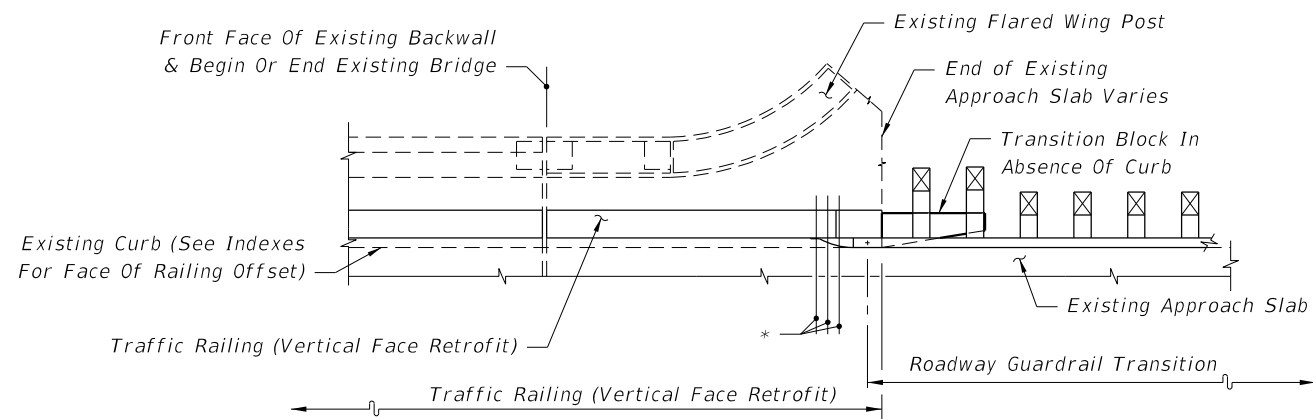

SEE INDEX 521-405 OR 521-482 - SCHEME 2

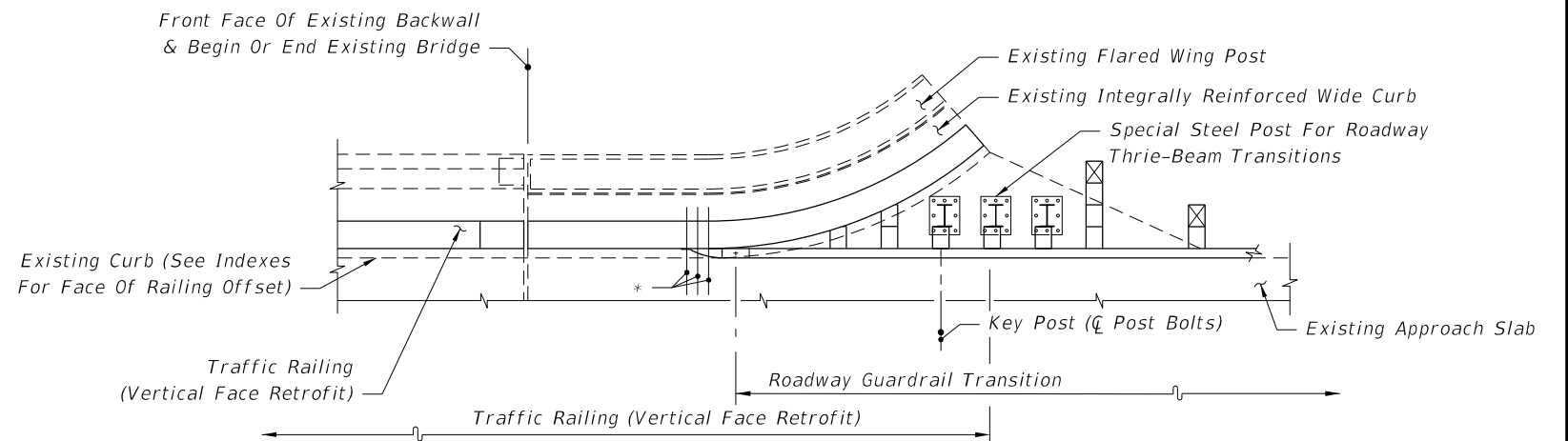

SEE INDEX 521-405 OR 521-482 - SCHEME 3

Note:
 * 21" x 12" x 5/8" Thrie-Beam Terminal Connector Plate (Back-Up Plate), And 7/8"Ø x 12" Long
 HS Hex Bolts And Nuts (5 Reqd.) With 2 1/4" OD Plain Round Washers Under Heads And Nuts

**PARTIAL PLAN VIEWS OF TRAFFIC RAILING (VERTICAL FACE RETROFIT)
 (INDEX 521-482 SHOWN, INDEX 521-405 SIMILAR)**

LAST REVISION 11/01/19	REVISION	DESCRIPTION:		FY 2025-26 STANDARD PLANS	GUARDRAIL TRANSITIONS AND CONNECTIONS FOR EXISTING BRIDGES	INDEX 536-002	SHEET 16 of 28
---------------------------	----------	--------------	---	------------------------------	---	------------------	-------------------

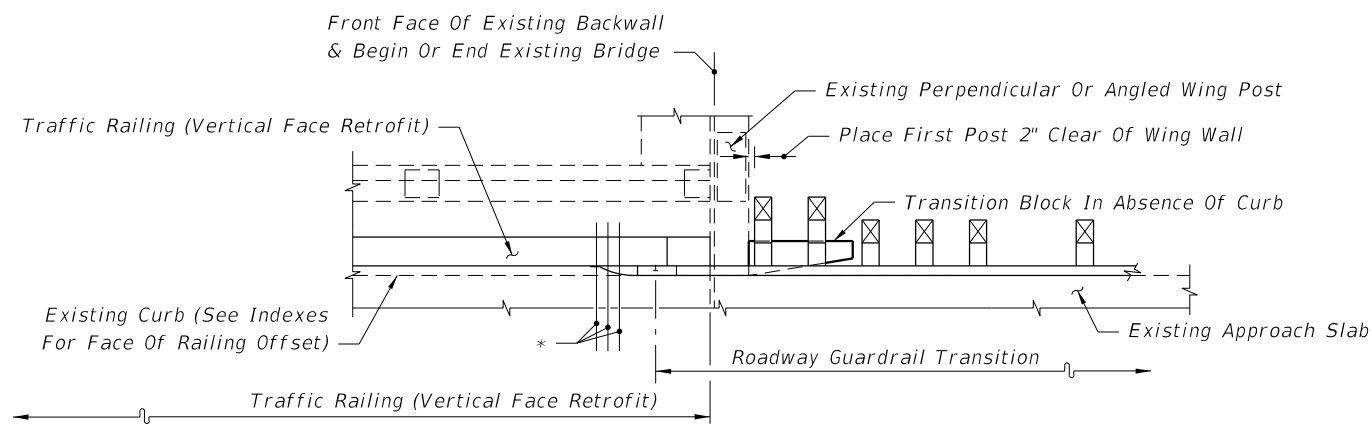

SEE INDEX 521-405 OR 521-482 - SCHEME 1

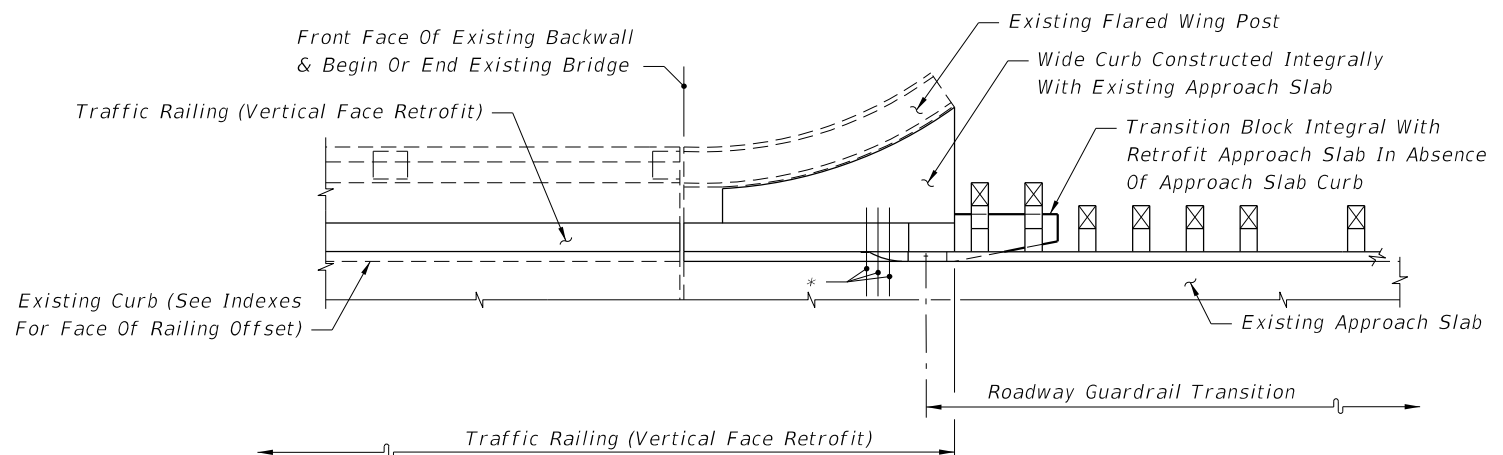

SEE INDEX 521-405 OR 521-482 - SCHEME 5

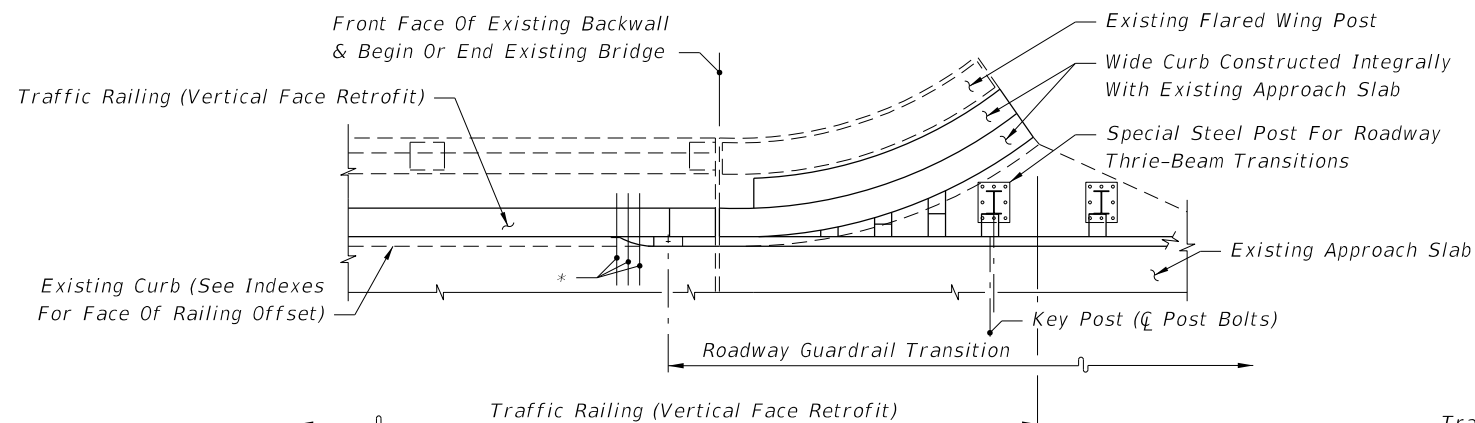

SEE INDEX 521-405 OR 521-482 - SCHEME 4

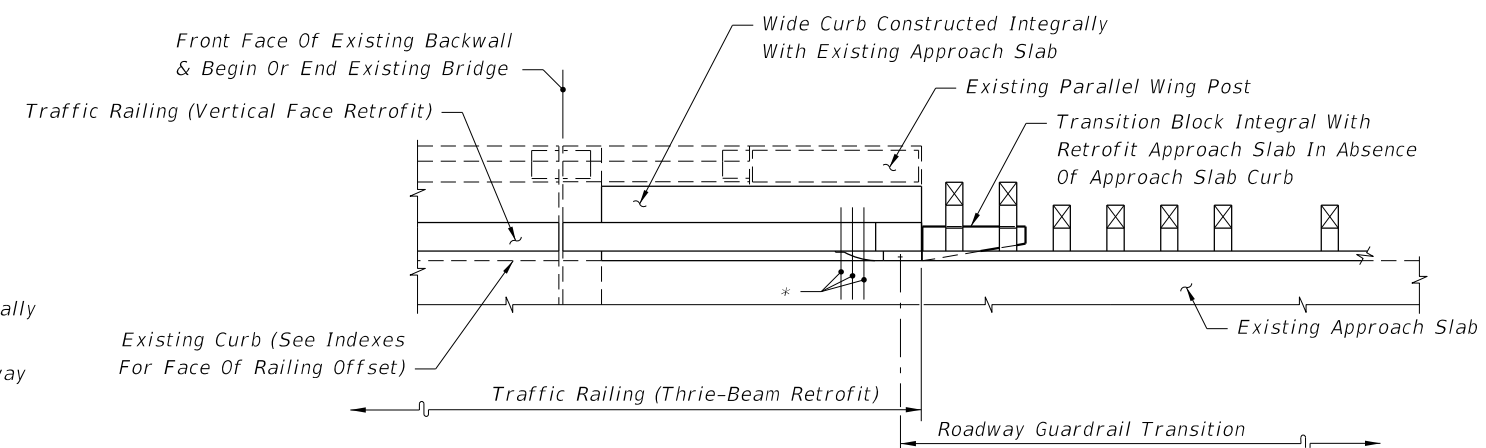

SEE INDEX 521-405 OR 521-482 - SCHEME 5

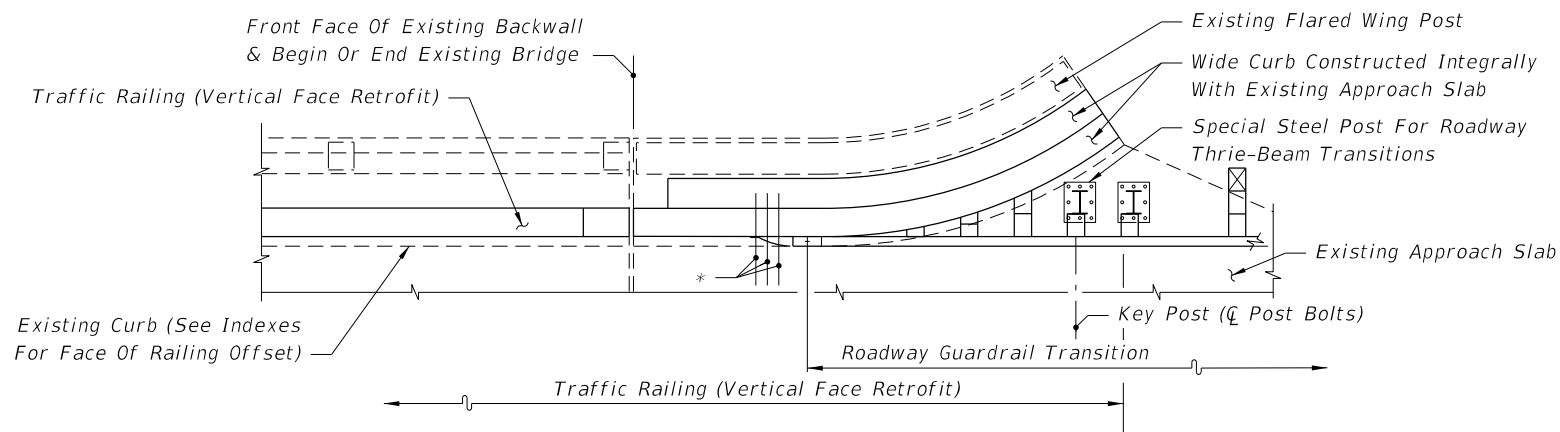

SEE INDEX 521-405 OR 521-482 - SCHEME 4

Note:
 *21" x 12" x 5/8" Thrie-Beam Terminal Connector Plate (Back-Up Plate), And 7/8"Ø x 12" Long HS Hex Bolts And Nuts (5 Req'd.) With 2 1/4" OD Plain Round Washers Under Heads And Nuts

PARTIAL PLAN VIEWS OF TRAFFIC RAILING (VERTICAL FACE RETROFIT)
 (INDEX 521-482 SHOWN, INDEX 521-405 SIMILAR)

9/10/2024 1:55:11 PM

LAST REVISION 11/01/19	REVISION	DESCRIPTION:		FY 2025-26 STANDARD PLANS	GUARDRAIL TRANSITIONS AND CONNECTIONS FOR EXISTING BRIDGES	INDEX 536-002	SHEET 17 of 28
---------------------------	----------	--------------	---	------------------------------	---	------------------	-------------------

9/10/2024 1:55:17 PM

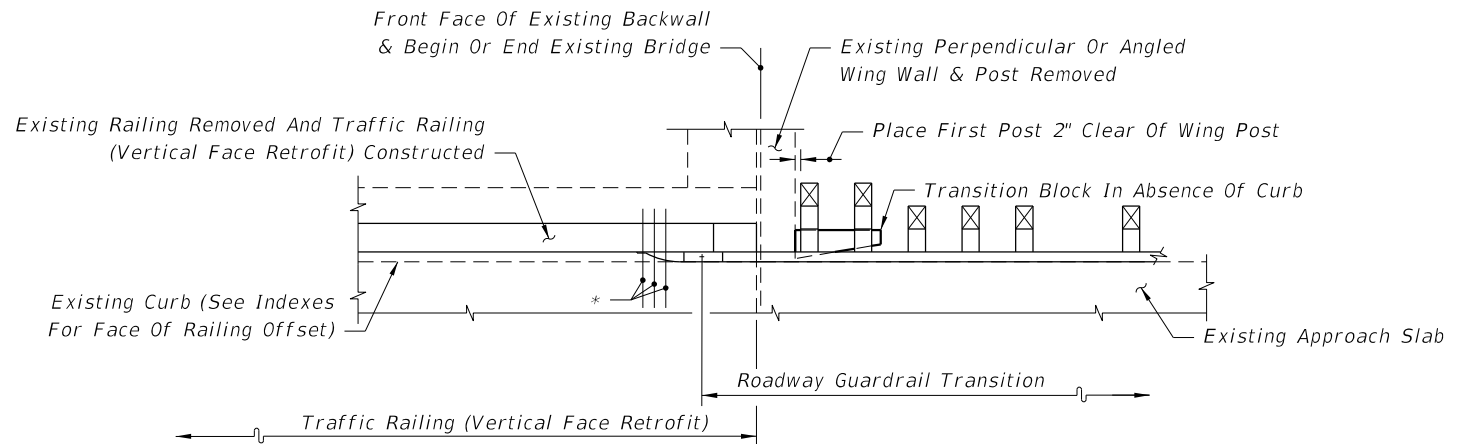

SEE INDEX 521-483 - SCHEME 1

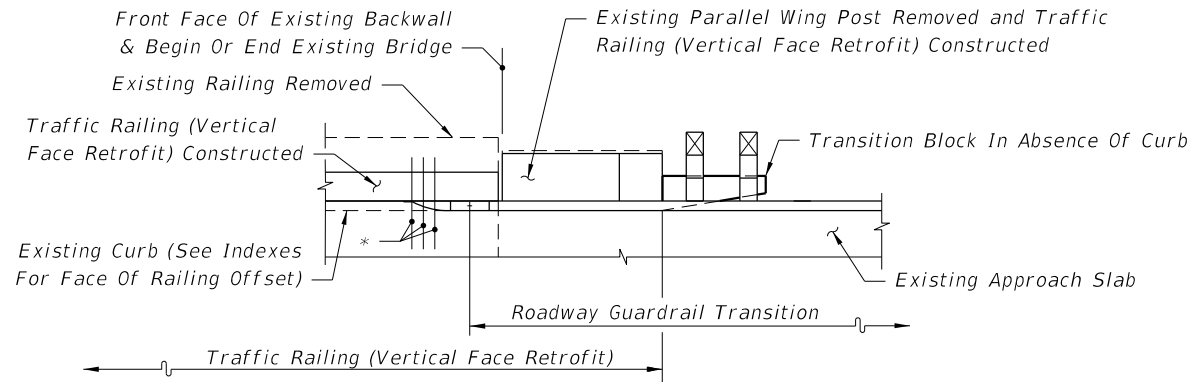

SEE INDEX 521-483 - SCHEME 2

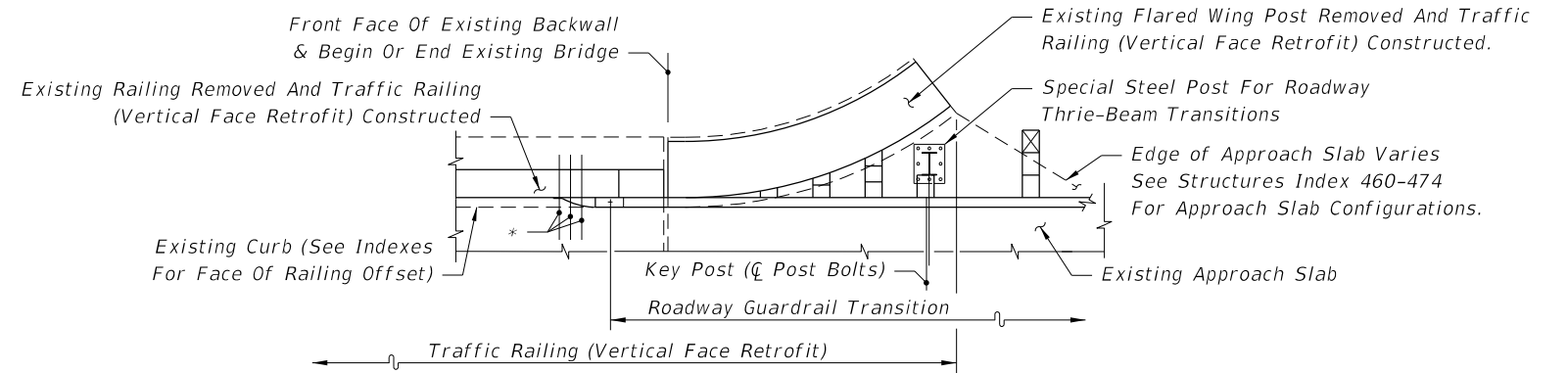

SEE INDEX 521-483 - SCHEME 3

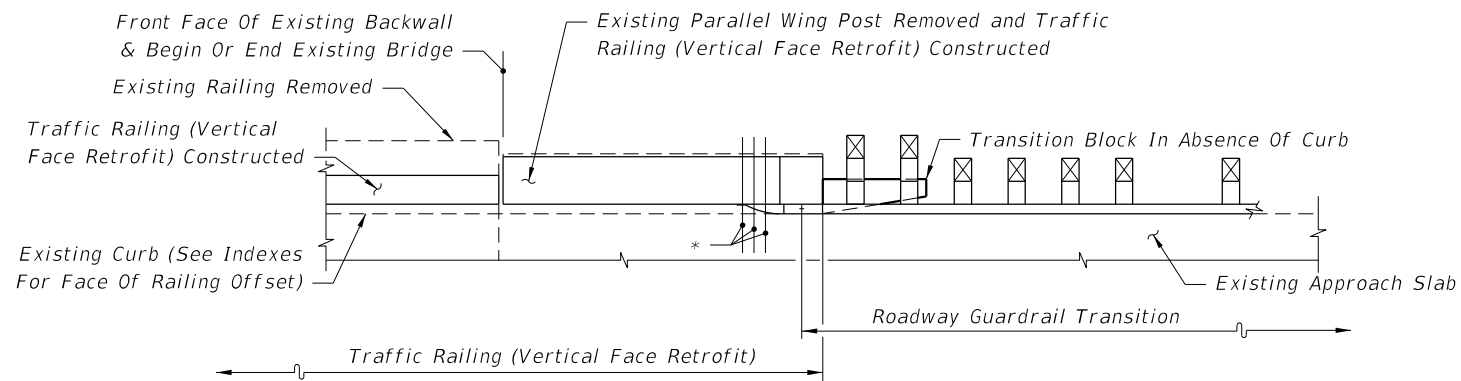

SEE INDEX 521-483 - SCHEME 2

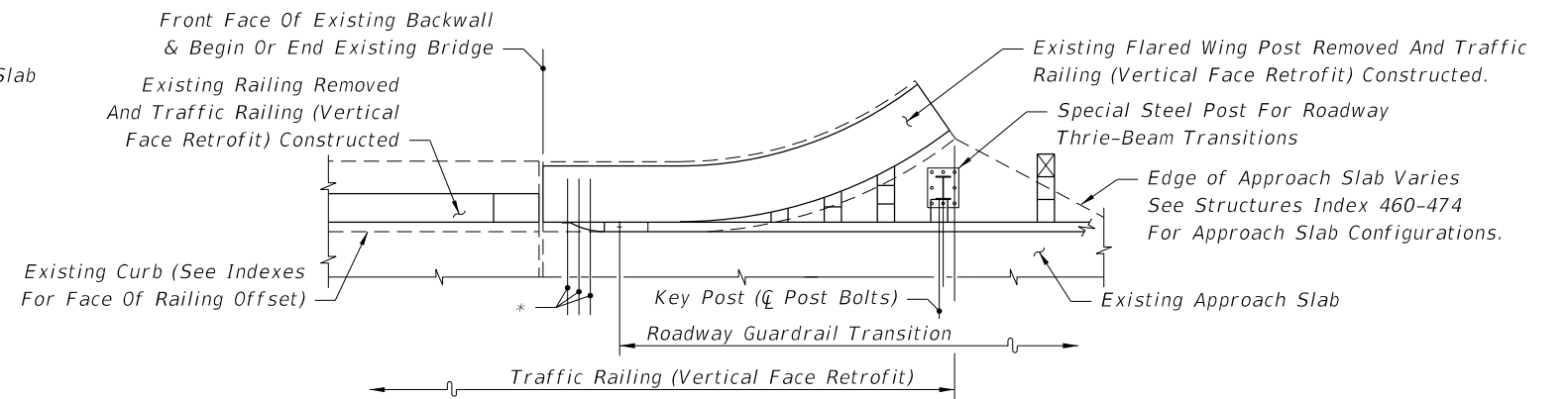

SEE INDEX 521-483 - SCHEME 3

Note:

* 21" x 12" x 5/8" Thrie-Beam Terminal Connector Plate (Back-Up Plate), And 7/8"Ø HS Hex Bolts And Nuts (12" Long For Scheme 1 And Length To Fit For Schemes 2 And 3) (5 Req'd.) With 2 1/4" OD Plain Round Washers Under Heads And Nuts

PARTIAL PLAN VIEWS OF TRAFFIC RAILING (VERTICAL FACE RETROFIT)

LAST REVISION 11/01/19	REVISION DESCRIPTION:	 FY 2025-26 STANDARD PLANS	GUARDRAIL TRANSITIONS AND CONNECTIONS FOR EXISTING BRIDGES	INDEX 536-002	SHEET 18 of 28
---------------------------	--------------------------	--	---	------------------	-------------------

9/10/2024 1:56:07 PM

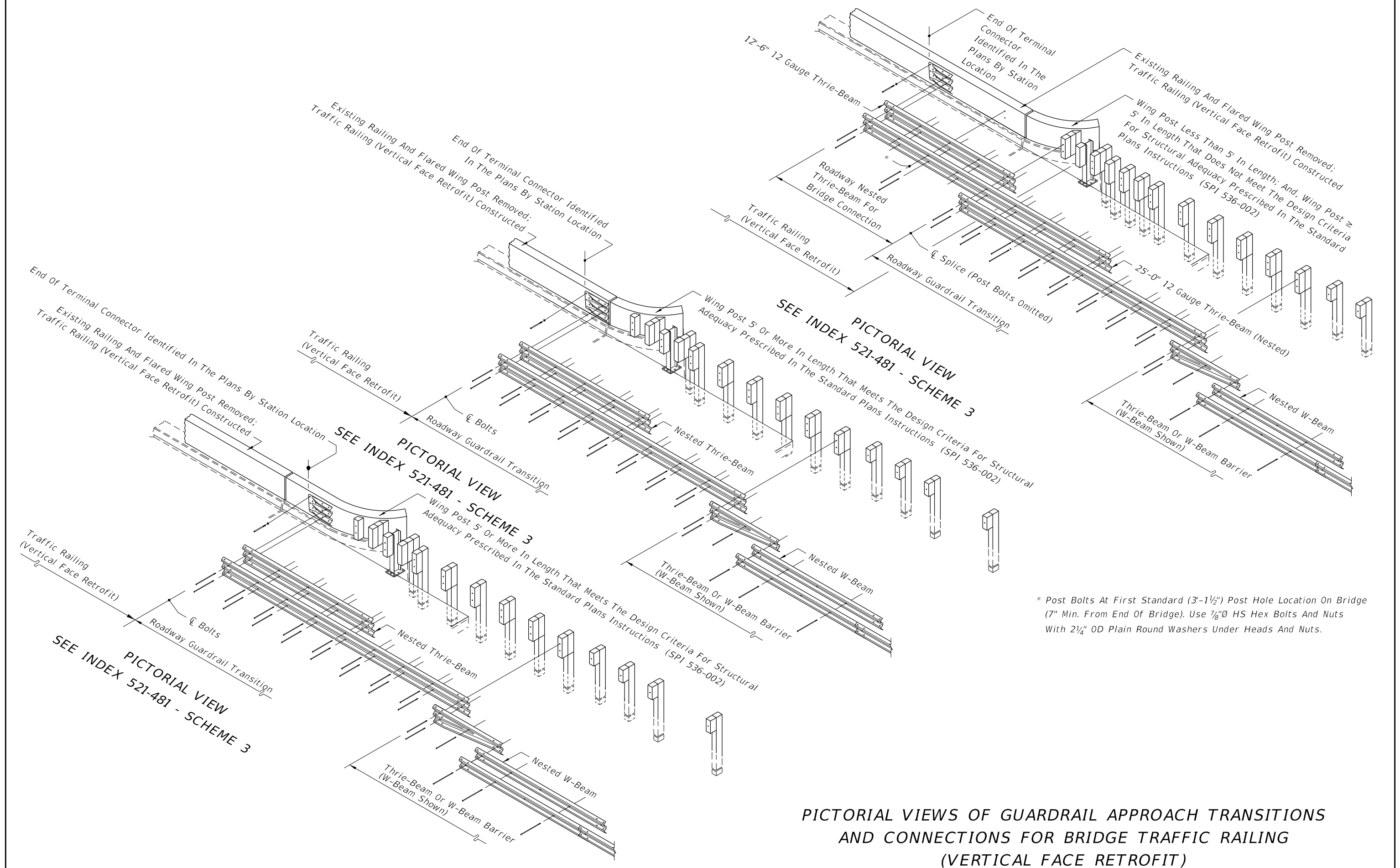

* Post Bolts At First Standard (3'-1 1/2") Post Hole Location On Bridge (7" Min. From End Of Bridge). Use 7/8"Ø HS Hex Bolts And Nuts With 2 1/4" OD Plain Round Washers Under Heads And Nuts.

PICTORIAL VIEWS OF GUARDRAIL APPROACH TRANSITIONS AND CONNECTIONS FOR BRIDGE TRAFFIC RAILING (VERTICAL FACE RETROFIT)

LAST REVISION 11/01/19	DESCRIPTION: 	 FY 2025-26 STANDARD PLANS	GUARDRAIL TRANSITIONS AND CONNECTIONS FOR EXISTING BRIDGES	INDEX 536-002	SHEET 20 of 28
---------------------------	----------------------	---	--	------------------	-------------------

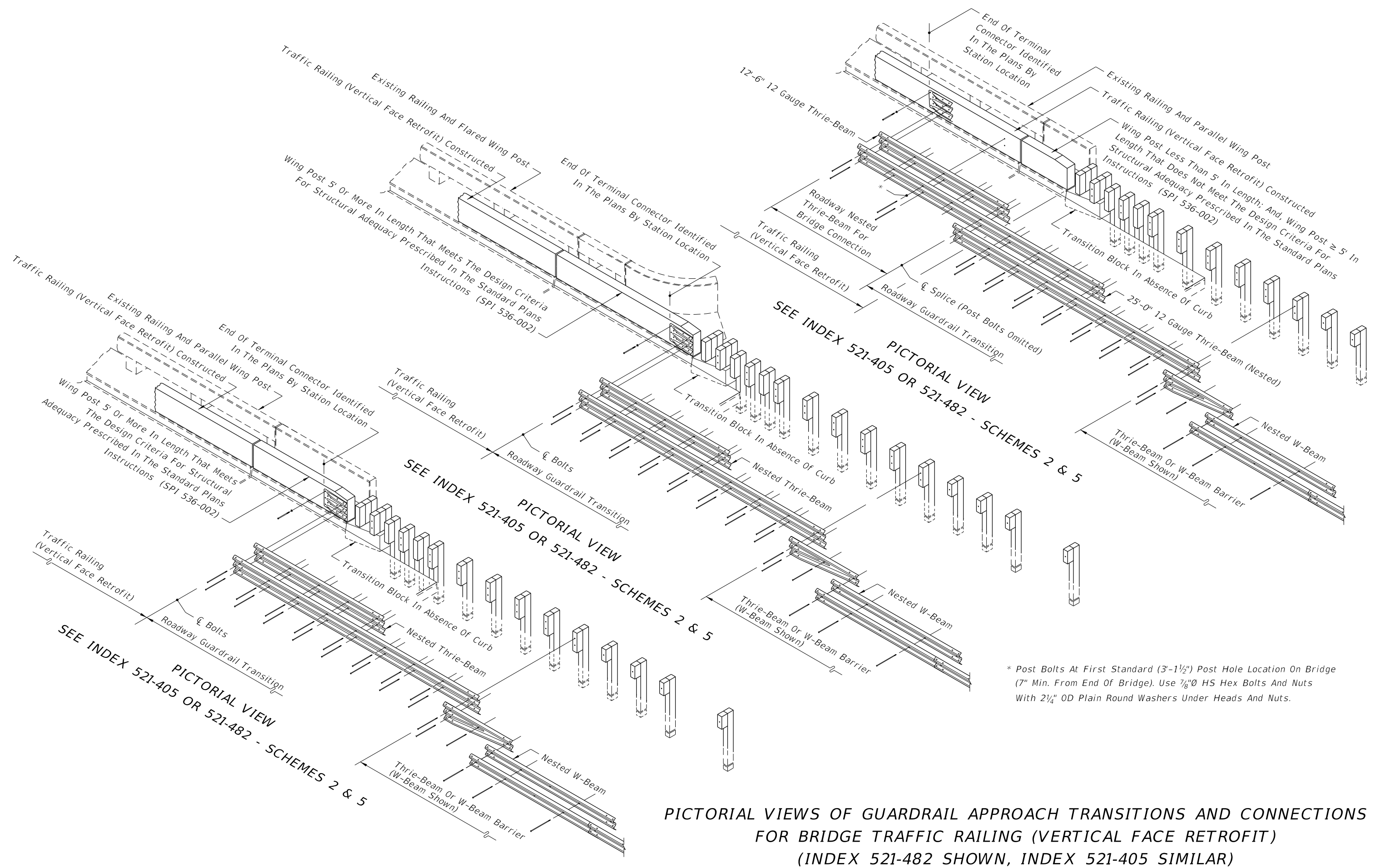

PICTORIAL VIEWS OF GUARDRAIL APPROACH TRANSITIONS AND CONNECTIONS FOR BRIDGE TRAFFIC RAILING (VERTICAL FACE RETROFIT) (INDEX 521-482 SHOWN, INDEX 521-405 SIMILAR)

9/10/2024 1:56:16 PM

LAST REVISION 11/01/19	REVISION	DESCRIPTION:	 FY 2025-26 STANDARD PLANS	GUARDRAIL TRANSITIONS AND CONNECTIONS FOR EXISTING BRIDGES	INDEX 536-002	SHEET 21 of 28
---------------------------	----------	--------------	--	---	------------------	-------------------

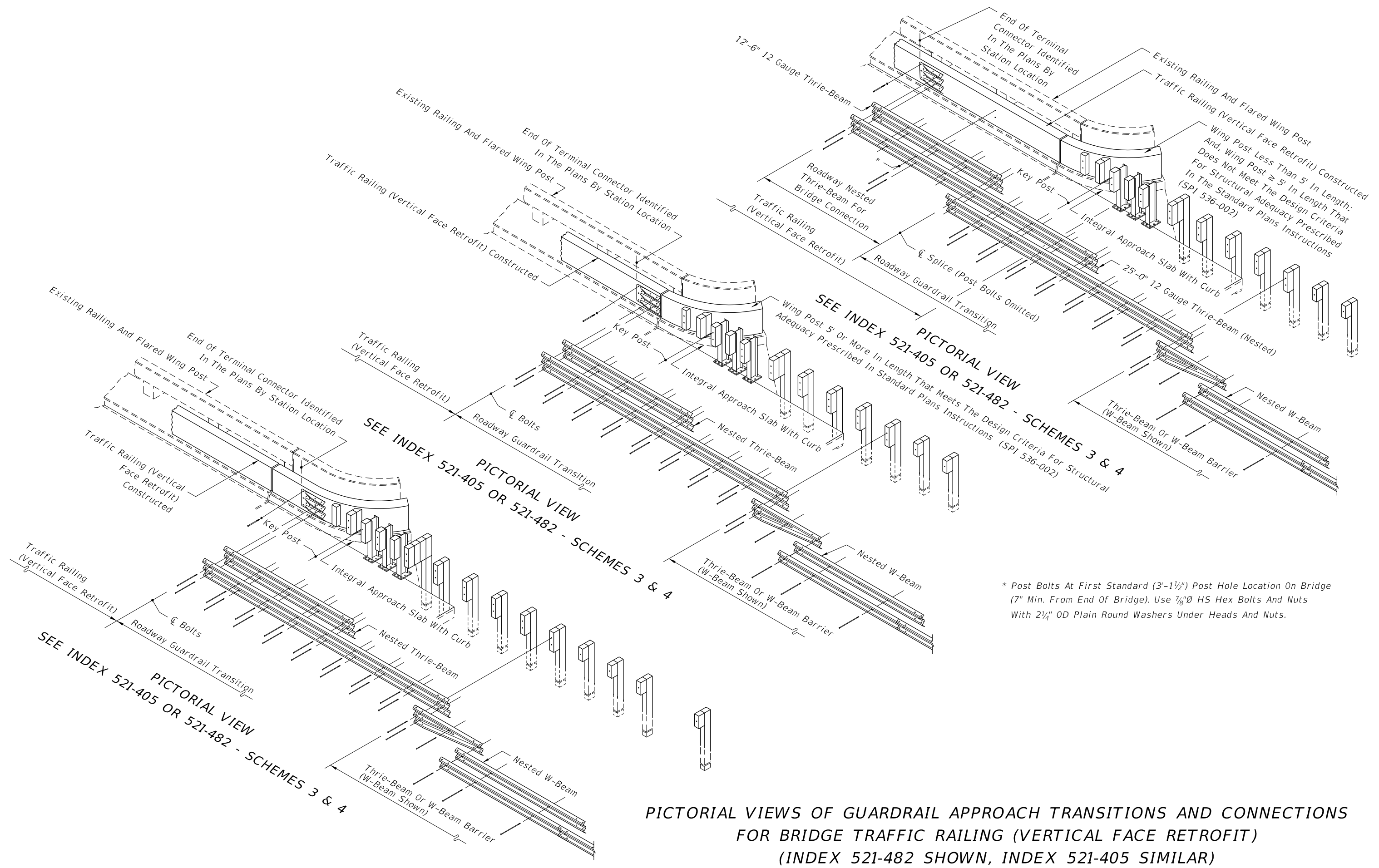

* Post Bolts At First Standard (3'-1 1/2") Post Hole Location On Bridge (7" Min. From End Of Bridge). Use 7/8" Ø HS Hex Bolts And Nuts With 2 1/4" OD Plain Round Washers Under Heads And Nuts.

PICTORIAL VIEWS OF GUARDRAIL APPROACH TRANSITIONS AND CONNECTIONS FOR BRIDGE TRAFFIC RAILING (VERTICAL FACE RETROFIT) (INDEX 521-482 SHOWN, INDEX 521-405 SIMILAR)

9/10/2024 1:56:23 PM

LAST REVISION 11/01/19	REVISION	DESCRIPTION:	 FY 2025-26 STANDARD PLANS	GUARDRAIL TRANSITIONS AND CONNECTIONS FOR EXISTING BRIDGES	INDEX 536-002	SHEET 22 of 28
---------------------------	----------	--------------	--	---	------------------	-------------------

9/10/2024 1:56:30 PM

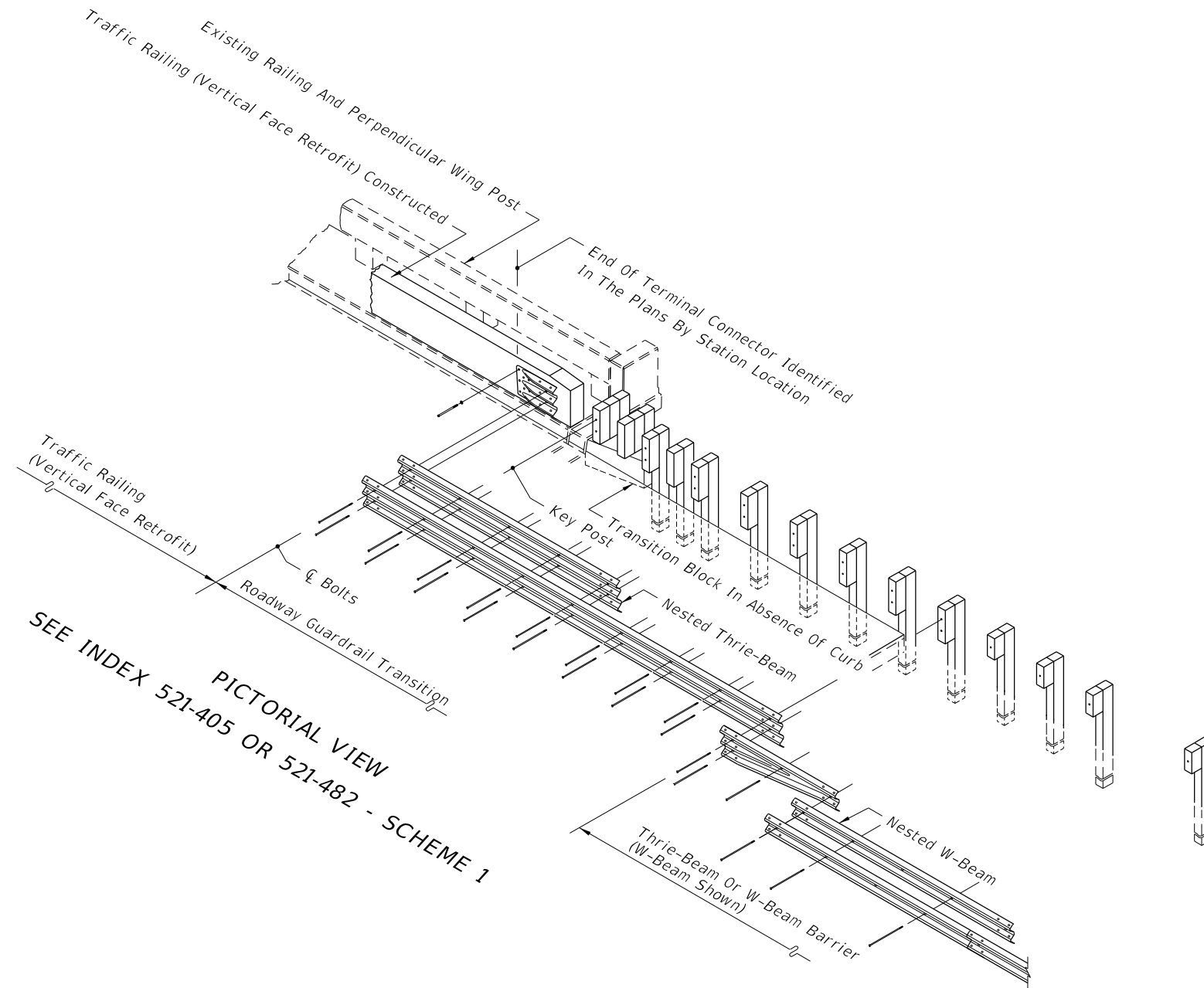

PICTORIAL VIEW
 SEE INDEX 521-405 OR 521-482 - SCHEME 1

PICTORIAL VIEWS OF GUARDRAIL APPROACH TRANSITIONS AND CONNECTIONS FOR BRIDGE TRAFFIC RAILING (VERTICAL FACE RETROFIT) (INDEX 521-482 SHOWN, INDEX 521-405 SIMILAR)

LAST REVISION 11/01/19	REVISION DESCRIPTION:	 FY 2025-26 STANDARD PLANS	GUARDRAIL TRANSITIONS AND CONNECTIONS FOR EXISTING BRIDGES	INDEX 536-002	SHEET 23 of 28
---------------------------	-----------------------	---	--	------------------	-------------------

9/10/2024 1:56:37 PM

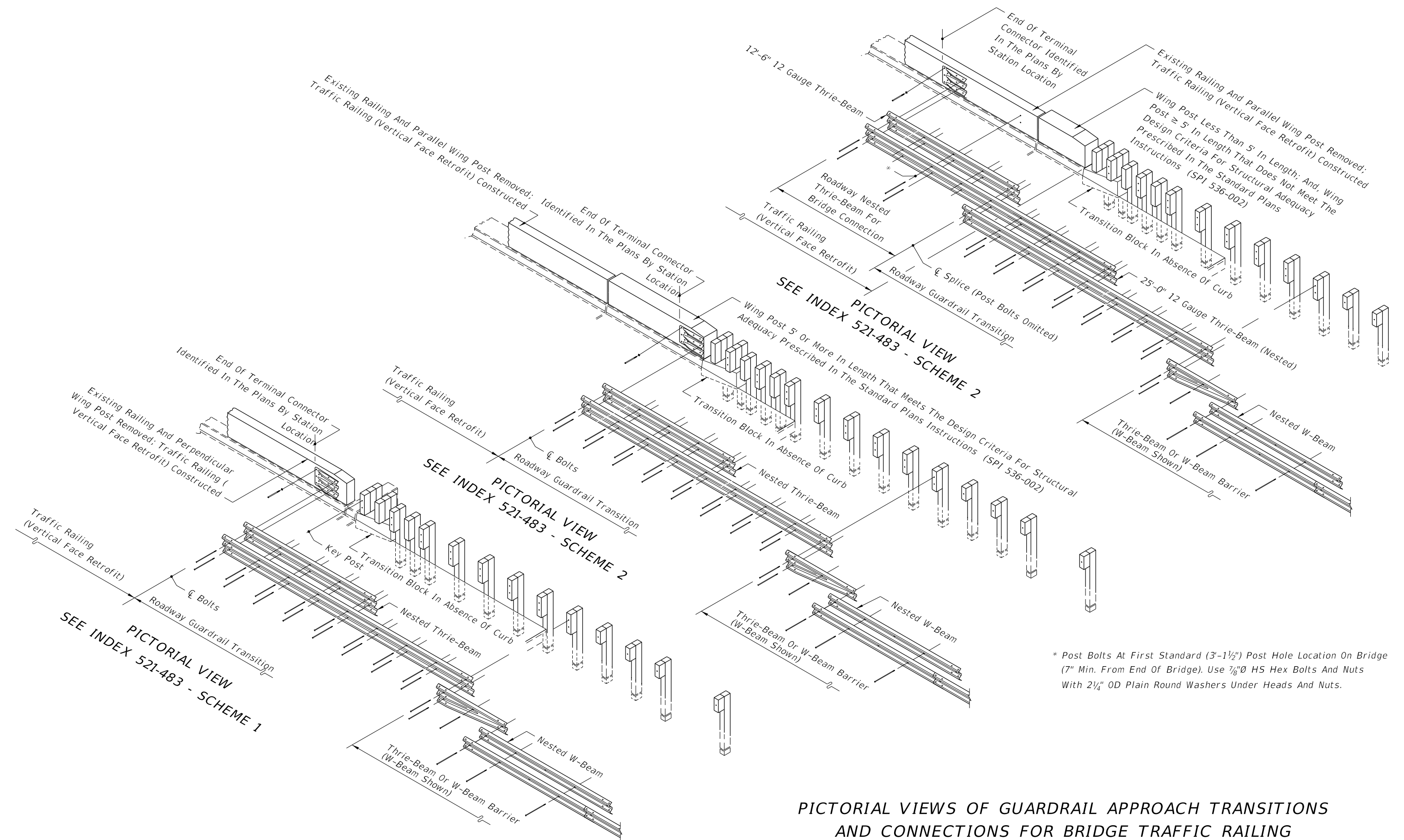

* Post Bolts At First Standard (3'-1 1/2") Post Hole Location On Bridge (7" Min. From End Of Bridge). Use 7/8" HS Hex Bolts And Nuts With 2 1/4" OD Plain Round Washers Under Heads And Nuts.

PICTORIAL VIEWS OF GUARDRAIL APPROACH TRANSITIONS AND CONNECTIONS FOR BRIDGE TRAFFIC RAILING (VERTICAL FACE RETROFIT)

LAST REVISION 11/01/19	REVISION DESCRIPTION:	 FY 2025-26 STANDARD PLANS	GUARDRAIL TRANSITIONS AND CONNECTIONS FOR EXISTING BRIDGES	INDEX 536-002	SHEET 24 of 28
---------------------------	--------------------------	---	--	------------------	-------------------

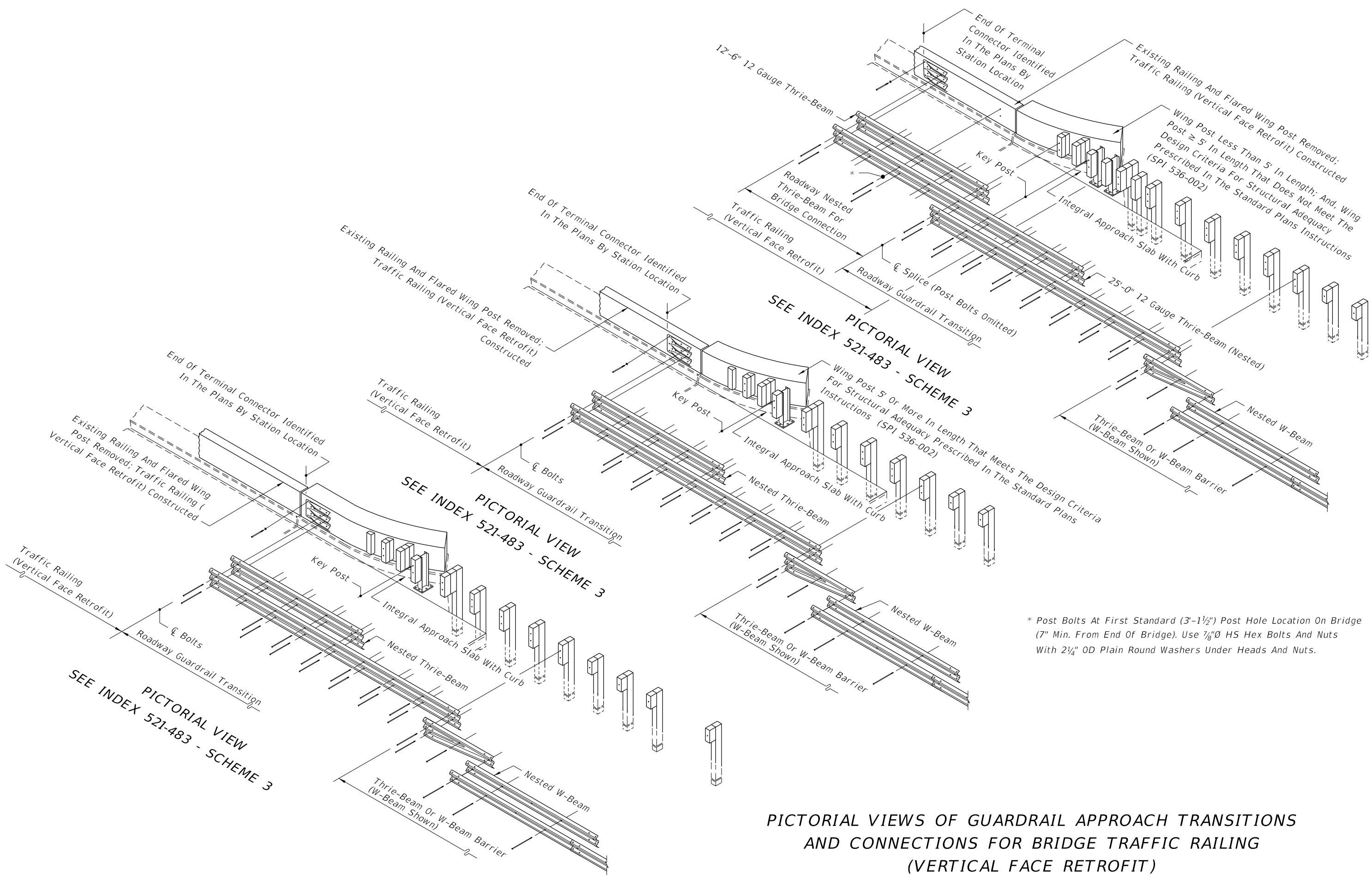

PICTORIAL VIEWS OF GUARDRAIL APPROACH TRANSITIONS AND CONNECTIONS FOR BRIDGE TRAFFIC RAILING (VERTICAL FACE RETROFIT)

9/10/2024 1:56:43 PM

LAST REVISION 11/01/19	REVISION	DESCRIPTION:	 FY 2025-26 STANDARD PLANS	GUARDRAIL TRANSITIONS AND CONNECTIONS FOR EXISTING BRIDGES	INDEX 536-002	SHEET 25 of 28
---------------------------	----------	--------------	--	---	------------------	-------------------

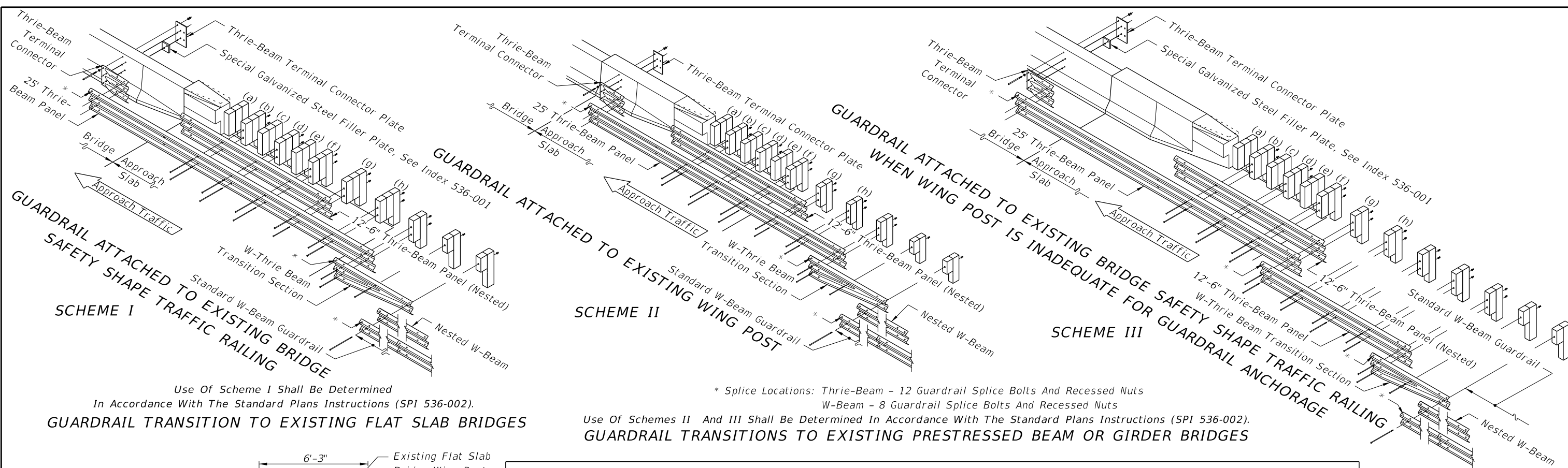

Use Of Scheme I Shall Be Determined In Accordance With The Standard Plans Instructions (SPI 536-002).
GUARDRAIL TRANSITION TO EXISTING FLAT SLAB BRIDGES

* Splice Locations: Thrie-Beam - 12 Guardrail Splice Bolts And Recessed Nuts
 W-Beam - 8 Guardrail Splice Bolts And Recessed Nuts
 Use Of Schemes II And III Shall Be Determined In Accordance With The Standard Plans Instructions (SPI 536-002).
GUARDRAIL TRANSITIONS TO EXISTING PRESTRESSED BEAM OR GIRDER BRIDGES

APPROACH POSTS AND SPECIAL OFFSET BLOCKS
 Block assemblies for special offsets can be made up of one special block plus one standard size block or of three standard size blocks field dressed to approximately equal size, with the pieces secured for relative position by 16d galvanized nails, see '16d NAIL FOR PREVENTION OF OFFSET BLOCK ROTATION' - Index 536-001. The nested rails shall not be bolted to the blocks and posts at posts (a), (c) and (e). The details shown are for approach slabs with internal edge dike extending beyond parapet type traffic railing termini.

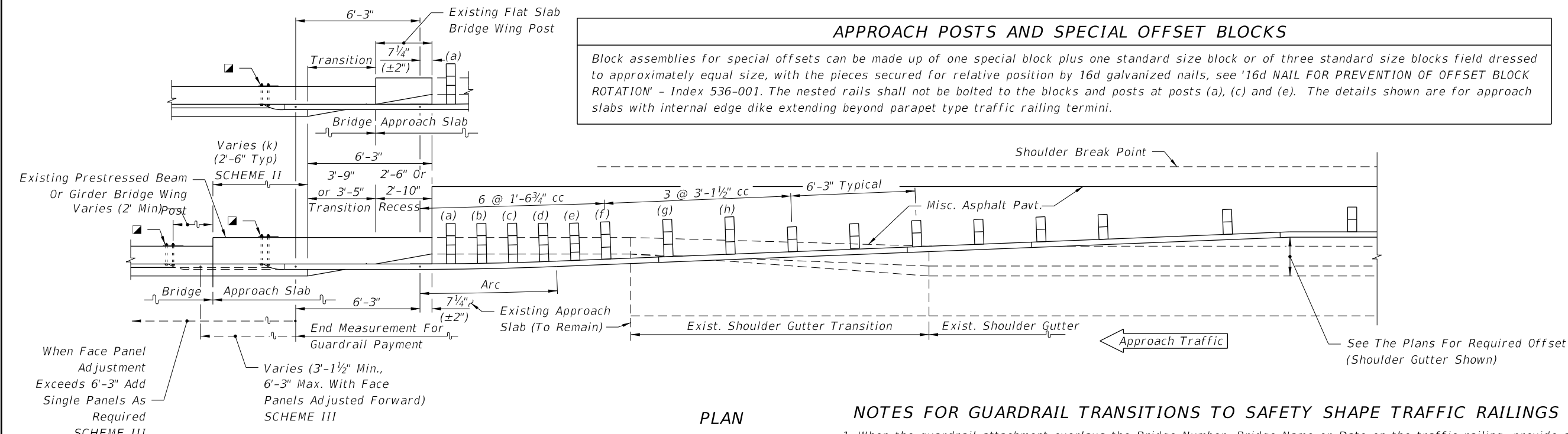

NOTES FOR GUARDRAIL TRANSITIONS TO SAFETY SHAPE TRAFFIC RAILINGS ON EXISTING BRIDGES

- When the guardrail attachment overlays the Bridge Number, Bridge Name or Date on the traffic railing, provide an aluminum sign panel with the obscured information. Attach the sign panel to the face of the traffic railing adjacent to the Thrie-Beam Terminal Connector with 1/4"Ø x 1" long concrete screws or expansion anchors at each corner, as approved by the Engineer. The sign panel shall be a minimum 1/16" thick and meet the requirements of Specification 700 with a white background and 3" tall black letters and sized appropriately to contain the information required. The cost of the sign panel shall be included in the cost of the Guardrail Bridge Anchorage Assembly.
- When retrofitting thrie-beam guardrail to existing wing posts or existing bridge safety shape traffic railing, attachment construction to be paid for under the contract unit price for Guardrail Bridge Anchorage Assembly, EA., and shall be full compensation for bolt hole construction, terminal connector, terminal connector plate(s) and bolts, nuts and washers.

GUARDRAIL APPROACH TRANSITION CONNECTIONS FOR EXISTING FLAT SLAB, PRESTRESSED BEAM AND GIRDER BRIDGES WITH SAFETY SHAPE TRAFFIC RAILING EXTENDING LESS THAN FULL APPROACH SLAB LENGTH

LAST REVISION 11/01/24	DESCRIPTION:		FY 2025-26 STANDARD PLANS	GUARDRAIL TRANSITIONS AND CONNECTIONS FOR EXISTING BRIDGES	INDEX	SHEET
			536-002		27 of 28	

9/10/2024 1:56:57 PM

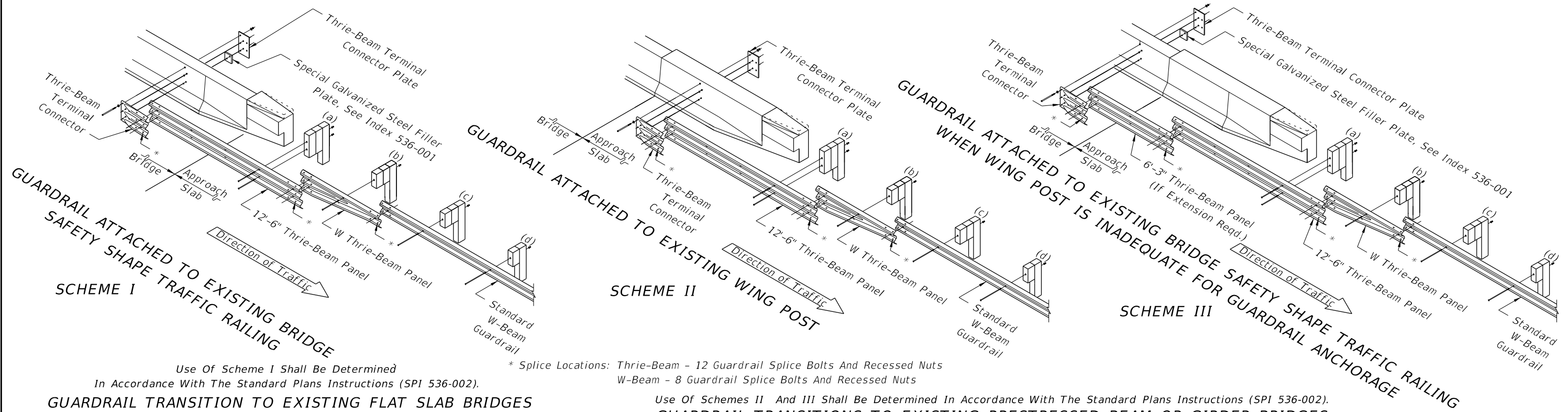

Use Of Scheme I Shall Be Determined In Accordance With The Standard Plans Instructions (SPI 536-002).
GUARDRAIL TRANSITION TO EXISTING FLAT SLAB BRIDGES

* Splice Locations: Thrie-Beam - 12 Guardrail Splice Bolts And Recessed Nuts
 W-Beam - 8 Guardrail Splice Bolts And Recessed Nuts
 Use Of Schemes II And III Shall Be Determined In Accordance With The Standard Plans Instructions (SPI 536-002).
GUARDRAIL TRANSITIONS TO EXISTING PRESTRESSED BEAM OR GIRDER BRIDGES

TRAILING END POSTS AND SPECIAL OFFSET BLOCKS
 Block assemblies for special offsets can be made up of one special block plus one standard size block or of three standard size blocks field dressed to approximately equal size, with the pieces secured for relative position by 16d galvanized nails, see '16d NAIL FOR PREVENTION OF OFFSET BLOCK ROTATION' - Index 536-001. The nested rails shall not be bolted to the blocks and posts at posts (a), (c) and (e). The details shown are for approach slabs with internal edge dike extending beyond parapet type traffic railing termini.

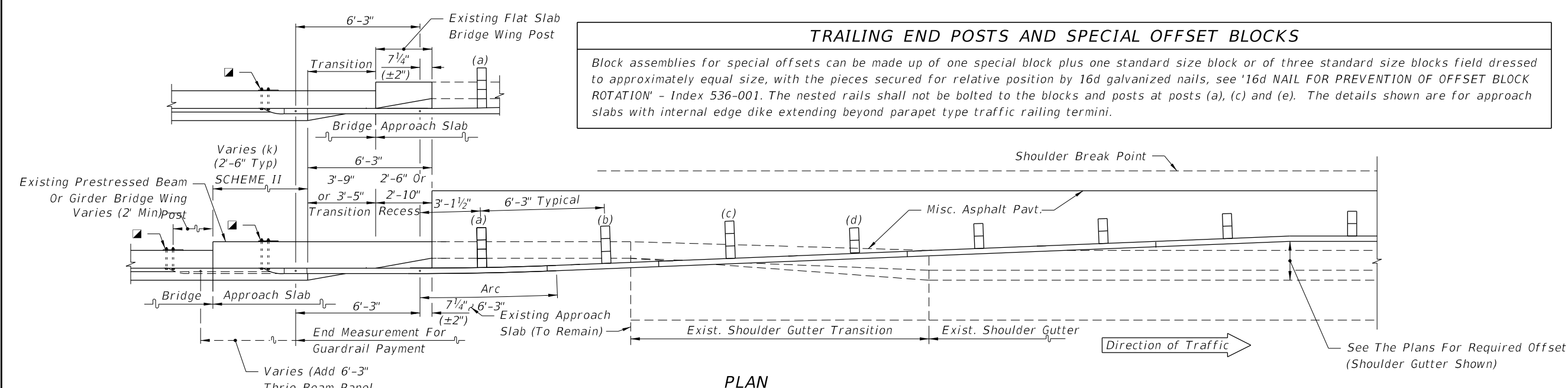

PLAN

NOTES FOR GUARDRAIL TRANSITIONS TO SAFETY SHAPE TRAFFIC RAILINGS ON EXISTING BRIDGES

1. When the guardrail attachment overlays the Bridge Number, Bridge Name or Date on the traffic railing, provide an aluminum sign panel with the obscured information. Attach the sign panel to the face of the traffic railing adjacent to the Thrie-Beam Terminal Connector with 1/4"Ø x 1" long concrete screws or expansion anchors at each corner, as approved by the Engineer. The sign panel shall be a minimum 1/16" thick and meet the requirements of Specification 700 with a white background and 3" tall black letters and sized appropriately to contain the information required. The cost of the sign panel shall be included in the cost of the Guardrail Bridge Anchorage Assembly.
2. When retrofitting thrie-beam guardrail to existing wing posts or existing bridge safety shape traffic railing, attachment construction to be paid for under the contract unit price for Guardrail Bridge Anchorage Assembly, EA., and shall be full compensation for bolt hole construction, terminal connector, terminal connector plate(s) and bolts, nuts and washers.

GUARDRAIL TRAILING END TRANSITION CONNECTIONS FOR EXISTING FLAT SLAB, PRESTRESSED BEAM AND GIRDER BRIDGES WITH SAFETY SHAPE TRAFFIC RAILING EXTENDING LESS THAN FULL APPROACH SLAB LENGTH

LAST REVISION 11/01/24	DESCRIPTION: 	FY 2025-26 STANDARD PLANS	GUARDRAIL TRANSITIONS AND CONNECTIONS FOR EXISTING BRIDGES	INDEX 536-002	SHEET 28 of 28
---------------------------	--	------------------------------	---	------------------	-------------------

9/10/2024 1:57:04 PM