

**SIGNAL PLACEMENT AT RAILROAD CROSSING
(2 - LANE DESIGN)**

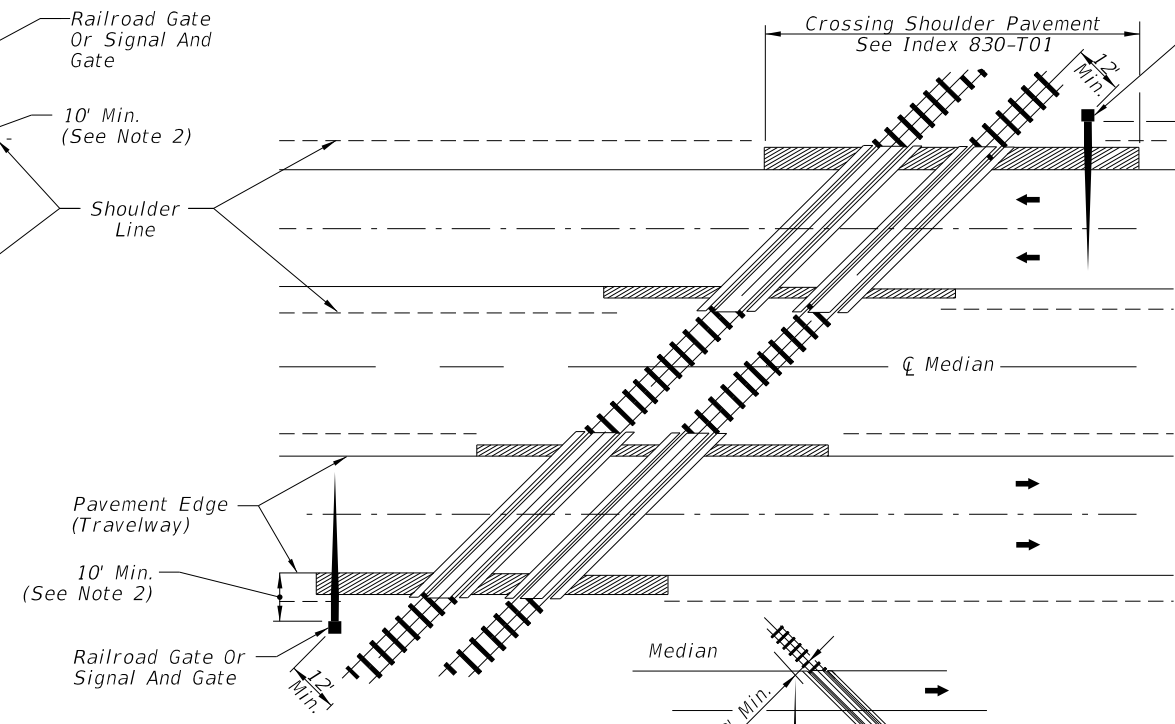

**SIGNAL PLACEMENT AT RAILROAD CROSSING
(4 - LANE DESIGN)**

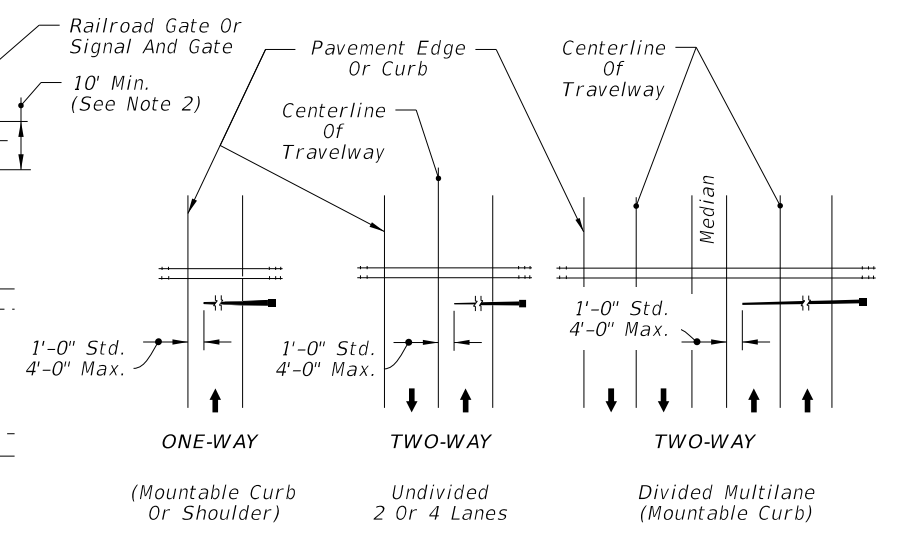

FIGURE 1

NOTE: Arrows denote direction of travel not pavement markings.

GENERAL NOTES:

- No guardrail is proposed for signals; however, some form of impact attenuation device may be specified for certain locations.
- Advance flasher to be installed when and if called for in Plans or Specifications.
- Top of foundation shall be no higher than 4" above finished shoulder grade.
- Type of traffic control device
 - Flashing warning devices
 - Flashing warning devices with cantilever
 - Flashing warning devices with gate
 - Flashing warning devices with cantilever and gate
 - Gate
- Class of traffic control devices (Not Shown)
 - 2 Quadrant flashing warning devices-one track
 - 2 Quadrant flashing warning devices-multiple tracks
 - 2 Quadrant flashing warning devices and gates-one track
 - 2 Quadrant flashing warning devices and gates-multiple tracks
 - 3-4 Quadrant flashing warning devices and gates-one track
 - 3-4 Quadrant flashing warning devices and gates-multiple tracks

NOTE:

- Two separate foundations may be required (one for signals, one for gate), depending on type of equipment used.
- When 10' is deemed impractical the control device can be located as close as 2' from the edge of a paved shoulder but not less than 6' from the edge of the near traffic lane.

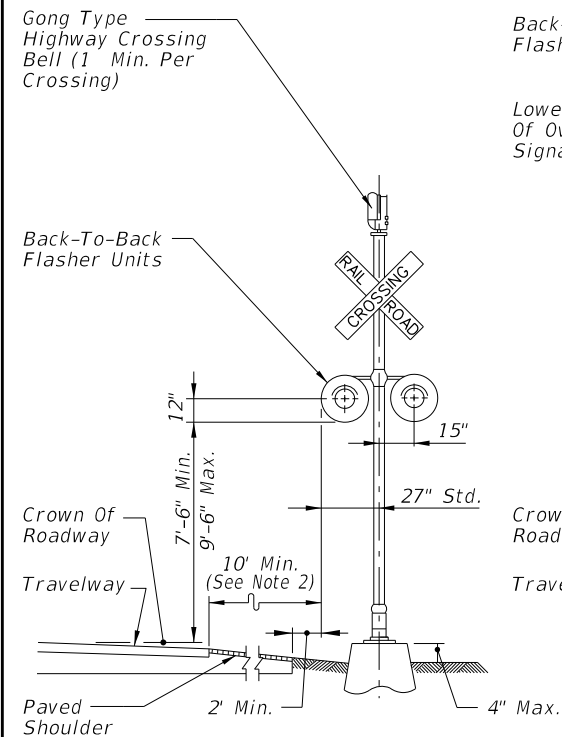

TYPE I

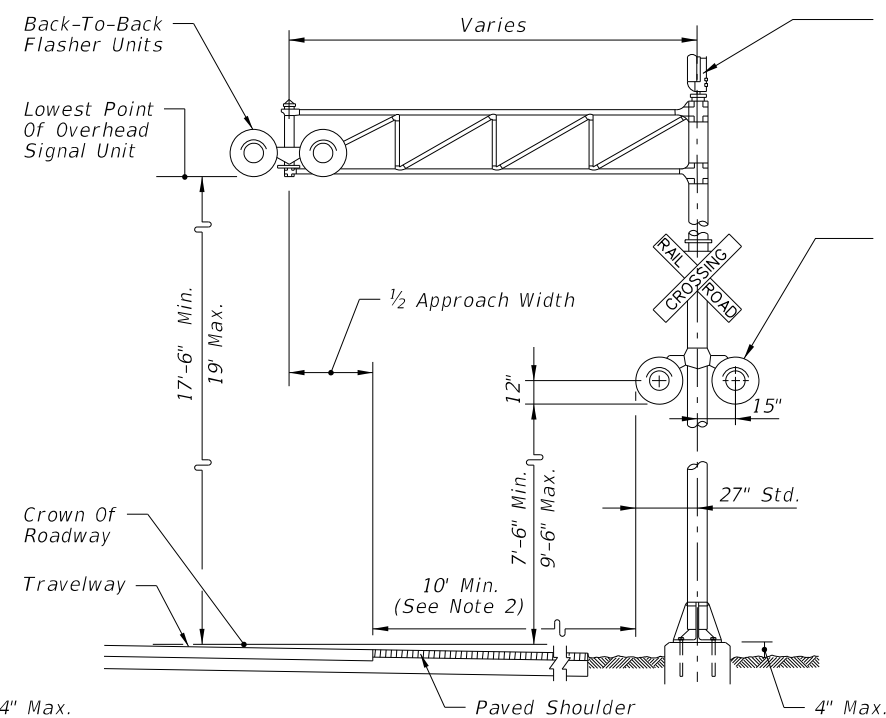

TYPE II

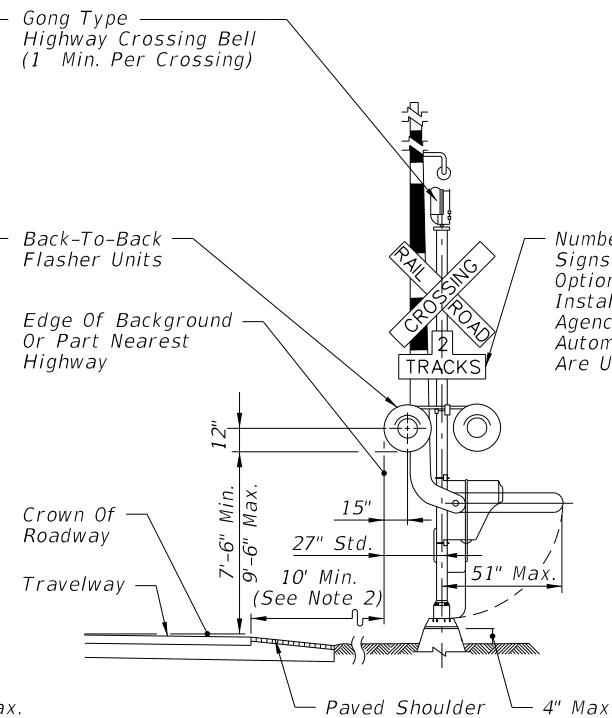

TYPE III

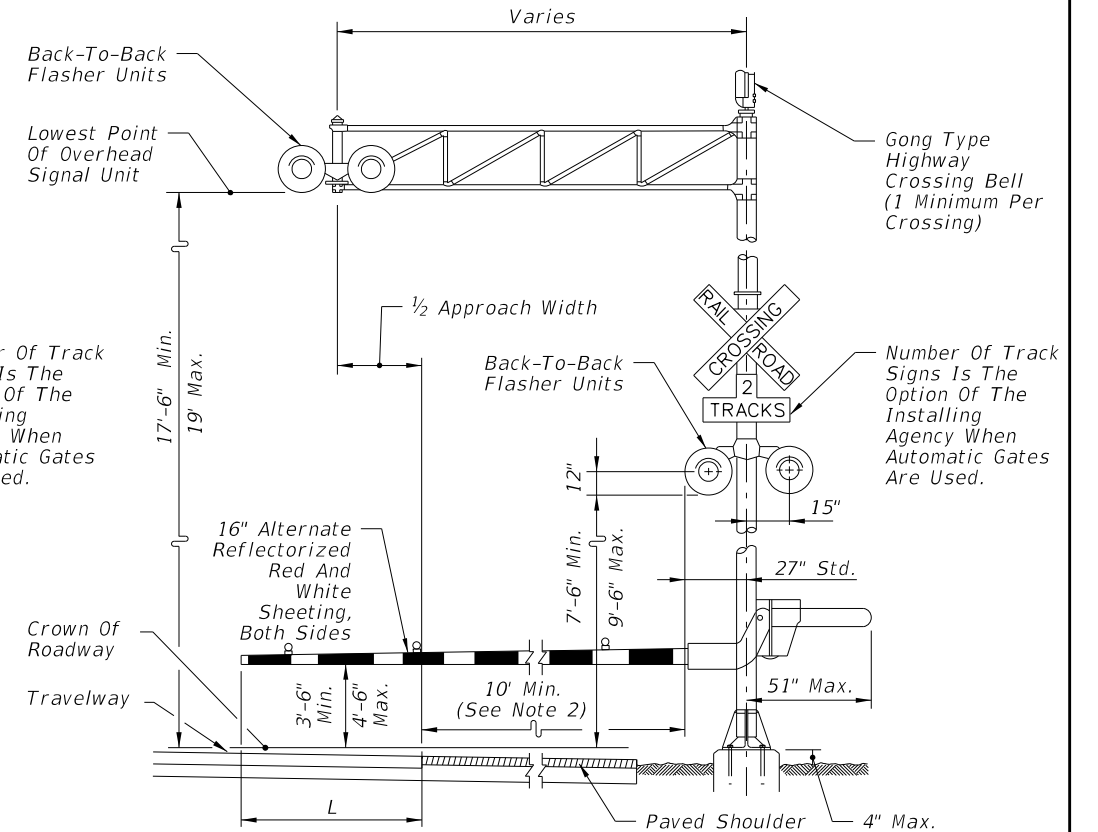

TYPE IV

TRAFFIC CONTROL DEVICES FOR FLUSH SHOULDER ROADWAY

9/10/2024 1:11:12 PM

LAST REVISION 11/01/23	REVISION	DESCRIPTION:		FY 2025-26 STANDARD PLANS	RAILROAD GRADE CROSSING TRAFFIC CONTROL DEVICES	INDEX 509-070	SHEET 1 of 3
---------------------------	----------	--------------	--	------------------------------	--	------------------	-----------------

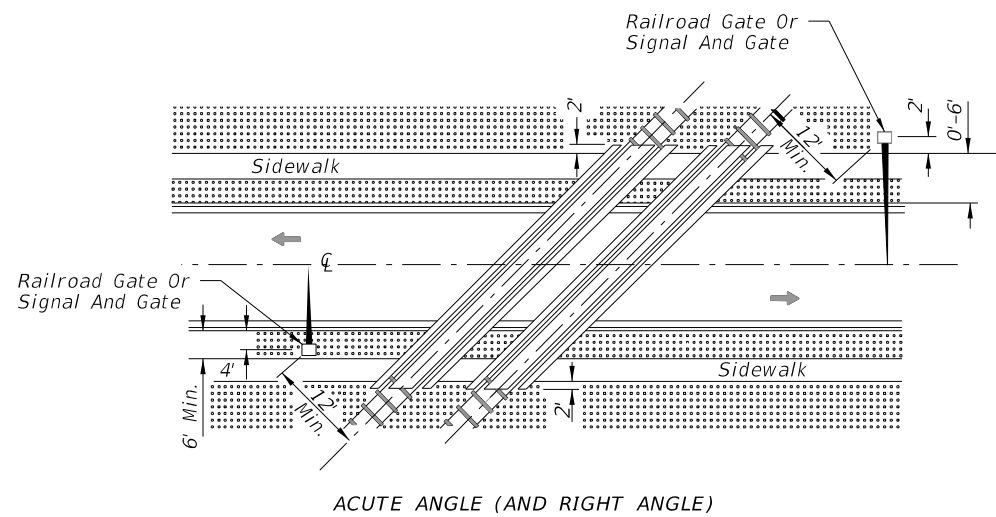

ACUTE ANGLE (AND RIGHT ANGLE)

SIGNAL PLACEMENT AT RAILROAD CROSSING

(2 LANES, CURB & GUTTER)

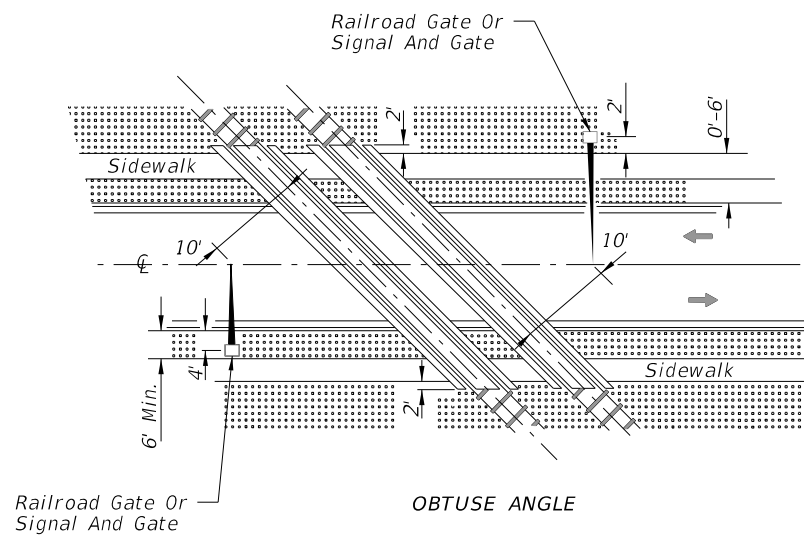

OBTUSE ANGLE

SIGNAL PLACEMENT AT RAILROAD CROSSING

(2 LANES, CURB & GUTTER)

NOTES:

1. The location of flashing warning devices and stop lines shall be established based on future (or present) installation of gate with appropriate track clearances.
2. Where plans call for railroad traffic control devices to be installed in curbed medians, the minimum median width shall be 12'-6".
3. Location of railroad traffic control device is based on the distance available between face of curb & sidewalk. 0' to 6' - Locate device outside sidewalk. Over 6' - Locate device between face of curb and sidewalk.
4. Stop line to be perpendicular to edge of roadway, approx. 15' from nearest rail; or 8' from and parallel to gate when present.
5. When a cantilevered-arm flashing warning device is used, the minimum vertical clearance shall be 17'-6" from above the Crown of Roadway to the Lowest Point of the Overhead Signal Unit.

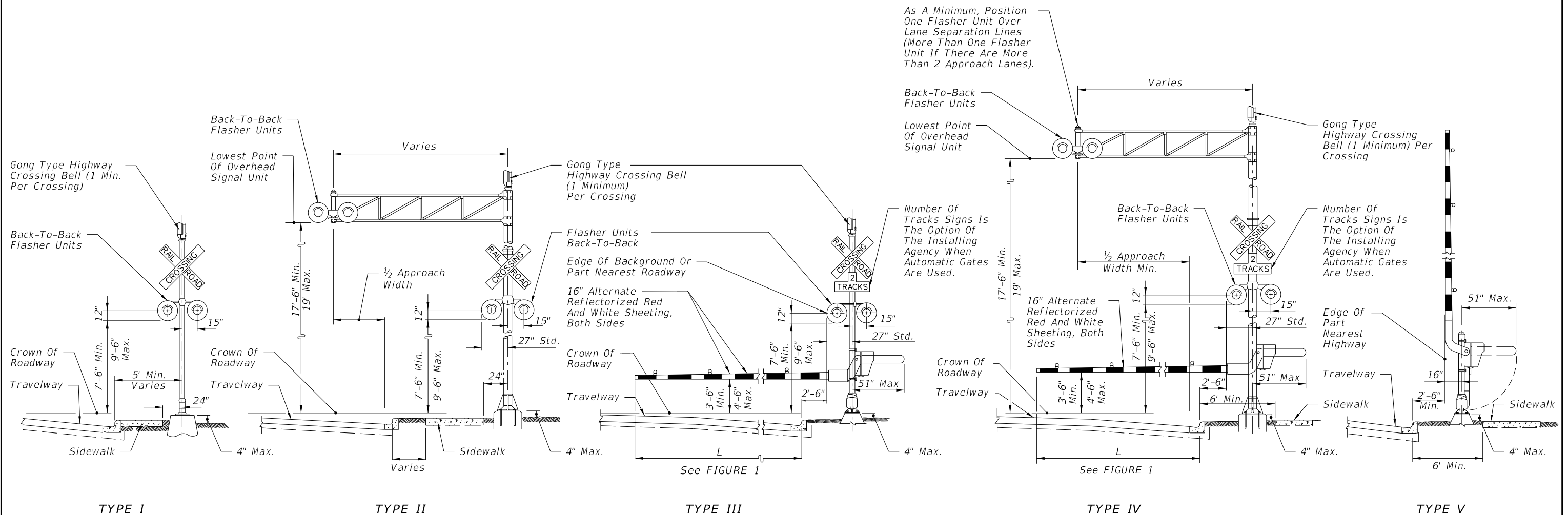

TYPE I

TYPE II

TYPE III

TYPE IV

TYPE V

TRAFFIC CONTROL DEVICES FOR CURBED ROADWAY

9/10/2024 1:11:19 PM

LAST REVISION 11/01/23	DESCRIPTION:		FY 2025-26 STANDARD PLANS	RAILROAD GRADE CROSSING TRAFFIC CONTROL DEVICES	INDEX 509-070	SHEET 2 of 3

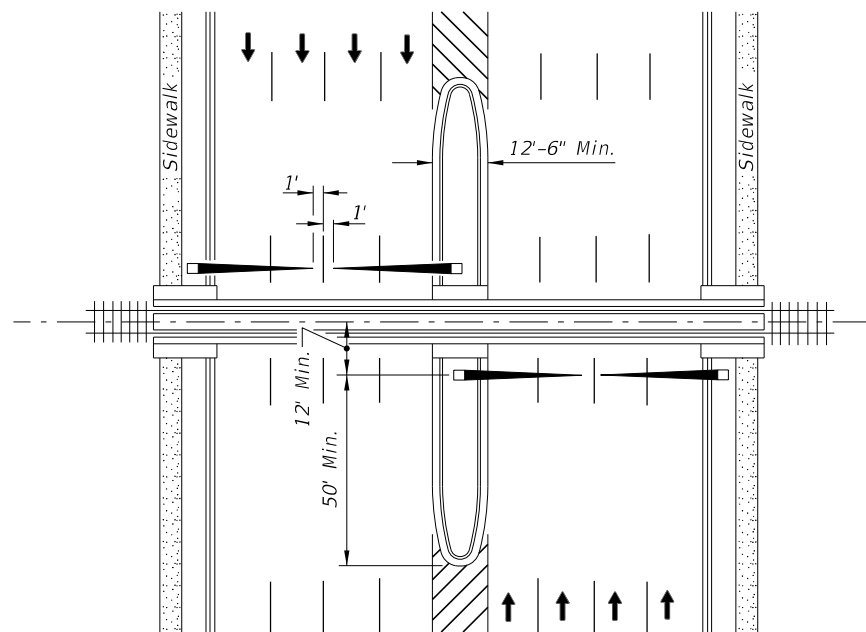

PLAN

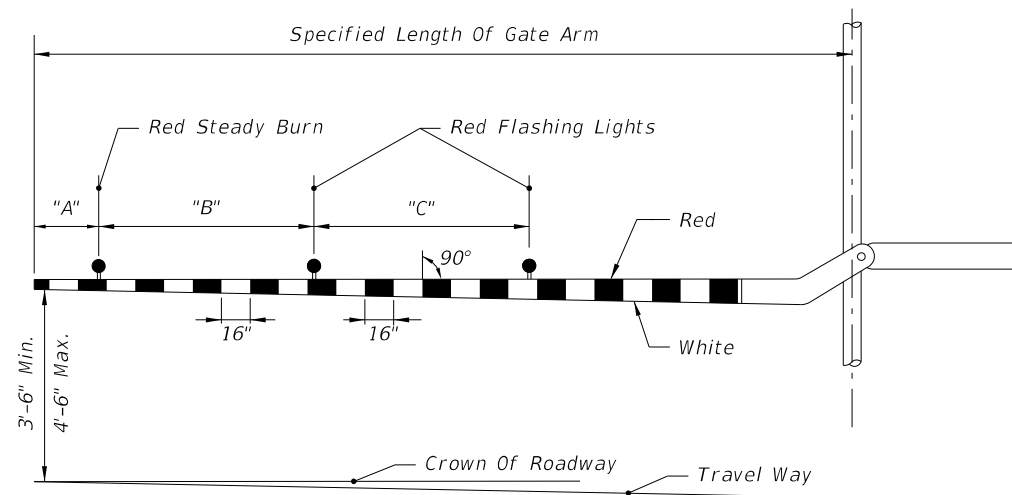

GATE ARM DETAIL

RAILROAD GATE ARM LIGHT SPACING			
Specified Length Of Gate Arm	Dimension "A"	Dimension "B"	Dimension "C"
14 Ft.	6"	36"	5'
15 Ft.	18"	36"	5'
16-17 Ft.	24"	36"	5'
18-19 Ft.	28"	41"	5'
20-23 Ft.	28"	4'	5'
24-28 Ft.	28"	5'	5'
29-31 Ft.	36"	6'	6'
32-34 Ft.	36"	7'	7'
35-37 Ft.	36"	9'	9'
38 And Over	36"	10'	10'

NOTE:

For additional information see the "Manual On Uniform Traffic Control Devices", Part 8; The "Traffic Control Handbook", Part VIII; and AASHTO "A Policy On Geometric Design Of Streets And Highways".

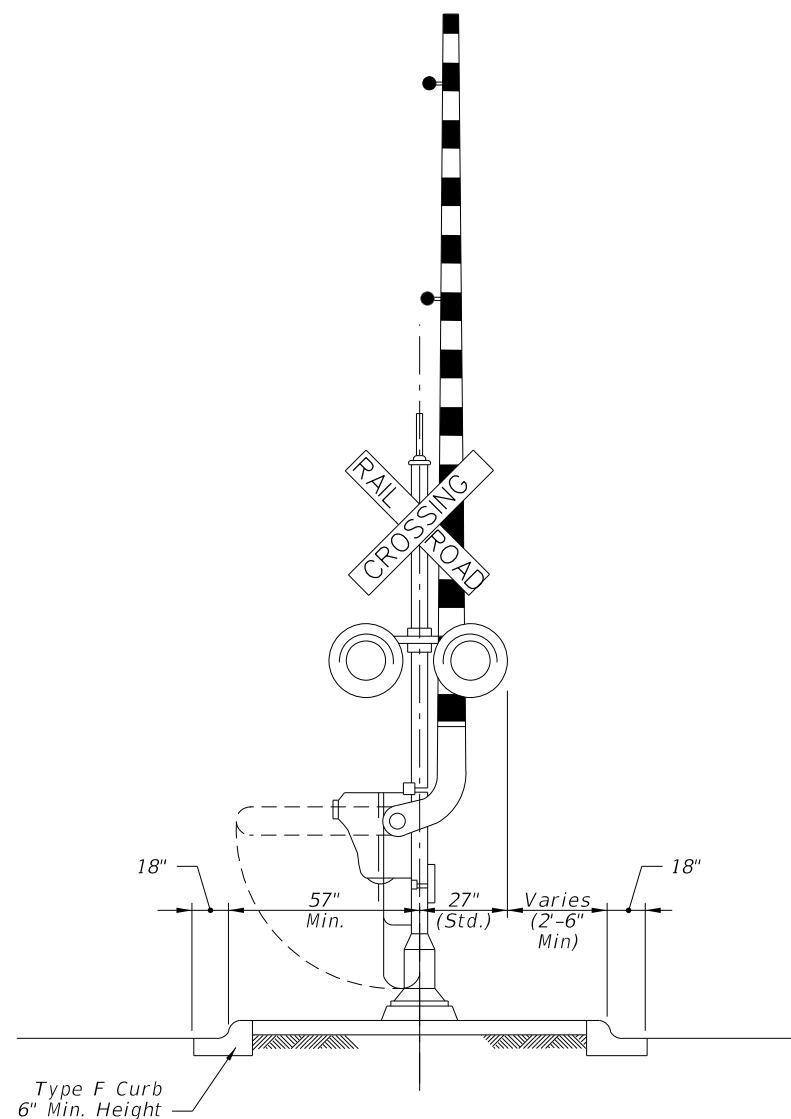

MEDIAN SECTION AT SIGNAL GATES

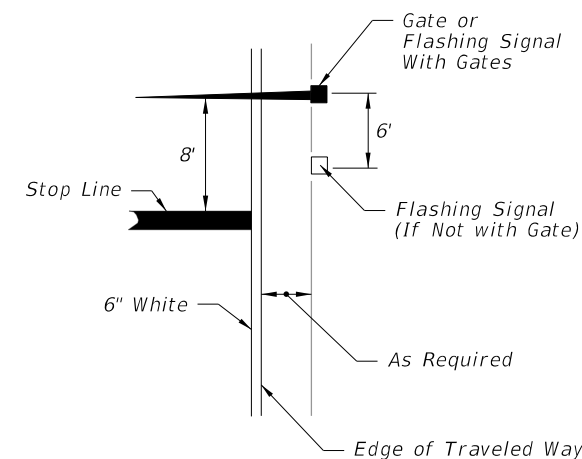

RELATIVE LOCATION OF CROSSING TRAFFIC CONTROL DEVICES

MEDIAN SIGNAL GATES FOR MULTILANE UNDIVIDED URBAN SECTIONS
(Three or More Driving Lanes in one Direction, 45 mph or less)

9/10/2024 1:11:26 PM