

PLAN VIEW OF ACCESS HATCH ASSEMBLY

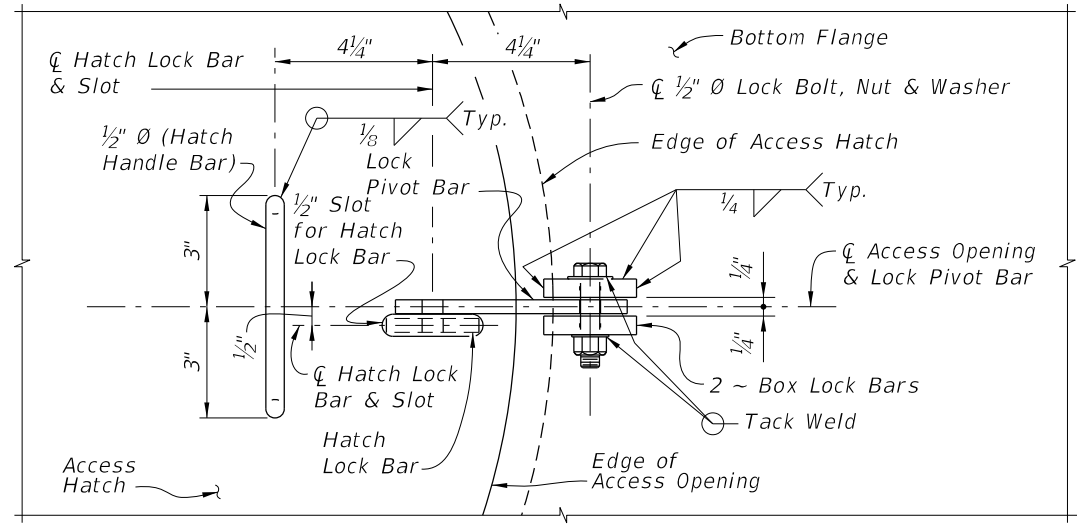

VIEW A-A

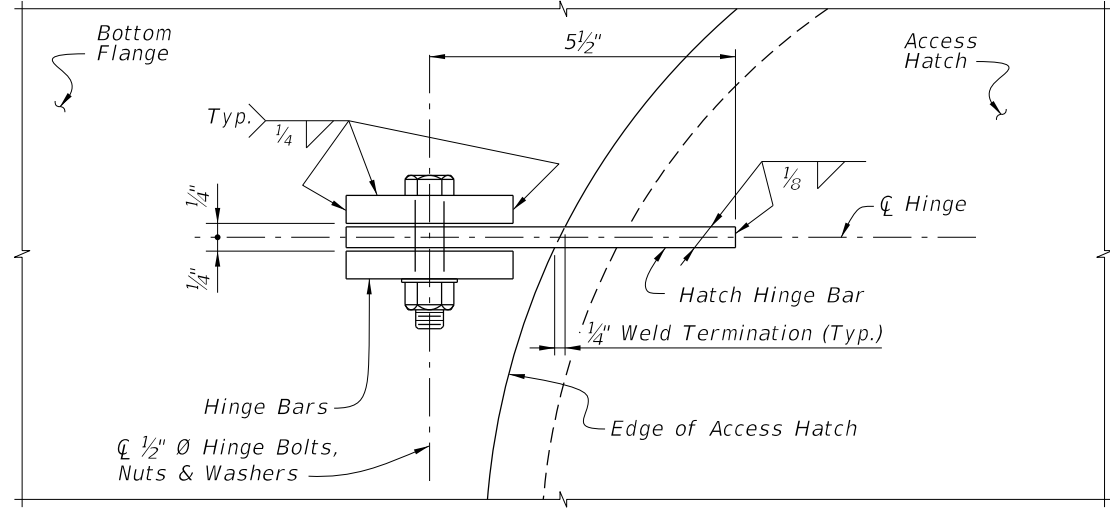

HINGE DETAIL

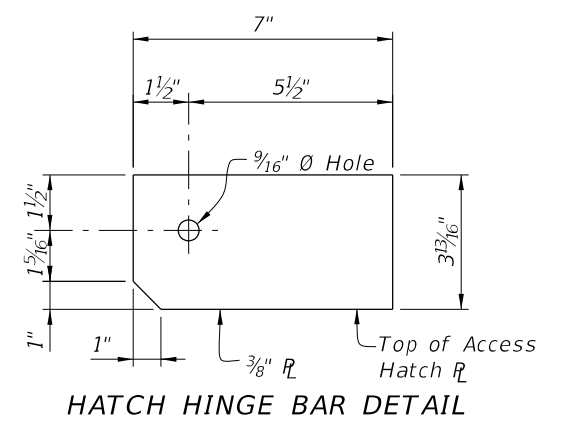

HATCH HINGE BAR DETAIL

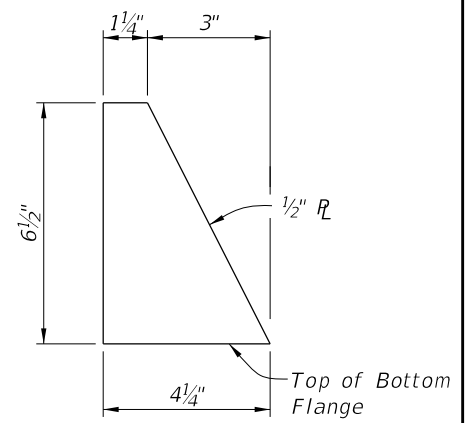

STOP BAR DETAIL

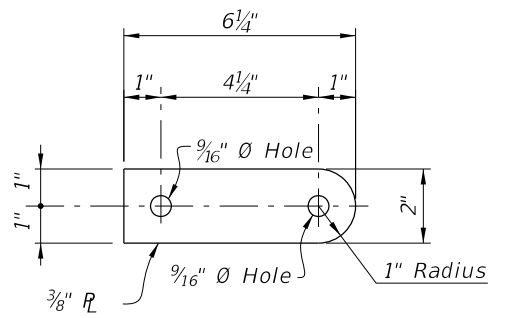

LOCK PIVOT BAR DETAIL

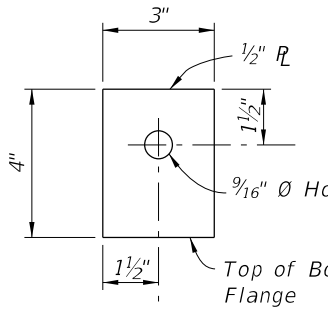

HINGE BAR DETAIL

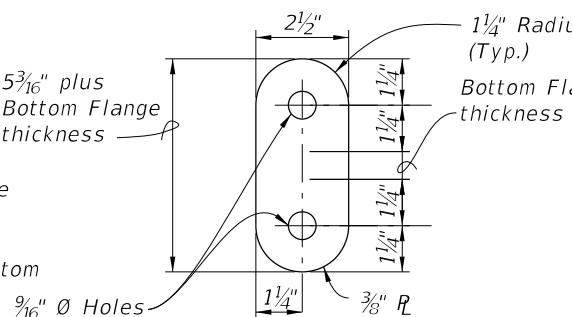

HATCH LOCK BAR DETAIL

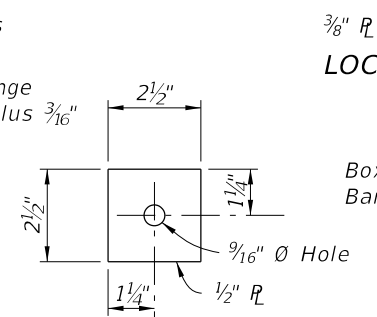

BOX LOCK BAR DETAIL

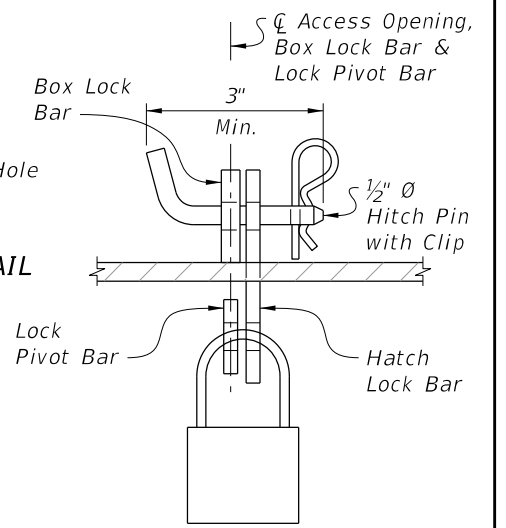

VIEW B-B HATCH LOCK ASSEMBLY DETAIL

HINGE NOTE:  
Orient the Access Hatch so that the hinges are located down-grade.

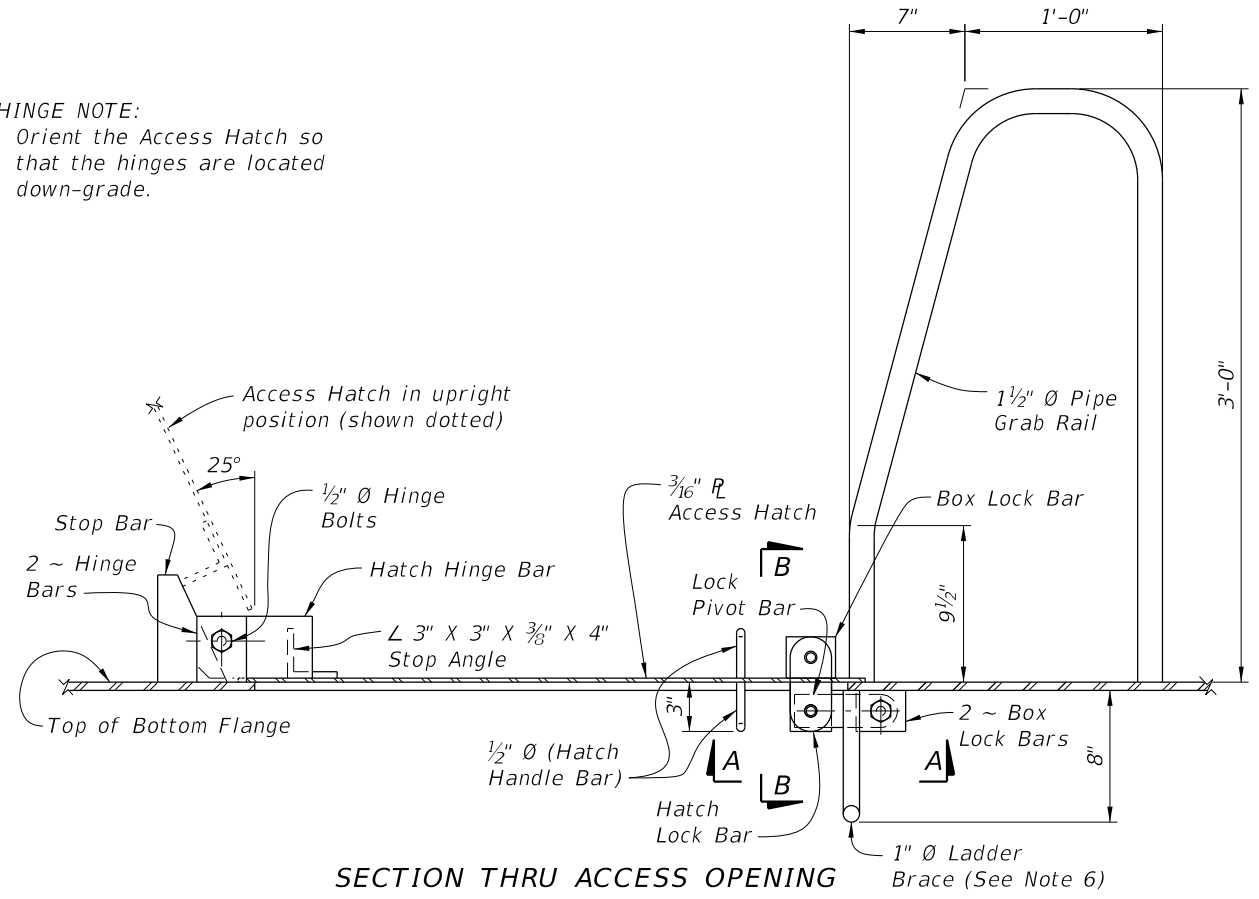

SECTION THRU ACCESS OPENING

- NOTES:
- All Structural Steel material in Access Hatch Assemblies shall conform to ASTM A709 Grade 36.
  - 1 1/2" Ø Pipe Grab Rail shall be in accordance with ASTM A53 Grade B for standard weight pipe (Schedule 40).
  - 1/2" Ø Hatch Handle Bar, Hitch Pin and 1" Ø Ladder Brace shall be in accordance with ASTM A36.
  - All bolts shall conform to ASTM A307 or A449. All nuts shall conform to ASTM A563 and all washers shall conform to ASTM F-436.
  - All exposed edges of plates and openings shall be ground smooth.
  - Place Ladder Brace near the End Bents exclusively and only when the height is reasonable for access by a Ladder.
  - See Framing Plan sheets for locations of Access Hatch Openings.
  - Coat structural steel in accordance with Specification Section 560.
  - Include the cost of the Access Hatch Assembly and incidental items in the cost of the Steel Box Girders. No separate payment will be made for coating structural steel.

10/17/2024 10:11:27 AM

LAST REVISION 07/01/15	DESCRIPTION:		FY 2025-26 STANDARD PLANS	ACCESS HATCH ASSEMBLY FOR STEEL BOX SECTIONS	INDEX 460-250	SHEET 1 of 1
REVISION						