

GENERAL NOTES:

1. Work with Index 425-001 and Index 425-010.
2. Use Class II Concrete.
3. Maximum opening for pipe shall be the pipe OD plus 6". Mortar used to seal the pipe into the opening will be of such mix that shrinkage will not cause leakage into or out of the structure.
4. If a conflict with a potable water supply line is discovered during construction, submit the following to Florida Department of Environmental Protection (FDEP) District Administrator For Drinking Water prior to constructing conflict structure:
 - a. Plans Revision(s)
 - b. Justification describing inordinate cost and practical avoidance
 - c. Upon request, Utility Agency Owner (UAO) supporting documentation for cost of relocation or adjustment

Potable water supply lines passing through a drainage structure must be in compliance with Chapter 62-555.314(3) F.A.C. This Index and rule citation provide accepted methods for addressing conflicts when they cannot be reasonably avoided.

Website for District FDEP Drinking Water Contacts:
<https://floridadep.gov/water/source-drinking-water/content/organization-drinking-water-program>

TABLE OF CONTENTS:	
Sheet	Description
1	General Notes and Contents
2	Utility Conflict Condition I and II Details

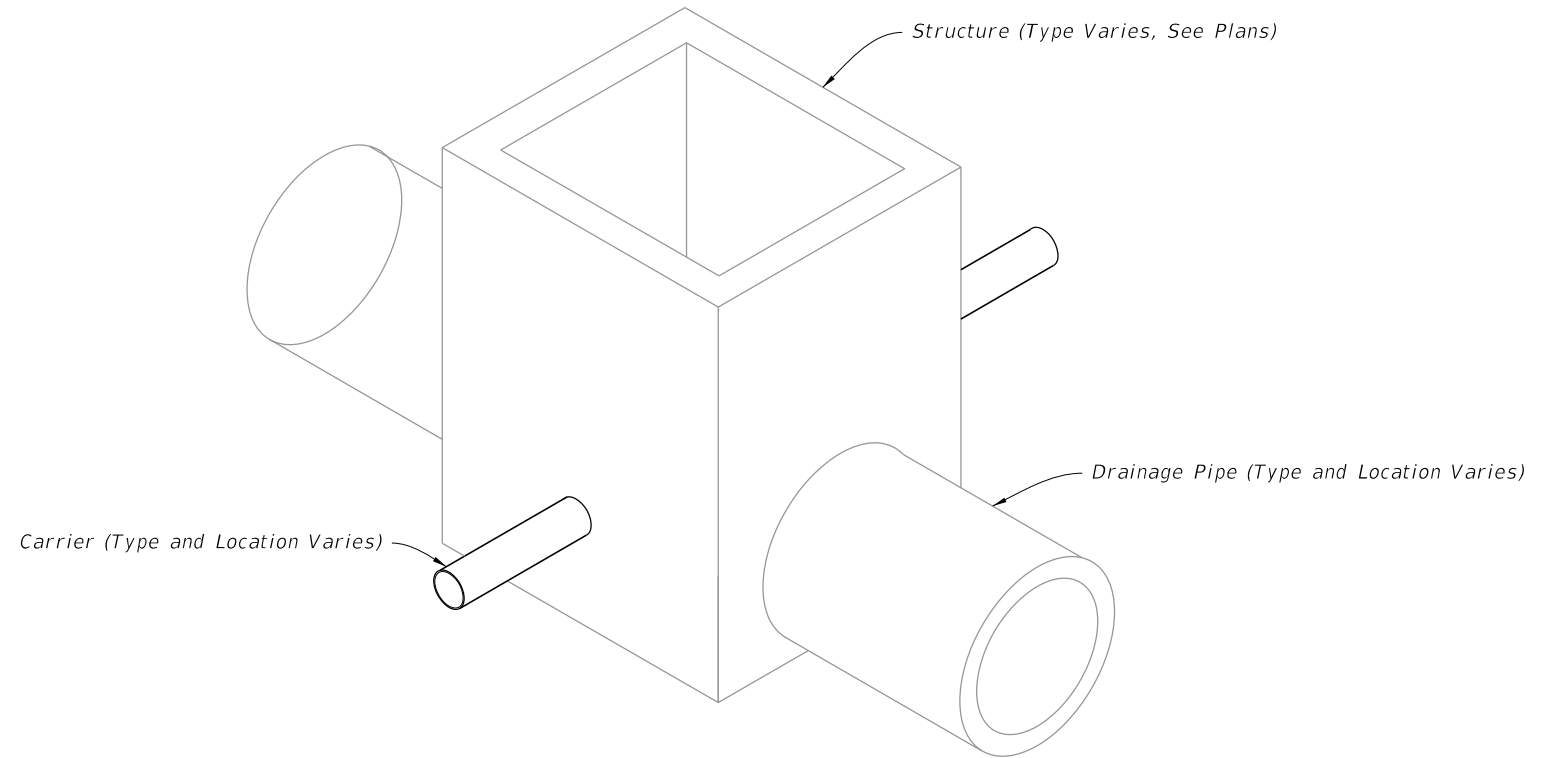

UTILITY CONFLICT
 (Condition I Shown, Condition II Similar)

9/10/2024 11:52:04 AM

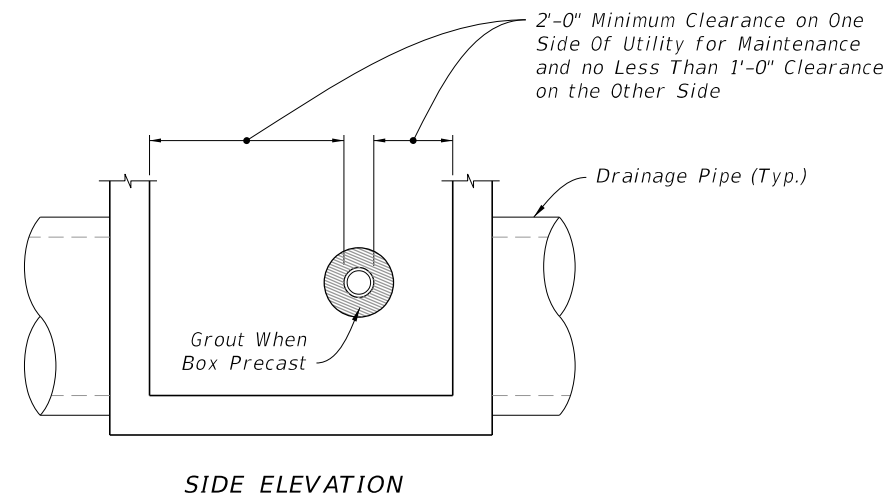
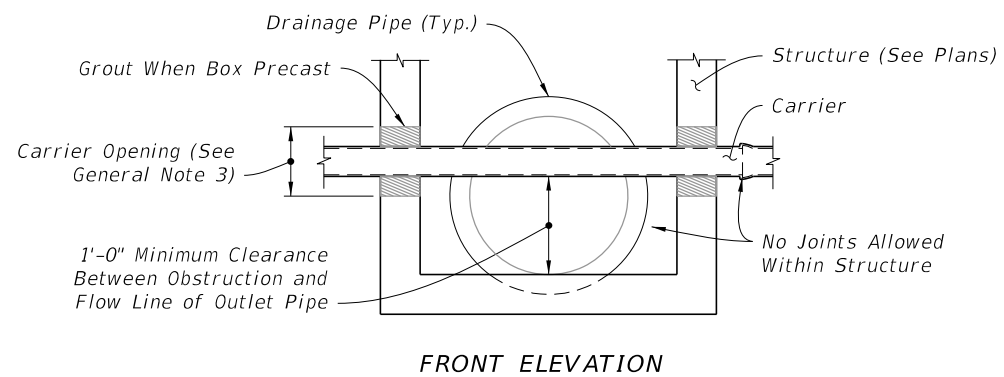
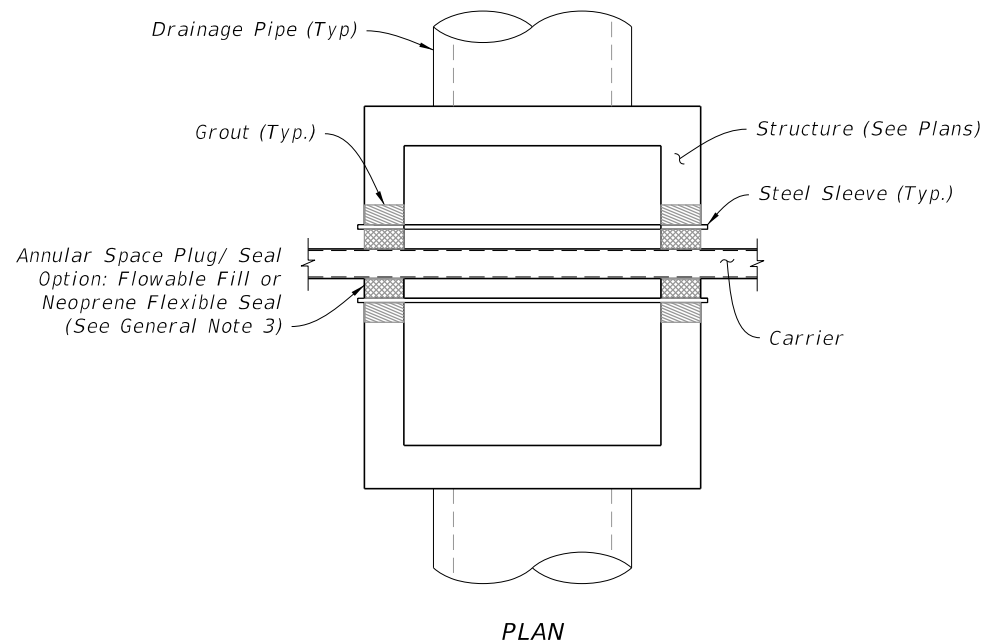
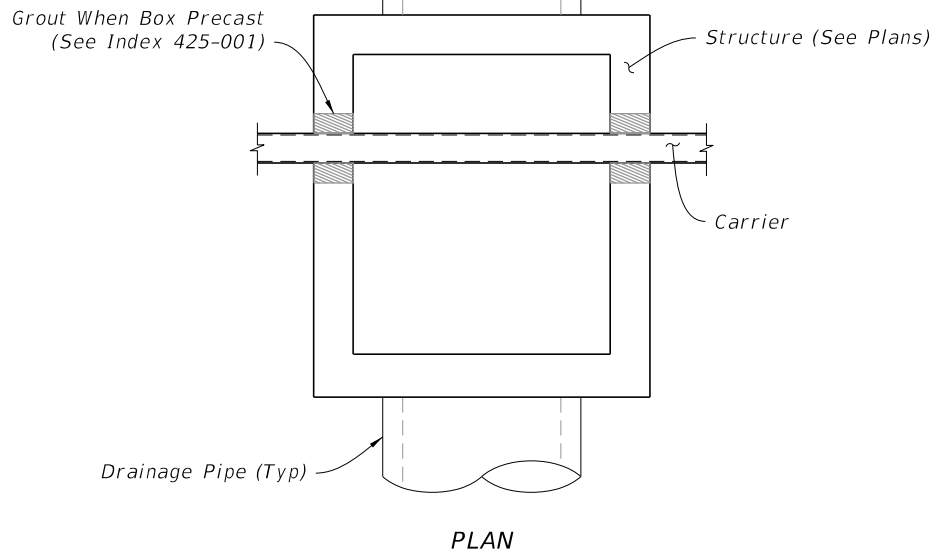

UTILITY CONFLICT CONDITION I
(Nonpressure or Nonfluid Carrier Installations)

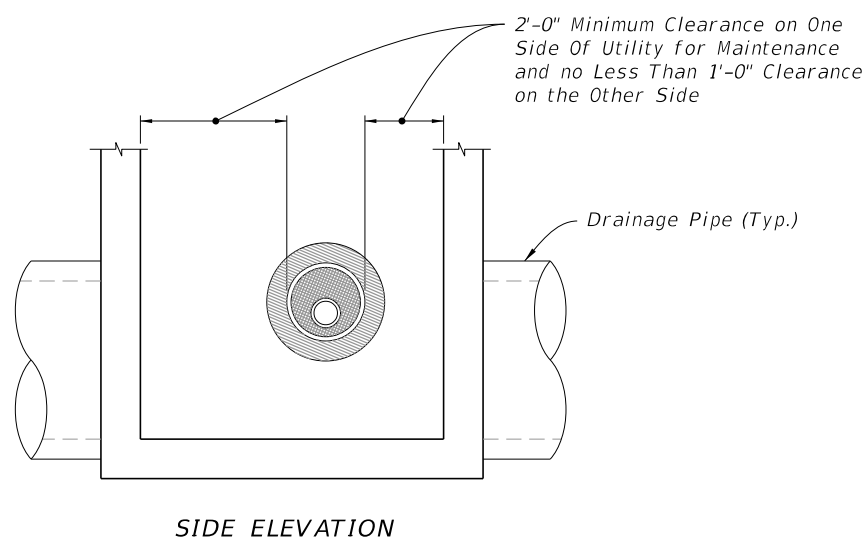
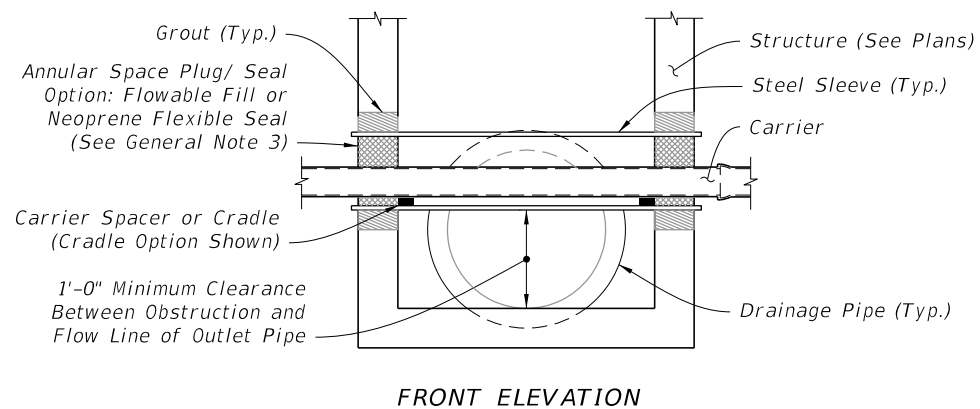

UTILITY CONFLICT CONDITION II
(Pressure or Fluid Carrier Installations)

UTILITY CONFLICT CONDITION I AND II DETAILS

9/10/2024 11:52:12 AM

LAST REVISION 11/01/20	DESCRIPTION:
---------------------------	--------------



FY 2025-26
STANDARD PLANS

UTILITY CONFLICT THRU DRAINAGE STRUCTURES

INDEX
425-080

SHEET
2 of 2