

Index 450-010 Series Prestressed Florida-I Beams

Design Criteria

AASHTO LRFD Bridge Design Specifications; Structures Detailing Manual (SDM); Structures Design Guidelines (SDG)

Design Assumptions and Limitations

Index 450-010 is the lead standard for the Prestressed Florida-I Beam standard series which includes Indexes 450-010 through 450-096. Use this standard with Indexes 450-036, 450-045, 450-054, 450-063, 450-072, 450-078, 450-084, 450-096, 450-199, 400-510, and 450-511 or 450-512.

These Indexes must be supplemented with project specific information including a Table of Beam Variables, Strand Pattern Details and a Strand Debonding Legend which must be completed and included in the Structures Plans. These Indexes and the supplemental project specific information that is included in the plans provide sufficient information to permit beam fabrication without the submittal of shop drawings.

Data tables for associated Indexes 450-199, 400-510, and 450-511 or 450-512 must also be completed and included in the plans.

The use of End Diaphragms is not preferred on simple span, pretensioned, Florida-I Beam structures. In lieu of End Diaphragms, the preferred detail is a Thickened Slab End at all locations of slab discontinuity. Where End Diaphragms are required by design or for widening projects, partial depth diaphragms are preferred. See **SDM** Chapter 15 for suggested details.

Except for widening projects where special details may be required, squared beam ends are preferred on all Florida-I Beam structures.

The prestressed beams in these Standard Drawings are generally assumed to act as simple spans under both Dead Load and Live Load even where the deck is detailed to be continuous across the intermediate supports or back-to-back diaphragms are present. For detailing purposes, Prestressed Florida-I Beams are assumed to be erected plumb.

When the total initial tensioning force of the fully bonded strands required by design exceeds the values shown below, shield additional strands at the end of the beam when possible. The end reinforcement may only be redesigned to accommodate an increased vertical splitting force when approved by the State Structures Design Office. If approval is granted, Index 450-010 and the appropriate Standard Detail Drawings must then be modified for inclusion in the contract documents and signed and sealed by the EOR.

To limit vertical splitting forces in the webs of beams, the maximum prestress force at the beam ends from fully bonded strands must be limited to the following:

Index No.	Beam Type	Max. Bonded Prestress Force	Last Revision Date
450-036	Florida-I 36	1450 Kips	07/01/09
450-045	Florida-I 45	1670 Kips	07/01/09
450-054	Florida-I 54	1740 Kips	07/01/09
450-063	Florida-I 63	1740 Kips	07/01/09
450-072	Florida-I 72	1980 Kips	07/01/09
450-078	Florida-I 78	2230 Kips	07/01/09
450-084	Florida-I 84	2375 Kips	07/01/10
450-096	Florida-I 96	2375 Kips	07/01/10

Do not apply losses and use the jacking force of all the strands located in the bottom half of the beam when calculating the Bonded Prestress Force.

Embedded Bearing Plates are required for all beams. If the beam grade exceeds 2%, provide Beveled Bearing Plates at each end of the beam as shown in Index 450-511 or Index 450-512.

Prestressed Beam Suppliers typically utilize side forms for casting which are not easily or economically modified. If modifications to beam cross-sections are required for any reason other than haunched sections, maintain profile dimensions of the form. For example: To thicken the web, increase the spacing between side forms. To increase the beam height, increase the thickness of the top flange. In any case, do not reduce the standard thickness of either the top or bottom flange.

See additional instructions in the **SDG**.

Plan Content Requirements

In the Structures Plans:

Complete the following "FLORIDA-I BEAM - TABLE OF BEAM VARIABLES" and include it in the plans. Use additional sheets when the actual number of beams or strand patterns exceeds the capacity of a single plan sheet using the standard table. Supplemental details and modifications are permitted if special conditions require dimensions, details or notes. However, the "FLORIDA-I BEAM - TABLE OF BEAM VARIABLES" itself should not be modified. See **FDM 115** for more information regarding use of Data Tables.

Report elastic and time dependent shortening effects (DIM R) at mid-height of the beam @ 120 days. The average of the calculated values for the top and bottom of the beam may be used.

Report DIM P for beams placed on grade if the calculated value is equal or greater than 1" using 1/8" increments. Also consider the effect of beam end rotations for Florida-I 84 and 96 beams, if significant. Different "P" dimensions at each end may be necessary for accommodating these effects, which will require modifying the "FLORIDA-I BEAM - TABLE OF BEAM VARIABLES" using suggested DIM P1 and DIM P2.

Show strands in the outermost positions of the two lowest rows to support Bars D.

Round Angle Φ up to the nearest degree.

Specify shear stirrup spacing V1 for Bars 5K to the nearest inch.

Prepare a Framing Plan for bridges meeting the criteria stated in the **SDM**.

When diaphragms are required by design, show them on the Framing Plan. Tabulate insert locations with respect to the beam ends and beam faces. Include length adjustments for beams placed on grade and for elastic and time dependent shortening effects. See **SDM** Chapter 15 for preferred diaphragm and reinforcing details.

For bridge widenings where beam ends are encased in full height diaphragms and the diaphragms are to be extended, modify Index 450-010 and the appropriate Index associated with the specific beam height and include them in the plans as follows:

- Modify the Standard Plans in accordance with Method 1, Method 2 or Method 3 as defined in the Terms Of Use for the Borderless DGNs provided in the Standard Plans eBooklet.
- Remove all notes, call-outs and details regarding cutting the strands and coating the ends of the beams with epoxy.
- Insert all notes, call-outs and details to ensure proper placement of Bars 4L as shown in the 2010 Design Standards Index 20010 Series Interims Dated 01/01/10 (Effective Date: July 1, 2010). Detail the number of bars, bar locations and bar bending diagrams.

Payment

Item number	Item Description	Unit Measure
450-2-AAA	Prestressed Beams: Florida-I Beam	LF

Example Problem

The following example shows the data required for completion of a Florida-I Beam Table of Beam Variables. The example assumes a three span bridge with Florida-I 45 Beams designed for the following conditions:

Live Load: HL-93

No intermediate Diaphragms

Stay-in-Place Metal Forms:

Allowance of 20 PSF non-composite dead load over the projected plan area of the forms (this includes the unit weight of metal forms and the concrete required to fill the form flutes).

Environment (Superstructure): Moderately Aggressive

Bridge Characteristics:

Length: 276 ft.

Width: 51'-1" (out-to-out)

Clear Roadway: 48 ft.

Superstructure:

Three simple spans of prestressed concrete beams with 8-inch composite deck slab (plus ½" sacrificial deck thickness)

Span: 87'-0", 102'-0", 87'-0"

Sidewalk: None

Horizontal Alignment: Straight

Vertical Alignment: 0.00% Grade

Skew Angle: 15 degrees (Right)

Beam Design:

Beam: Florida-I 45 Beam

Spacing:

11'-3", 87' Span (5 Beams)

9'-0", 102' Span (6 Beams)

Design Span Length:

84'-6" (Spans 1 & 3)

99'-8" (Span 2)

LOCATION		CONCRETE PROPERTIES				STND. END PTRN. ELEV. TYPE COND		PLAN VIEW CASE		BRG. PLATE MARK ***		END OF BEAM & BEARING DIMENSIONS **				REINFORCING STEEL																											
SPAN BEAM NO.	BEAM TYPE	CLASS	STRENGTHS (psi)		END 1	END 2	END 1	END 2	END 1	END 2	ANGLE Ø		DIM P	DIM J	DIM K1		DIM K2		BEAM DIMENSIONS *		3C1		3C2		3D1		3D2		3D3		4M1		4M2		4M3		5K		NO. OF SPACES BARS 5K				SP. BARS 5K *
			28 Day	Release							END 1	END 2			END 1	END 2	END 1	END 2	END 1	END 2	DIM L	DIM R	C	C	A	B	A	B	NO.	D	D	NO.	NO.	S1	S2	S3	S4	V1					
1	1-5	45	V	6500	5000	2	1	2	2	1-1	1-2	75°	75°	-	7½"	1'-3½"	1'-1½"	85'-10½"	1"	1'-6¼"	1'-6¼"	8¾"	1'-3½"	8¾"	1'-3½"	100	3'-9½"	3'-9½"	73	148	16	35	-	2	6"								
2	1-6	45	V	6500	5000	1	1	2	2	2-1	2-2	75°	75°	-	7½"	1'-11½"	1'-1½"	101'-0¾"	1¼"	1'-6¼"	1'-6¼"	8¾"	1'-3½"	8¾"	1'-3½"	120	3'-9½"	3'-9½"	88	136	10	13	10	14	6"								
3	1-5	45	V	6500	5000	2	1	2	2	3-1	3-2	75°	75°	-	7½"	1'-1½"	1'-3½"	85'-10½"	1"	1'-6¼"	1'-6¼"	8¾"	1'-3½"	8¾"	1'-3½"	100	3'-9½"	3'-9½"	73	148	16	35	-	2	6"								

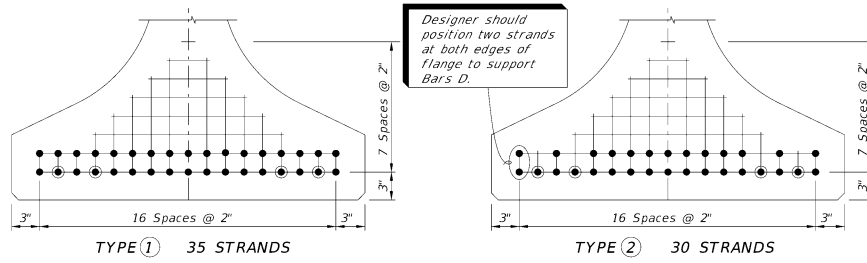

NOTE: Work this sheet with Standard Plans Index 450-010 and the applicable "Florida-I Beam Standard Details" Index.

- STRAND DEBONDING LEGEND**
- - fully bonded strands.
 - ◉ - strands debonded 10'-0" from end of beam.
 - ◻ - Not Used
 - ◈ - Not Used

DIMENSION NOTES

* All longitudinal beam dimensions shown on this sheet with a single asterisk (*) are measured along the centerline of beam. Dimension "R" is calculated at mid-height of the beam.

** End beam bearing dimensions "J" and "K" are measured perpendicular to \bar{C} Bearing along the bottom of the beam.

NOTE: On beams with skewed ends, the debonded length shall be measured along the shielded strand.

BEARING PLATES

*** See the Bearing Plate Data Table for details.

STRAND DESCRIPTION: Use 0.6 Diameter, Grade 270, Low Relaxation Carbon Steel Strands stressed at 44 kips each. Area per strand equals 0.217 sq. in.

STRAND PATTERNS

REVISIONS						STATE OF FLORIDA DEPARTMENT OF TRANSPORTATION				SHEET TITLE		REF. DWG. NO.		
Date	By	Description	Date	By	Description	Drawn By	Checked by	Designed by	Checked by	ROAD NO.	COUNTY	FINANCIAL PROJECT ID	PROJECT NAME	SHEET NO.
						XXX MM-YY	XXX MM-YY	XXX MM-YY	XXX MM-YY				SAMPLE	

Design Aids

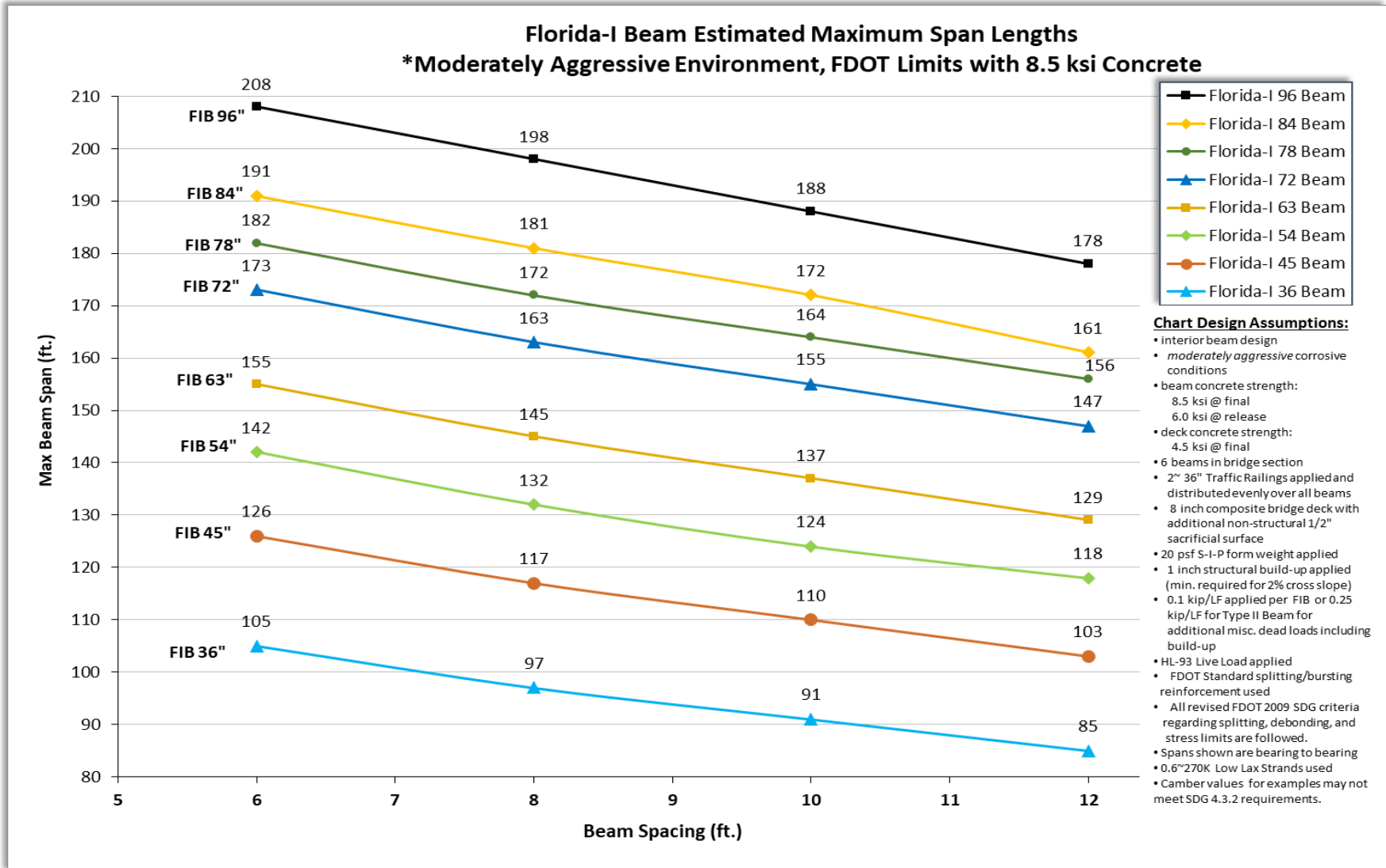

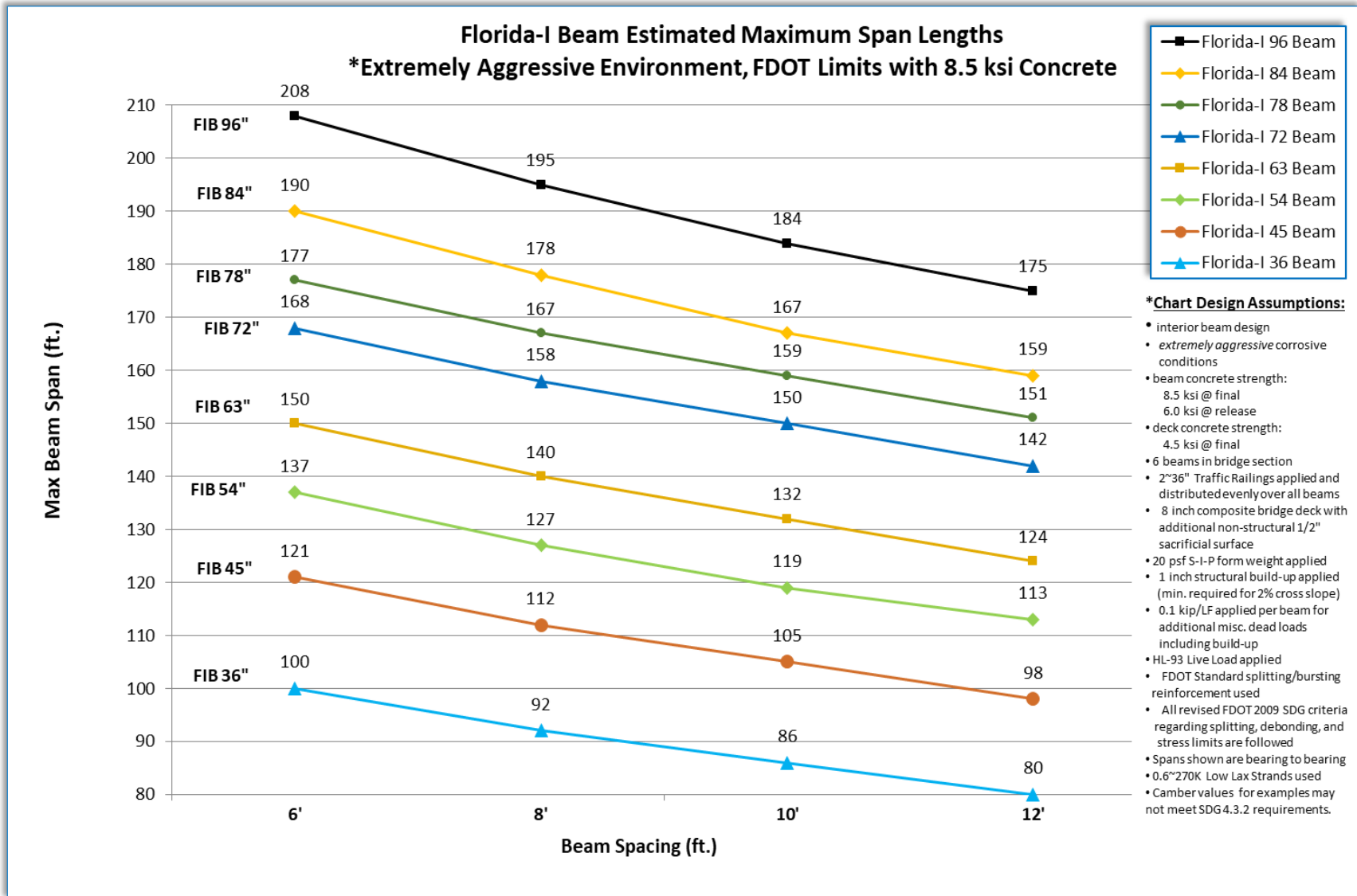

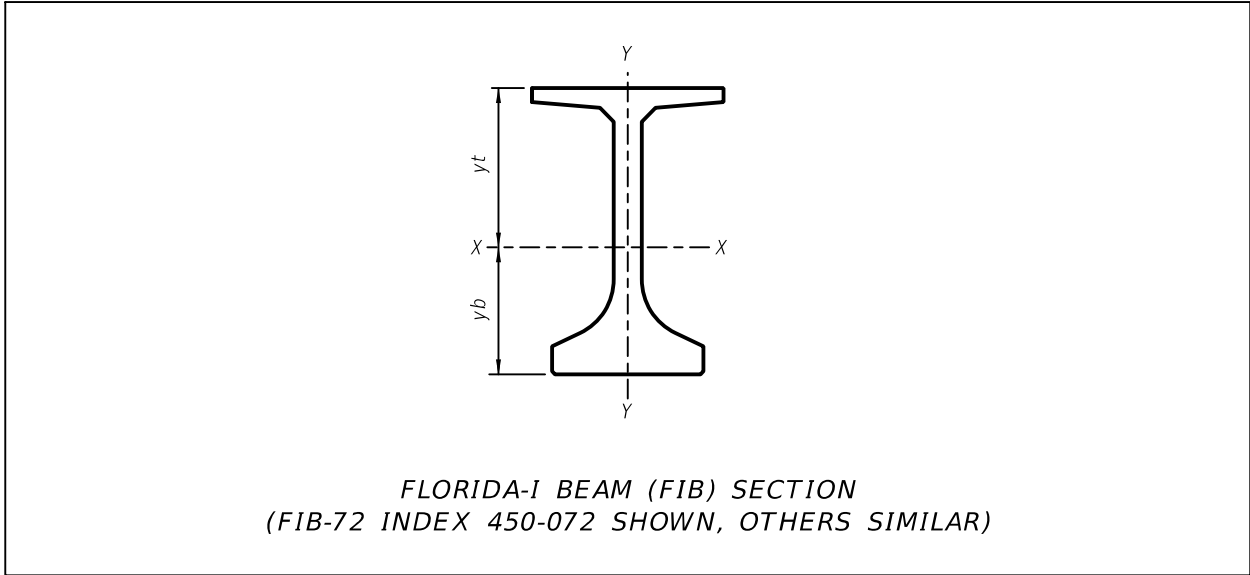

Section Properties						
Beam Size	Area (in.²)	Perimeter (in.)	I_{xx} (in.⁴)	I_{yy} (in.⁴)	yt (in.)	y_b (in.)
FIB-36	806.58	206.57	127,545	81,070	19.51	16.49
FIB-45	869.58	224.57	226,581	81,327	24.79	20.21
FIB-54	932.58	242.57	359,929	81,584	29.96	24.04
FIB-63	995.58	260.57	530,313	81,842	35.04	27.96
FIB-72	1,058.58	278.57	740,416	82,099	40.06	31.94
FIB-78	1,100.58	290.57	903,861	82,270	43.37	34.63
FIB-84	1,142.58	302.57	1.087 x 10 ⁶	82,442	46.66	37.34
FIB-96	1,226.58	326.57	1.515 x 10 ⁶	82,785	53.18	42.82