

| TABLE OF CONTENTS: |   |
|--------------------|---|
| Sheet              | Description                             |
| 1                  | General Notes and Contents              |
| 2                  | Conduit, Wiring, and Foundation Details |
| 3                  | Spread Footing Foundation               |
| 4                  | Roadside Sign Assembly-1                |
| 5                  | Roadside Sign Assembly-2                |
| 6                  | Roadside Sign Assembly-3                |
| 7                  | Roadside Sign Assembly-4                |
| 8                  | Roadside Sign Assembly-5                |
| 9                  | Roadside Sign Assembly-6                |
| 10                 | Roadside Sign Assembly-7                |
| 11                 | Roadside Sign Assembly-8                |
| 12                 | Roadside Sign Assembly-9                |
| 13                 | Roadside Sign Assembly-10               |
| 14                 | Roadside Sign Assembly-11               |
| 15                 | Overhead Sign Assembly                  |

**GENERAL NOTES:**

1. Meet the requirements of Specifications 646 and 700.
2. Engage all threads on the transformer base and post unless the aluminum post is fully seated into base.
3. Install a concrete slab around all roadside assemblies on slopes 6:1 or greater. The minimum slab dimension is 6" by 4'-0" by 5'-0".
4. When wire entry holes are drilled in the sign column, use a bushing or rubber grommet to protect conductors.

**POWER CONFIGURATION 'B' NOTES:**

1. Install a separate pole for mounting the solar panel, controller and batteries for all roadside assemblies with solar panels, controllers and batteries weighing more than 170 lbs.
2. Install the auxiliary pole as close to the right of way boundary as possible.
3. Install the auxiliary pole so that the height is the same as the column for the roadside assembly.
4. Orient solar panel to face South for optimal exposure to sunlight.
5. The controller and the solar batteries may be located in the same compartment.

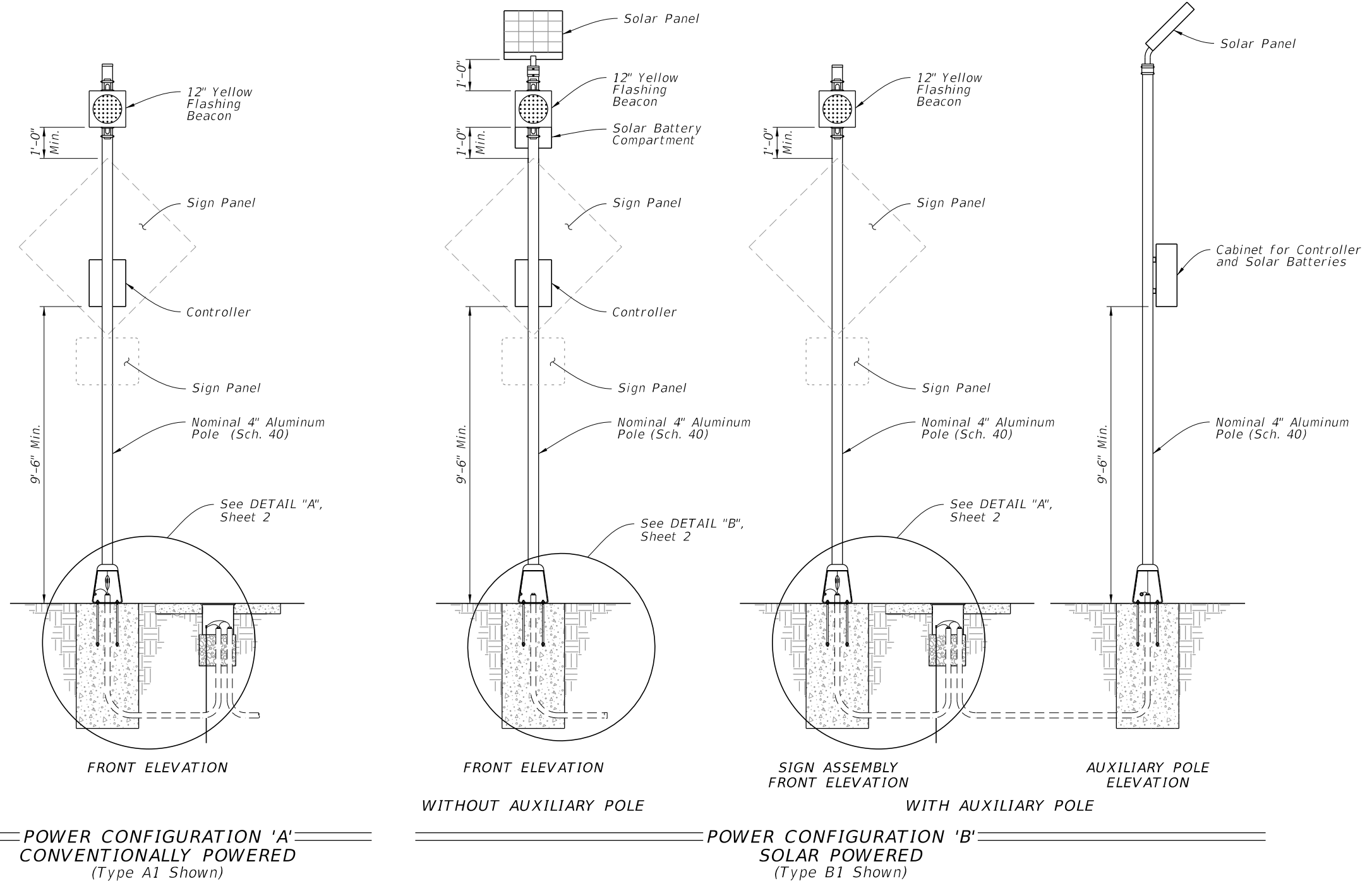

POWER CONFIGURATION 'A'  
CONVENTIONALLY POWERED  
(Type A1 Shown)

WITHOUT AUXILIARY POLE

POWER CONFIGURATION 'B'  
SOLAR POWERED  
(Type B1 Shown)

AUXILIARY POLE  
ELEVATION

10/3/2023 3:17:37 PM

10/3/2023 3:17:44 PM

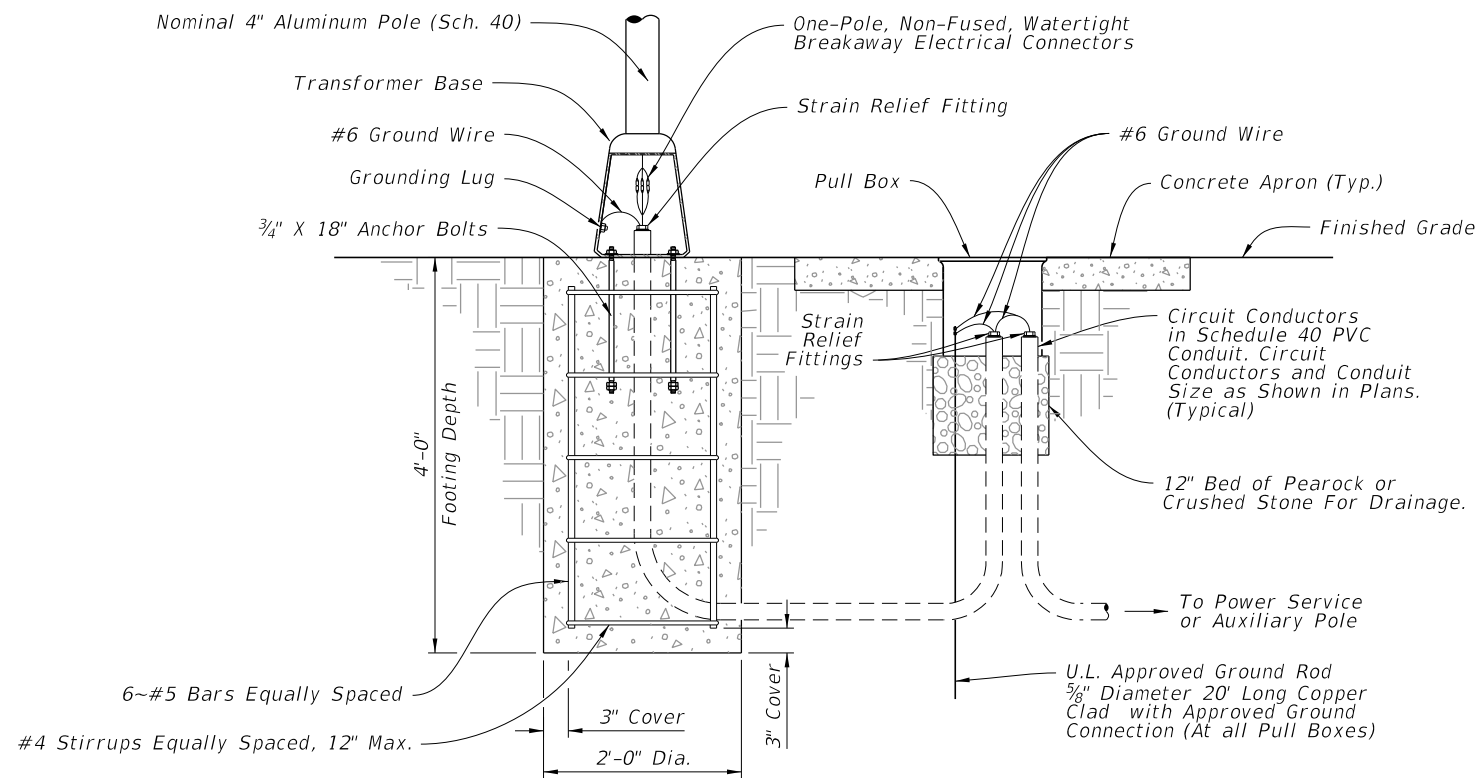

DETAIL "A"

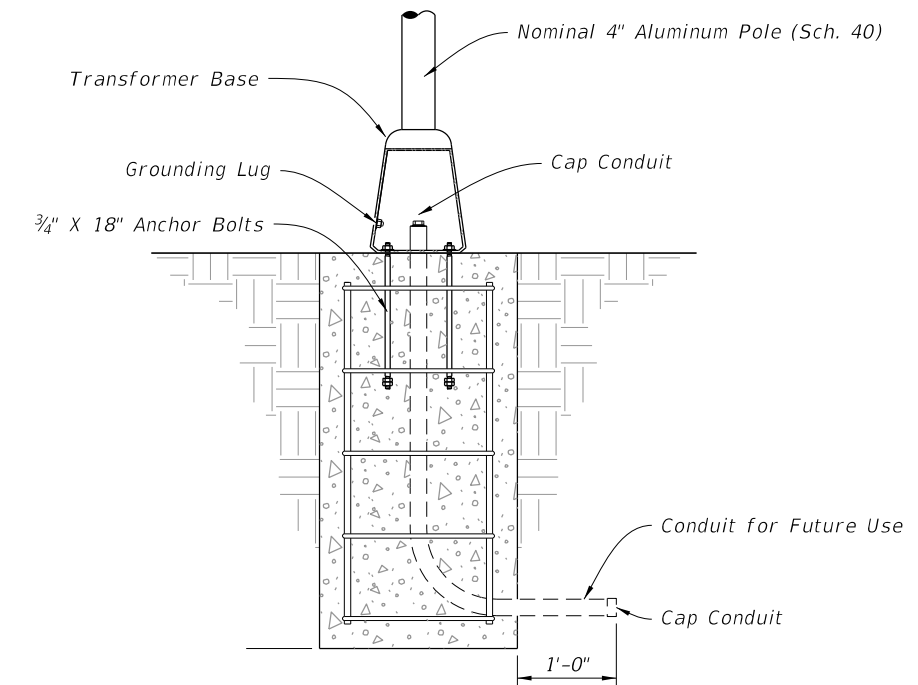

DETAIL "B"

CONDUIT, WIRING, AND FOUNDATION DETAILS

|                                   |                                     |  |  |                          |                          |
|-----------------------------------|-------------------------------------|--|--|--------------------------|--------------------------|
| <p>LAST REVISION<br/>11/01/23</p> | <p>REVISION</p> <p>DESCRIPTION:</p> |  <p>FY 2024-25<br/>STANDARD PLANS</p> | <p>ENHANCED HIGHWAY SIGNING ASSEMBLIES</p> | <p>INDEX<br/>700-120</p> | <p>SHEET<br/>2 of 15</p> |
|-----------------------------------|-------------------------------------|--|--|--------------------------|--------------------------|

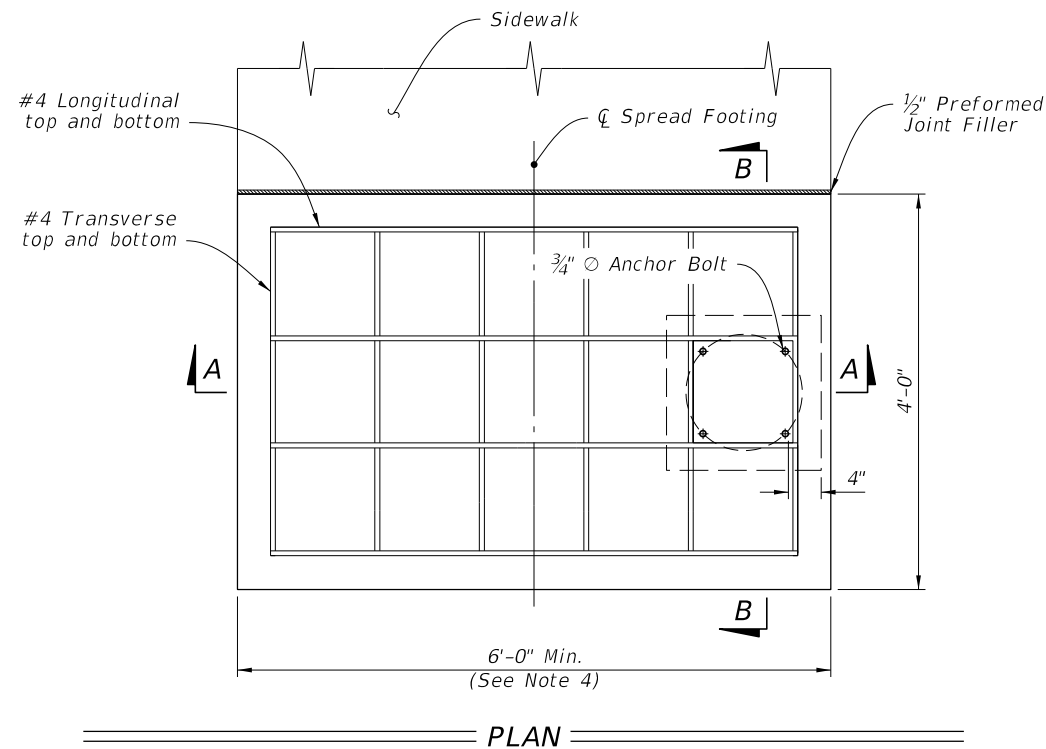

**NOTES:**

1. Install the Spread Footing Foundation only where called for in the Plans.
2. SIDEWALK:
  - a. When abutting sidewalk, match the cross slope of the adjacent sidewalk or curb ramp where applicable. Maintain the minimum depth of footing.
  - b. 1/2" expansion preformed joint filler required between sidewalk and spread footing.
  - c. Apply concrete surface finish to the top of the spread footing in accordance with Specification 522-7.
  - d. Sidewalk placed on the other side or both sides of the spread footing is permitted where shown in the Plans.
3. Only use concrete riser when installed in-line with sidewalk curb that results in a drop off to the adjacent sidewalk.
4. For sidewalks greater than 6', match sidewalk width. Add one #4 transverse bar, top and bottom, per additional foot of spread footing to maintain at minimum the same reinforcement area per foot.
5. Base location can vary on spread footing. Location shown in Plans.

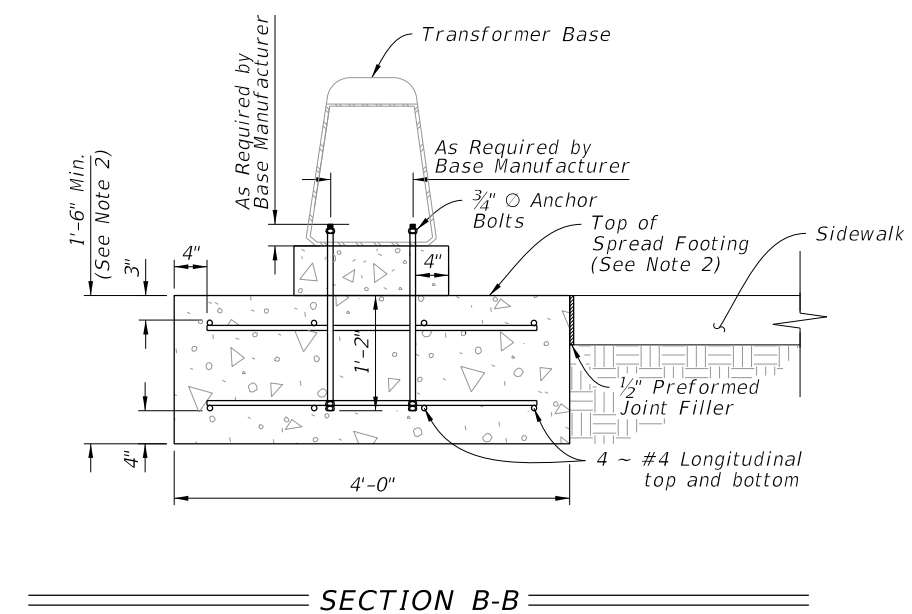
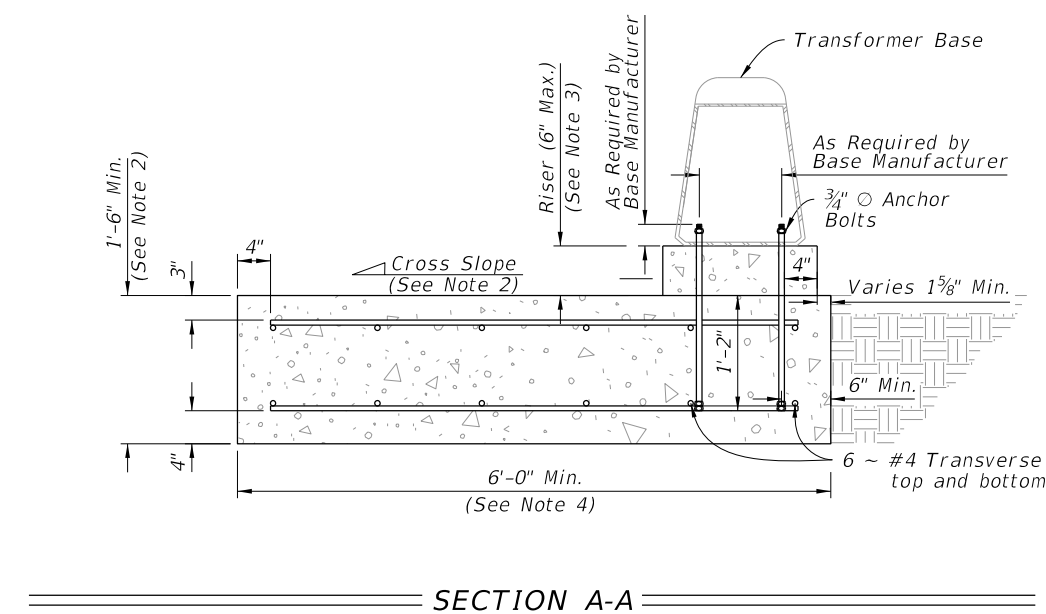

10/3/2023 3:17:50 PM

**SPREAD FOOTING FOUNDATION**

|                           |              |  |                                     |                  |                  |
|---------------------------|--------------|--|-------------------------------------|------------------|------------------|
| LAST REVISION<br>11/01/23 | DESCRIPTION: |  FY 2024-25<br>STANDARD PLANS | ENHANCED HIGHWAY SIGNING ASSEMBLIES | INDEX<br>700-120 | SHEET<br>3 of 15 |
|---------------------------|--------------|--|-------------------------------------|------------------|------------------|

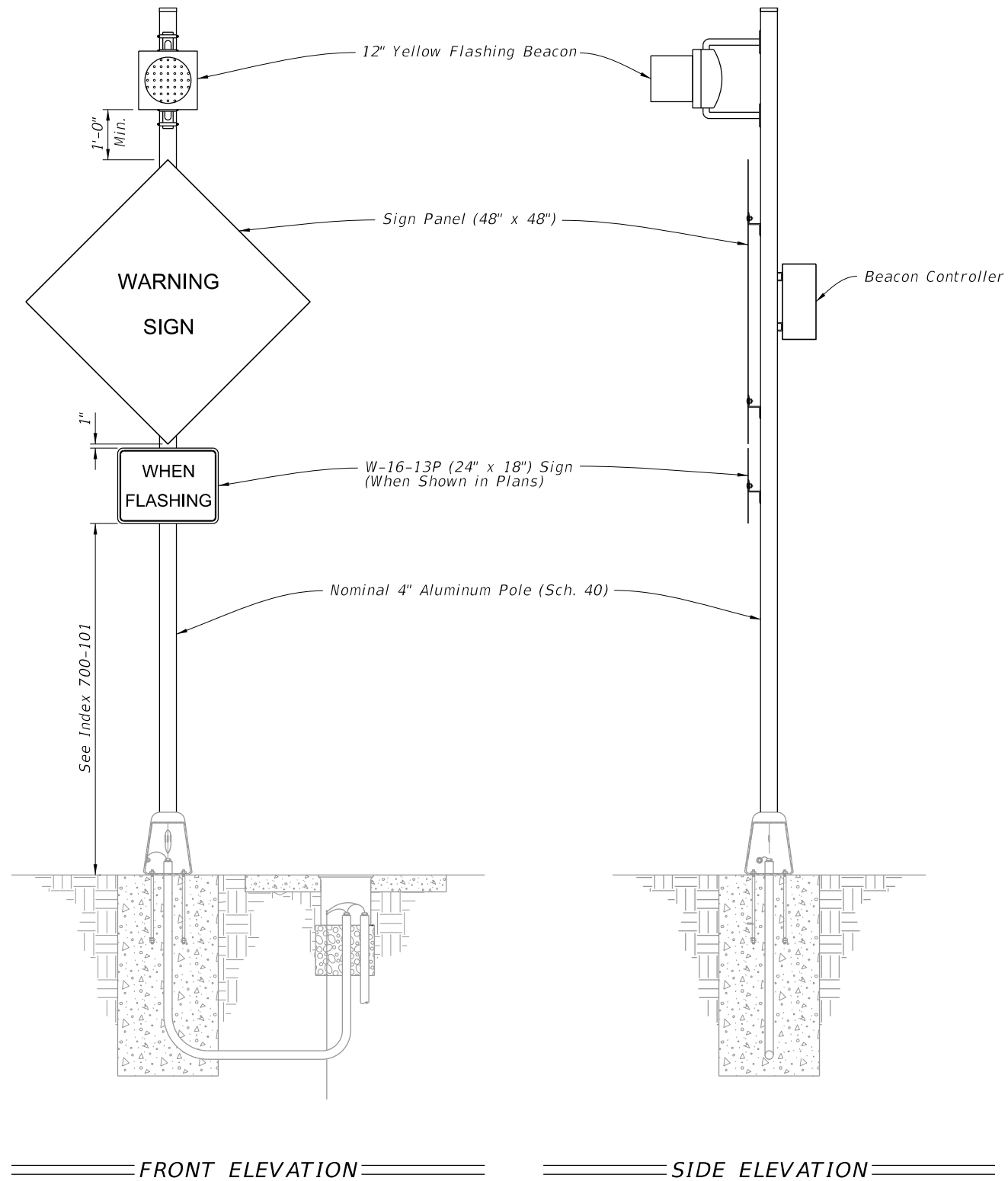

**NOTES:**

- 1. Type A1 Assembly (conventionally powered) is shown.  
Type B1 Assemblies (solar powered) similar.
- 2. Foundation reinforcement not shown.

10/3/2023 3:17:56 PM

|                              |          |              |   |                                     |                  |                  |
|------------------------------|----------|--------------|---|-------------------------------------|------------------|------------------|
| LAST<br>REVISION<br>11/01/23 | REVISION | DESCRIPTION: | <br>FY 2024-25<br>STANDARD PLANS | ENHANCED HIGHWAY SIGNING ASSEMBLIES | INDEX<br>700-120 | SHEET<br>4 of 15 |
|------------------------------|----------|--------------|---|-------------------------------------|------------------|------------------|

10/27/2023 9:03:59 AM

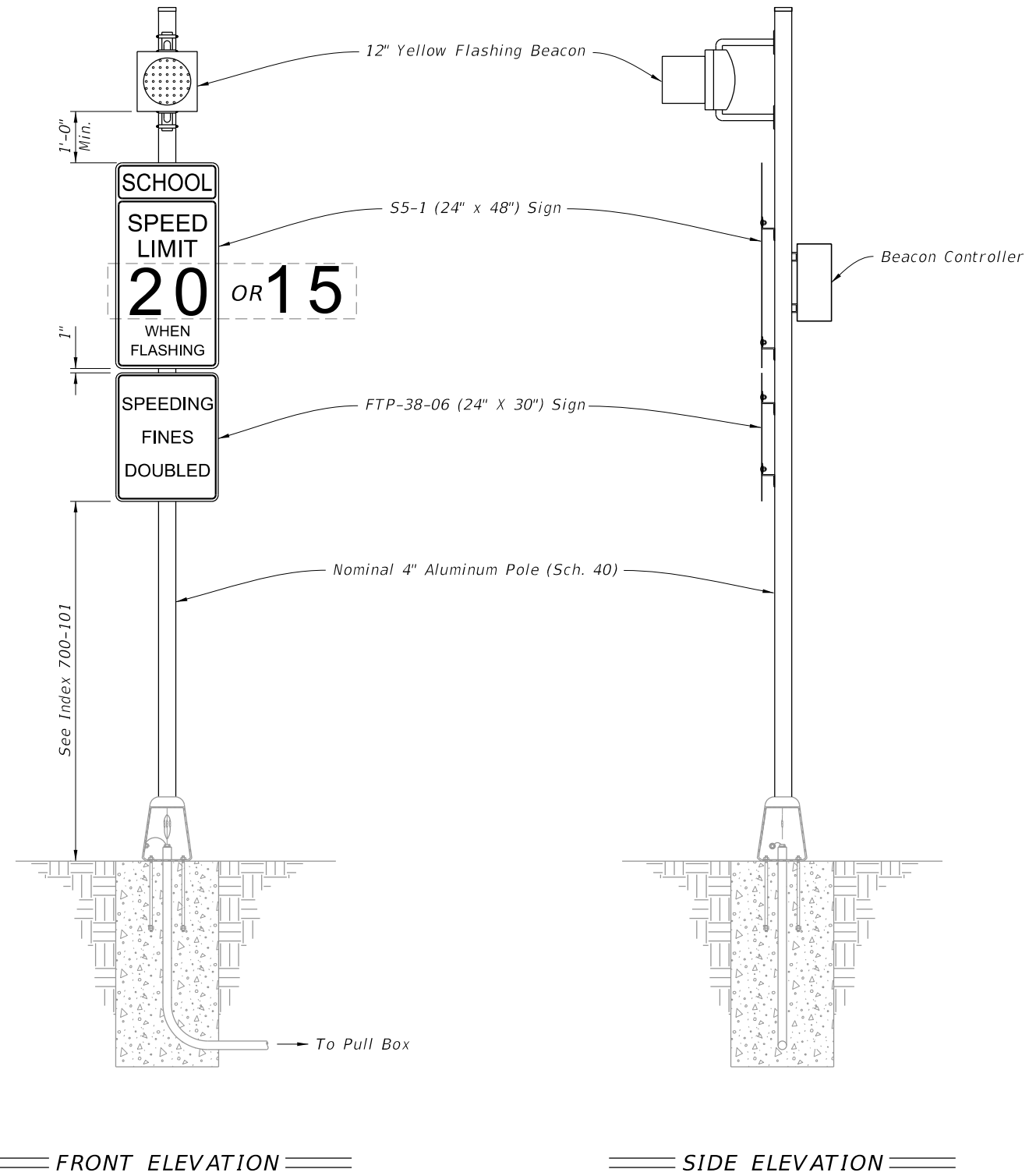

- NOTES:**
1. Type A2 Assembly (conventionally powered) is shown. Type B2 Assemblies (solar powered) similar.
  2. Foundation reinforcement not shown.

**ROADSIDE SIGN ASSEMBLY-2**

|                           |              |
|---------------------------|--------------|
| LAST REVISION<br>11/01/23 | DESCRIPTION: |
|---------------------------|--------------|



FY 2024-25  
STANDARD PLANS

ENHANCED HIGHWAY SIGNING ASSEMBLIES

INDEX  
700-120

SHEET  
5 of 15

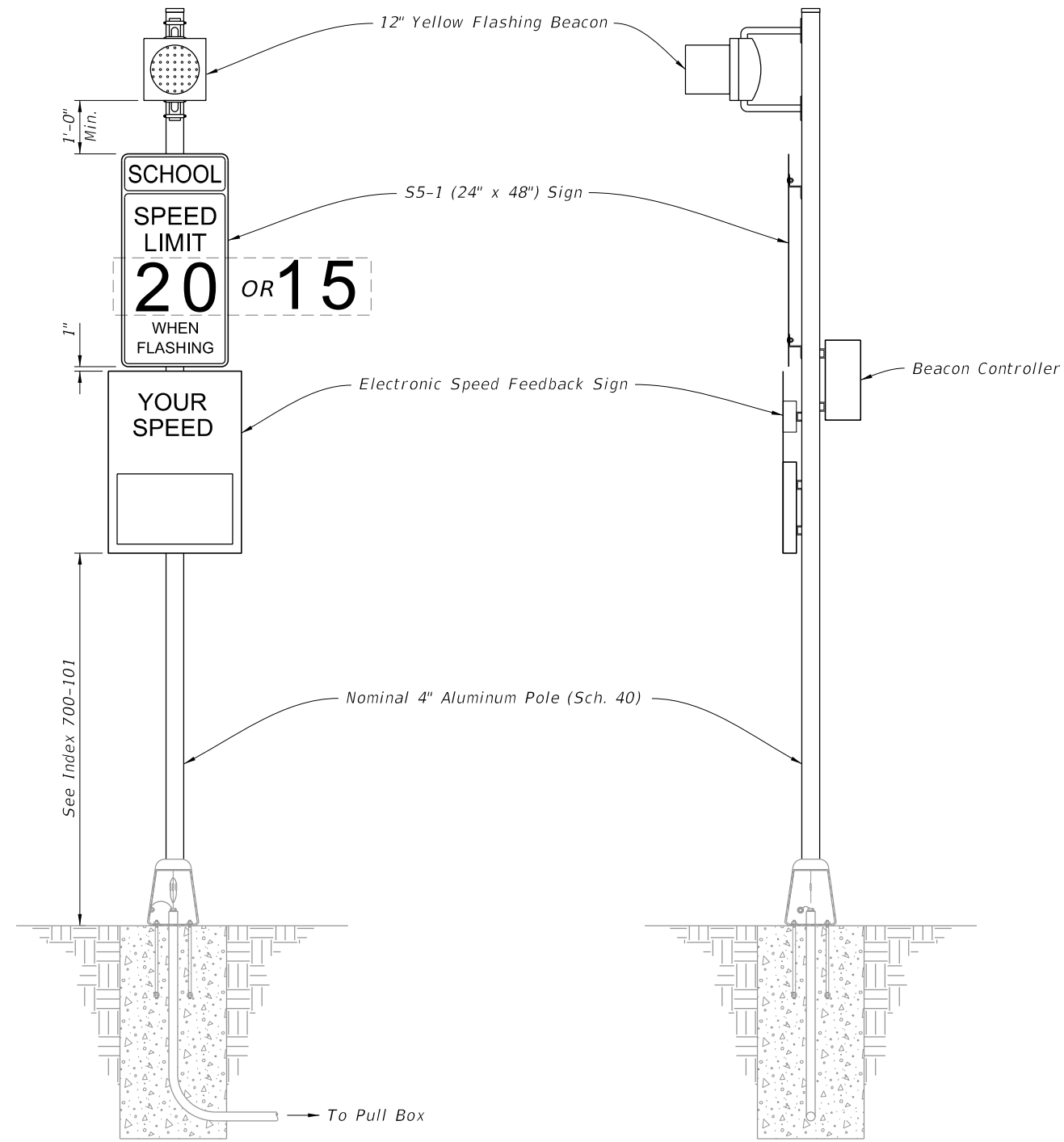

FRONT ELEVATION

SIDE ELEVATION

**NOTES:**

1. Type A3 Assembly (conventionally powered) is shown. Type B3 Assemblies (solar powered) similar.
2. Use electronic speed feedback sign with 15" high numerals for posted speed of 45 mph or less, and 18" high numerals for posted speeds greater than 45 mph.
3. Foundation reinforcement not shown.

10/3/2023 3:18:11 PM

**ROADSIDE SIGN ASSEMBLY-3**

|                           |          |              |   |                                     |                  |                  |
|---------------------------|----------|--------------|---|-------------------------------------|------------------|------------------|
| LAST REVISION<br>11/01/23 | REVISION | DESCRIPTION: | <br>FY 2024-25<br>STANDARD PLANS | ENHANCED HIGHWAY SIGNING ASSEMBLIES | INDEX<br>700-120 | SHEET<br>6 of 15 |
|---------------------------|----------|--------------|---|-------------------------------------|------------------|------------------|

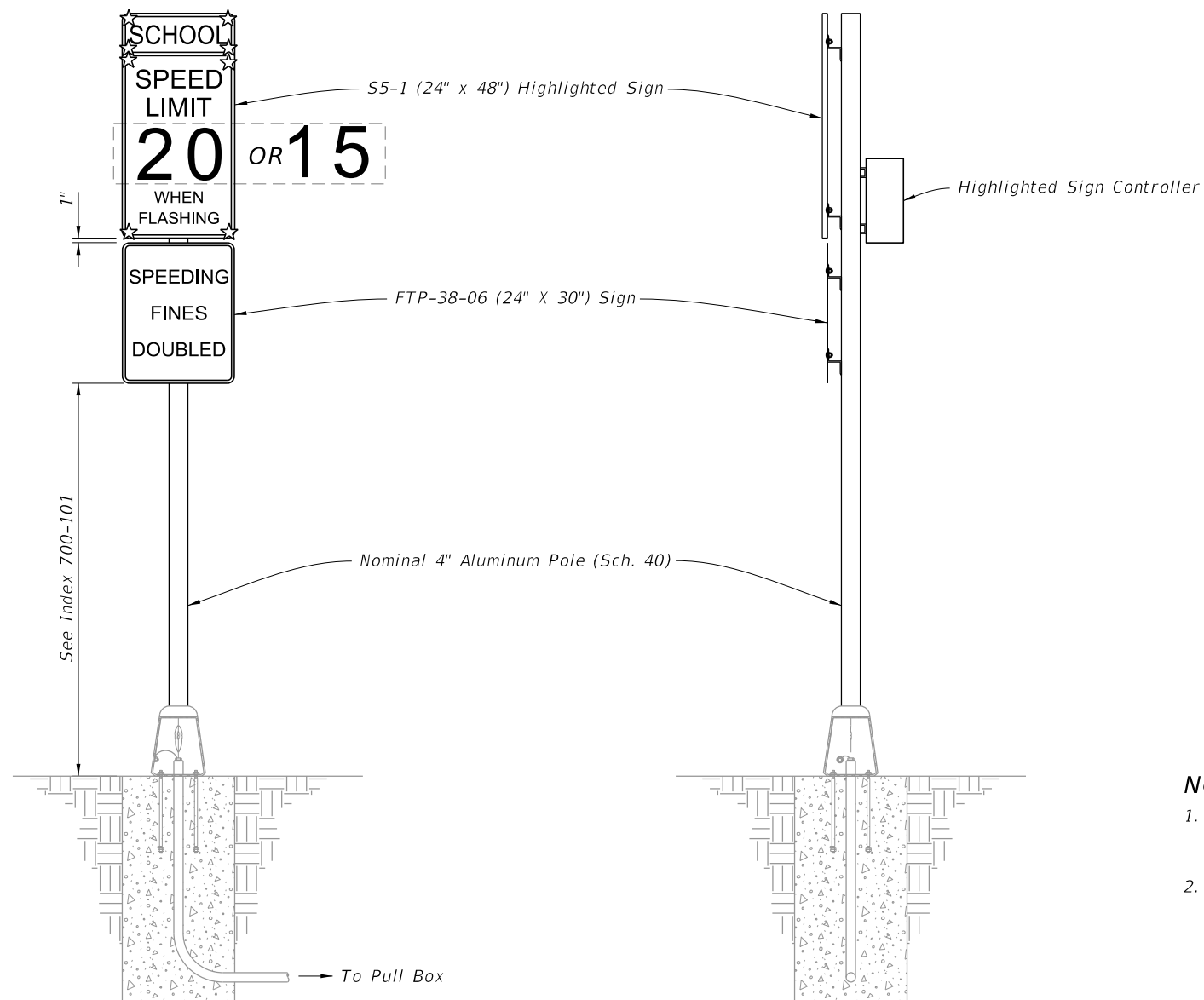

FRONT ELEVATION

SIDE ELEVATION

**NOTES:**

- 1. Type A4 Assembly (conventionally powered) is shown. Type B4 Assemblies (solar powered) similar.
- 2. Foundation reinforcement not shown.

10/3/2023 3:18:19 PM

**ROADSIDE SIGN ASSEMBLY-4**

|                           |          |              |   |                                     |                  |                  |
|---------------------------|----------|--------------|---|-------------------------------------|------------------|------------------|
| LAST REVISION<br>11/01/23 | REVISION | DESCRIPTION: | <br>FY 2024-25<br>STANDARD PLANS | ENHANCED HIGHWAY SIGNING ASSEMBLIES | INDEX<br>700-120 | SHEET<br>7 of 15 |
|---------------------------|----------|--------------|---|-------------------------------------|------------------|------------------|

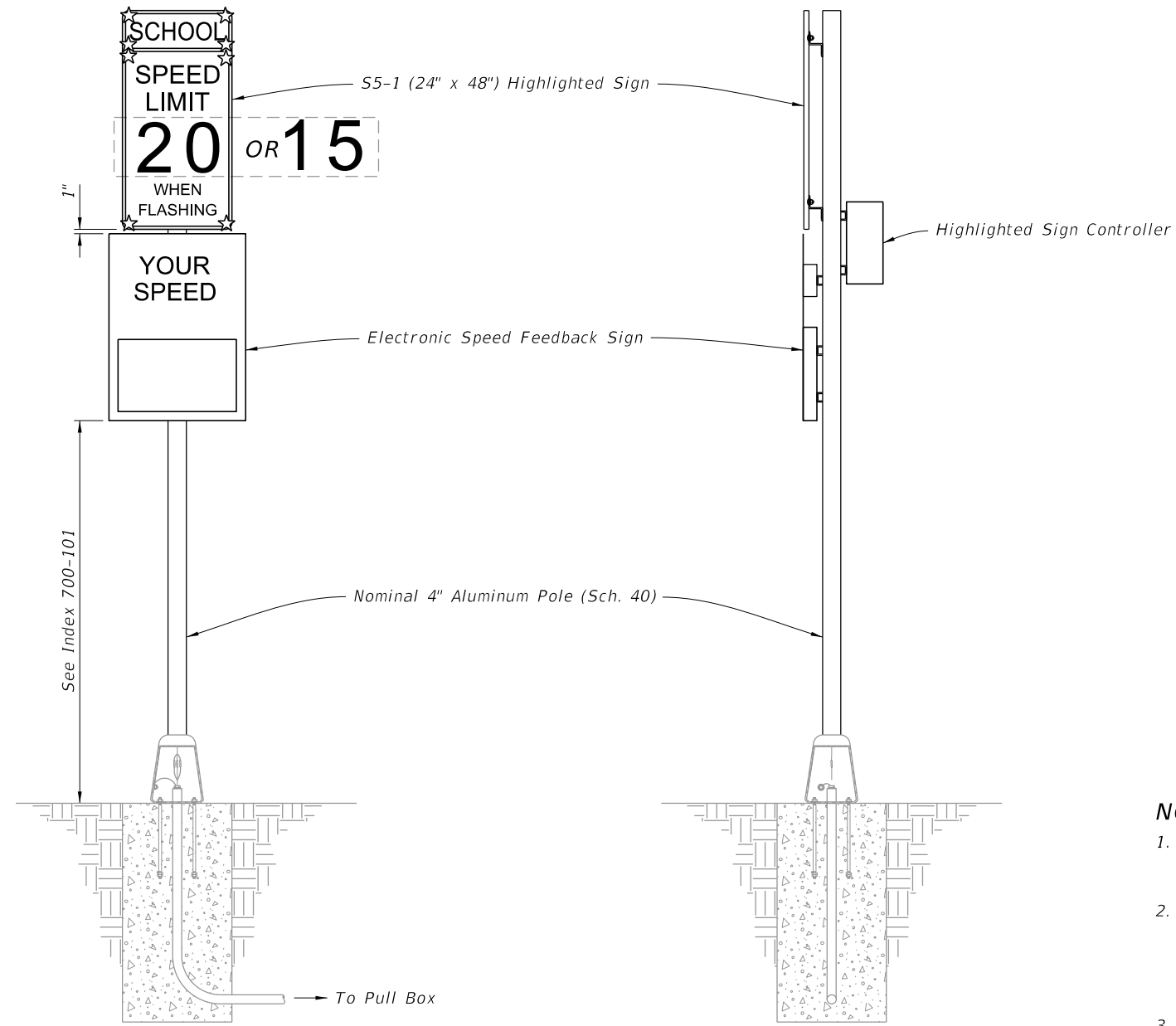

==== FRONT ELEVATION ====

==== SIDE ELEVATION ====

- NOTES:**
1. Type A5 Assembly (conventionally powered) is shown. Type B5 Assemblies (solar powered) similar.
  2. Use electronic speed feedback sign with 15" high numerals for posted speed of 45 mph or less, and 18" high numerals for posted speeds greater than 45 mph.
  3. Foundation reinforcement not shown.

10/3/2023 3:18:25 PM

|                           |              |   |                                     |                  |                  |
|---------------------------|--------------|---|-------------------------------------|------------------|------------------|
| LAST REVISION<br>11/01/23 | DESCRIPTION: |  FY 2024-25<br>STANDARD PLANS | ENHANCED HIGHWAY SIGNING ASSEMBLIES | INDEX<br>700-120 | SHEET<br>8 of 15 |
|---------------------------|--------------|---|-------------------------------------|------------------|------------------|

**ROADSIDE SIGN ASSEMBLY-5**



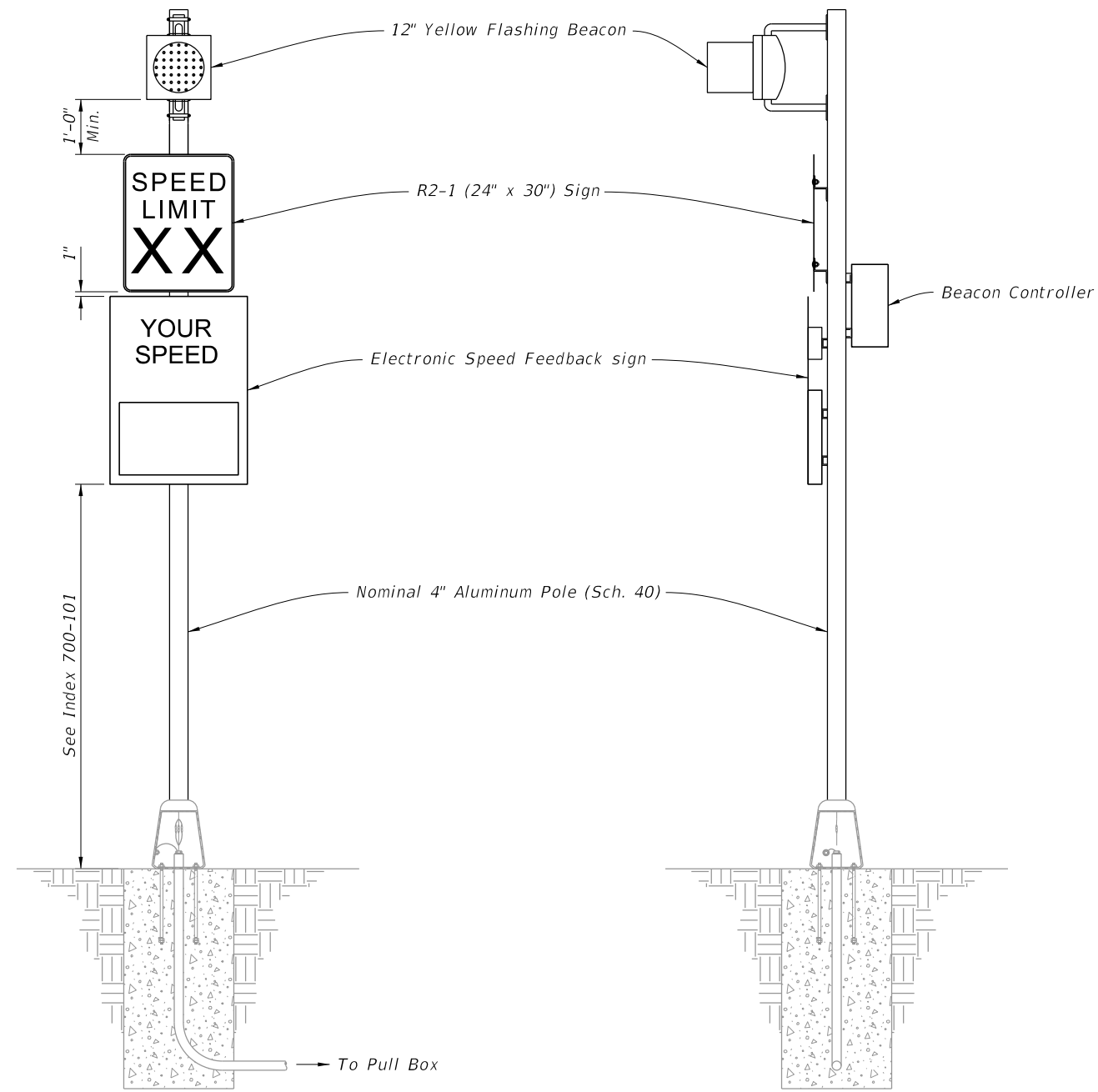

FRONT ELEVATION

SIDE ELEVATION

**NOTES:**

1. Type A6 Assembly (conventionally powered) is shown. Type B6 Assemblies (solar powered) similar.
2. Use electronic speed feedback sign with 15" high numerals for posted speed of 45 mph or less, and 18" high numerals for posted speeds greater than 45 mph.
3. Foundation reinforcement not shown.

10/3/2023 3:18:31 PM

**ROADSIDE SIGN ASSEMBLY-6**

|                           |          |              |   |                                     |                  |                  |
|---------------------------|----------|--------------|---|-------------------------------------|------------------|------------------|
| LAST REVISION<br>11/01/23 | REVISION | DESCRIPTION: | <br>FY 2024-25<br>STANDARD PLANS | ENHANCED HIGHWAY SIGNING ASSEMBLIES | INDEX<br>700-120 | SHEET<br>9 of 15 |
|---------------------------|----------|--------------|---|-------------------------------------|------------------|------------------|

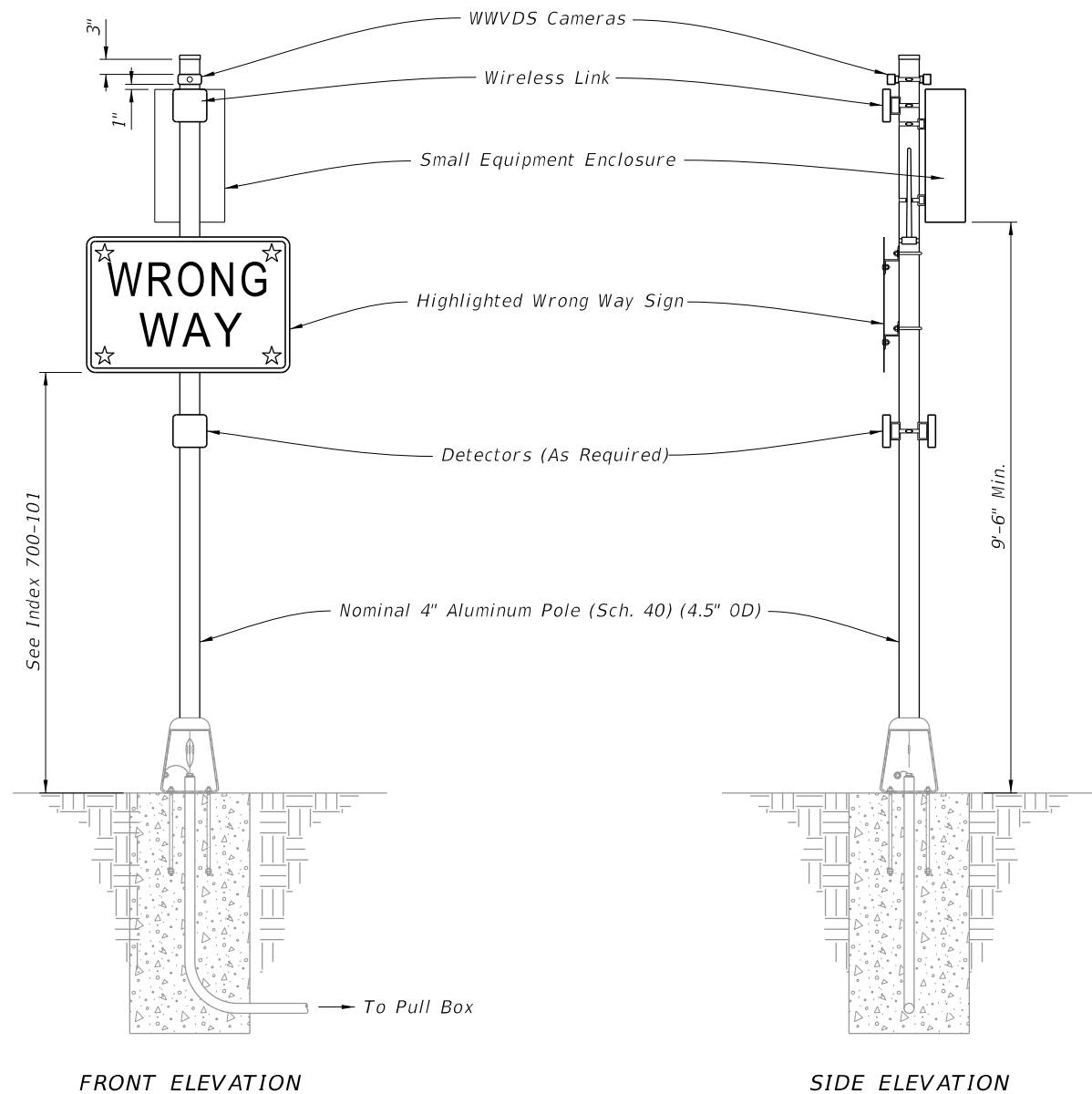

FRONT ELEVATION

SIDE ELEVATION

**WRONG WAY HIGHLIGHTED SIGN ASSEMBLY**

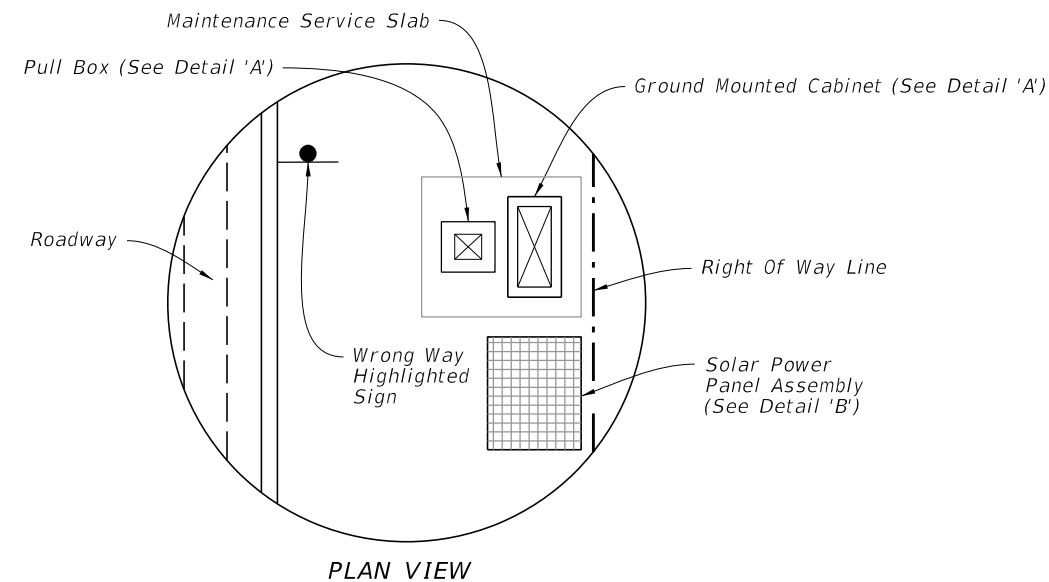

PLAN VIEW

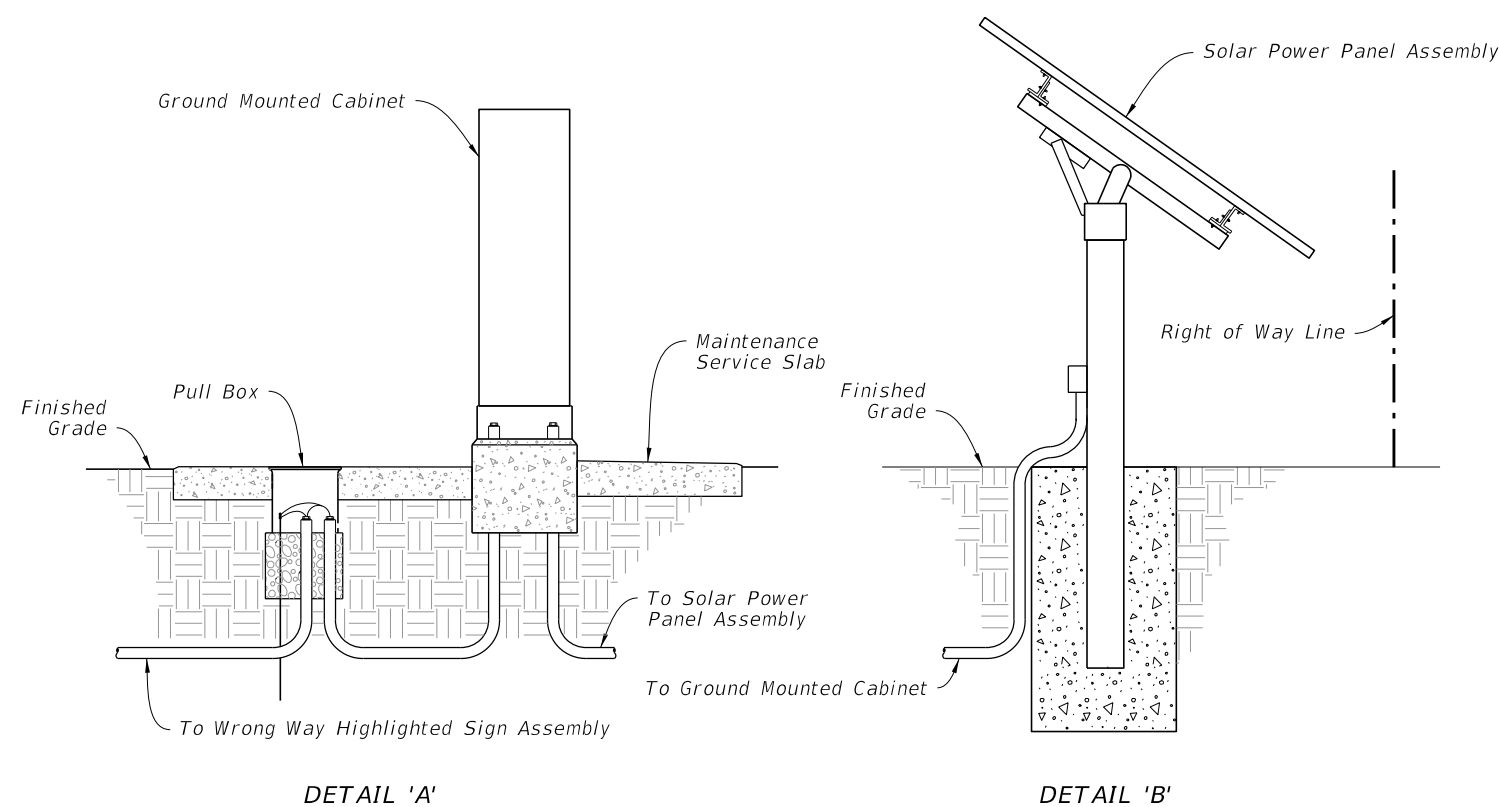

DETAIL 'A'

DETAIL 'B'

**SOLAR POWER ASSEMBLY**

**NOTES:**

1. Install Wrong Way Vehicle Detection System (WWVDS) devices including cameras, detectors, wireless links, antennas, enclosures, and electronics in accordance with the manufacturer's instructions.
2. When a solar powered configuration (Type B7) is called for in the Plans, install a ground mounted cabinet and solar power panel assembly. Install the solar charge controller and batteries in the same ground mounted cabinet. Provide a separate pole for mounting the solar panel (DETAIL 'B' shown for illustration purposes only) and install in accordance with manufacturer's instructions. Locate the Solar Power Assembly as close to the right of way as possible. Orient the solar panel to face South.
3. Foundation reinforcement not shown.
4. Install cabinets in accordance with Index 676-010.

**ROADSIDE SIGN ASSEMBLY-7**

10/3/2023 3:18:36 PM

|                           |          |              |   |  |                  |                   |
|---------------------------|----------|--------------|---|--|------------------|-------------------|
| LAST REVISION<br>11/01/23 | REVISION | DESCRIPTION: | <br><b>FY 2024-25<br/>STANDARD PLANS</b> | <b>ENHANCED HIGHWAY SIGNING ASSEMBLIES</b> | INDEX<br>700-120 | SHEET<br>10 of 15 |
|---------------------------|----------|--------------|---|--|------------------|-------------------|

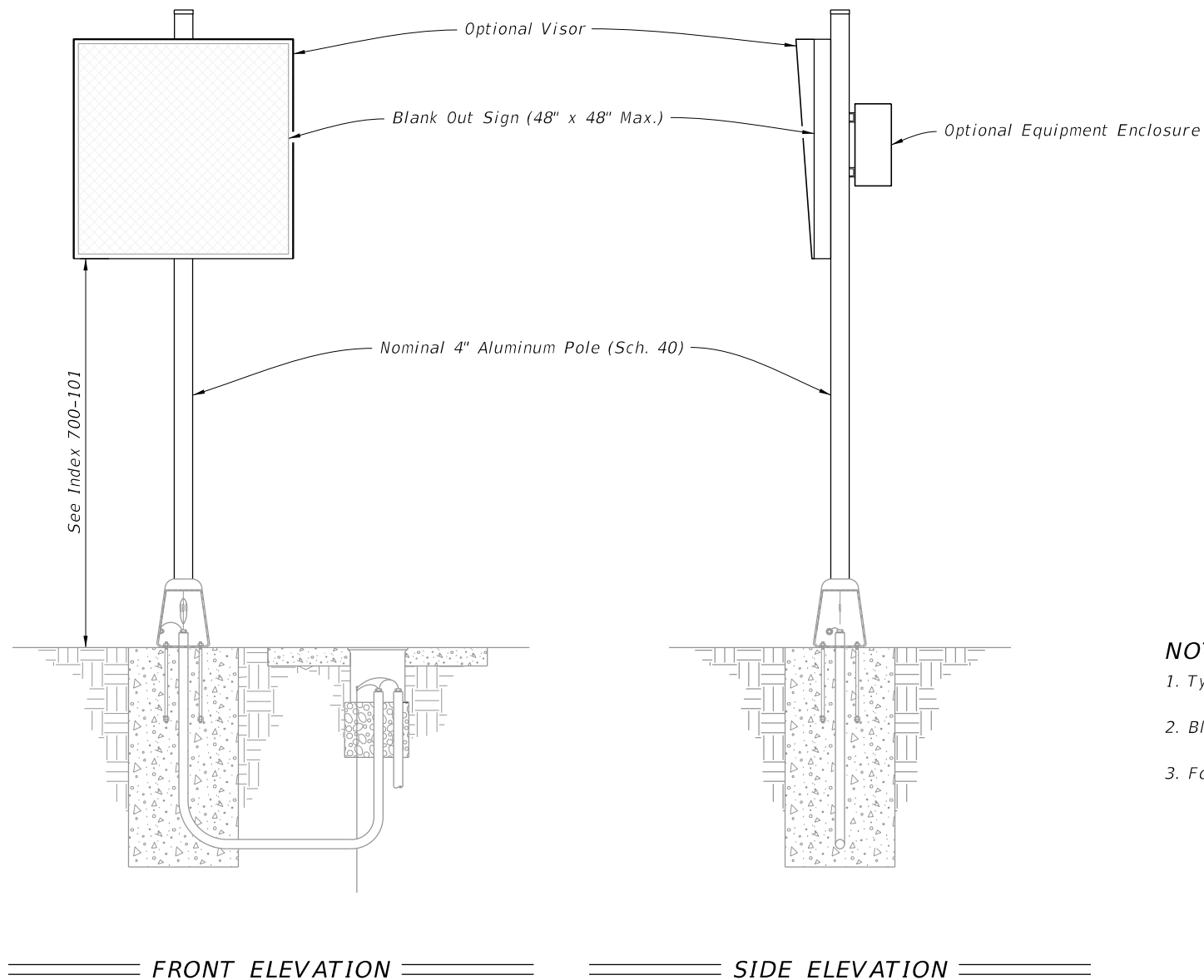

**NOTES:**

- 1. Type A8 Assembly (conventionally powered) is shown.
- 2. Blank Out Sign visors are optional.
- 3. Foundation reinforcement not shown.

10/3/2023 3:18:45 PM

**ROADSIDE SIGN ASSEMBLY-8**

|                           |          |              |   |                                     |                  |                   |
|---------------------------|----------|--------------|---|-------------------------------------|------------------|-------------------|
| LAST REVISION<br>11/01/23 | REVISION | DESCRIPTION: | <br>FY 2024-25<br>STANDARD PLANS | ENHANCED HIGHWAY SIGNING ASSEMBLIES | INDEX<br>700-120 | SHEET<br>11 of 15 |
|---------------------------|----------|--------------|---|-------------------------------------|------------------|-------------------|

10/3/2023 3:18:51 PM

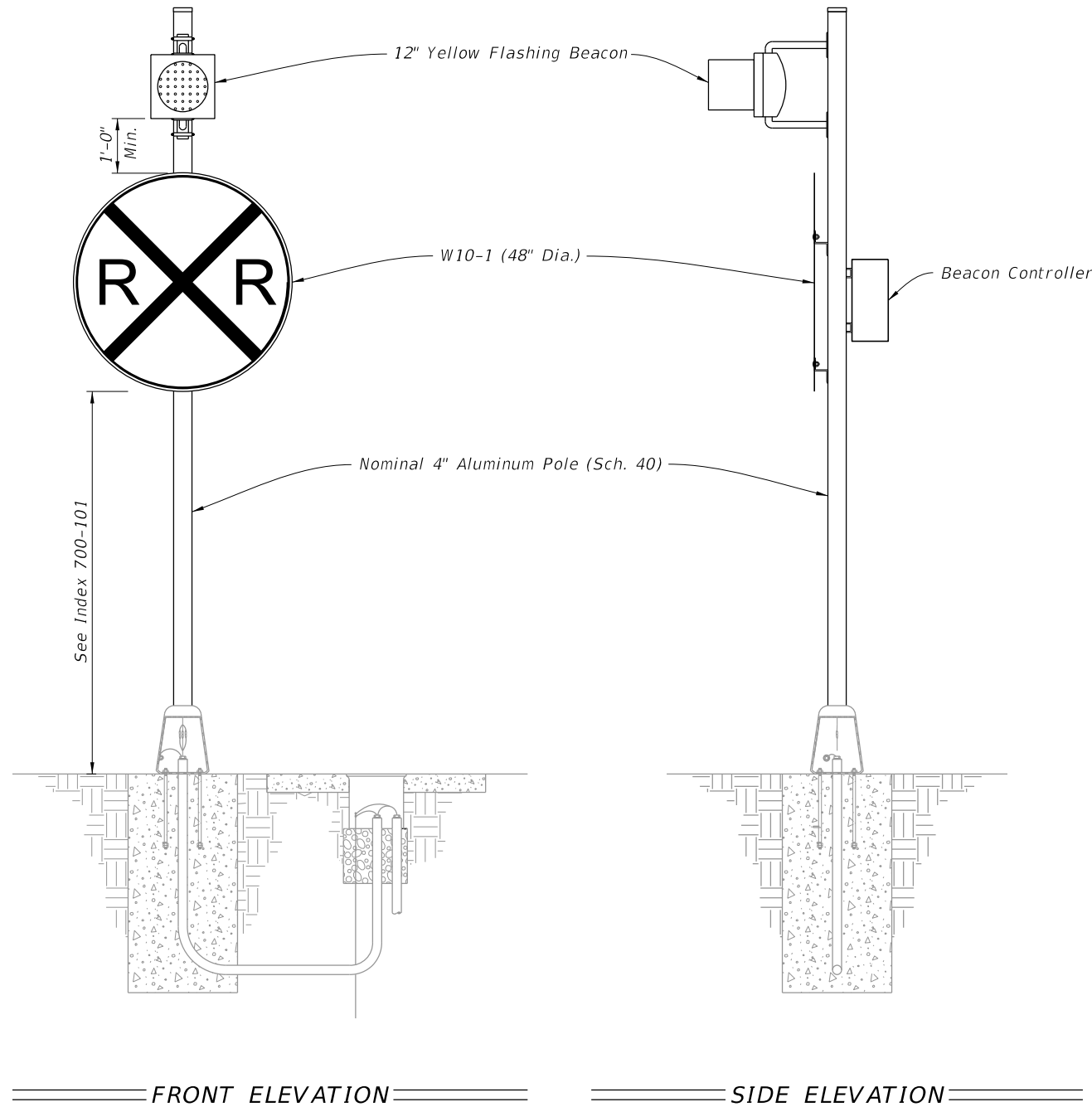

**NOTES:**

- 1. Type A9 Assembly (conventionally powered) is shown.  
Type B9 Assemblies (solar powered) similar.
- 2. Foundation reinforcement not shown.

**ROADSIDE SIGN ASSEMBLY-9**

|                              |          |              |
|------------------------------|----------|--------------|
| LAST<br>REVISION<br>11/01/23 | REVISION | DESCRIPTION: |
|------------------------------|----------|--------------|



FY 2024-25  
STANDARD PLANS

ENHANCED HIGHWAY SIGNING ASSEMBLIES

INDEX  
700-120

SHEET  
12 of 15

10/3/2023 3:18:56 PM

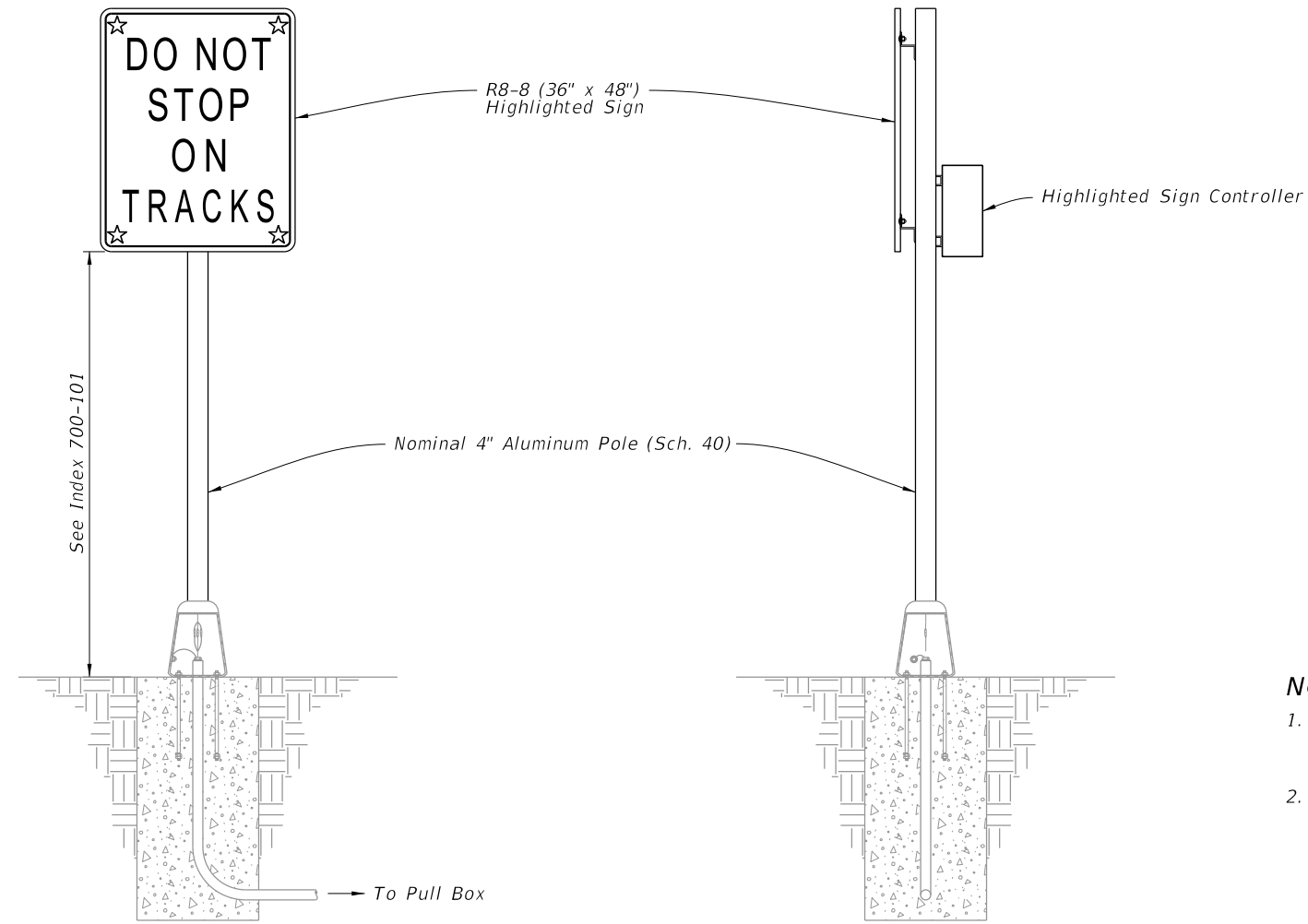

FRONT ELEVATION

SIDE ELEVATION

**NOTES:**

- 1. Type A10 Assembly (conventionally powered) is shown.  
Type B10 Assemblies (solar powered) similar.
- 2. Foundation reinforcement not shown.

**ROADSIDE SIGN ASSEMBLY-10**

|                              |          |              |
|------------------------------|----------|--------------|
| LAST<br>REVISION<br>11/01/23 | REVISION | DESCRIPTION: |
|------------------------------|----------|--------------|



FY 2024-25  
STANDARD PLANS

ENHANCED HIGHWAY SIGNING ASSEMBLIES

INDEX  
700-120

SHEET  
13 of 15

10/3/2023 3:19:05 PM

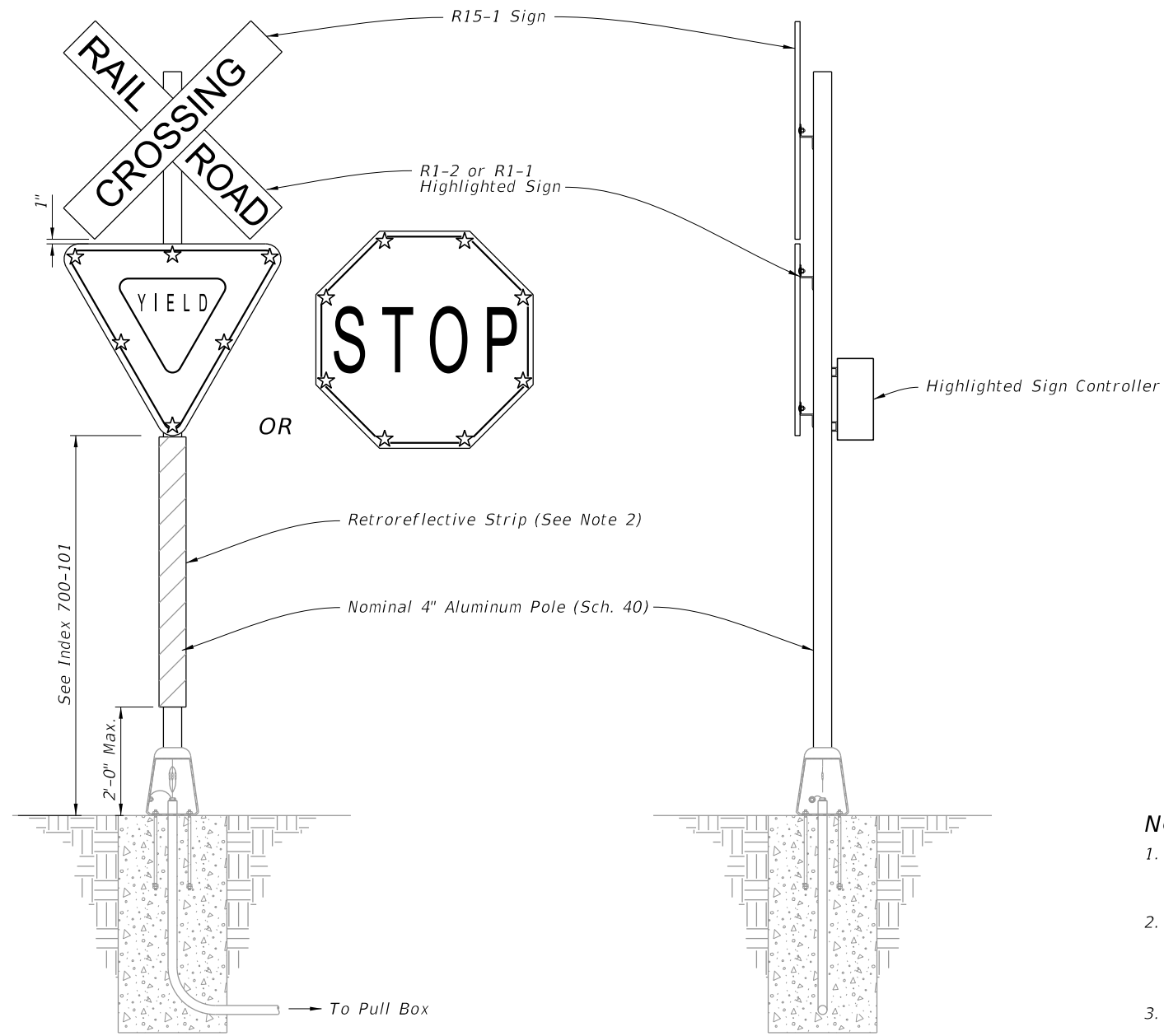

FRONT ELEVATION

SIDE ELEVATION

**NOTES:**

1. Type A11 Assembly (conventionally powered) is shown. Type B11 Assemblies (solar powered) similar.
2. Install red retroreflective strip on front and white retroreflective strip on back in accordance with Specification 700.
3. Foundation reinforcement not shown.

**ROADSIDE SIGN ASSEMBLY-11**

|                           |          |              |   |                                     |                  |                   |
|---------------------------|----------|--------------|---|-------------------------------------|------------------|-------------------|
| LAST REVISION<br>11/01/23 | REVISION | DESCRIPTION: | <br>FY 2024-25<br>STANDARD PLANS | ENHANCED HIGHWAY SIGNING ASSEMBLIES | INDEX<br>700-120 | SHEET<br>14 of 15 |
|---------------------------|----------|--------------|---|-------------------------------------|------------------|-------------------|

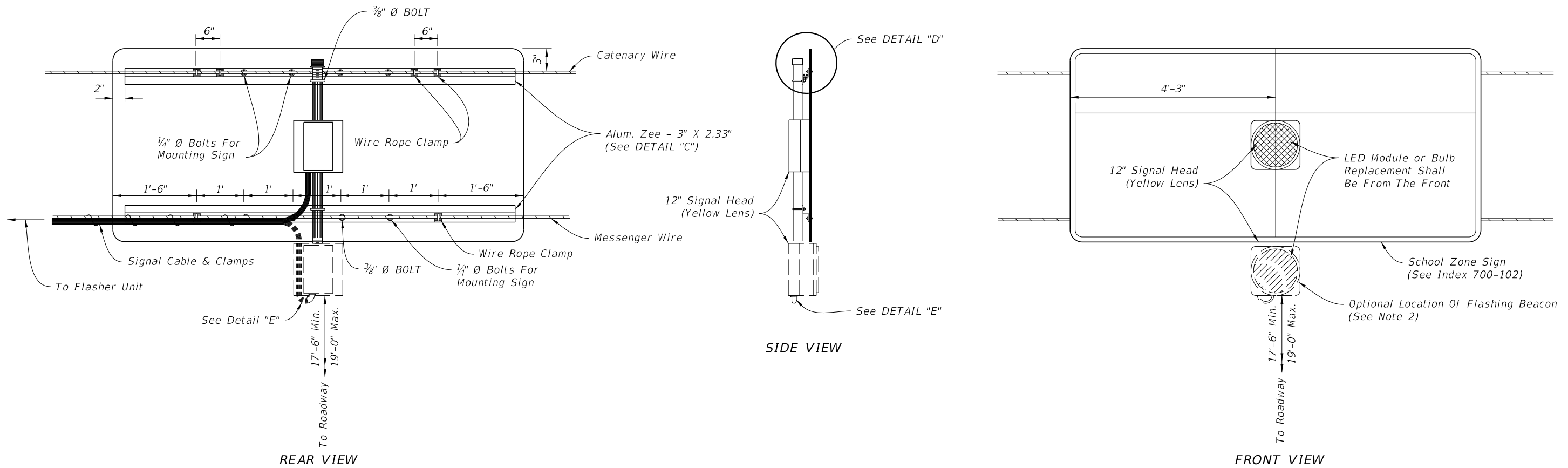

OVERHEAD SCHOOL SIGN ASSEMBLY

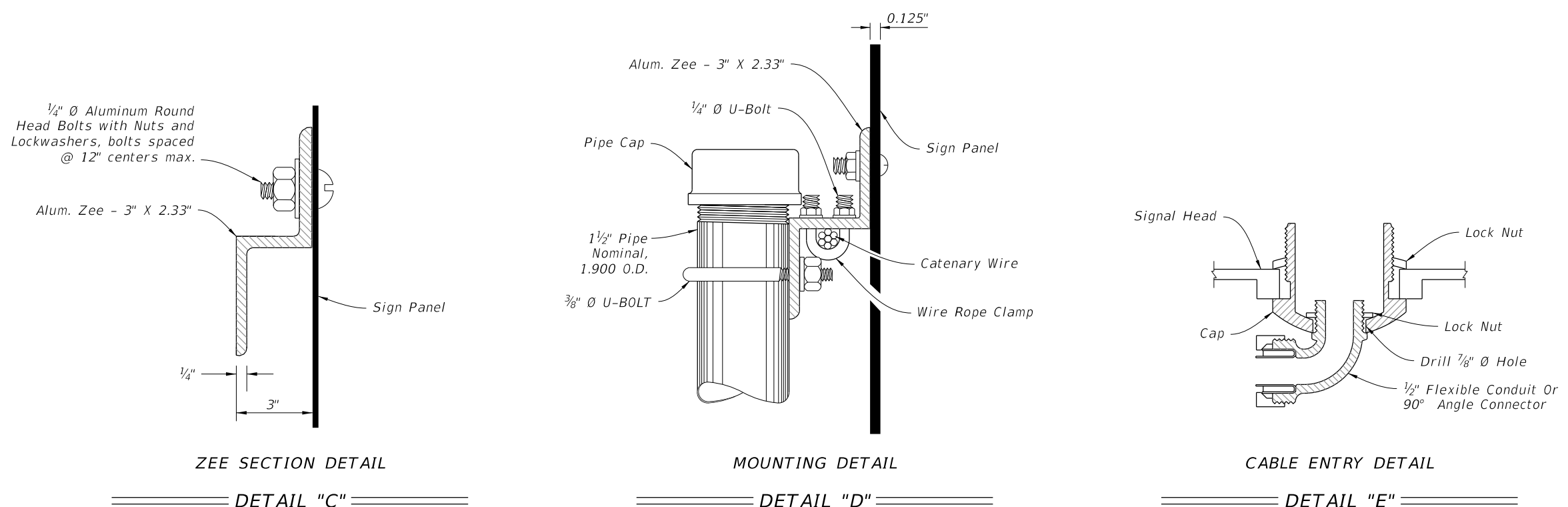

NOTES:

1. Flasher unit and cabinet to be placed on the strain pole supporting overhead sign assembly or on service pole. The flasher unit not to overhang private property or sidewalk.
2. Optional flashing beacon will be called for in the Plans. They may be placed within or below the panel, or face to the rear.

OVERHEAD SIGN ASSEMBLY

10/3/2023 3:19:12 PM

|                           |              |  |                              |                                     |         |          |
|---------------------------|--------------|--|------------------------------|-------------------------------------|---------|----------|
| LAST REVISION<br>11/01/23 | DESCRIPTION: |  | FY 2024-25<br>STANDARD PLANS | ENHANCED HIGHWAY SIGNING ASSEMBLIES | INDEX   | SHEET    |
|                           |              |  |                              |                                     | 700-120 | 15 of 15 |