

GENERAL NOTES:

1. Construct Perimeter Walls in accordance with Specification Section 534.
2. Choice of either Precast Option or Masonry Option is at the discretion of the Contractor. Contractor must also select the desired foundation type. Modifications to this Index is restricted to those required for geometric needs only.
3. Post spacing is measured from centerline to centerline of foundation element. For this Index, posts and foundation elements have been designed for 20 ft. spacings. Use post spacings less than 20 feet only at changes in horizontal alignment, wall terminations or to accommodate steep grades.
4. See "Perimeter Wall Data Tables" in the plans for project requirements.
5. Field verify the locations of all overhead and underground utilities shown in the Wall Control Drawings.

PRECAST OPTION NOTES:

6. WALL NOTES:
 - A. Walls may consist of either a single height panel or two stacked panels. Minimum panel height is 4'-3".
 - B. Only when reduced overhead clearance between posts prohibits installation of panels from the top, side-installed panels are allowed. After panel is centered between posts, grout between panel ends and posts.
7. CONCRETE AND GROUT:
 - A. Cast-in-Place and Precast Concrete: Class IV
 - B. Grout for Auger Cast Piling: Minimum 28 Day Strength = 5000 psi
 - C. Minimum Compressive Strength for Form Removal and Handling of Posts, Panels and Precast Spread Footings:
 - i. 2,500 psi for horizontally cast post, panels and precast spread footings.
 - ii. 2,000 psi for vertically cast panels or when tilt-up form tables are used for horizontally cast panels.
8. REINFORCING STEEL:
 - A. Concrete Cover: 1 1/2" unless otherwise noted.
 - B. In addition to the requirements of Specification Section 415, tie post and pile stirrups at the following locations as a minimum:
 - i. Post Stirrups - Tie at all four corner bars and at every third interior bar intersection.
 - ii. Pile Stirrups - Tie to the main vertical reinforcing at alternate intersections.
9. BEARING PADS:
 - A. Bearing Pads for Collar or Pedestal Bearing Points and between stacked panels may be either Plain or Fiber Reinforced Neoprene Pads, in accordance with Specification Section 932 for ancillary structures.
10. CASTING TOLERANCES:
 - A. Overall Height & Width: +/- 1/4"
 - B. Thickness: +/- 1/4"
 - C. Plane of side mold: +/- 1/16"
 - D. Openings: +/- 1/2"
 - E. Out of Square: 1/8" per 6 ft., but not more than 3/8" total along any side
 - F. Warping: 1/16" per foot distance to nearest corner
 - G. Bowing: 1/240 panel dimension
11. PILING:
 - A. Construct Auger Cast Piling in accordance with the Plans and Specification Section 455.

MASONRY OPTION NOTES:

12. WALL NOTES:
 - A. Inspect construction in accordance with the International Building Code (IBC) Section 17.
 - B. Construct masonry walls with 8x8x16 block using a running bond pattern and concave tooled joints.
 - C. Make all elevation changes (steps) in footing and top of wall using full height blocks. Make top of wall steps at pilasters exclusively. Footing steps may be made between pilasters as necessary to maintain minimum soil cover.

MASONRY OPTION NOTES (CONT.):

- D. Fully Grout all cells with horizontal or vertical reinforcing bars.
 - E. Use reinforcing bar positioners to maintain vertical and horizontal bar placement.
 - F. Fully grout first three courses of the wall.
 - G. Joint Reinforcement: Use W 1.7 (9mm) galvanized ladder reinforcing spaced at 16" vertically. Provide special accessories for corners, intersections, etc. Joint reinforcing shall be continuous except it shall not pass through vertical masonry control joints. Lap joint reinforcing a minimum of 6".
 - H. Construct expansion joints in the foundation at 90 foot maximum intervals, and directly below a wall control joint.
 - I. Dowel Load Transfer Devices will be ASTM A 36 smooth round bars hot-dip galvanized in accordance with Specification Section 962. Install Dowel Load Transfer Devices in accordance with Specification Section 350.
 - J. For spread footings, use a walk-behind compactor of at least 600 lbs. in weight. Obtain a minimum density of 95% of the maximum dry density as determined by FM 1 T-180. Perform soil density tests at 100 foot intervals.
 - K. Protect walls during construction from soil, grout or mortar stains. Clean wall as work progresses by dry brushing to remove mortar fins and smears before tooling joints.
 - L. Use soap and potable water to clean walls. If stain removal is necessary, use a cleaning method indicated in NCMA TEK 8-2A applicable to the type of stain on the exposed surface.
 - M. During construction, cover tops of walls, with waterproof sheeting at the end of each day's work, or when construction is not in progress. Extend sheeting a minimum of 2 feet down each side and secure in place.
 - N. Comply with Hot Weather Requirements in ACI 530.1.
13. MATERIALS:
 - A. Concrete Masonry Units (CMU): Provide normal weight blocks.
 - B. Cast-In-Place Concrete: Class II for slightly to moderate aggressive environments or Class IV for extremely aggressive environments.
 - C. Mortar: Type S meeting requirements of ASTM C1329
 - D. Grout: Type S; coarse grout.
 - E. Aggregate for Grout: Meet the requirements of ASTM C404 or Specification Section 901 size 8 or 89.
 14. STORAGE OF MATERIALS:
 - A. Store CMU's on elevated platforms in a dry location or under cover. If units become wet, do not install until they are dry.
 - B. Store cementitious materials on elevated platforms, under cover, and in a dry location. Do not use cementitious materials that have become damp or exceeded the manufacturers shelf life.
 - C. Store masonry accessories and reinforcing to prevent corrosion and accumulation of dirt and oil.

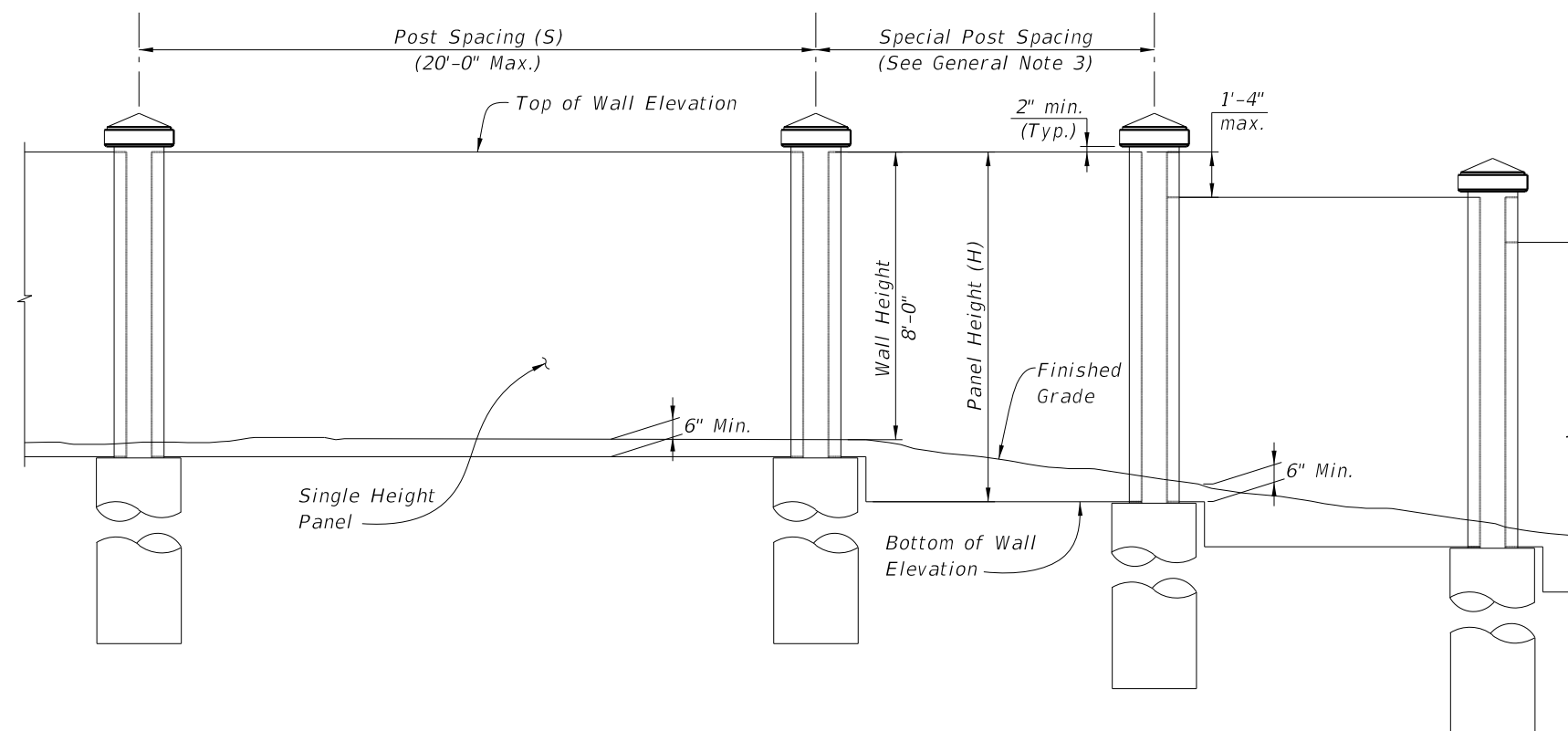

GENERAL WALL ELEVATION
(Precast Option with Single Height Panel Shown, Others Similar)

GENERAL NOTES

10/3/2023 1:29:40 PM

LAST REVISION 11/01/17	DESCRIPTION:		FY 2024-25 STANDARD PLANS	PERIMETER WALLS	INDEX 534-250	SHEET 1 of 10
---------------------------	--------------	--	------------------------------	-----------------	------------------	------------------

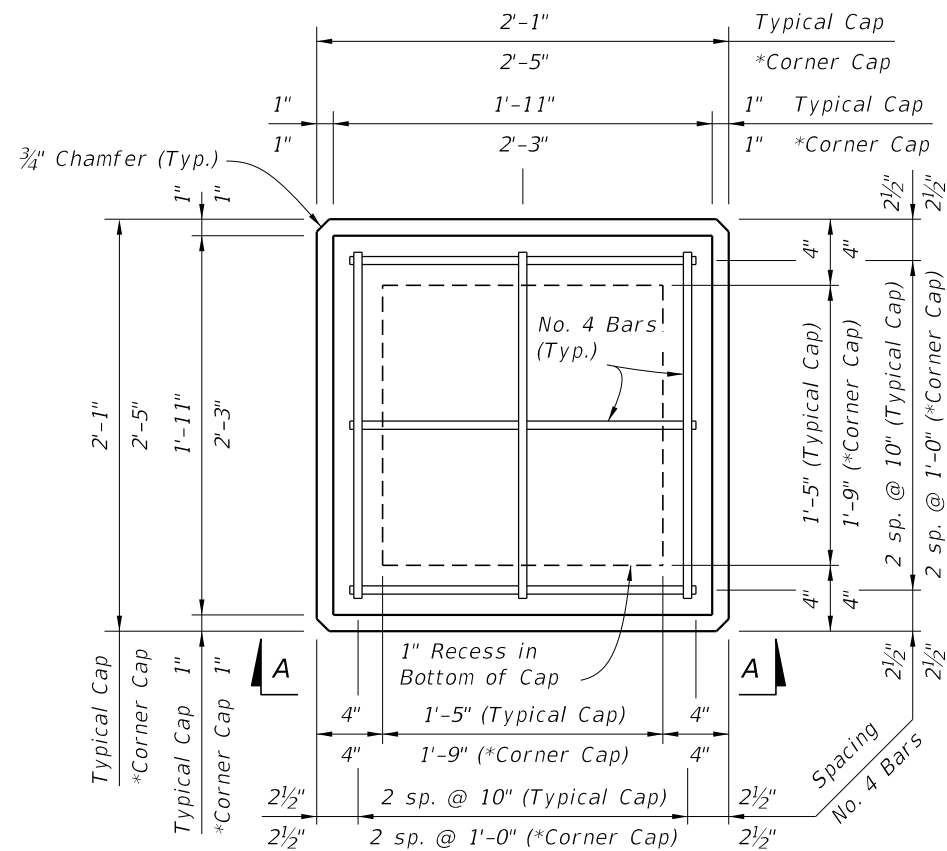

PLAN VIEW
(Type "A" Cap Shown, Type "B" & "C" Caps Similar)

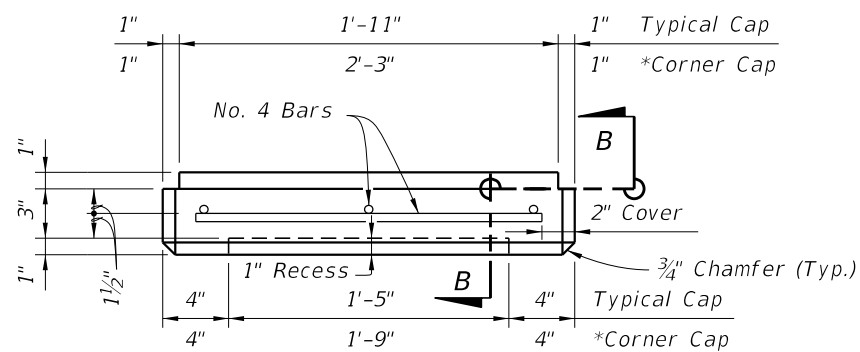

VIEW A-A
(Type "A" Cap Shown, Type "B" & "C" Caps Similar)

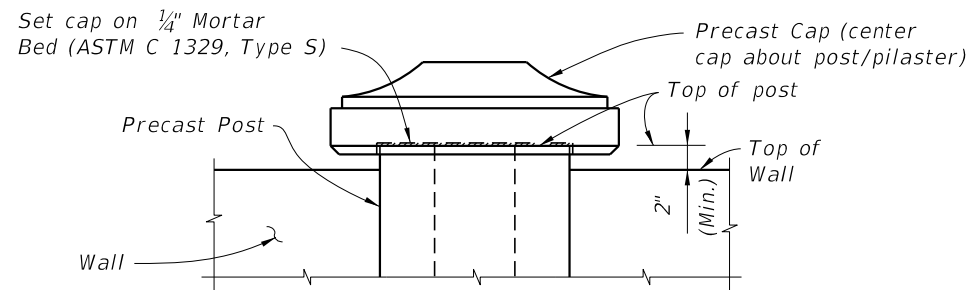

CAP PLACEMENT DETAIL
(Type "B" Post Cap with Precast Option Shown)

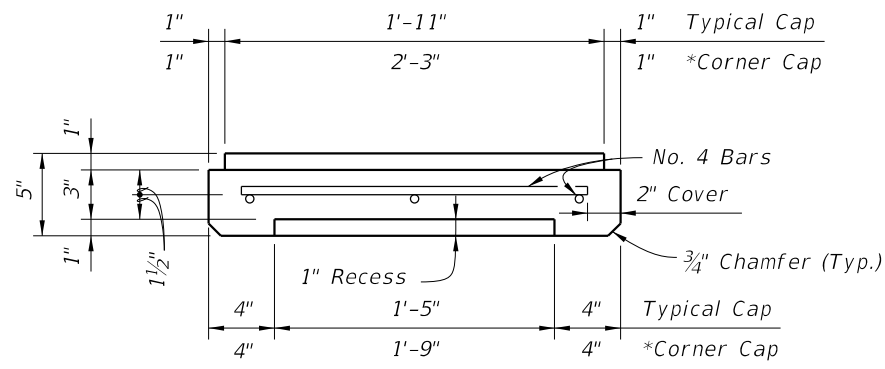

SECTION B-B

TYPE "A" CAP DETAILS

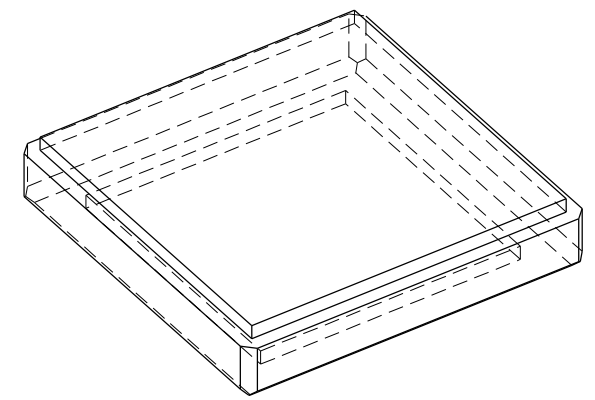

PICTORIAL VIEW

*Precast Option only

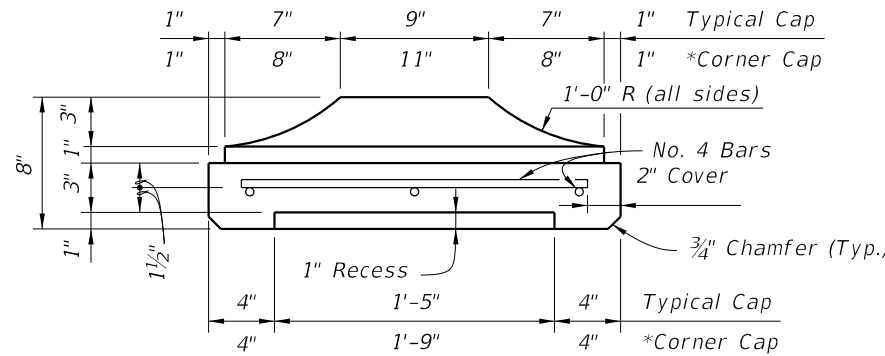

SECTION B-B

TYPE "B" CAP DETAILS

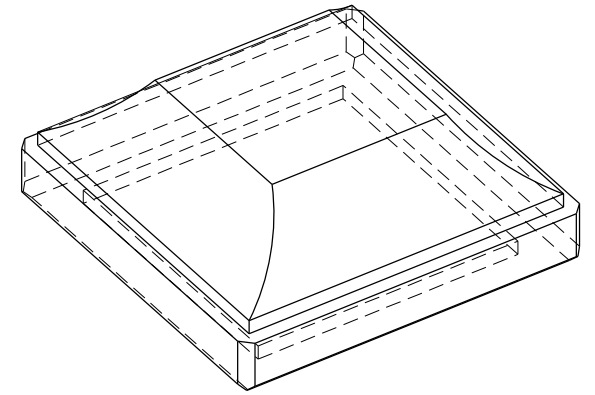

PICTORIAL VIEW

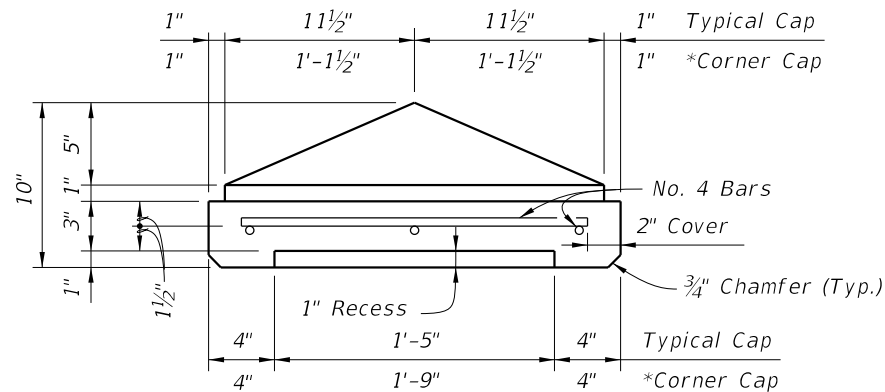

SECTION B-B

TYPE "C" CAP DETAILS

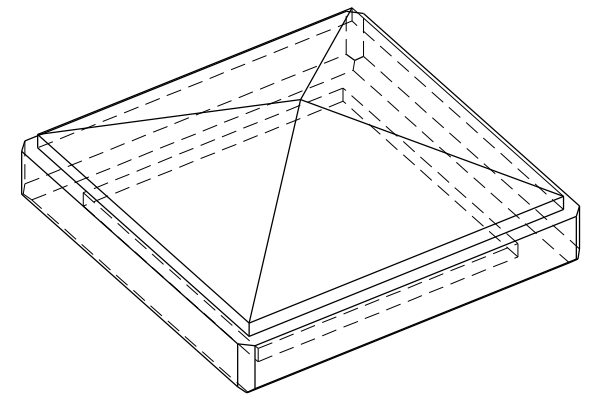

PICTORIAL VIEW

10/3/2023 1:29:46 PM

LAST REVISION 11/01/14	DESCRIPTION:
---------------------------	--------------



FY 2024-25
STANDARD PLANS

PERIMETER WALLS

POST CAP DETAILS

INDEX 534-250	SHEET 2 of 10
------------------	------------------

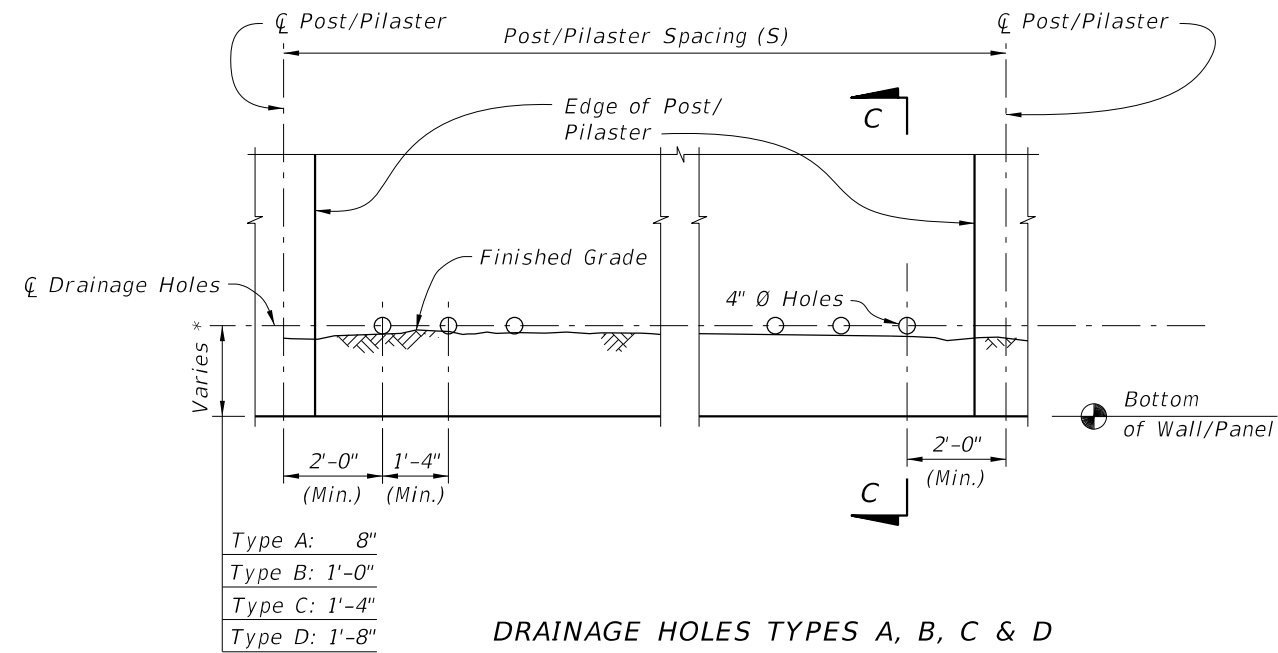

Type A:	8"
Type B:	1'-0"
Type C:	1'-4"
Type D:	1'-8"

DRAINAGE HOLES TYPES A, B, C & D

* Hole Types A, B, C, & D refer to distance from bottom of panel/wall to center of the pipe.

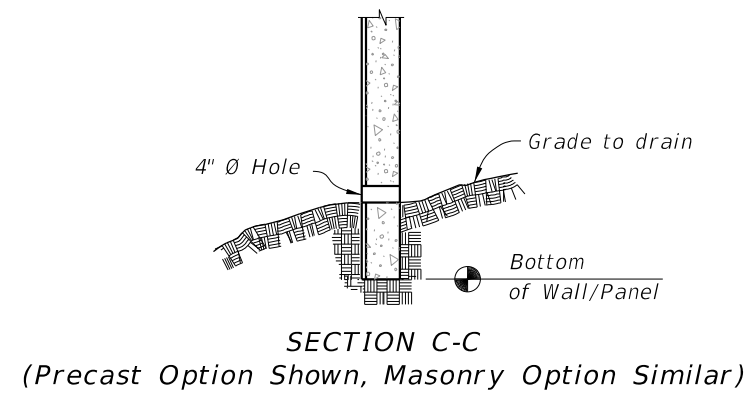

NOTES:

1. Drainage holes may be formed with 4" NPS PVC pipe that may remain in place.
2. See Wall Control drawings for number, Type and location/spacing of drainage holes.

10/3/2023 1:29:53 PM

LAST REVISION 11/01/14	REVISION	DESCRIPTION:	 FY 2024-25 STANDARD PLANS	PERIMETER WALLS	INDEX	SHEET
					534-250	3 of 10

DRAINAGE DETAILS

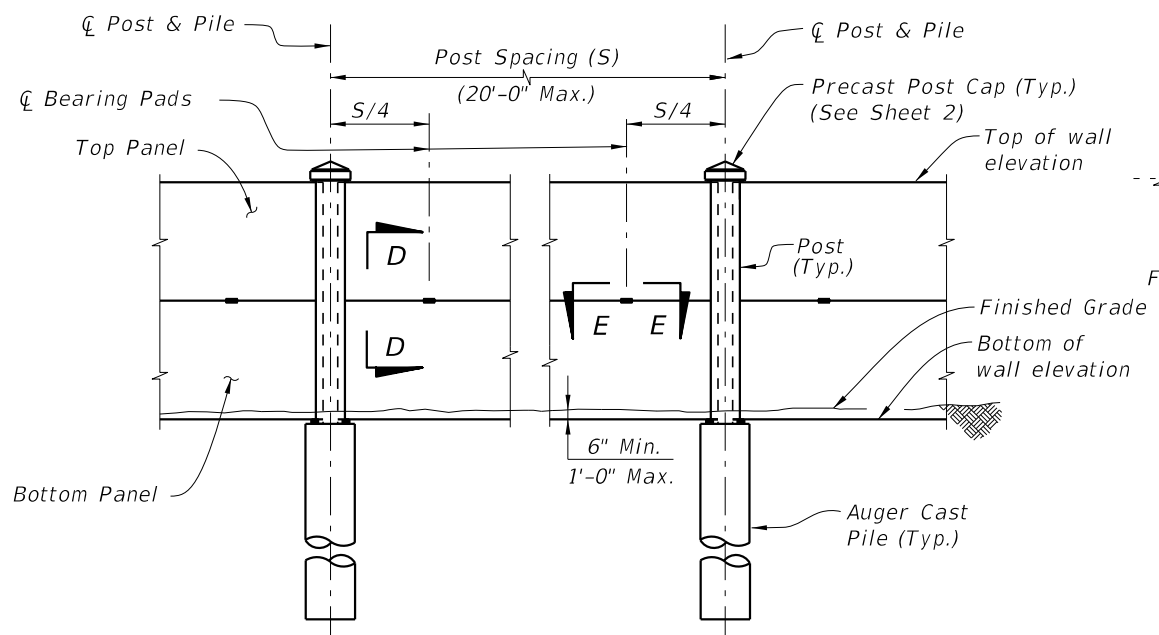

TYPICAL ELEVATION
(Front Face Shown, Textured Finish not Shown for Clarity)

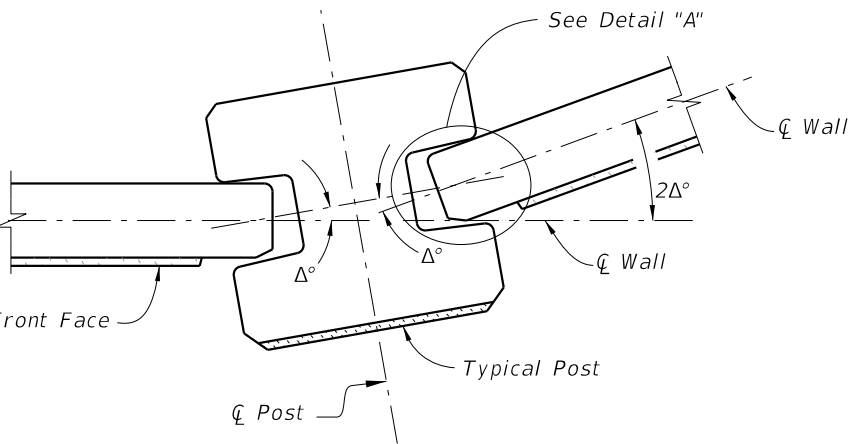

PIVOTING JOINT DETAILS

NOTE: Shop Drawings shall include specific pivoting point details of panel ends at locations where the deflection angle ($2\Delta^\circ$) between panels exceeds 20° .

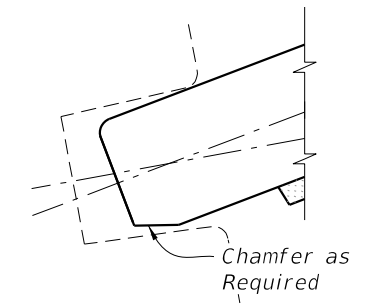

DETAIL "A"
(Back Face Chamfer Shown, Front Face Chamfer Similar)

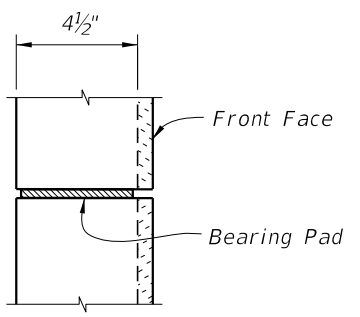

SECTION D-D

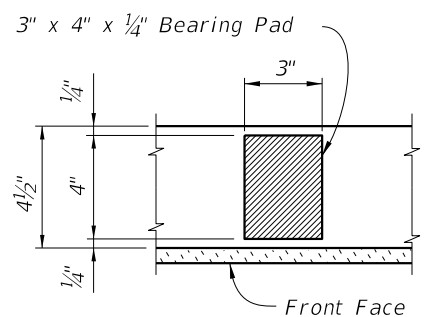

SECTION E-E

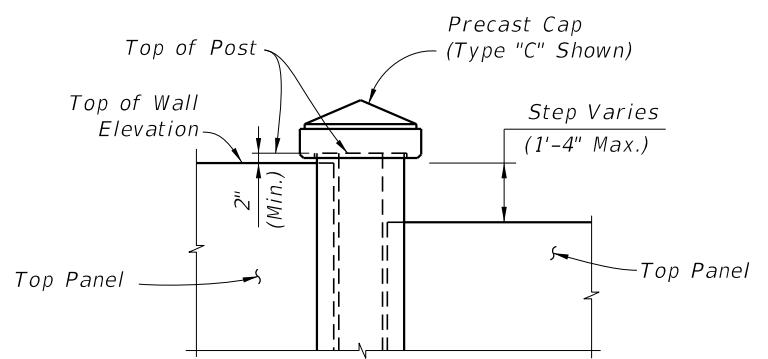

ELEVATION STEP AT TOP OF WALL
(Precast Panel Cap not Shown)

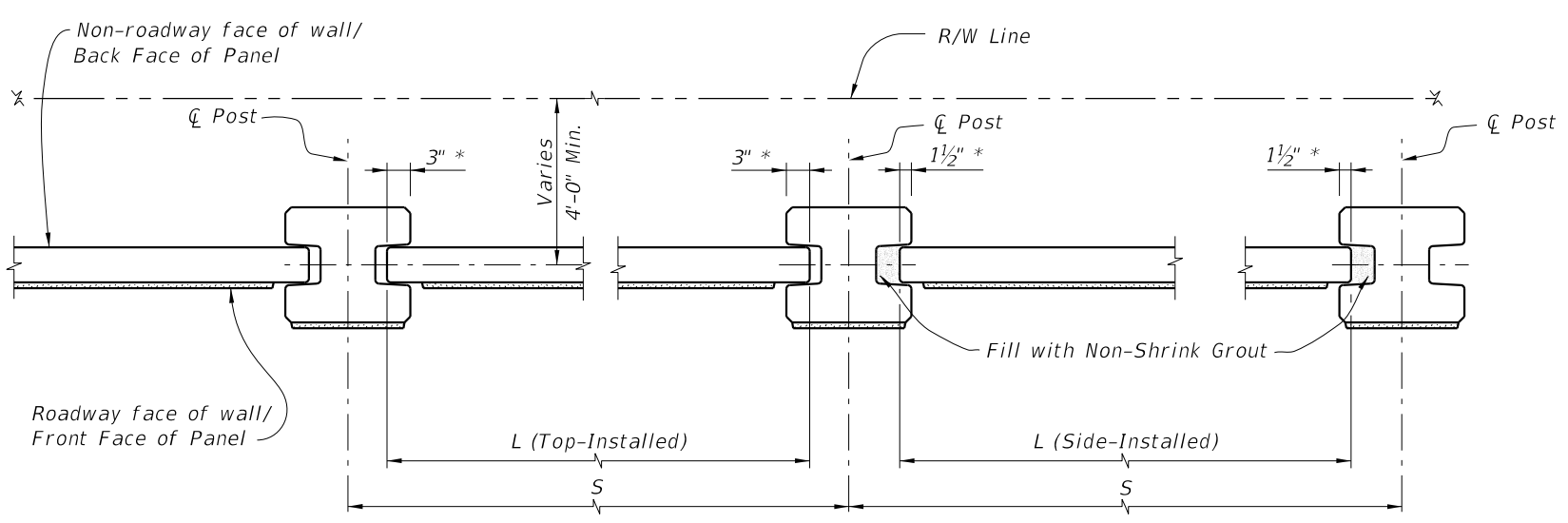

TYPICAL PLAN

* Nominal embedment (not including tolerances)

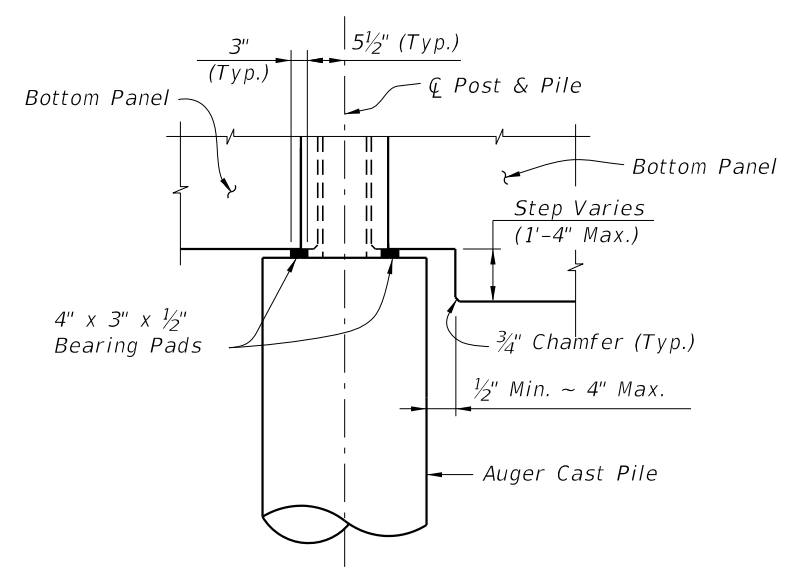

ELEVATION STEP AT BOTTOM OF WALL

PRECAST OPTION - TYPICAL DETAILS

10/3/2023 1:29:59 PM

LAST REVISION 11/01/17	REVISION	DESCRIPTION:	FDOT	FY 2024-25 STANDARD PLANS	PERIMETER WALLS	INDEX 534-250	SHEET 4 of 10
---------------------------	----------	--------------	------	------------------------------	-----------------	------------------	------------------

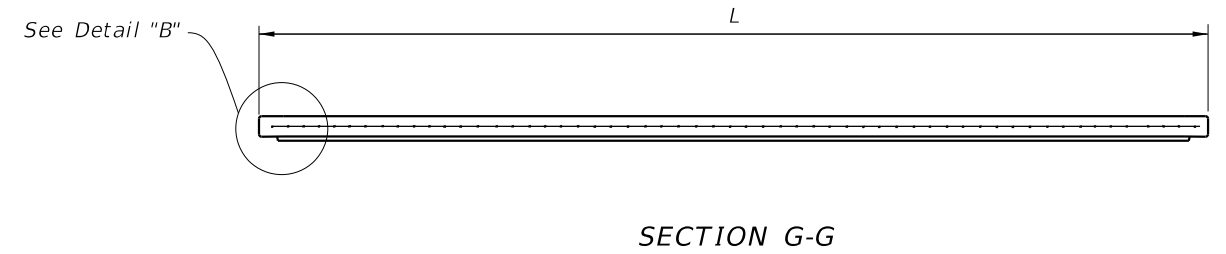
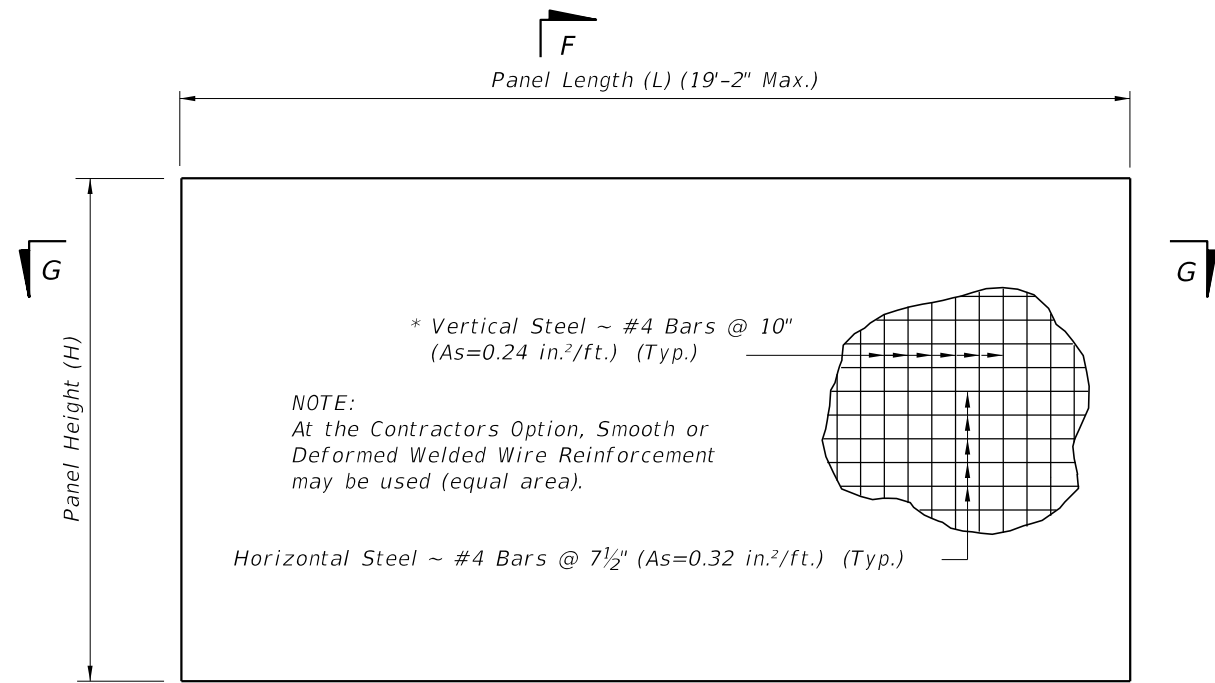

TYPICAL PANEL ELEVATION

* In lieu of utilizing the standard pick up points below, panels may be cast vertically or cast horizontally then tilted upright using tilt-tables prior to lifting from form. In this case, pick points must be placed in the top of panels only and transported maintaining the vertical orientation. If these criteria are met, the vertical steel may be reduced to #4 Bars @ 1'-3" (As=0.16 in.²/ft.).

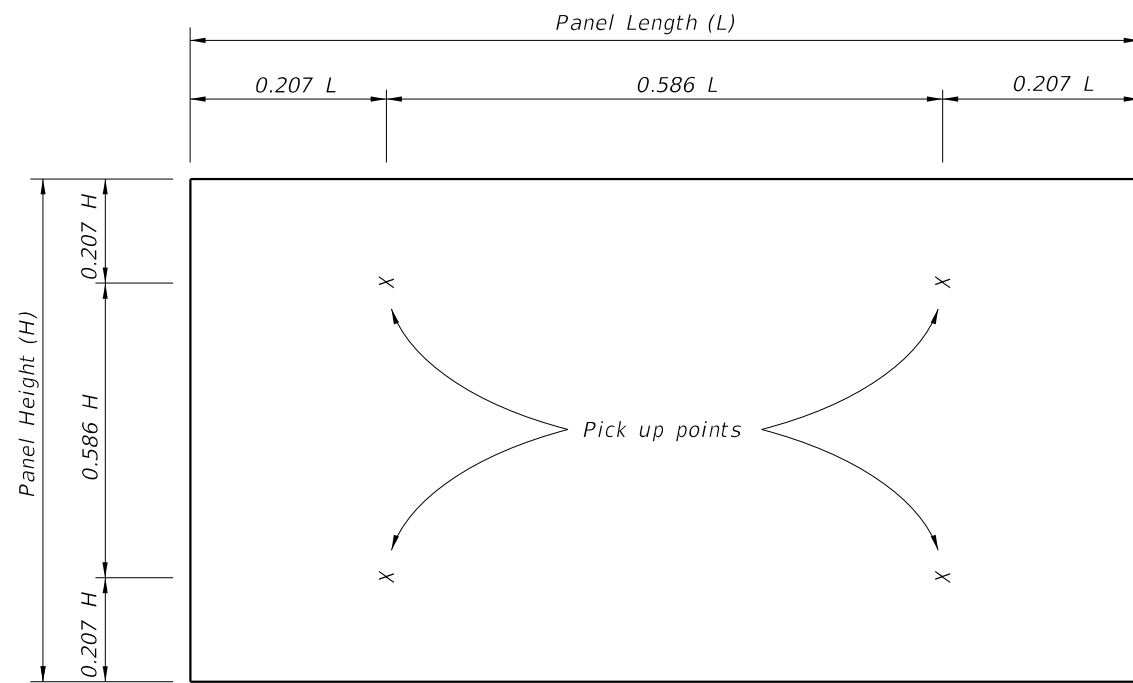

STANDARD PICK UP POINTS FOR PANELS
(Panels shall be rotated about long axis only)

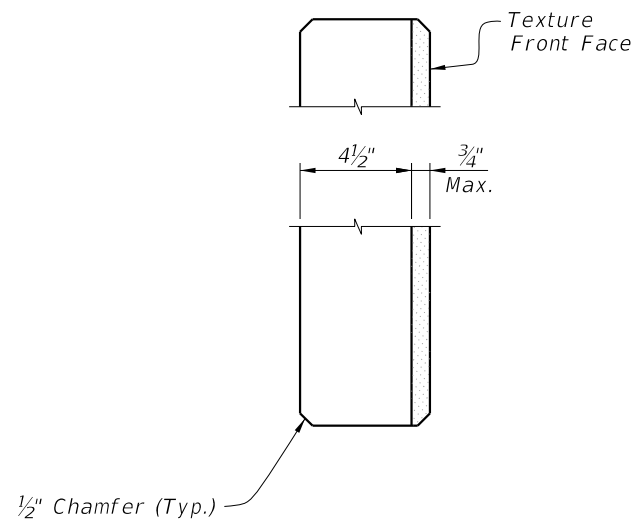

SECTION F-F

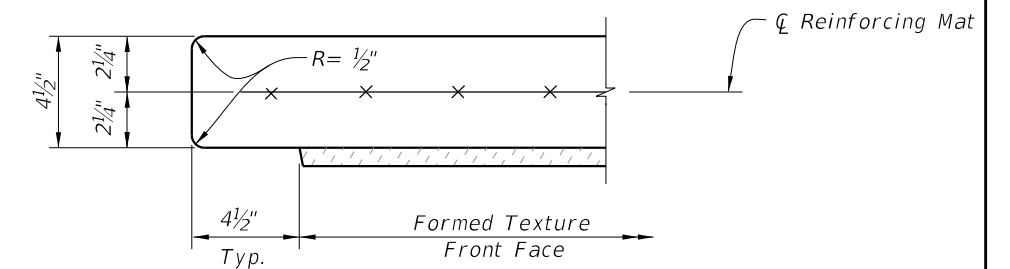

DETAIL "B" - TOP-INSTALLED
(Typ. Both Ends)

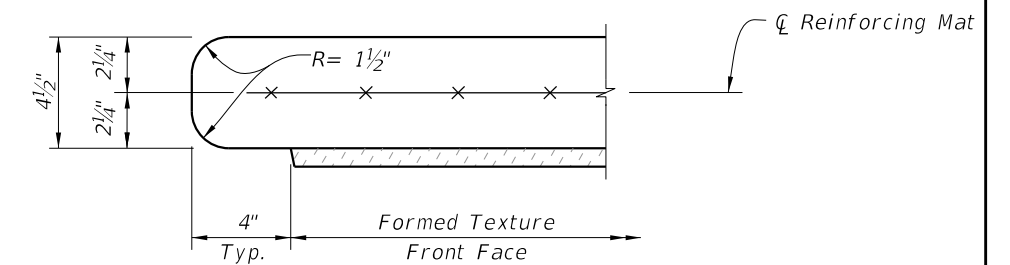

DETAIL "B" - SIDE-INSTALLED
(Typ. Both Ends)

PRECAST OPTION - TYPICAL PANEL DETAILS

10/3/2023 1:30:06 PM

LAST REVISION 11/01/14	DESCRIPTION:
---------------------------	--------------



FY 2024-25
STANDARD PLANS

PERIMETER WALLS

INDEX
534-250

SHEET
5 of 10

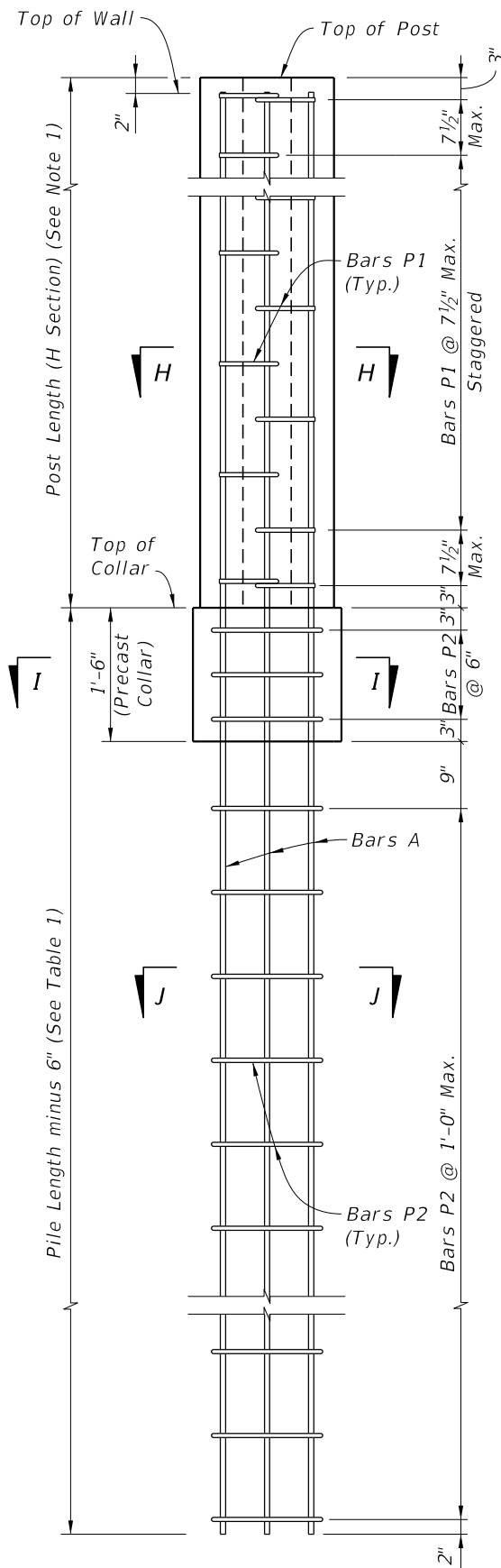

TYPICAL POST

STANDARD POST REINFORCEMENT

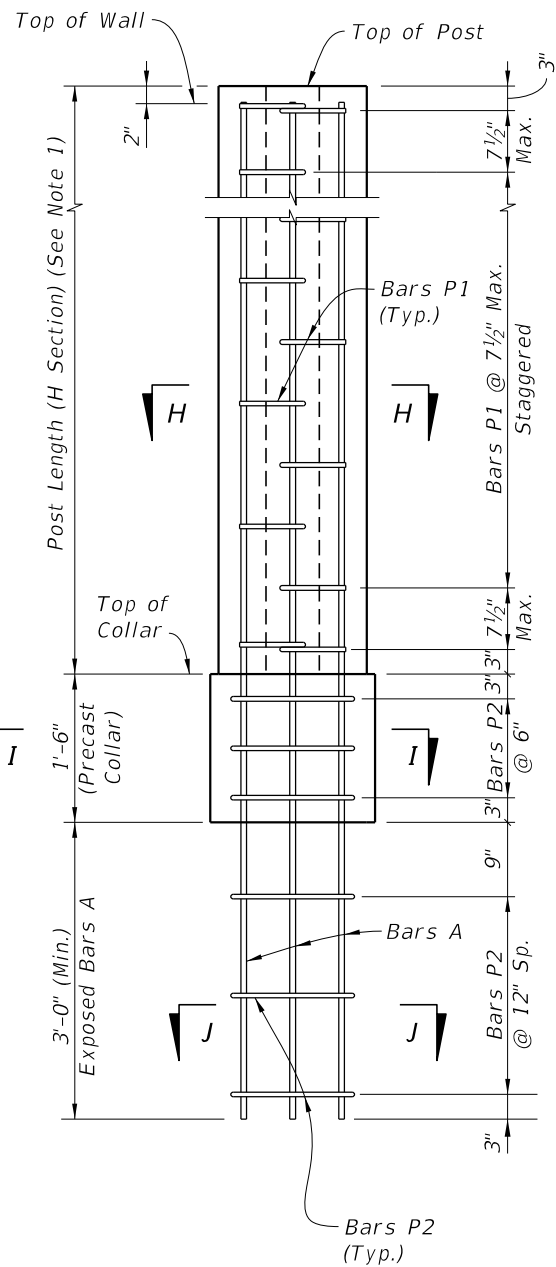

LOW CLEARANCE OPTION

NOTES:
1. See Shop Drawing for Post Lengths.

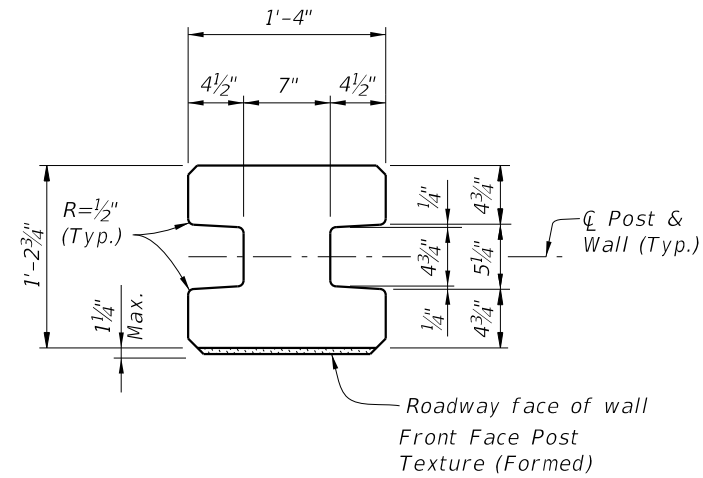

TYPICAL POST SECTION (H Section)

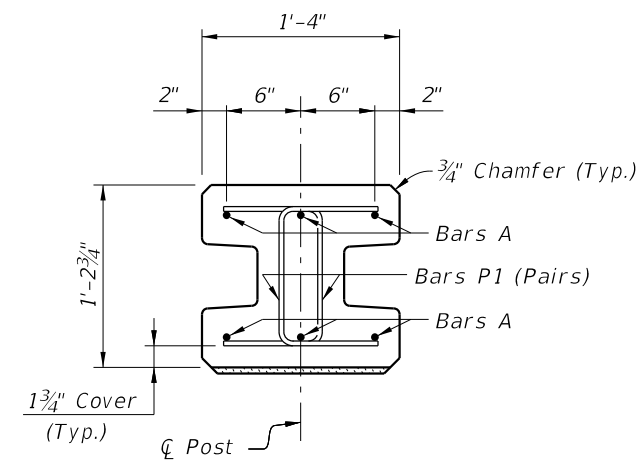

SECTION H-H (H Section - Above Collar)

Wind Speed (MPH)	Pile Length	Bars A	Bars P1 thru P6	Bars S1
130	12'-0"	#5	#3	#4
150	13'-6"	#5	#3	#4
170	15'-0"	#6	#3	#4

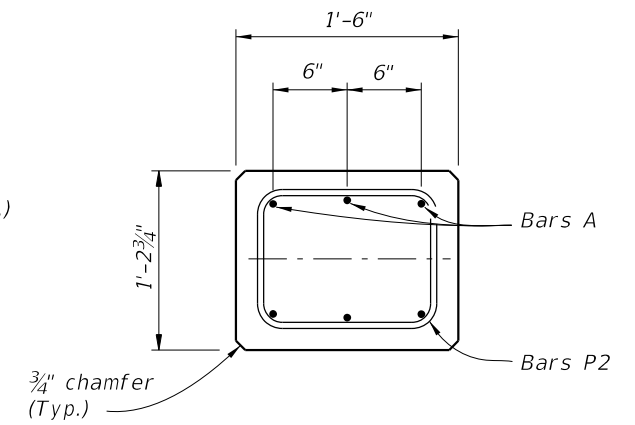

SECTION I-I Precast Collar

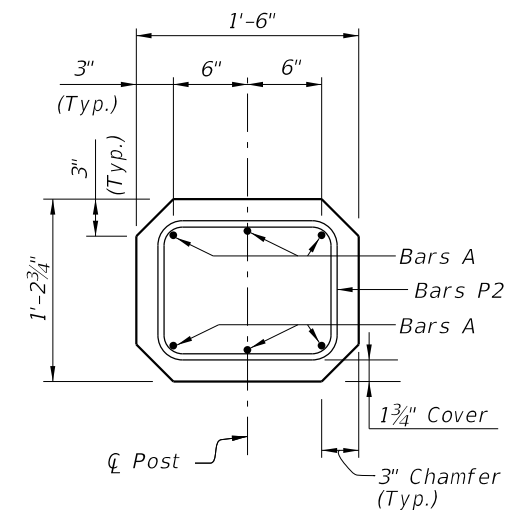

SECTION I-I (for Low Clearance Option)

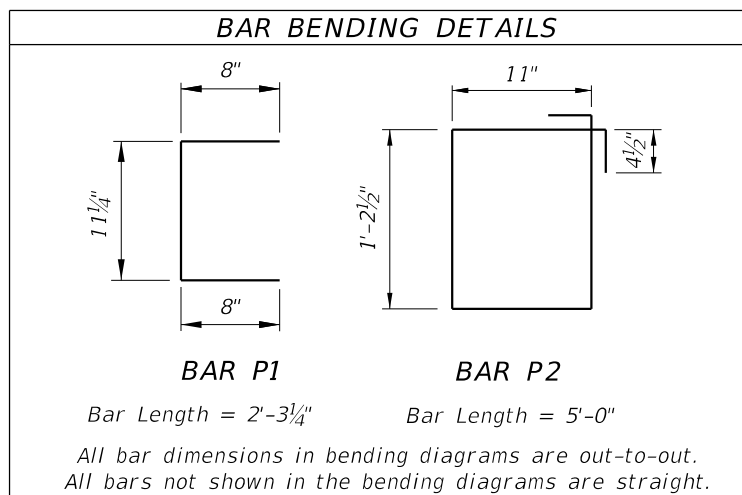

Bar Length = 2'-3 1/4" Bar Length = 5'-0"
All bar dimensions in bending diagrams are out-to-out.
All bars not shown in the bending diagrams are straight.

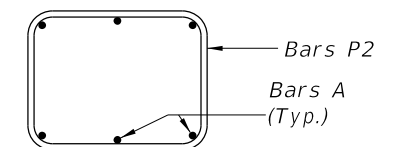

SECTION J-J

PRECAST OPTION - STANDARD POST DETAILS

10/3/2023 1:30:12 PM

LAST REVISION	DESCRIPTION:
11/01/17	



FY 2024-25
STANDARD PLANS

PERIMETER WALLS

INDEX
534-250

SHEET
6 of 10

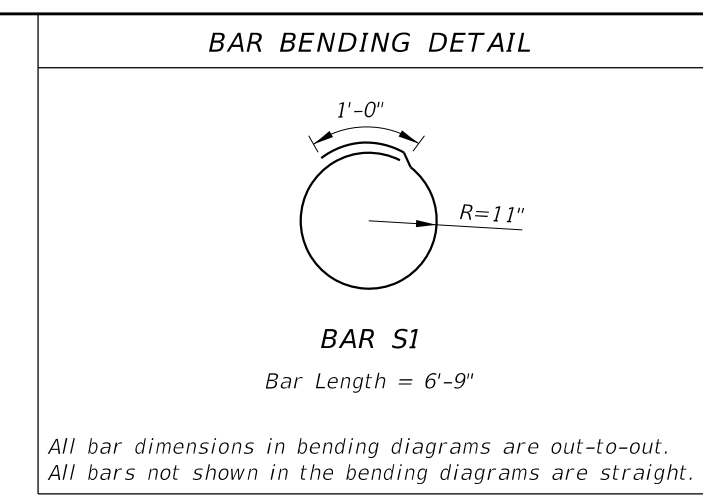
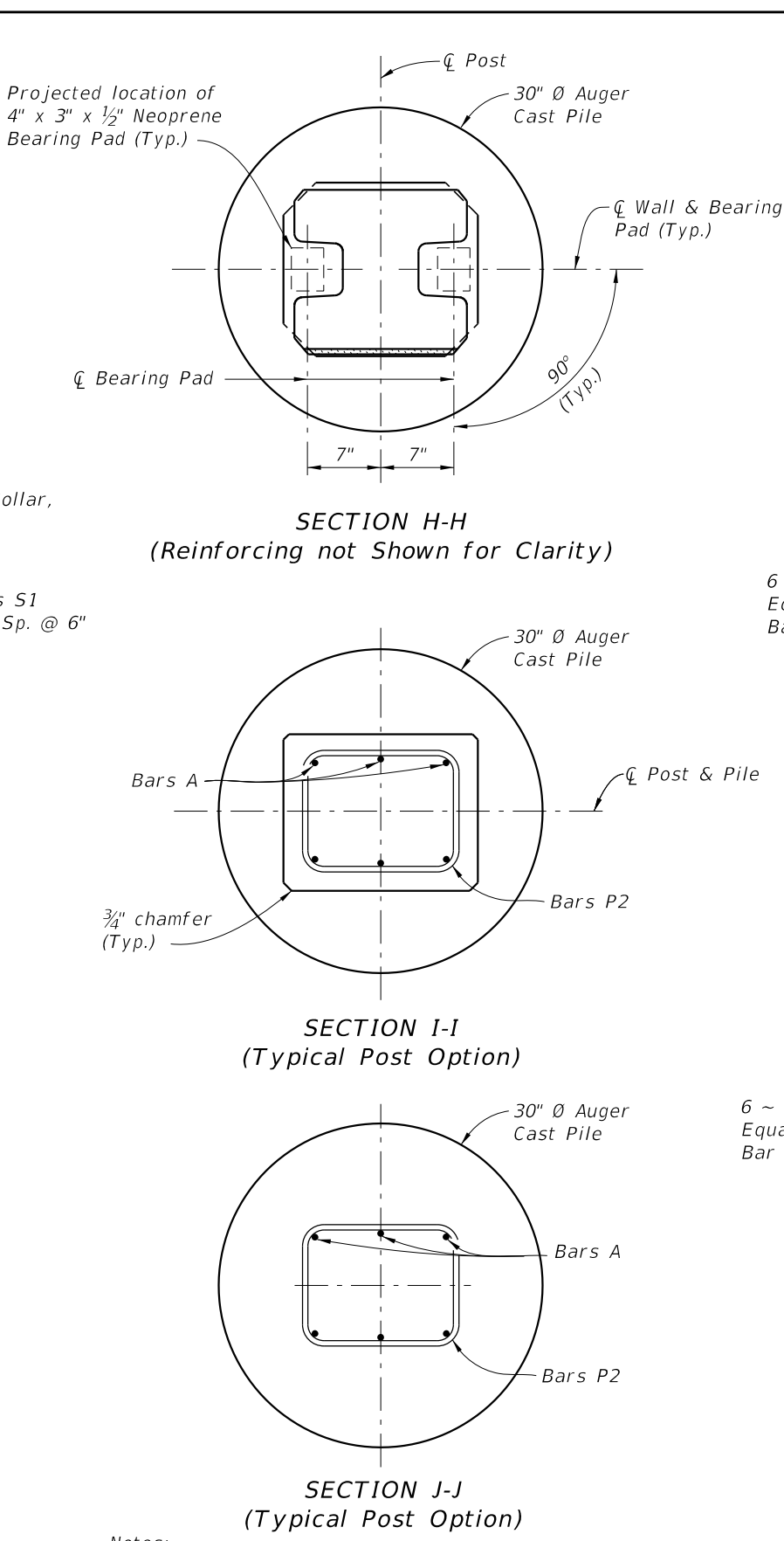
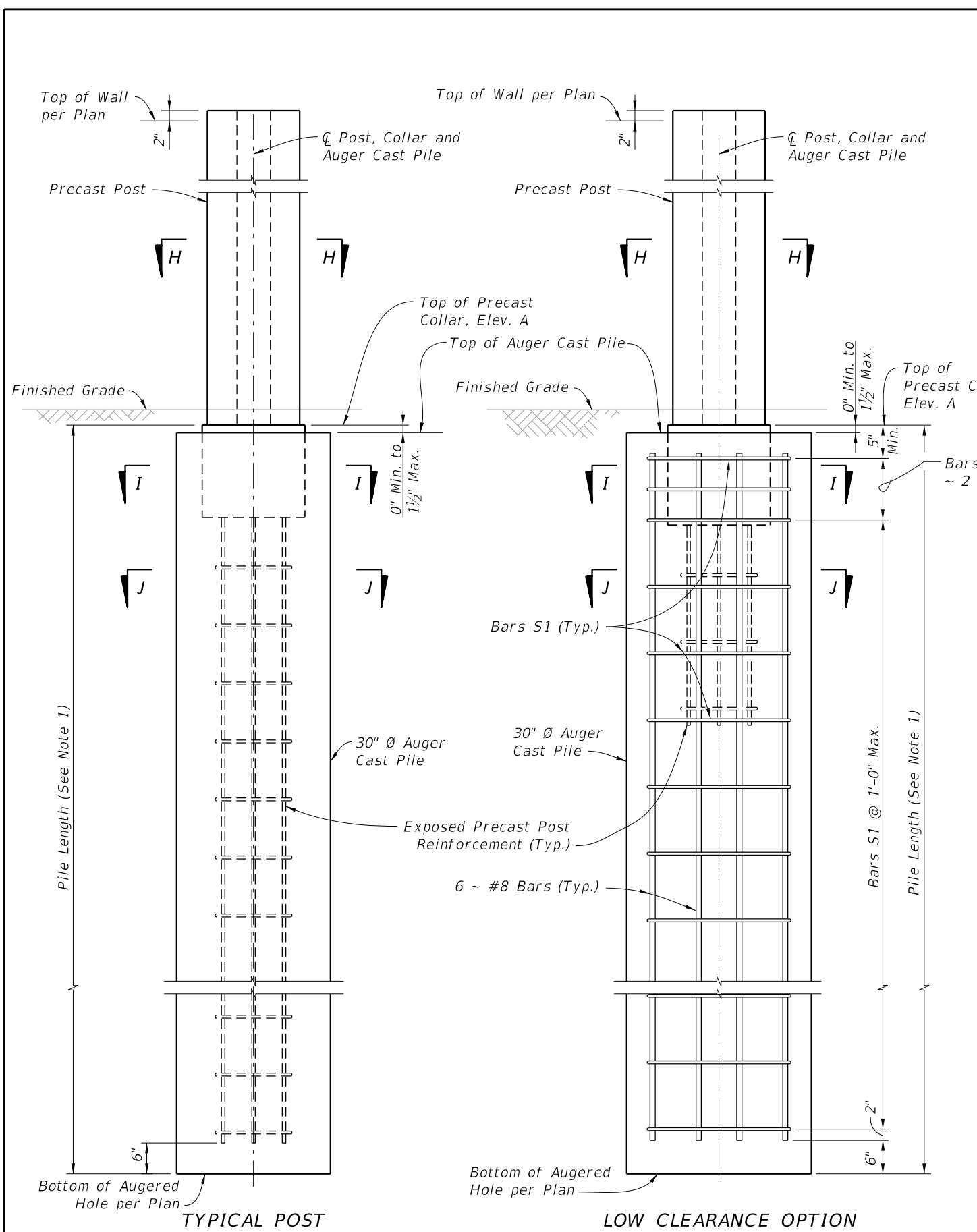

- Notes:
1. For Reinforcing Steel Sizes and Pile Lengths, see Table 1, Sheet 6.
 2. For Corner Posts, see Sheet 8.
 3. For Typical Post Section Dimensions, see Sheet 6.

STANDARD POST PLACEMENT IN AUGER CAST PILE
(Standard Post Shown, 45° and 90° Corner Posts Similar)

PRECAST OPTION - POST PLACEMENT & PILE REINFORCING STEEL DETAILS

10/3/2023 1:30:19 PM

LAST REVISION 11/01/16	DESCRIPTION:	FY 2024-25 STANDARD PLANS	PERIMETER WALLS	INDEX 534-250	SHEET 7 of 10
---------------------------	--------------	------------------------------	-----------------	------------------	------------------

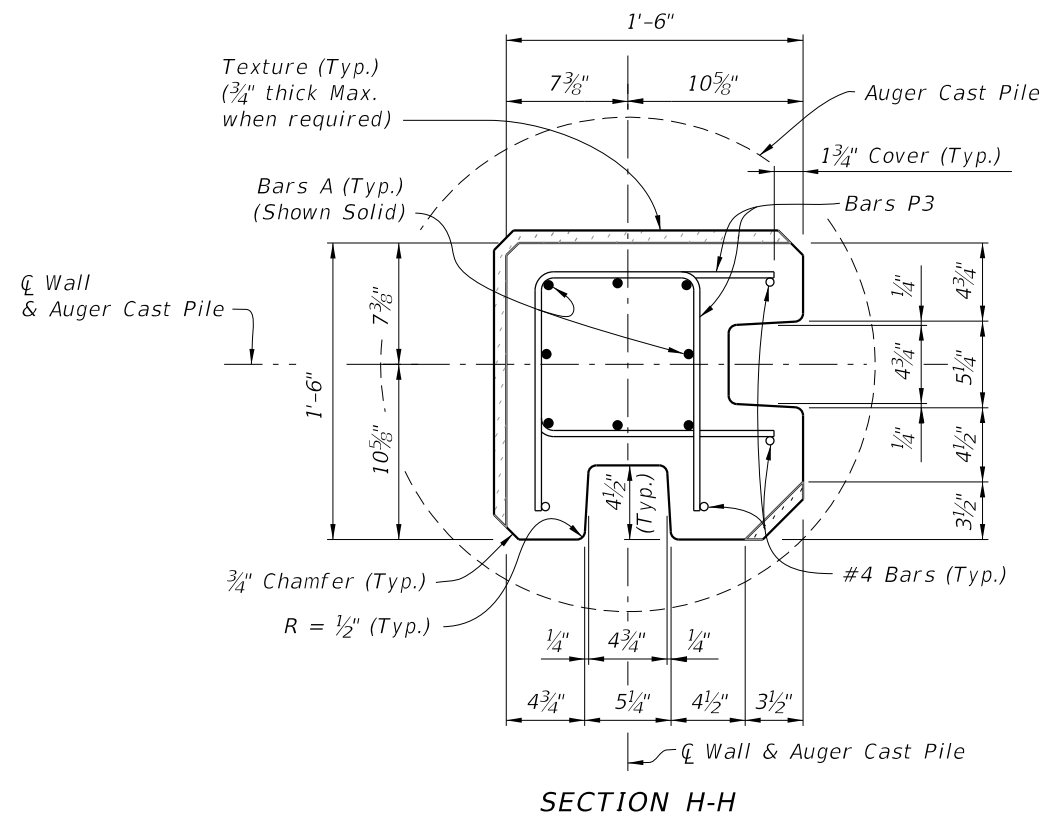

SECTION H-H

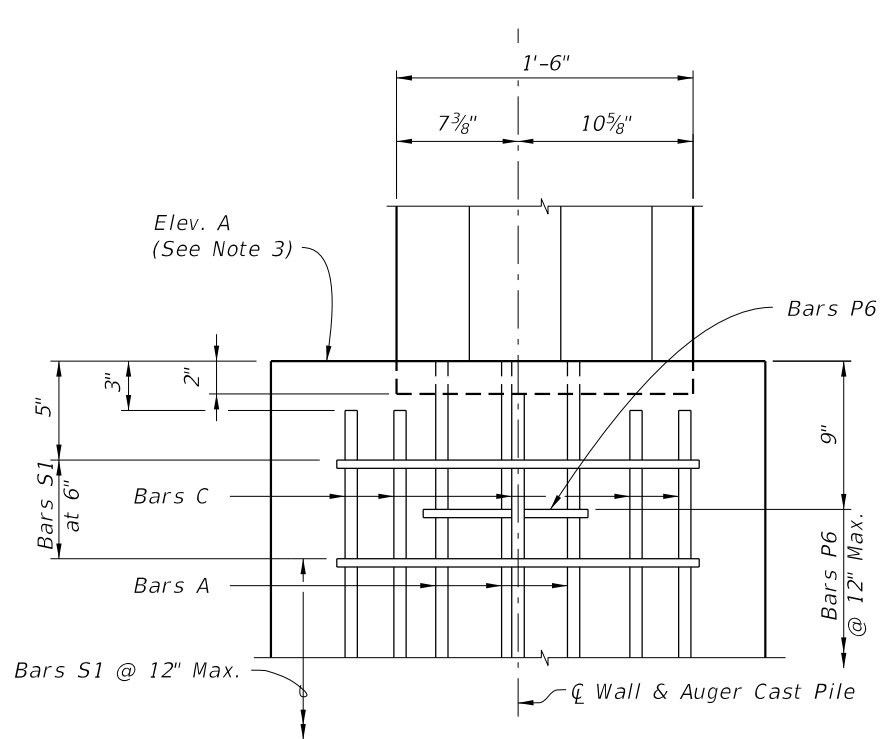

ELEVATION VIEW
(Low Clearance Shown)

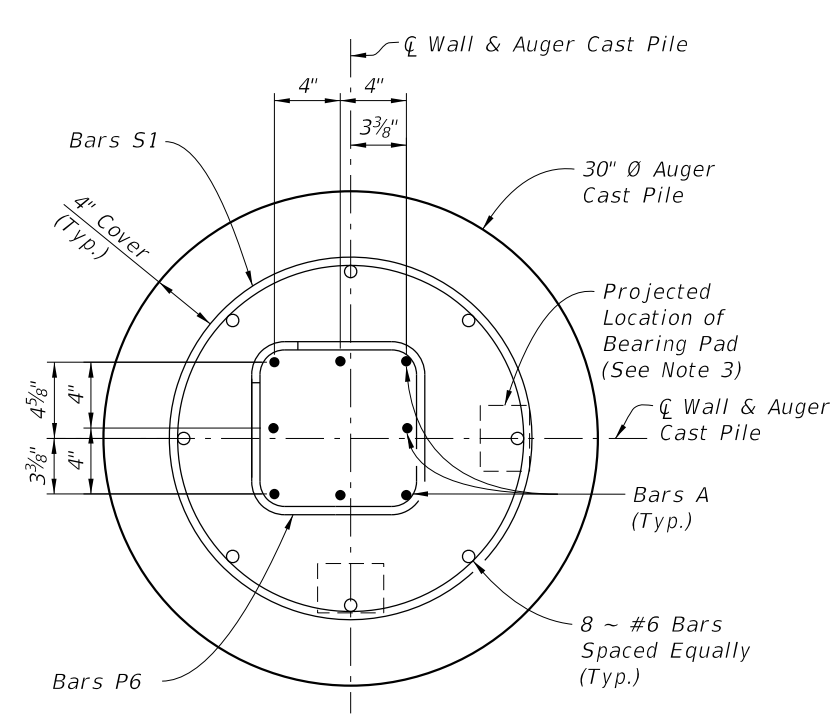

SECTION I-I
(See Note 3)

SPECIAL POST FOR 90° CORNERS

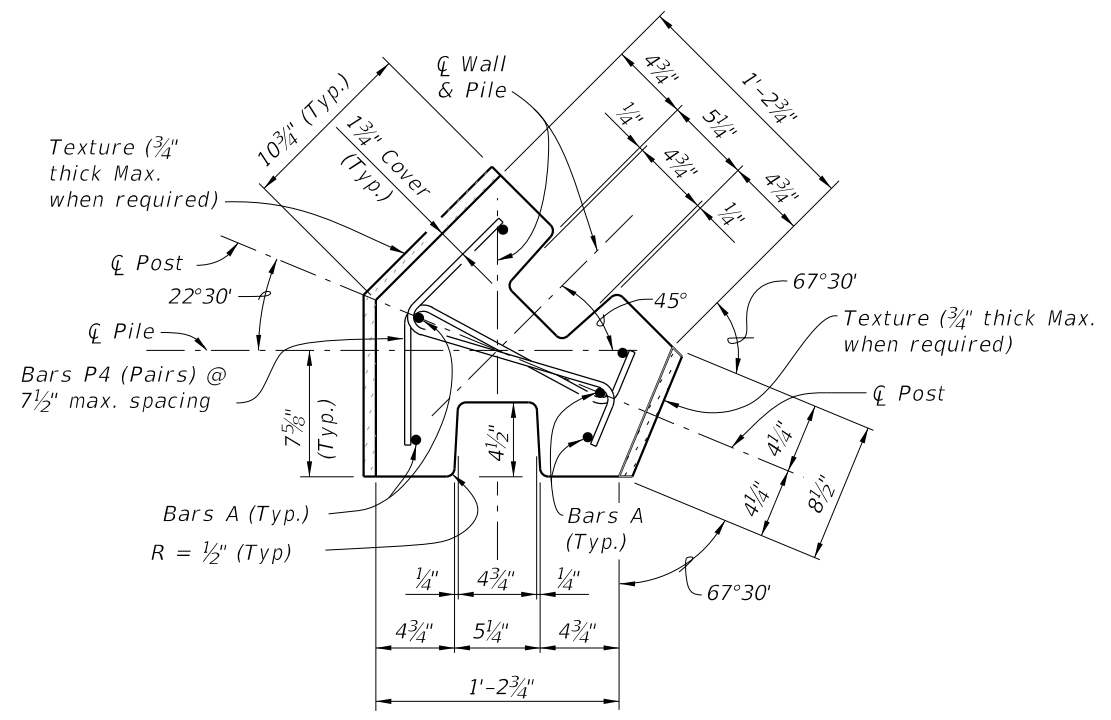

SECTION H-H

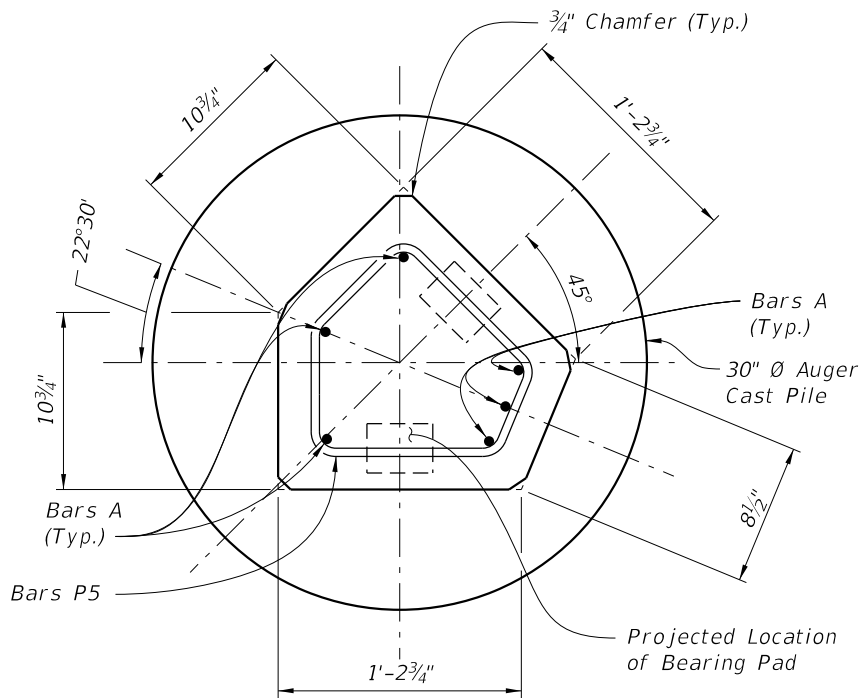

SECTION I-I
(Precast Collar)

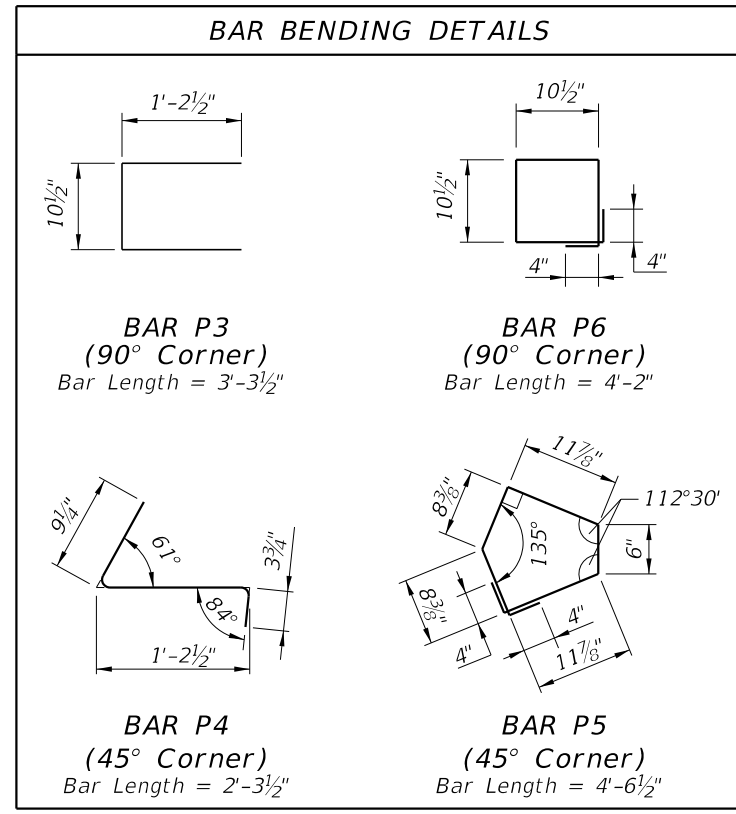

All bar dimensions in bending diagrams are out-to-out.
All bars not shown in the bending diagrams are straight.

SPECIAL POSTS FOR 45° CORNERS

- NOTES:
1. For Reinforcing Steel Sizes, and Foundation Dimensions, see Table 1 Sheet 6.
 2. For location of Section H-H and I-I, see Sheet 6.
 3. The Bearing area beneath Neoprene Pads is formed by top of Auger Cast Pile Grout.

PRECAST OPTION - SPECIAL CORNER POSTS

10/3/2023 1:30:25 PM

LAST REVISION 11/01/17	DESCRIPTION:		FY 2024-25 STANDARD PLANS	PERIMETER WALLS	INDEX	SHEET
			534-250		8 of 10	

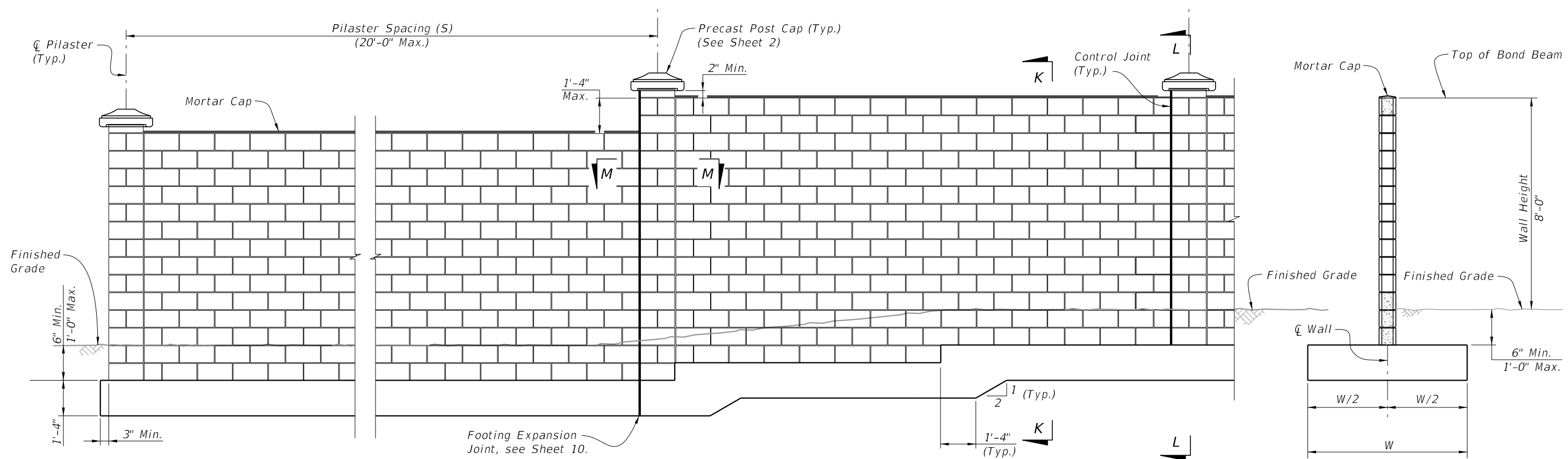

TYPICAL ELEVATION
(T-Footing Shown, Trench Footing Similar)

SECTION K-K
(Shown at Cell Without Vertical Reinforcing)

Wind Speed Category	Masonry Walls (8x8x16)		Foundations		
	Bars V1	SV Spacing	Bars F1 & F2	T-Footing Width (W)	Trench Footing Depth (D)
130	#5	2'-8"	#5	4'-4"	5'-6"
150	#5	2'-0"	#5	5'-0"	6'-4"
170	#5	1'-4"	#5	6'-0"	7'-0"

BAR BENDING DETAIL

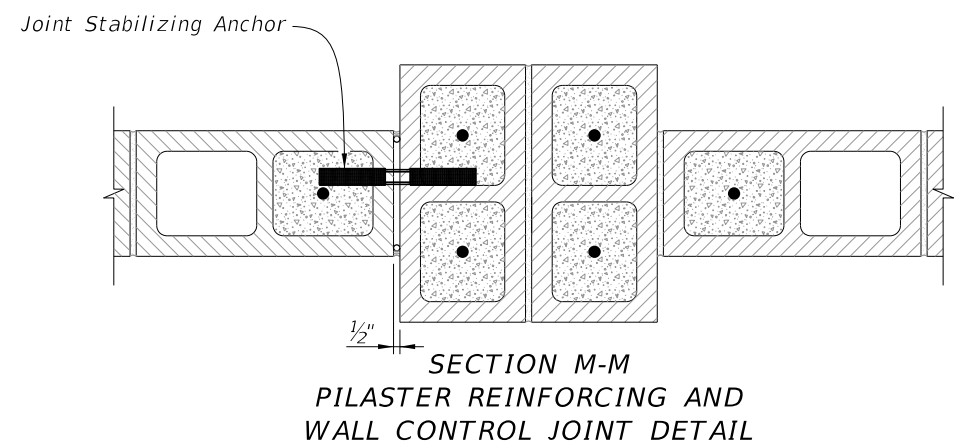
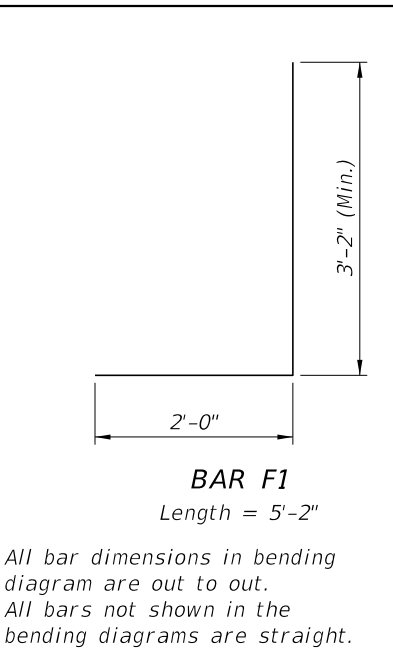

- Notes:
- End vertical reinforcing bars 1/2" from top of bond beam blocks and horizontal bars 1/2" from edge of control joints.
 - Do not continue horizontal #4 Bond beam reinforcing through control joint.
 - Use stainless steel joint stabilizing anchors spaced at 16" vertically at all control joints. Install per manufacturers instructions.
 - Seal Control Joints with backer rod and Type "A" silicone sealant (top and both sides).
 - See Sheet 10 for Bar placement details.
 - For Pilaster Cap Details, see Sheet 2.

MASONRY OPTION

10/3/2023 1:30:31 PM

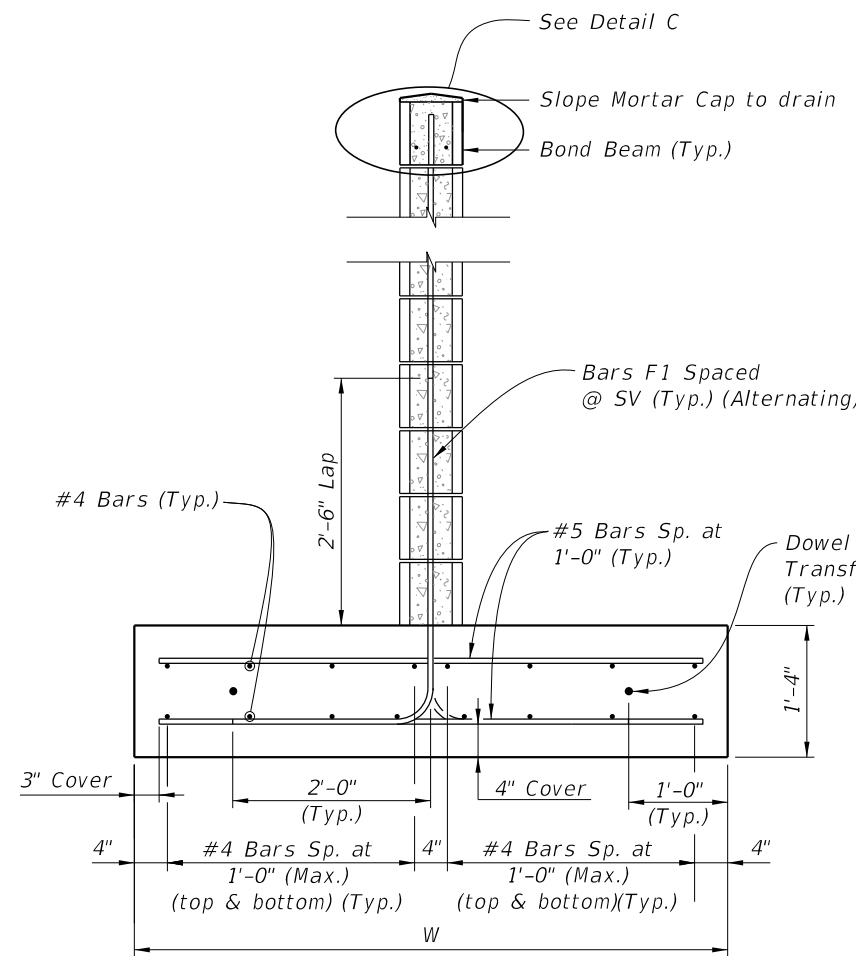

**SECTION K-K
TYPICAL WALL SECTION
WITH T-FOOTING**

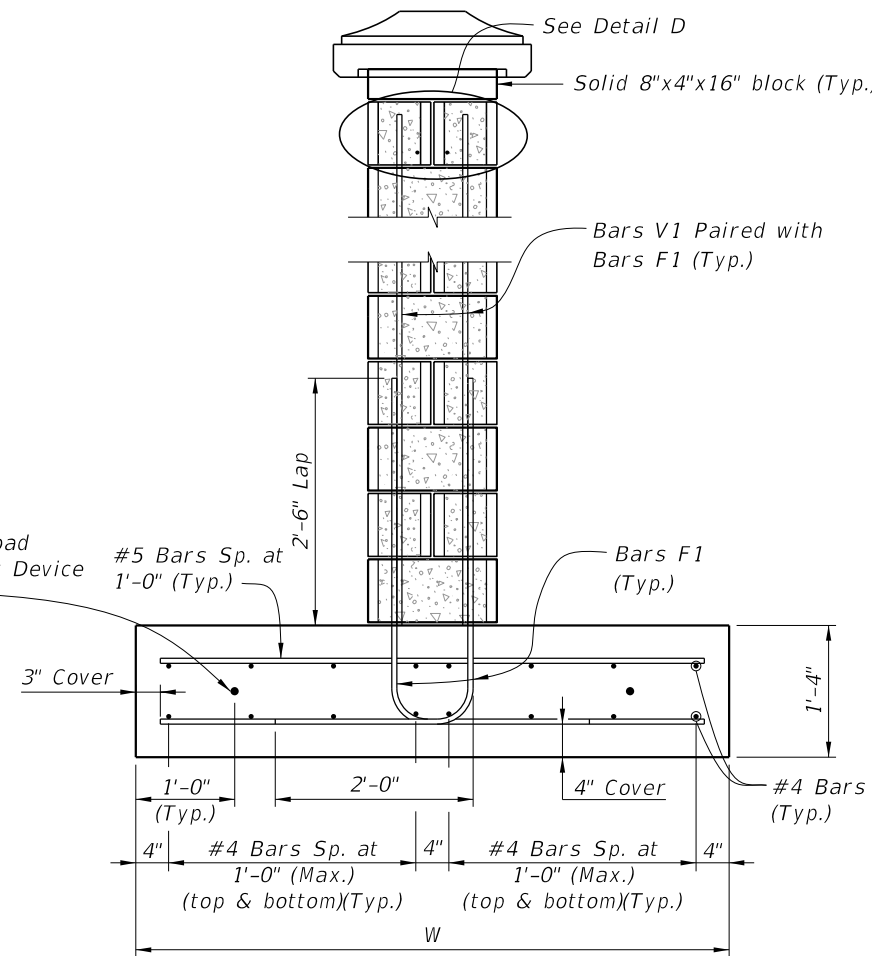

**SECTION L-L
PILASTER SECTION
WITH T-FOOTING**

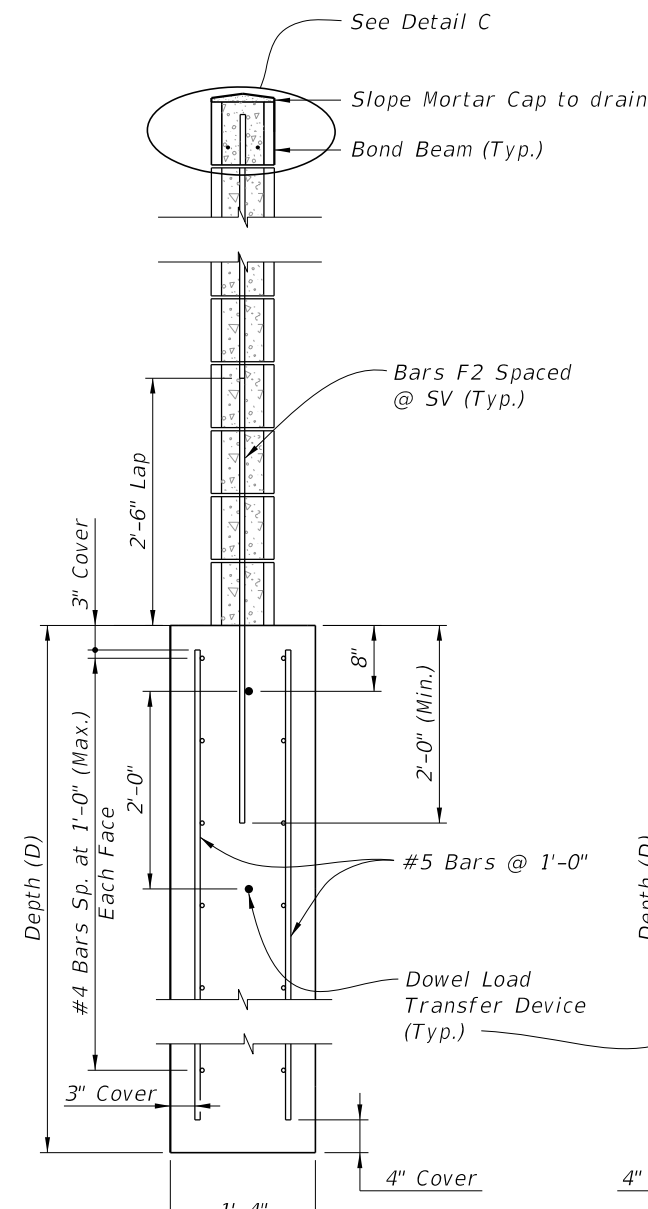

**SECTION K-K
TYPICAL WALL SECTION
WITH TRENCH FOOTING**

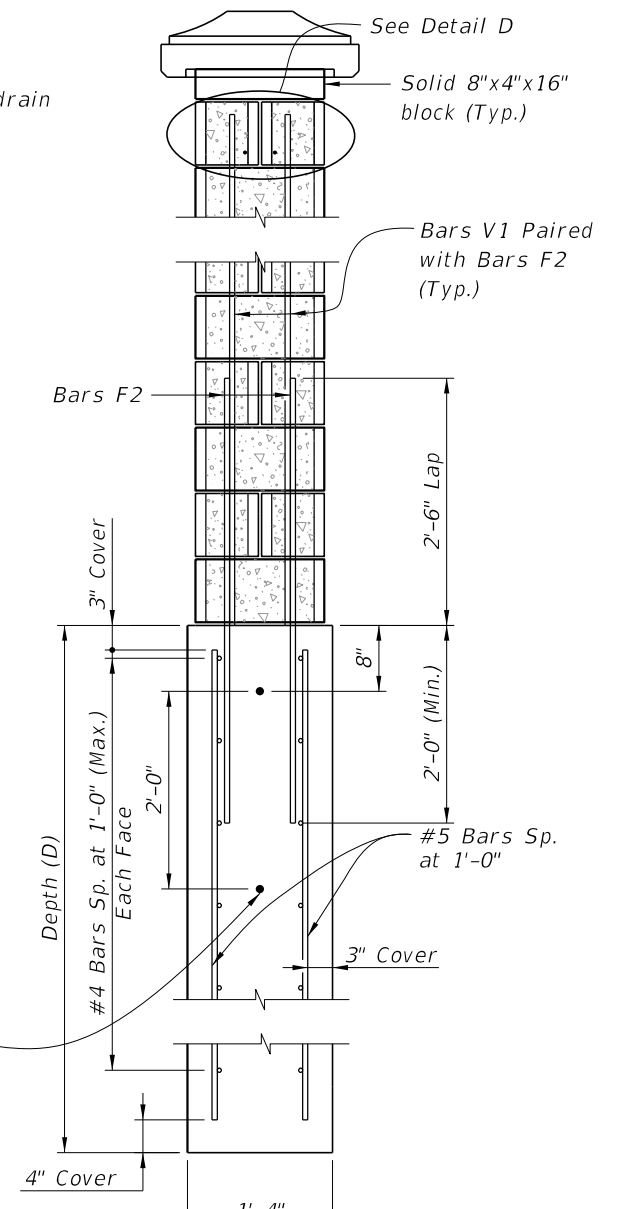

**SECTION L-L
TYPICAL PILASTER SECTION
WITH TRENCH FOOTING**

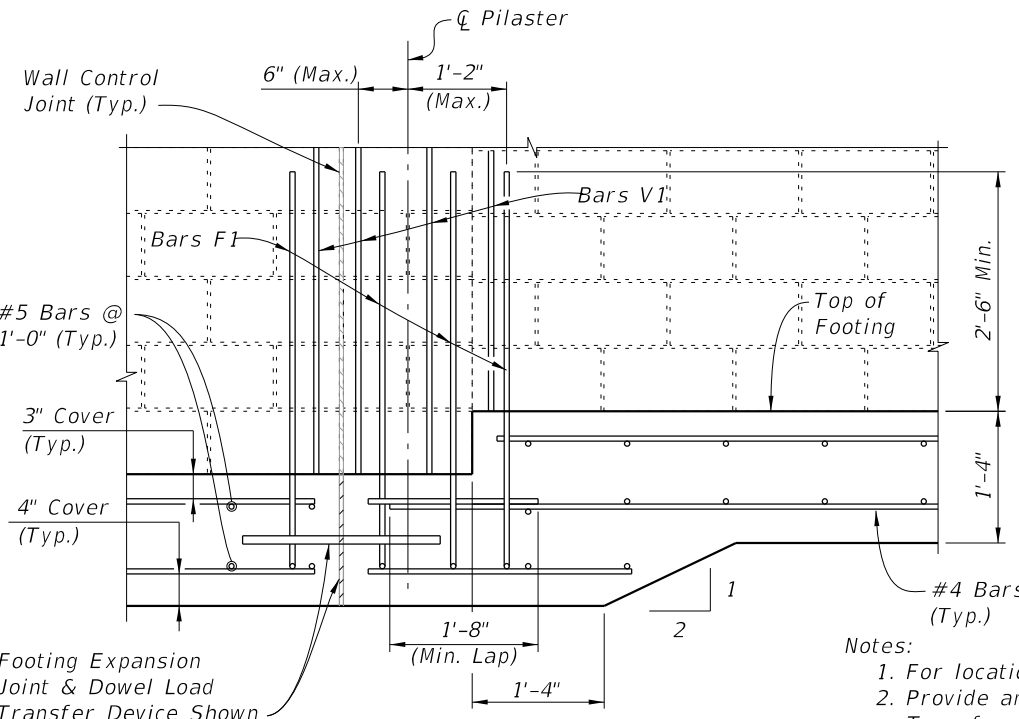

**REINFORCING AT PILASTER WITH EXPANSION JOINT
(Step Shown, without Step Similar)
(T-Footing Shown, Trench Footing Similar)**

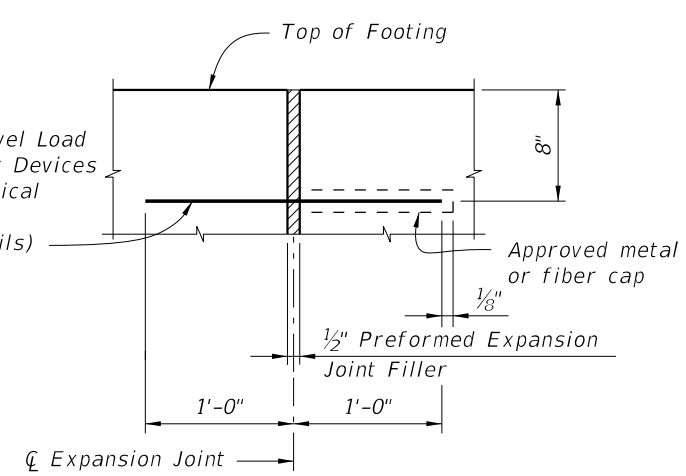

EXPANSION JOINT DETAILS

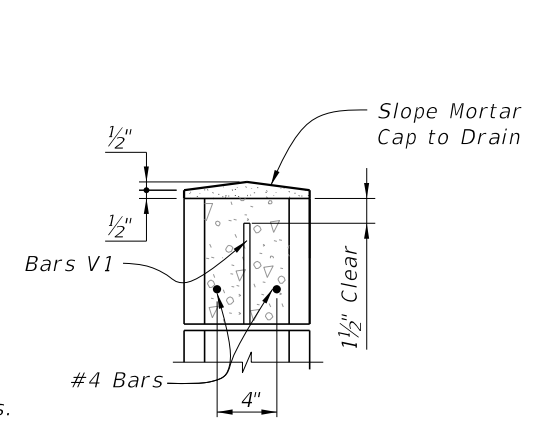

DETAIL C

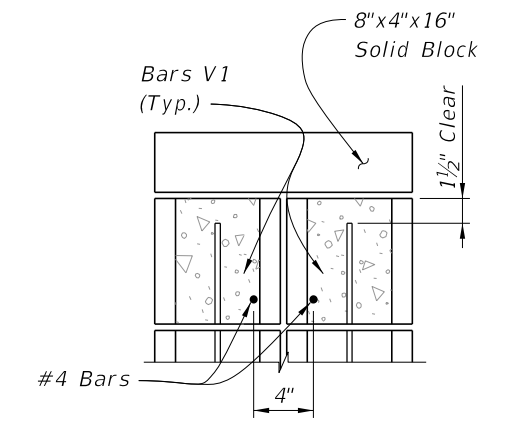

DETAIL D

- Notes:
1. For location of Sections K-K and L-L see Sheet 9.
 2. Provide and install 1/2" Preformed Expansion Joints with 2 ~ 1" Ø Dowel Load Transfer Devices at 90' Max. as shown. See Sections L-L for placement details.
 3. For Reinforcing sizes and spacings, see Table 2, Sheet 9.
 4. Pairs F1, V1 are required in the wall cells on both sides of pilasters, plus a pair in each pilaster cell. Space wall reinforcing per Table 2, Sheet 9.

MASONRY OPTION

10/3/2023 1:30:36 PM

LAST REVISION 11/01/16	DESCRIPTION:		FY 2024-25 STANDARD PLANS	PERIMETER WALLS	INDEX	SHEET
					534-250	10 of 10