

\* Slip Forming Method of Construction requires the Engineer's approval within the limits shown.  
 \*\* For Index 521-820 - Pedestrian/Bicycle Railing and concrete curb, this dimension is 3 1/2". For raised sidewalks, this dimension is 1'-0" Max.  
 \*\*\* Anchor Bolt pattern orientation shall be as shown.

OPTION 1 & 2  
 PLAN VIEW

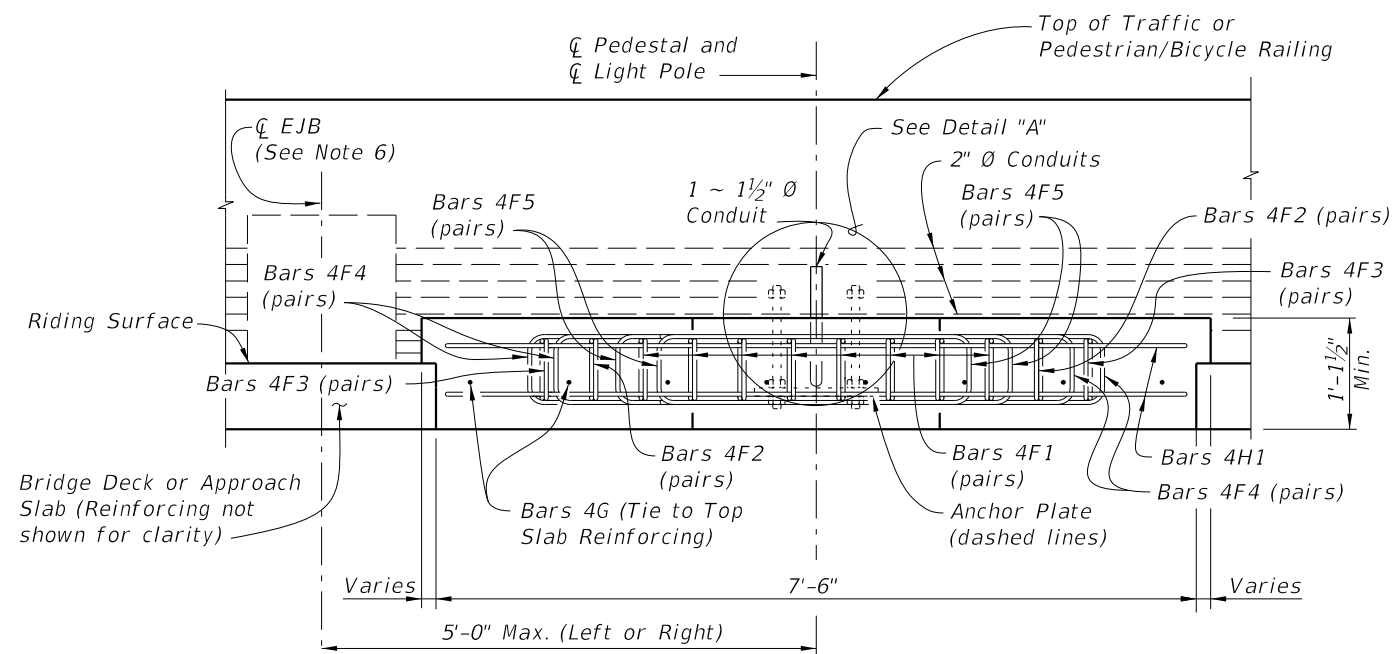

OPTION 1  
 ELEVATION VIEW

(Without Raised Sidewalk shown, with Raised Sidewalk similar)

**CASE 1 LIGHT POLE PEDESTAL FOR APPROACH SLAB OR BRIDGE DECK THICKNESS LESS THAN 1'-5 1/2" AT COPING**

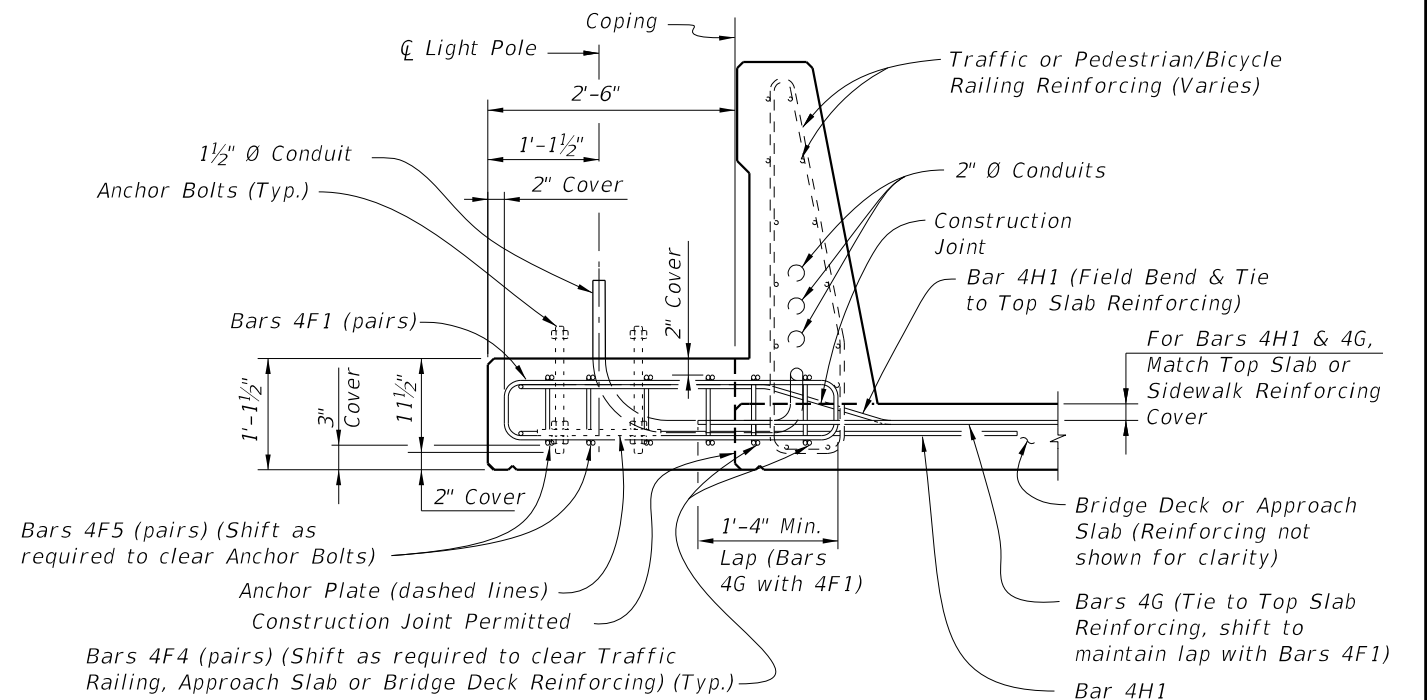

OPTION 1  
 TYPICAL SECTION AT LIGHT POLE PEDESTAL

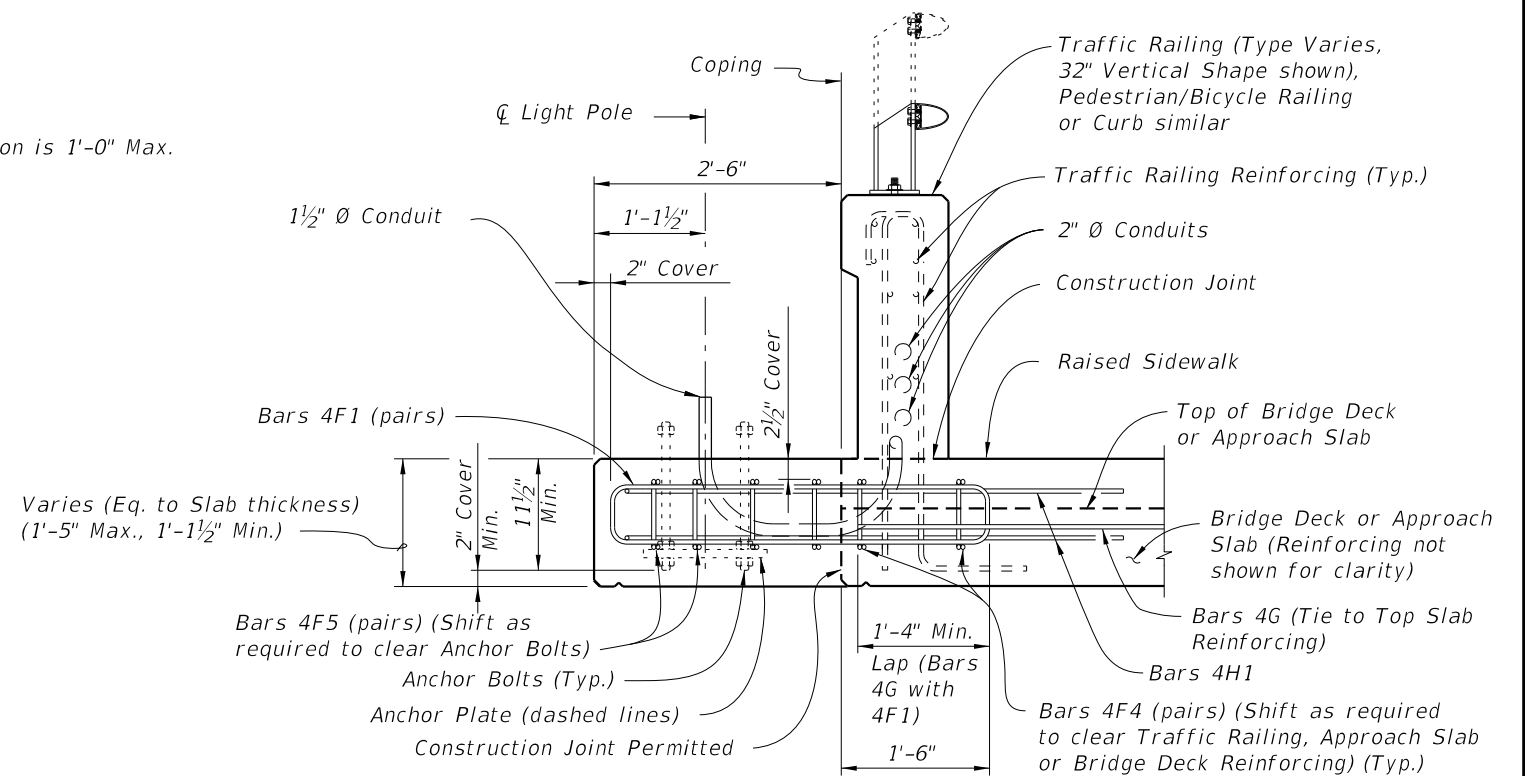

OPTION 1  
 TYPICAL SECTION AT LIGHT POLE PEDESTAL  
 WITH RAISED SIDEWALK

CROSS REFERENCE:  
 For Detail "A", Anchor Plate Detail and Light Pole Pedestal Notes, see Sheet 4.

NOTE: Anchor Bolt, Nuts, Washers and Anchor Plate are dashed for clarity.

10/16/2023 7:44:39 AM

LAST REVISION 11/01/21	DESCRIPTION:	 FY 2024-25 STANDARD PLANS	LIGHT POLE PEDESTAL - BRIDGE	INDEX 521-660	SHEET 1 of 4
---------------------------	--------------	---	------------------------------	------------------	-----------------

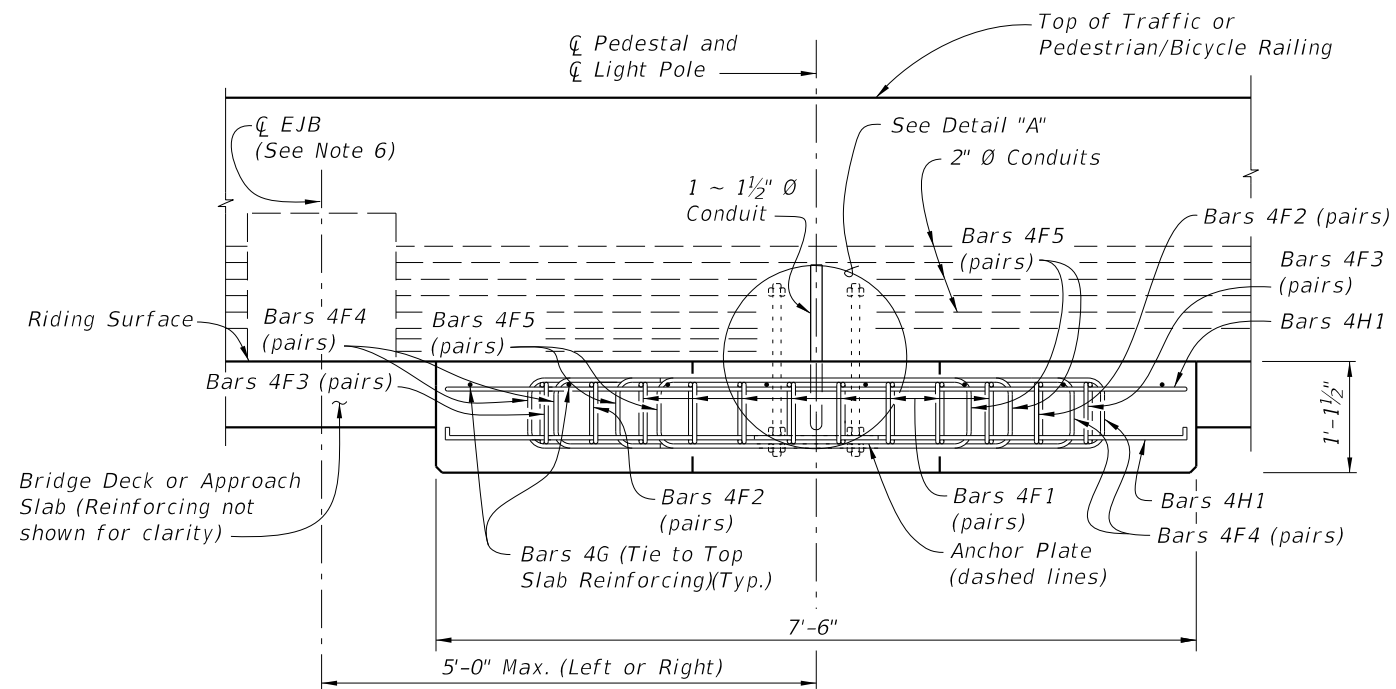

OPTION 2 - ELEVATION VIEW

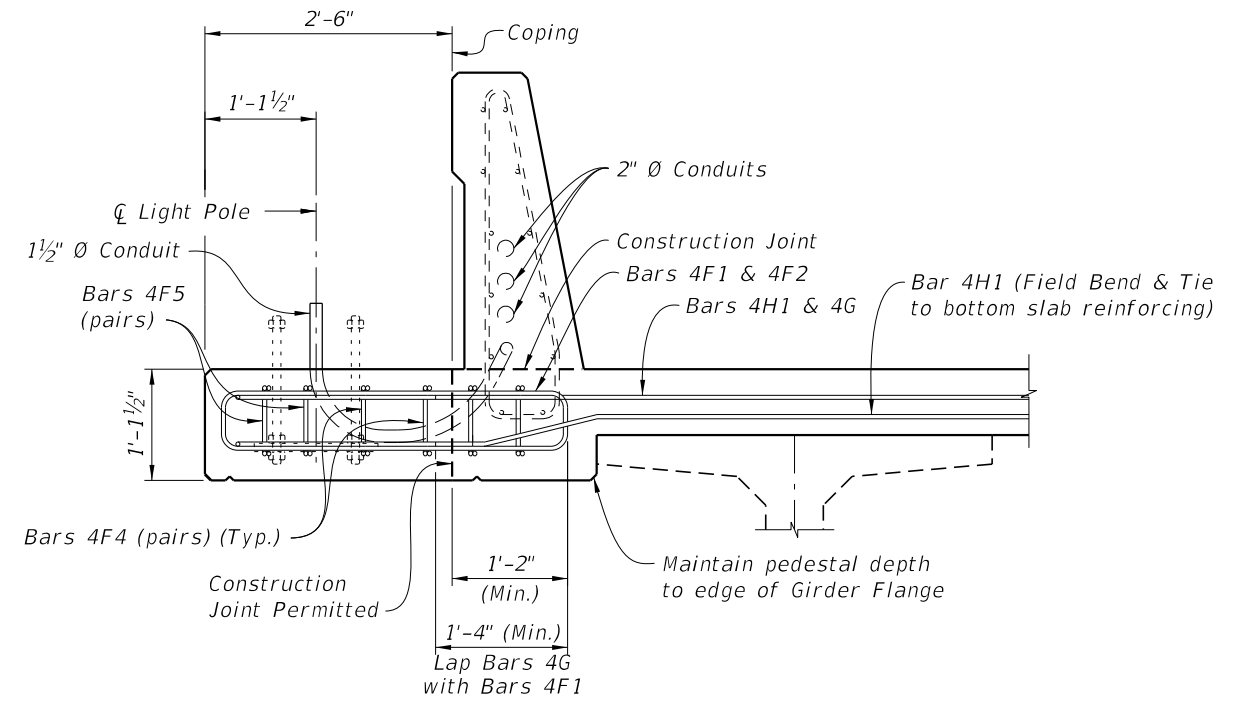

OPTION 2 - TYPICAL SECTION AT LIGHT POLE PEDESTAL (Approach Slab Similar)

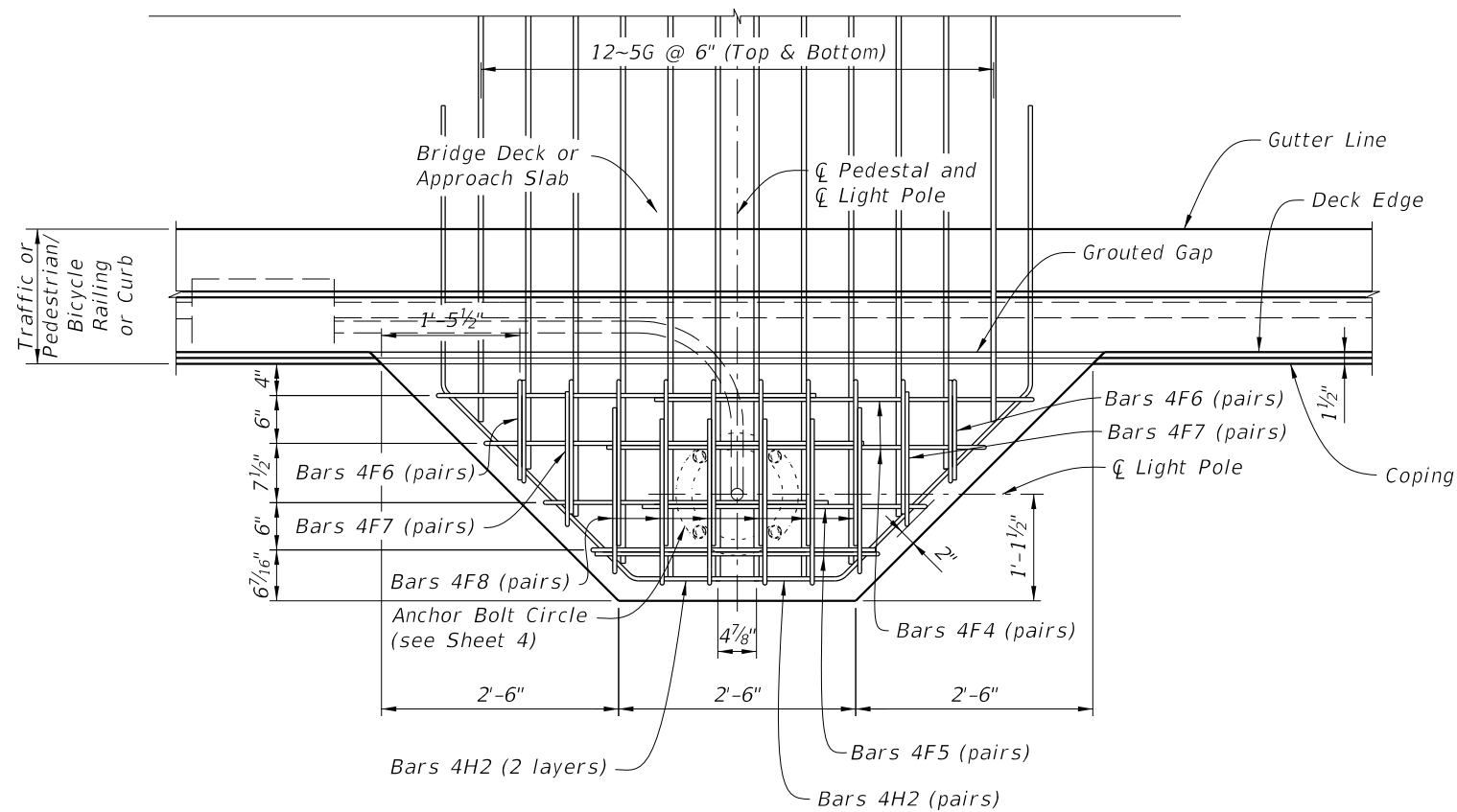

OPTION 3 - PLAN VIEW WITH GAP BETWEEN BARRIER AND PEDESTAL TO ALLOW SLIP FORMING

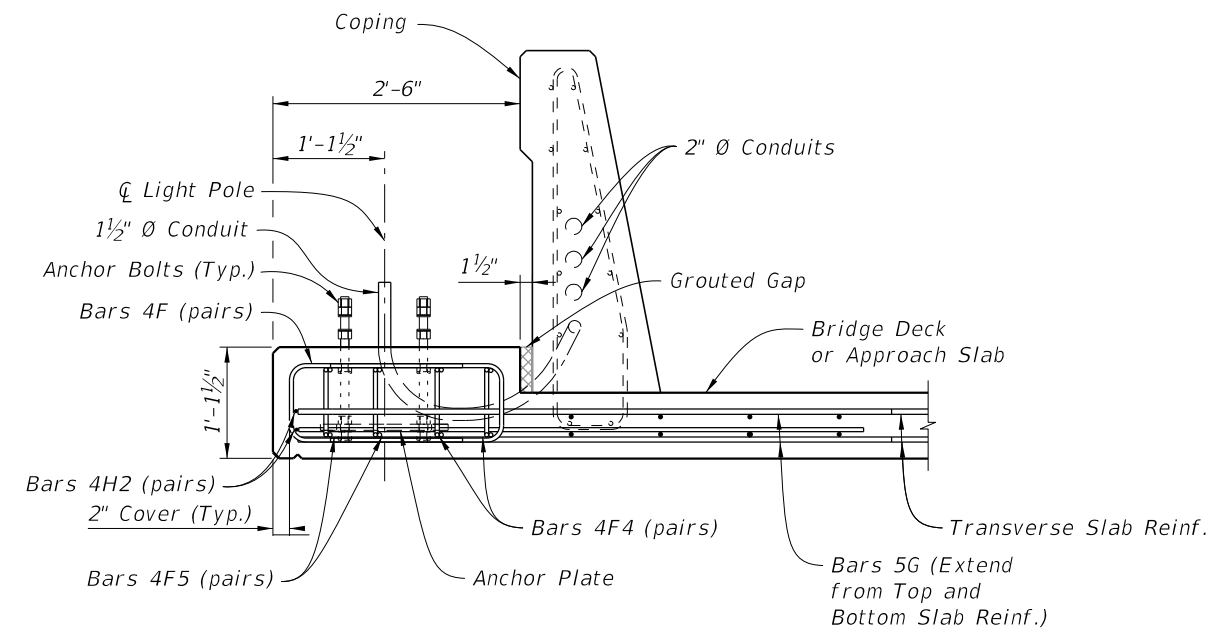

OPTION 3 - TYPICAL SECTION AT LIGHT POLE PEDESTAL WITH GAP BETWEEN BARRIER AND PEDESTAL TO ALLOW SLIP FORMING

CROSS REFERENCE:  
For Detail "A", Anchor Plate Detail and Light Pole Pedestal Notes, see Sheet 4.

NOTE: Anchor Bolt, Nuts, Washers and Anchor Plate are dashed for clarity.

CASE 1 LIGHT POLE PEDESTAL FOR APPROACH SLAB OR BRIDGE DECK LESS THAN 1'-5 1/2" AT COPING

10/16/2023 7:44:50 AM

LAST REVISION 11/01/21	DESCRIPTION:		FY 2024-25 STANDARD PLANS	LIGHT POLE PEDESTAL - BRIDGE	INDEX	SHEET
			521-660		2 of 4	

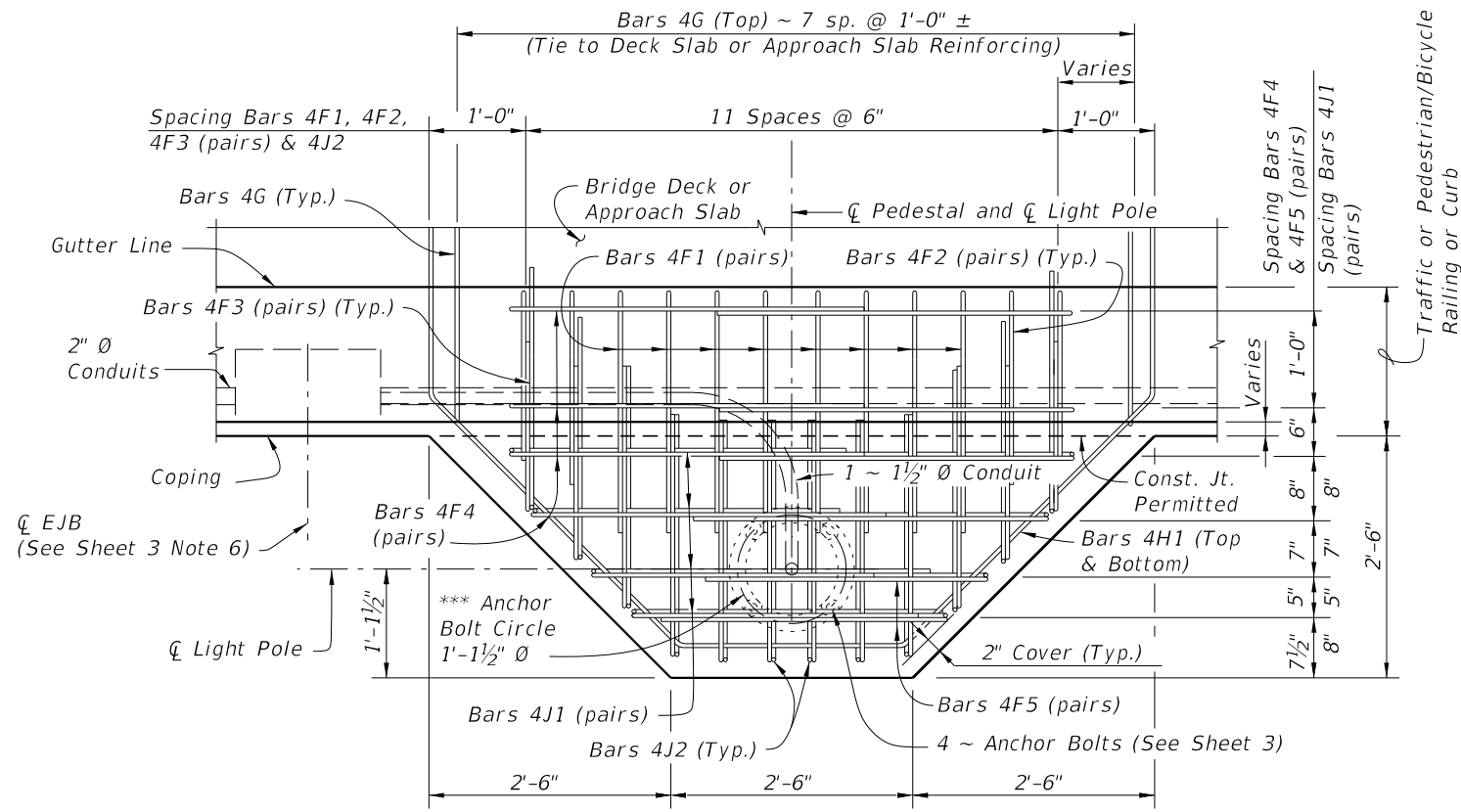

\*\*\* Anchor Bolt pattern orientation shall be as shown.

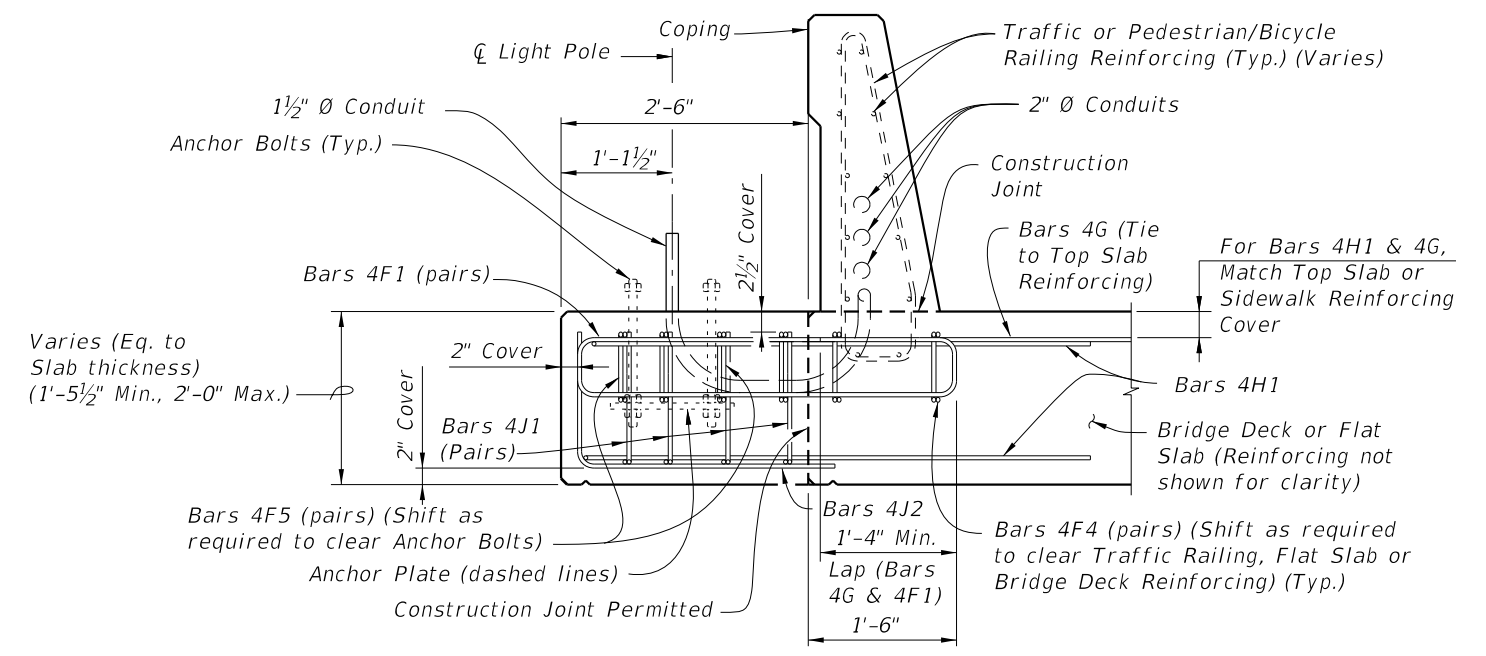
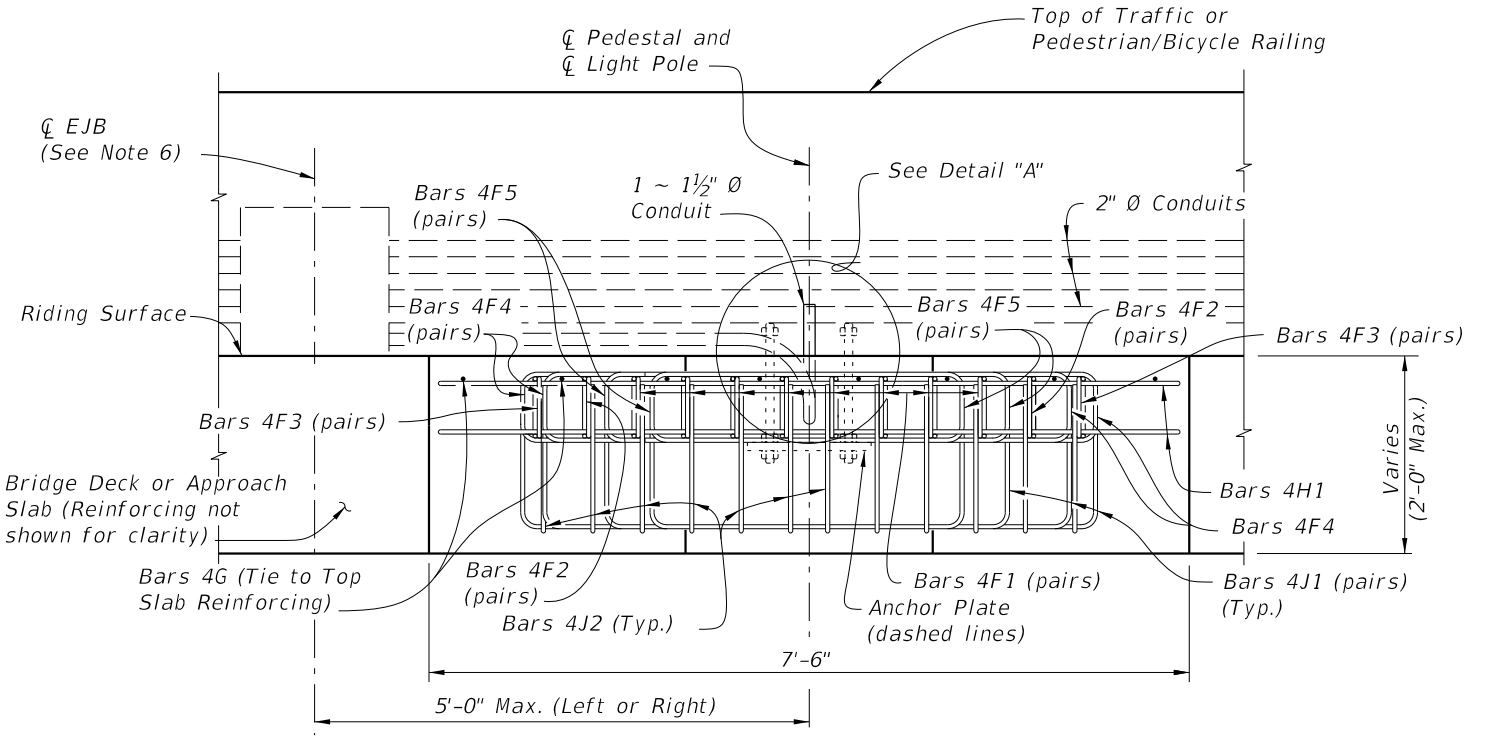

TYPICAL SECTION AT LIGHT POLE PEDESTAL

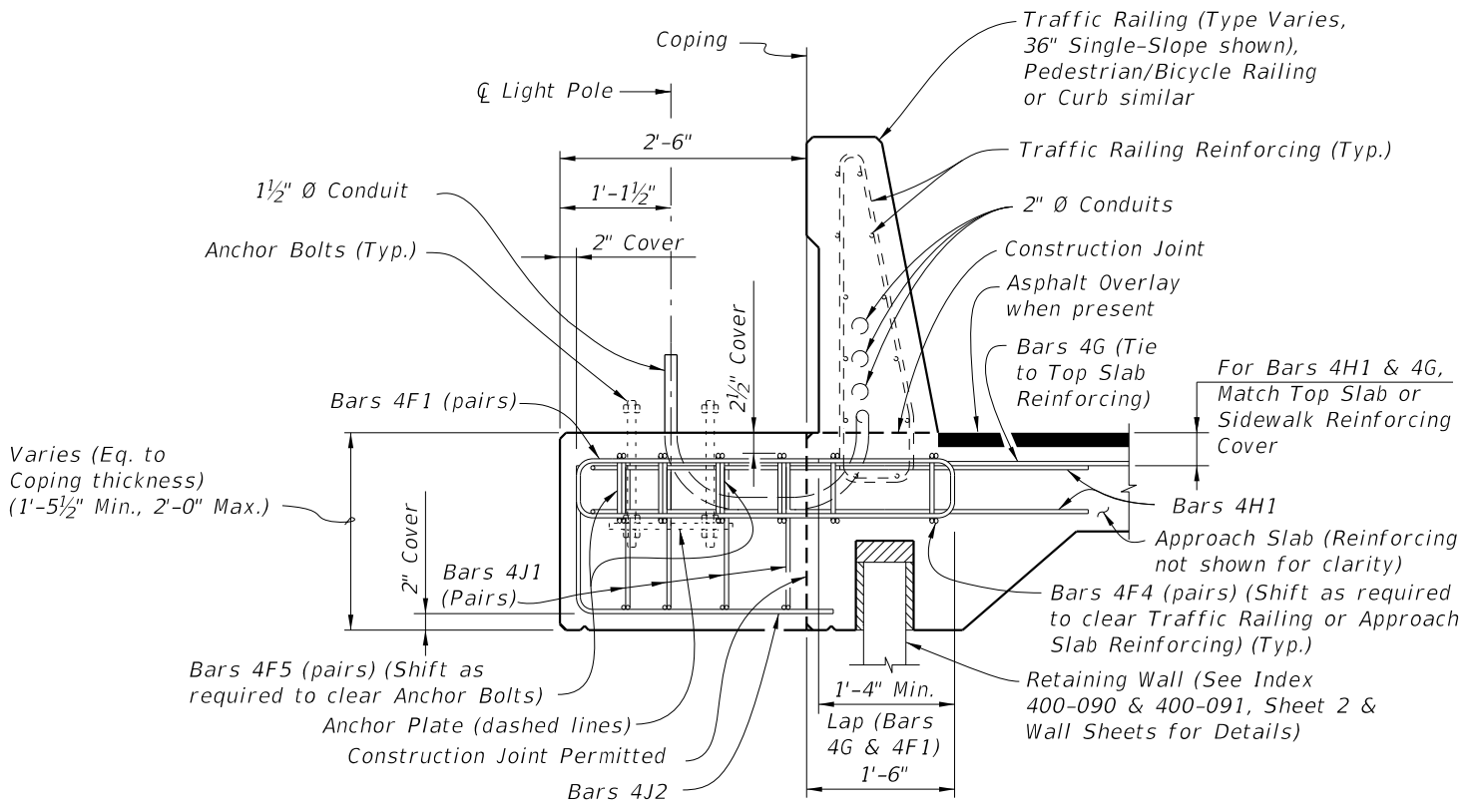

TYPICAL SECTION AT LIGHT POLE PEDESTAL FOR APPROACH SLAB ON RETAINING WALL

CROSS REFERENCE:  
For Detail "A", Anchor Plate Detail and Light Pole Pedestal Notes, see Sheet 4.

NOTE: Anchor Bolt, Nuts, Washers and Anchor Plate are dashed for clarity.

**CASE 2 LIGHT POLE PEDESTAL FOR APPROACH SLAB OR BRIDGE DECK THICKNESS AT COPING 1'-5 1/2" OR GREATER**

10/16/2023 7:45:00 AM

LAST REVISION 11/01/21	REVISION	DESCRIPTION:		FY 2024-25 STANDARD PLANS	LIGHT POLE PEDESTAL - BRIDGE	INDEX 521-660	SHEET 3 of 4
---------------------------	----------	--------------	--	------------------------------	------------------------------	------------------	-----------------

CONVENTIONAL REINFORCING STEEL BENDING DIAGRAMS

REINFORCING STEEL NOTES:

- a. When Pedestal is attached to Pedestrian/Bicycle Railing - Index 521-820 or an 8" wide concrete curb and the Bridge Deck or Approach Slab thickness is less than 1'-1 1/2", Bars 4F3 shall have leg length and bar length shown in parentheses.
- b. The number of bars shown in parentheses is for Bars 4F4 when Pedestal is attached to Pedestrian/Bicycle Railing - Index 521-820 or an 8" wide concrete curb, and the Bridge Deck or Approach Slab thickness is less than 1'-1 1/2".
- c. Lap Splices for Bars 4F1, 4F2 & 4F3 shall be a minimum of 1'-4". Lap Splices for Bars 4F4 & 4F5 shall be minimum of 1'-8".
- d. Bars 4J1 and 4J2 are not required when Pedestal thickness is less than 1'-5 1/2". Field trim height of bars to maintain cover when Pedestal thickness is less than 2'-0". Field trim length of Bars 4J2 on Retaining Wall Coping to maintain cover.
- e. All bar dimensions in the bending diagrams are out to out.

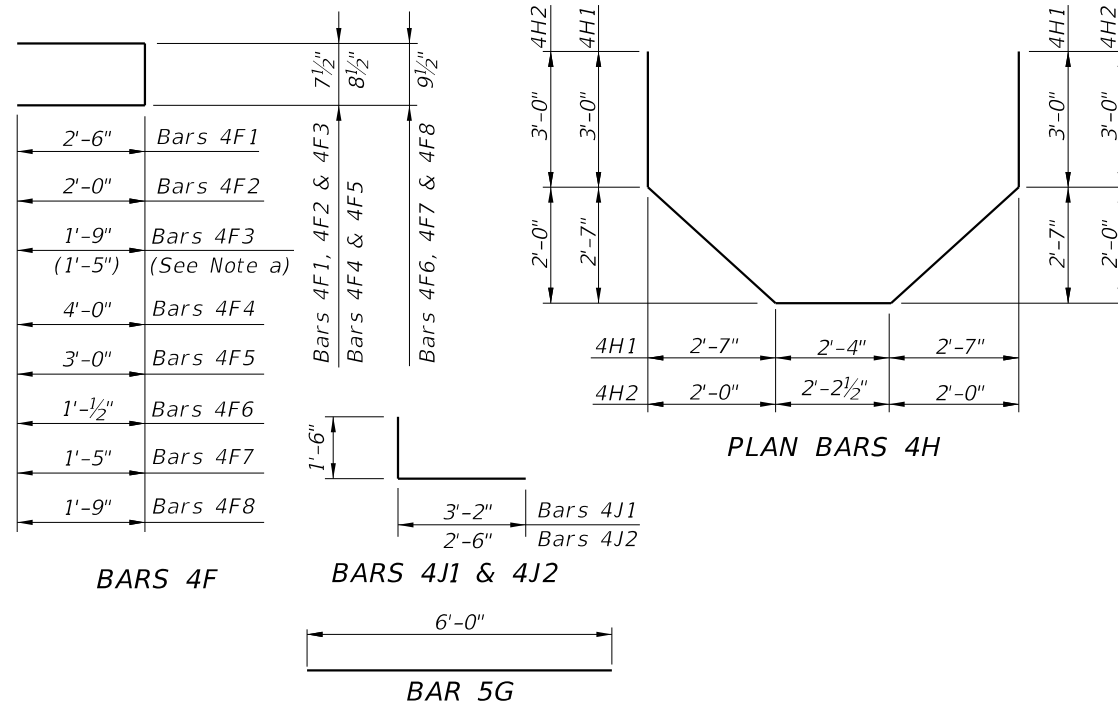

BILL OF REINFORCING STEEL

MARK	SIZE	NO. REQD.	LENGTH	NOTES
F1	4	16	5'-8"	c
F2	4	4	4'-8"	c
F3	4	4	4'-2" (3'-6")	a, c
F4	4	8 (6) [4 for Option 3]	8'-9"	b, c
F5	4	4	6'-9"	c
F6	4	4	2'-11"	-
F7	4	4	3'-8"	-
F8	4	12	4'-4"	-
G	4	8 [5 for Option 3] [24 for Option 3]	6'-0"	-
H1	4	2	15'-8"	-
H2	4	2	13'-10"	-
J1	4	8	4'-8"	d
J2	4	12	4'-0"	d

( ) See Reinforcing Steel Note a & b.

LIGHT POLE PEDESTAL NOTES

1. Concrete and Reinforcing Steel required for the construction of the Pedestal shall meet the same requirements as the Traffic Railing or Pedestrian/Bicycle Railing the Pedestal is attached to.
2. Light Pole Pedestal may be used with the following:  
 Index 521-422 - Traffic Railing (42" Vertical Shape),  
 Index 521-423 - Traffic Railing (32" Vertical Shape),  
 Index 521-427 - Traffic Railing (36" Single-Slope),  
 Index 521-428 - Traffic Railing (42" Single-Slope),  
 Index 521-820 - Pedestrian/Bicycle Railing,  
 Index 515-021 - Pedestrian/Bicycle Railing for Traffic Railing or  
 Index 515-509 - Traffic Railing /Noise Wall - Bridge.
3. Unless otherwise noted, Traffic Railing (36" Single-Slope) is shown in all Views and Sections. The Pedestal details for other Traffic Railings or Pedestrian/Bicycle Railing are similar.

4. ANCHOR BOLTS:

Anchor Bolt design is based on the standard Roadway Aluminum Light Pole configurations shown on Index 715-002.

Anchor Bolt Diameter: See Table 1  
 Anchor Bolts: ASTM F1554 Grade 55.  
 Nuts: ASTM A563 Grade A, Heavy-Hex.  
 Washers: ASTM F436 Type 1.  
 Anchor Plate: ASTM A709 (Grade 36) or ASTM A36.  
 Coating: Galvanize all Nuts, Bolts Washers, in accordance with ASTM F2329.  
 Galvanize plates in accordance with ASTM A123.

The Contractor is responsible for ensuring the anchor bolt configuration is compatible with the light pole base plate. Submit modifications of the anchor bolt design to the Engineer for approval.

5. Install Anchor Bolts plumb.

6. For Conduit, Embedded Junction Boxes (EJB), Expansion/Deflection Fitting and adjacent Reinforcing Steel Details, see Utility Conduit Detail Sheets and Index 630-010.

7. PAYMENT: The cost of Wire Screen, Anchor Bolts, Nuts, Washers and Anchor Plates shall be included in the Bid Price for Light Poles. The cost of all Labor, Concrete and Reinforcing Steel required for the Construction of the Pedestals, and Miscellaneous Hardware required for the completion of the Electrical System, shall be included in the Bid Price for the Traffic Railing or Pedestrian/Bicycle Railing the Pedestal is attached to.

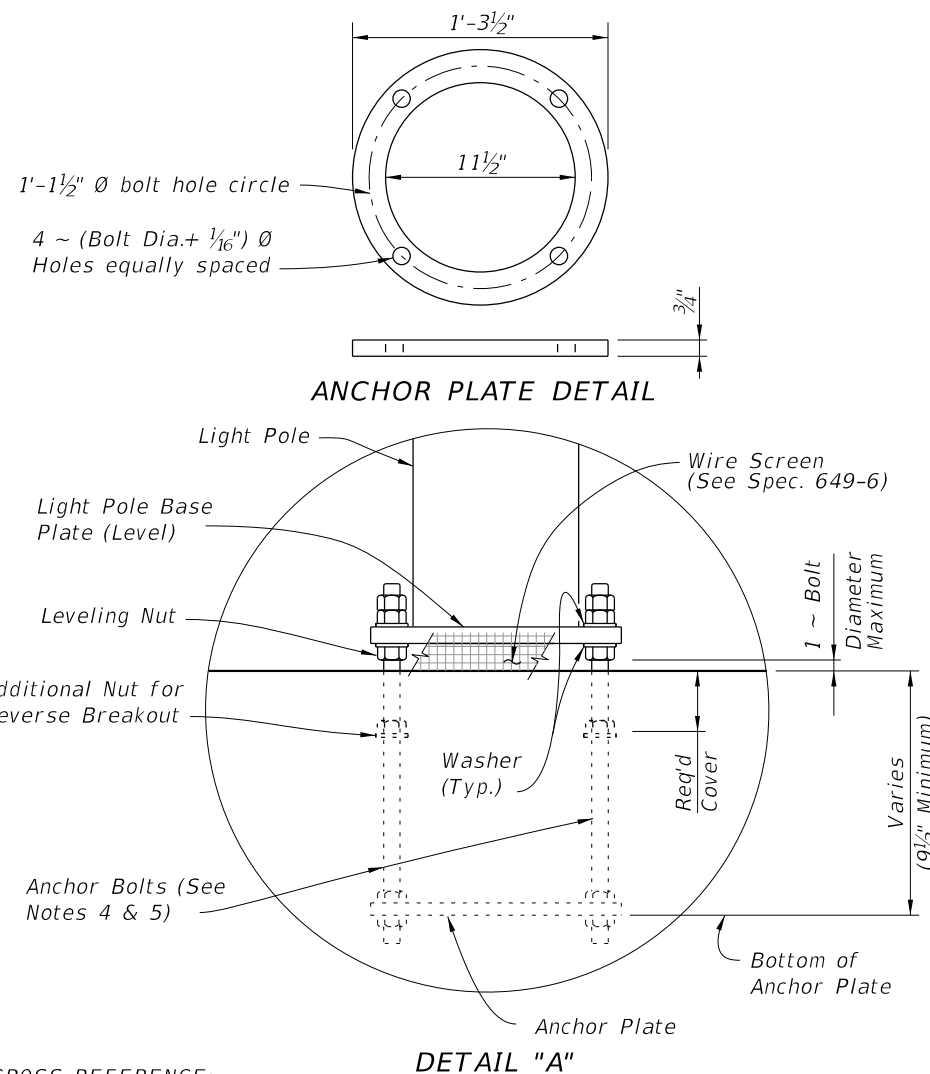

TABLE 1 - DESIGN LIMITATIONS FOR ANCHOR BOLTS (1" Dia.)

WIND SPEED (MPH)	ARM LENGTH (Ft.)	BRIDGE DECK HEIGHT (Ft.)*		
		40 Ft.	45 Ft.	50 Ft.
130	≤ 15	75	75	75
150	≤ 15	75	75	75
170	8 & 10	75	75	45**
170	12 & 15	75	75	25**

\* Above natural ground or MLW.  
 \*\* Use 1 1/4" diameter Anchor Bolt for Bridge Deck Height greater than shown, in Table 1, up to 75'.

ESTIMATED LIGHT POLE PEDESTAL QUANTITIES PER LIGHT POLE PEDESTAL

ITEM	UNIT	QUANTITY
Concrete Per Pedestal Thickness	CY/In.	0.040
Reinforcing Steel	LB	195 (182)

(The Reinforcing Steel quantity shown in parenthesis is for a Pedestal attached to Pedestrian/Bicycle Railing - Index 521-820 with Bridge Deck or Approach Slab thinner than 1'-1 1/2". Add 59 Lbs. for Bars 4J1 & 4J2 when Pedestal Thickness is 1'-5 1/2" or greater)

CROSS REFERENCE:  
 For location of Detail "A" see Sheets 1,2 and 3.

10/16/2023 7:45:08 AM

LAST REVISION	DESCRIPTION:
11/01/21	



FY 2024-25  
 STANDARD PLANS

LIGHT POLE PEDESTAL - BRIDGE

INDEX SHEET  
 521-660 4 of 4