

PLAN
SPREAD FOOTING ADJACENT TO SKEWED APPROACH SLAB AND WITH BARRIER WALL INLET

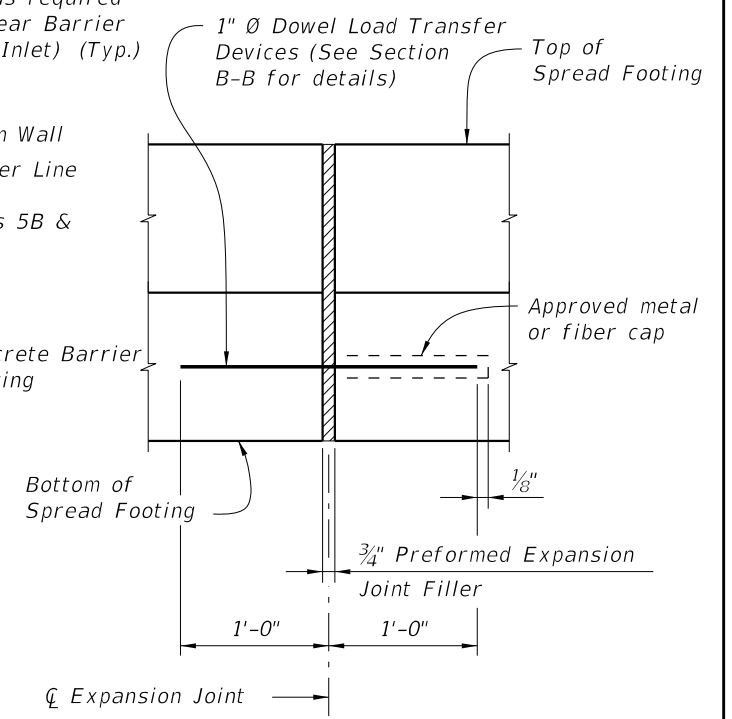

EXPANSION JOINT DETAIL
 (Spread Footing expansion joints are required at 3/4" open joints in Concrete Barrier/Noise Wall)

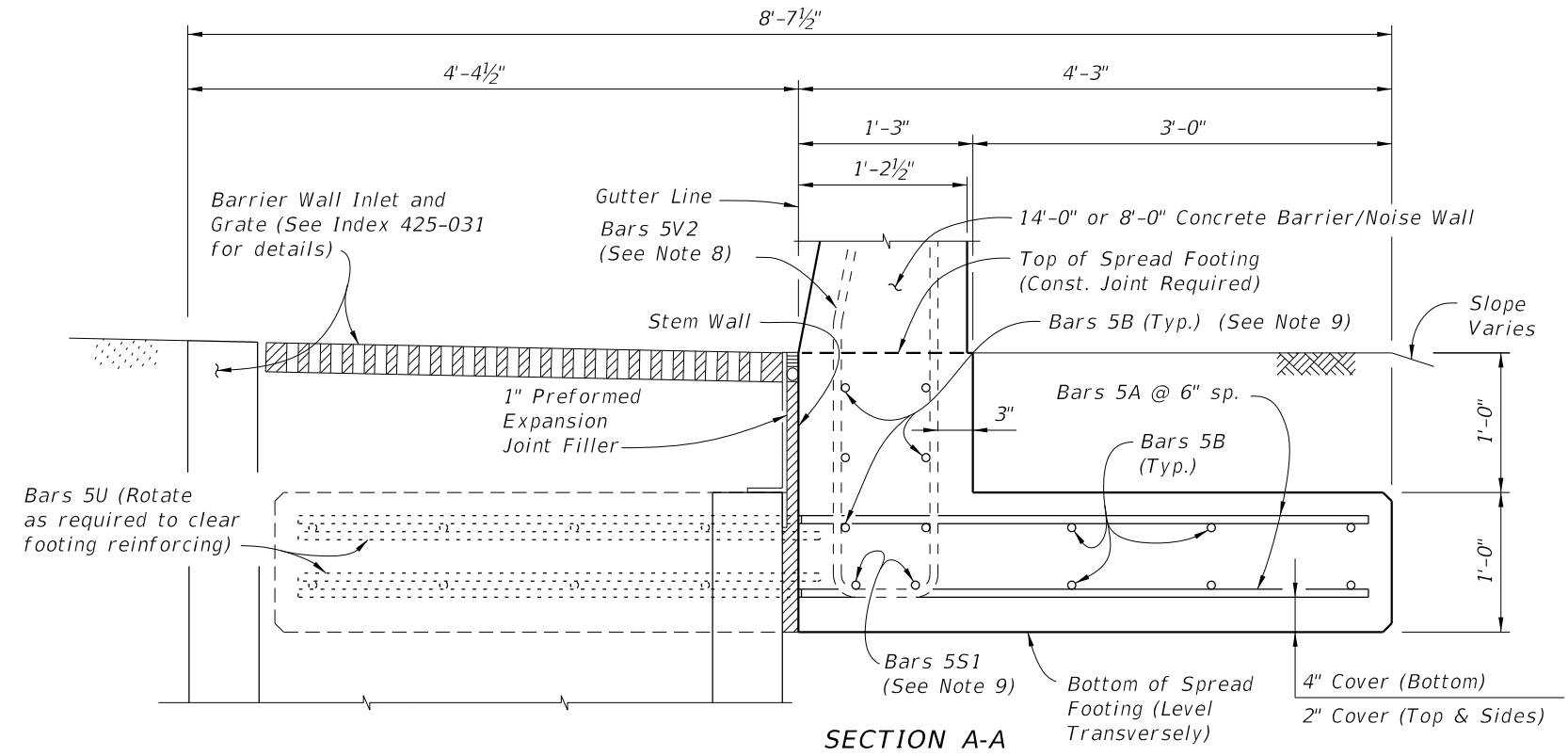

SECTION A-A
SECTION THRU SPREAD FOOTING AND BARRIER WALL INLET
 (Bars 5P, 5R and 5S1 in Concrete Barrier/Noise Wall not shown for clarity)

- NOTES**
- Construct the Spread Footing level transversely and plumb vertically; do not construct the spread footing perpendicular to the roadway surface.
 - Concrete will be in accordance with Specification Section 346.
 - A. Class II concrete for slightly aggressive environments.
 - B. Class IV concrete for moderately or extremely aggressive environments.
 - Dowel Load Transfer Devices will be ASTM A 36 smooth round bar and hot-dip galvanized in accordance with Specification Section 962. Install Dowel Load Transfer Devices in accordance with Specification Section 350.
 - Construct 3/4" Expansion Joints plumb and perpendicular or radial to Gutter Line. Provide at 90'-0" maximum intervals as shown.
 - Construct 1/2" V-Grooves plumb and provide at 30'-0" maximum intervals as shown. Space V-Grooves equally between 3/4" Expansion Joints and/or Begin or End Spread Footing. V-Groove locations are to coincide with V-Groove locations in the Barrier/Noise Wall.
 - Provide and install Preformed Expansion Joint Filler in accordance with Specification Section 932.
 - FILL REQUIREMENTS:** Shoulder or Roadway Pavement or Fill is required on top (1'-0" minimum depth) for the entire length of the spread footing on both sides of the Barrier/Noise Wall. See Section B-B for details.
 - See Index 521-510 for Bars 5V2.
 - Place 8 ~ Bars (6 ~ 5B1 & 2 ~ 5S1) inside Stirrup Bars 5V2 as shown. (2 ~ 5S1 Bars included in 521-510 or 521-511 quantities)
 - Spacing shown is along the Gutter Line.
 - Work this Index with one or both of the following:
 - a. Index 521-510 - Concrete Barrier/Noise Wall (8'-0").
 - b. Index 521-511 - Concrete Barrier/Noise Wall (14'-0").

CROSS REFERENCE:
 For Section B-B and Detail "A", see Sheet 2.

10/3/2023 1:11:23 PM

LAST REVISION 11/01/18	REVISION	DESCRIPTION:		FY 2024-25 STANDARD PLANS	CONCRETE BARRIER/NOISE WALL T-SHAPED SPREAD FOOTING	INDEX 521-513	SHEET 1 of 2
---------------------------	----------	--------------	--	------------------------------	--	-------------------------	------------------------

REINFORCING STEEL BENDING DIAGRAMS

BILL OF REINFORCING STEEL

MARK	SIZE	LENGTH
A	5	6'-8"
B	5	AS REQD.
U	5	11'-0"
DOWEL	1" Ø Smooth Bar	2'-0"

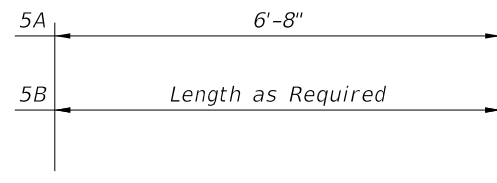

BARS 5A & 5B

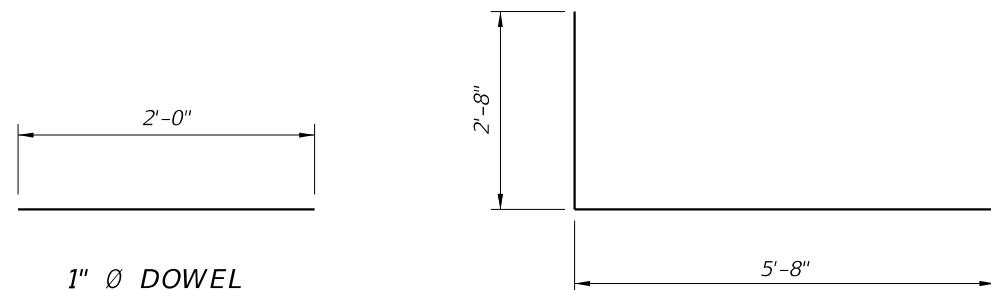

1" Ø DOWEL

BAR 5U

REINFORCING STEEL NOTES:

- All bar dimensions in the bending diagrams are out to out.
- All reinforcing steel at the open joints will have a 2" minimum cover.
- Lap splices for Bars 5B will be a minimum of 2'-2".
- The Contractor may use Welded Wire Reinforcement (WWR) when approved by the Engineer. WWR must consist of Deformed wire meeting the requirements of Specification Section 931.

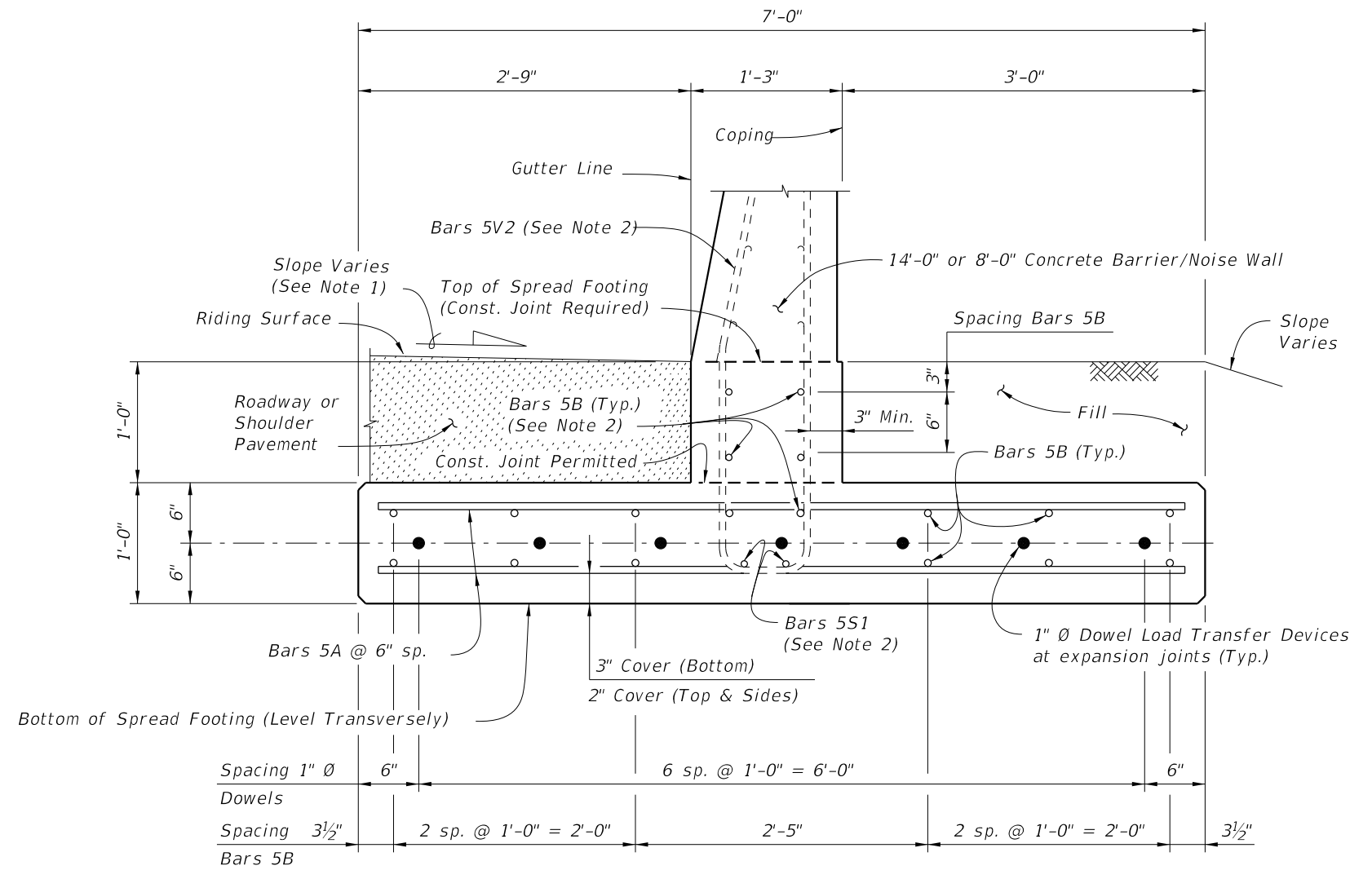

**SECTION B-B
TYPICAL SECTION THRU SPREAD FOOTING
(Bars 5R and 5S1 in Concrete Barrier/Noise Wall not shown for clarity)**

NOTES:

- Match Cross Slope of Travel Lane or Shoulder.
- See Sheet 1, Notes 8 & 9.

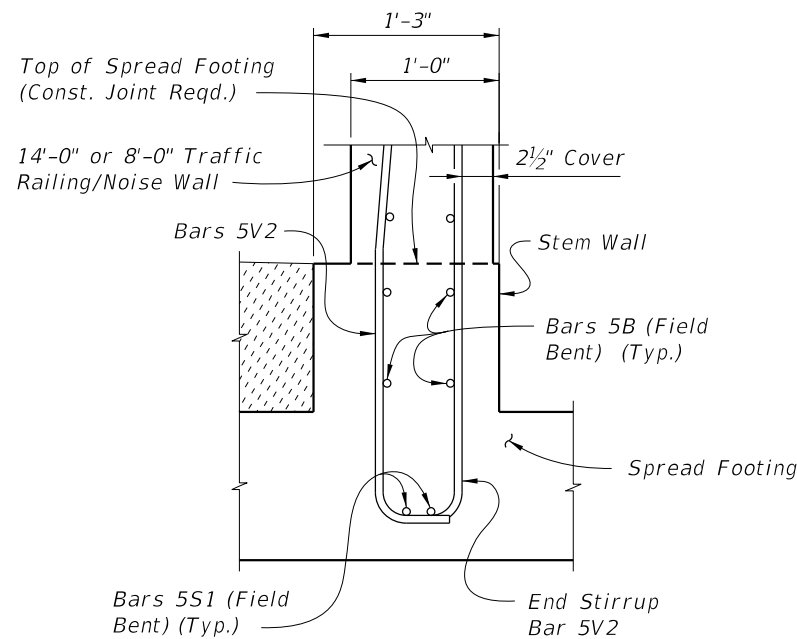

**PARTIAL END VIEW OF RAILING END TRANSITION FOR GUARDRAIL ATTACHMENT
(Showing Bars 5V2, and Bars 5B inside of Stirrup Bars 5V2)**

NOTE: See Index 521-510, Detail "A" for details.

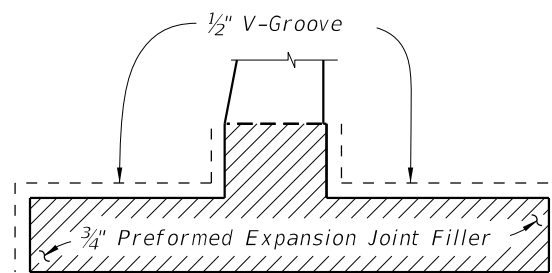

DETAIL "A"

(Showing Locations of 1/2" V-Grooves and 3/4" Preformed Expansion Joint Filler)

ESTIMATED T-SHAPED SPREAD FOOTING QUANTITIES

ITEM	UNIT	QUANTITY
Concrete (Footing)	CY/FT	0.312
Reinforcing Steel (Typical)	LB/FT	47.36
Additional Reinf. @ Expansion Joint	LB	37.38

Note: The reinforcing steel quantity includes the difference between Index 521-510 or 521-511 and Bars 5V shown. Bars 5S1 are included in Index 521-510 or 521-511 quantities.

CROSS REFERENCE:
For location of Section B-B, see Sheet 1.

10/3/2023 1:11:30 PM

LAST REVISION	DESCRIPTION:
11/01/23	