

PLAN
(Reinforcing Steel not shown for clarity)

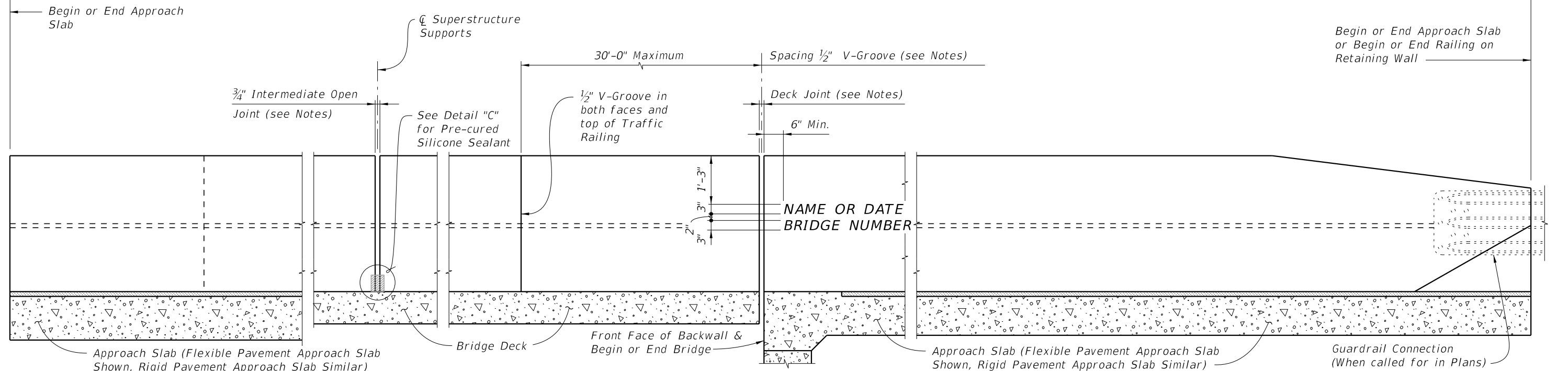

ELEVATION OF INSIDE FACE OF RAILING
(Reinforcing Steel not shown for clarity)
(Railing on Bridge Deck and Approach Slab shown, Railing on Retaining Wall similar)

CROSS REFERENCE:
For Section A-A, End View B-B and Detail "A" see Sheet 2.
For Detail "B" see Sheet 3.
For Detail "C" see Sheet 4.

TRAFFIC RAILING NOTES

1. Materials: See Structures Plans, General Notes
2. Guardrail Connection Details: See Index 536-001
3. Superelevation: Traffic Railings on Superelevated bridges may be constructed perpendicular to the roadway surface. If an adjoining railing is constructed plumb, transition the end of the Traffic Railing from perpendicular to plumb over a minimum distance of 20'-0". The cost of all modifications will be at the Contractor's expense.
4. Name, Date & Bridge Number: Place the Name and Bridge Number on the Traffic Railing on the driver's right side when approaching the bridge. Place the Date on the driver's left side when approaching the bridge. Use the Name as shown in the General Notes of the Structures Plans. The Date is the year the bridge is completed. For a widening when the existing railing is removed, use both the date on the removed rail and the year of the widening. Form letters and figures with 3/8" V-Grooves using preformed letters and figures. Black plastic letters and figures 3" tall may be used, if approved by the Engineer.
5. Open Joints: See the Superstructure Plans, Approach Slab and Retaining Wall Sheets for Deck Joint dimensions and orientation. Provide Open Railing Joints matching the dimensions of the Deck Joint at Deck Expansion Joint locations.
 - A. For treatment of railings on skewed bridges see Index 521-427 Sheet 3.
6. Open Joints: Provide 3/4" Open Joints at:
 - A. Superstructure supports where the slab is continuous.
 - B. At ends of approach slabs when adjacent to retaining walls and at expansion joints on retaining wall junction slabs.
7. V-Grooves: Construct 1/2" V-Grooves plumb. Space V-Grooves equally between 3/4" Open Joints and/or Deck Joints and the at V-Groove locations on the Retaining Wall footing/junction slabs.
8. Barrier Delineators: Install Barrier Delineators on top of the Traffic Railing 2" from the face of the traffic side in accordance with Specification Section 705. Match the Barrier Delineator to the color (white or yellow) of the near edgeline.
9. Traffic Railing Transitions: See Plans for type and location
 - A. Transition to guardrail: See Detail "A" and View B-B.
 - B. Transition to 44" Roadway Concrete Barriers. See Detail "B" and View C-C.
 - C. Transitions to 36" or 38" concrete barriers at end of approach slab: See Detail "C", View D-D and Section E-E.
10. Drainage Slots: See Superstructure Plans for drainage slot locations and size (if required). See Index 521-427 Sheet 5 for details.
11. Embedded conduit and junction boxes: See Index 630-010.

10/16/2023 7:35:10 AM

LAST REVISION 11/01/20	REVISION	DESCRIPTION:		FY 2024-25 STANDARD PLANS	TRAFFIC RAILING - (42" SINGLE-SLOPE)	INDEX 521-428	SHEET 1 of 4
---------------------------	----------	--------------	--	------------------------------	--------------------------------------	------------------	-----------------

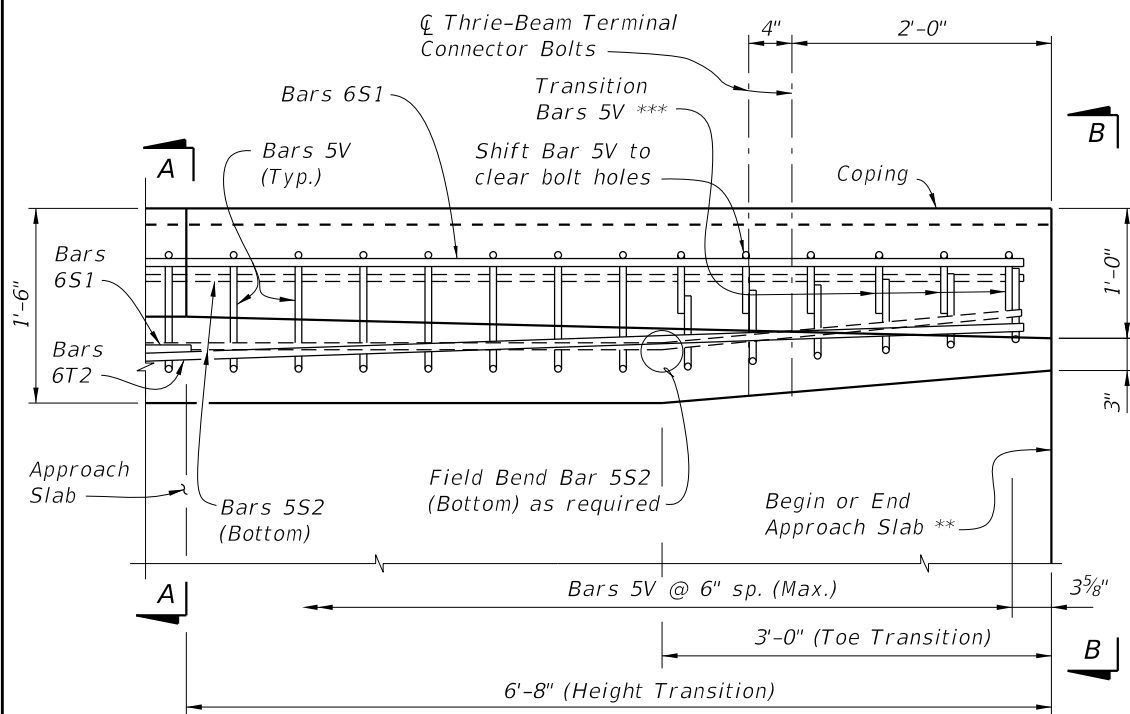

PLAN - RAILING END TRANSITION
(Showing Lower Section with Bars 5V, 6S1, 5S2 and 6T2)

DETAIL "A"

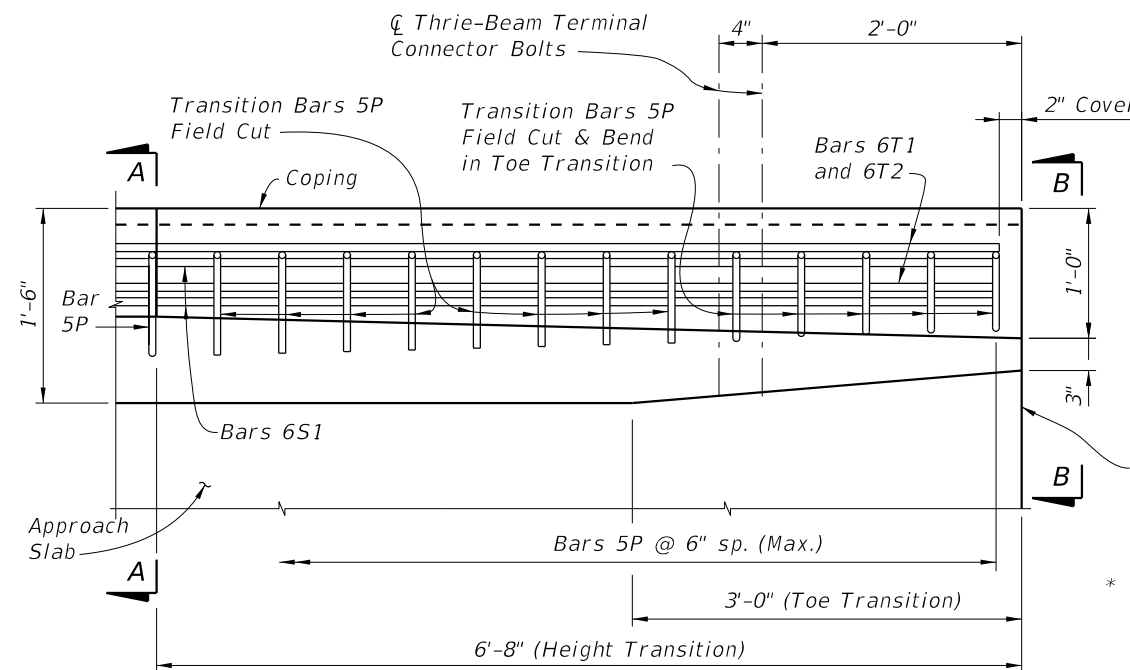

PLAN - RAILING END TRANSITION
(Showing Upper Section with Transition Bars 5P and Bars 6S1, 6T1 & 6T2)

NOTE:
Begin placing Railing Bars 5P and 5V on Approach Slab at the railing end and proceed toward Begin or End Bridge to ensure placement of guardrail bolt holes. If required, adjustments to the bar spacing for Bars 5P and 5V shall be made immediately adjacent to Begin or End Bridge. Shift Bars 5P and 5V (see Detail "A") as required to maintain cover in Railing End Transition.

* Where railings of adjacent bridges are to be built back to back, the outside vertical plane of the railing and deck may coincide along a plane centered 1'-6" from each gutter line. A bond breaker will be required. See Structures Plans, Superstructure Sheets for Details.

** See joint orientation note on Sheet 1.

*** Field Cut & Lap Bars 5V in Toe Transition to maintain clearance.

NOTE:
Omit Detail "A" and provide Detail "B" if 44" Concrete Barrier or Single-Slope Traffic Railing is used beyond the Approach Slab. See Structures Plan and Elevation Sheet and Roadway Plans. If Transitions are not required, extend Typical Section to end of Approach Slab.

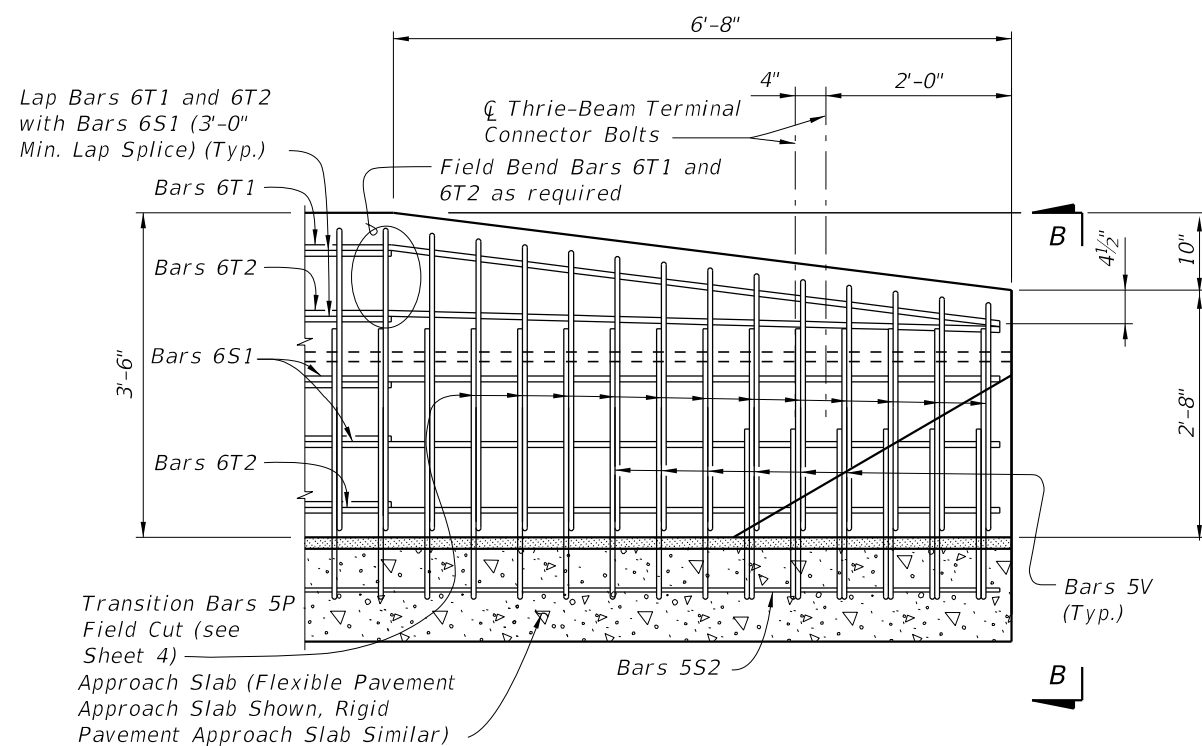

VIEW C-C
ELEVATION - RAILING END TRANSITION
(Guardrail not shown for clarity)

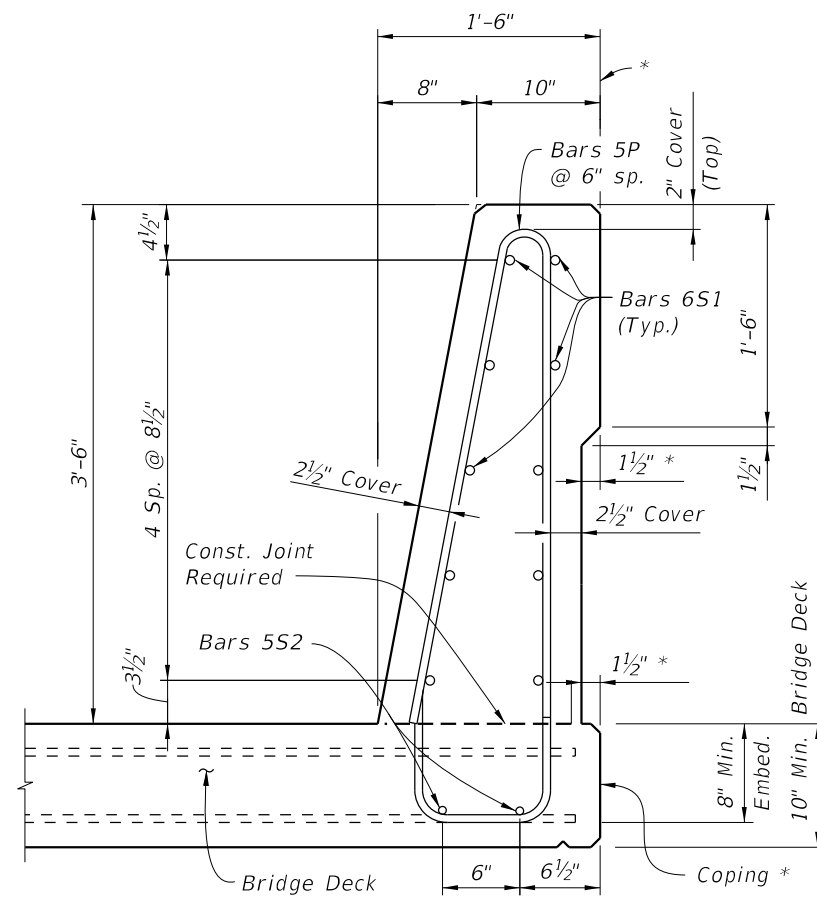

SECTION A-A
TYPICAL SECTION THRU TRAFFIC RAILING
(Section Thru Bridge Deck shown -
Section Thru Approach Slab similar)

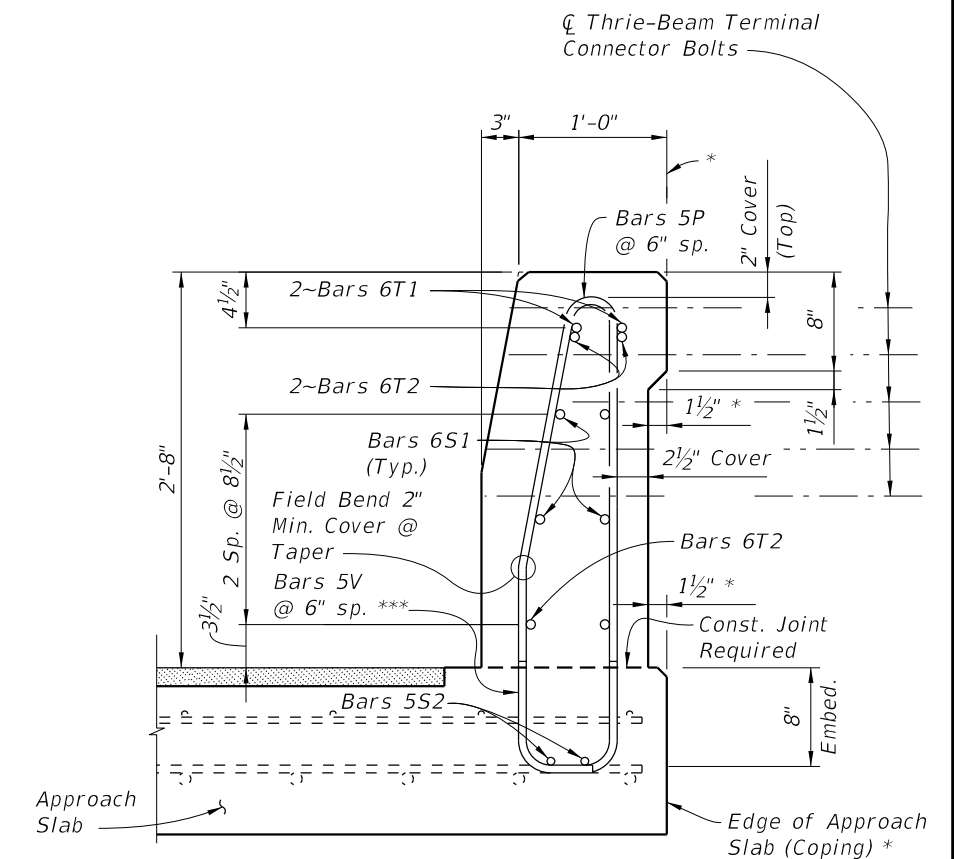

VIEW B-B
END TRANSITION
(Section thru Approach Slab shown,
Section thru Retaining Walls similar)

10/16/2023 7:35:21 AM

LAST REVISION 11/01/17	DESCRIPTION:		FY 2024-25 STANDARD PLANS	TRAFFIC RAILING - (42" SINGLE-SLOPE)	INDEX 521-428	SHEET 2 of 4

- NOTE:
1. Provide Detail "B" height transition where 42" Traffic Railings are required on bridge, and 36" or 38" Barriers are shown on approaches. See Structures Plans for coping details.
 2. Work Detail "B" with Indexes 400-090 or 400-091, 521-427, and 521-610 as necessary.
 3. Field cut 5P Bars as shown to maintain 2" min. (4" max.) cover at top of traffic railing.

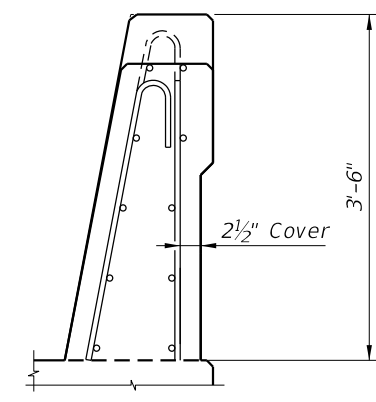
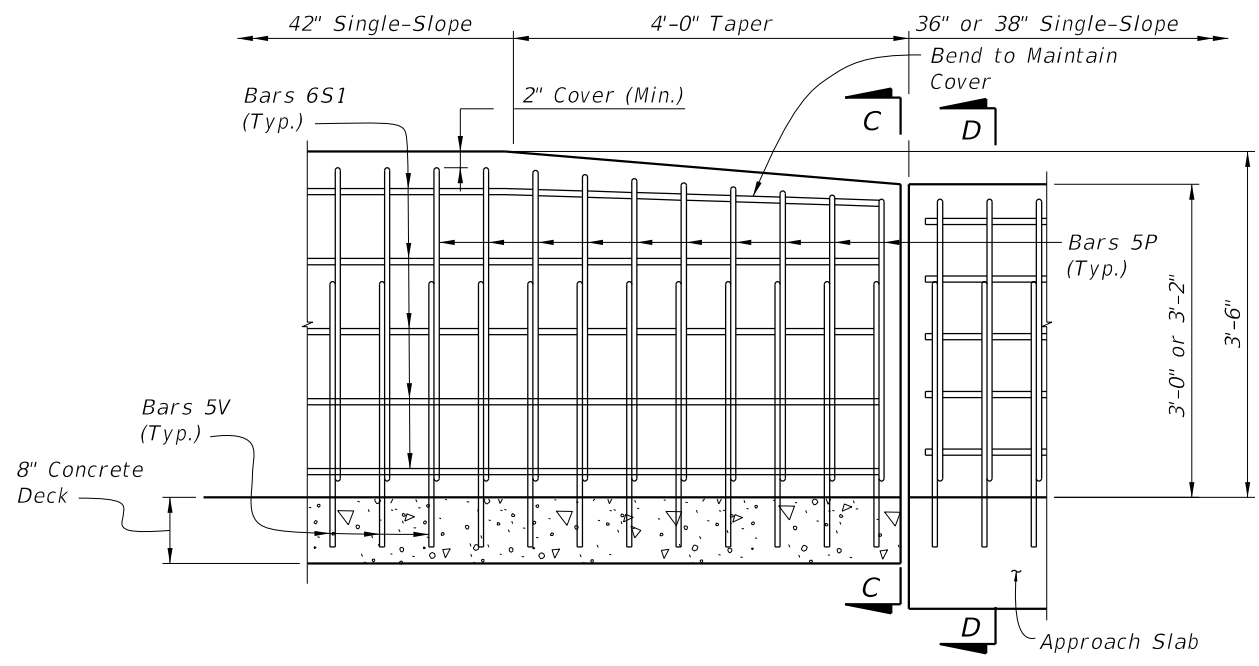

VIEW C-C
RAILING HEIGHT TRANSITION
(Begin/End of Bridge)
(Bars 5V not shown for clarity)

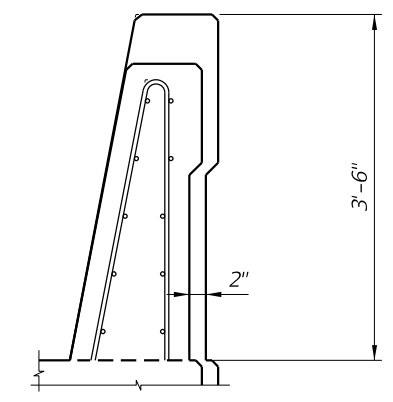

SECTION D-D
(Index 400-091 Shown, 400-090 Similar)
(Index 521-427 Bars 4V not shown for Clarity)

DETAIL "B"

10/16/2023 7:35:31 AM

LAST REVISION 11/01/20	REVISION	DESCRIPTION:		FY 2024-25 STANDARD PLANS	TRAFFIC RAILING - (42" SINGLE-SLOPE)	INDEX 521-428	SHEET 3 of 4
---------------------------	----------	--------------	--	------------------------------	--------------------------------------	------------------	-----------------

CONVENTIONAL REINFORCING STEEL BENDING DIAGRAMS

BILL OF REINFORCING STEEL		
MARK	SIZE	LENGTH
P	5	7'-0"
S1	6	As Req'd.
S2	5	As Req'd.
T1 & T2	6	10'-0"
V	5	5'-9"

ROADWAY CROSS-SLOPE	LOW GUTTER	HIGH GUTTER
	∅B	∅B
0% to 2%	101°	101°
2% to 6%	98°	104°
6% to 10%	95°	107°

∅A and ∅B shall be 90° if Contractor elects to place Railing perpendicular to the Deck.

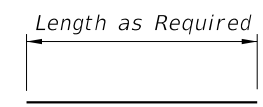

BARS 6S1 & 5S2

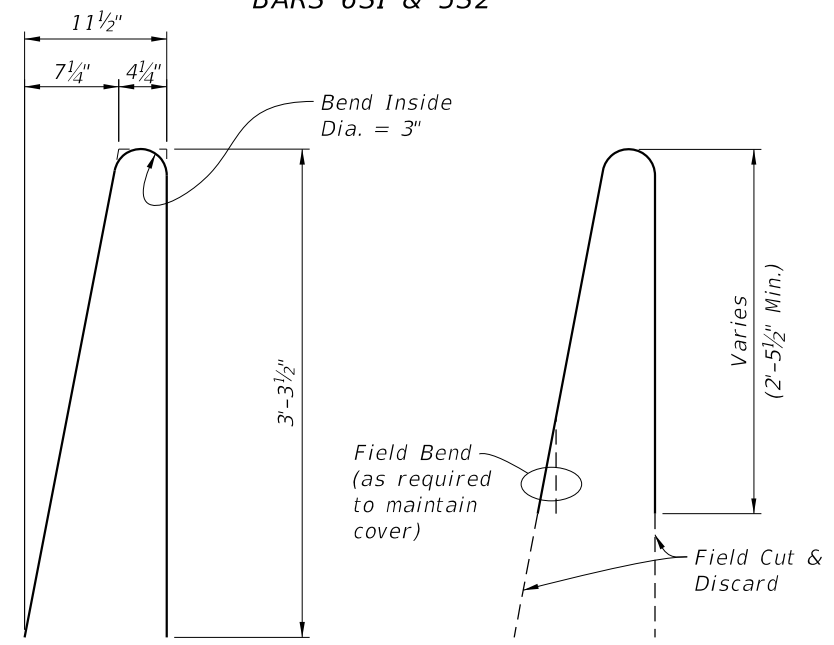

STIRRUP BAR 5P

TRANSITION STIRRUP BAR 5P
To Be Field Cut (10 of each required per Railing End Transition)

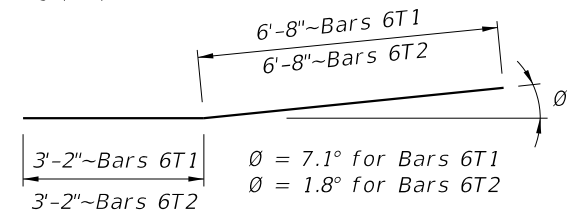

TRANSITION BARS 6T1 & 6T2
(2~Bars 6T1 & 3~Bars 6T2 required per Railing End Transition)

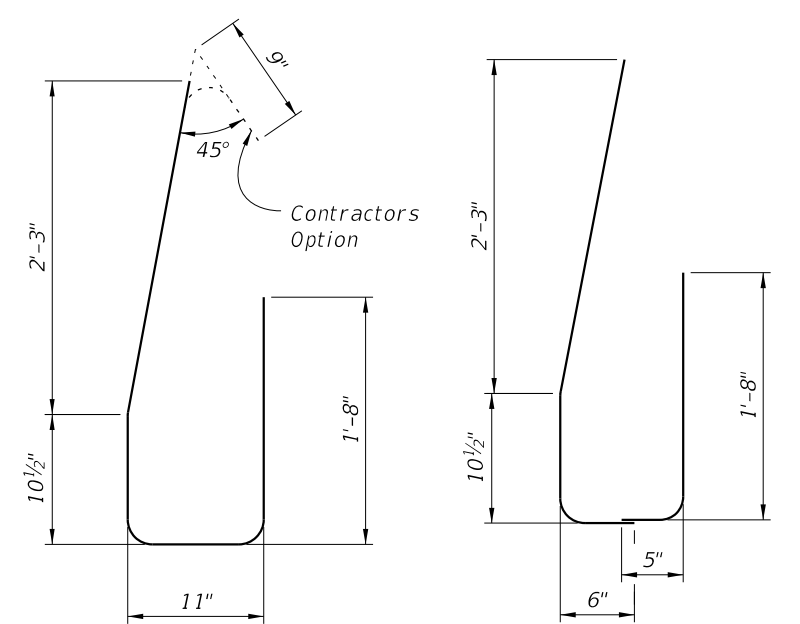

STIRRUP BAR 5V

END STIRRUP BAR 5V
To Be Field Cut and Lapped

- REINFORCING STEEL NOTES:
- All bar dimensions in the bending diagrams are out to out.
 - All reinforcing steel at the open joints shall have a 2" minimum cover.
 - Bars 6S1 may be continuous or spliced at the construction joints. Lap splices for Bars 6S1 and 5S2 shall be a minimum of 3'-0" and 2'-2", respectively.
 - The Contractor may utilize deformed WWR when approved by the Engineer. WWR must meet the requirements of Specification Section 931.

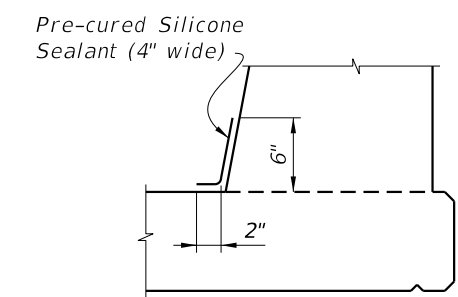

DETAIL "C" - SECTION AT INTERMEDIATE OPEN JOINT

- INTERMEDIATE JOINT SEAL NOTES:
- At Intermediate Open Joints, seal the lower 6" portion of the open joint with Pre-cured Silicone Sealant in accordance with Specification Section 932.
 - Apply sealant prior to any Class V finish coating and remove all curing compound and loose material from the surface prior to application of bonding agent.
 - The cost of the Pre-cured Silicone Sealant shall be included in the Contract Unit Price for the Traffic Railing.

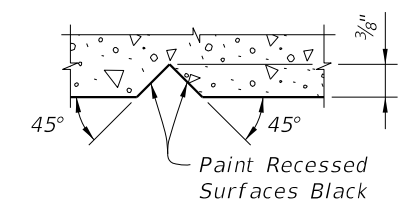

SECTION THRU RECESSED "V" GROOVE TO FORM INSCRIBED LETTERS AND FIGURES

ESTIMATED TRAFFIC RAILING QUANTITIES		
ITEM	UNIT	QUANTITY
Concrete	CY/LF	0.143
Reinforcing Steel	LB/LF	39.34

Note:
The estimated railing quantities are based on a 2% deck cross slope; railing on low side of deck.

10/16/2023 7:35:39 AM