

GENERAL NOTES:

1. For curb, gutter and curb & gutter provide $\frac{1}{8}$ " - $\frac{1}{4}$ " contraction joints at 10' centers (max.). Contraction joints adjacent to concrete pavement on tangents and flat curves are to match the pavement joints, with intermediate joints not to exceed 10' centers.
2. Locate expansion joints for curb, gutter and curb & gutter in accordance with Specification 520.

TABLE OF CONTENTS:	
Sheet	Description
1	General Notes and Contents
2	Concrete Curb and Gutter
3	Curb and Gutter Joints and Endings, Concrete Bumper Guard, and Asphaltic Concrete Curb

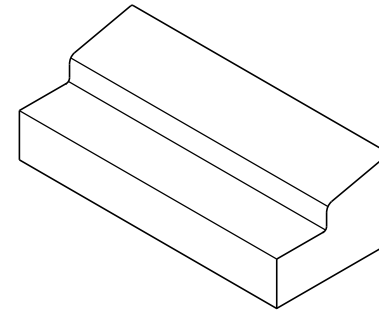

TYPE A

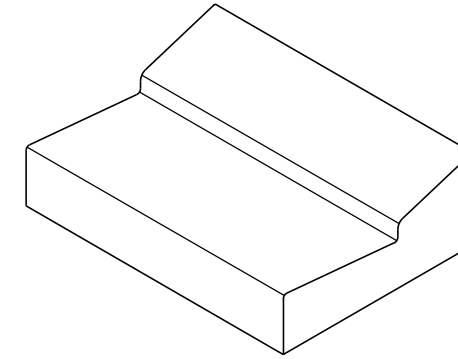

TYPE E

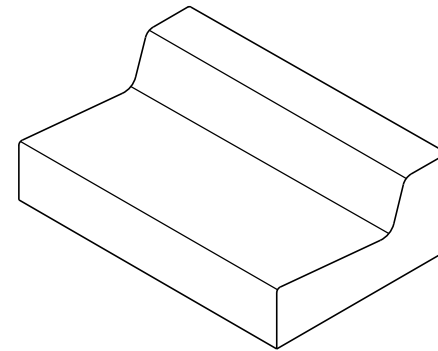

TYPE F

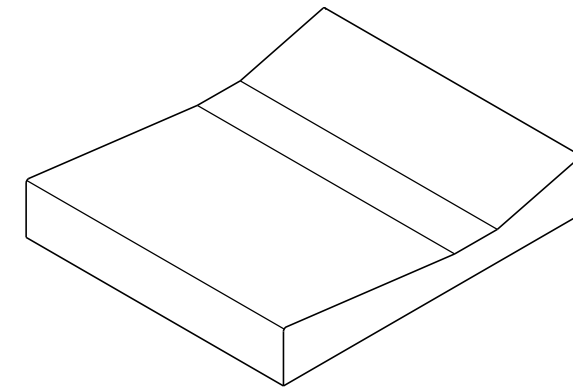

SHOULDER GUTTER

===== TYPE A, TYPE E, TYPE F, AND SHOULDER GUTTER =====
(Other Types Similar)

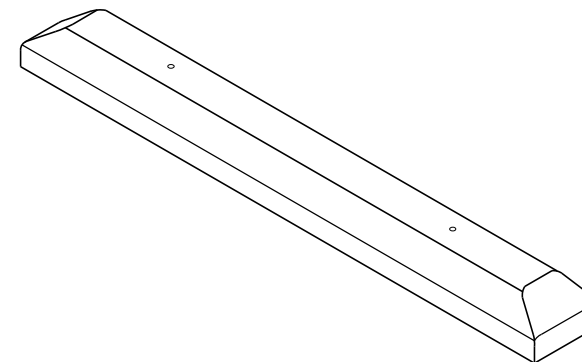

===== CONCRETE BUMPER GUARD =====

10/3/2023 12:53:02 PM

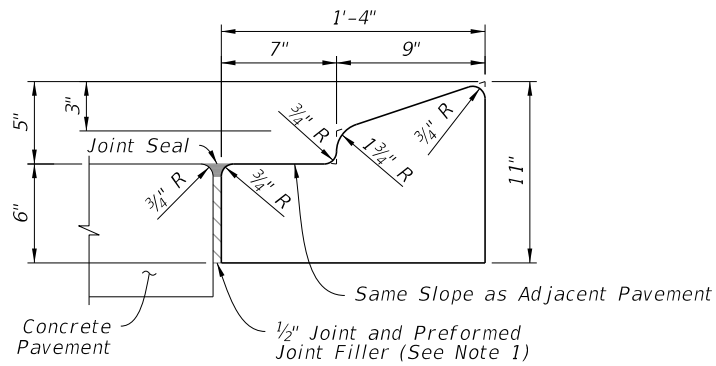

NOTE: For use adjacent to concrete or flexible pavement, concrete shown (See Note 4).

TYPE A

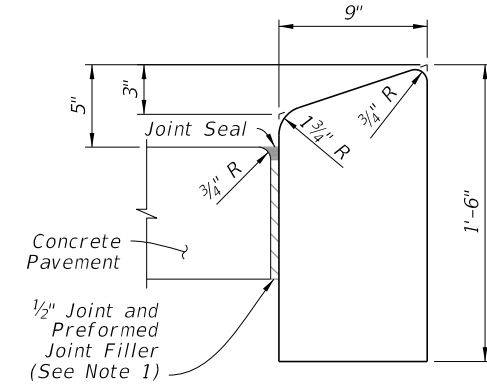

NOTE: For use adjacent to concrete or flexible pavement, concrete shown.

TYPE B

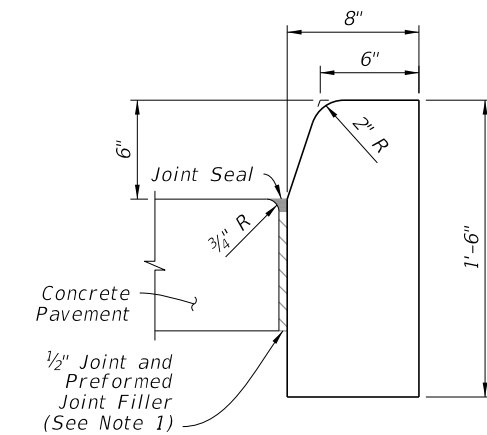

NOTE: For use adjacent to concrete or flexible pavement, concrete shown.

TYPE D

- NOTES:**
- For Type A, Type B, and Type D Curb: Expansion joint, preformed joint filler and joint seal are required between curbs and concrete pavement only, see Sheet 3.
 - For Type E, Type F, Drop Curb, and Valley Gutter: When used on high side of roadways, match the cross slope of the gutter to the cross slope of the adjacent pavement. The thickness of the lip is 6", unless otherwise shown on Plans.
 - For Type RA, rotate entire section so that gutter cross slope matches slope of adjacent circulating roadway pavement.
 - For details depicting usage of Type A Curb adjacent to flexible pavement see Sheet 3.

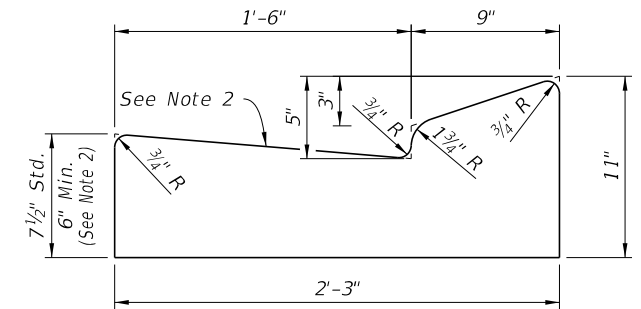

TYPE E

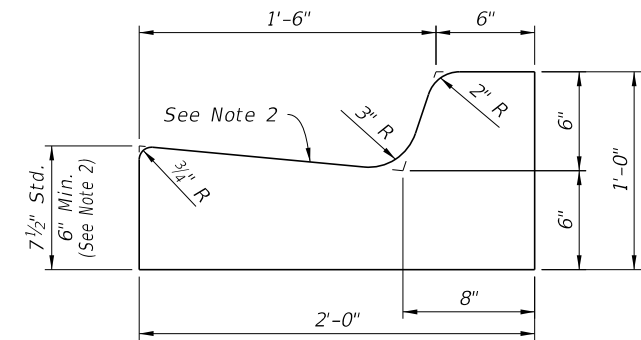

TYPE F

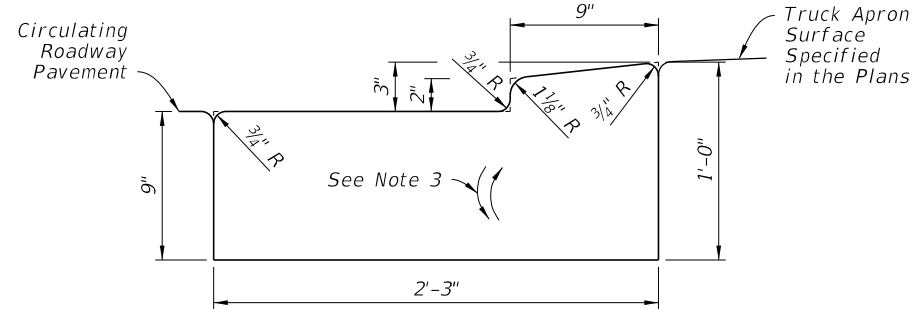

NOTE: Traffic Bearing Sections for use in Roundabout Central Island Construction.

TYPE RA

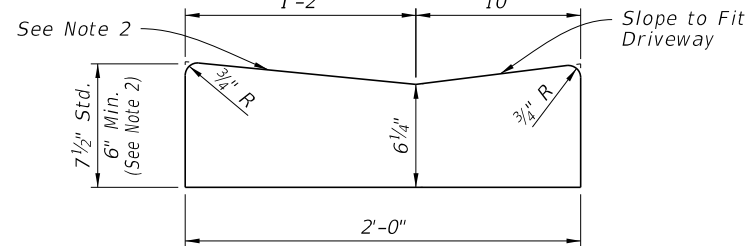

DROP CURB

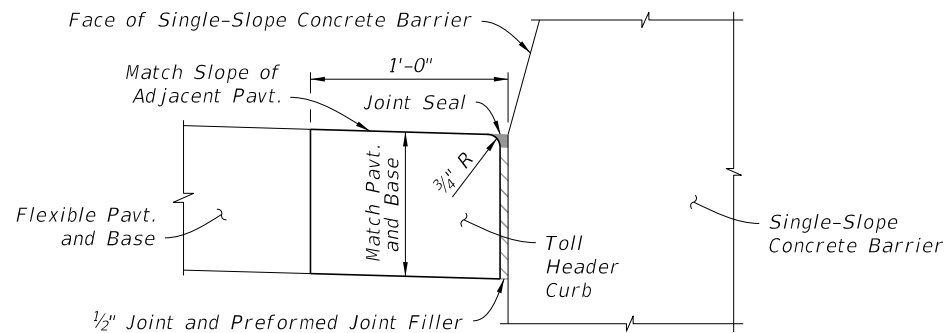

NOTE: See the toll site details for conduit requirements.

TOLL HEADER CURB

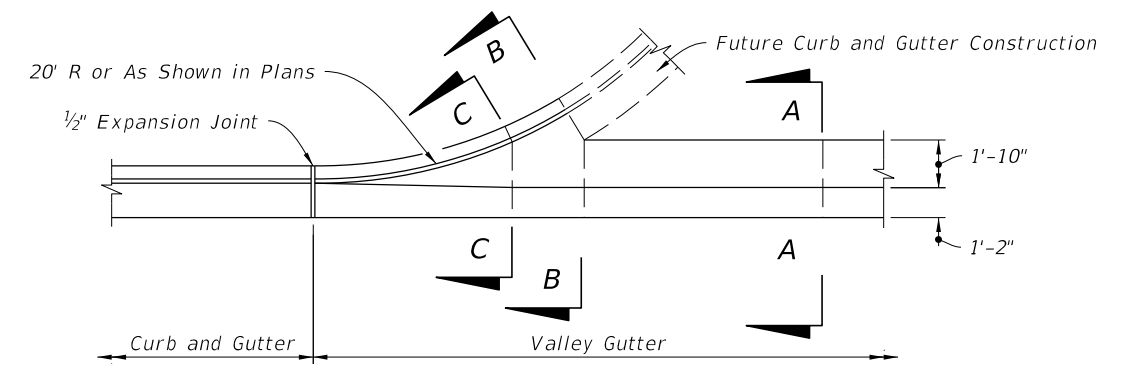

PLAN VIEW

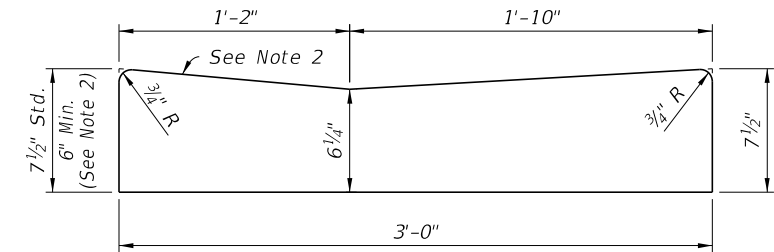

SECTION A-A

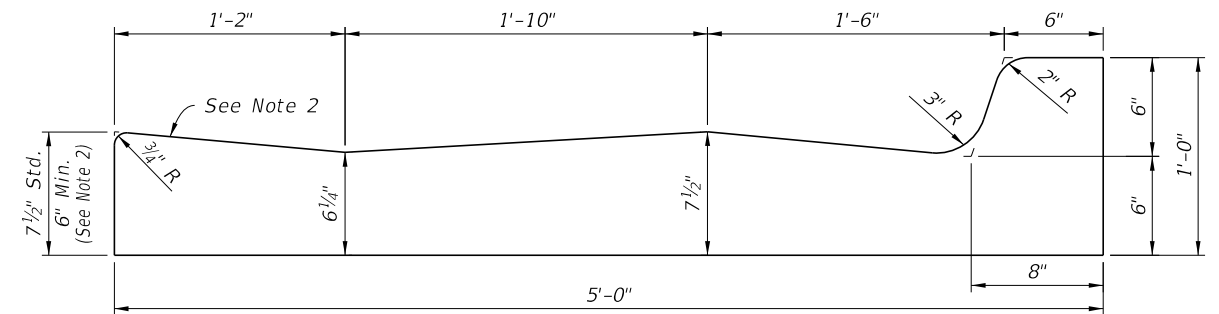

SECTION B-B

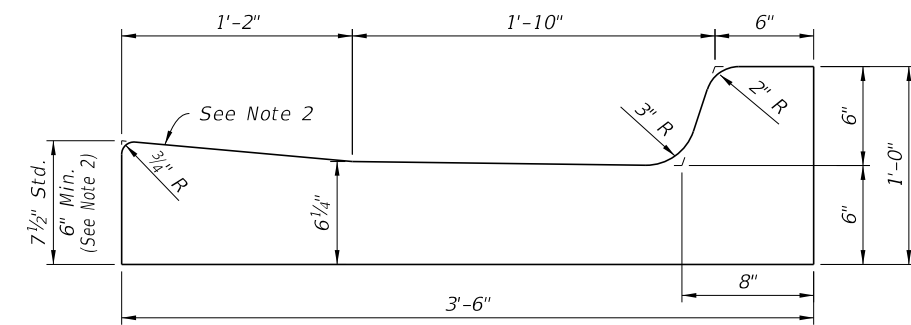

SECTION C-C

VALLEY GUTTER

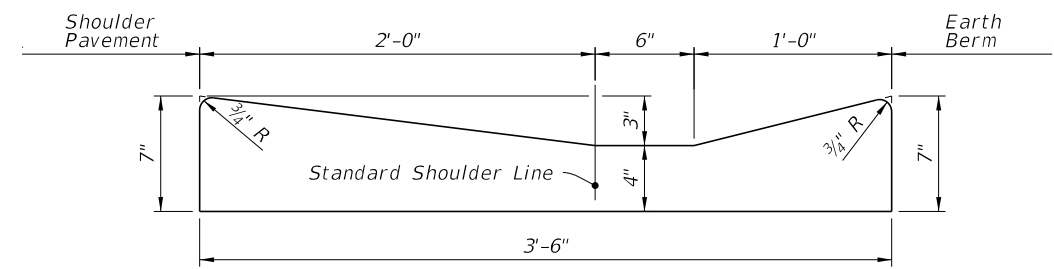

SHOULDER GUTTER

CONCRETE CURB AND GUTTER

CURB AND GUTTER

LAST REVISION	DESCRIPTION:
11/01/21	



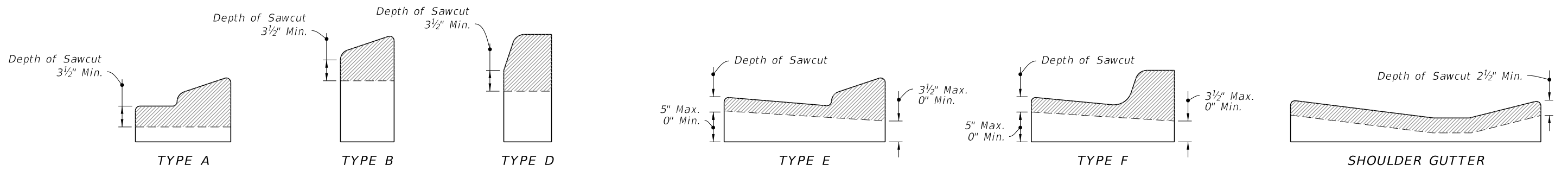

CONTRACTION JOINTS IN CURB

CONTRACTION JOINTS IN CURB & GUTTER

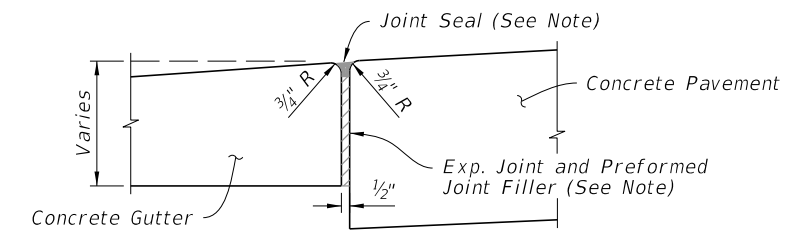
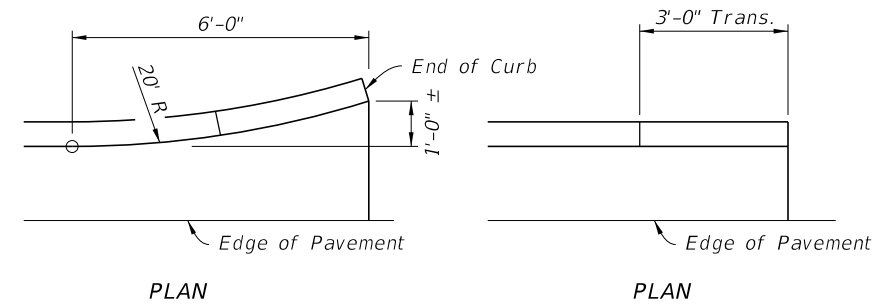
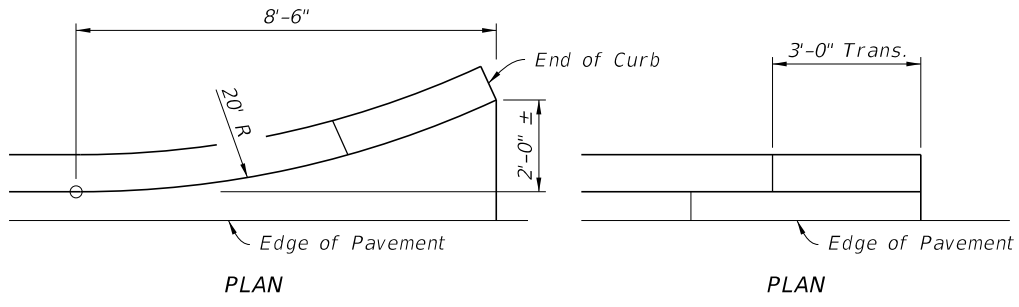

NOTE: Joint Seal application applies to both high and low sides of pavement, low side shown.

EXPANSION JOINT BETWEEN GUTTER AND CONCRETE PAVEMENT

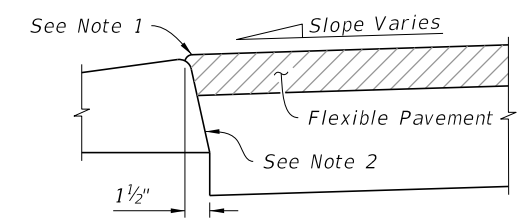
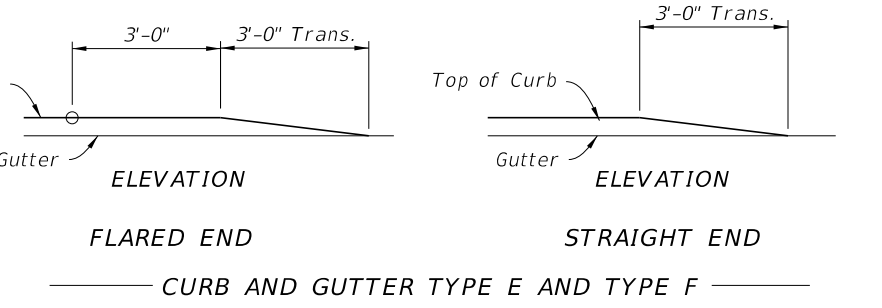
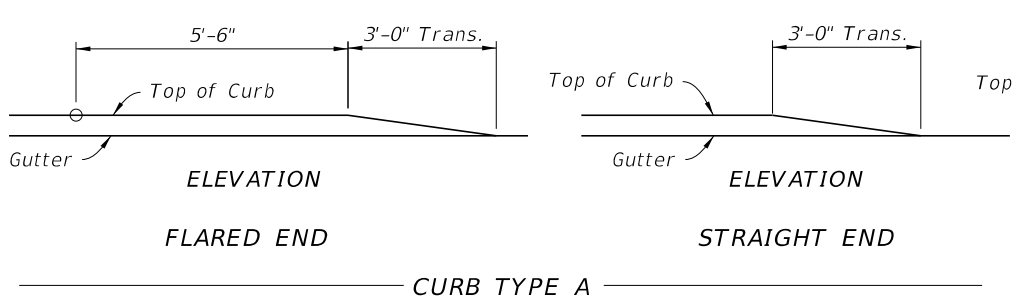

- NOTES:**
1. Surface on Low Side of Pavement to be 1/4 inch Above Lip of Gutter. Surface on High Side to be Flush With Lip of Curb or Curb & Gutter.
 2. Applies to both high and low sides of pavement, low side shown. Applies to shoulder gutter only where adjoining traffic lanes.

CURB AND CURB & GUTTER ENDINGS

CURB AND GUTTER AND TYPE A CURB ADJACENT TO FLEXIBLE PAVEMENT

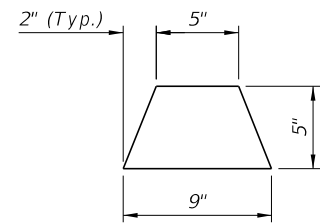
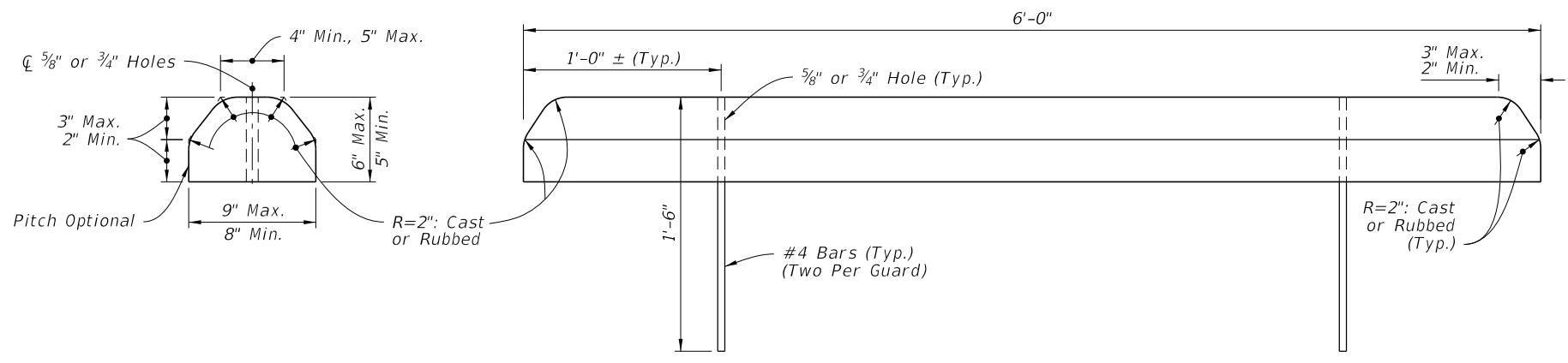

CONCRETE BUMPER GUARD

ASPHALTIC CONCRETE CURB

CURB AND GUTTER JOINTS AND ENDINGS, CONCRETE BUMPER GUARD, AND ASPHALTIC CONCRETE CURB

10/3/2023 12:53:16 PM

LAST REVISION 11/01/21	REVISION	DESCRIPTION:		FY 2024-25 STANDARD PLANS	CURB AND GUTTER	INDEX	SHEET
						520-001	3 of 3