

TRAFFIC RAILING RETROFIT NOTES

See Index 536-001 for component details, geometric layouts and associated notes not fully detailed herein.

CONCRETE: Concrete for Transition Blocks shall be Class II (Bridge Deck).

THRIE-BEAM PANEL: Steel Thrie-Beam Elements shall meet the requirements for Class B (10 Gauge) Guardrail of AASHTO M 180, Type II (Zinc coated). The minimum panel length for Thrie-Beam Elements shall be 12'-6". Field drilled holes for Post connections shall be 3/4" by 2 1/2" slotted holes.

BOLTS, NUTS AND WASHERS: Bolts, nuts and round washers shall be in accordance with AASHTO M180. Plate Washers shall be in accordance with ASTM A36 or ASTM A709 Grade 36.

COATINGS: All Nuts, Bolts, Anchors, and Washers shall be hot-dip galvanized in accordance with the Specifications.

BRIDGES ON CURVED ALIGNMENTS: The details presented herein are shown for bridges on tangent alignments. Details for bridges on horizontally curved alignments are similar.

THRIE-BEAM EXPANSION SECTION: Thrie-Beam Expansion Sections shall be installed at locations shown in the Plans. Install nuts for splice bolts finger-tight at 2 1/2" slots in thrie-beam expansion sections. Nuts shall fully engage bolts with a minimum of one bolt thread extending beyond the nuts. Distort the first thread on the outside of the nut to prevent loosening. Tighten bolts in 3 3/4" slots at guardrail post(s) that lie between the slotted expansion splice and bridge deck joint so that the bolt heads are in full contact with thrie-beam elements, but not so tight as to impede movement due to expansion.

WOOD BLOCKS: All wood blocks, including required wedge shaped blocks shall be Pressure Treated Lumber in accordance with Specifications Section 955. Bolt holes in blocks to be centered (±1/4").

BRIDGE NAME PLATE: If a portion of the existing Traffic Railing is to be removed that carries the bridge name, number and or date, or if the installation of the Traffic Railing (Thrie-Beam Retrofit) will obscure the bridge name, number and or date, then replace the information that has been removed or obscured, with 3" tall black lettering on white nonreflective sheeting applied to the top of the adjacent guardrail. The information must be clearly visible from the right side of the approaching travel lane. The sheeting and adhesive backing shall comply with Specification Section 994 and may comprise of individual decals of letters and numbers.

PAYMENT: Payment will be made under Thrie-Beam Panel Retrofit which shall include all materials and labor required to fabricate and install the retrofit railing. Transition Blocks and Curbs, Bridge Name Plate and Barrier Delineators, where required, will not be paid for directly but shall be considered incidental work.

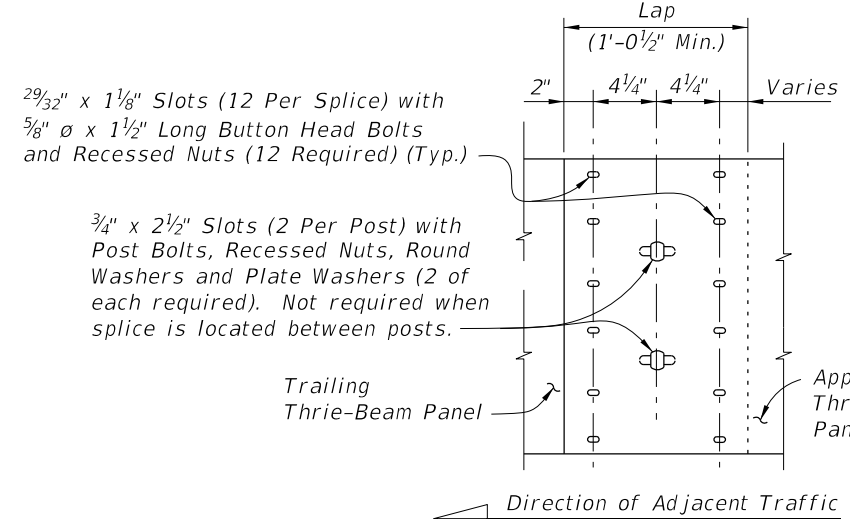

THRIE-BEAM PANEL SPLICE

NOTE: All Thrie Beam Panels shall be lapped in the direction of adjacent traffic. At the Contractor's option, laps may be extended. Field drill holes in Trailing Thrie-Beam Panel as required.

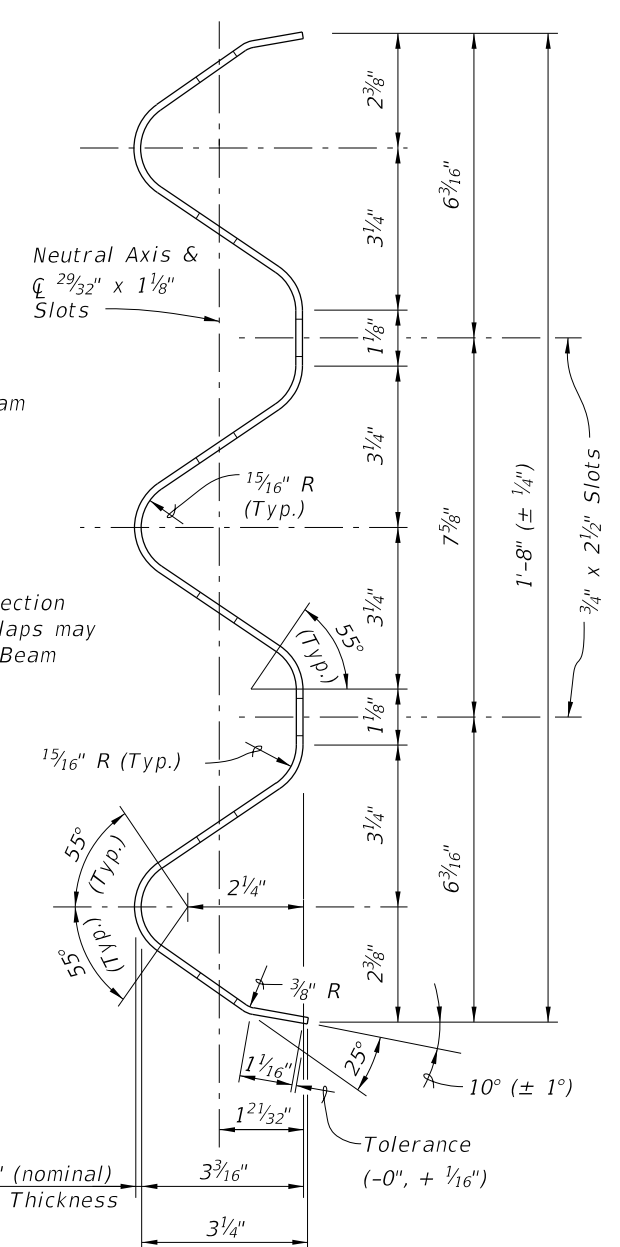

TYPICAL SECTION THRU CLASS B (10 GAUGE) THRIE-BEAM PANEL (EXPANSION SECTION SIMILAR)

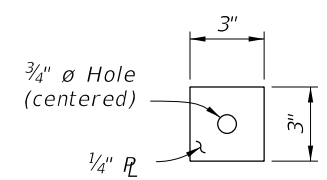
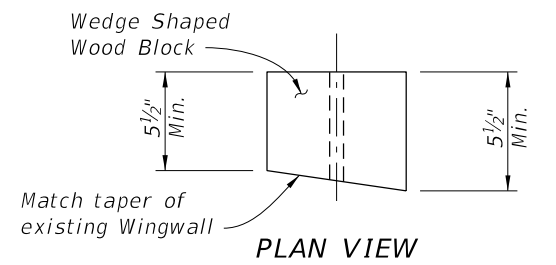
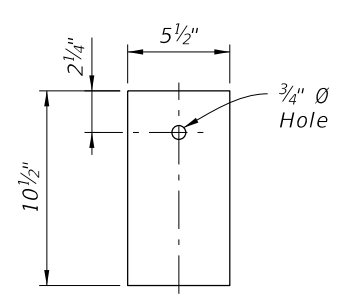

PLATE WASHER DETAIL



PLAN VIEW



1" WOOD BLOCK

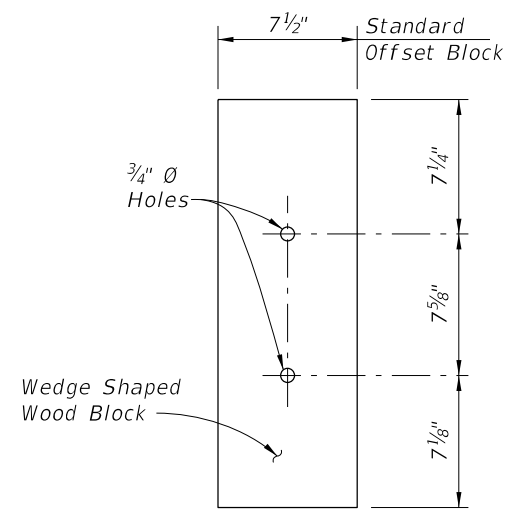

FRONT VIEW WEDGE SHAPED BLOCK DETAIL

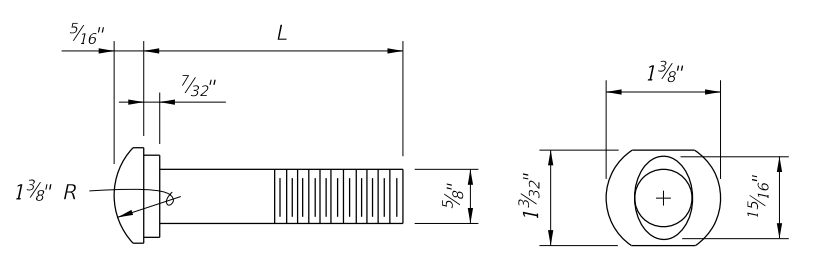

5/8" OVAL SHOULDER BUTTON HEAD BOLT

| L (in) | THREAD LENGTH (in) | APPLICATION |
|--------|--------------------|-------------|
| 1 1/2 | Full Length | Splice Bolt |
| 14 | 4 | Post Bolt |

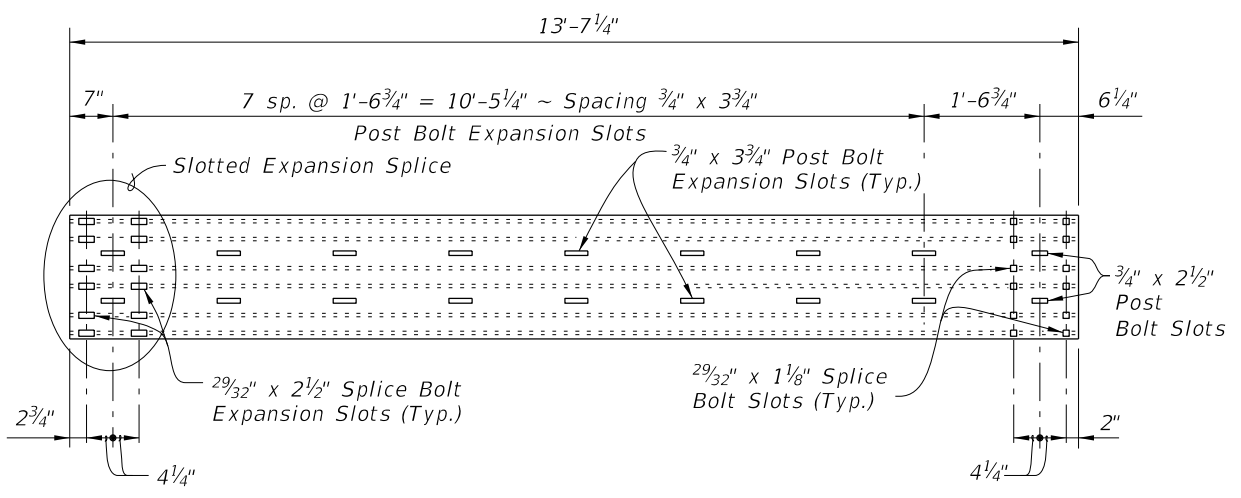

THRIE-BEAM EXPANSION SECTION

10/16/2023 7:13:23 AM

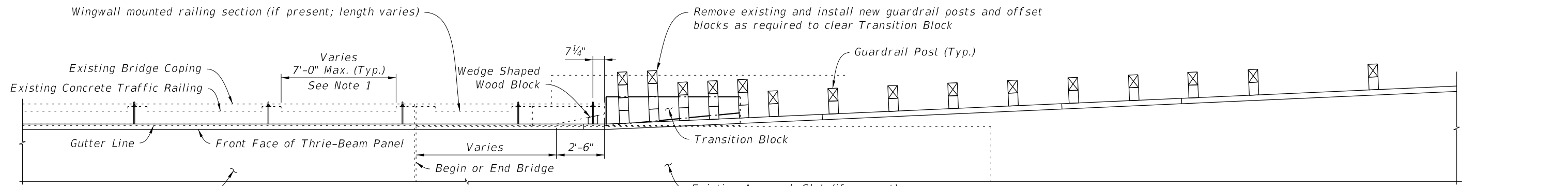

PARTIAL PLAN - APPROACH TRANSITION

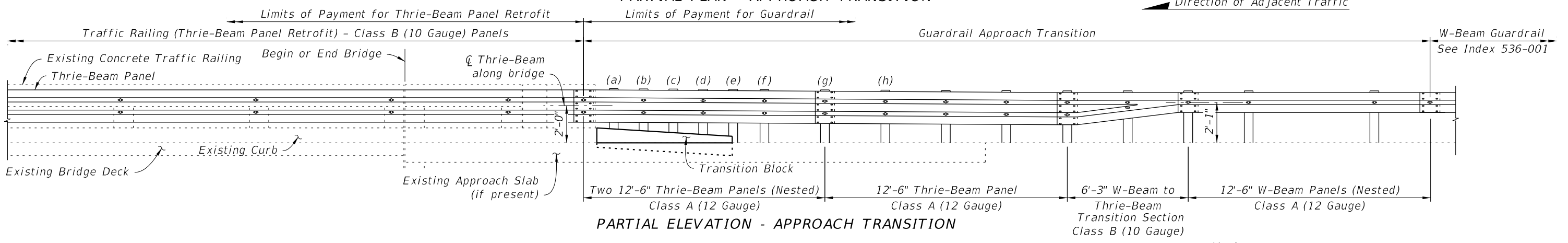

PARTIAL ELEVATION - APPROACH TRANSITION

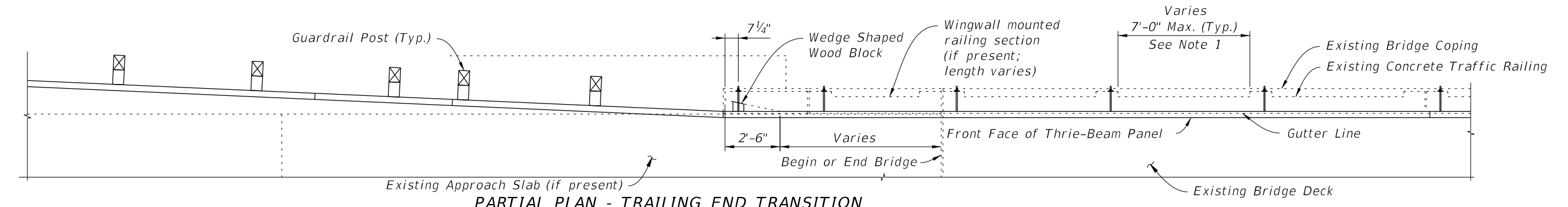

PARTIAL PLAN - TRAILING END TRANSITION

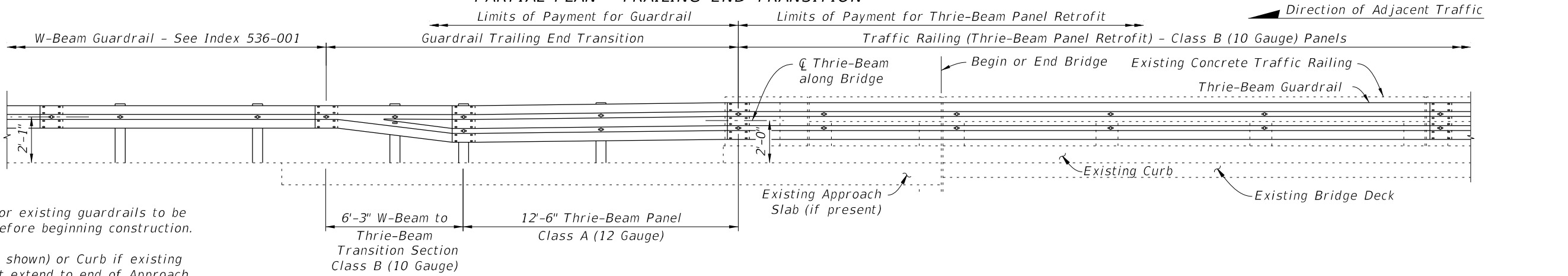

PARTIAL ELEVATION - TRAILING END TRANSITION

- NOTES:
1. Dimensions and elevations for existing guardrails to be verified by the Contractor before beginning construction.
 2. Provide Transition Block (as shown) or Curb if existing Approach Slab Curb does not extend to end of Approach Slab. Shape and height of the traffic face of Transition Block or Curb shall match existing bridge curb. See Sheet 4 for Transition Block details. Block may be omitted on trailing ends with no opposing traffic.
 3. Do not bolt nested rails to the blocks and posts at posts (a), (c) & (e).

10/18/2023 9:11:14 AM

| | | | | | | | |
|---------------------------|----------|--------------|--|------------------------------|--|------------------|-----------------|
| LAST REVISION 01/01/14 | REVISION | DESCRIPTION: |  | FY 2024-25 STANDARD PLANS | THRIE-BEAM PANEL RETROFIT (CONCRETE HANDRAIL) | INDEX 460-477 | SHEET 2 of 4 |
|---------------------------|----------|--------------|--|------------------------------|--|------------------|-----------------|

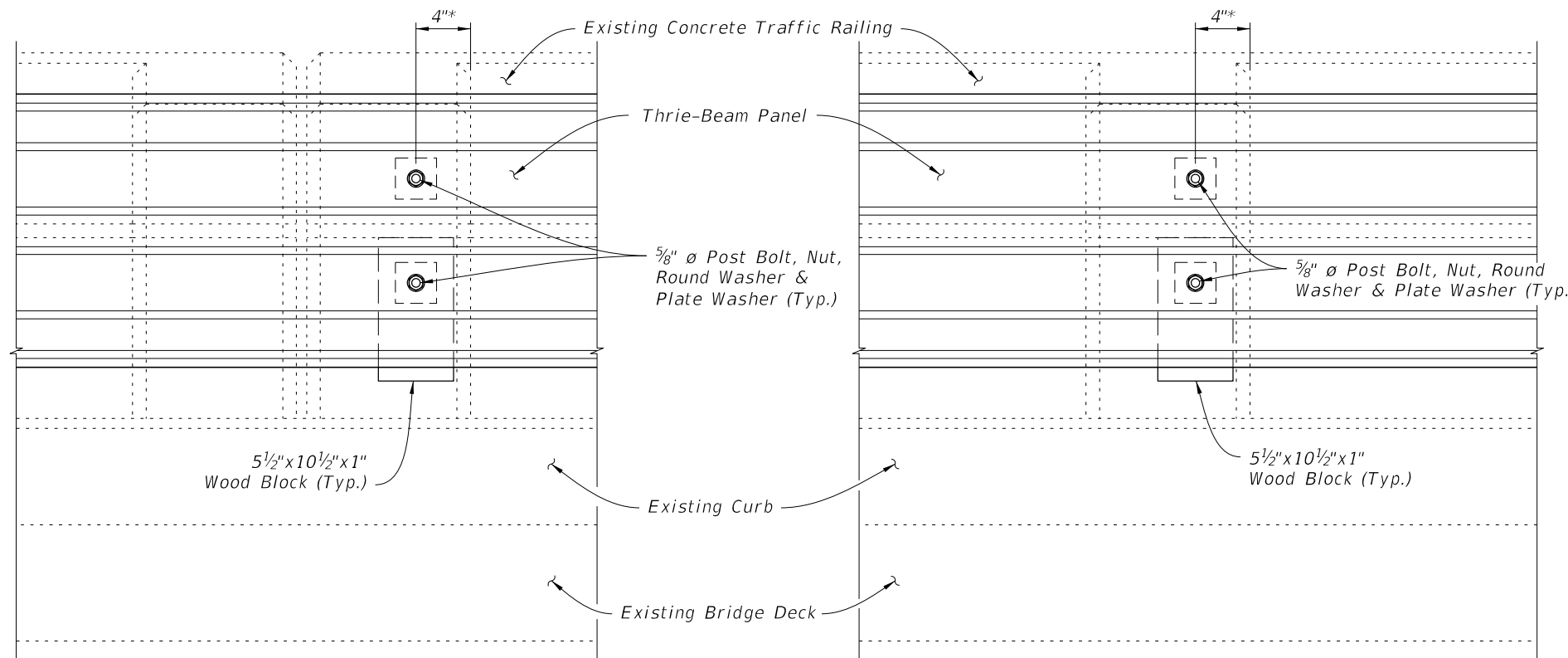

**ELEVATION VIEW A-A
(At Double Posts)**

(View at Intermediate Double Posts shown;
View at Expansion Joints similar)

**ELEVATION VIEW A-A
(At Single Post)**

* Measured from edge of existing Post. Bolts may be installed at either side of any Post.

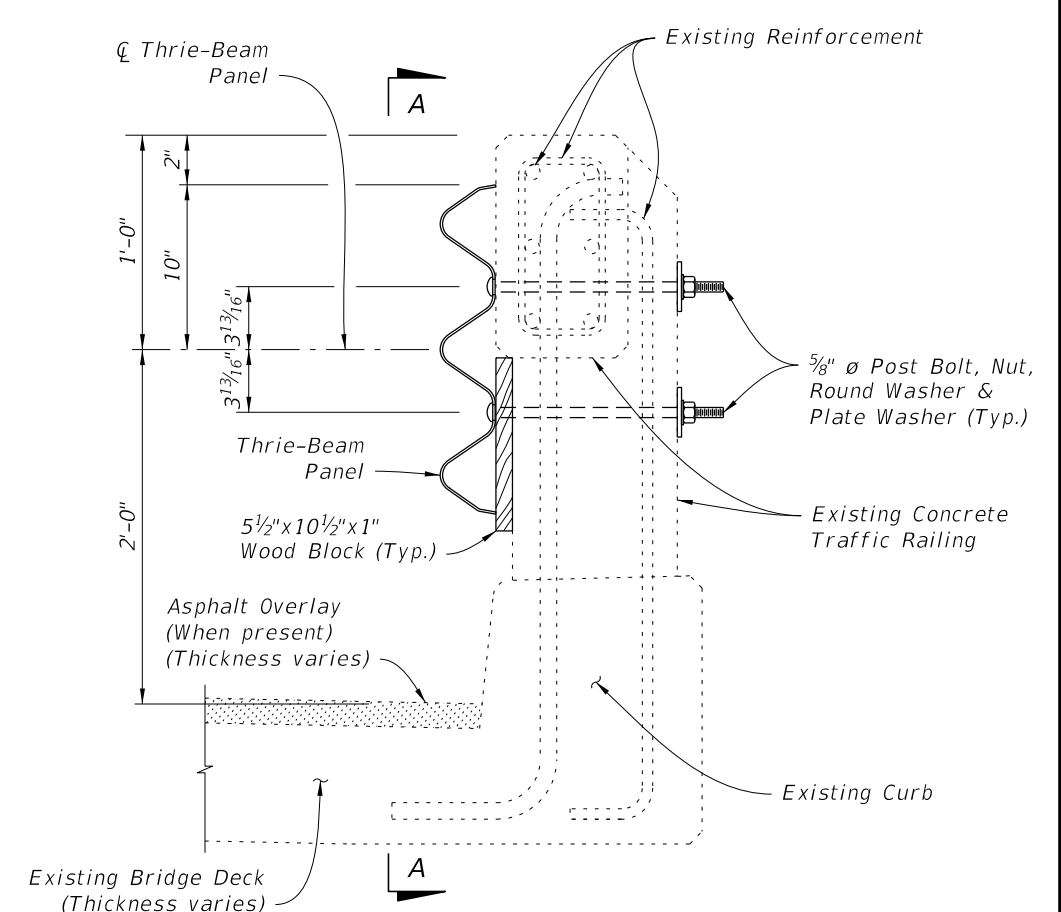

TYPICAL SECTION THRU RAILING POST ON BRIDGE DECK

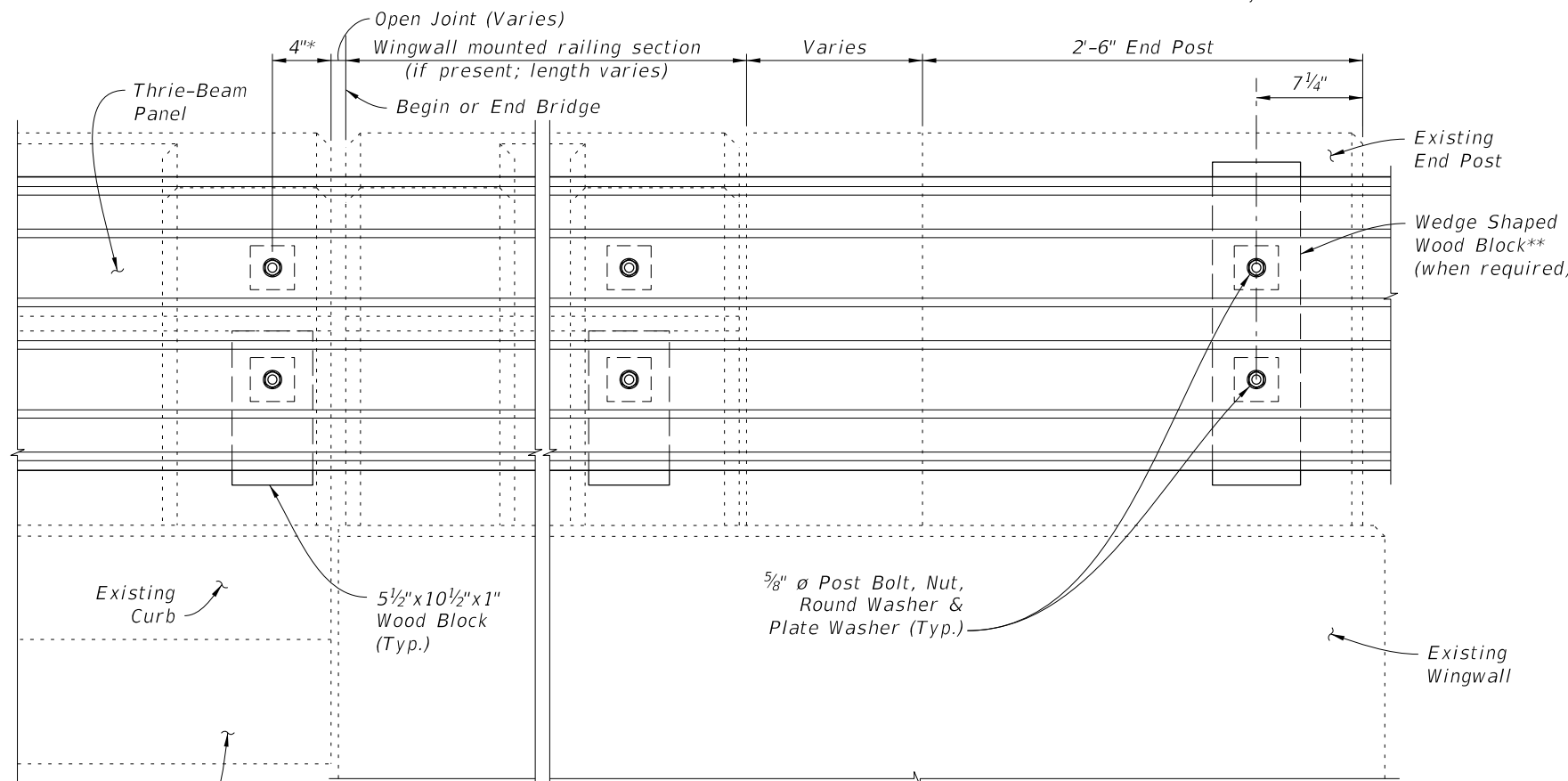

**ELEVATION VIEW A-A
(At End Post)**

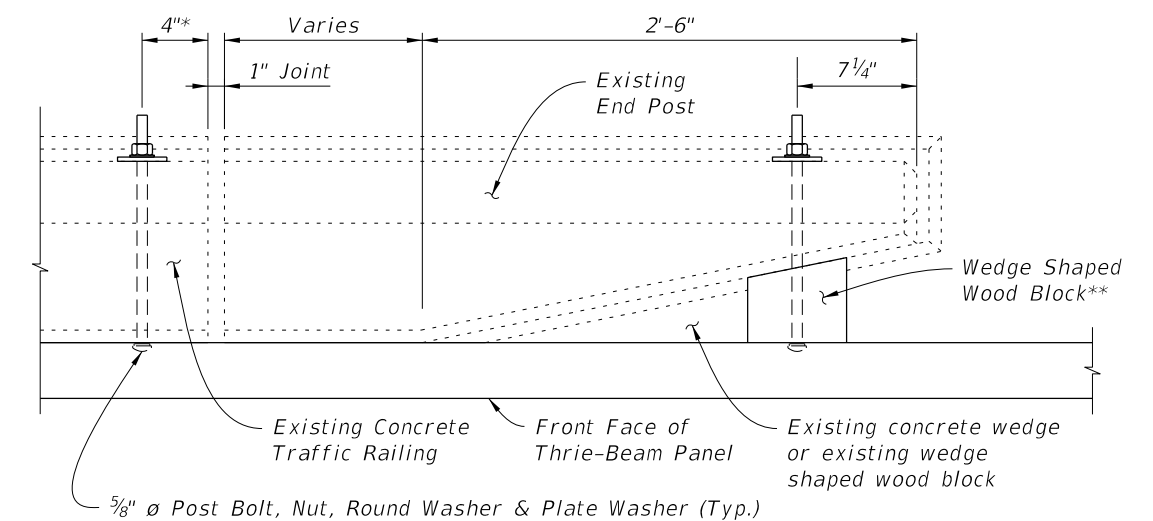

PLAN OF END POST

** For End Posts with an existing wedge shaped wood block, remove existing wood block and replace with new Wedge Shaped Wood Block (See Sheet 1 for notes and details).

NOTES:

1. Post Bolts shall be $\frac{5}{8}$ " ϕ x 14" long set in $\frac{7}{8}$ " ϕ core drilled holes, see Sheet No. 1.
2. Shift Post Bolt holes minimally inward toward center of posts if existing reinforcement is encountered during drilling of holes. If reinforcement is still encountered, notify the Engineer before proceeding with drilling.
3. Post Bolt spacing not to exceed 8'-0" (\pm 1").

10/16/2023 7:13:44 AM

| | |
|---------------------------|--------------|
| LAST REVISION 07/01/13 | DESCRIPTION: |
|---------------------------|--------------|



FY 2024-25
STANDARD PLANS

THRIE-BEAM PANEL RETROFIT
(CONCRETE HANDRAIL)

INDEX
460-477

SHEET
3 of 4

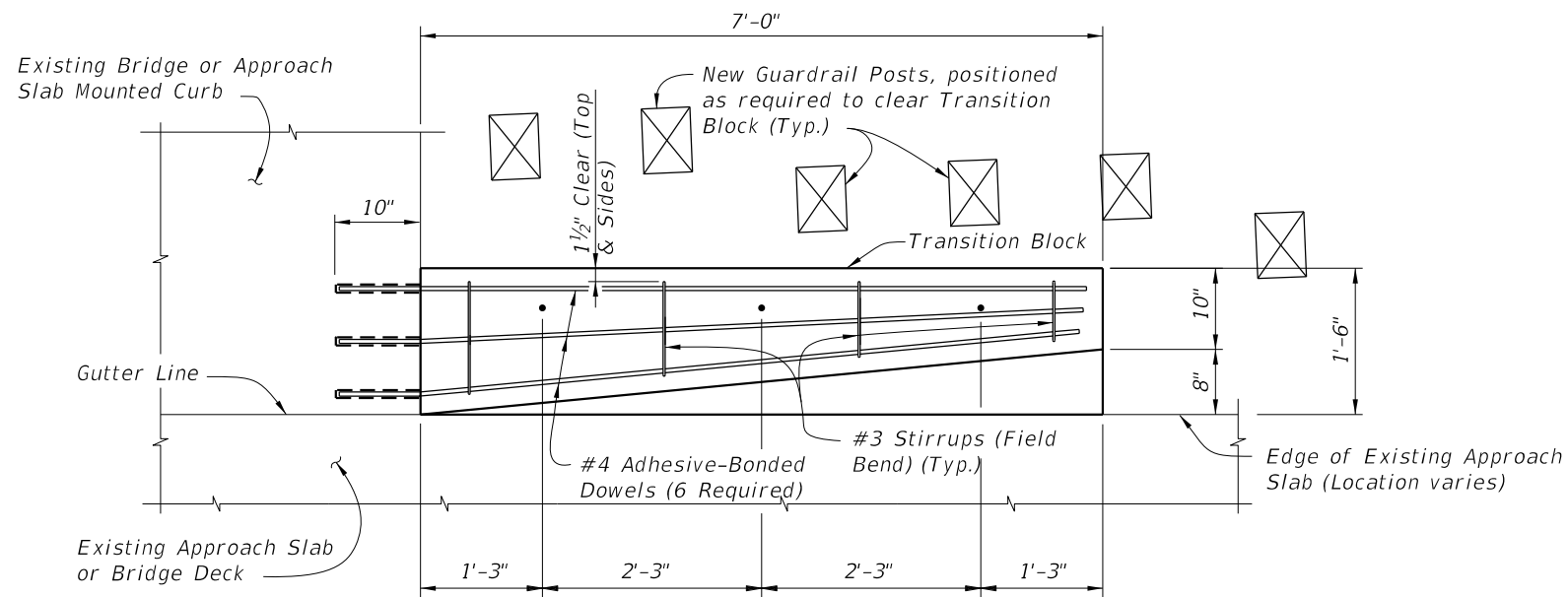

PLAN VIEW OF TRANSITION BLOCK
(GUARDRAIL NOT SHOWN FOR CLARITY)

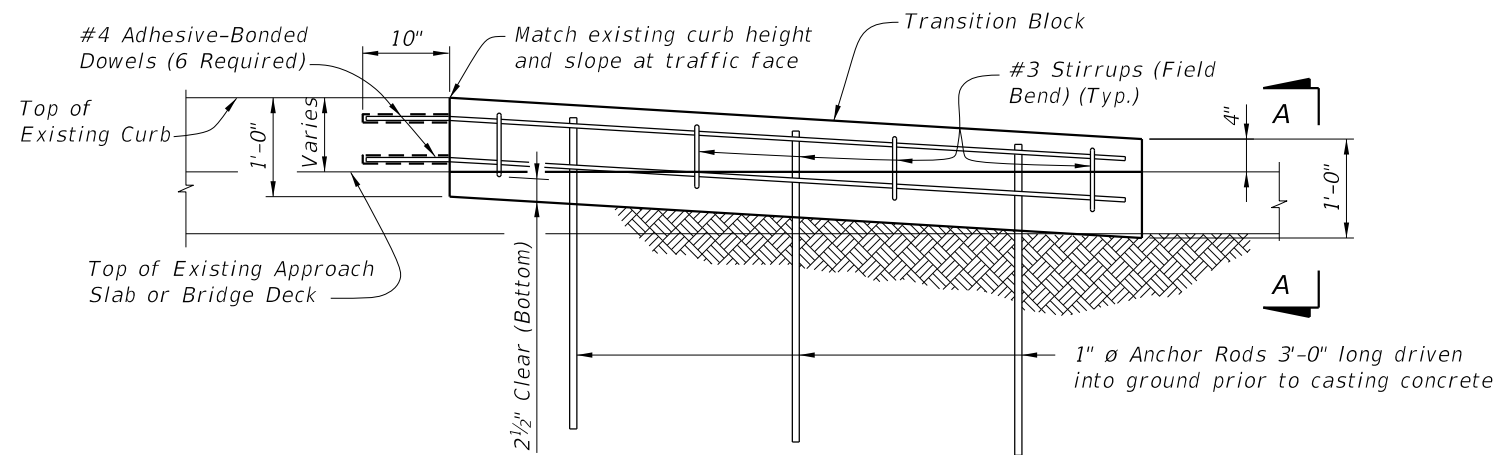

ELEVATION OF TRANSITION BLOCK
(GUARDRAIL AND POSTS NOT SHOWN FOR CLARITY)

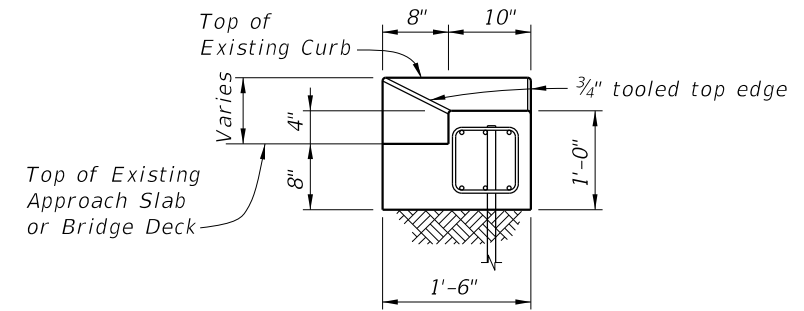

END VIEW A-A

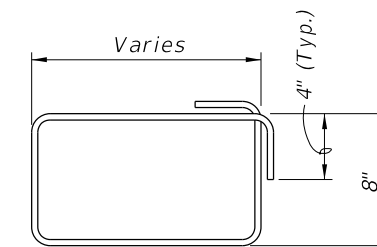

#3 STIRRUP (FIELD BEND)

NOTES:

ANCHOR RODS: Steel Anchor Rods shall be ASTM A36, ASTM A709 Grade 36 or ASTM A615 Grade 60 hot-dip galvanized in accordance with Specification Section 962.

ADHESIVE-BONDED DOWELS: Adhesive Bonding Material Systems for Dowels shall comply with Specification Section 937 (Type HV) and be installed in accordance with Specification Section 416.

Adhesive Bonded Dowels are shown installed in an existing curb or sidewalk integrally reinforced with Approach Slab, Wingwall or Bridge Deck. For installations in existing detached curbs or sidewalks, install dowels in available sound concrete.

Shift bars (as needed) to install six dowels into existing bridge or approach slab mounted curb.

| ESTIMATED QUANTITIES PER TRANSITION BLOCK | | |
|---|------|----------|
| ITEM | UNIT | QUANTITY |
| Concrete Class II (Bridge Deck) | CY | 0.4 |
| Reinforcing Steel | LB | 61 |
| Guardrail (Reset) | LF | 12.5 |

10/16/2023 7:13:55 AM