

*The 45" Ø Void in the pile shall be positively vented to water or air after the final pile installation. If the 3½" Ø vents are included in the pile cut-off section, then venting shall be provided by the use of a 1" Ø PVC conduit through the substructure cap or column.

ELEVATION

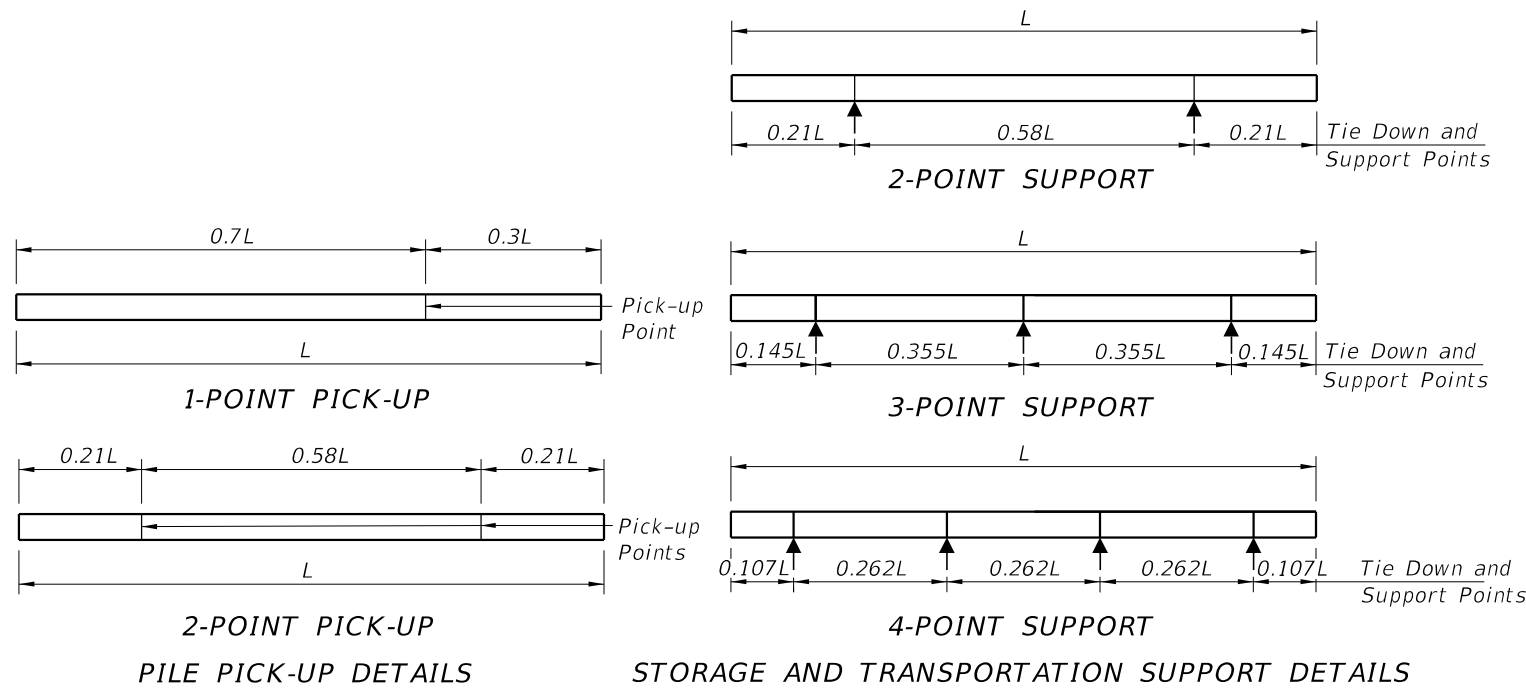

NOTES

- Work this Index with the Pile Data Table in the Structures Plans.
- Concrete:
 - Piles: Class V
 - Splice Collar: Class IV
 - See "GENERAL NOTES" in the Structures Plans for locations where the use of Highly Reactive Pozzolans is required.
- Concrete Strength at time of prestress transfer:
 - Piles: 4,000 psi minimum.
- Carbon-Steel Reinforcing:
 - Bars: Meet the requirements of Specification Section 415
 - Prestressing Strands: Use 0.6 dia. carbon-steel, Grade 270, low-relaxation strand stressed to 44.0 kips that meets the requirements of Specification Section 933.
 - Protect all carbon-steel strands permanently exposed to the environment and not embedded under final conditions in accordance with Specification Section 450.
- Spiral Ties:
 - One half turn is required for carbon-steel spiral splices
 - One full turn is required at the head and tip of each pile
- Pile Splices:
 - Epoxy: Type AB Epoxy Compound or Epoxy Mortar must meet the requirements of Specification Section 926.
 - Use a Type AB Epoxy Bonding Compound or Epoxy Mortar, as recommended by the Manufacturer, to form the joint between pile sections.
 - Use a Type AB Epoxy Bonding Compound as a bonding agent on internal pile surfaces.
 - Splices: Resume pile driving after the splice concrete reaches a minimum strength of 5,500 psi.
- Mark piles at the pick-up points to indicate the proper points for attaching handling lines.

TABLE OF MAXIMUM PILE PICK-UP AND SUPPORT LENGTHS		
Maximum Pile Length (Feet)	Required Storage and Transportation Detail	Pick-Up Detail
122	2, 3, or 4 point	1 Point
174	2, 3, or 4 point	2 Point

10/15/2023 11:52:06 AM

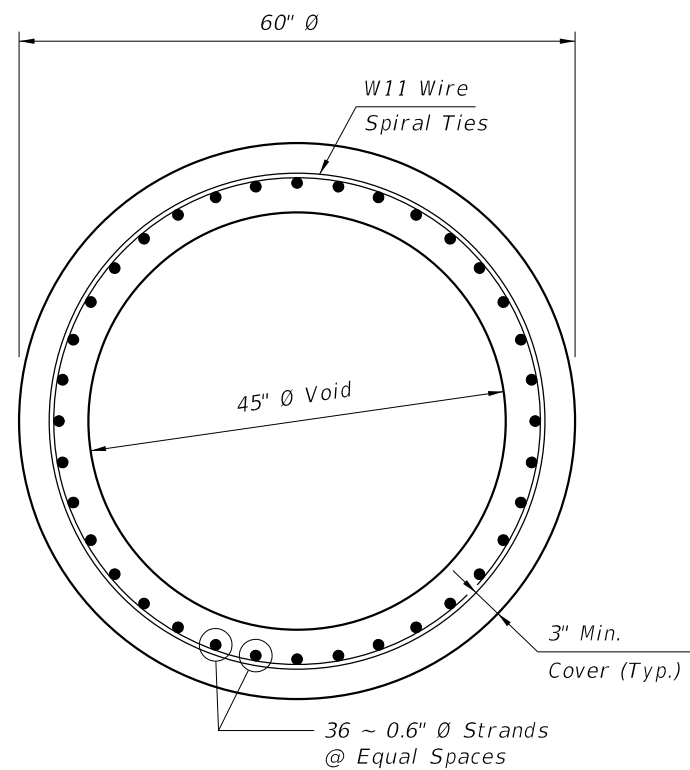
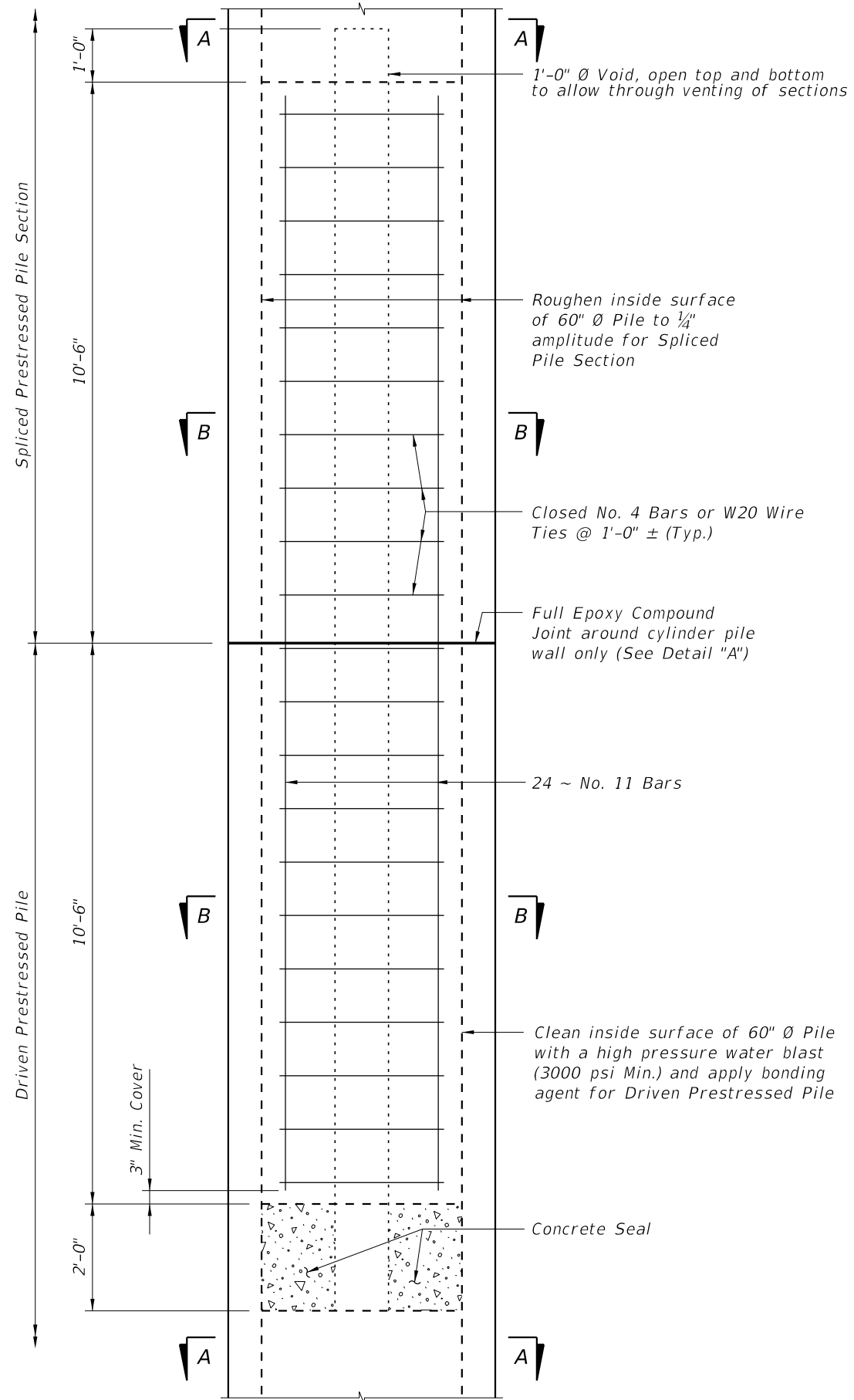

SECTION A-A

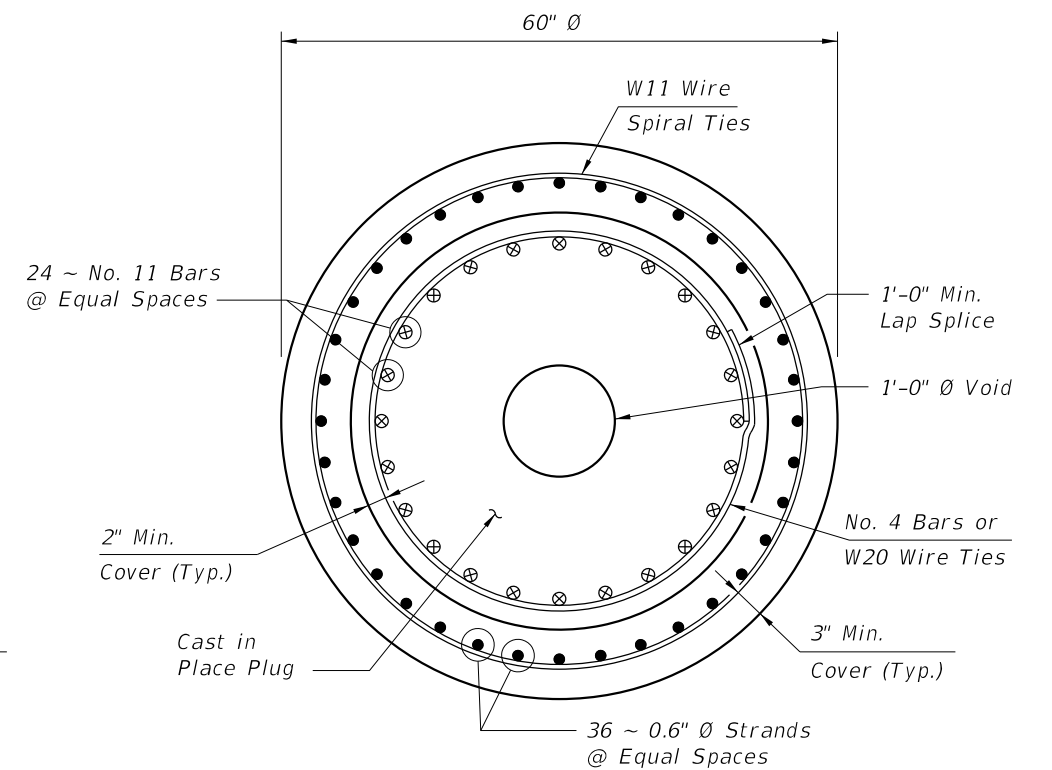

SECTION B-B

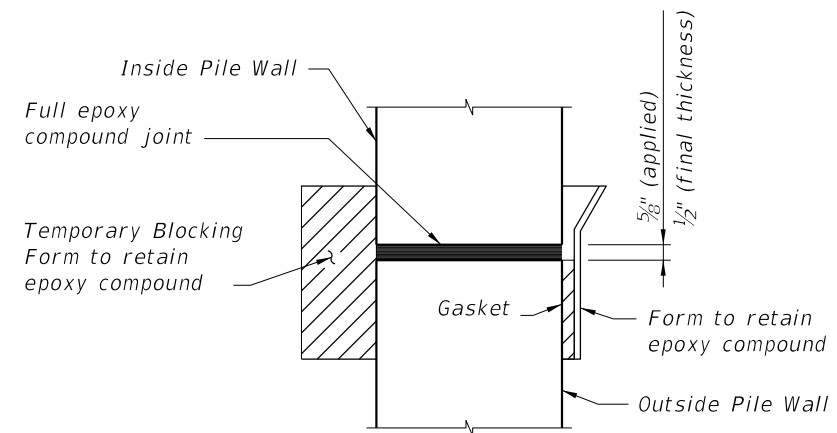

DETAIL "A"

DRIVABLE UNFORESEEN FIELD SPLICE DETAIL
(Cast in Place Plug)

10/15/2023 11:52:14 AM

LAST REVISION 01/01/12	DESCRIPTION:		FY 2024-25 STANDARD PLANS	60" PRESTRESSED CONCRETE CYLINDER PILE	INDEX 455-060	SHEET 2 of 2
REVISION						