

**PLAN**  
(FIB Skewed Alignment Shown, Skew = 0° and AASHTO Type II Similar)

**BEVELED BEARING PLATE B**  
(Along  $\bar{C}$  Beam)  
(Positive Slope shown;  
Negative Slope similar)

- LEGEND:**
- \* 1/2" for Pad Type K
  - \*\* 4" for Pad Type K at End 1
  - \*\*\* 4" for Pad Type K at End 2

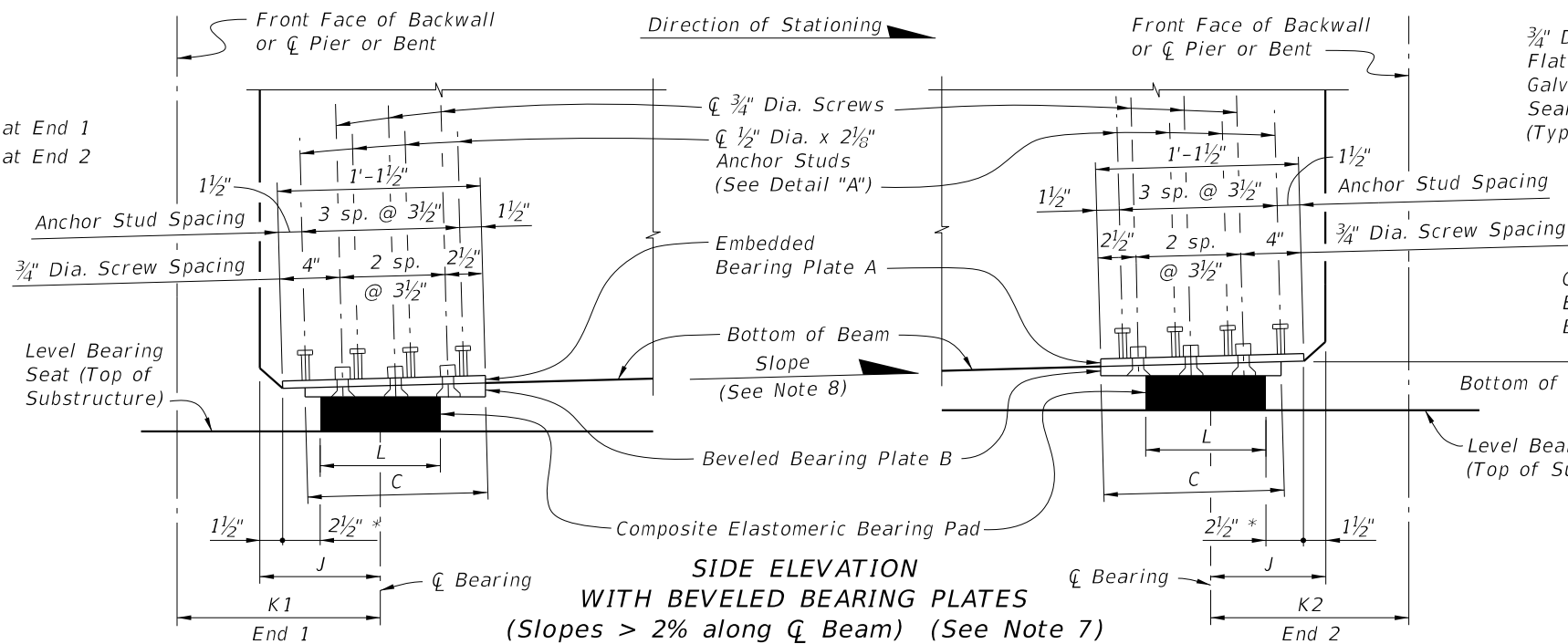

**SIDE ELEVATION**  
WITH BEVELED BEARING PLATES  
(Slopes > 2% along  $\bar{C}$  Beam) (See Note 7)

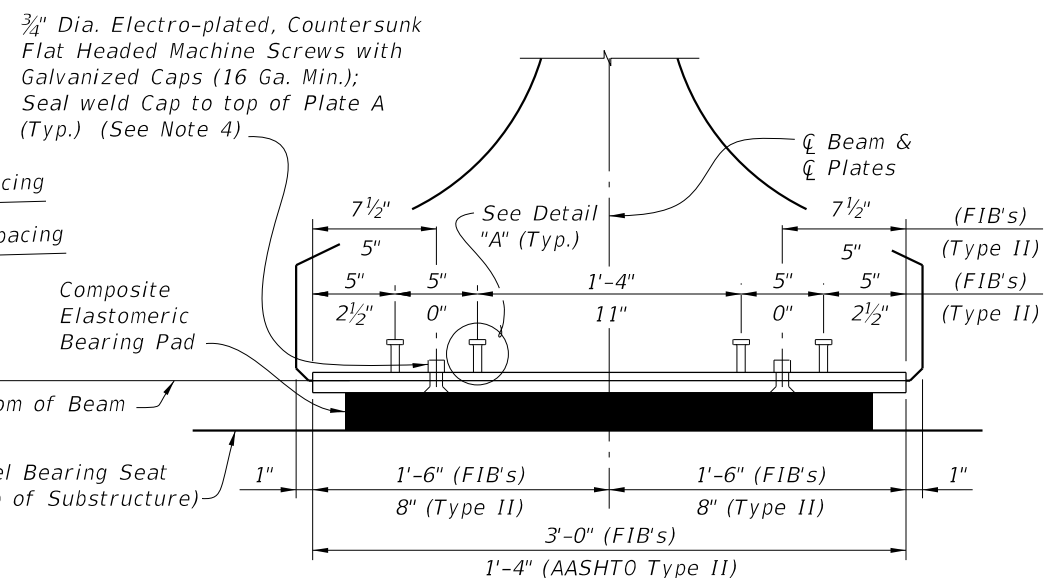

**END ELEVATION**  
WITH BEVELED BEARING PLATE

**NOTES:**

1. Work this sheet with Index 400-510 - Composite Elastomeric Bearing Pads, and 'BEARING PLATE DATA TABLE' in the Structures Plans.
2. Embedded Bearing Plates A are required for all Florida-I beams. Beveled Bearing Plates B with Embedded Bearing Plates A are required for beams as scheduled in the 'BEARING PLATE DATA TABLE' in the Structures Plans.
3. Bearing plate material shall conform to ASTM A36 or ASTM A709 (Grade 36 or 50). Headed Concrete Anchor Studs shall conform to Specification Section 502. Hot-dip galvanize Bearing Plates A & B after fabrication except that Galvanized Caps may be welded in place after hot-dip galvanizing. Drill Bearing Plates A and B as an assembled unit, thread Bearing Plate A only. Holes are not required in Plate A when Plate B is not required. Drill and thread holes perpendicular to Embedded Plate A and prior to plates being galvanized (ASTM A 123).
4. Provide Electroplated, Flat Head Cap Screws in accordance with ASTM F 835. Electroplating shall be ASTM B633, SC 2, Type 1. Provide screws long enough to maintain a 3/4" minimum embedment into Embedded Bearing Plate A and Galvanized Cap. Provide steel Galvanized Caps with 1/2" Min. to 1 1/2" Max. height and nominal 1" inside diameter.
5. Include the cost of Bearing Plates in the pay item for Prestressed Beams.
6. For Pad Type and Dimension C, see the 'BEARING PLATE DATA TABLE' in the Structures Plans. For Dimensions J, K1 and K2, see 'TABLE OF BEAM VARIABLES' in the Structures Plans.
7. All details and dimensions shown are along  $\bar{C}$  Beam. Positive Slope shown, Negative Slope similar.
8. Slope is determined along  $\bar{C}$  Beam at  $\bar{C}$  Bearing. See 'BEARING PLATE DATA TABLE' in the Structures Plans for Slope.

**CROSS REFERENCE:**

See Sheet 2 for Detail "A"

10/15/2023 11:44:33 AM

LAST REVISION 07/01/14	DESCRIPTION:		FY 2024-25 <b>STANDARD PLANS</b>	<b>BEARING PLATES (TYPE 2) - PRESTRESSED          FLORIDA-I AND AASHTO TYPE II BEAMS</b>	INDEX <b>450-512</b>	SHEET <b>1 of 2</b>
---------------------------	--------------	--	-------------------------------------	--	-------------------------	------------------------

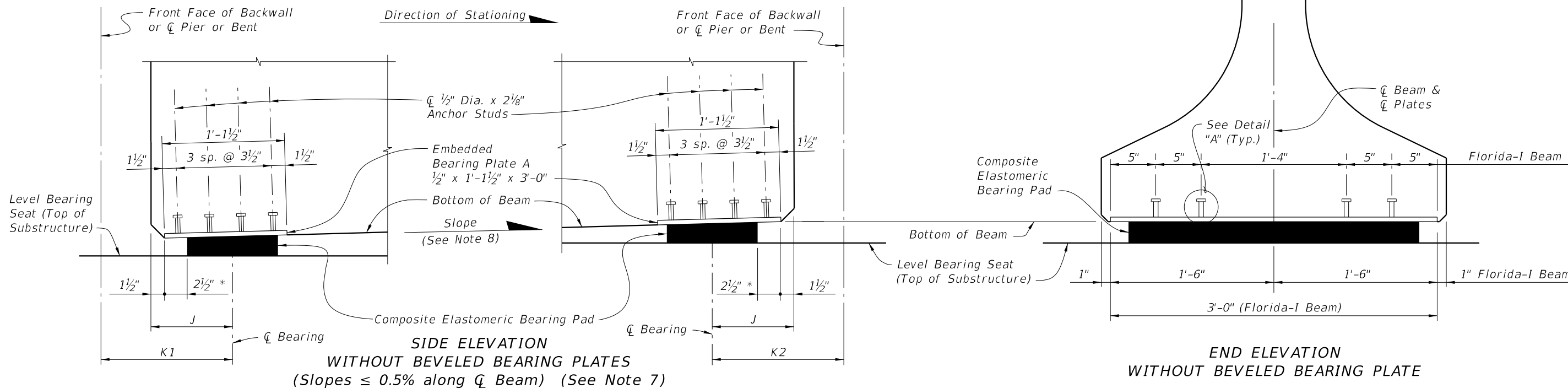

\*  $\frac{1}{2}$ " for Pad Type K

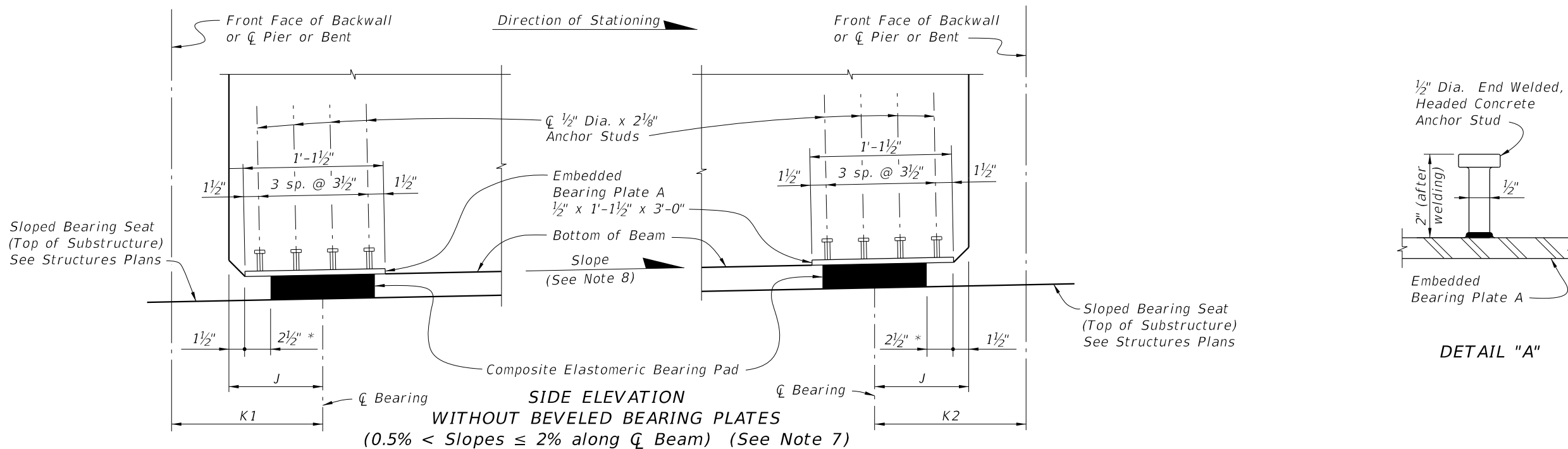

CROSS REFERENCE:  
See Sheet 1 for Notes.

10/15/2023 11:44:40 AM

LAST REVISION 07/01/14	REVISION	DESCRIPTION:	 FY 2024-25 STANDARD PLANS	BEARING PLATES (TYPE 2) - PRESTRESSED FLORIDA-I AND AASHTO TYPE II BEAMS	INDEX 450-512	SHEET 2 of 2
---------------------------	----------	--------------	---	---	------------------	-----------------