

**GENERAL NOTES:**

1. The French Drain Skimmer is a hooded cover, mounted over an outlet in a catchbasin, that prevents oil and floating debris from exiting the basin.
2. Place neoprene gasket material between the skimmer and the catchbasin at all points of contact. Trim the gasket to extend 1/2 inch beyond the joint on all sides.
3. Provide skimmer baffle, cleanout pipe and angles constructed of either galvanized steel, aluminum, polyvinyl chloride, polyethylene, fiberglass or acrylonitrile butadiene styrene. Provide hot-dip galvanized steel components, unless stainless.
4. Use Mounting hardware, hinges and latches made of stainless steel. Loss prevention device can use either stainless steel chain or riveted nylon strap.
5. Provide skimmer bodies (baffles) and cleanout pipe meeting Specification 943 for steel, 945 for aluminum or 948 for plastics.
6. Work this Index in accordance with Specification 425.

TABLE OF CONTENTS:	
Sheet	Description
1	General Notes and Contents
2	Type I Skimmers
3	Type II Skimmers

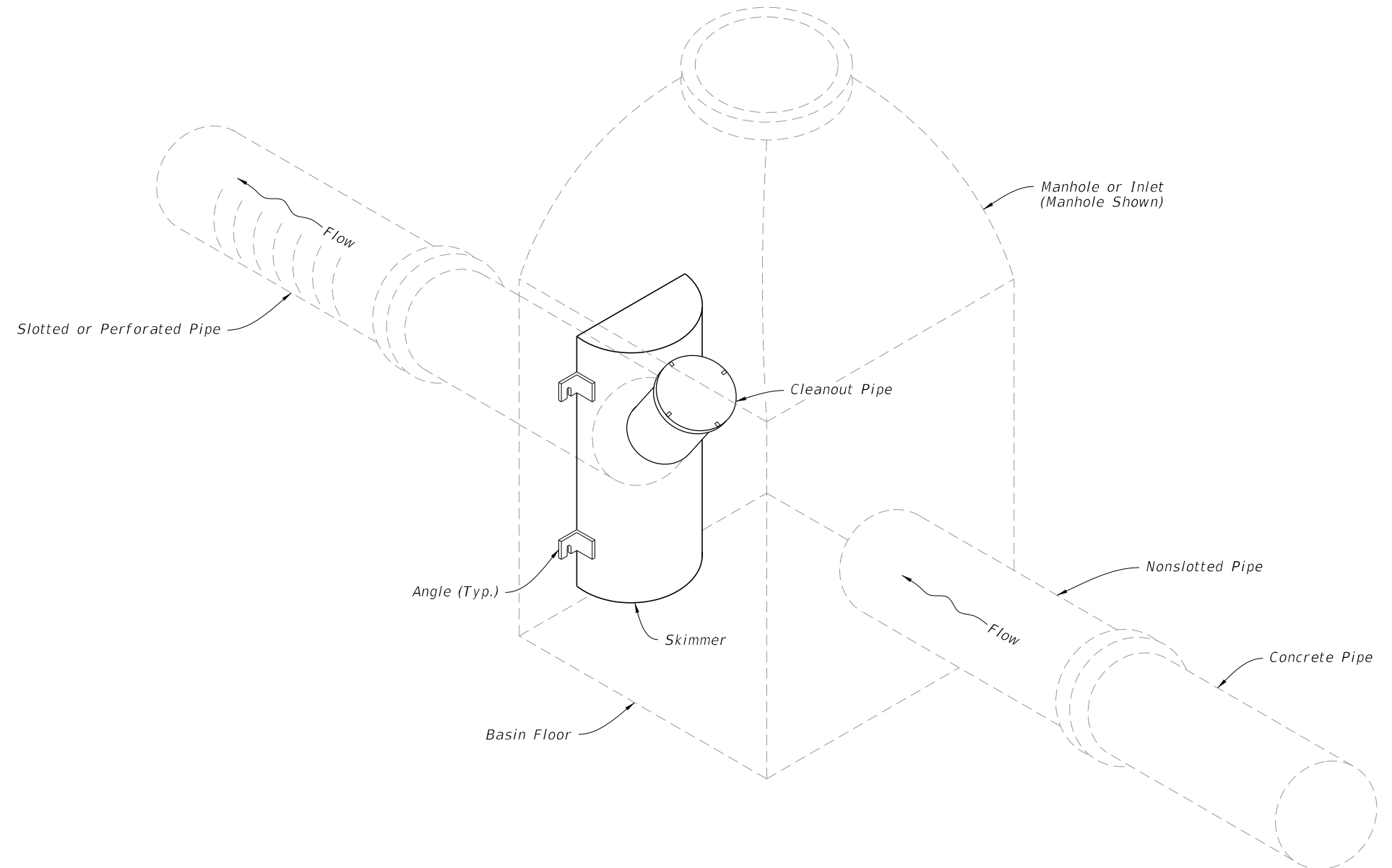

SKIMMER FOR FRENCH DRAIN OUTLETS ASSEMBLY

10/3/2023 12:43:06 PM

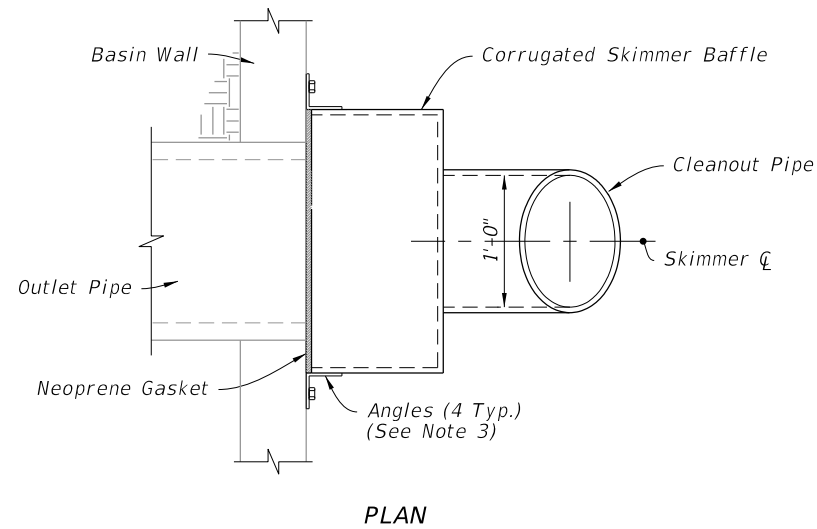

- NOTES:**
1. Conform the backs of skimmers to the shape of the basin walls on which they are mounted.
  2. "R" is the radii required for curved back skimmers. Applies to both skimmer types. See Plans.
  3. Weld Angles at all points of contact with skimmer.

DIMENSION TABLE			
OUTLET PIPE	A	B	C
18"	12"	42"	24"
24"	15"	48"	30"
30"	18"	54"	36"
36"	21"	60"	42"

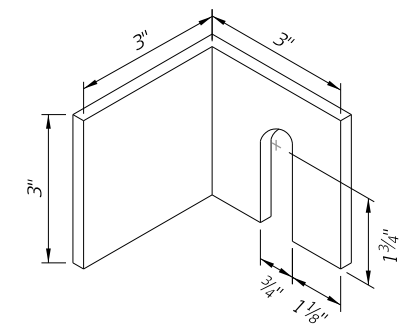
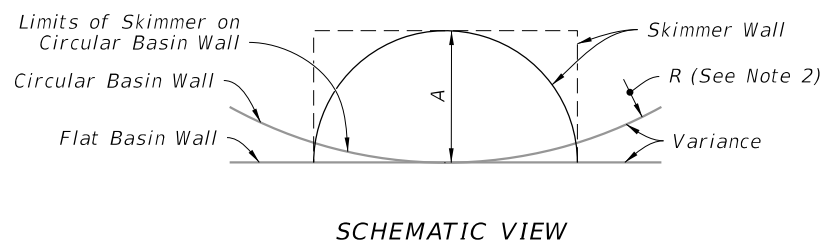
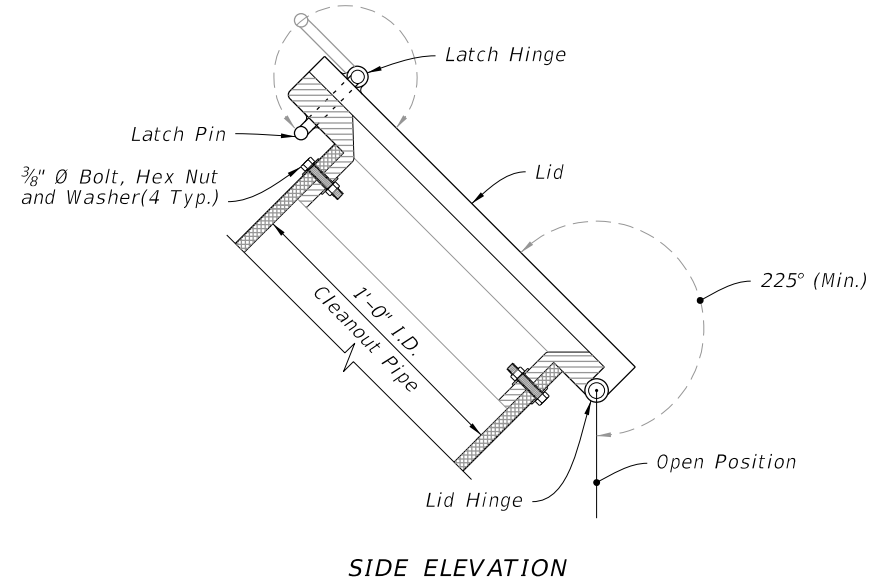
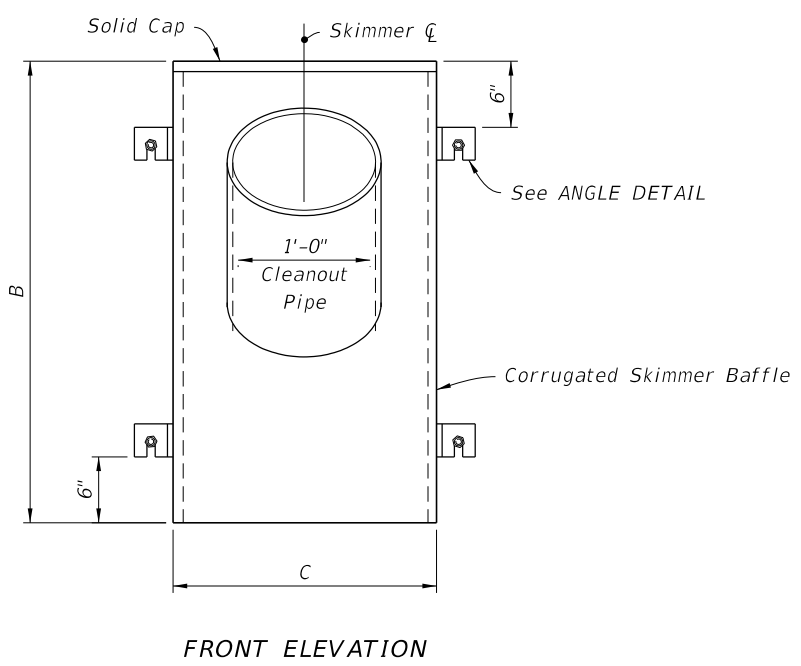
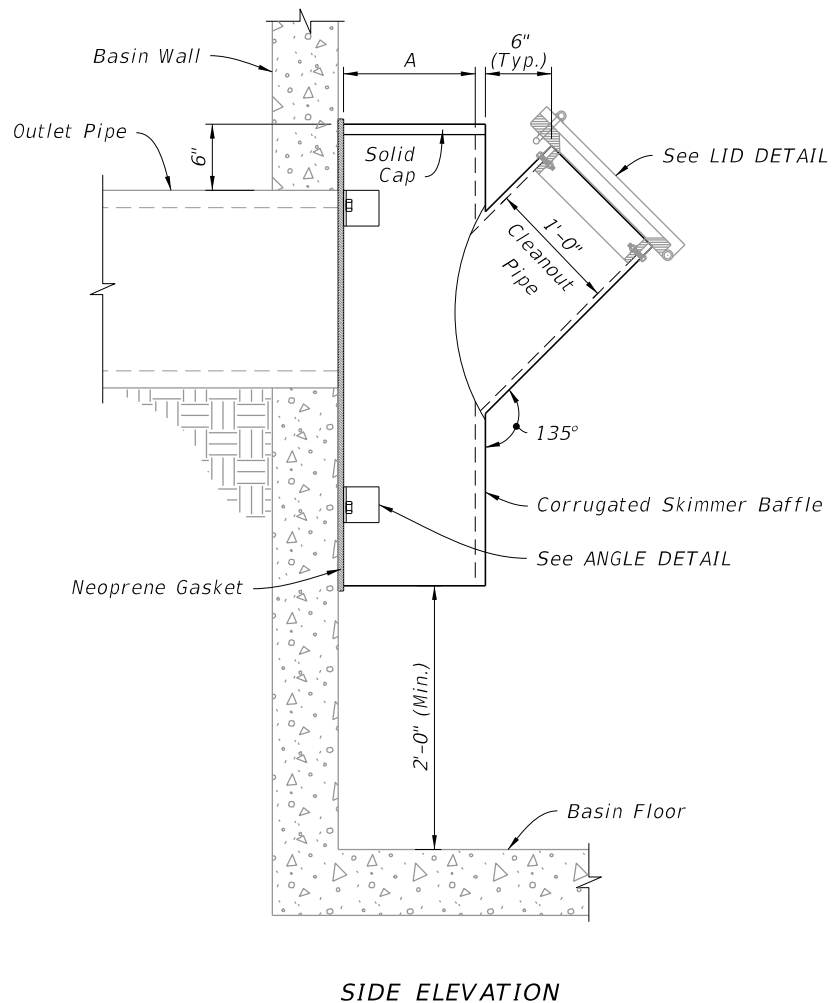
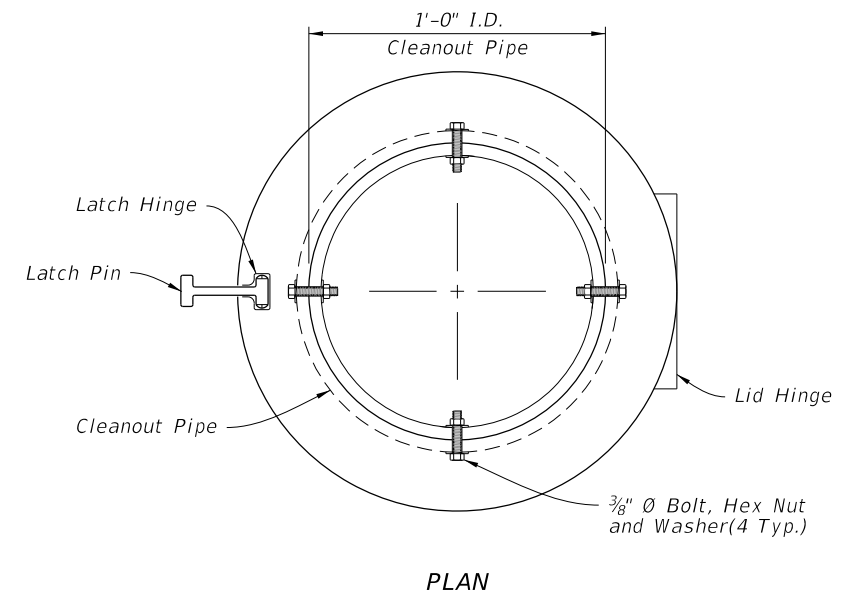

TYPE I DETAILS

ANGLE DETAIL

TYPE I SKIMMERS

10/3/2023 12:43:13 PM

LAST REVISION 11/01/19	REVISION	DESCRIPTION:
---------------------------	----------	--------------

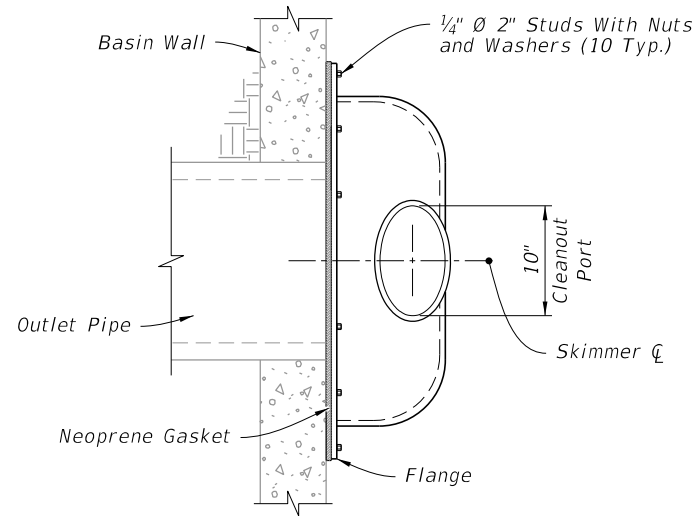

PLAN

**NOTE:**

Install a gasket for the cleanout with either a threaded screw-in lid or a lid secured by four stainless steel quick-release latches.

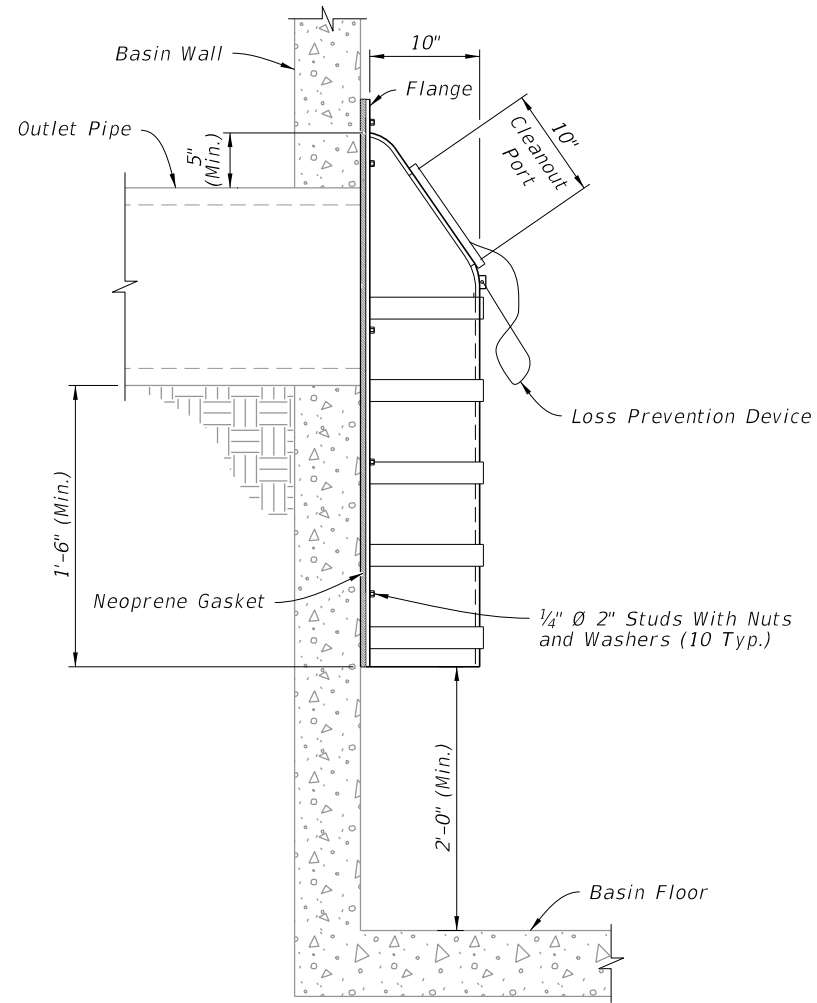

SIDE ELEVATION

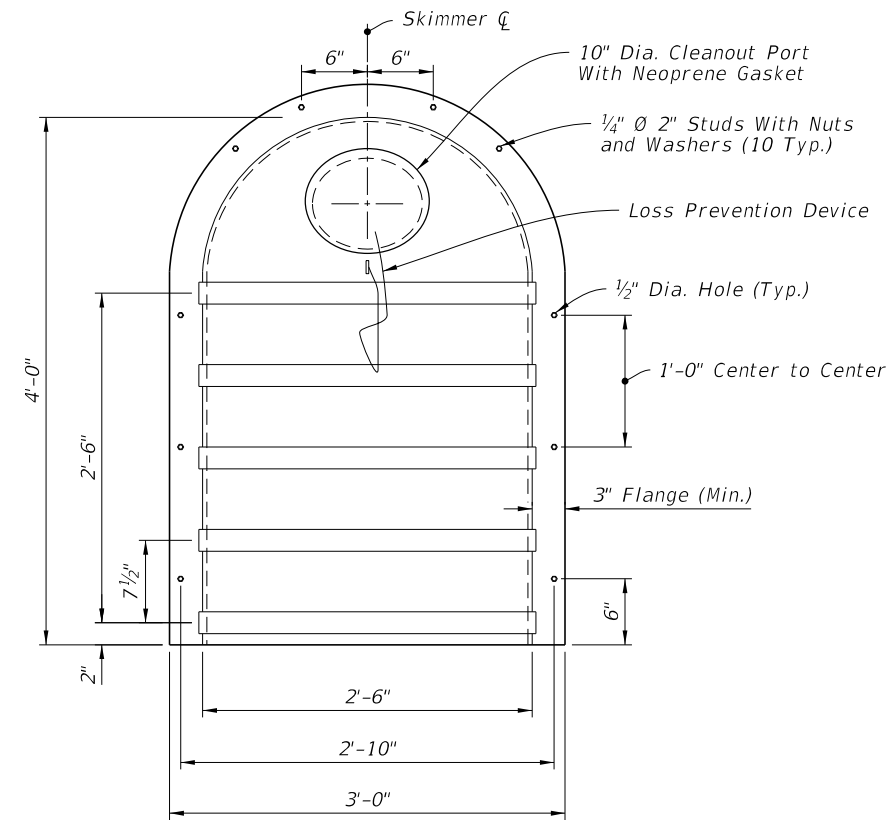

FRONT ELEVATION

TYPE II DETAILS

TYPE II SKIMMERS

10/3/2023 12:43:19 PM

LAST REVISION 11/01/19	DESCRIPTION:
---------------------------	--------------



FY 2024-25  
STANDARD PLANS

SKIMMERS FOR FRENCH DRAIN OUTLETS

INDEX  
443-002

SHEET  
3 of 3