

GENERAL NOTES:

1. The side panels are dimensionally symmetric, and may be used on either side of the structure.
2. Two (2) skimmers may be installed on a single structure provided they are constructed on opposite ends.
3. The width of the front panel (dimension W) is equal to the same as the outside dimension across the front of the structure.
4. Hot dip galvanize the front panel, side panels, and flat bars after fabrication.
5. The location of the reinforcing steel in these structures must conform to the Index 425-052 to avoid conflict with the expansion anchors used to attach the skimmer.
6. Use grates on the inlets unless otherwise specified in the Plans.
7. A skimmer consists of two (2) side panels, one front panel, two (2) flat bars, and accessory hardware.

TABLE OF CONTENTS:	
Sheet	Description
1	General Notes and Contents
2	Panel and Flat Bar Details
3	Installation Details

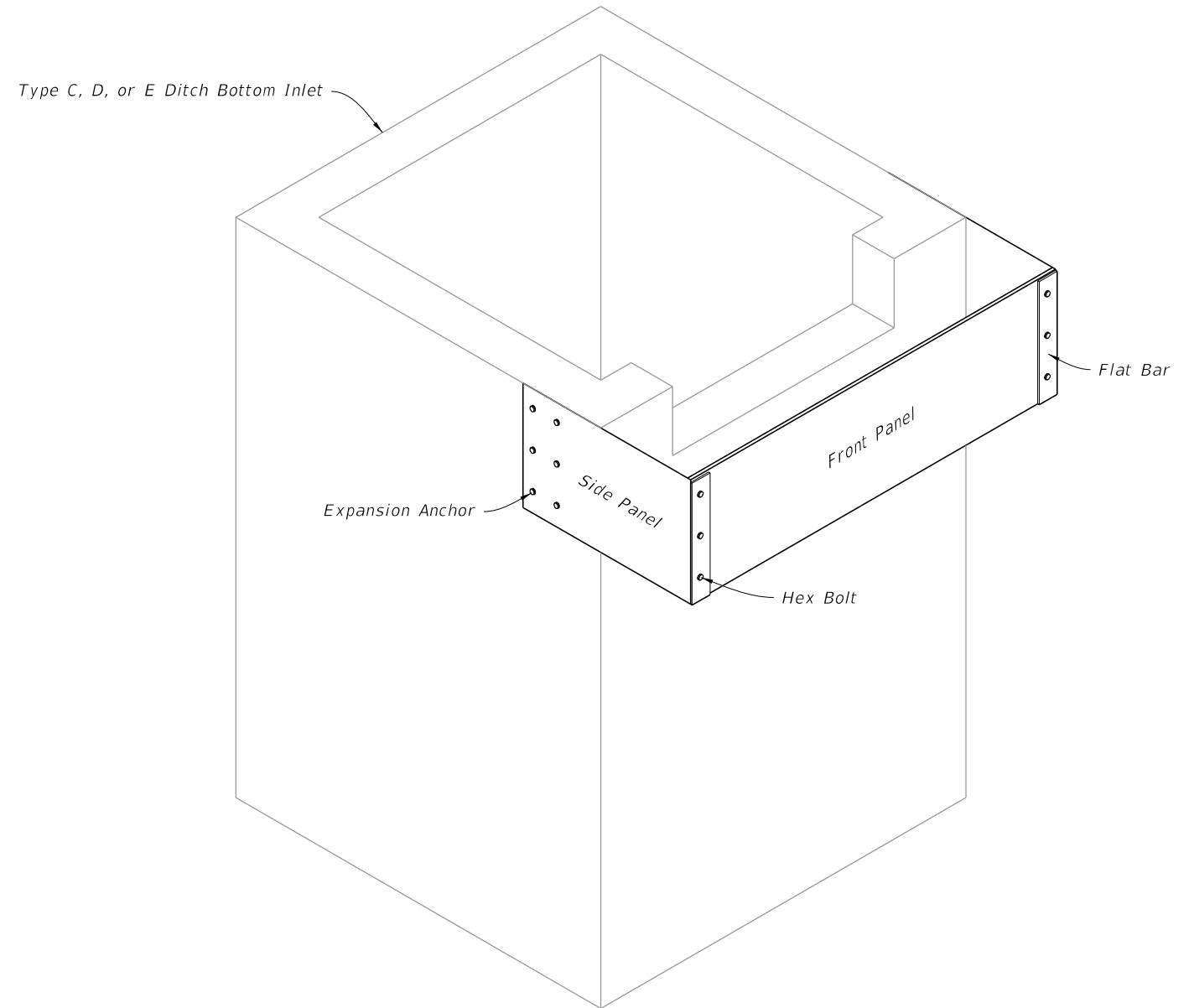

==== SKIMMER =====

9/28/2023 4:45:31 PM

DIMENSIONS				
Skimmer Height as Specified in the Plans				Bolt Spacing
H (in.)	D (in.)	E (in.)	L (in.)	S (in.)
12	3 ³ / ₁₆	3	28	3
14	3 ³ / ₁₆	3	28	4
16	3 ³ / ₁₆	3	28	5
18	3 ³ / ₁₆	3	28	6
20	4 ³ / ₁₆	4	31	6
22	4 ³ / ₁₆	4	31	7
24	4 ³ / ₁₆	4	31	8
26	4 ³ / ₁₆	4	31	9
28	4 ³ / ₁₆	4	31	10
30	5 ³ / ₁₆	5	31	10
32	5 ³ / ₁₆	5	31	11
34	5 ³ / ₁₆	5	31	12
36	6 ³ / ₁₆	6	31	12
38	6 ³ / ₁₆	6	31	13
40	6 ³ / ₁₆	6	31	14

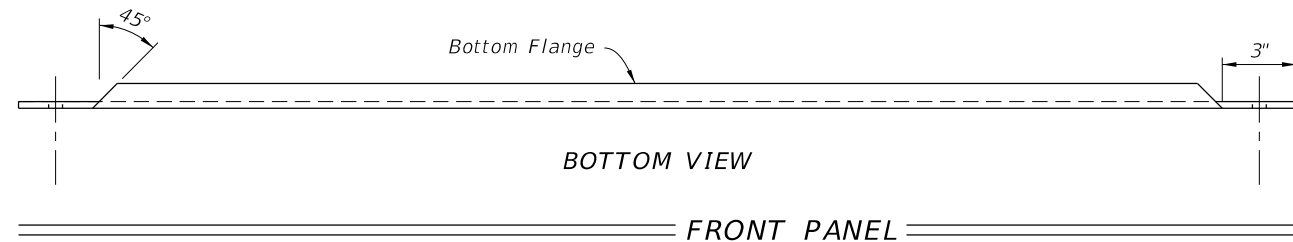
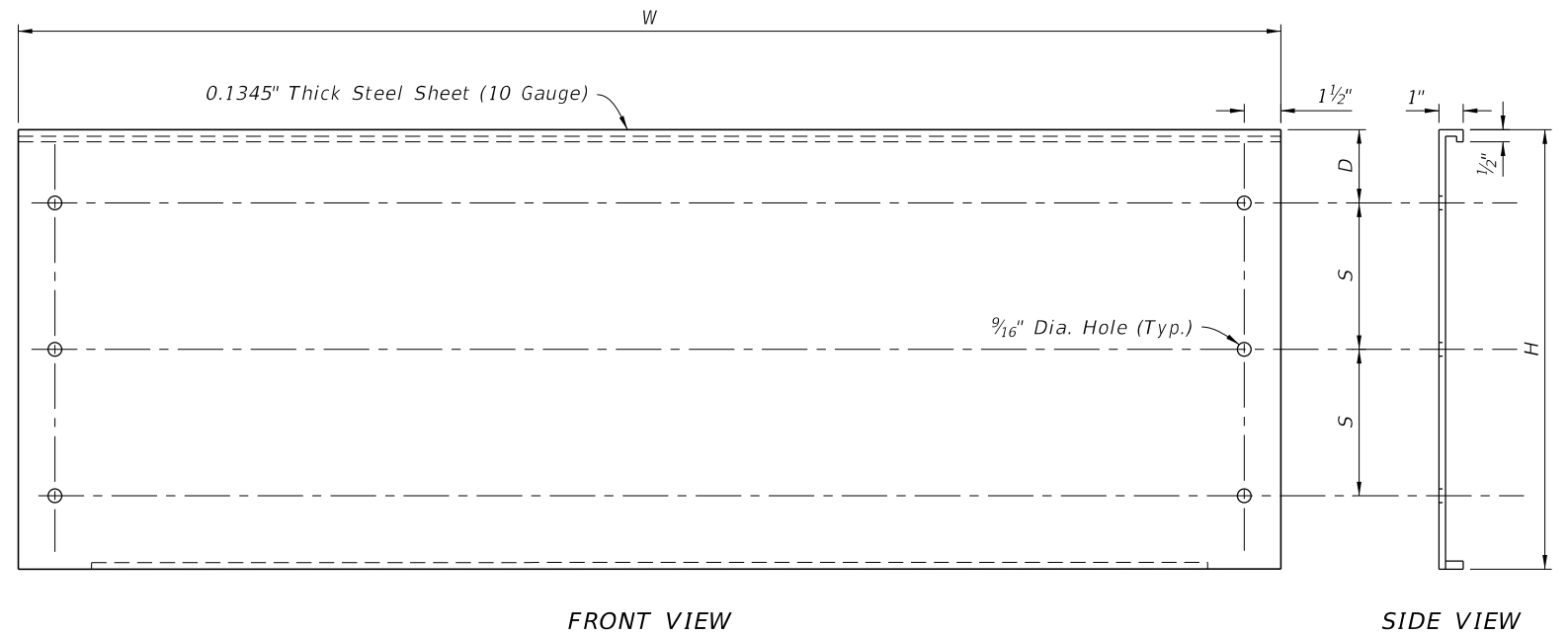
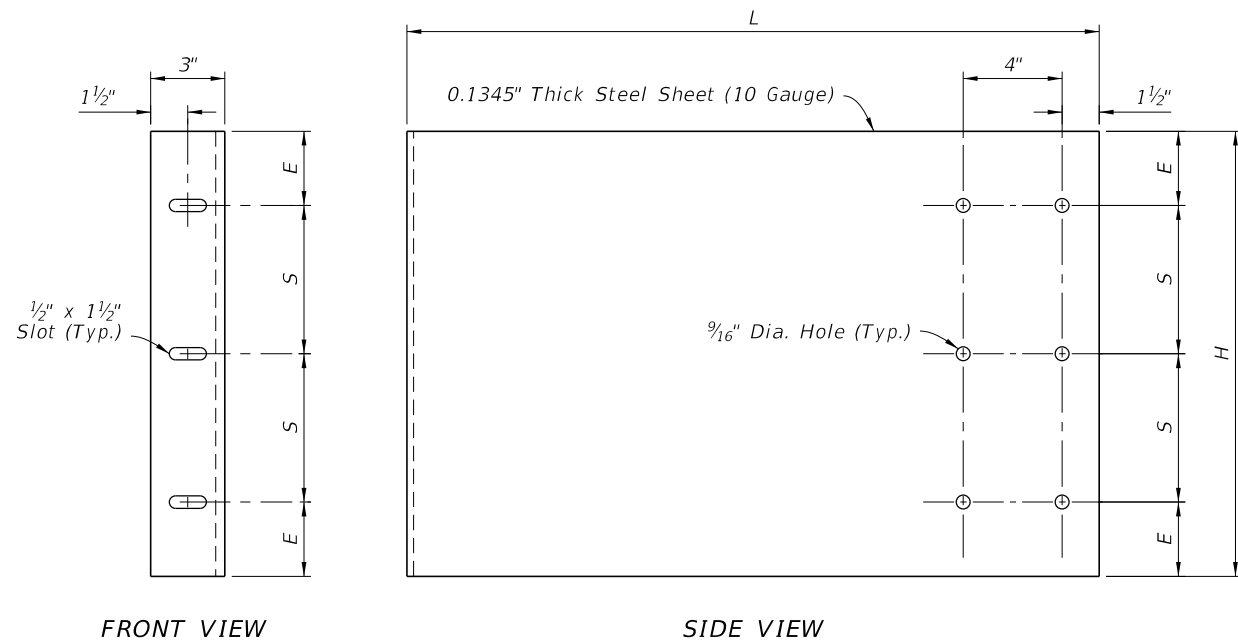
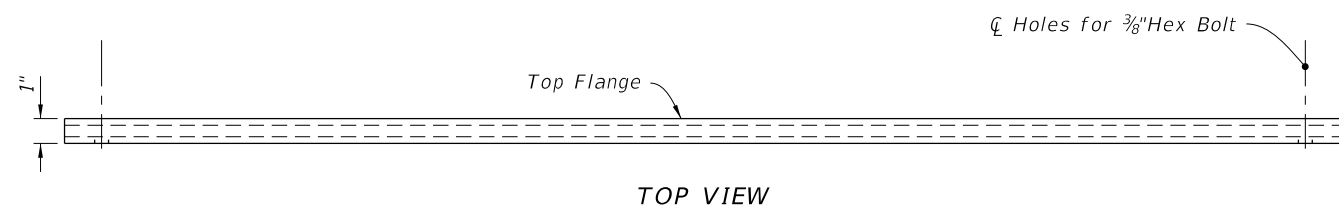
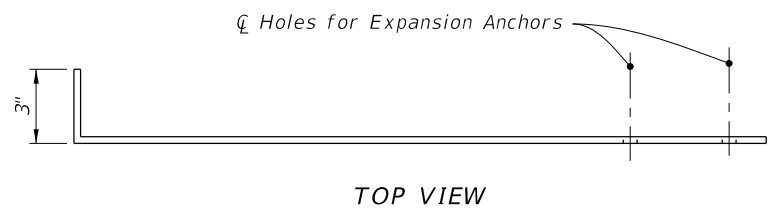
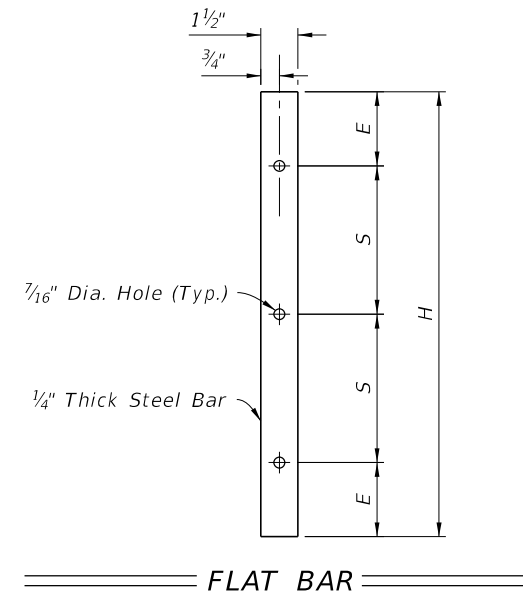

SIDE PANEL

FRONT PANEL

PANEL AND FLAT BAR DETAILS

9/28/2023 4:45:35 PM

LAST REVISION 11/01/20	DESCRIPTION:		FY 2024-25 STANDARD PLANS	SKIMMER FOR OUTLET CONTROL STRUCTURES	INDEX	SHEET
					425-070	2 of 3

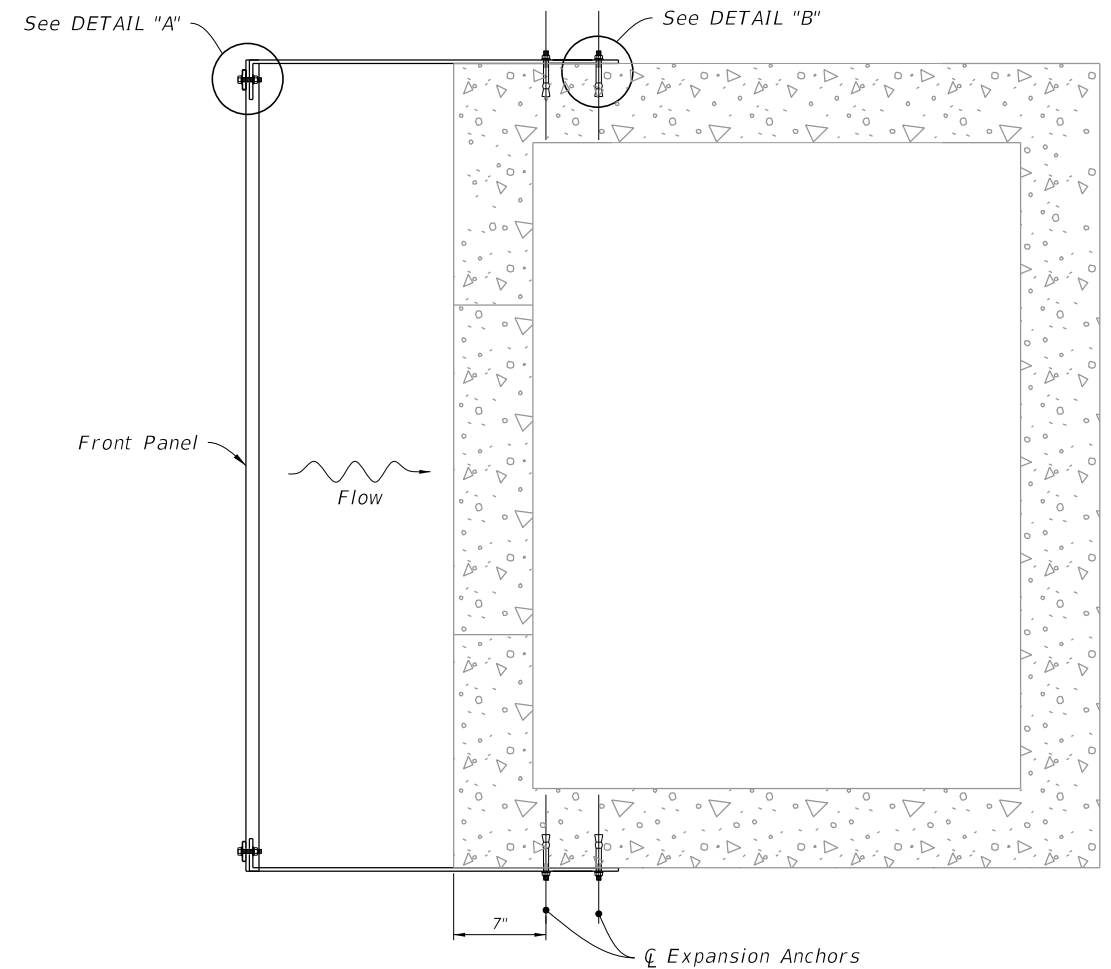
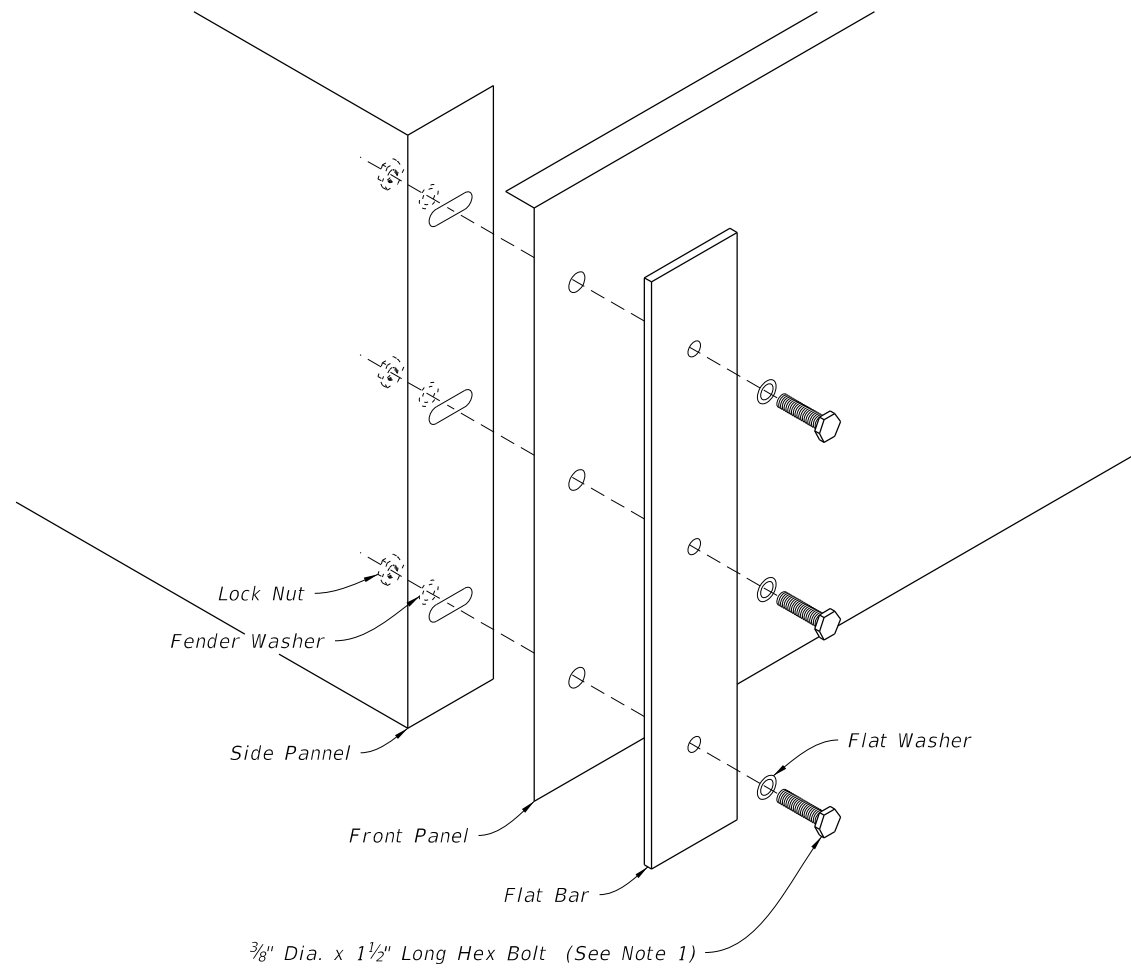

PLAN

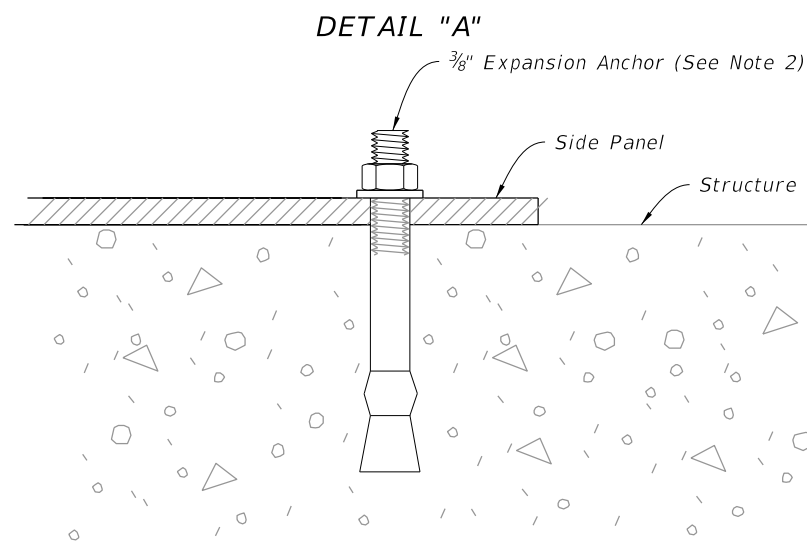

DETAIL "A"

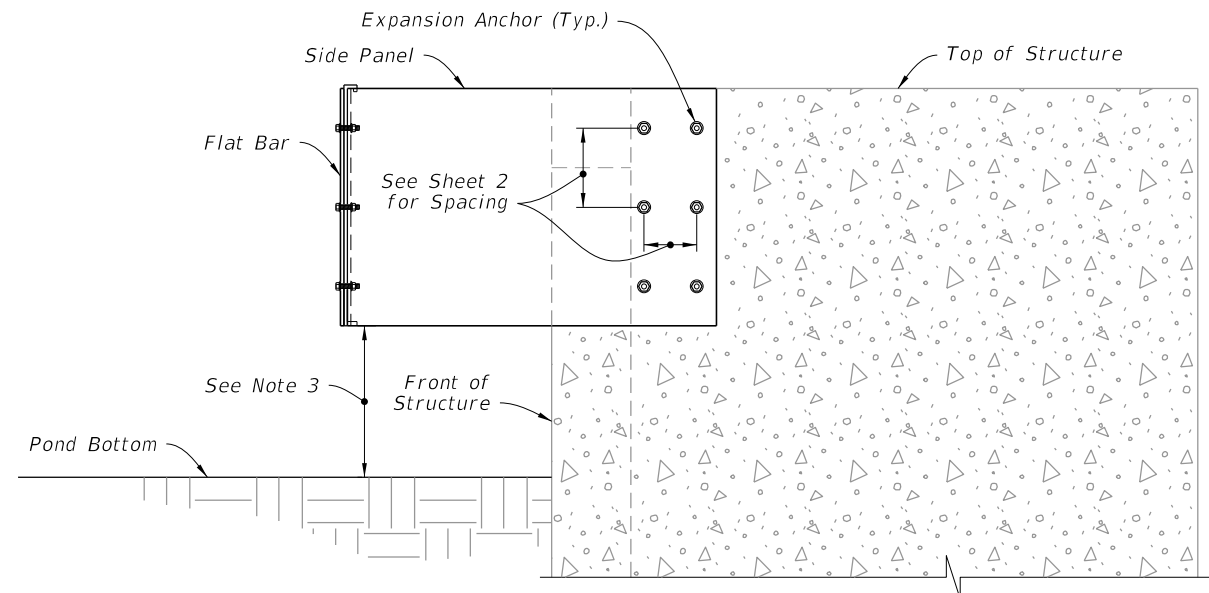

SIDE ELEVATION

NOTES:

1. Hex Bolt, Flat Washer, Fender Washer, And Lock Nut, all Stainless Steel. (6 Required Per Skimmer)
2. Install a stainless steel stud type expansion anchor with nut and washer. Embedment depth = 2 1/2". Anchors to be installed according to the manufacturer's recommendations (12 required per skimmer).
3. Install the skimmer so that the distance between the pond bottom at the structure and the skimmer is not less than 1 foot.

4:45:39 PM 9/28/2023

INSTALLATION DETAILS

LAST REVISION 11/01/20	REVISION	DESCRIPTION:		FY 2024-25 STANDARD PLANS	SKIMMER FOR OUTLET CONTROL STRUCTURES	INDEX 425-070	SHEET 3 of 3
---------------------------	----------	--------------	--	------------------------------	---------------------------------------	------------------	-----------------