

GENERAL NOTES:

1. Work this Index with Index 425-001 and Index 550-002.
2. Chamfer all exposed edges and corners $\frac{3}{4}$ " or tooled to $\frac{1}{4}$ " radius.
3. Use Class II concrete for inlet and anti-vortex wall.
4. Use Grade 60 reinforcing bars with 2" minimum cover unless otherwise noted. See Index 425-001 for equivalent area of welded wire reinforcing (WWR). Cut or bend bars for 1 $\frac{1}{2}$ " clearance around pipe opening. Bend top and corner bars to clear anchor holes.
5. Channel section C 3x6 at 14" max. bar spacing may be used as an alternate for the C 4x5.4 channel at 15" bar spacing.
6. Channels and bars for grate are ASTM A242/A242M, A572/A572M or A588/A588M, Grade 50 steel, and galvanized in accordance with Specification 975.
7. Use Fence Type B for fence enclosure (Index 550-002). Install all posts in concrete. A minimum of 10 posts required. Use 3" nominal diameter posts for corner and approach side posts.
8. Anchor Bolts are ASTM F1554 Grade 36 fully threaded headless bolts, installed in accordance with Specifications 416 and 937. Nuts are ASTM A563 or A194 and washers are ASTM F436 or Type A plain washers. Galvanize all nuts, bolts and washers.
9. Quantities are for informational and estimating purposes only.

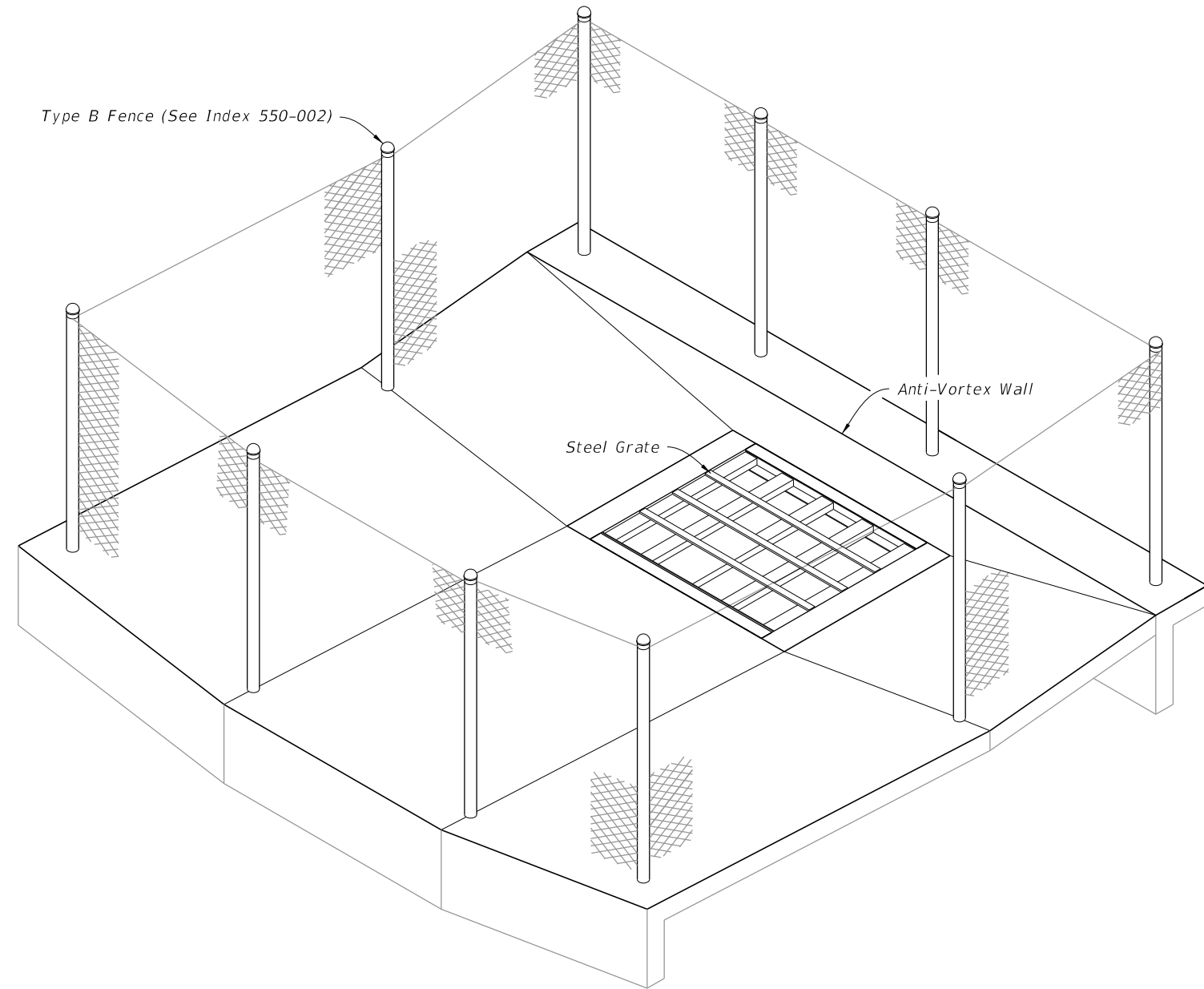

===== INLET FENCE ENCLOSURE =====

TABLE OF CONTENTS:

Sheet	Description
1	General Notes and Contents
2	Inlet Lengths (L) Less Than or Equal to 9'
3	Inlet Lengths (L) Greater Than or Equal to 9'
4	Steel Grate Details

9/28/2023 4:32:50 PM

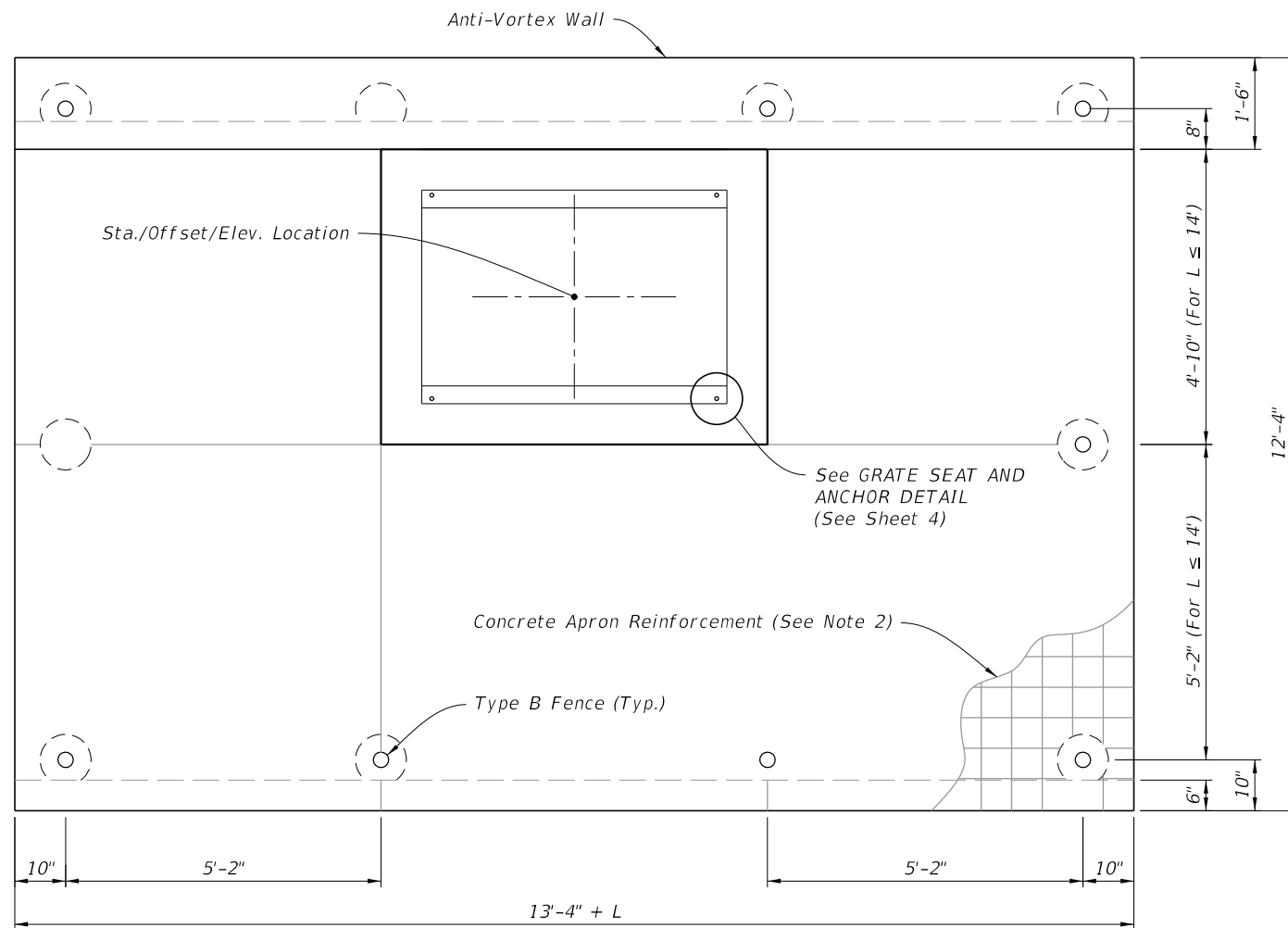

PLAN

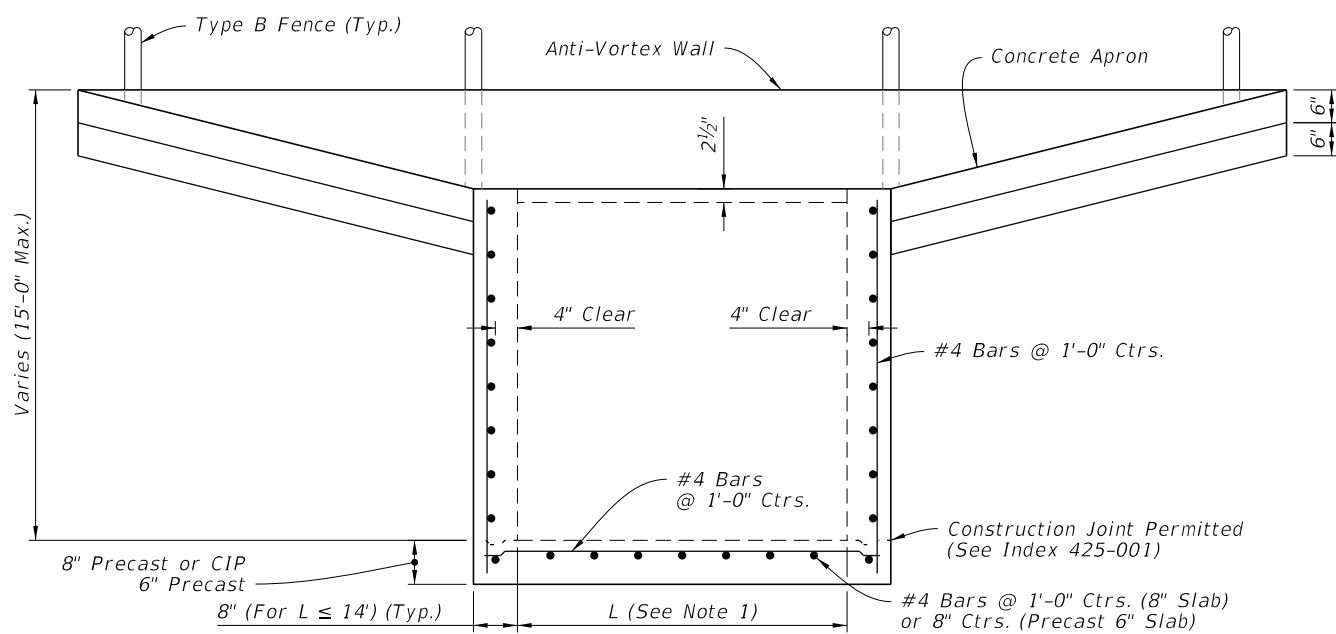

(See Note 4)
FRONT ELEVATION

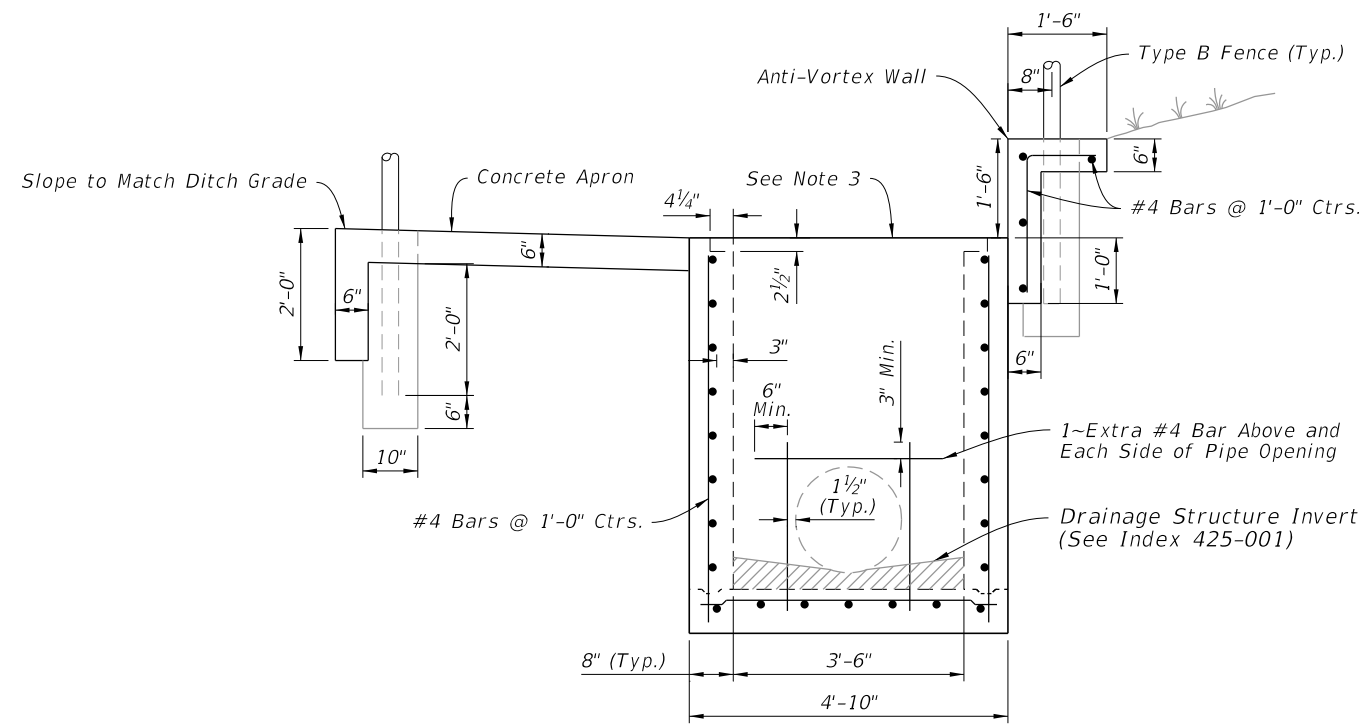

SIDE ELEVATION

TABLE 1
SINGLE LAYER REINFORCING
Horizontal Wall Reinforcing Schedules

WALL DEPTH	SCH.	AREA (in ² /ft)	MAX. SPACING	
			BARS	WWR
SIZE: L = 5'-0"				
0'-5'	A12	0.20	12"	8"
5'-8'	A6	0.20	6"	5"
8'-15'	B5.5	0.24	5 1/2"	5"
SIZE: L = 6'-0"				
0'-4'	A12	0.20	12"	8"
4'-6'	B5.5	0.24	5 1/2"	5"
6'-9'	C6.5	0.37	6 1/2"	6"
9'-15'	C3.5	0.37	3 1/2"	3"
SIZE: L = 7'-0"				
0'-4'	B5.5	0.24	5 1/2"	5"
4'-7'	C6.5	0.37	6 1/2"	6"
7'-15'	D4.5	0.53	4 1/2"	4"
SIZE: L = 8'-0"				
0'-3'	B5.5	0.24	5 1/2"	5"
3'-5'	C6.5	0.37	6 1/2"	6"
5'-9'	D4.5	0.53	4 1/2"	4"
9'-15'	E5	0.73	5"	4"
SIZE: L = 9'-0"				
0'-4'	C6.5	0.37	6 1/2"	6"
4'-7'	D4.5	0.53	4 1/2"	4"
7'-15'	E3	0.73	3"	3"

NOTES:

1. See Plans for Inlet length (L).
2. Use 6"x6" 10/10 welded wire reinforcing.
3. Grate not shown.
4. Pipe opening not shown.

INLET LENGTHS (L) LESS THAN OR EQUAL TO 9'

9/28/2023 4:32:54 PM

LAST REVISION 11/01/20	REVISION	DESCRIPTION:		FY 2024-25 STANDARD PLANS	DITCH BOTTOM INLET TYPE K	INDEX 425-055	SHEET 2 of 4
---------------------------	----------	--------------	--	------------------------------	---------------------------	------------------	-----------------

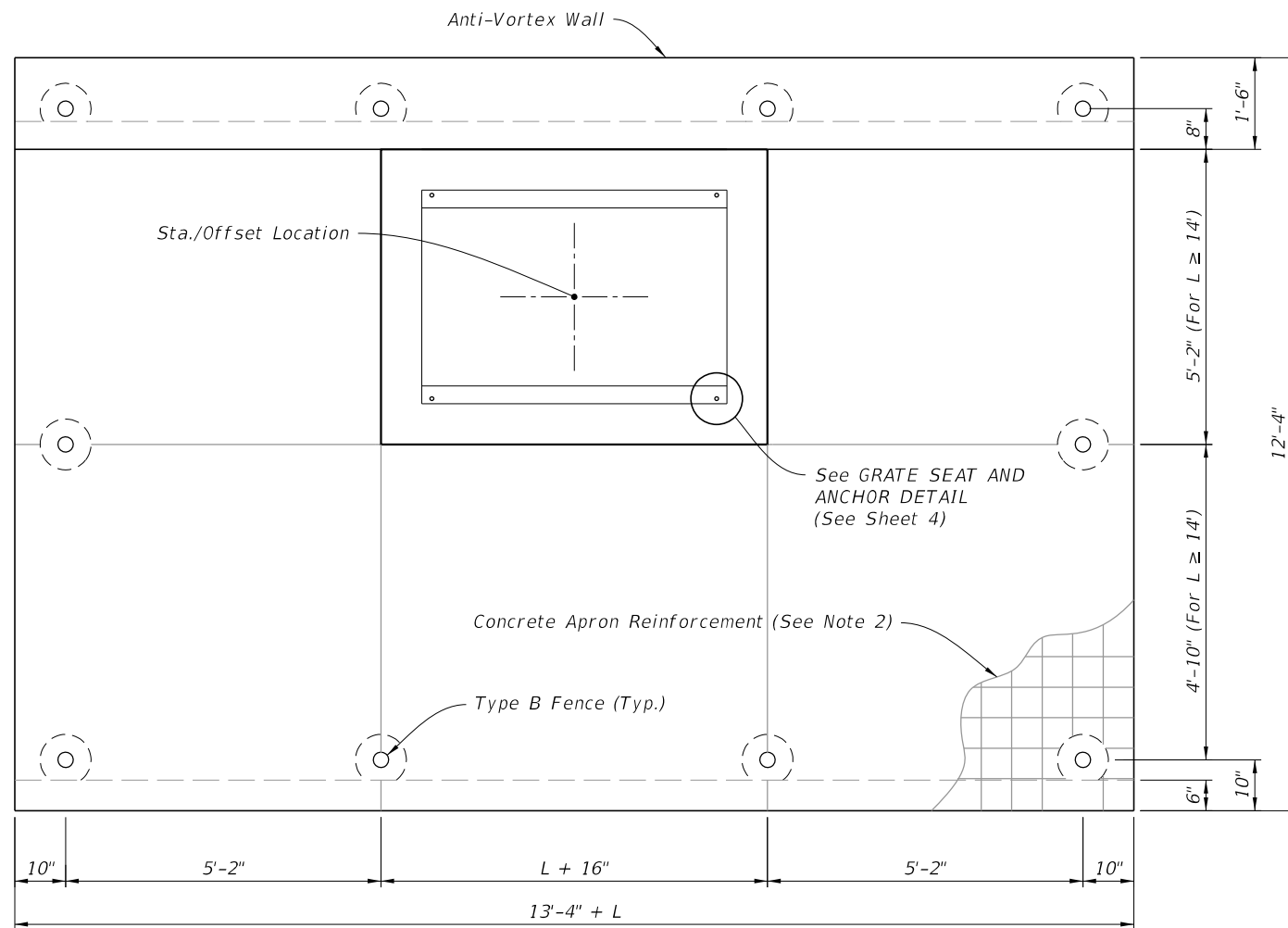

PLAN

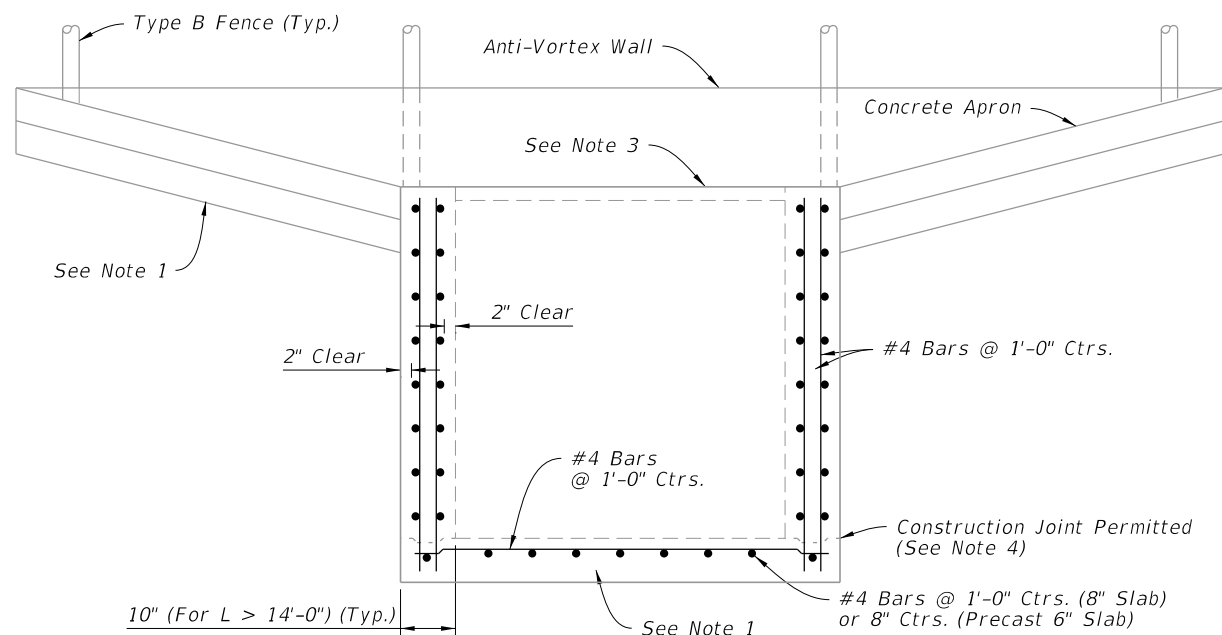

(See Note 5)
FRONT ELEVATION

TABLE 2
DOUBLE LAYER REINFORCING
Horizontal Wall Reinforcing Schedules

WALL DEPTH	SCH.	AREA (in ² /ft)	MAX. SPACING BARS	WWR
SIZE: L = 9'-0"				
0'-4"	A12	0.20	12"	8"
4'-6"	A6	0.20	6"	5"
6'-8"	B5.5	0.24	5½"	5"
8'-15"	C6.5	0.37	6½"	6"
SIZE: L = 10'-0"				
0'-3"	A12	0.20	12"	8"
3'-5"	A6	0.20	6"	5"
5'-8"	C6.5	0.37	6½"	6"
8'-15"	C3.5	0.37	3½"	3"
SIZE: L = 12'-0"				
0'-4"	B5.5	0.24	5½"	5"
4'-6"	C6.5	0.37	6½"	6"
6'-15"	D4.5	0.53	4½"	4"
SIZE: L = 14'-0"				
0'-4"	C6.5	0.37	6½"	6"
4'-7"	D4.5	0.53	4½"	4"
7'-15"	E5	0.73	5"	4"
SIZE: L = 16'-0" x 10" WALL THICK				
0'-4"	C6.5	0.37	6½"	6"
4'-8"	D4.5	0.53	4½"	4"
8'-15"	E5	0.73	5"	4"
SIZE: L = 18'-0" x 10" WALL THICK				
0'-3"	C6.5	0.37	6½"	6"
3'-5"	D4.5	0.53	4½"	4"
5'-8"	E5	0.73	5"	4"
8'-15"	F5	1.06	5"	4"

NOTE:

1. See Sheet 2 for dimension details.
2. Use 6"x6" 10/10 welded wire reinforcing.
3. Grate not shown.
4. See Index 425-001 for construction joint details.
5. Pipe Opening not shown.

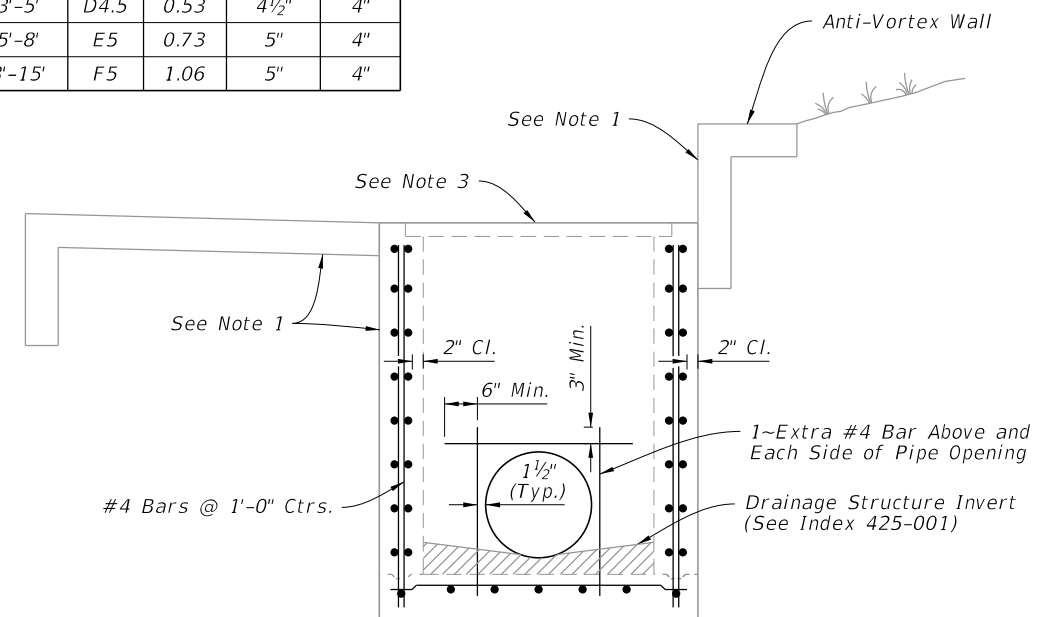

SIDE ELEVATION

INLET LENGTHS (L) GREATER THAN OR EQUAL TO 9'

9/28/2023 4:32:56 PM

LAST REVISION 11/01/20	REVISION	DESCRIPTION:		FY 2024-25 STANDARD PLANS	DITCH BOTTOM INLET TYPE K	INDEX 425-055	SHEET 3 of 4
---------------------------	----------	--------------	--	------------------------------	---------------------------	------------------	-----------------

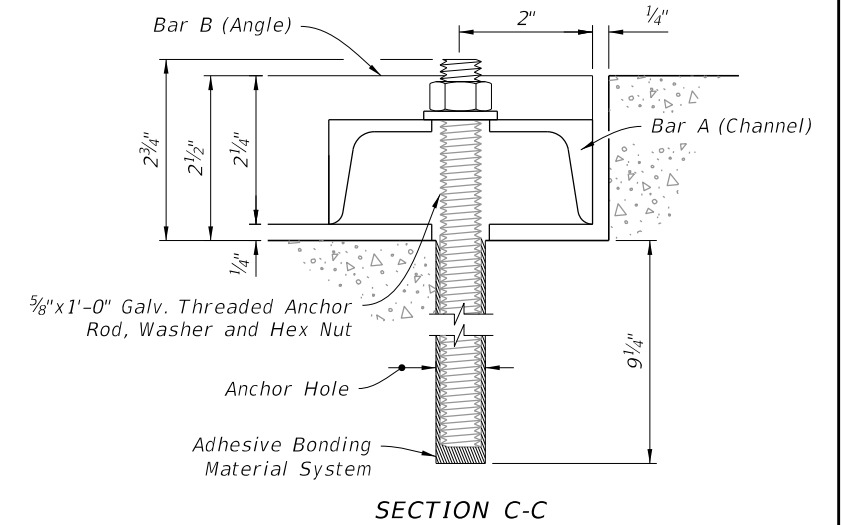
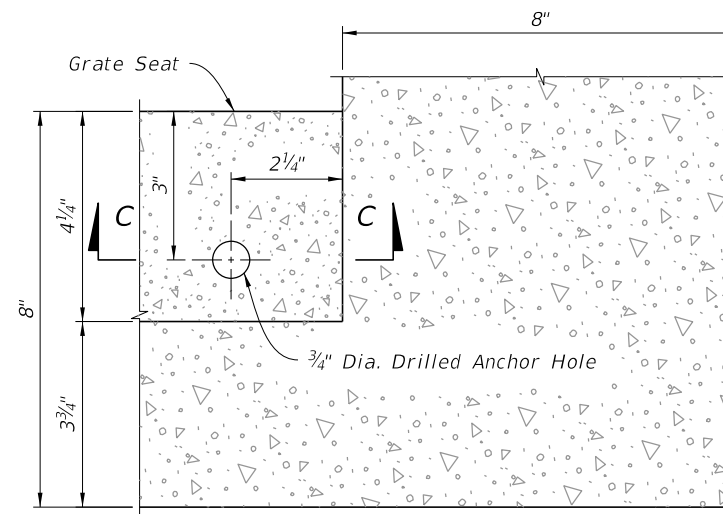
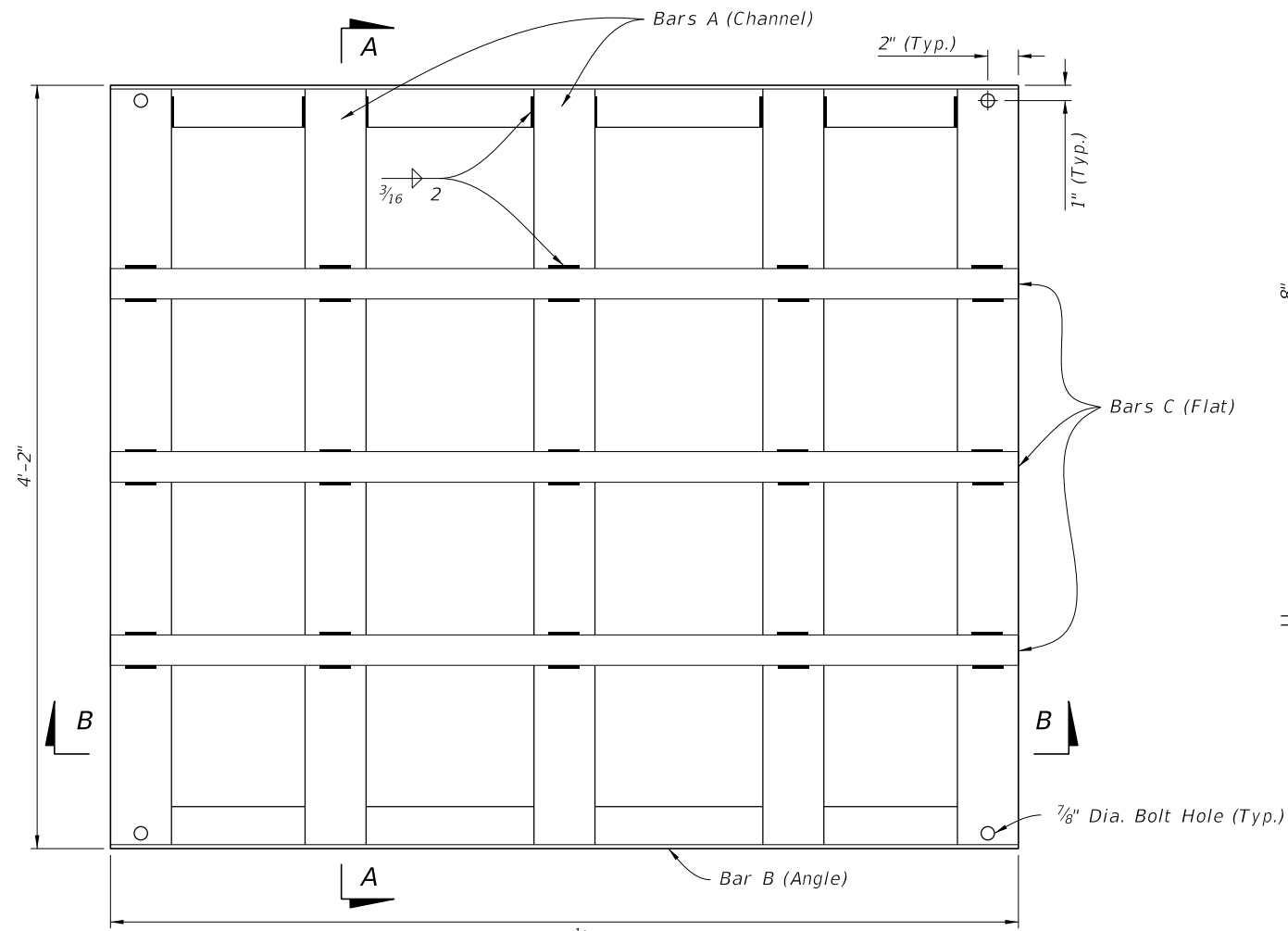

GRATE SEAT AND ANCHOR DETAILS

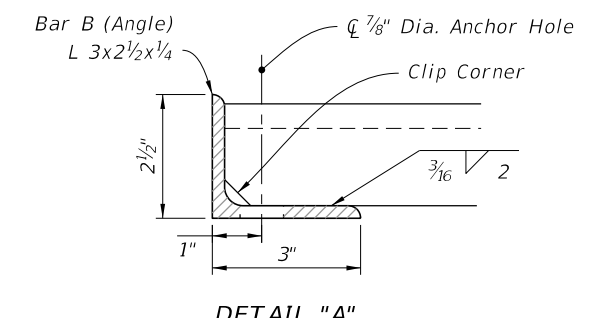
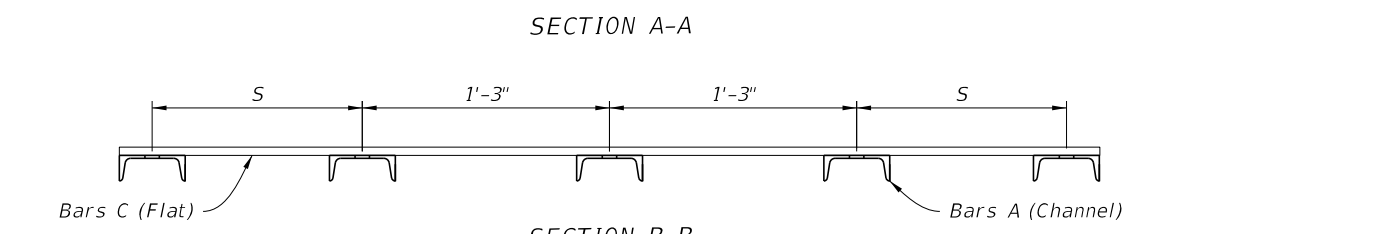
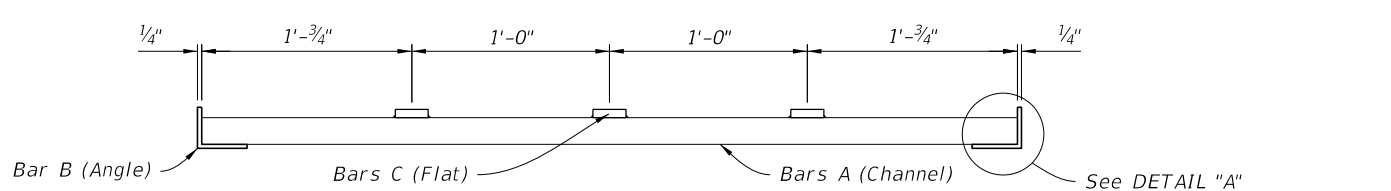

NOTES:
 1. See Sheet 2 for dimension "L" location.
 2. See Section B-B for dimension "S" location.

PIPE SIZE	L See Note 1	S	BILL OF STEEL			STEEL WEIGHT		
			BAR	No. REQD.	LENGTH	CHANNEL 4" x 5.4 lb	ANGLE 3" x 2 1/2" x 1/4" (4.5 lb/ft)	FLAT 2" x 1/2" (3.4 lb/ft)
30" & 36"	5'-0"	12 3/4"	A	5	4'-1 1/2"	111	45	51
			B	2	4'-11 1/2"			
			C	3	4'-11 1/2"			
42" & 48"	6'-0"	11 1/4"	A	6	4'-1 1/2"	134	54	61
			B	2	5'-11 1/2"			
			C	3	5'-11 1/2"			
54" & 60"	7'-0"	9 3/4"	A	7	4'-1 1/2"	156	63	71
			B	2	6'-11 1/2"			
			C	3	6'-11 1/2"			
66" & 72"	8'-0"	8 1/4"	A	8	4'-1 1/2"	178	72	81
			B	2	7'-11 1/2"			
			C	3	7'-11 1/2"			
84"	9'-0"	14 1/4"	A	8	4'-1 1/2"	178	81	91
			B	2	8'-11 1/2"			
			C	3	8'-11 1/2"			
SPECIAL	10'-0"	12 3/4"	A	9	4'-1 1/2"	201	90	102
			B	2	9'-11 1/2"			
			C	3	9'-11 1/2"			
SPECIAL	12'-0"	9 3/4"	A	11	4'-1 1/2"	245	108	122
			B	2	11'-11 1/2"			
			C	3	11'-11 1/2"			
SPECIAL	14'-0"	14 1/4"	A	12	4'-1 1/2"	267	126	142
			B	2	13'-11 1/2"			
			C	3	13'-11 1/2"			
SPECIAL	16'-0"	11 1/4"	A	14	4'-1 1/2"	312	144	163
			B	2	15'-11 1/2"			
			C	3	15'-11 1/2"			
SPECIAL	18'-0"	8 1/4"	A	16	4'-1 1/2"	356	162	183
			B	2	17'-11 1/2"			
			C	3	17'-11 1/2"			

STEEL GRATE DETAILS

9/28/2023 4:33:03 PM