

GENERAL NOTES:

1. Work this Index with Index 425-001 and Index 425-010.
2. When called for in the Plans, use this inlet in conjunction with median or shoulder barrier per Index 521-001 or a barrier with junction slab and wall coping per Index 521-610.
3. Reinforce the upper 2'-3" of the inlet in accordance with sections CC, DD, and EE regardless of construction method.
4. Chamfer exposed edges and corners to $\frac{3}{4}$ " or tool to $\frac{1}{4}$ " radius.
5. Do not field install roller bars when Alt. G grates are specified in the Plans in accordance with Specification 425. Adjust tolerance during fabrication or casting, or match grate to structure prior to galvanizing.
6. Use Grade 60, #4 bars for reinforcing steel. See Index 425-001 for equivalent area of welded wire fabric.
7. Dimensions are for both precast and cast-in-place inlets unless otherwise noted.
8. Anchor bolts: Use either ASTM A307 hex head bolts cast-in-place, or ASTM A36 or F1554 (Grade 36) galvanized fully threaded rod, adhesive bonded anchors installed in accordance with Specification 416. Rods must be a minimum of 6" long with 4" minimum embedment with one ASTM 194 or A563 heavy hex head nut and one ASTM F436 flat washer each. Hot-dip galvanize anchor bolts, nuts, and washers.
9. Reduce Cross Slope: Use a flatter cross slope as required to match adjacent grading per the Plans. Reduce vertical dimensions and bar spacing as needed to maintain concrete cover as shown.

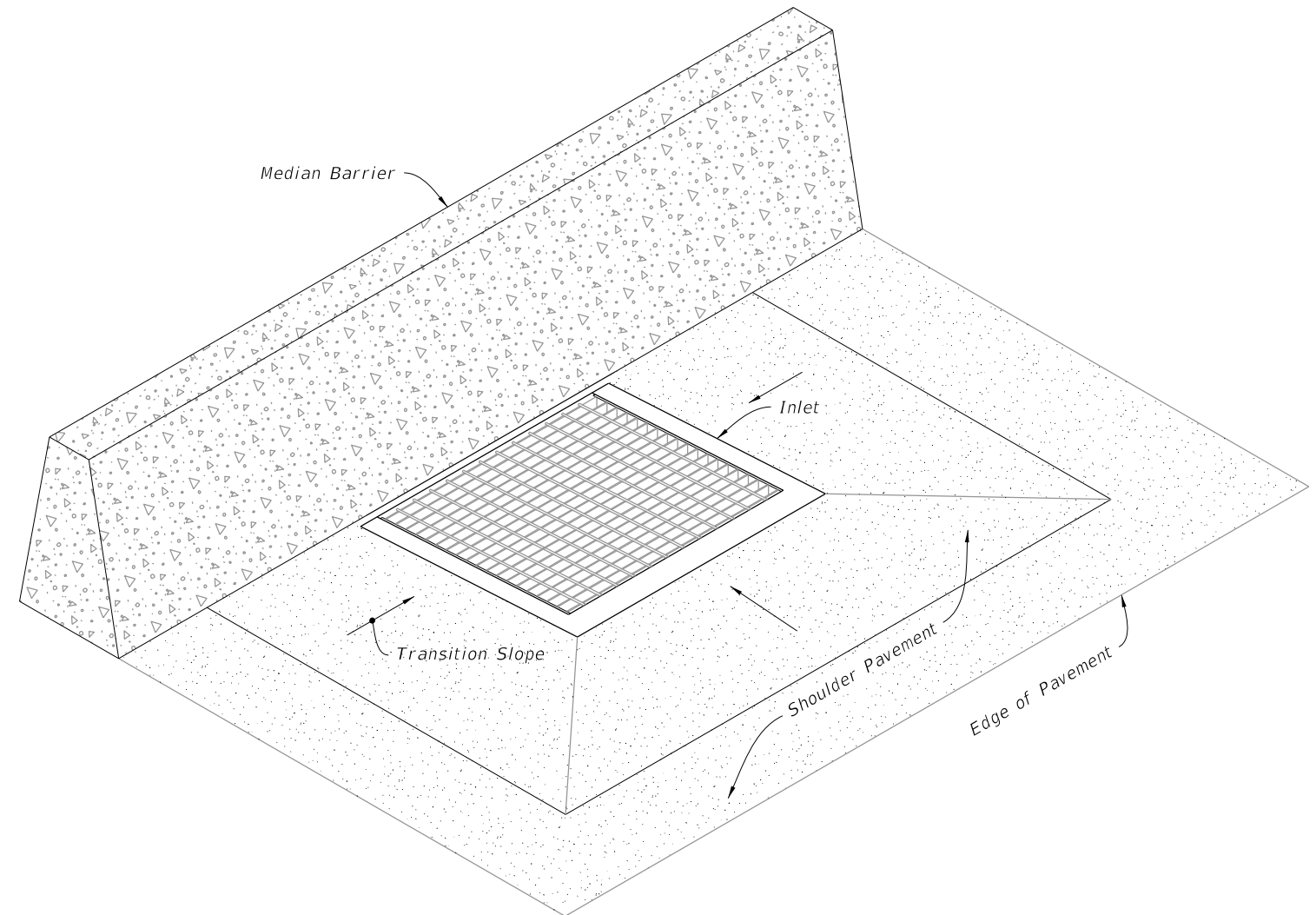
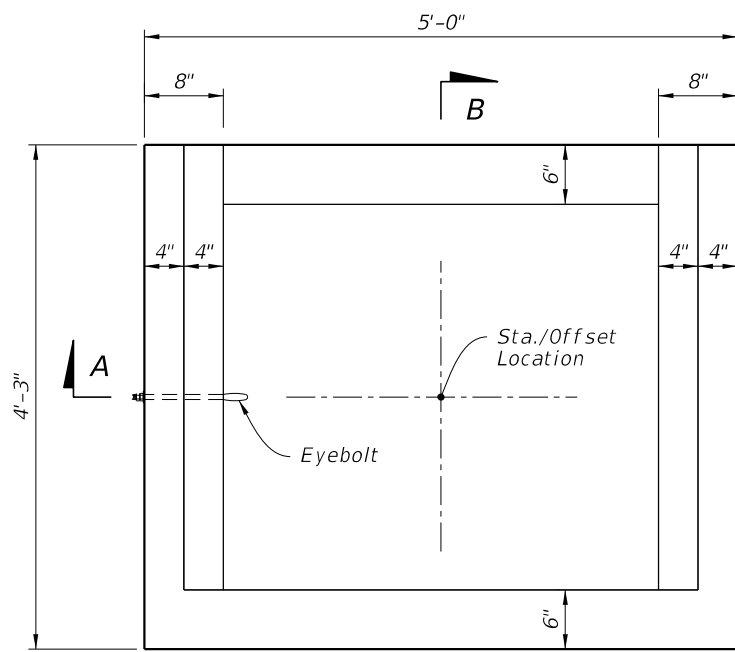

TABLE OF CONTENTS:

Sheet	Description
1	General Notes and Contents
2	Dimensional, Reinforcing, and Steel Grate Details
3	Inlet Collar Dimensional, Reinforcing, and Backwall Plate Details
4	Shoulder Pavement Wrap, Barrier Type Examples, and Structure Bottoms

ADJACENT BARRIER INLET
(Shoulder Barrier Similar)

10/3/2023 11:38:50 AM



PLAN

NOTES:

1. See Sections E-E, F-F, and G-G on Sheet 3 for reinforcing details.
2. Construction joints permitted between these limits. See Index 425-001 for minimum dimensions.
3. Field Installation: When clearance (C) exceeds $\frac{5}{8}$ " weld a one-piece round bar (roller bar) to the end of the cross bars and end band angles to reduce the clearance (C) to $\frac{5}{8}$ " or less. After welding the bar, clean bar and damaged grate coating and coat with a coal tar pitch varnish.

TABLE 1: HORIZONTAL WALL REINFORCING SCHEDULE

WALL DEPTH	SCHEDULE	AREA (in. ² /ft.)	MAX. SPACING	
			BAR	WWR
0'-5'	A12	0.20	12"	8"
5'-10'	A6	0.20	6"	5"
10'-15'	A4	0.20	4"	3"
10'-15'	B5.5	0.24	5½"	5"

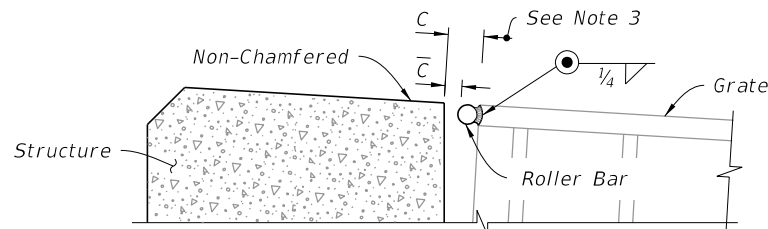

DETAIL "A"

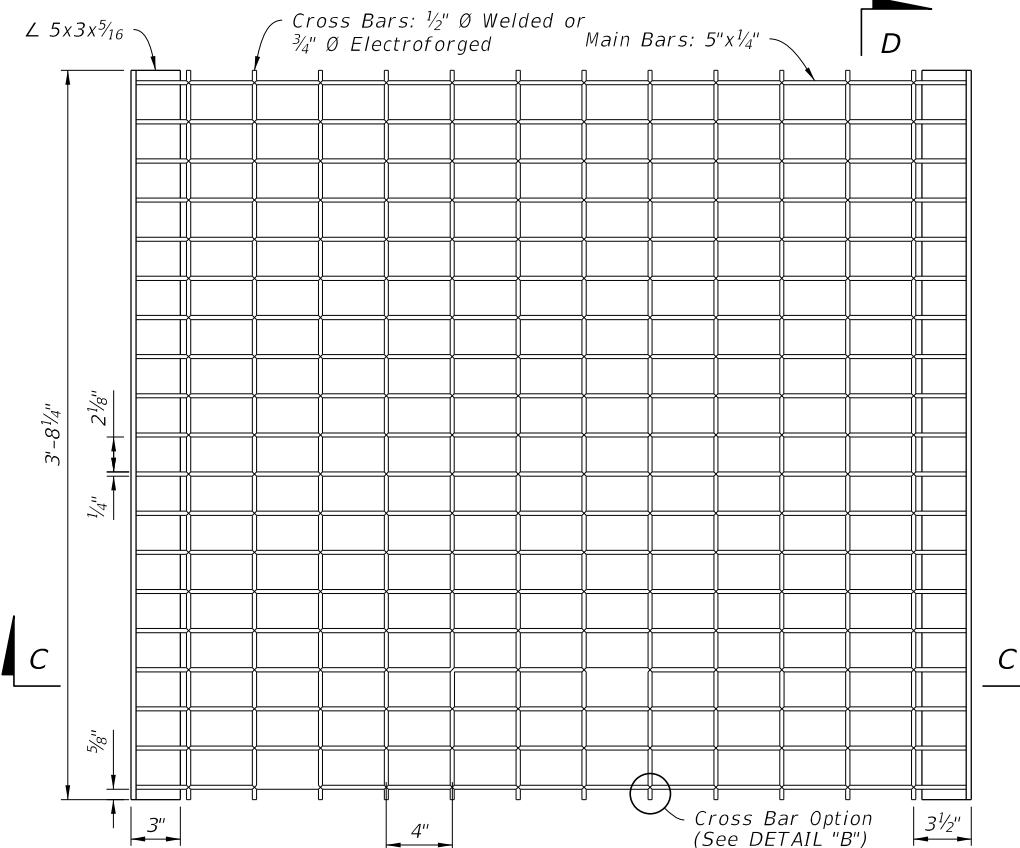

PLAN

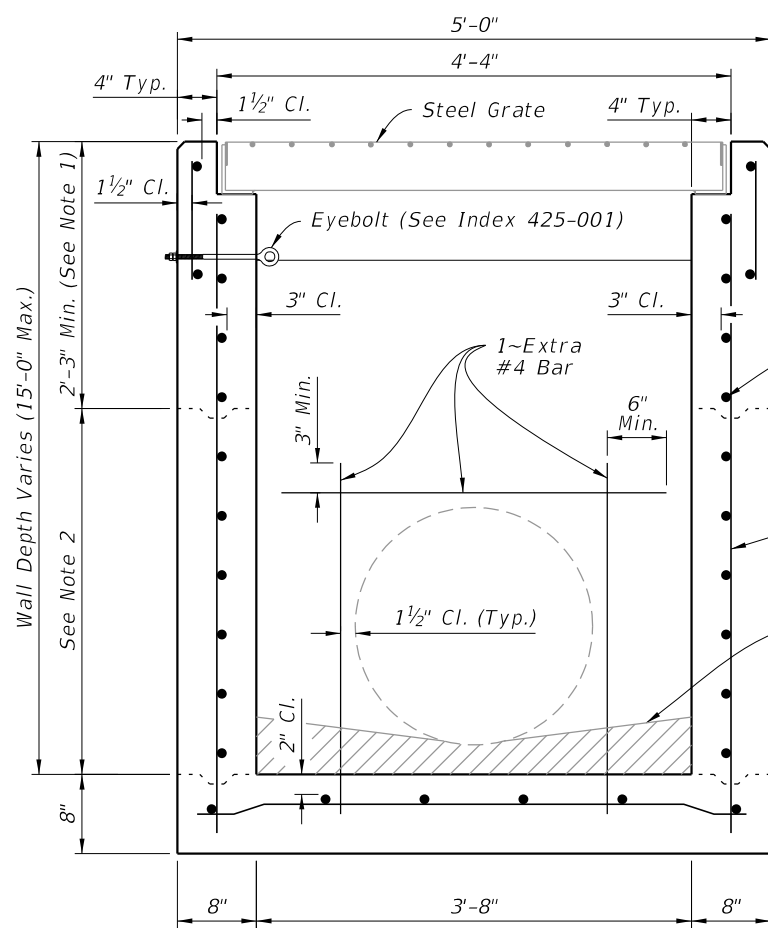

SECTION A-A
(Pipe Opening Shown)

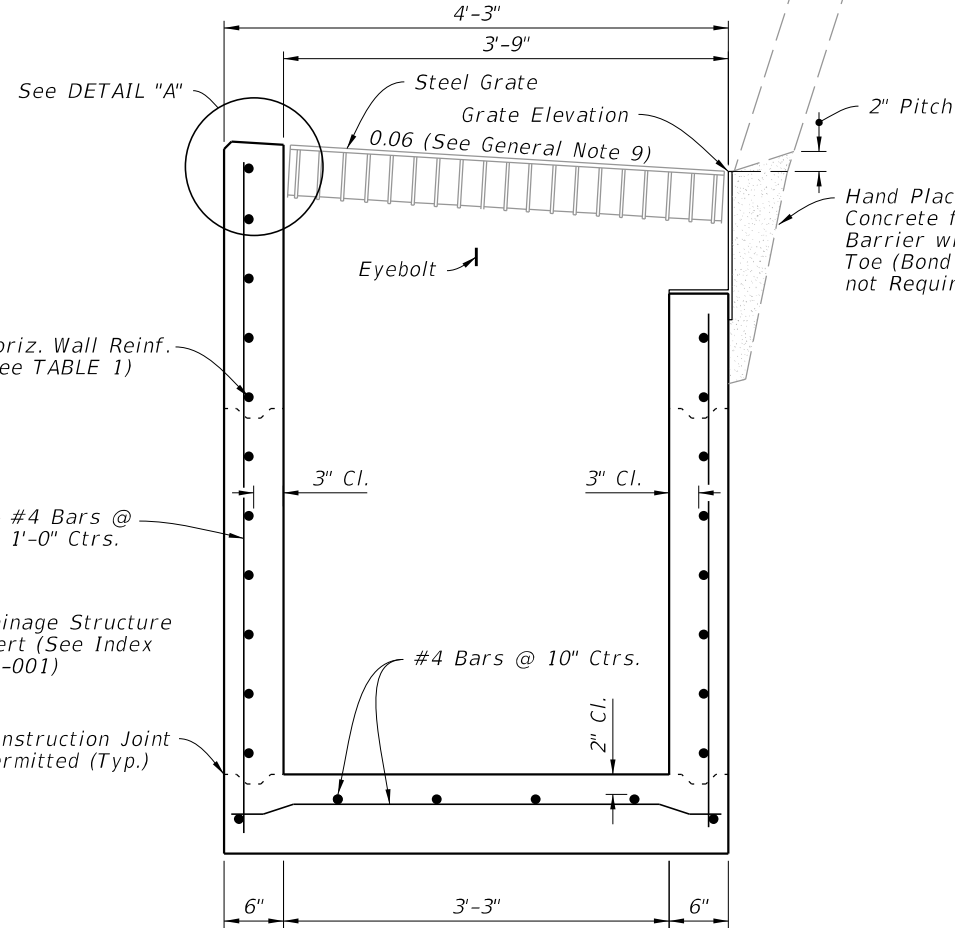

SECTION B-B
(Pipe Opening Not Shown)

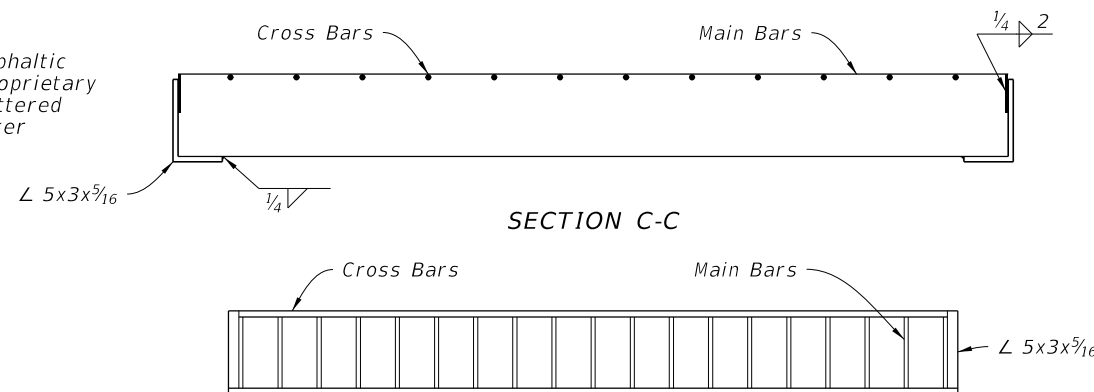

SECTION C-C

SECTION D-D

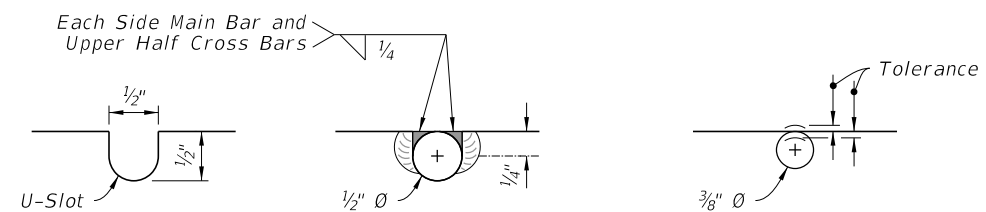

WELDED

ELECTROFORGED

DETAIL "B"

DIMENSIONAL AND REINFORCEMENT

STEEL GRATE

DIMENSIONAL, REINFORCING, AND STEEL GRATE DETAILS

10/3/2023 11:38:56 AM

LAST REVISION 11/01/20	DESCRIPTION:		FY 2024-25 STANDARD PLANS	ADJACENT BARRIER INLET	INDEX 425-031	SHEET 2 of 4
REVISION						

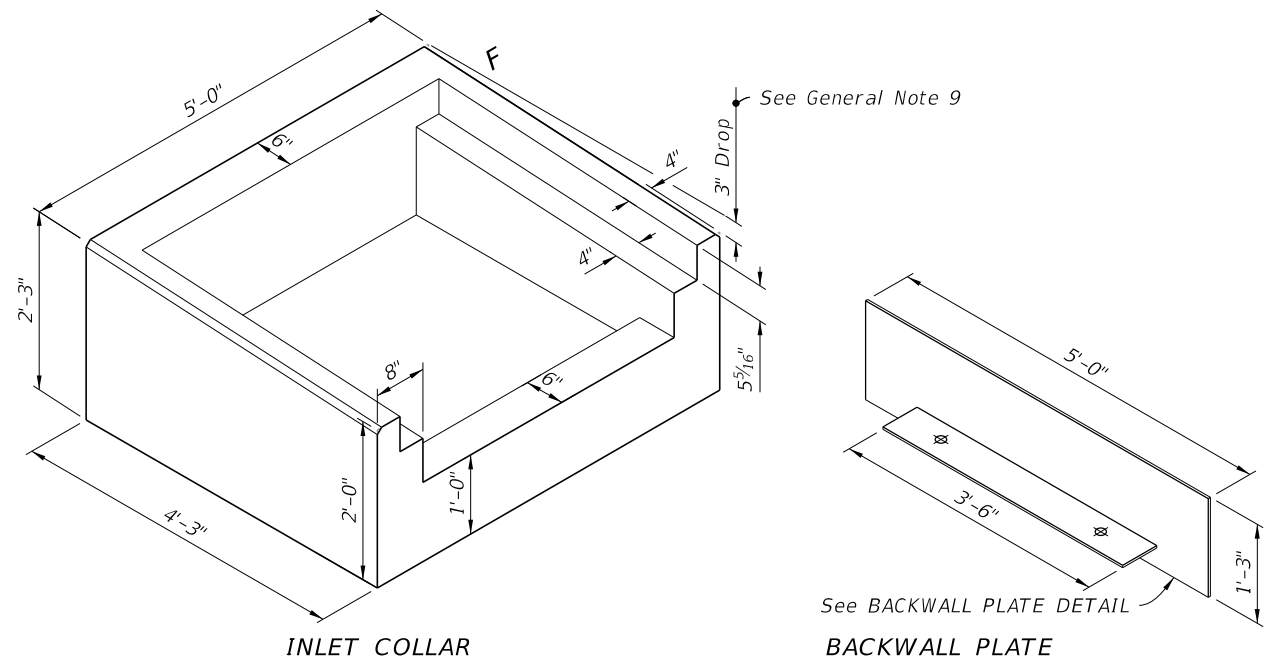

INLET COLLAR

See BACKWALL PLATE DETAIL
BACKWALL PLATE

ISOMETRIC VIEW
(Grate Not Shown)

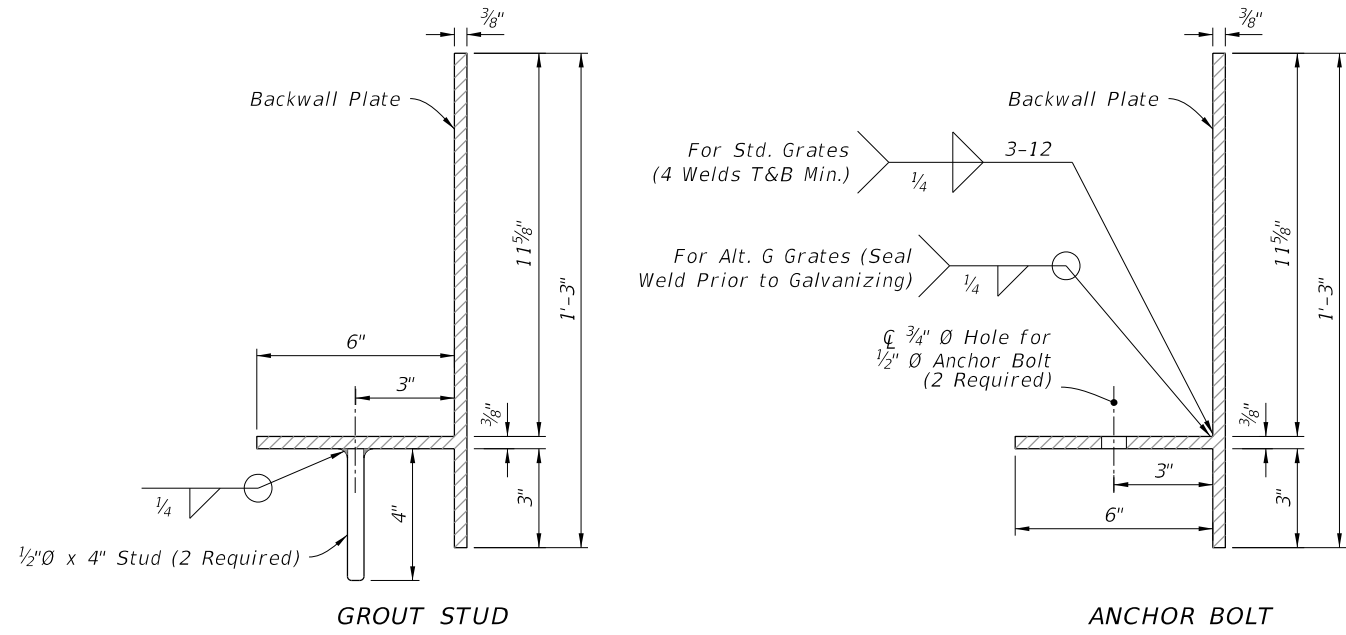

GROUT STUD

ANCHOR BOLT

BACKWALL PLATE DETAIL

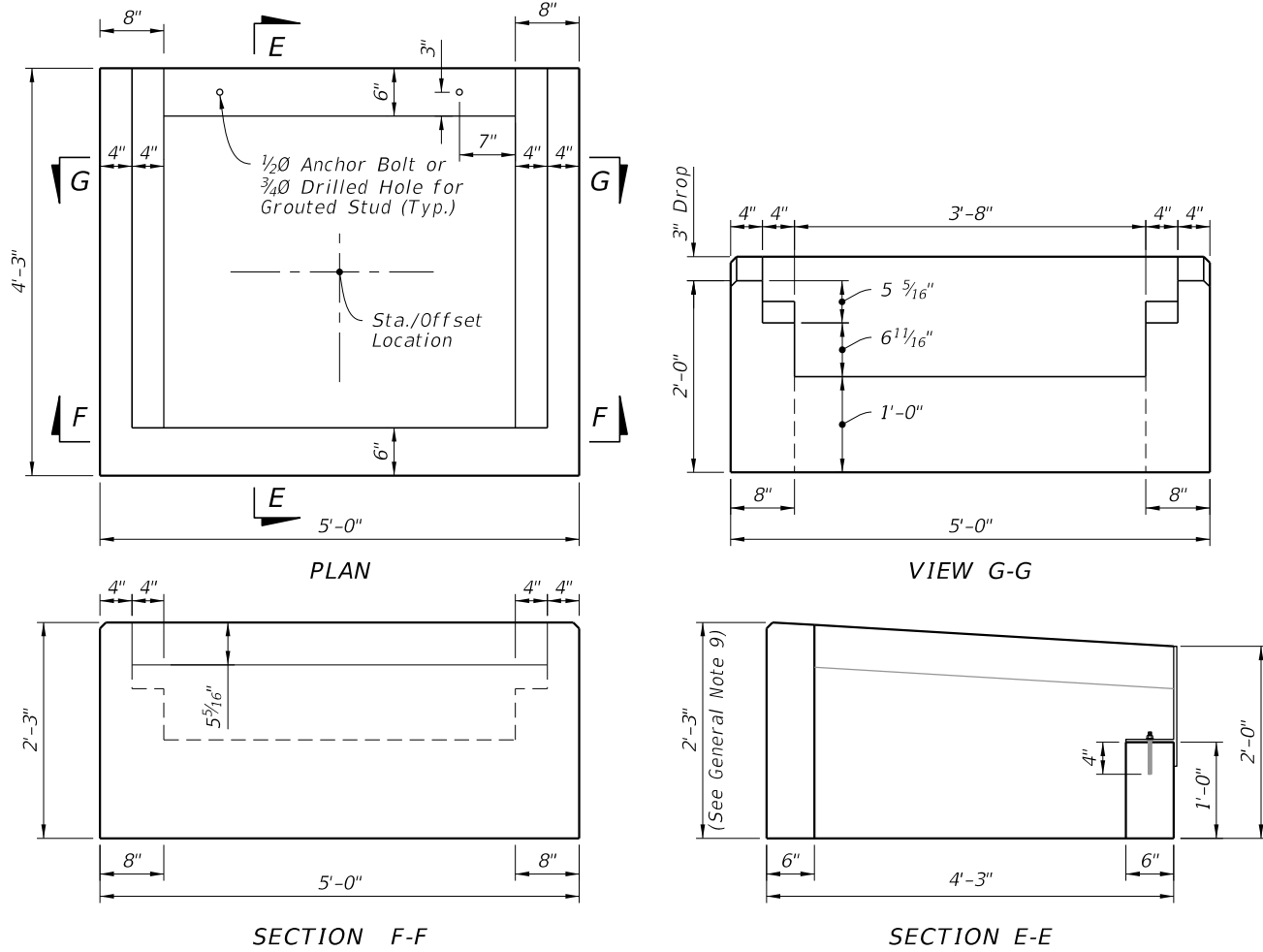

PLAN

VIEW G-G

SECTION F-F

SECTION E-E

DIMENSIONAL DETAILS

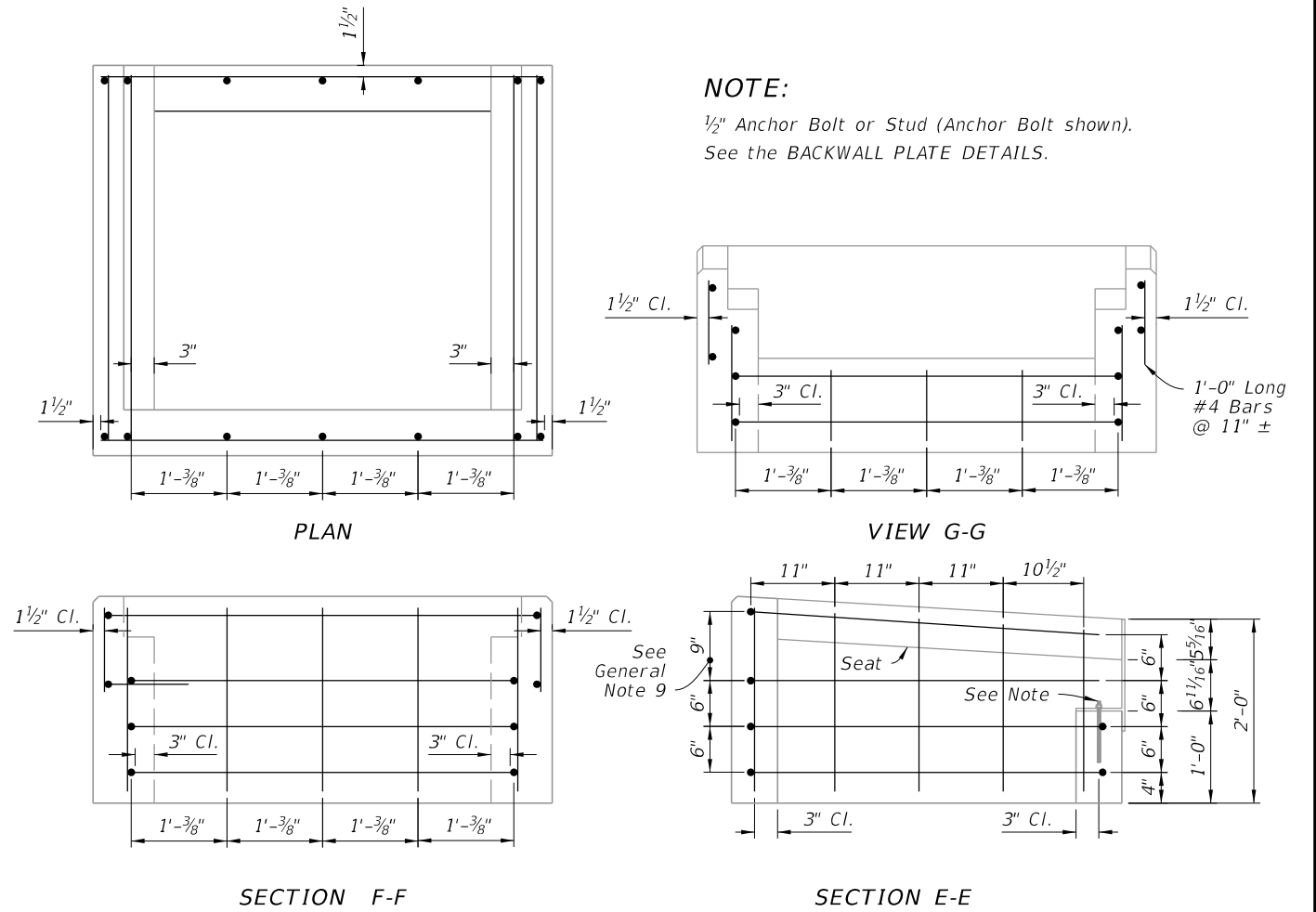

PLAN

VIEW G-G

SECTION F-F

SECTION E-E

REINFORCING DETAILS

INLET COLLAR DIMENSIONAL, REINFORCING, AND BACKWALL PLATE DETAILS

10/3/2023 11:39:03 AM

LAST REVISION 11/01/20	DESCRIPTION:
---------------------------	--------------



FY 2024-25
STANDARD PLANS

ADJACENT BARRIER INLET

INDEX
425-031

SHEET
3 of 4

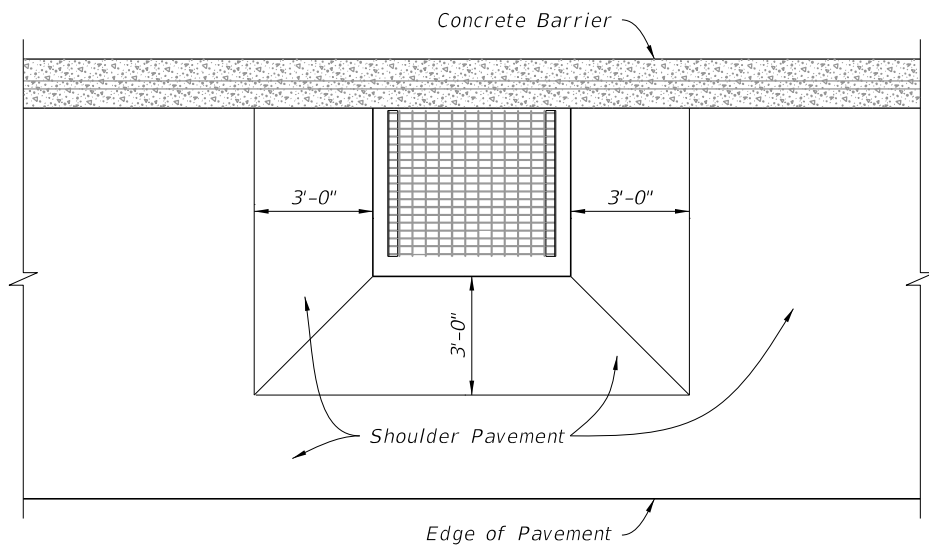

LOW SIDE SUPERELEVATION

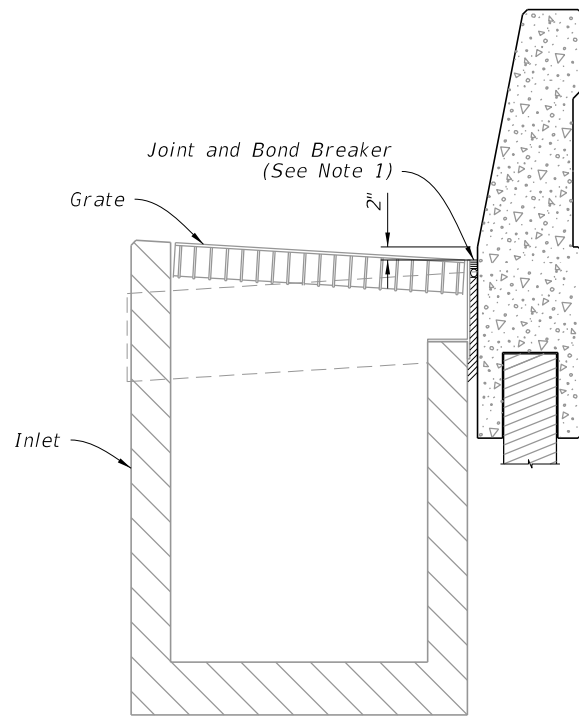

JUNCTION SLAB AND WALL COPING

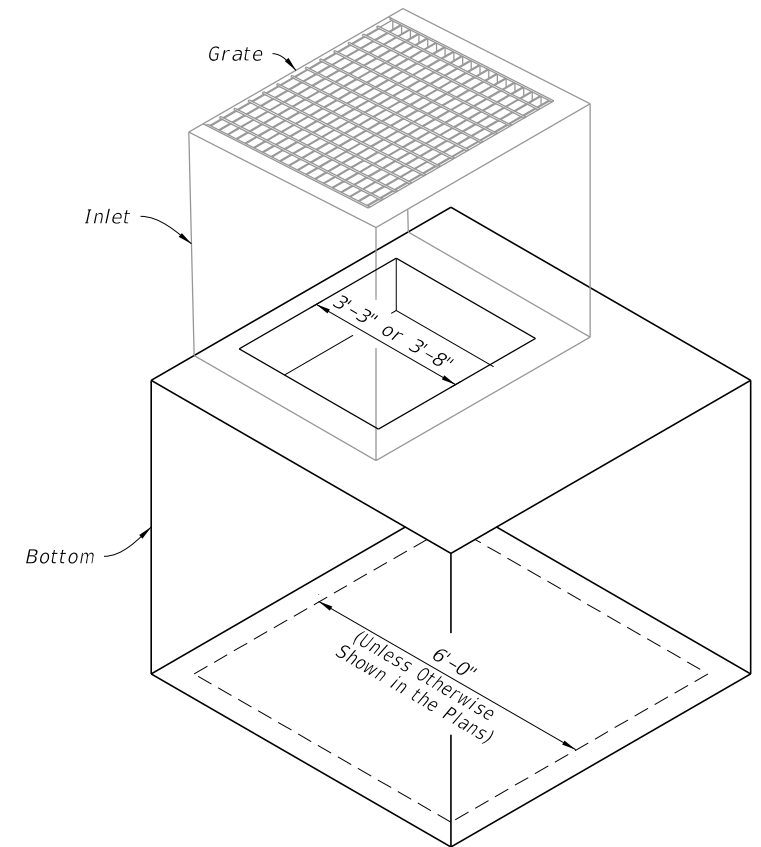

ALTERNATE B STRUCTURE BOTTOM

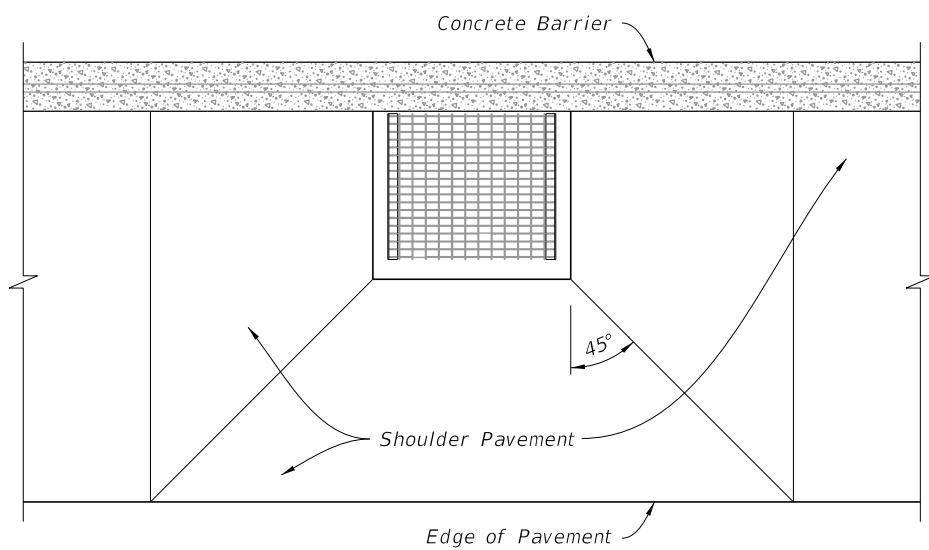

HIGH SIDE TRANSITION

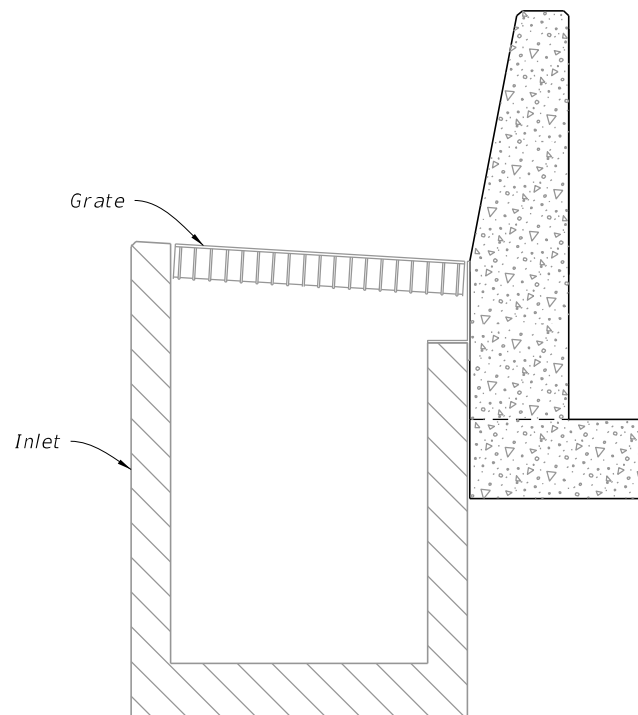

STEM AND FOOTING

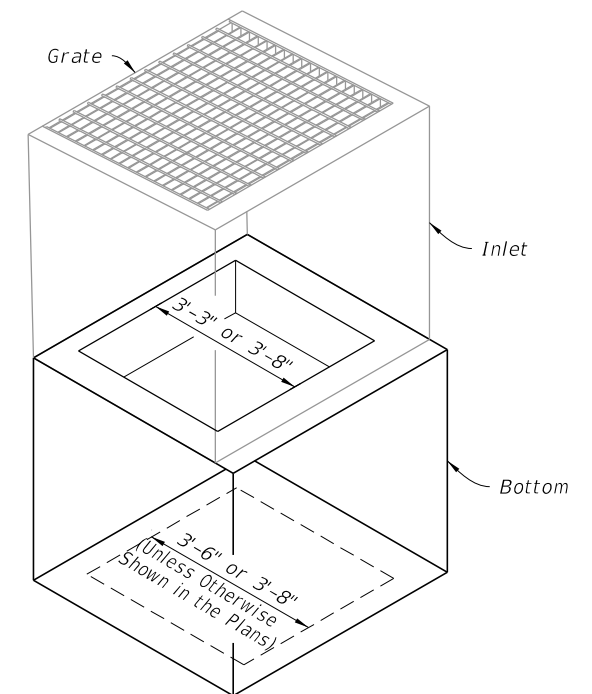

ALTERNATE B STRUCTURE BOTTOM

NOTE: Alt. B Structure Bottom Only. See Index 425-010

===== SUPERELEVATION SHOULDER PAVEMENT WRAP =====

===== BARRIER TYPE EXAMPLES =====

===== INLET WITH STRUCTURE BOTTOM =====

SHOULDER PAVEMENT WRAP, BARRIER TYPE EXAMPLES, AND STRUCTURE BOTTOMS

10/3/2023 11:39:10 AM

LAST REVISION 11/01/20	REVISION	DESCRIPTION:
---------------------------	----------	--------------



FY 2024-25
STANDARD PLANS

ADJACENT BARRIER INLET

INDEX
425-031

SHEET
4 of 4