

**GENERAL NOTES:**

1. Work this Index with Index 425-001 and Index 425-010.
2. Conform the finished grade and slope of the inlet tops with the finished cross slope and grade of the proposed sidewalk and/or border.
3. For inlets constructed on a curve, refer to the plans to determine the radius. Bend steel when necessary.
4. Use Grade 60 reinforcing bars with 1¼" minimum cover unless otherwise shown, see Sheet 6 for equivalent area Welded Wire Reinforcement details.
5. Inlet tops may be either cast-in-place or precast concrete. Conform precast units to the dimensions shown or in accordance with approved shop drawings.
6. Corner fillets are required at inlet opening for precast units or C-I-P units used in conjunction with circular inlet bottoms or skewed rectangular inlet boxes. Finish top of fillets flush with drain throat bottom and match slope.
7. For Type E curb and gutter, transition the shape of the curb over the gutter transition length to match the face of the inlet (Type Ft).
8. Meet the requirements of ASTM A36/A36M with steel used for frames and grates.
9. Use either cast iron grates or steel grates.

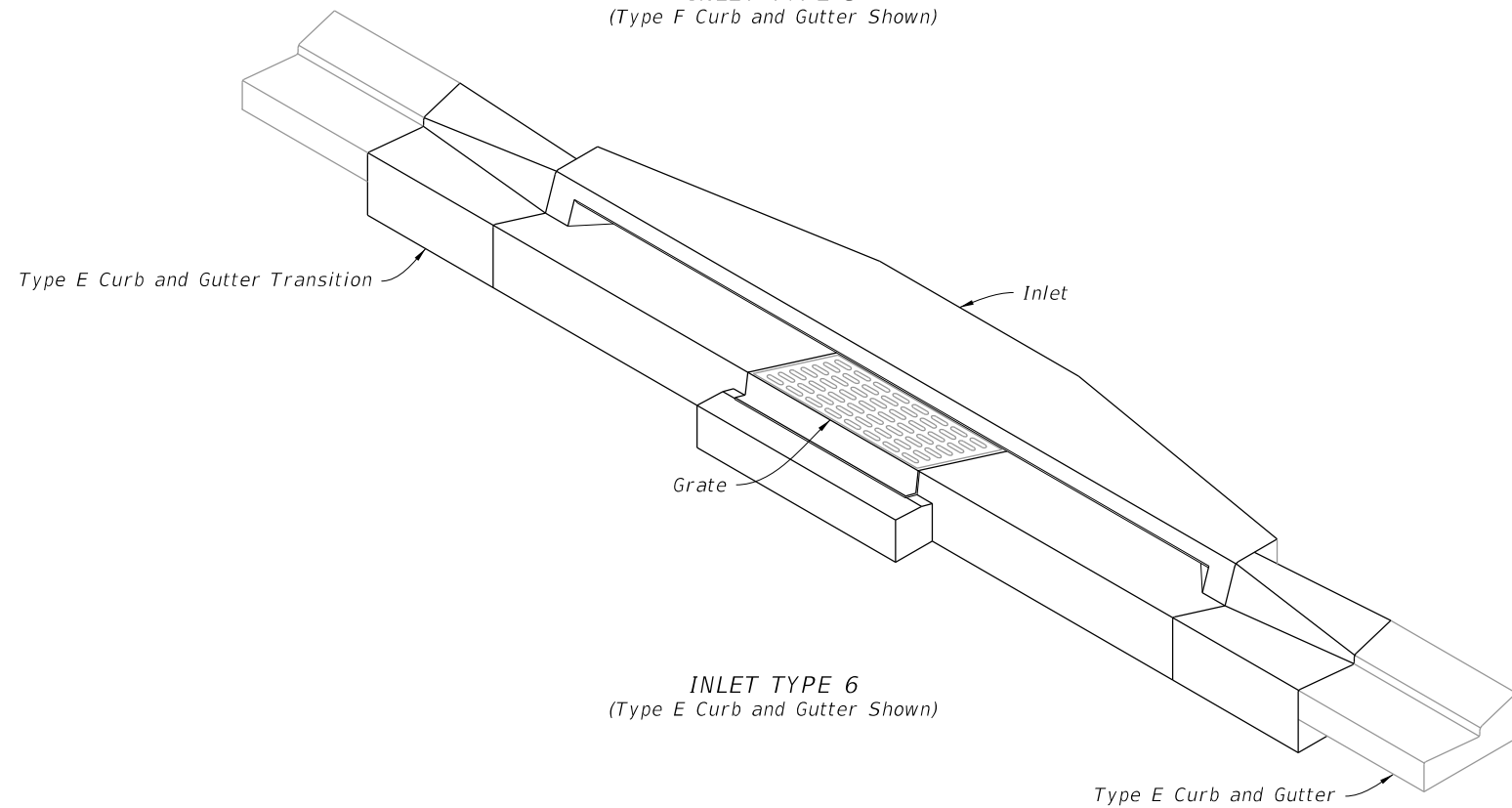
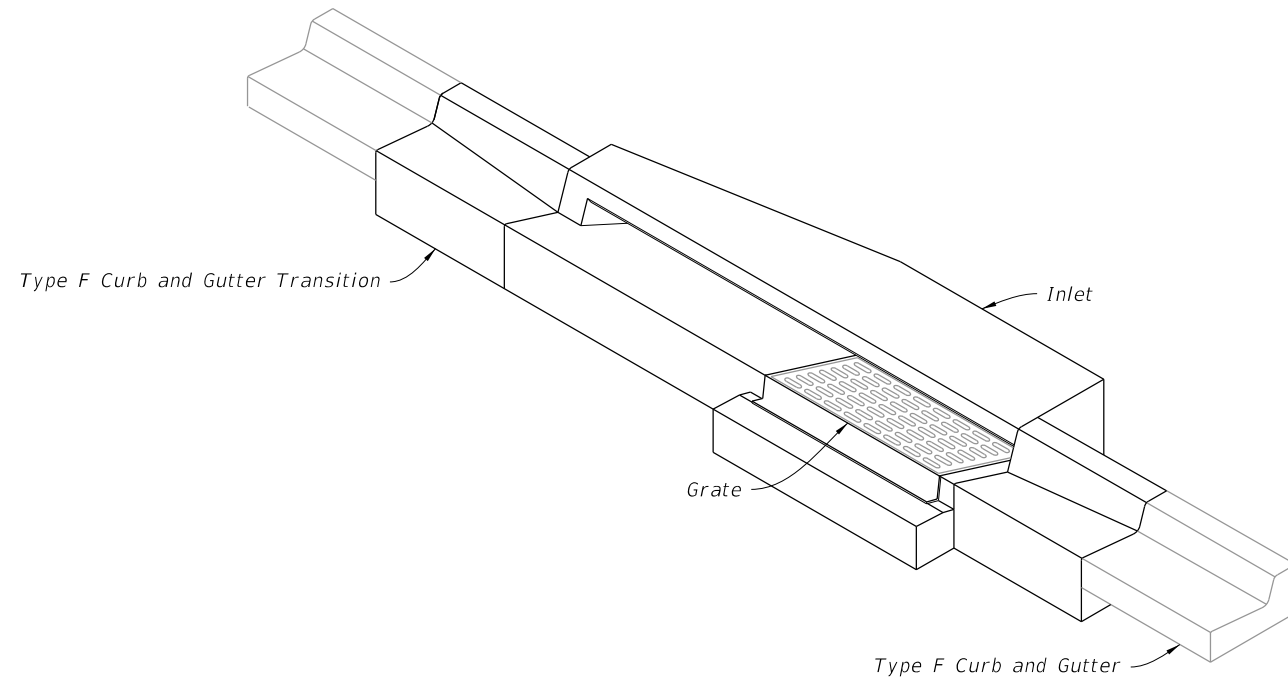
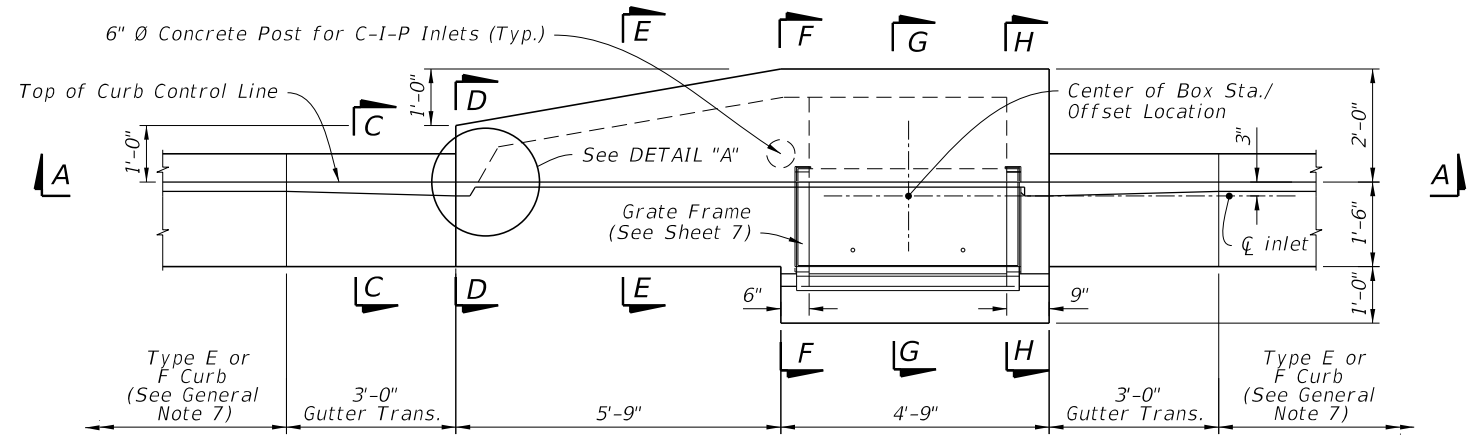

TABLE OF CONTENTS:	
Sheet	Description
1	General Notes and Contents
2	Type 5 and 6 Dimensional Details
3	Type 5 and 6 Reinforcing and Bar Bending Details
4	Precast Dimensional and Reinforcing Details
5	Cast-In-Place Dimensional and Reinforcing Details
6	Alternate Welded Wire Reinforcing (WWR) Details
7	Grate, Anchor, and Grouting Details

CURB INLETS TOPS

9/28/2023 1:51:10 PM



PLAN

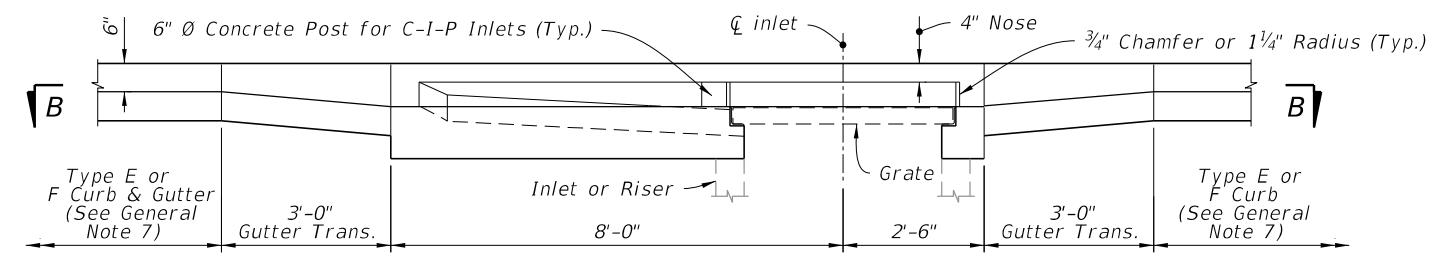

ELEVATION

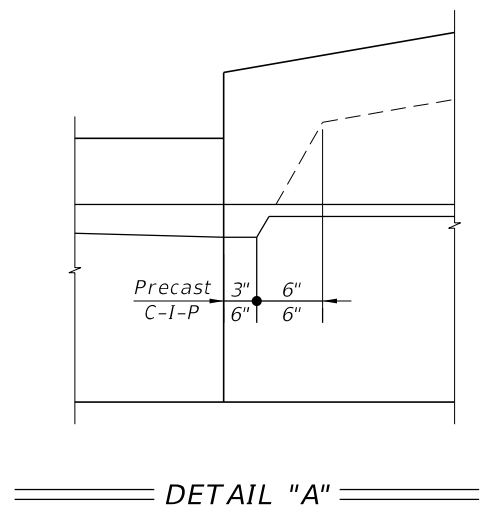

TYPE 5 DIMENSIONAL DETAILS

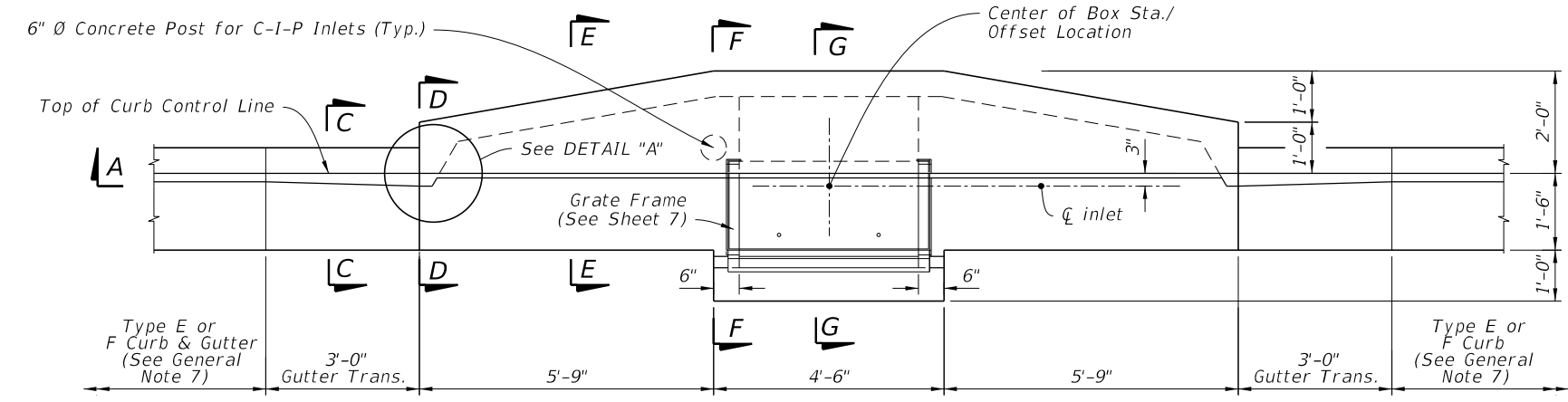

PLAN

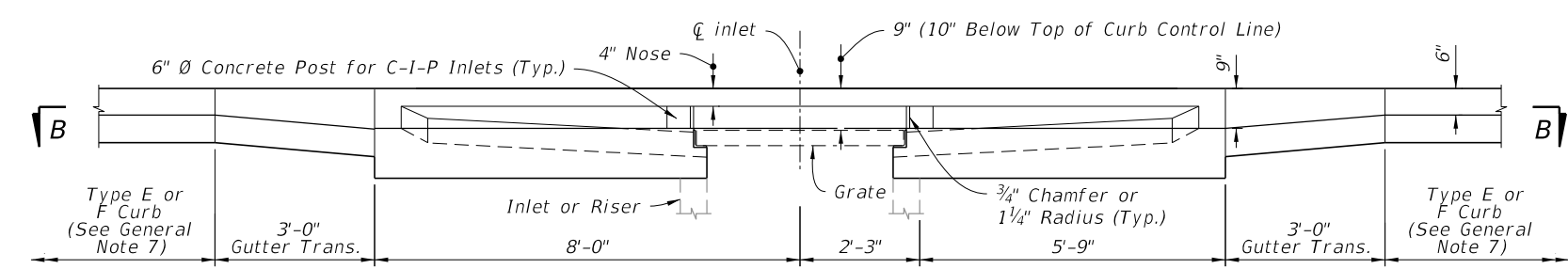

ELEVATION

TYPE 6 DIMENSIONAL DETAILS

TYPE 5 AND 6 DIMENSIONAL DETAILS

9/28/2023 1:51:14 PM

LAST REVISION 11/01/20	REVISION	DESCRIPTION:	 FY 2024-25 STANDARD PLANS	CURB INLET TOP TYPES 5 AND 6	INDEX 425-021	SHEET 2 of 7
---------------------------	----------	--------------	--	------------------------------	------------------	-----------------

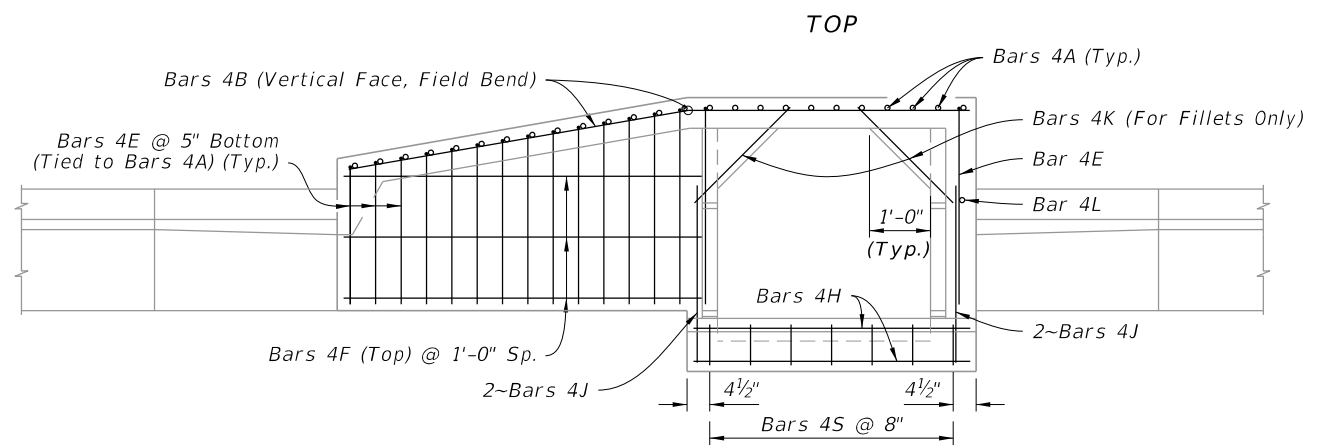
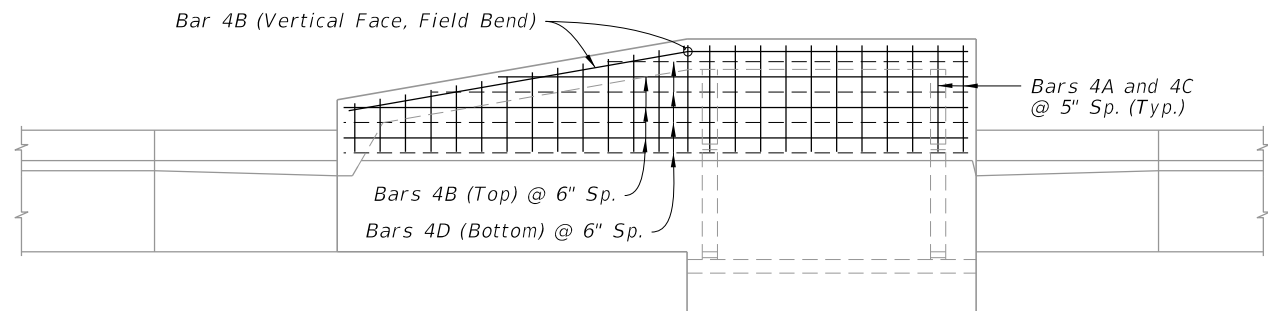

TYPE 5 REINFORCING DETAILS

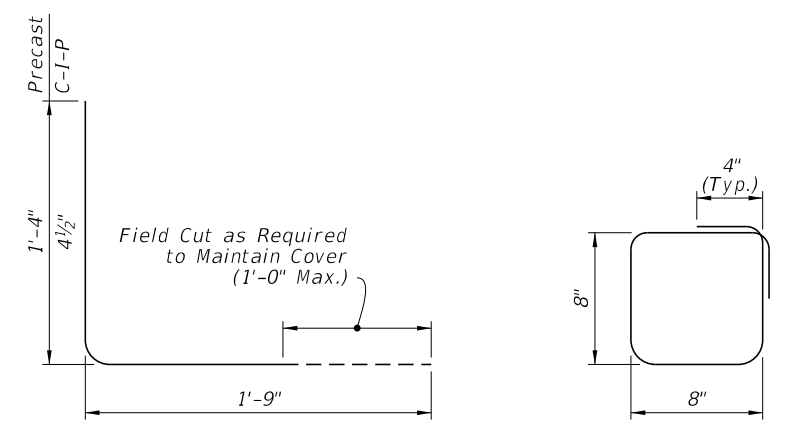

BAR 4A

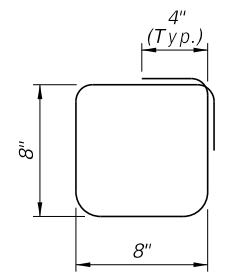

BAR 4S

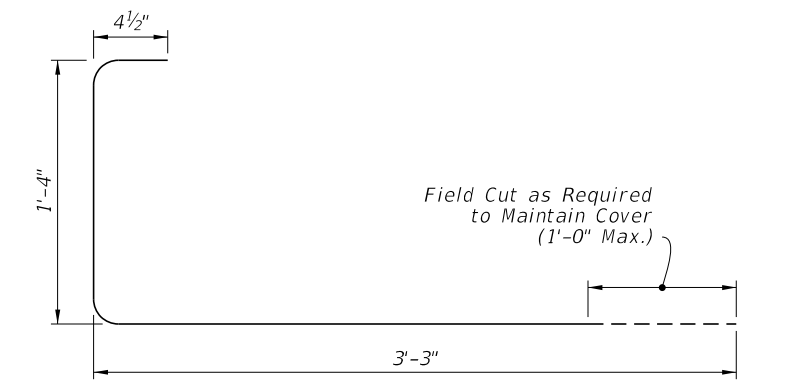

BAR 4E

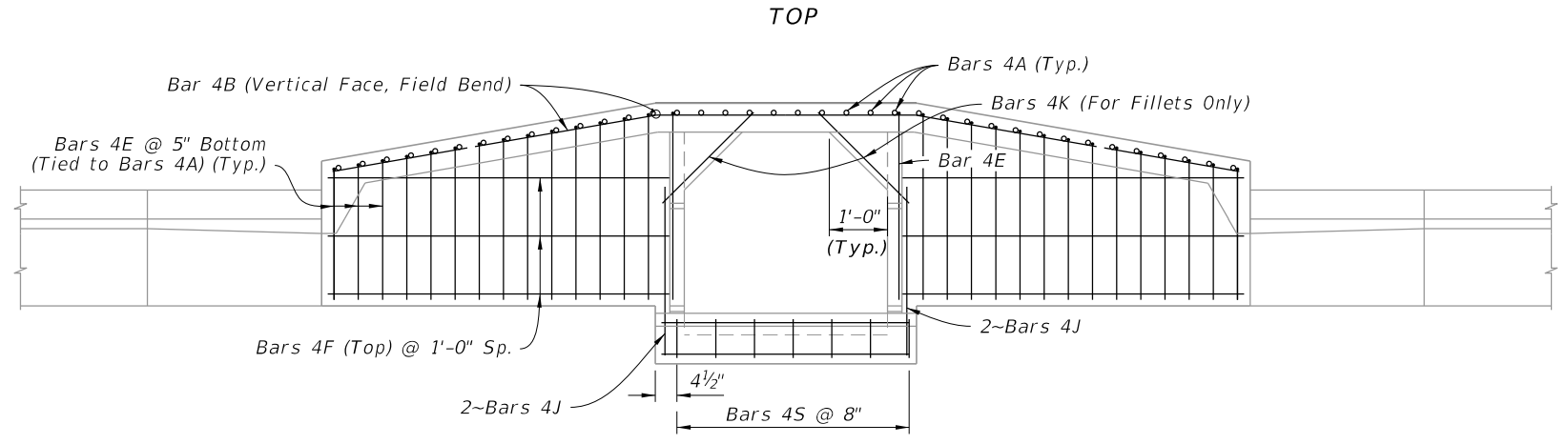
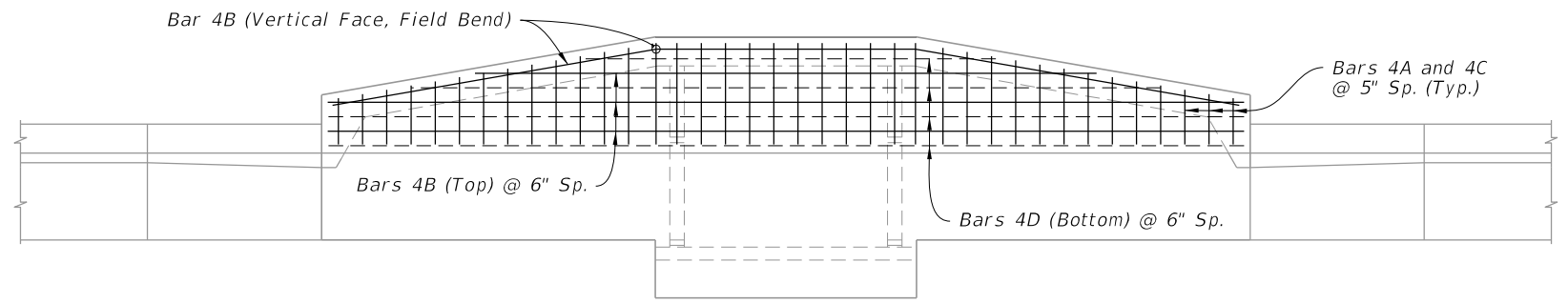

TYPE 6 REINFORCING DETAILS

BILL OF REINFORCING STEEL					
MARK	SIZE	TYPE 5 INLET		TYPE 6 INLET	
		NO.	LENGTH	NO.	LENGTH
A (Precast)	4	25	3'-1"	38	3'-1"
A (C-I-P)	4	25	2'-1 1/2"	38	2'-1 1/2"
B	4	6	10'-3"	6	15'-9"
C	4	25	11" to 1'-11"	38	11" to 1'-11"
D	4	4	10'-3"	4	15'-9"
E	4	16	4'-11 1/2"	30	4'-11 1/2"
F	4	3	6'-0"	6	6'-0"
H	4	4	4'-6"	4	4'-6"
J	4	4	3'-0"	4	3'-0"
K (Fillet)	4	2	2'-3"	2	2'-3"
L (Precast)	4	1	1'-4"	0	---
L (C-I-P)	4	10	1'-4"	9	1'-4"
S	4	7	3'-2"	7	3'-2"

- NOTES:**
- All bar dimensions in the bending diagrams are out to out.
  - Bars 4A and 4E may be combined into a single bar.
  - Welded Wire Reinforcement consists of smooth or deformed wire meeting the requirements of Specification 931.

TYPE 5 AND 6 REINFORCING AND BAR BENDING DETAILS

9/28/2023 1:51:19 PM

LAST REVISION 11/01/20	REVISION	DESCRIPTION:	 FY 2024-25 STANDARD PLANS	CURB INLET TOP TYPES 5 AND 6	INDEX 425-021	SHEET 3 of 7
---------------------------	----------	--------------	---	------------------------------	------------------	-----------------



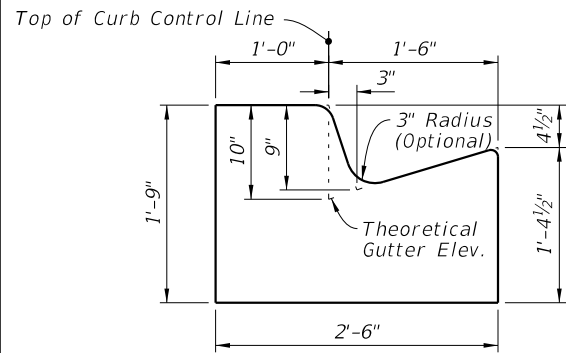

OPTION A

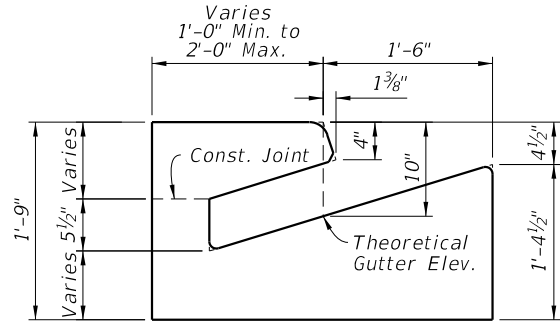

OPTION A

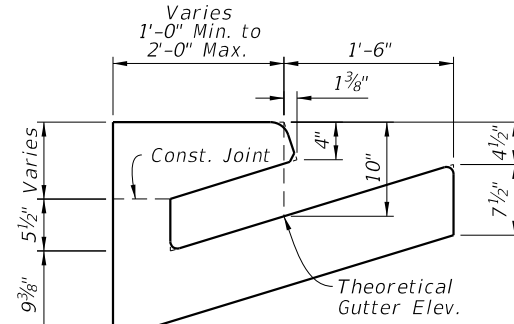

OPTION B

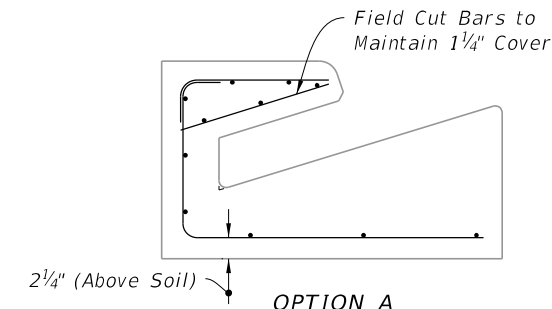

OPTION A

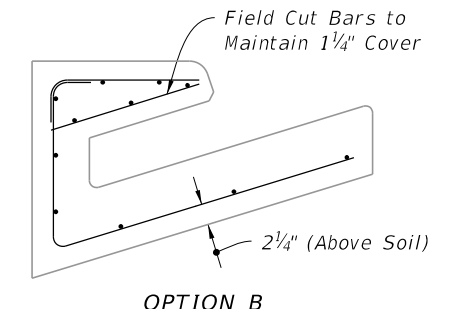

OPTION B

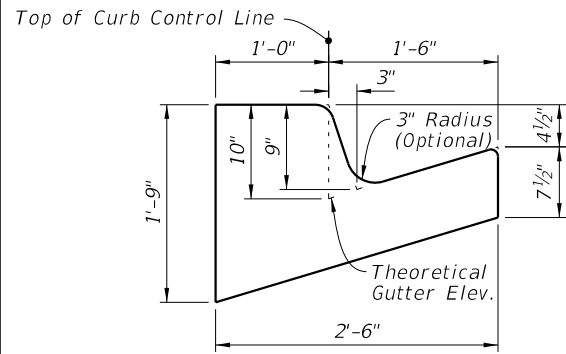

OPTION B  
SECTION D-D

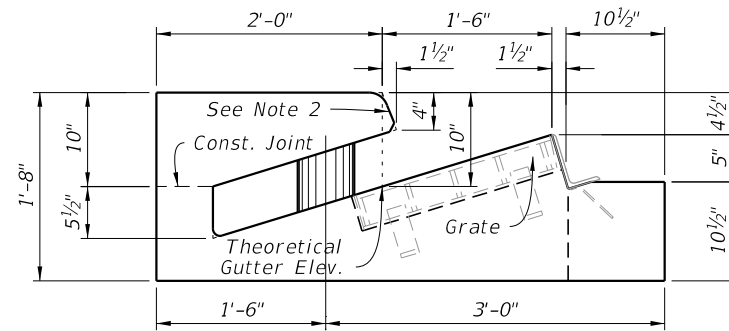

SECTION F-F

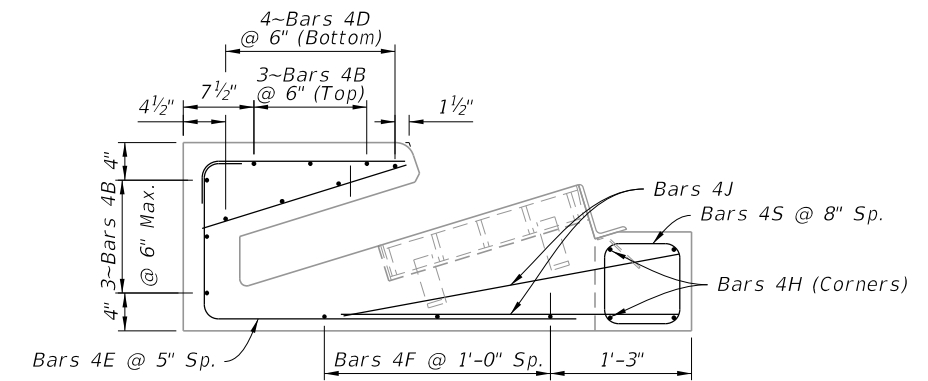

SECTION F-F

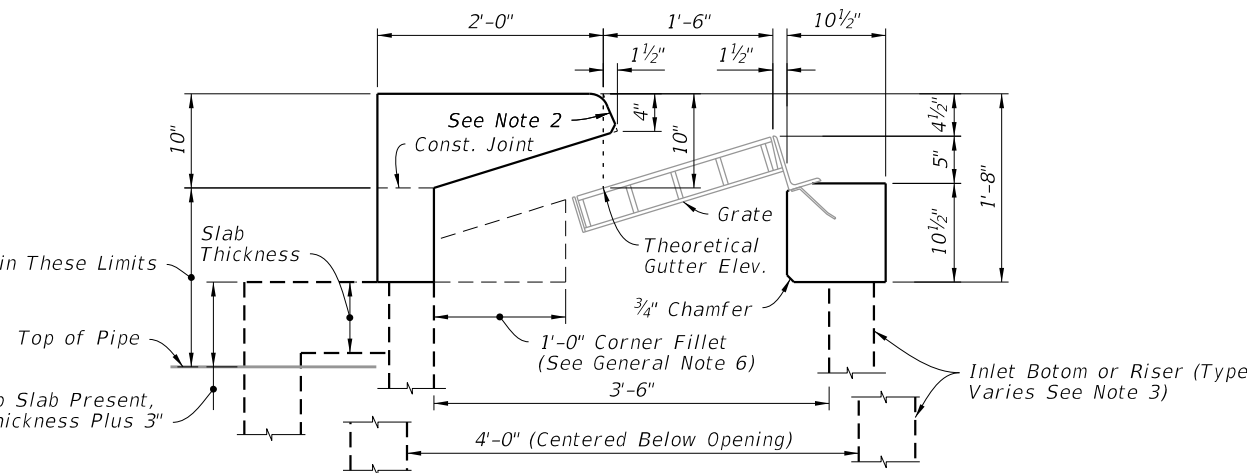

SECTION G-G

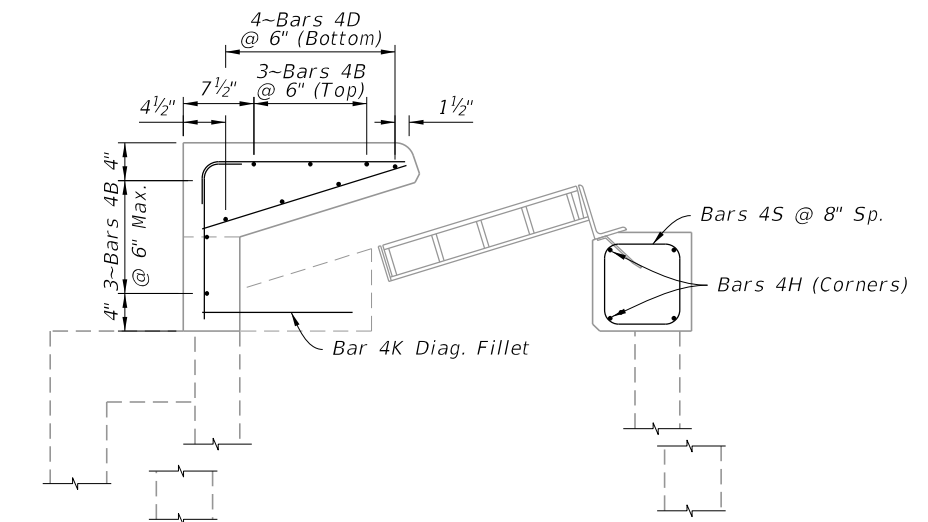

SECTION G-G

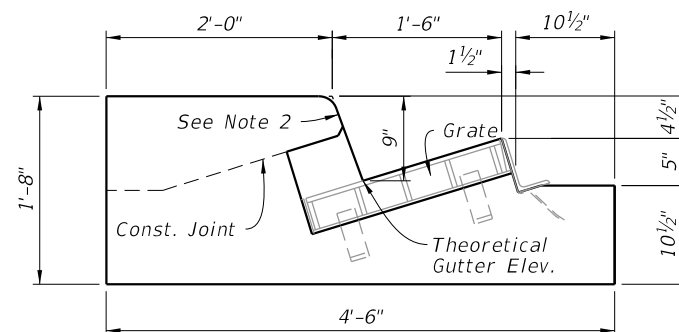

SECTION H-H

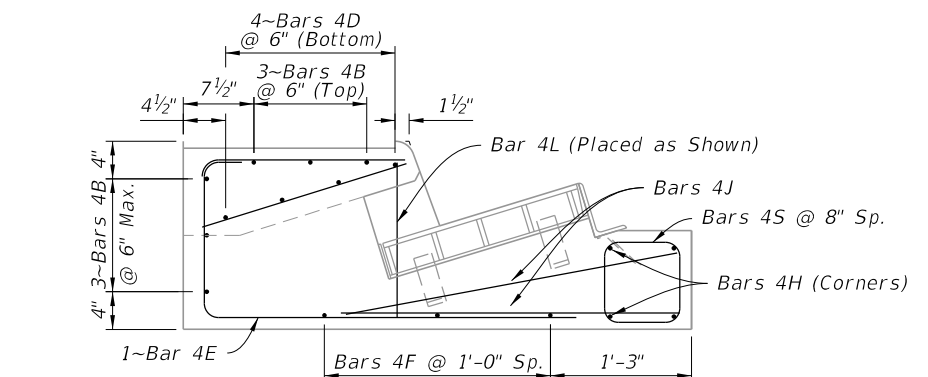

SECTION H-H

**NOTES:**

1. For location of Sections D-D thru H-H see Sheet 2.
2. Match slope of adjacent curb with 2" top radius and 3/4" bottom chamfer of 1/4" radius.
3. See Plans for bottom and riser type.

**DIMENSIONAL DETAILS**

**REINFORCING DETAILS**

**CAST-IN-PLACE DIMENSIONAL AND REINFORCING DETAILS**

9/28/2023 1:51:27 PM

LAST REVISION 11/01/20	REVISION	DESCRIPTION:		FY 2024-25 STANDARD PLANS	CURB INLET TOP TYPES 5 AND 6	INDEX 425-021	SHEET 5 of 7
---------------------------	----------	--------------	--	------------------------------	------------------------------	------------------	-----------------

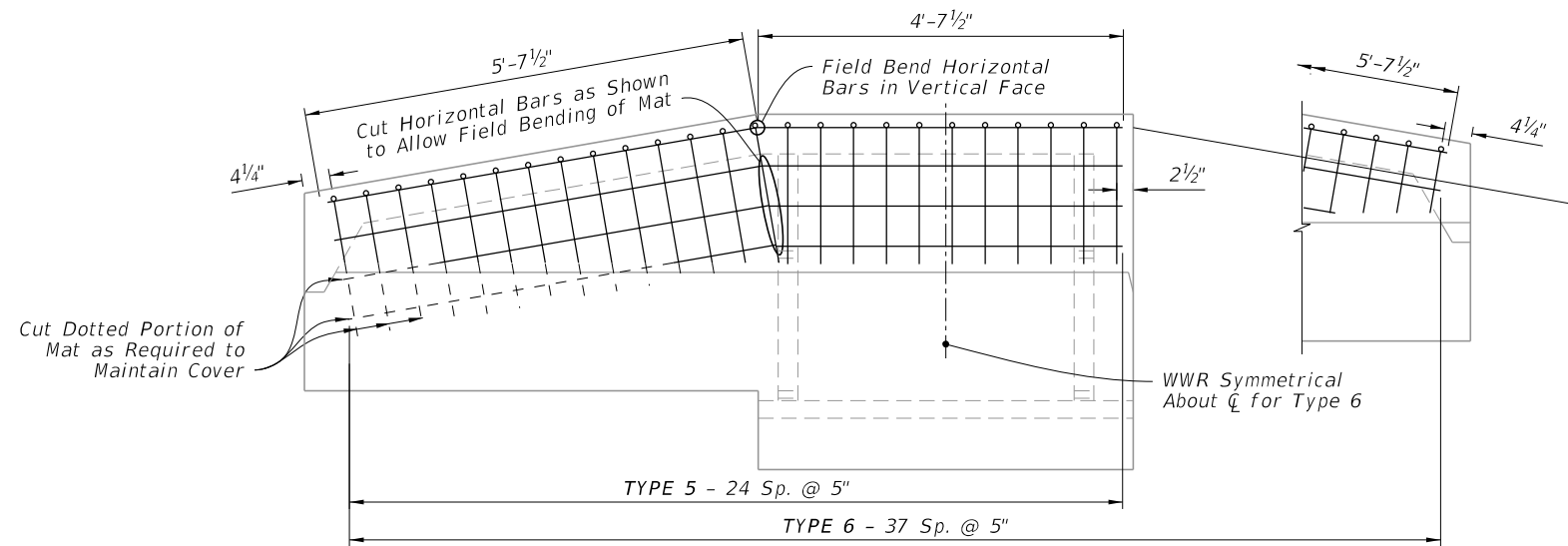

PIECE - 1 PLACEMENT SCHEMATIC

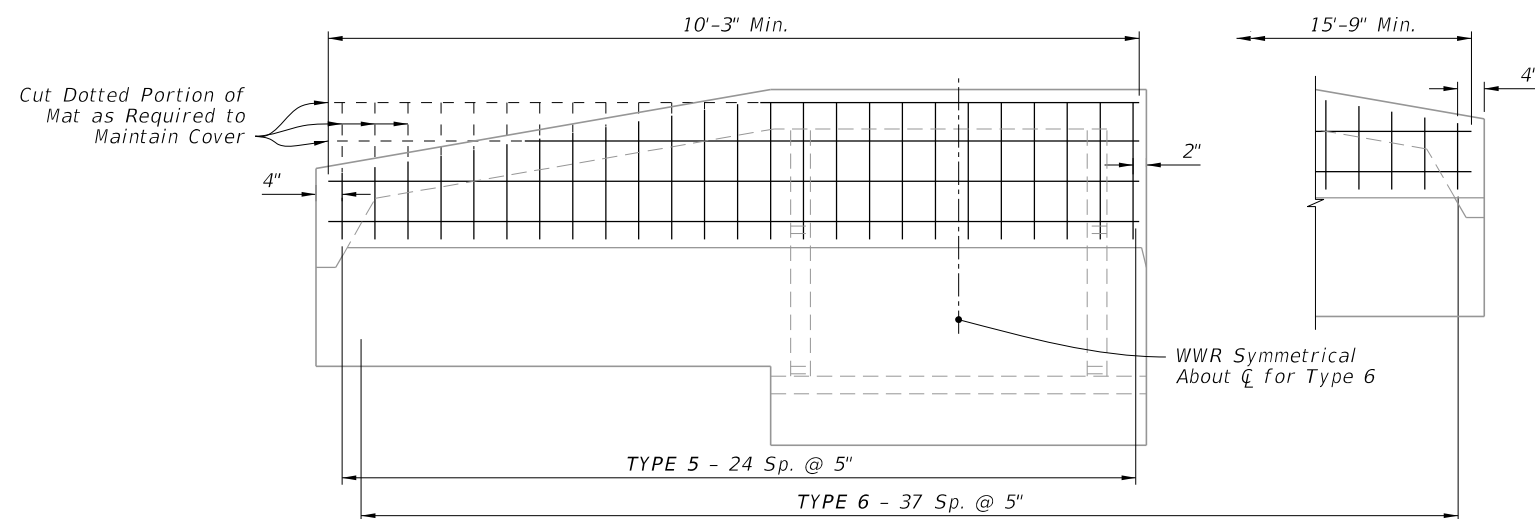

PIECE - 2 PLACEMENT SCHEMATIC

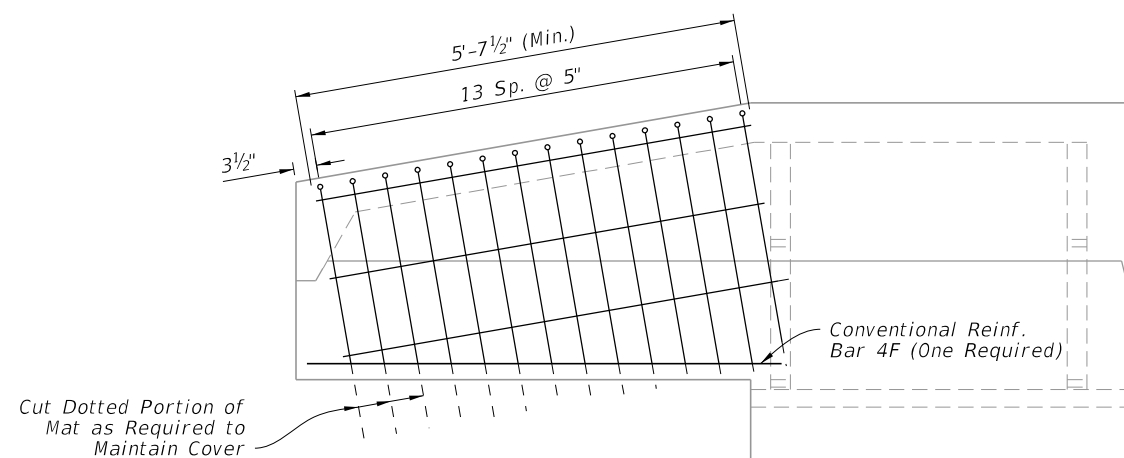

PIECE - 3 PLACEMENT SCHEMATIC

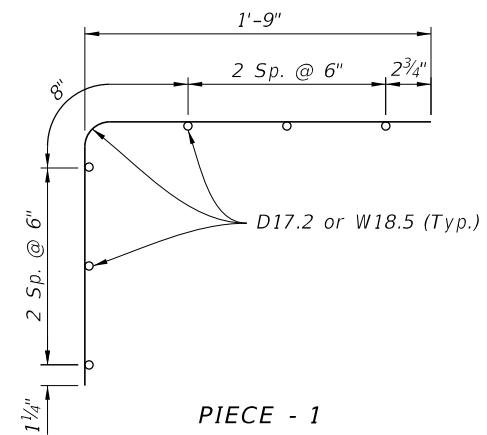

PIECE - 1

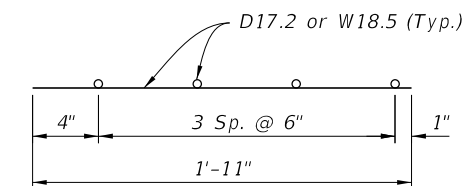

PIECE - 2

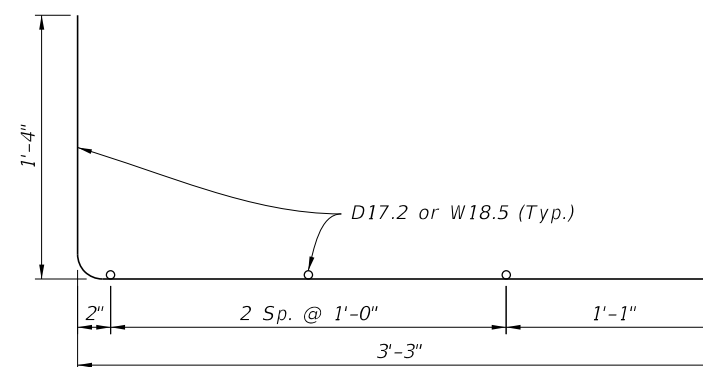

PIECE - 3

WELDED WIRE REINFORCING DETAILS

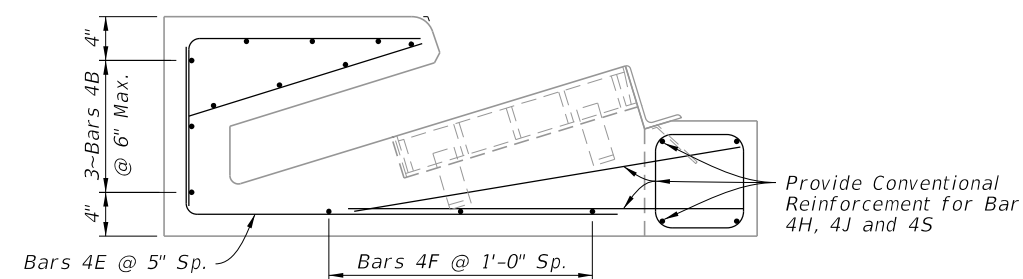

TYPICAL SECTION

NOTES:

1. All bar dimensions in the bending diagrams are out to out.
2. Welded Wire Reinforcement consists of Smooth or Deformed wire meeting the requirements of Specification 931.

ALTERNATE WELDED WIRE REINFORCING (WWR) DETAILS

9/28/2023 1:51:33 PM

LAST REVISION 11/01/20	DESCRIPTION:
---------------------------	--------------



FY 2024-25  
STANDARD PLANS

CURB INLET TOP TYPES 5 AND 6

INDEX  
425-021

SHEET  
6 of 7

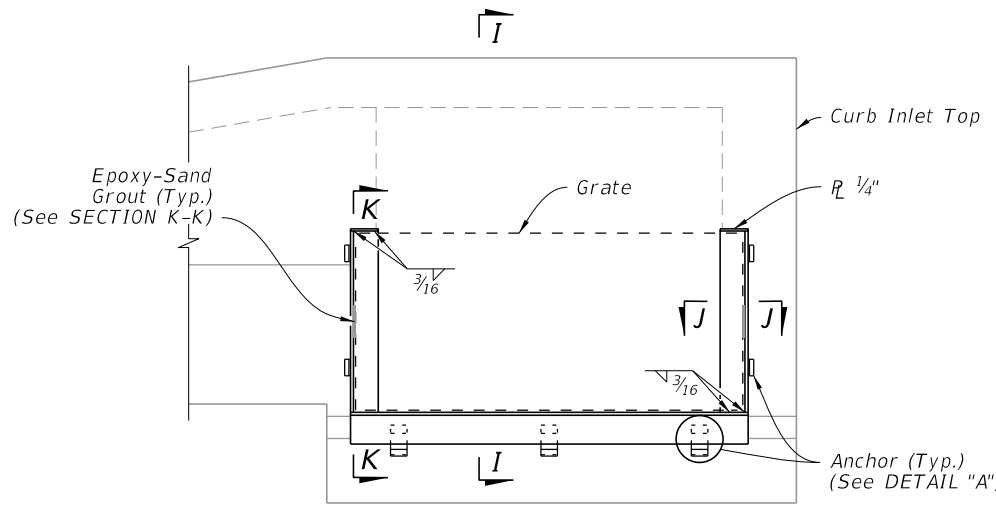

FRAME DETAIL

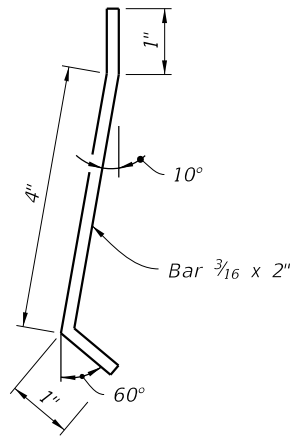

ANCHOR

DETAIL "A"

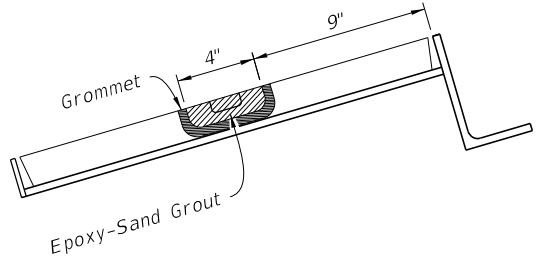

CAST IRON GRATE GROUTING DETAILS

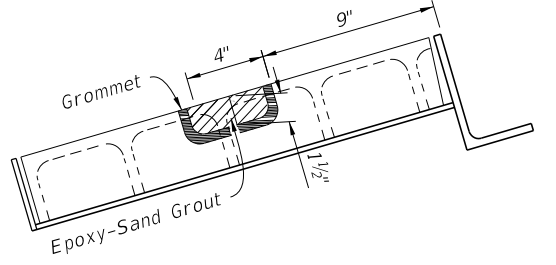

STEEL GRATE GROUTING DETAILS

SECTION K-K

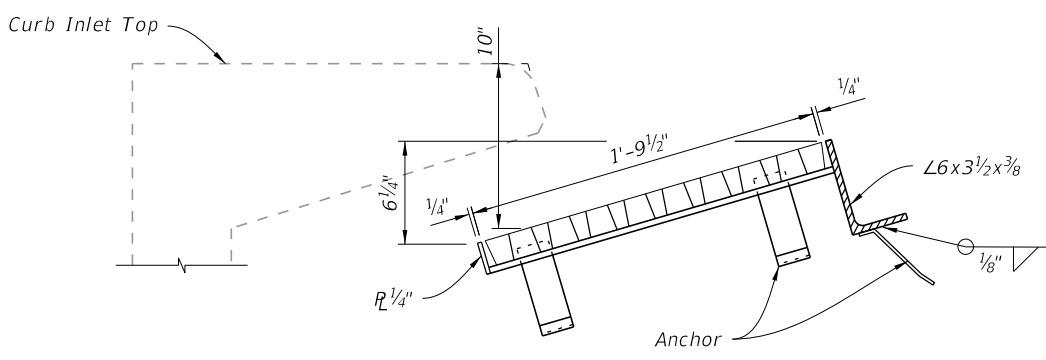

SECTION I-I

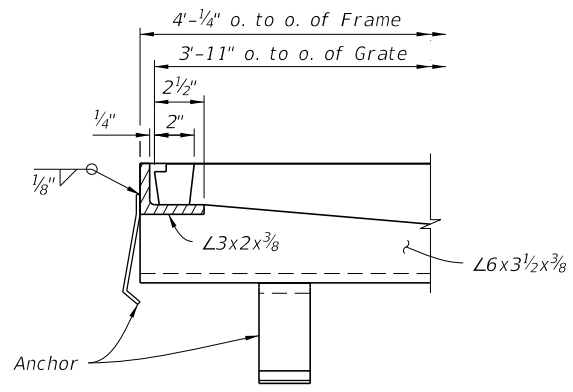

SECTION J-J

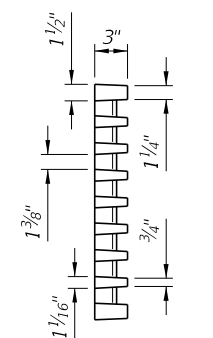

SECTION M-M

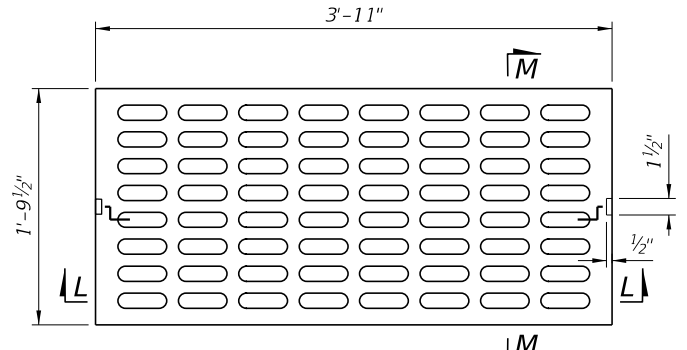

TOP

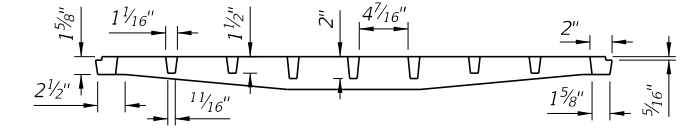

SECTION L-L

CAST IRON GRATE

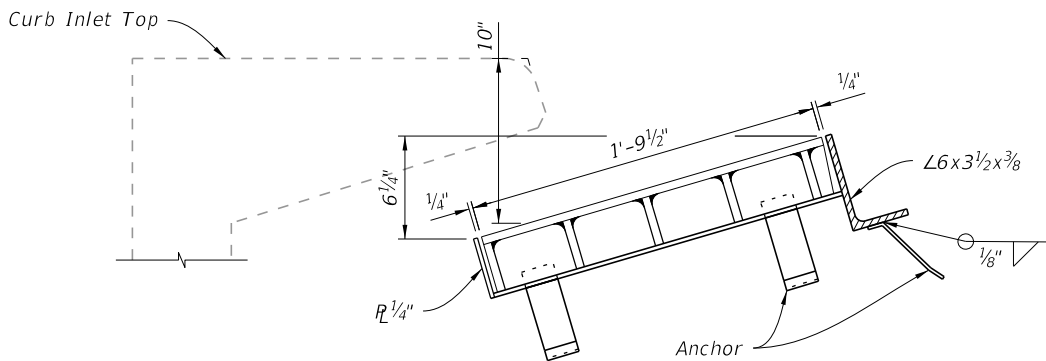

SECTION I-I

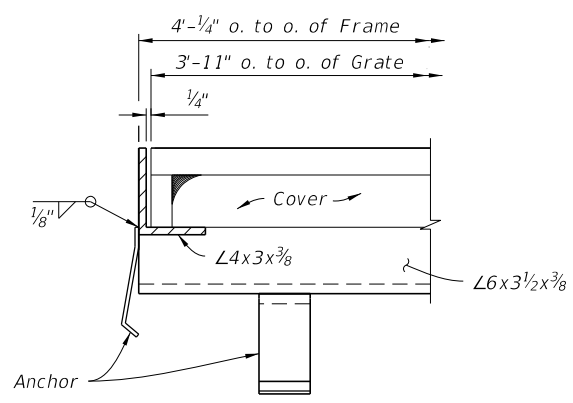

SECTION J-J

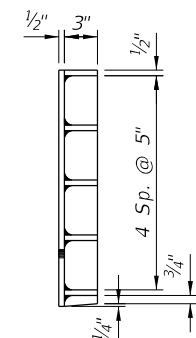

SECTION O-O

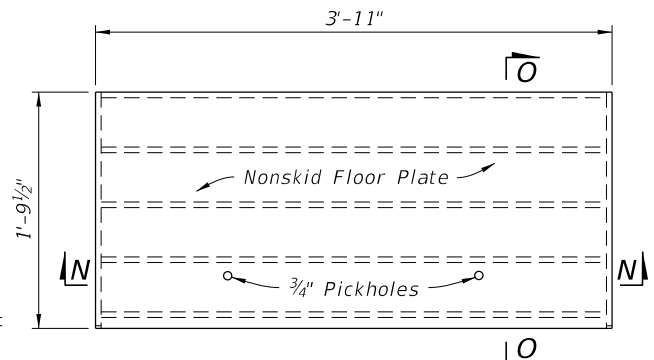

TOP

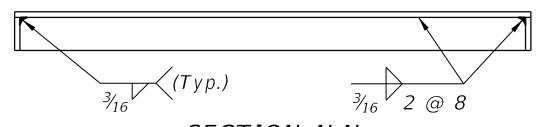

SECTION N-N

STEEL GRATE

GRATE, ANCHOR, AND GROUTING DETAILS

9/28/2023 1:51:37 PM

LAST REVISION 11/01/20	REVISION	DESCRIPTION:		FY 2024-25 STANDARD PLANS	CURB INLET TOP TYPES 5 AND 6	INDEX 425-021	SHEET 7 of 7
---------------------------	----------	--------------	--	------------------------------	------------------------------	------------------	-----------------