

TYPE I

TO BE USED WHERE BRIDGE OPERATORS ARE FULL TIME OR A DAILY BASIS.

* Field conditions may require adjustment of this standard distance.

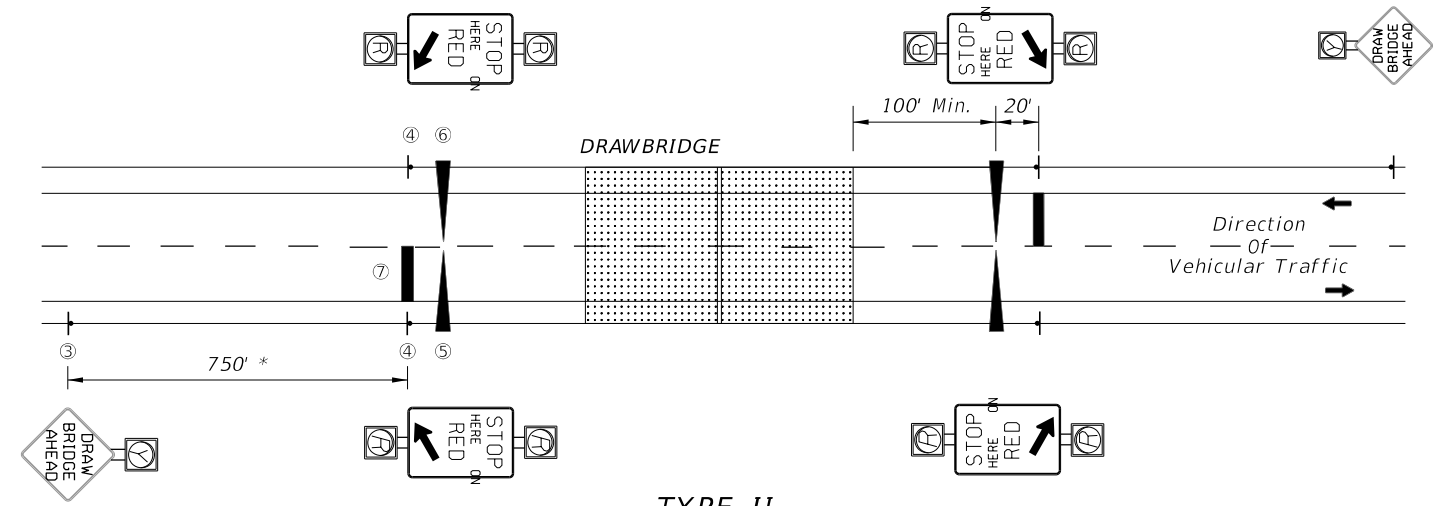

TYPE II

TO BE USED WHERE TYPE I IS NOT APPLICABLE (USUALLY WHEN THE BRIDGE OPERATOR IS "ON CALL").

TYPICAL BRIDGE MOUNTS

NOTES:

1. A bypass switch shall be installed to override each timing interval in case of a malfunction.
2. "STOP HERE ON RED" is omitted in Type I operation and "TRAFFIC SIGNALS" are omitted in Type II operation.
3. The time between beginning of flashing yellow on "Drawbridge Ahead" sign and the clearance of traffic signal to red, or beginning of flashing red should not be less than the travel time of a passenger car, from the sign location to the stop line, traveling at the 85 percentile approach speed.
4. Beginning of operation of drawbridge gates shall not be less than 15 seconds after steady red or 20 seconds after flashing red (Actual time may be determined by the bridge tender.)
5. Time of gate lowering and raising is dependent upon gate type.
6. Time of bridge opening is determined by the bridge tender.
7. Each gate shall be operated by a separate switch.
8. On each approach (Type II), all four red signals shall be on the same two circuit flashers, with the two top signals on one circuit, and the two bottom signals on the alternately flashing circuit.
9. A Drawbridge Ahead sign is required for both types of signal operation, However a flashing beacon shall be added to the sign when physical conditions prevent a driver traveling at the 85% approach speed from having continuous view of at least one signal indication for approximately 10 seconds.
10. Requirements on gate installation are contained in the "Manual on Uniform Traffic Control Devices" Section 4J.
11. "In accordance with Traffic Engineering Manual (Topic Number 750-000-005) Section 2.1, SLIPPERY WHEN WET SIGNS shall be placed in advance of all MOVABLE and NONMOVABLE STEEL DECK BRIDGES."



W8-5
SLIPPERY WHEN WET SIGN
See Note 11

LEGEND:

- ① TRAFFIC SIGNALS } Mast Arm Mounted (Off Bridge)
- ② DRAWBRIDGE SIGN } Monotube Support Mounted (On Bridge)
- ③ DRAWBRIDGE AHEAD SIGN WITH YELLOW FLASHING BEACON } Ground Mounted
- ④ STOP HERE ON RED SIGN WITH RED FLASHING BEACONS }
- ⑤ ENTRANCE GATE
- ⑥ EXIT GATE
- ⑦ 24" THERMOPLASTIC STOP BAR

SIGNALS & SIGNS	SIGNAL SWITCH	OFF				ON				OFF			
		BLANK				FLASHING YELLOW				BLANK			
SIGNALS & SIGNS	FLASHING BEACON DRAWBRIDGE AHEAD SIGN (See Note 9)	BLANK				FLASHING YELLOW				BLANK			
	STOP HERE ON RED (Type II only)	BLANK				FLASHING RED				BLANK			
SIGNALS & SIGNS	TRAFFIC SIGNALS (Type I only)	GREEN				YELLOW				RED			
	ENTRANCE GATES	RAISED				LOWERED				RAISED			
GATES	EXIT GATES	RAISED				LOWERED				RAISED			
	TIMING	Variable Time (See Note 3)	5 Sec. Min.	15 Sec. Min.	Variable Time (See Note 5)	Variable Time Bridge Open (See Note 6)	Variable Time (See Note 5)	Normal Operation					

SEQUENCE CHART

10/20/2022 8:49:37 AM

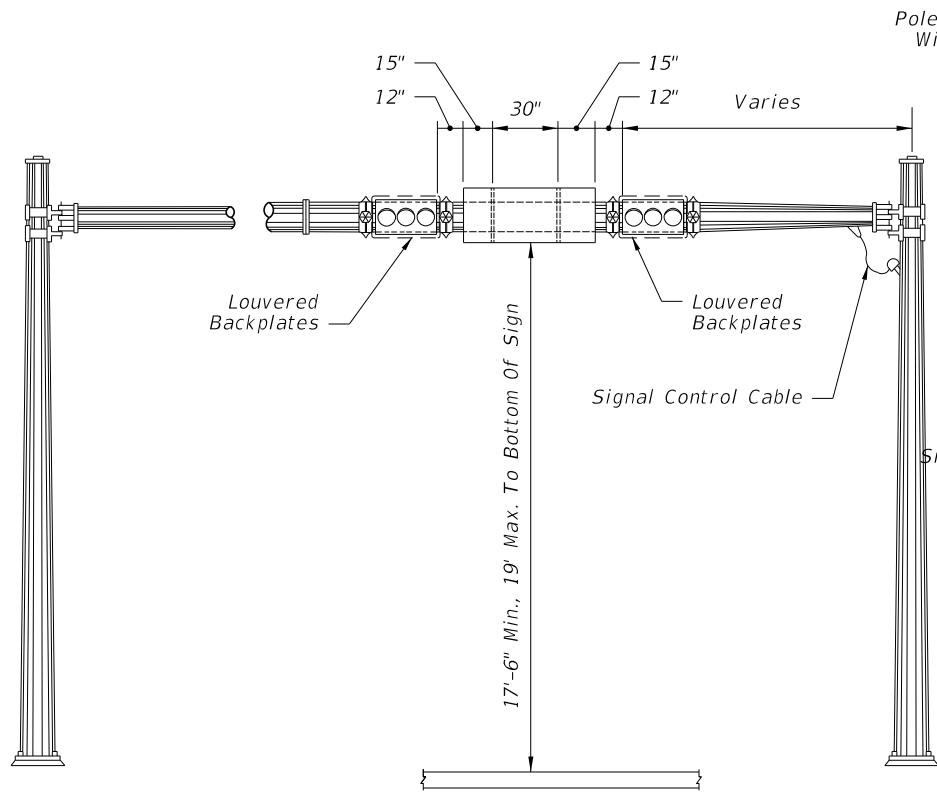

FIGURE - A
MONOTUBE SUPPORT MOUNTING

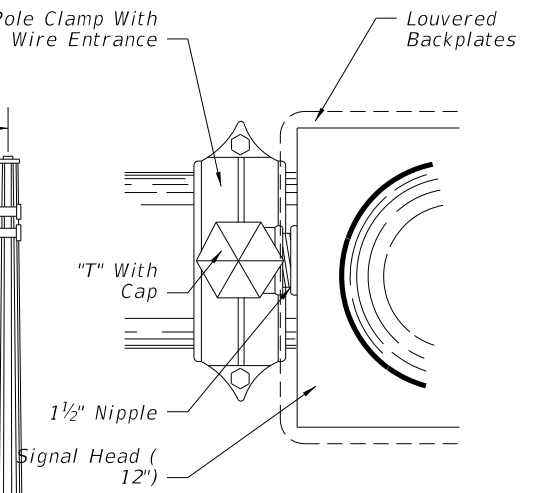

FIGURE - C

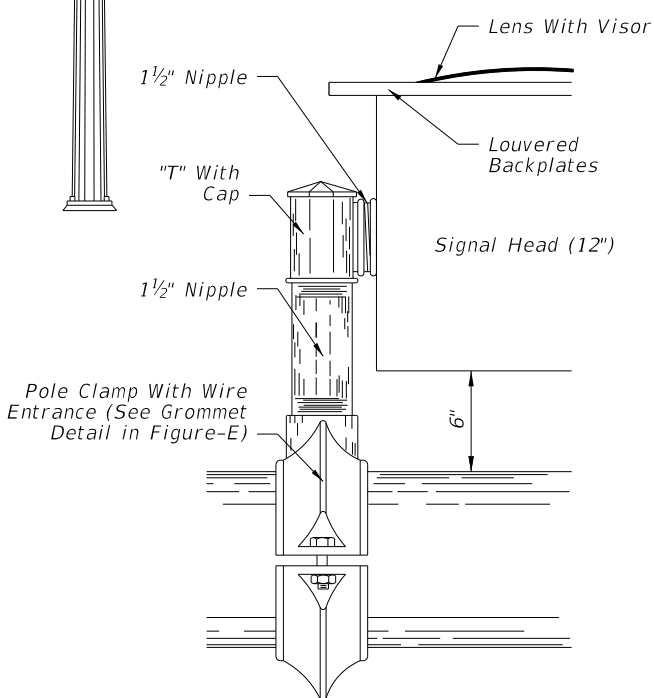

FIGURE - D

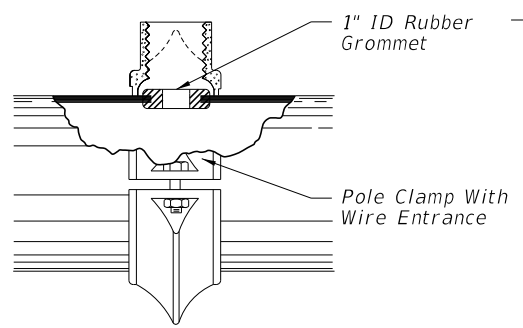

FIGURE - E

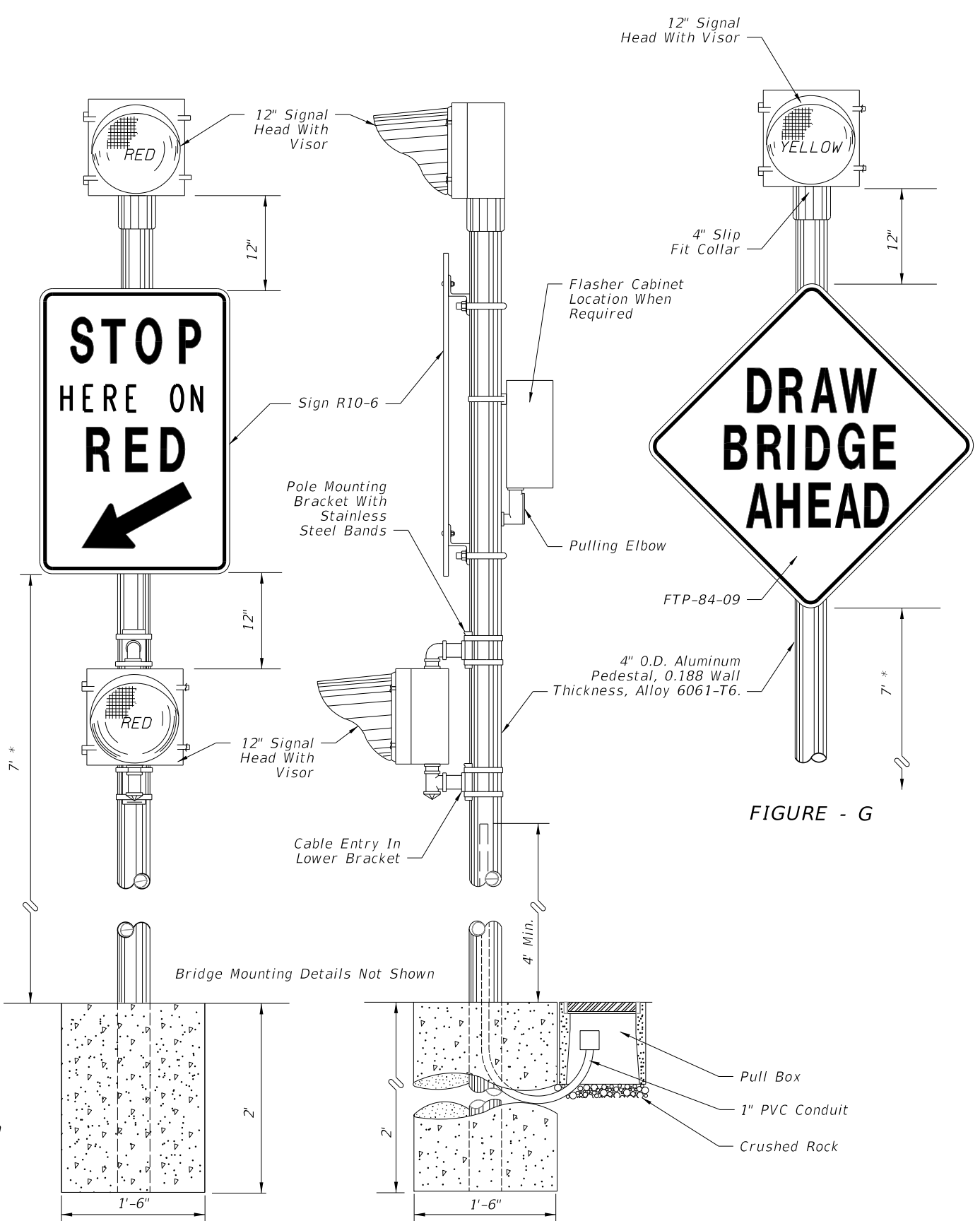

FIGURE - G

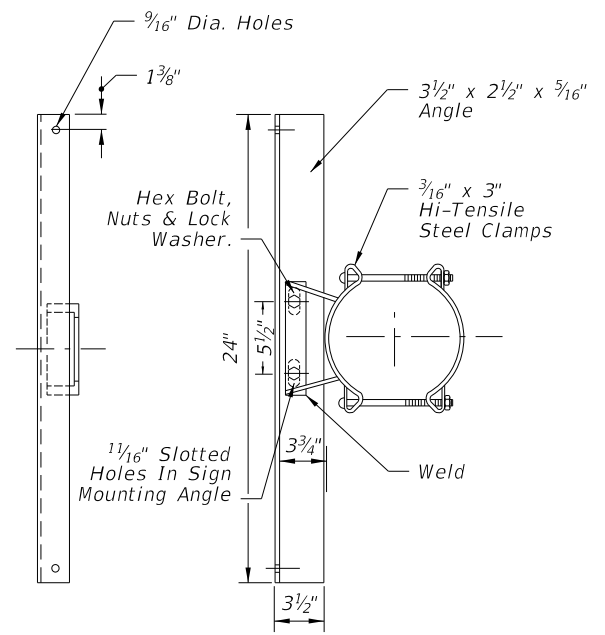



FIGURE - B

SIGN PANEL MOUNTING ASSEMBLY

SIGNAL HEAD MOUNTING ASSEMBLY

* Measured from the bottom of the sign to the near edge of the pavement. Horizontal distance between edge of the pavement and inside edge of sign will vary with condition at job site.

10/20/2022 8:49:36 AM

LAST REVISION 11/01/17	REVISION	DESCRIPTION:		FY 2023-24 STANDARD PLANS	TRAFFIC CONTROL DEVICES FOR MOVABLE SPAN BRIDGE SIGNALS	INDEX 508-T01	SHEET 2 of 3
---------------------------	----------	--------------	--	------------------------------	--	------------------	-----------------

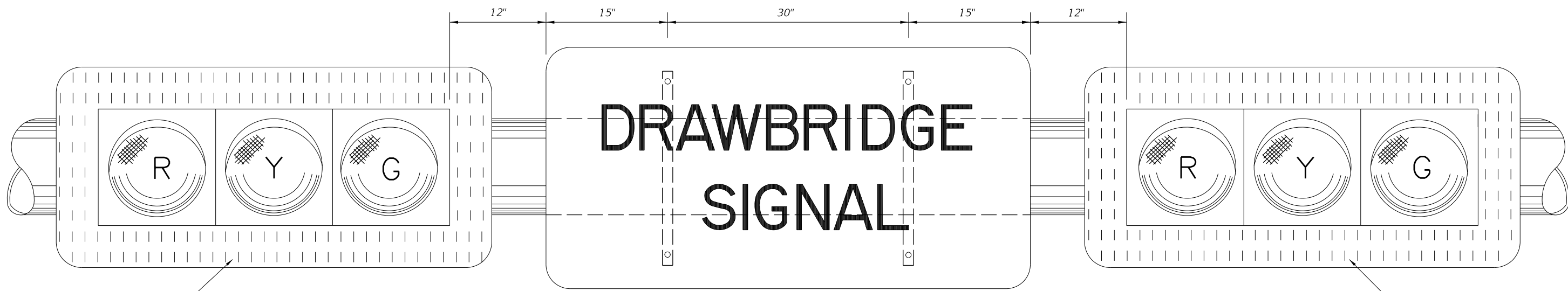

Louvered Backplates

5' x 2'-6"
2" Border-4" Radius
6" Series "D" Letters

Louvered Backplates

BLACK OPAQUE LEGEND AND BORDER ON REFLECTORIZED YELLOW BACKGROUND
TO BE USED WITH TYPE I OPERATION, AS SHOWN ON PREVIOUS SHEET
MONOTUBE SUPPORT MOUNTING

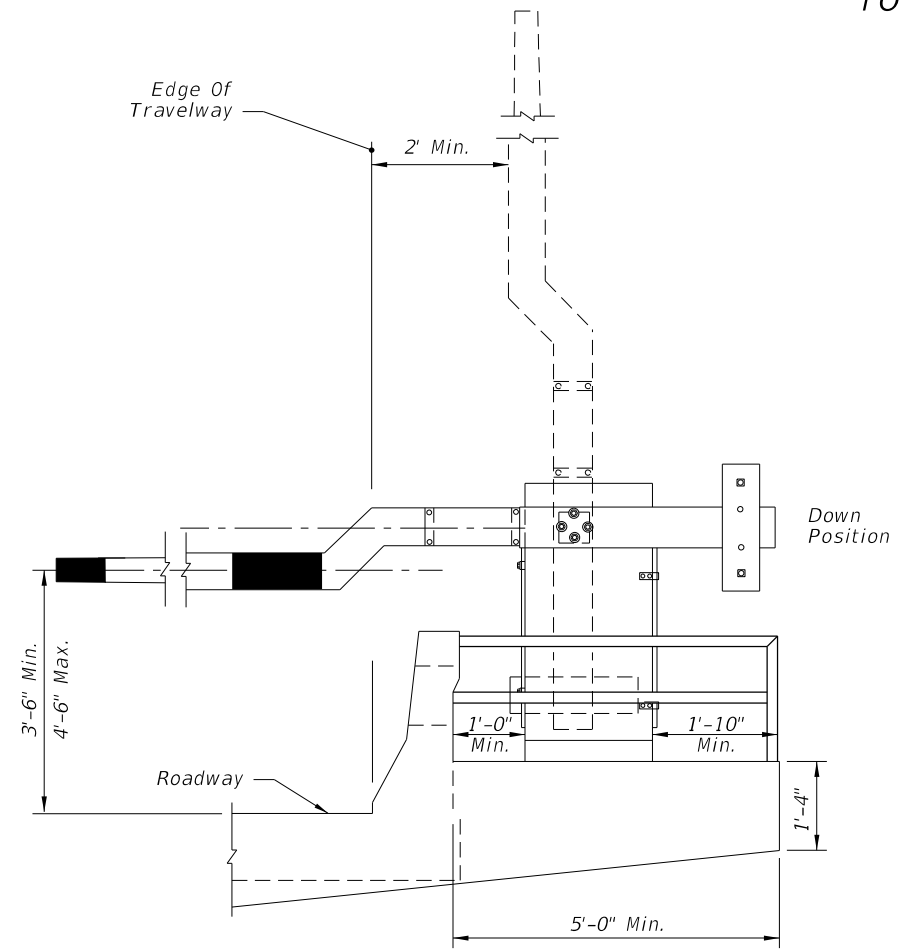

GATE & ARM DETAIL

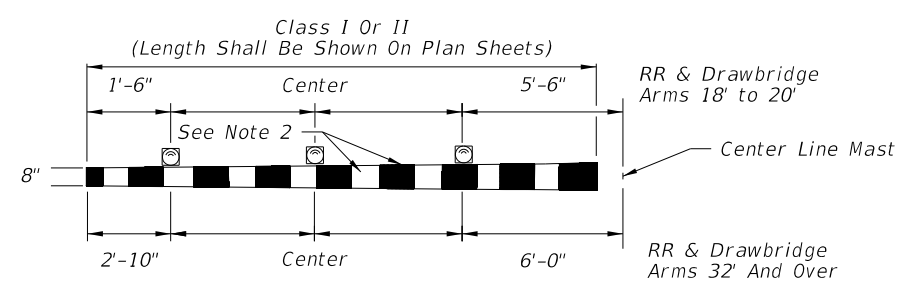
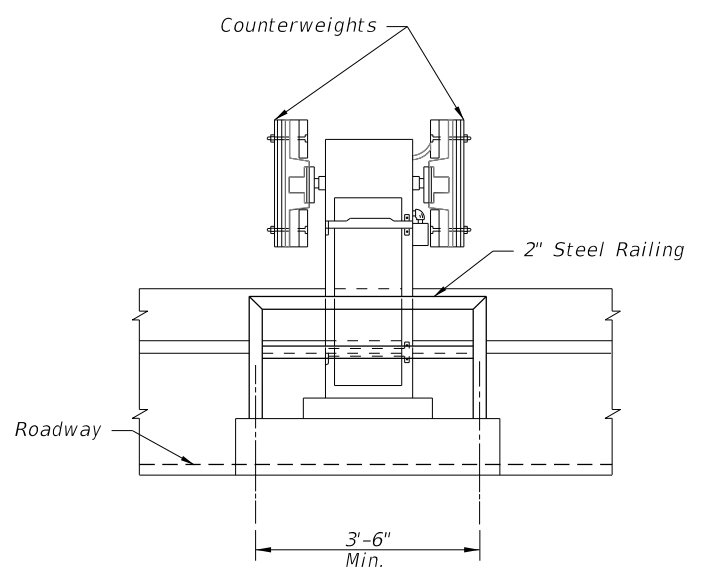

NOTES:

- 12 volt flashing red lights shall be mounted on gate arm and shall operate in the flashing mode only when gate arm is in the lower position or in the process of being lowered. The number of lights shall vary accordingly to length of the gate arm.
- Alternating 16" pattern of fully reflectorized red and white stripes.

TYPICAL LAMP PLACEMENT

10/20/2022 8:49:39 AM

LAST REVISION 11/01/17	REVISION	DESCRIPTION:		FY 2023-24 STANDARD PLANS	TRAFFIC CONTROL DEVICES FOR MOVABLE SPAN BRIDGE SIGNALS	INDEX 508-T01	SHEET 3 of 3
---------------------------	----------	--------------	--	------------------------------	--	------------------	-----------------

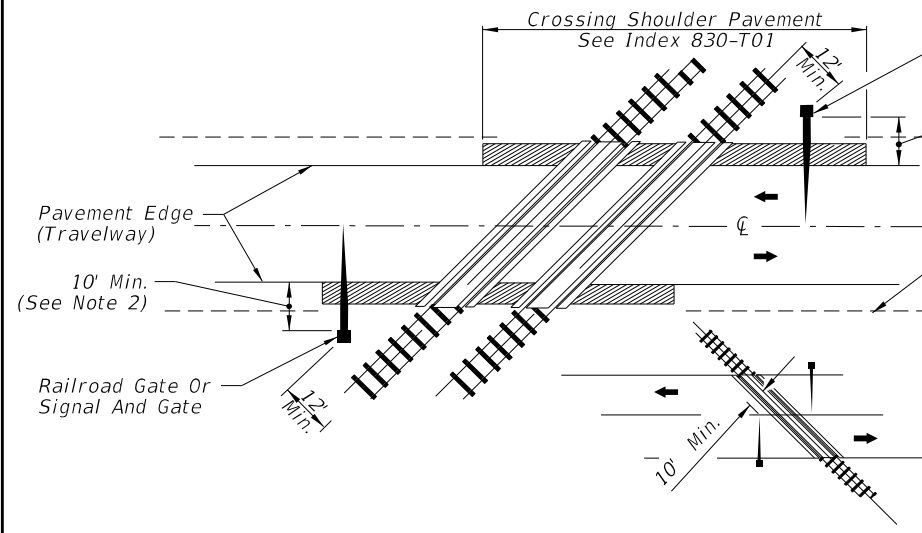

**SIGNAL PLACEMENT AT RAILROAD CROSSING
(2 - LANE DESIGN)**

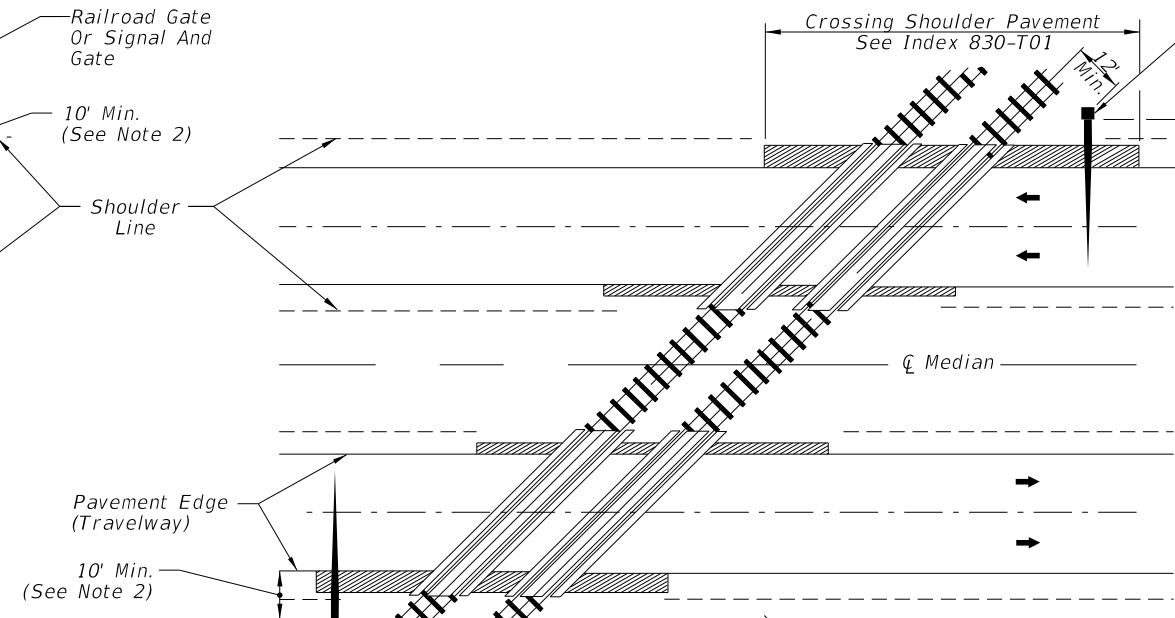

**SIGNAL PLACEMENT AT RAILROAD CROSSING
(4 - LANE DESIGN)**

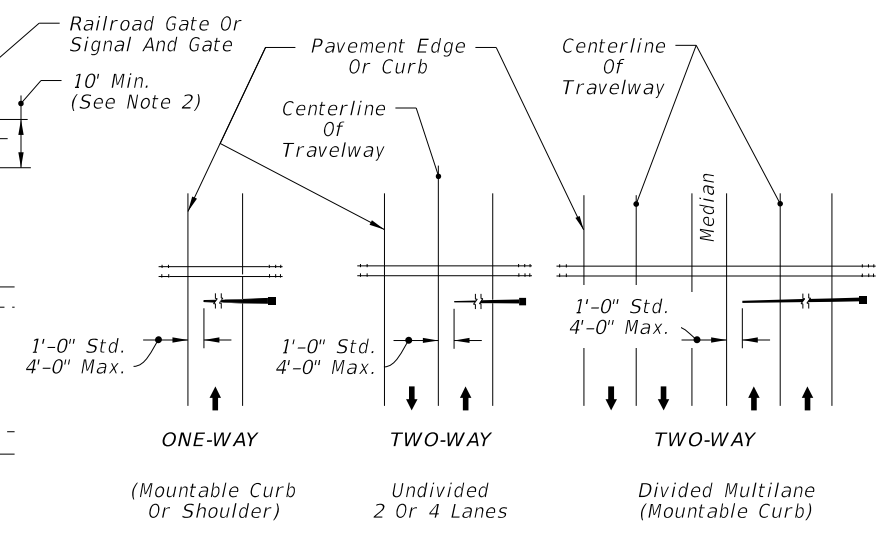

FIGURE 1

NOTE: Arrows denote direction of travel not pavement markings.

GENERAL NOTES:

1. No guardrail is proposed for signals; however, some form of impact attenuation device may be specified for certain locations.
2. Advance flasher to be installed when and if called for in Plans or Specifications.
3. Top of foundation shall be no higher than 4" above finished shoulder grade.
4. Type of traffic control device
 - I Flashing warning devices
 - II Flashing warning devices with cantilever
 - III Flashing warning devices with gate
 - IV Flashing warning devices with cantilever and gate
 - V Gate
5. Class of traffic control devices (Not Shown)
 - I 2 Quadrant flashing warning devices-one track
 - II 2 Quadrant flashing warning devices-multiple tracks
 - III 2 Quadrant flashing warning devices and gates-one track
 - IV 2 Quadrant flashing warning devices and gates-multiple tracks
 - V 3-4 Quadrant flashing warning devices and gates-one track
 - VI 2-4 Quadrant flashing warning devices and gates-multiple tracks

NOTE:

1. Two separate foundations may be required (one for signals, one for gate), depending on type of equipment used.
2. When 10' is deemed impractical the control device can be located as close as 2' from the edge of a paved shoulder but not less than 6' from the edge of the near traffic lane.

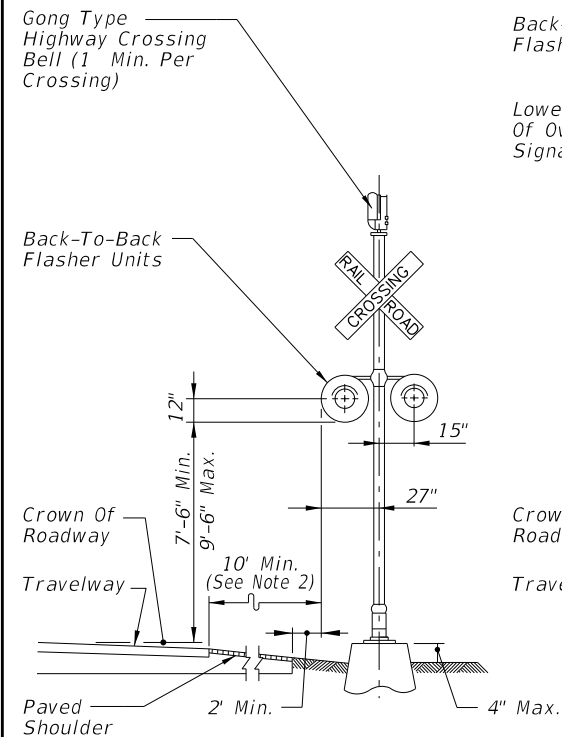

TYPE I

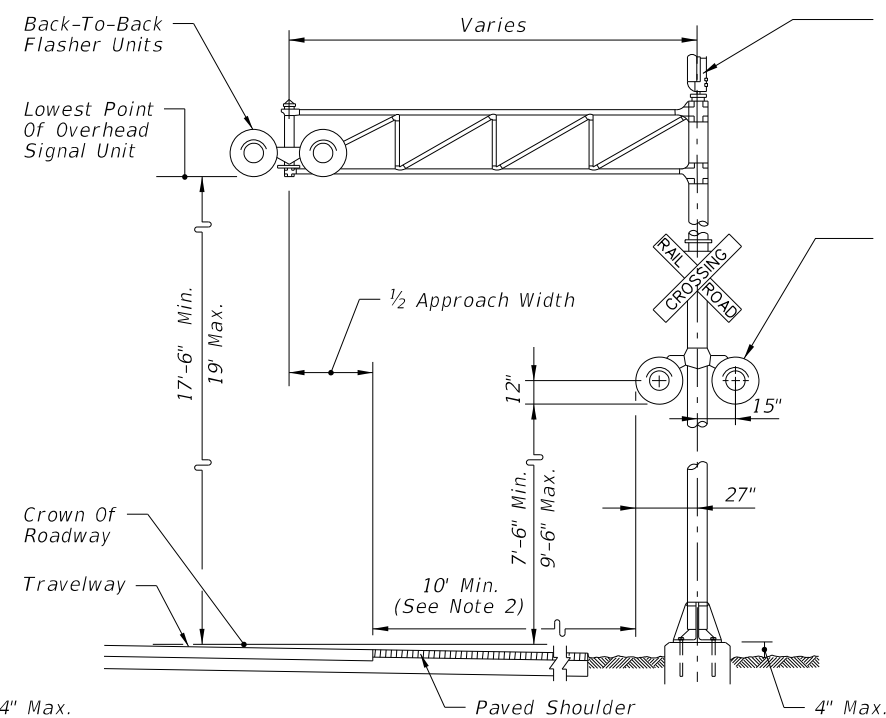

TYPE II

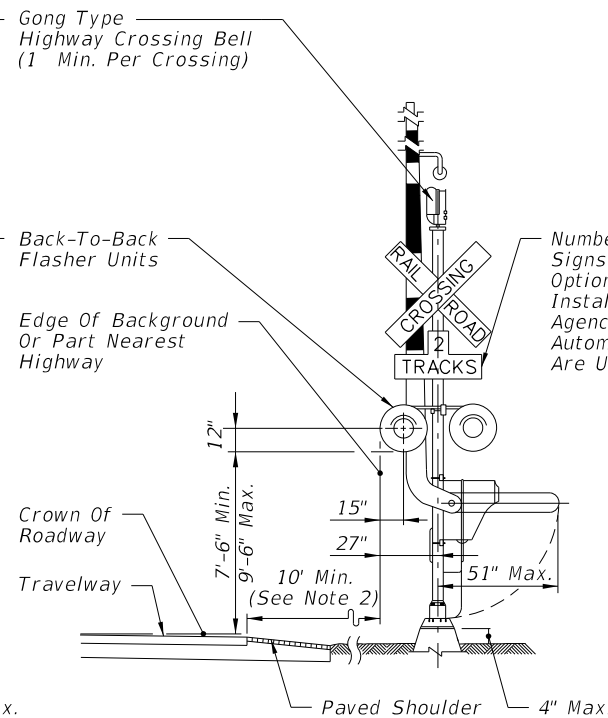

TYPE III AND TYPE V

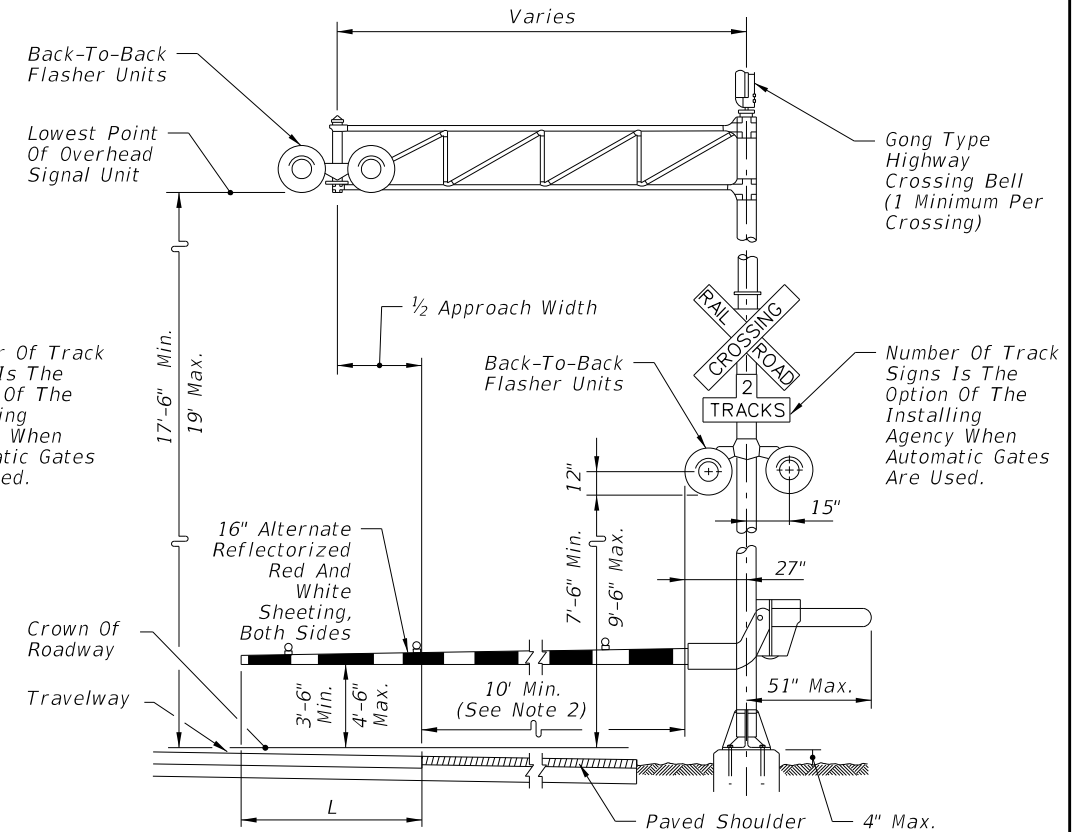

TYPE IV AND TYPE VI

TRAFFIC CONTROL DEVICES FOR FLUSH SHOULDER ROADWAY

10/20/2022 8:49:40 AM

LAST REVISION 02/05/21	REVISION	DESCRIPTION:		FY 2023-24 STANDARD PLANS	RAILROAD GRADE CROSSING TRAFFIC CONTROL DEVICES	INDEX 509-070	SHEET 1 of 3
---------------------------	----------	--------------	--	------------------------------	--	------------------	-----------------

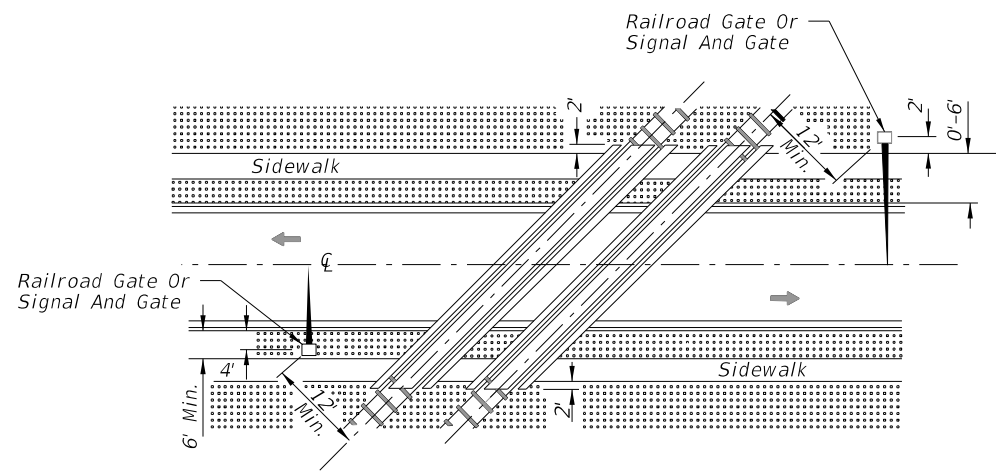

ACUTE ANGLE (AND RIGHT ANGLE)

SIGNAL PLACEMENT AT RAILROAD CROSSING

(2 LANES, CURB & GUTTER)

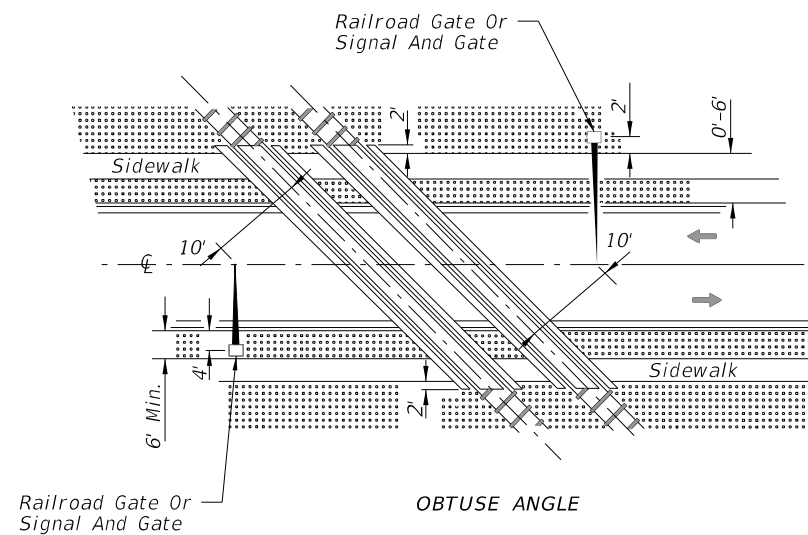

OBTUSE ANGLE

SIGNAL PLACEMENT AT RAILROAD CROSSING

(2 LANES, CURB & GUTTER)

NOTES:

1. The location of flashing warning devices and stop lines shall be established based on future (or present) installation of gate with appropriate track clearances.
2. Where plans call for railroad traffic control devices to be installed in curbed medians, the minimum median width shall be 12'-6".
3. Location of railroad traffic control device is based on the distance available between face of curb & sidewalk. 0' to 6' - Locate device outside sidewalk. Over 6' - Locate device between face of curb and sidewalk.
4. Stop line to be perpendicular to edge of roadway, approx. 15' from nearest rail; or 8' from and parallel to gate when present.
5. When a cantilevered-arm flashing warning device is used, the minimum vertical clearance shall be 17'-6" from above the Crown of Roadway to the Lowest Point of the Overhead Signal Unit.

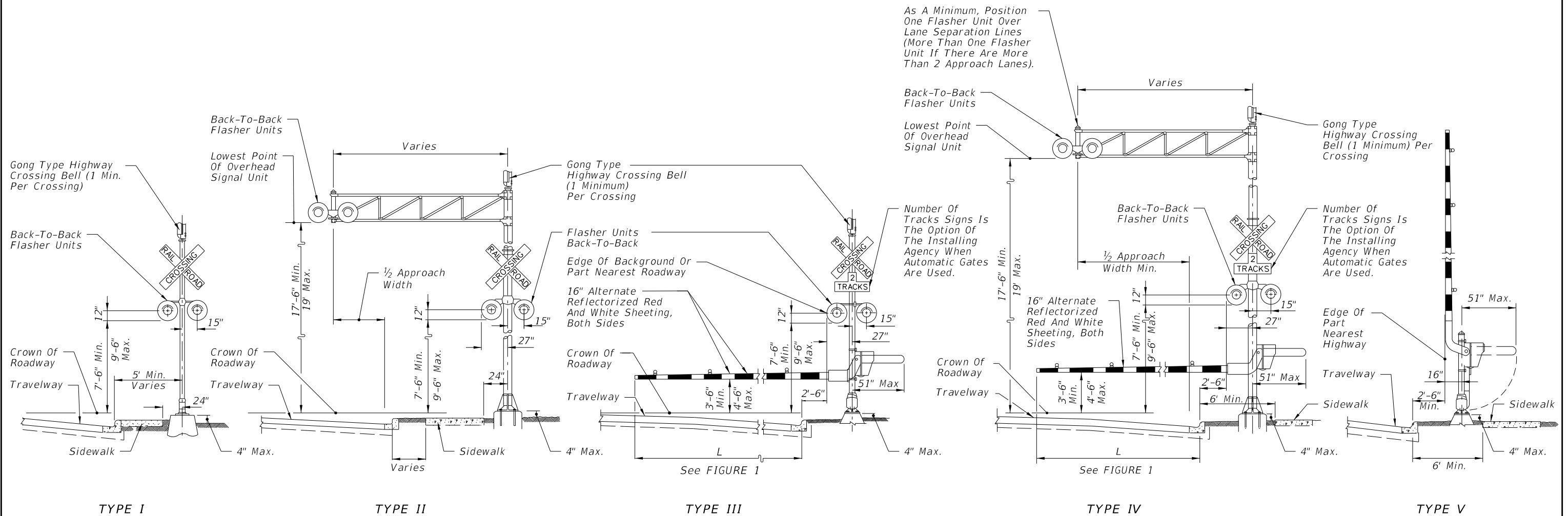

TYPE I

TYPE II

TYPE III

TYPE IV

TYPE V

TRAFFIC CONTROL DEVICES FOR CURBED ROADWAY

10/20/2022 8:50:08 AM

LAST REVISION 02/05/21	DESCRIPTION:		FY 2023-24 STANDARD PLANS	RAILROAD GRADE CROSSING TRAFFIC CONTROL DEVICES	INDEX 509-070	SHEET 2 of 3

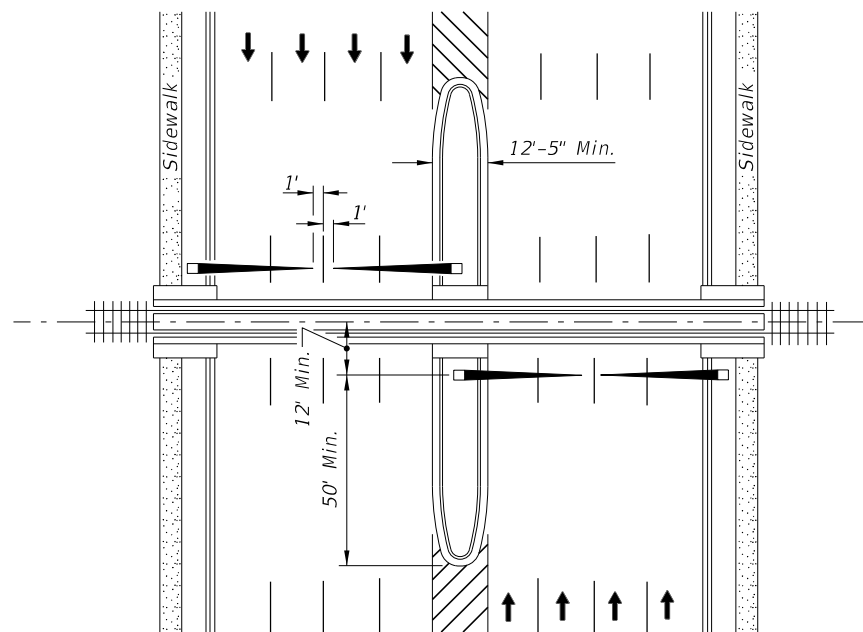

PLAN

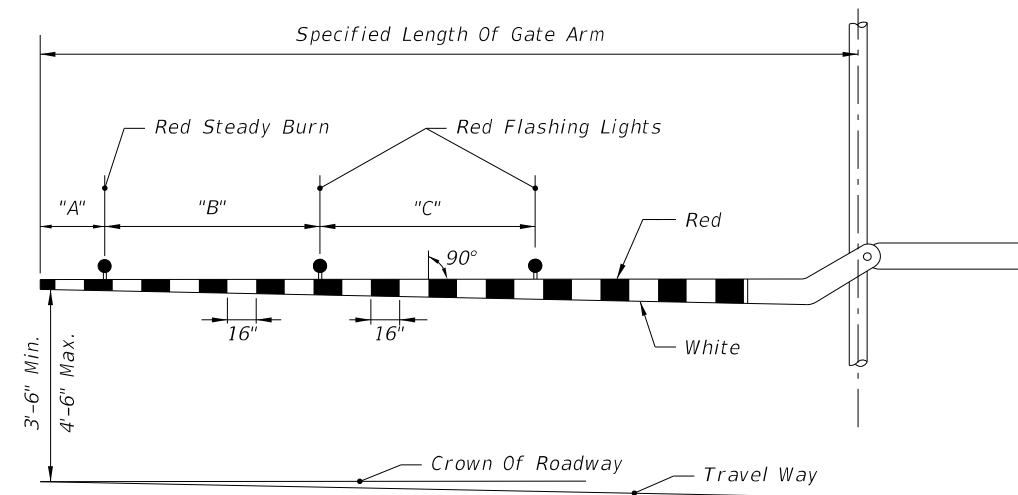

GATE ARM DETAIL

RAILROAD GATE ARM LIGHT SPACING			
Specified Length Of Gate Arm	Dimension "A"	Dimension "B"	Dimension "C"
14 Ft.	6"	36"	5'
15 Ft.	18"	36"	5'
16-17 Ft.	24"	36"	5'
18-19 Ft.	28"	41"	5'
20-23 Ft.	28"	4'	5'
24-28 Ft.	28"	5'	5'
29-31 Ft.	36"	6'	6'
32-34 Ft.	36"	7'	7'
35-37 Ft.	36"	9'	9'
38 And Over	36"	10'	10'

NOTE:

For additional information see the "Manual On Uniform Traffic Control Devices", Part 8; The "Traffic Control Handbook", Part VIII; and AASHTO "A Policy On Geometric Design Of Streets And Highways".

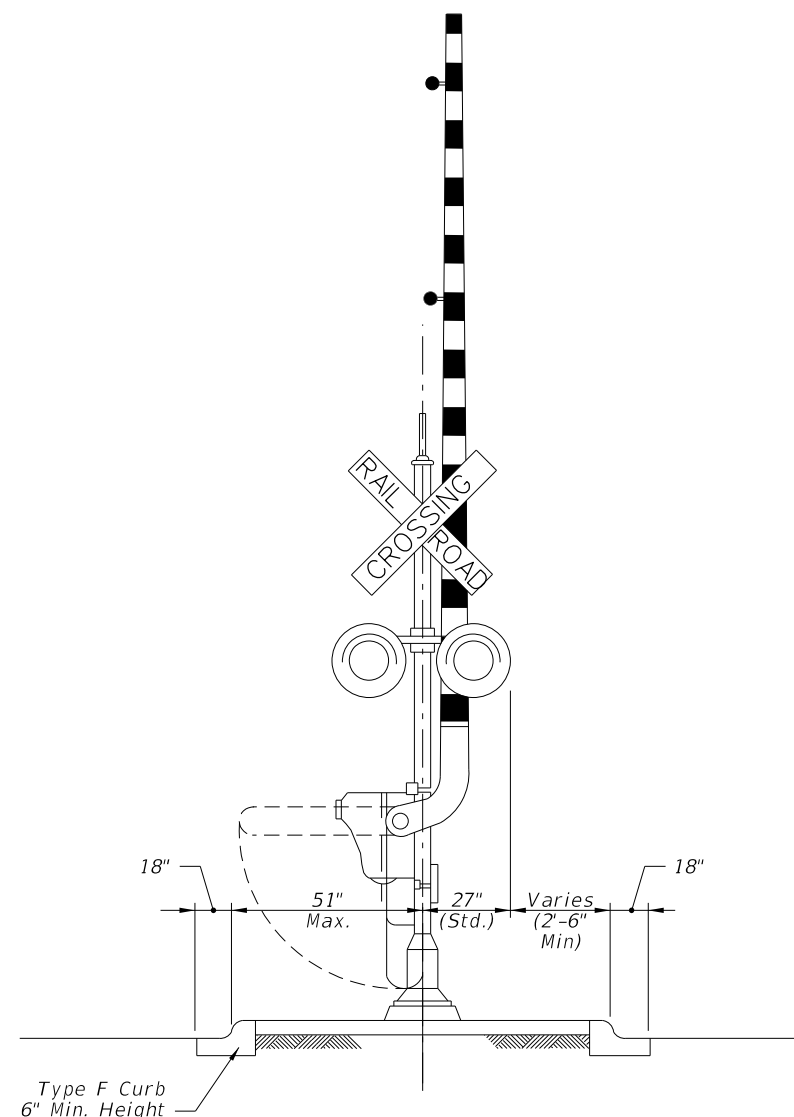

MEDIAN SECTION AT SIGNAL GATES

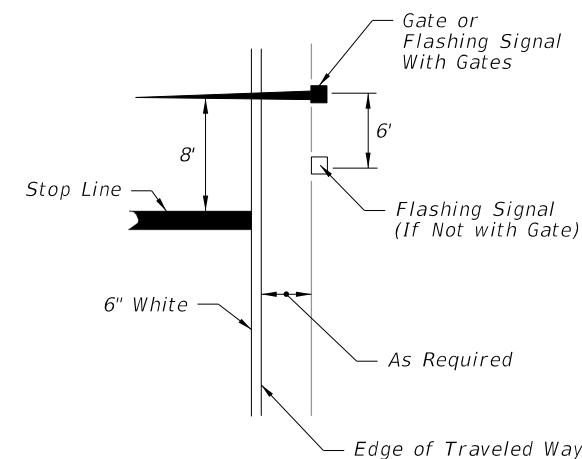

RELATIVE LOCATION OF CROSSING TRAFFIC CONTROL DEVICES

MEDIAN SIGNAL GATES FOR MULTILANE UNDIVIDED URBAN SECTIONS
(Three or More Driving Lanes in one Direction, 45 mph or less)

10/20/2022 8:50:09 AM

LAST REVISION 02/05/21	DESCRIPTION:
---------------------------	--------------



FY 2023-24
STANDARD PLANS

RAILROAD GRADE CROSSING
TRAFFIC CONTROL DEVICES

INDEX
509-070

SHEET
3 of 3

The Distance Is Measured Along Right Edge Of Pavement From RR Stop Bar To Sign Advance Warning Sign.

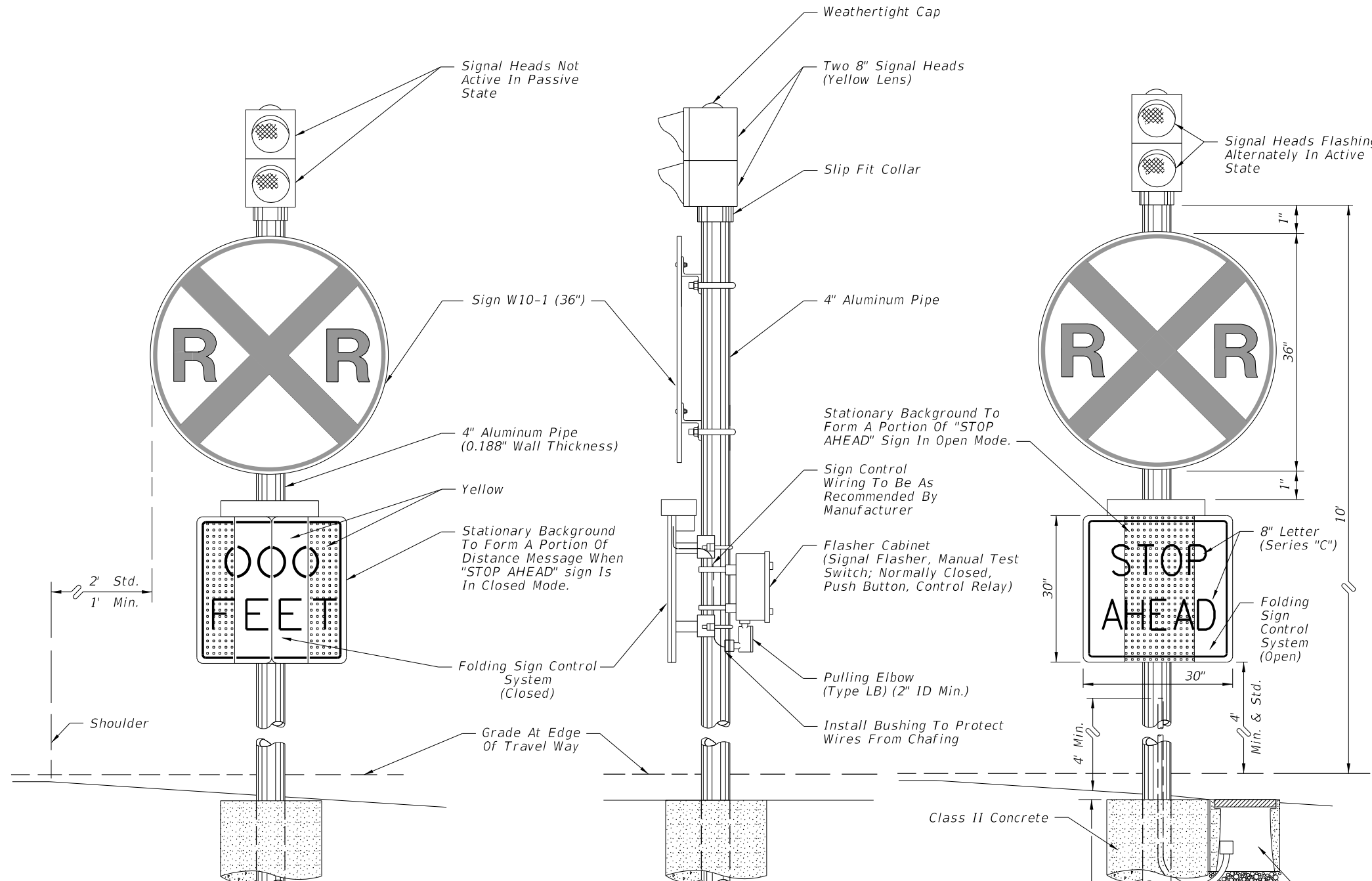

LOCATION OF THE ADVANCE WARNING SIGN

SPEED (mph)	DISTANCE (ft)
Min.	50
30	100
35	100
40	125
45	175
50	250
55	325
60	400

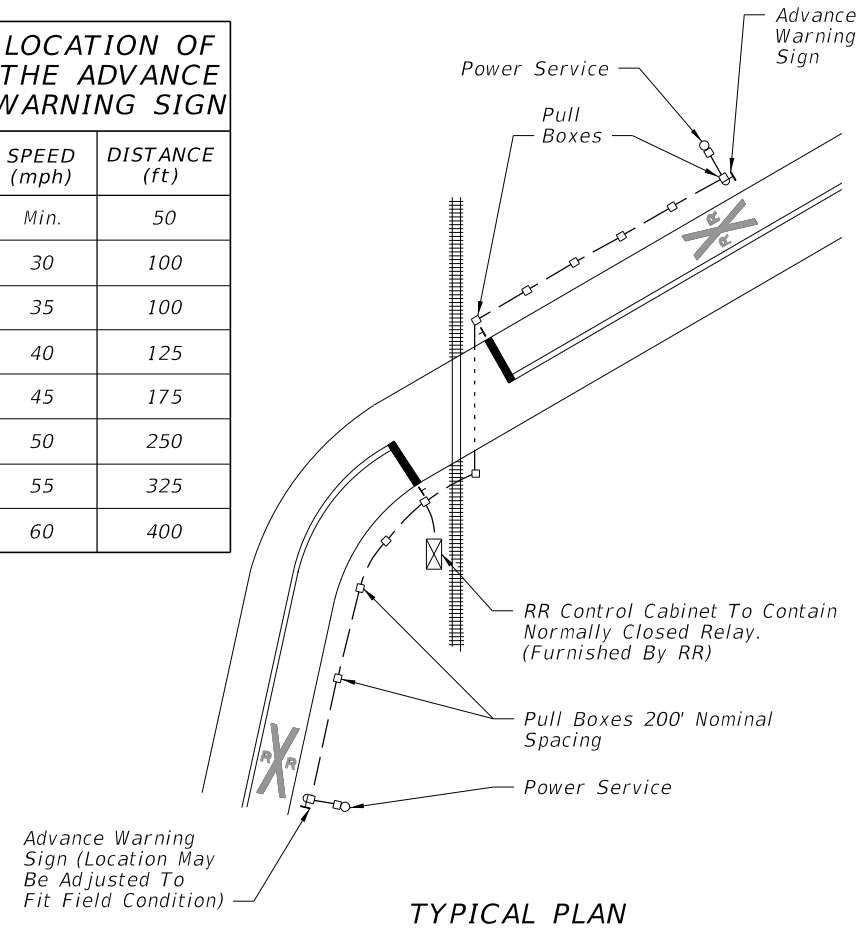

FRONT VIEW

SIDE VIEW

FRONT VIEW

PASSIVE STATE
(TRAIN CIRCUIT NOT ACTUATED)

ACTIVE STATE
(TRAIN CIRCUIT ACTUATED)

NOTE:
1. "STOP AHEAD" is standard and preferred sign message.
Another message may be approved when appropriate for specific situations.

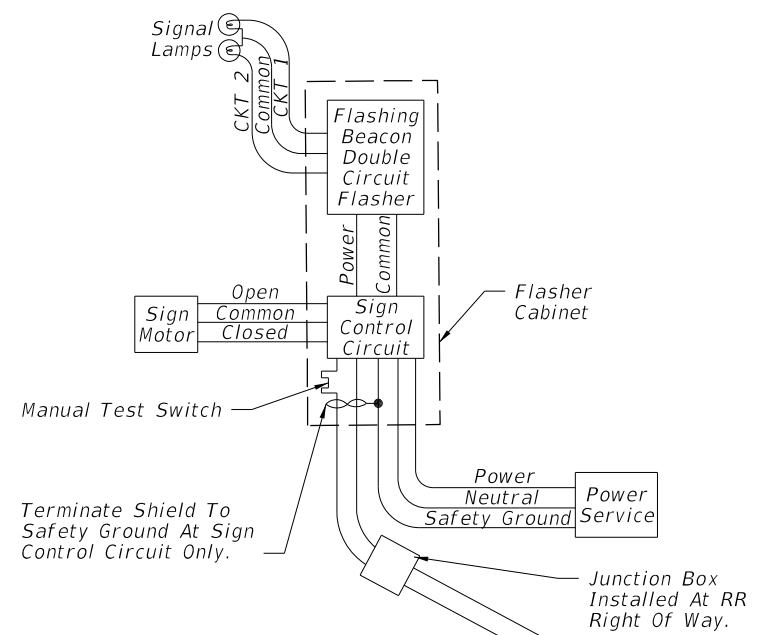

NOTE:
Conduit and cable from the normally closed relay of RR controller cabinet to the junction box shall be furnish & installed by RR.

FUNCTIONAL BLOCK DIAGRAM

10/20/2022 8:50:10 AM

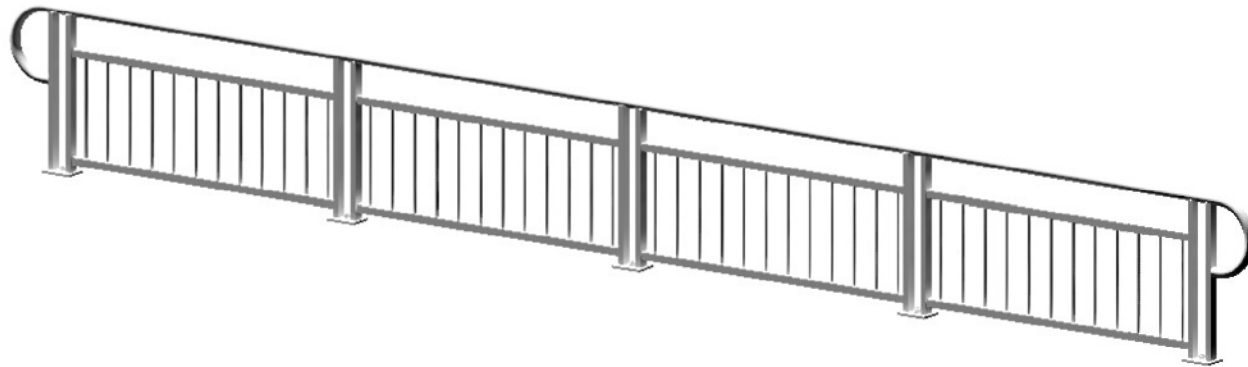

3D VIEW OF RAILING WITH TYPE 1 - PICKET INFILL PANEL
(42" Height shown, 48" Height Similar)

TABLE 1 - RAILING MEMBERS

MEMBER	DESIGNATION	OUTSIDE DIMENSION	WALL THICKNESS
Post "A"	HSS 2½ x 1½ x 1/8	2.50" x 1.50"	0.125"
Post "B"	HSS 2½ x 1½ x 3/16	2.50" x 1.50"	0.188"
Top Rail	2½" NPS (Sch. 10)	2.875"	0.120"
	HSS 3.000 x 0.120	3.000"	0.120"
End Hoops	2½" NPS (Sch. 10)	2.875"	0.120"
	HSS 3.000 x 0.120	3.000"	0.120"
Top Rail Joint/Splice Sleeves	HSS 2.500 x 0.125	2.500"	0.125"
Intermediate & Bottom Rail	HSS 2 x 2 x 3/16	2.00" x 2.00"	0.188" (1)
Int. & Bottom Rail Post Connection Sleeve	HSS 1.500 x 0.125	1.500"	0.125" (1)
Handrail Joint/Splice Sleeves	1" NPS (Sch. 40)	1.315"	0.133"
	HSS 1.500 x 0.125	1.500"	0.125"
Handrails	1½" NPS (Sch. 40)	1.900"	0.145"
Handrail Support Bar	¾" Ø Round Bar	0.750"	N/A
Pickets (Type 1 Infill Panel)	¾" Ø Round Bar	0.750"	N/A
Infill Panel Members (Types 2 - 5)	Varies (See Details)	Varies	Varies

TABLE 1 NOTES:

(1) 0.125" wall thickness permitted for rails with post spacings less than 5'-8", except that Post Connection Sleeve must be 1¼" NPS (Sch. 40).

NOTES

Notes:

- Shop Drawings are required; see Specification Section 515
- For bridge mounted railings work this Index with Index 515-051 Bridge Bicycle/Pedestrian Railing
- Materials:
 - Pipe Rails and Pickets: ASTM A500 Grade B, C or D, or ASTM A53 Grade B for standard weight pipe (Schedule 40) and ASTM A36 for bars.
 - Structural Tube: ASTM A500 Grade A, B, C, or D or ASTM A501
 - Steel Plate: ASTM A36 or ASTM A709 Grade 36
 - U-Channels and filler plates: ASTM A36 or ASTM A1011 (Grade 36).
 - Stainless steel (SS) screws: Type 316 or 18-8 Alloy
 - Galvanized Steel Fasteners: coated in accordance with Specification Section 962.
 - Hex Head Bolts: ASTM A 307
 - 7/8" diameter single bolt option, Grade 36
 - 7/16" four bolt option, Grade 55
 - Adhesive Anchors: ASTM F1554 fully threaded rods, Grade 55
 - Hex Nuts: ASTM A563
 - Flat Washers: ASTM F436
 - Plate Washers: ASTM A36 or ASTM A706 Grade 36.
 - Shims: ASTM B209 Alloy 6061
 - Bearing Pads: 1/8" Plain, Fabric Reinforced or Fabric Laminated pads that meet the requirements of Specification Section 932 for Ancillary Structures.
- Fabricate pickets and vertical panel elements parallel to the posts; except Type 2, 3 and 5 panel infills may be fabricated parallel to the longitudinal grade. Maintain a maximum clear opening of 5/8" for standard installations and 3/8" when a 4" sphere requirement is indicated in the Data Tables.
- Maximum spacing between expansion joints is 40'-0". Locate an Expansion Joint between the posts on either side of the Deck Expansion Joint.
- Field splices are similar to the Expansion Joint Detail and may be approved by the Engineer to facilitate handling; but the top rail must be continuous across a minimum of two posts.
- For intermediate and bottom horizontal rails, the screwed joints shown may be substituted with alternate joints shown in detail "K".
- Make corners and changes in tangential longitudinal alignment with a 9" bend radius or terminate adjoining sections with mitered end sections when handrails are not required.
- For changes in tangential longitudinal alignment greater than 45°, position posts a maximum of 2'-0" each side of the corner but not at the corner apex.
- For curved longitudinal alignments, shop bend the top and bottom rails and handrails to match the alignment radius.
- Handrails are required and must be continuous at landings for:
 - Grades Steeper than 5%.
 - Three or more steps
- Installation: Cutting of reinforcing steel is permitted for post installed anchors.

10/20/2022 8:50:11 AM

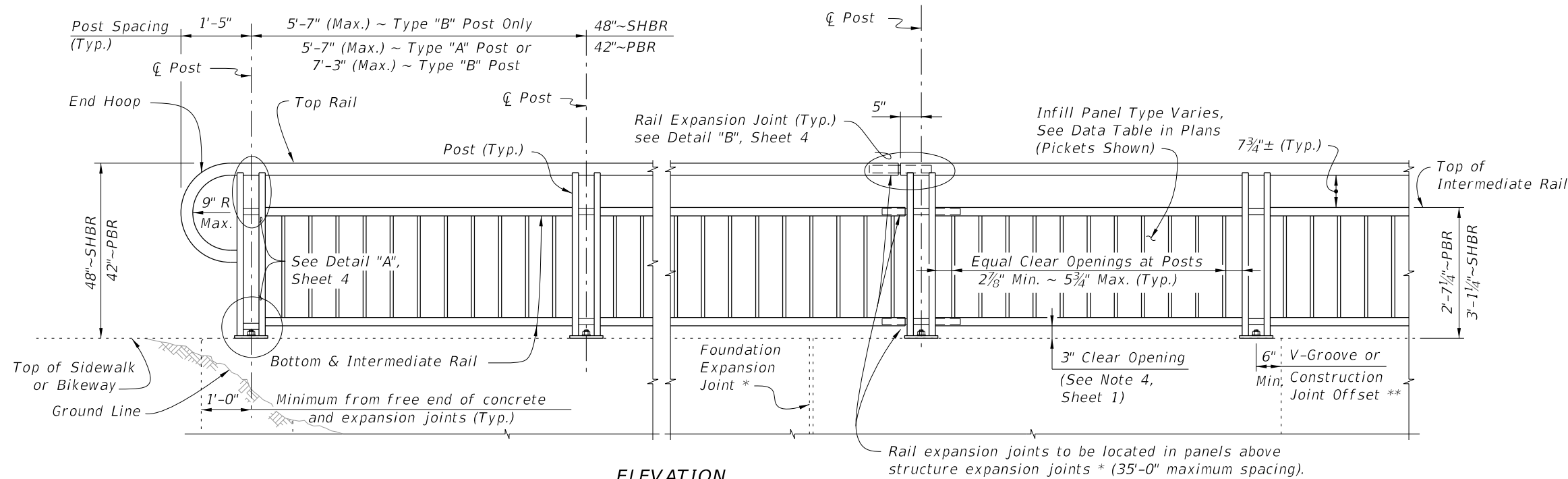

ELEVATION
(Showing Outside Face of Railing with Type "A" Posts)

TYPICAL RAILING DETAILS & RAILINGS ON GRADES 0% TO 5%
(Type 1 - Picket Railing Shown, Other Types Similar)

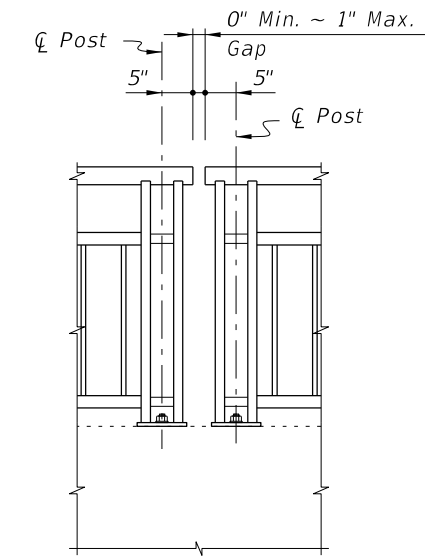

Note: Non-continuous corners are permitted when handrails are not required.

EXPANDED ELEVATION AT CORNERS
DETAIL FOR NON-CONTINUOUS RAILING AT CORNERS

- NOTES:**
 * Keyed construction joints in Index 400-011 Gravity Wall are not considered to be expansion joints.
 ** Contraction joints (Tooled or Saw Cut) in sidewalks do not require a 6" minimum offset.

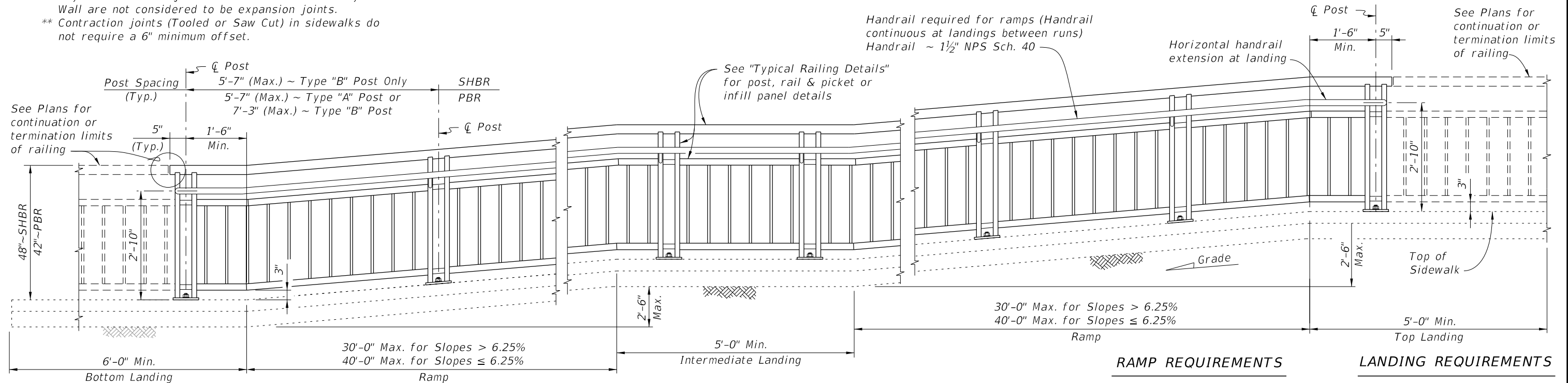

ELEVATION
(Showing Inside Face of Railing with Type "A" Posts)

RAILINGS ON GRADES STEEPER THAN 5%
(Type 1 - Picket Railing Shown, Other Types Similar)

RAMP REQUIREMENTS
 For slopes greater than 5%:
 Max. ramp slope = 8.33%
 Max. ramp cross-slope = 2.0%

LANDING REQUIREMENTS
 Max. landing slope = 2%
 Max. landing cross-slope = 2%

10/20/2022 8:50:13 AM

LAST REVISION 11/01/16	DESCRIPTION:		FY 2023-24 STANDARD PLANS	PEDESTRIAN/BICYCLE RAILING (STEEL)	INDEX 515-052	SHEET 2 of 8
---------------------------	--------------	--	-------------------------------------	---	-------------------------	------------------------

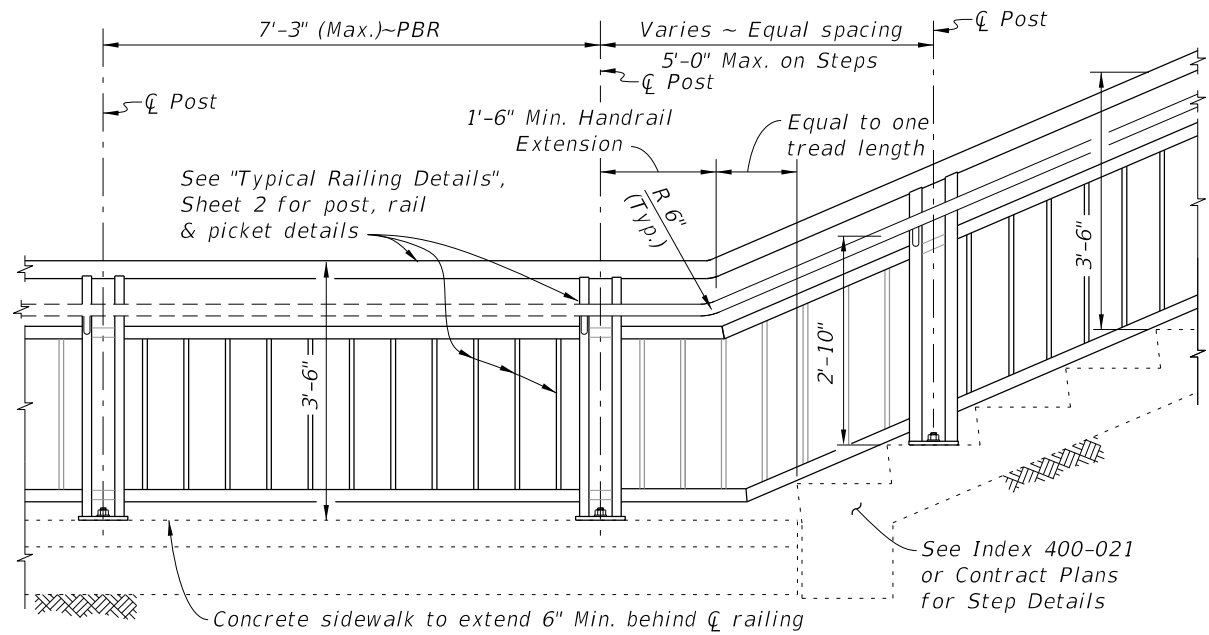

RAILING CONTINUATION BEYOND STEPS OR STAIRS
(Bottom shown, Top similar)

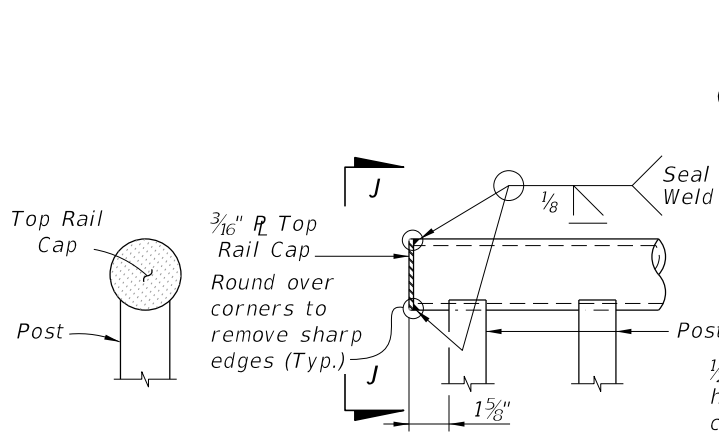

VIEW J-J DETAIL "J" - ELEVATION VIEW TOP RAIL TERMINATION

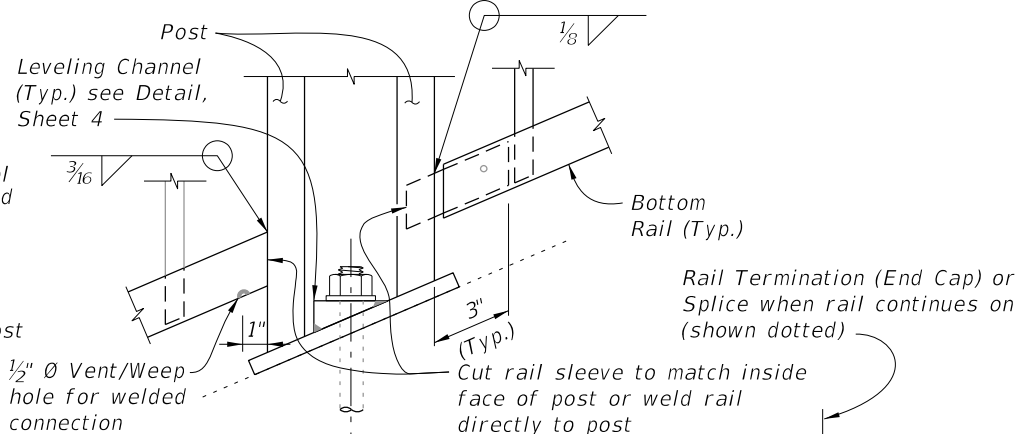

DETAIL "K" - ELEVATION VIEW BOTTOM RAIL CONNECTION (Intermediate Rail Similar)

RAIL TERMINATION DETAILS

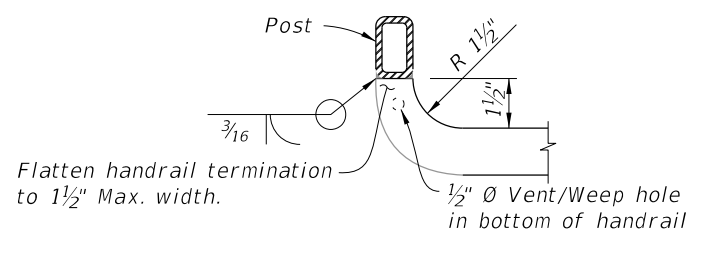

DETAIL "L" - PLAN VIEW HANDRAIL TERMINATION

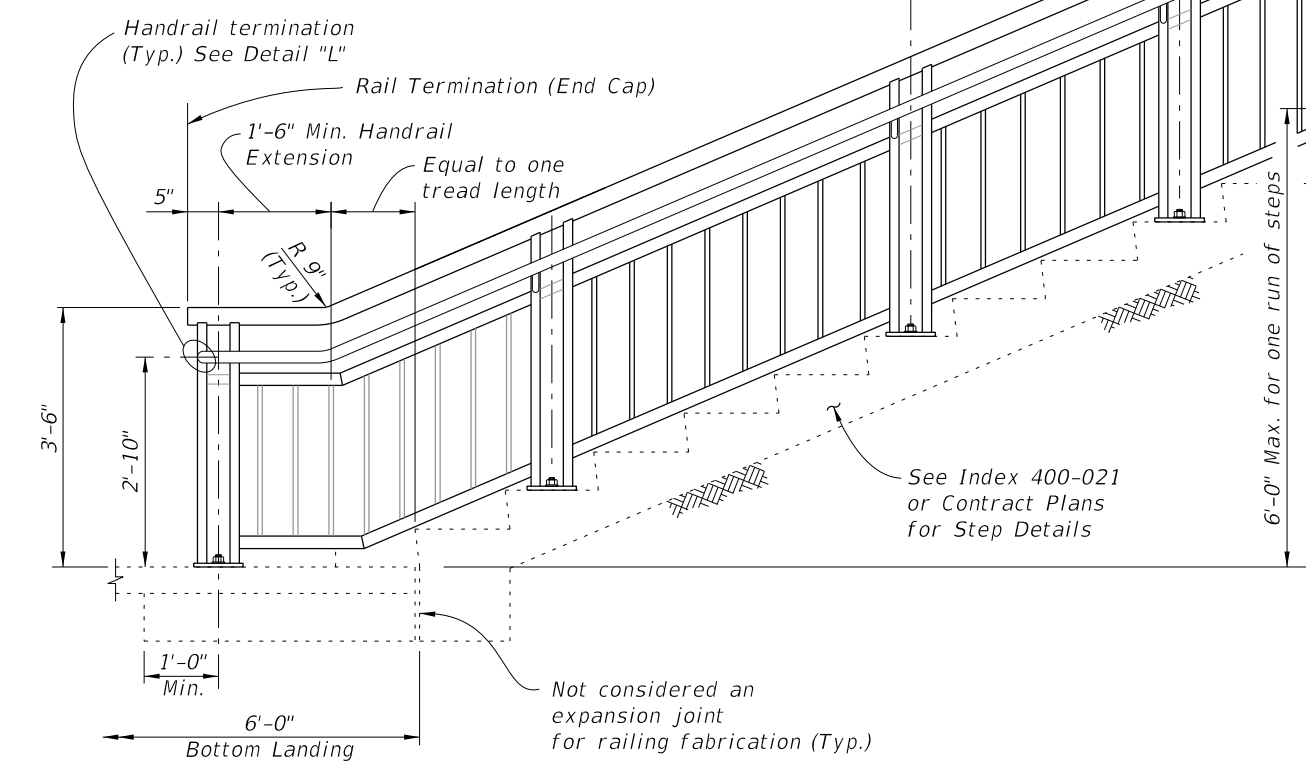

ELEVATION (At-Grade Steps shown, Elevated Stairs similar)

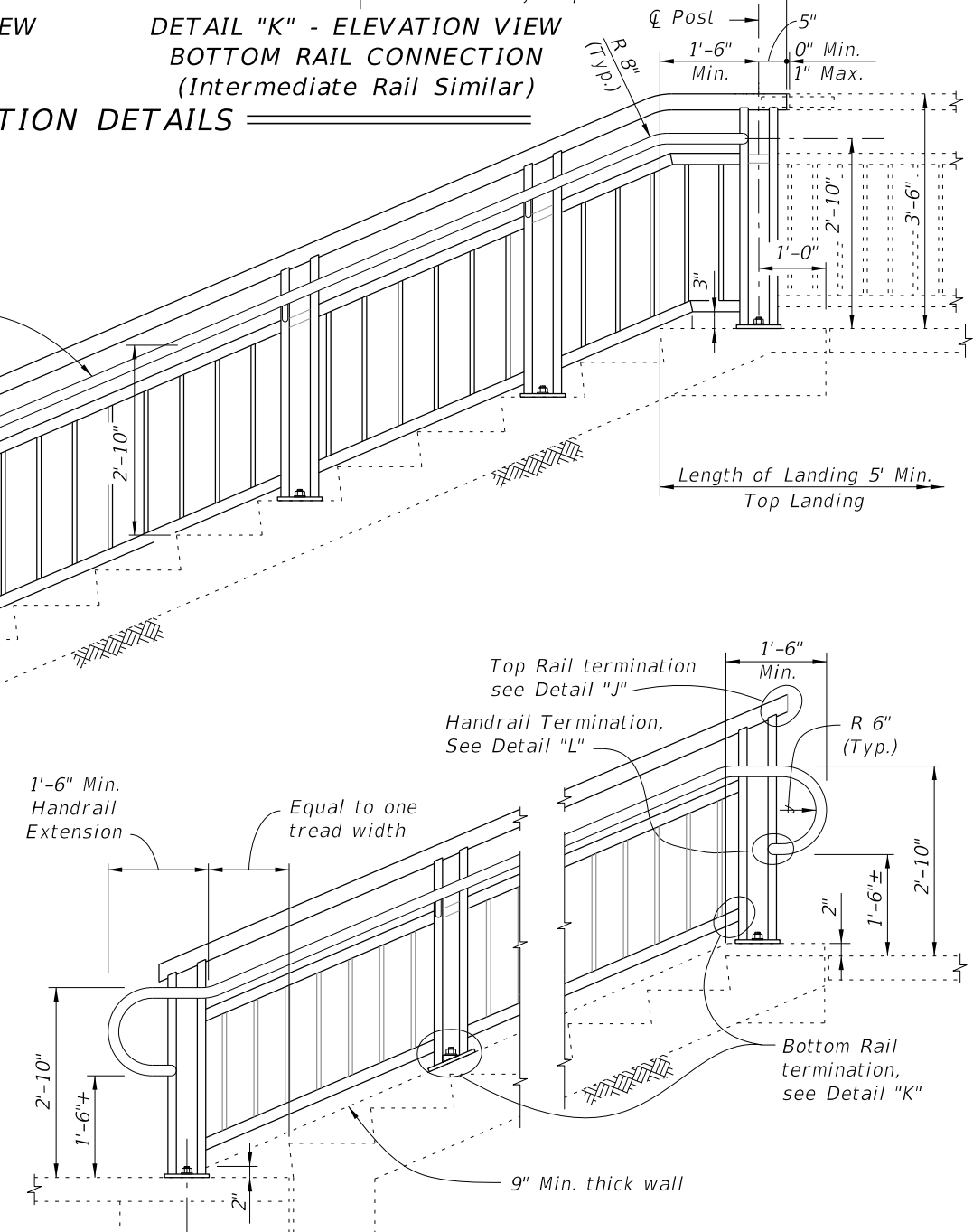

ALTERNATE HANDRAIL END TREATMENT OR MOUNTING LOCATION FOR SLOPED WALLS

RAILINGS ON STEPS & STAIRS

12/13/2022 8:18:01 AM

LAST REVISION 11/01/16	DESCRIPTION:	 FY 2023-24 STANDARD PLANS	PEDESTRIAN/BICYCLE RAILING (STEEL)	INDEX 515-052	SHEET 3 of 8
---------------------------	--------------	--	------------------------------------	------------------	-----------------

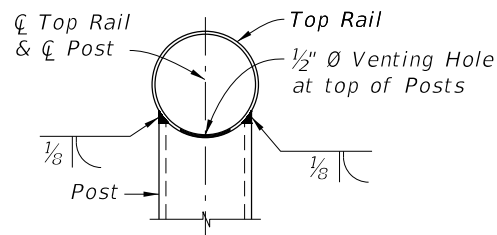

SECTION A-A
(Top Rail Connection)

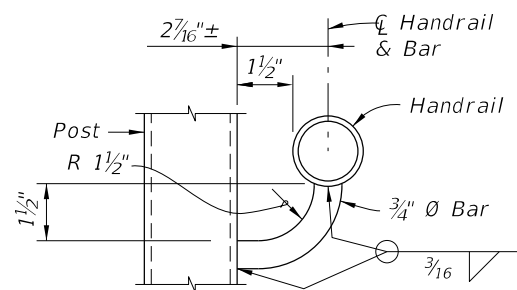

SECTION B-B
(Handrail Connection)

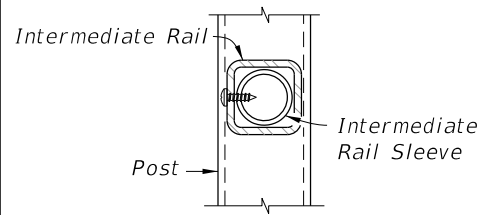

SECTION C-C
(Intermediate Rail Connection)

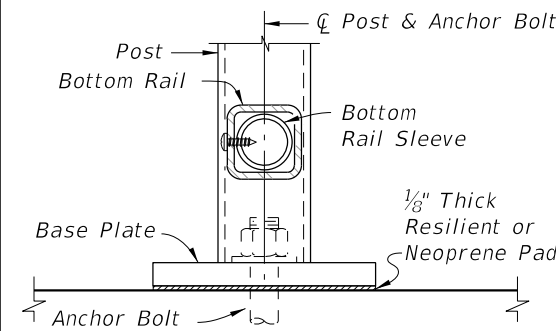

SECTION D-D
(Bottom Rail Connection -
Single Anchor Bolt Shown)

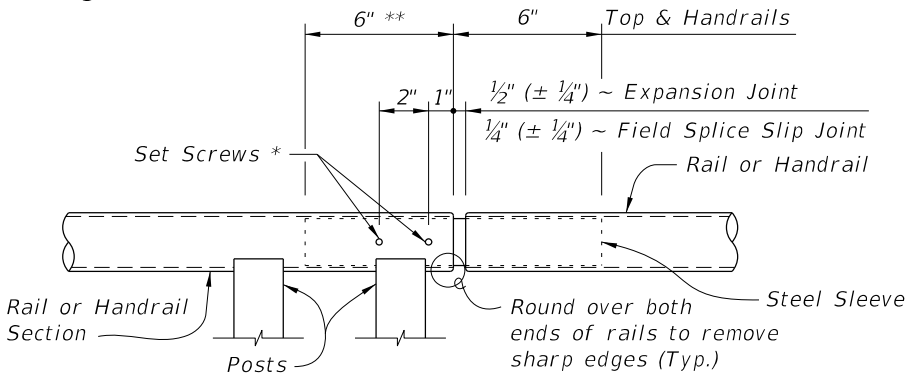

ROUND RAILS - TOP RAIL OR HANDRAIL
(Top Rail at Expansion Joint Shown)

DETAIL "B" - EXPANSION JOINT (FIELD SPLICE SLIP JOINT SIMILAR)

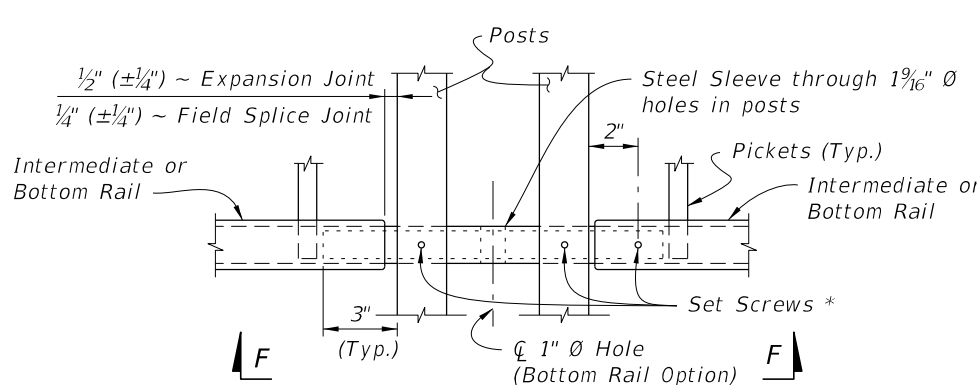

SQUARE RAILS - INTERMEDIATE OR BOTTOM RAIL
(Bottom Rail at Expansion Joint Shown)

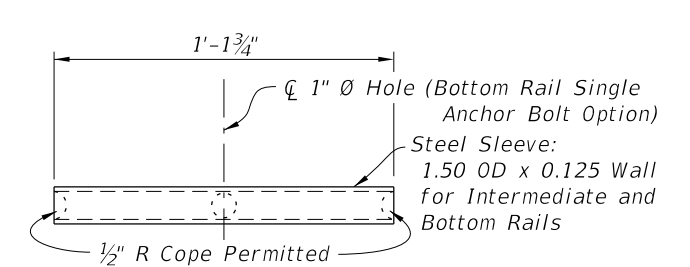

VIEW F-F
INTERMEDIATE OR BOTTOM RAIL -
STEEL SLEEVE DETAIL (Bottom Side Shown)

CROSS REFERENCE:
For location of Details "B", See Sheet 2.

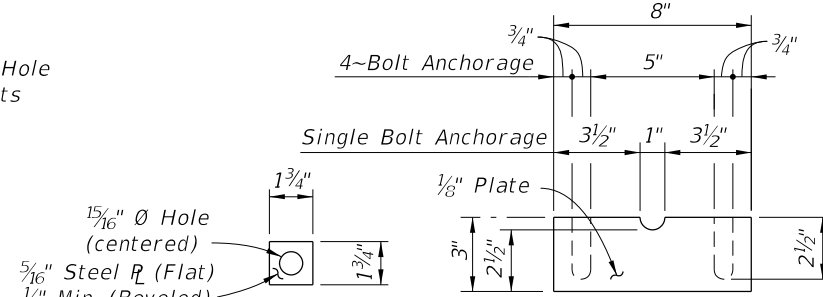
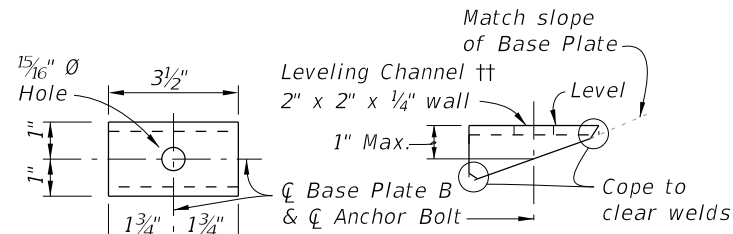

PLATE WASHER DETAIL



SHIM PLATE DETAIL



TOP VIEW

SIDE VIEW

LEVELING CHANNEL DETAIL

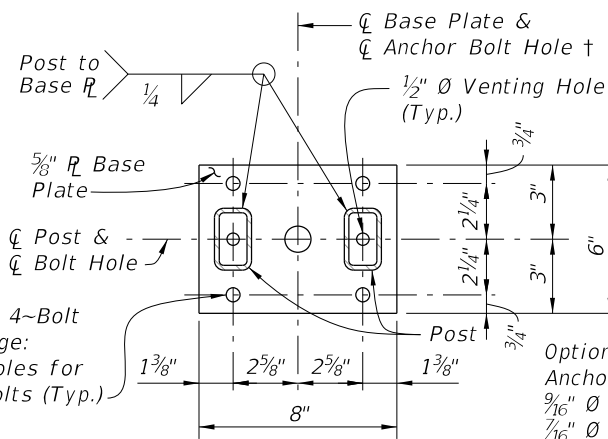

BASE PLATE A

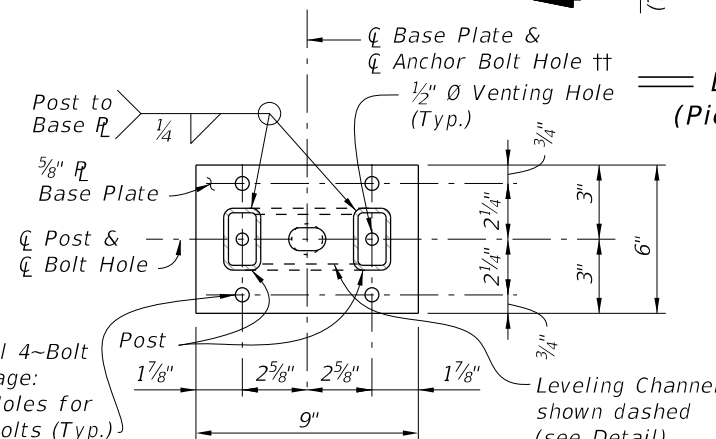

BASE PLATE B

SECTION G-G - BASE PLATE DETAILS

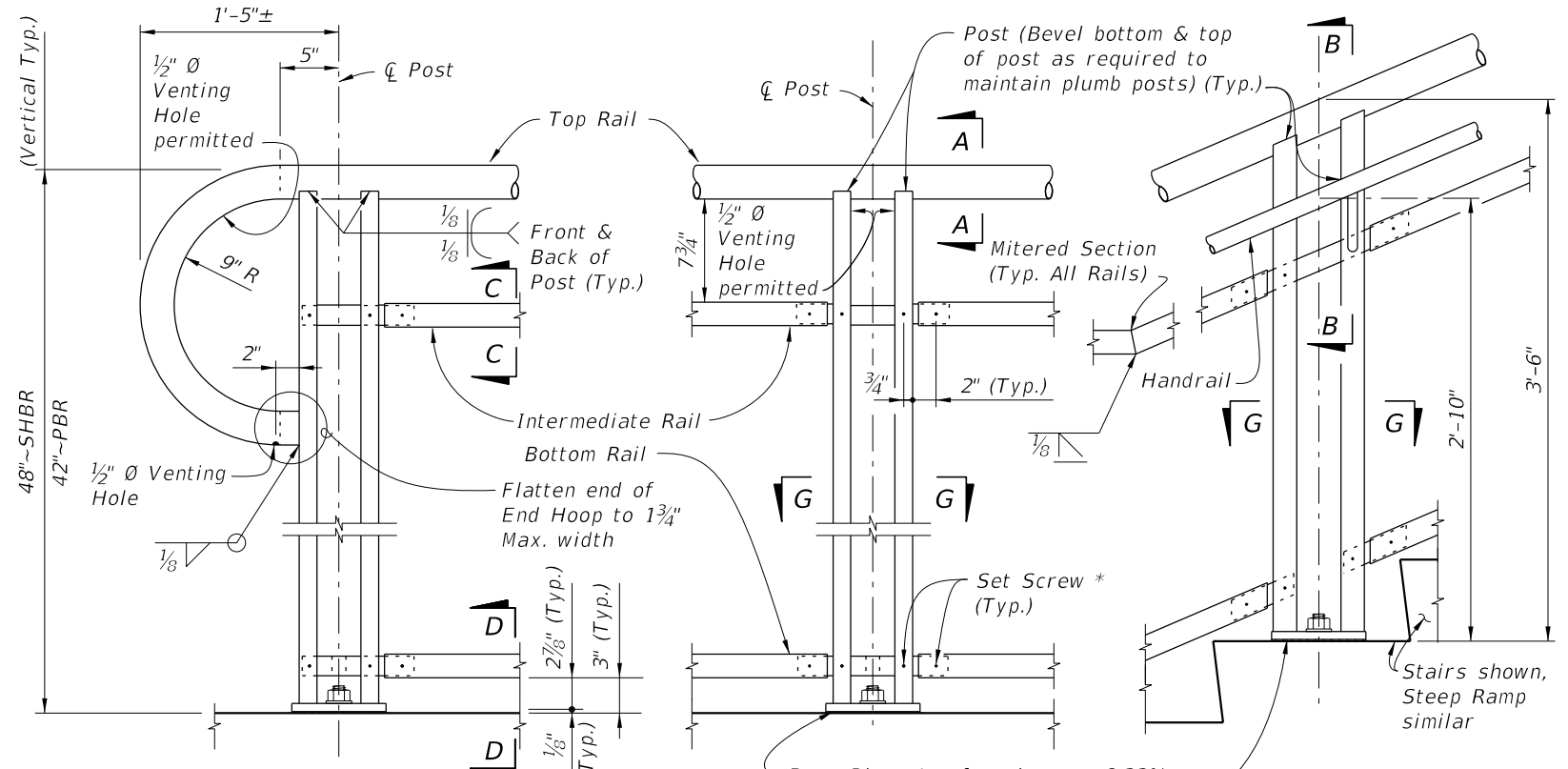

DETAIL "A" - RAIL CONNECTIONS
(Pickets/Panels and 4-Bolt Anchorage
Not Shown for Clarity)

NOTES:

- † Base Plate A (Ramps - Bolts normal) use 1 1/16 inch diameter holes for single anchor bolts with flat washers for slopes ≤ 8.33%.
- ‡ Base Plate B (Stairs - Bolts plumb) use 1 1/4 inch diameter holes for single anchor bolts with beveled plate and washers for slopes > 8.33% to ≤ 15%; use 1 5/16 inch x 1 1/2 inch slotted holes with leveling channel for slopes > 15%.
- * 1/4 inch x 3/4 inch Pan Head Stainless Steel (Type 316 or 18-8 Alloy) Set Screws. Screws must be set flush against the outside face of rails & posts and underside of handrails. 1/2 inch diameter plug welds may be substituted for the set screws. Do not provide set screws for rails at free end of expansion joints.
- ** Embedded length may be 4 inches for plug welded connection.

10/20/2022 8:50:15 AM

LAST REVISION 11/01/16	DESCRIPTION:	 FY 2023-24 STANDARD PLANS	PEDESTRIAN/BICYCLE RAILING (STEEL)	INDEX 515-052	SHEET 4 of 8
---------------------------	--------------	--	------------------------------------	------------------	-----------------

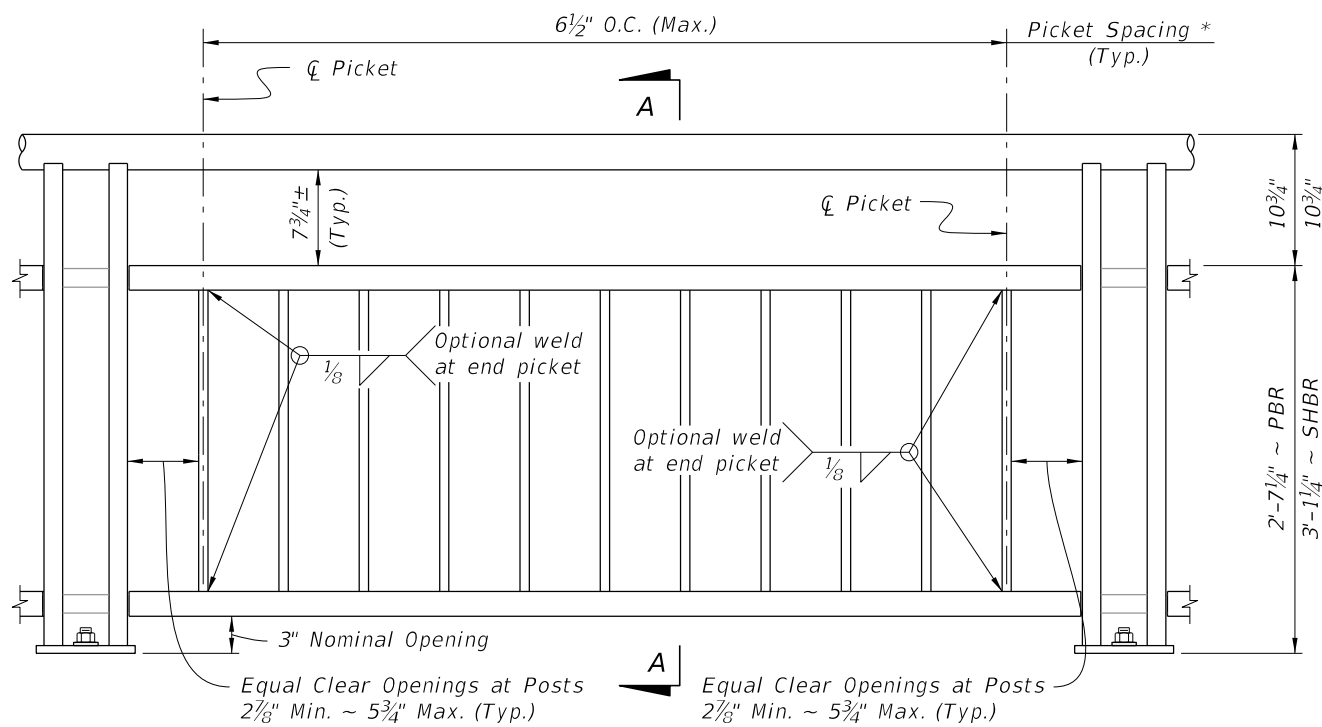

TYPE 1 - PICKET INFILL PANEL

PICKET NOTES:

* Picket Spacing of $6\frac{1}{2}$ " centers is based on a $\frac{3}{4}$ " \varnothing Bar for standard applications. When shown in the Contract Plans a $4\frac{1}{2}$ " picket spacing may be required. See Note 4 (Sheet 1).

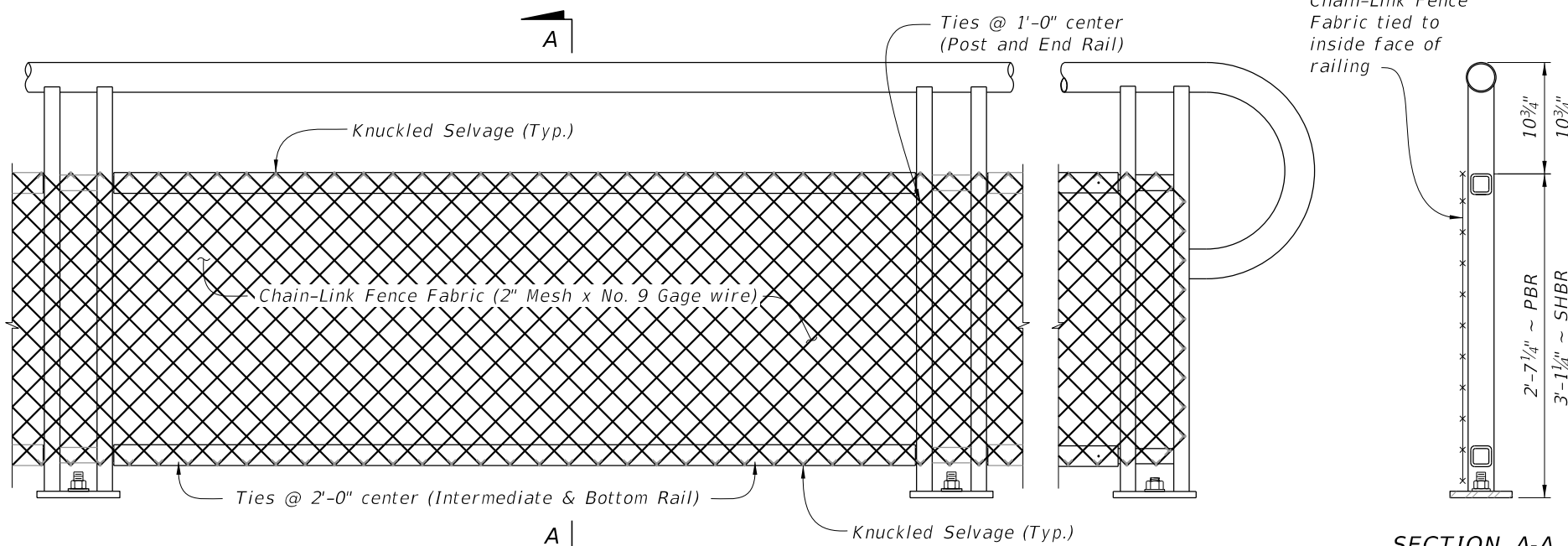

TYPE 2 - CHAIN-LINK (Continuous Infill Panel)

NOTES:

1. See Plans for Infill Panel option required.

SECTION A-A

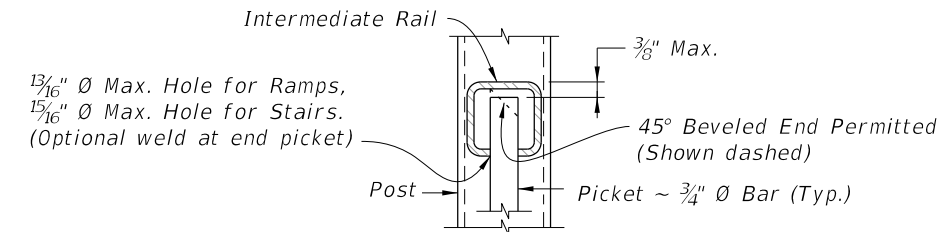

DETAIL "1A" (Top of Picket Connection)

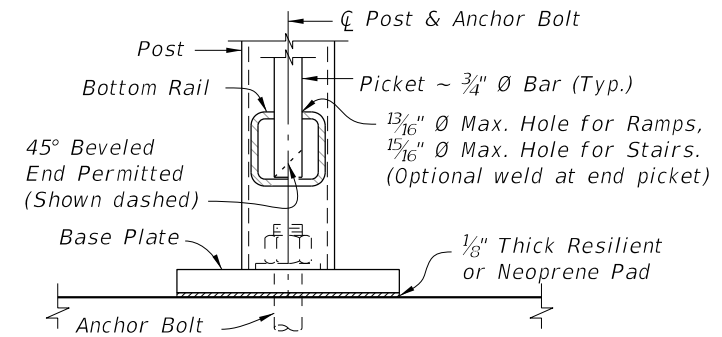

DETAIL "1B" (Bottom of Picket Connection)

SECTION A-A

TABLE 2 - CHAIN-LINK PANEL COMPONENT MATERIALS		
COMPONENT	ASTM	COMPONENT INFORMATION
Chain-Link Fence Fabric (2" mesh with knuckled top and bottom selvage)	A 392	Zinc-Coated Steel - No. 9 gage (coated wire diameter), Class 2 Coating
	A 491	Aluminum-Coated Steel - No. 9 gage (coated wire diameter)
	F 668	Polyvinyl Chloride (PVC) Coated Steel - No. 9 gage Zinc-Coated Wire (metallic-coated core wire diameter) ~ See Plans for specified color of PVC.
Tie Wires	F 626	Zinc-Coated Steel Wire - No. 9 gage with coating to match Chain-Link Fence Fabric.
Tension Bars	F 626	$\frac{3}{16}$ " (Min. thickness) x $\frac{3}{4}$ " (Min. width) x 2'-3' (Min. height) Steel Bars
Miscellaneous Fence Components	F 626	Zinc-Coated Steel

CHAIN-LINK PANEL NOTE:

Chain-Link Fence Fabric shall be continuous along limits of railing. Splicing of Chain-Link panels using Tension Bars at 20'-0" minimum increments is permitted.

10/20/2022 8:50:16 AM

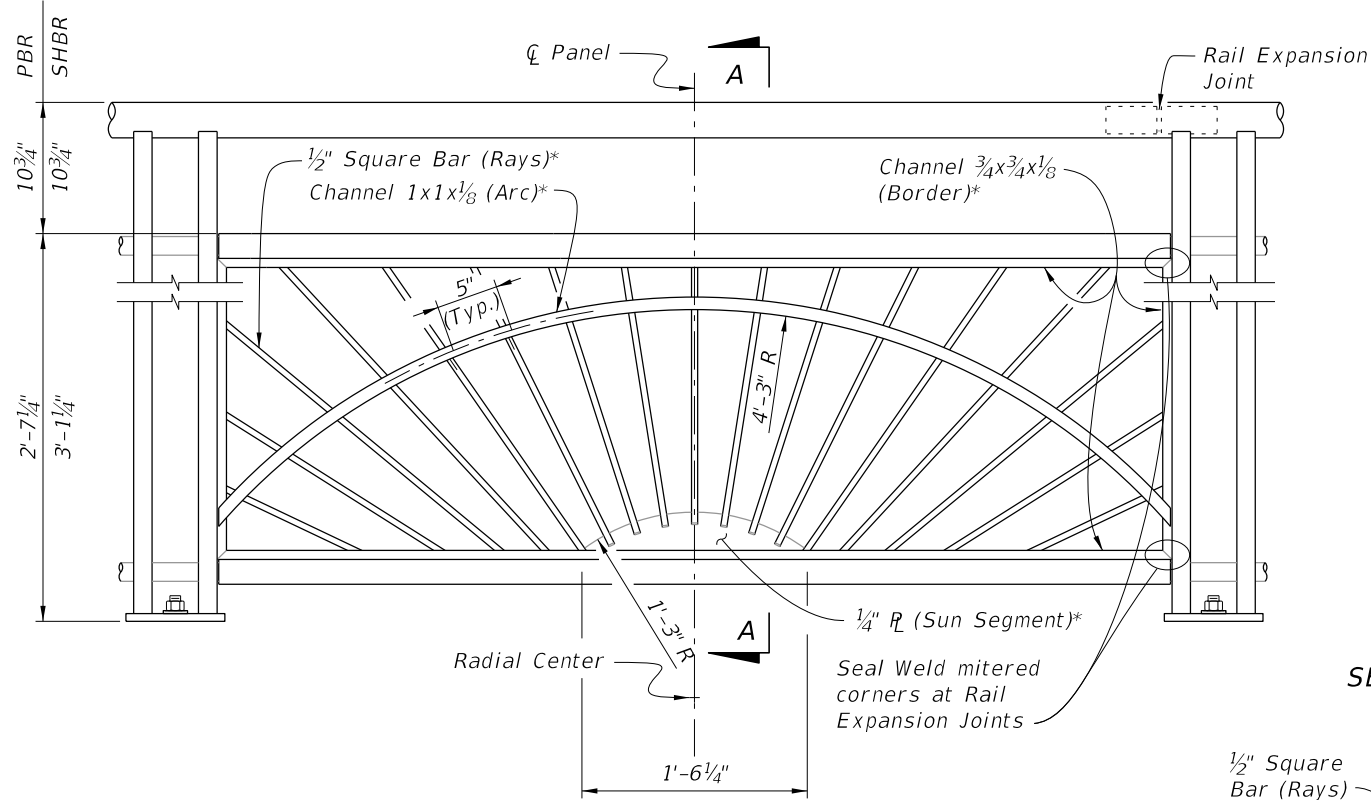

TYPE 3 - SUNSHINE INFILL PANEL

* Arc, Rays and Sun Segment may be formed in a single panel from 1/2" steel plate pattern cut with laser or plasma CNC, welded to a 1x1x1/8 Angle Border or the 3/4x3/4x1/8 Channel Border shown.

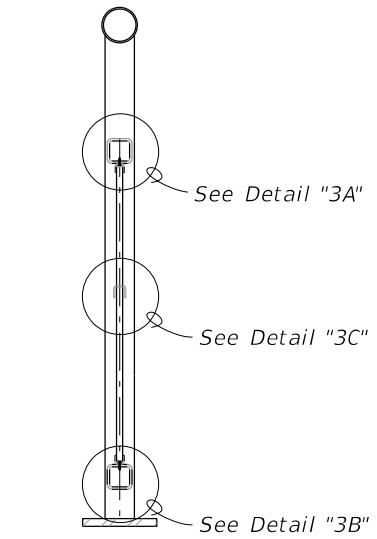

SECTION A-A

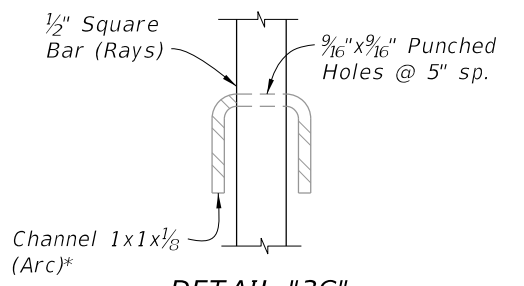

DETAIL "3C" RAY/ARC CONNECTION

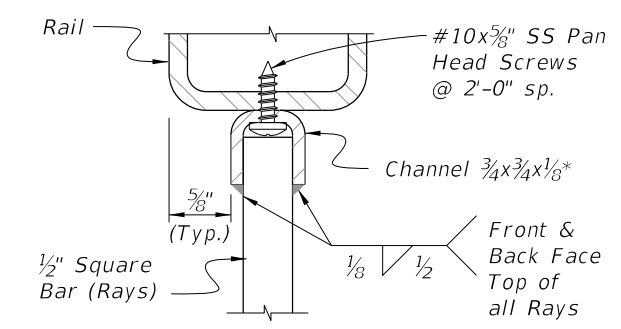

DETAIL "3A" INTERMEDIATE RAIL/RAY CONNECTION

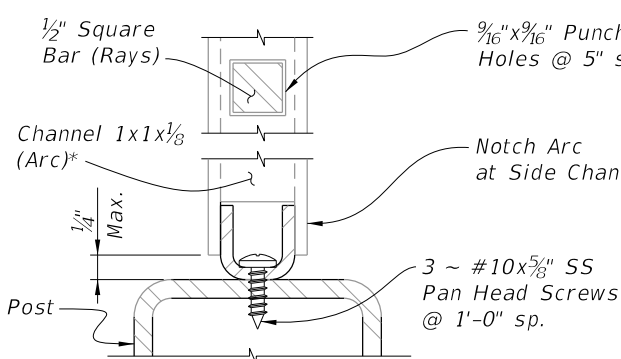

DETAIL "3D" ARC/POST CONNECTION (Continuous Top Rail)

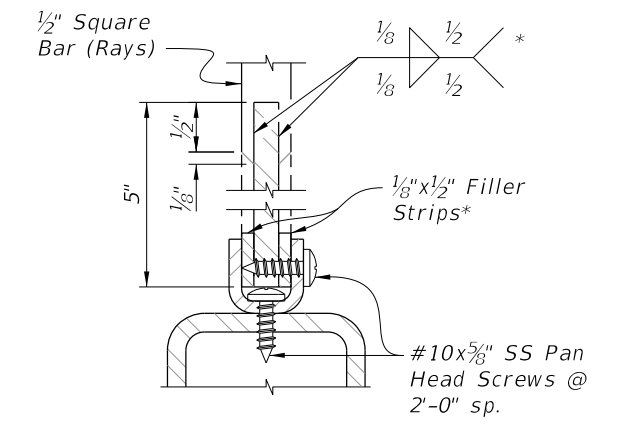

DETAIL "3B" BOTTOM RAIL/RAY CONNECTION

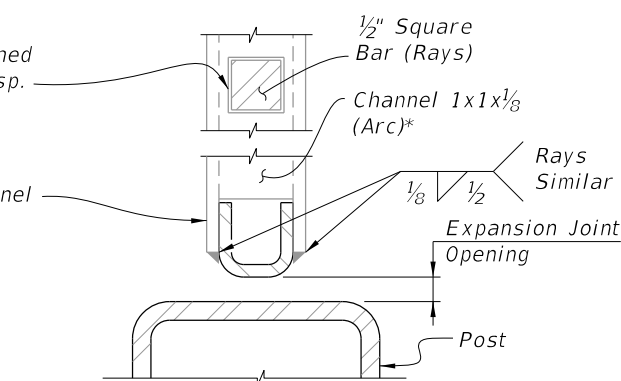

DETAIL "3E" PANEL END CONNECTION AT POST WITH EXPANSION JOINT

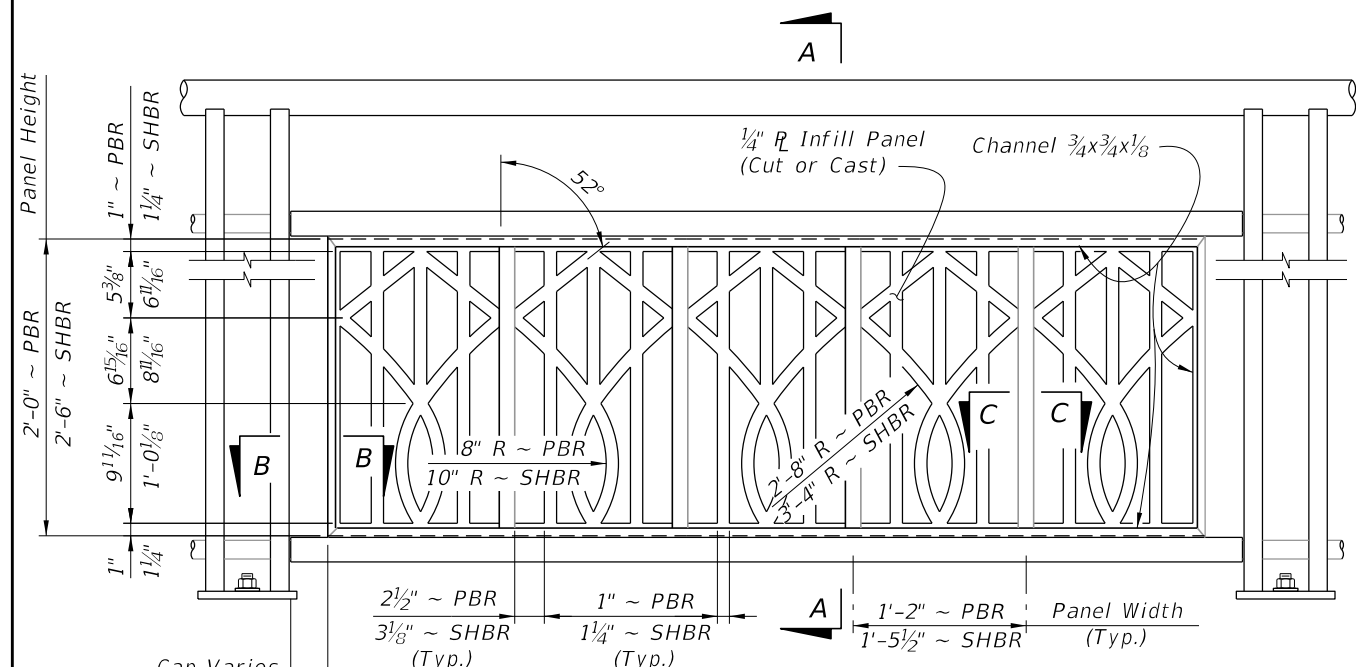

TYPE 4 - BROADWAY INFILL PANEL

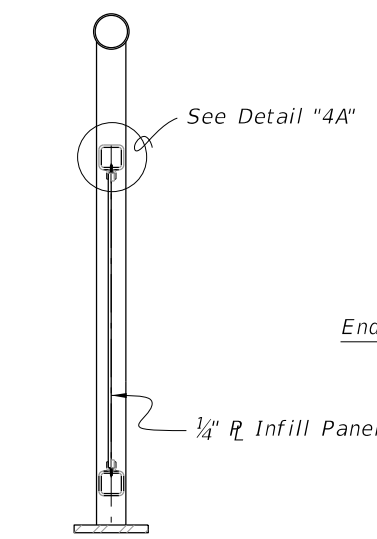

SECTION A-A

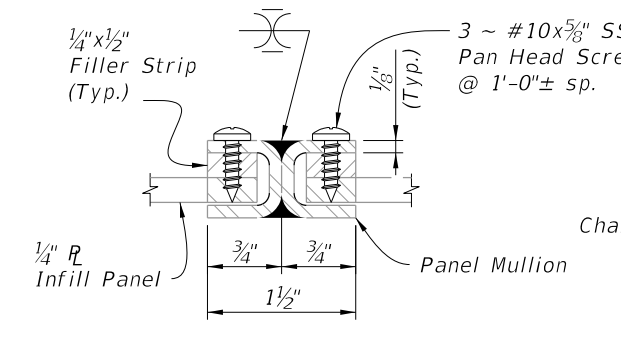

SECTION C-C PANEL/SPLICE CONNECTION

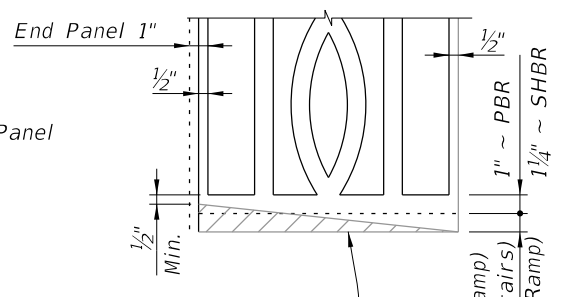

PANEL ADJUSTMENT FOR RAILINGS ON GRADES

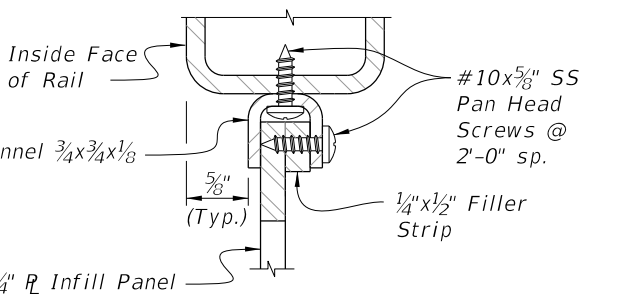

DETAIL "4A" PANEL/RAIL CONNECTION (Top Shown, Bottom Similar)

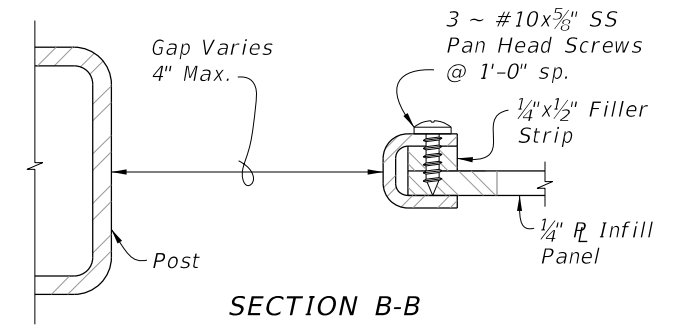

SECTION B-B PANEL END CAP

NOTE:
See Plans for Infill Panel Option required.

10/20/2022 8:50:17 AM

LAST REVISION 11/01/16	DESCRIPTION:		FY 2023-24 STANDARD PLANS	PEDESTRIAN/BICYCLE RAILING (STEEL)	INDEX 515-052	SHEET 6 of 8
---------------------------	--------------	--	--------------------------------------	---	------------------	-----------------

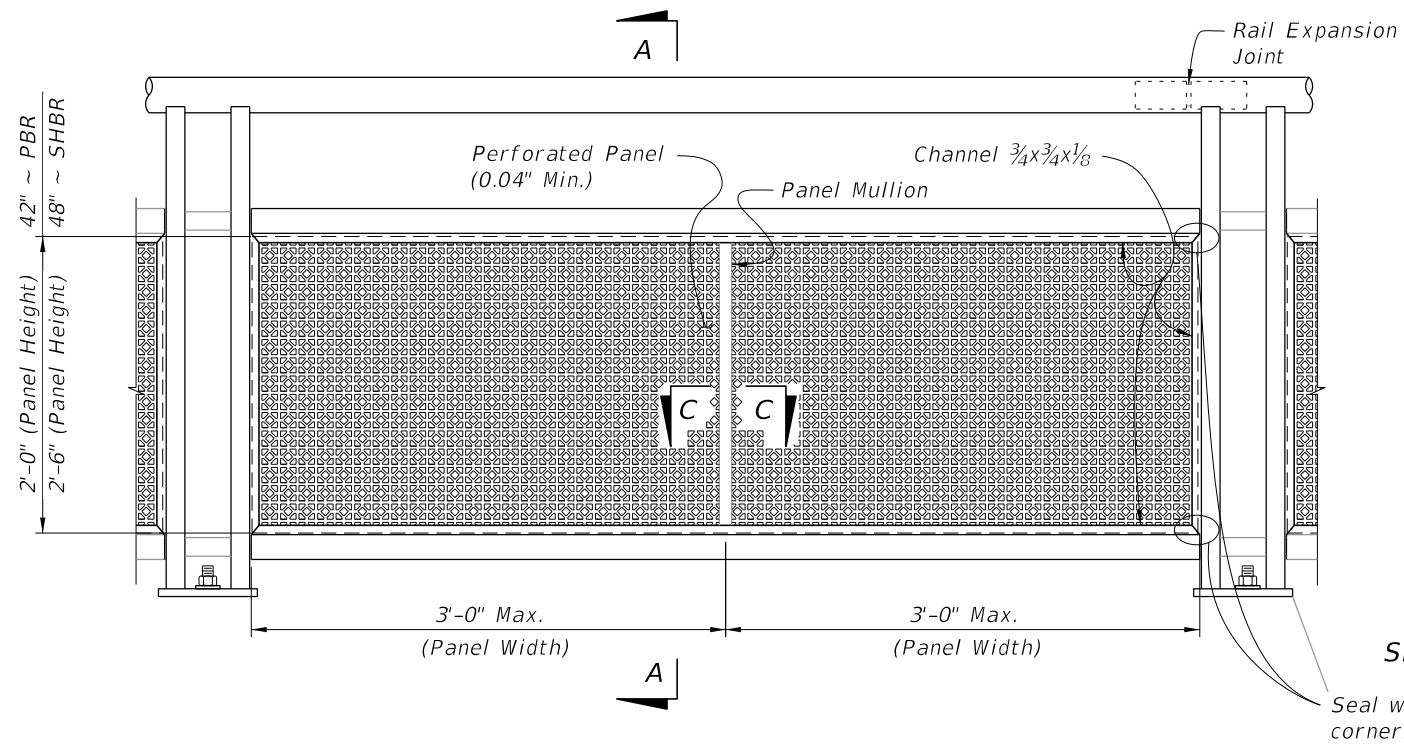

TYPE 5 - PERFORATED INFILL PANEL

SECTION A-A

Seal welding mitered corners is permitted

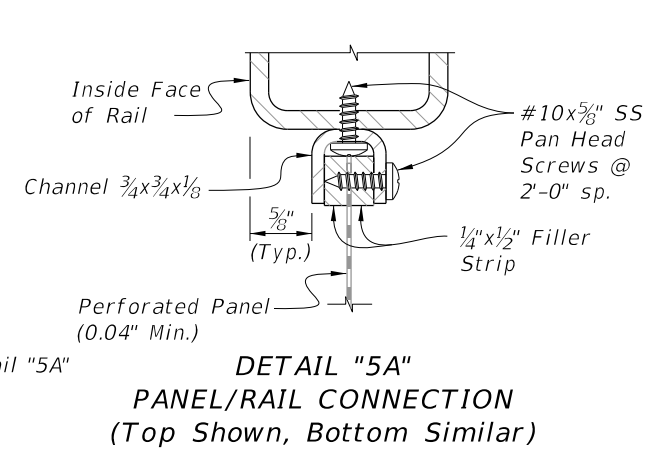

DETAIL "5A"
PANEL/RAIL CONNECTION
(Top Shown, Bottom Similar)

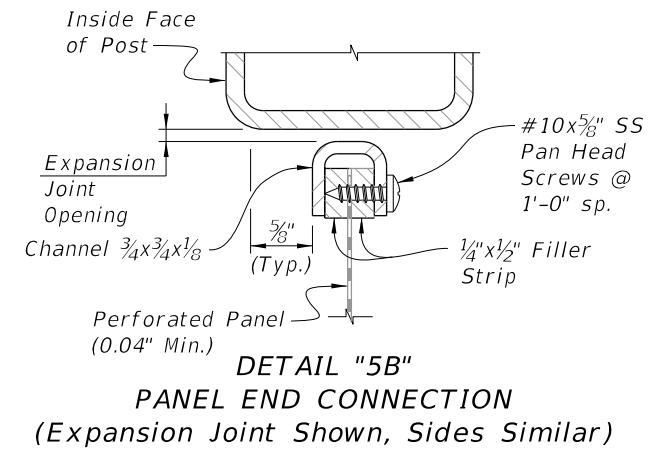

DETAIL "5B"
PANEL END CONNECTION
(Expansion Joint Shown, Sides Similar)

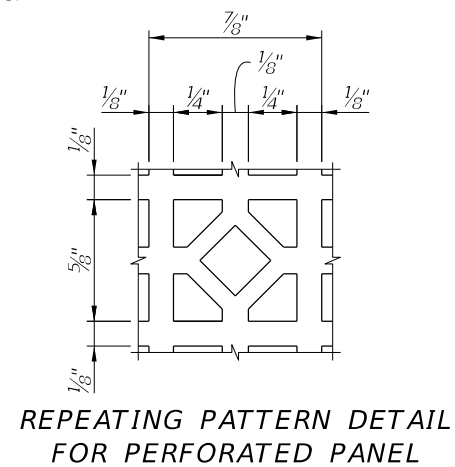

REPEATING PATTERN DETAIL
FOR PERFORATED PANEL

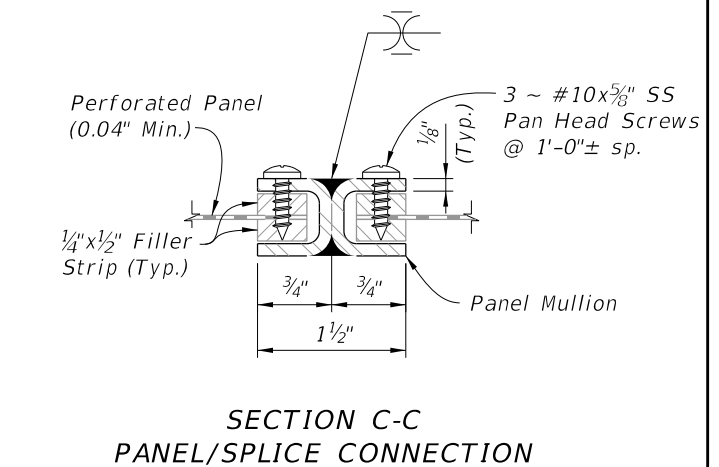

SECTION C-C
PANEL/SPLICE CONNECTION

NOTES:

1. See Plans for Infill Panel Type required.

10/20/2022 8:50:17 AM

LAST REVISION 11/01/16	REVISION	DESCRIPTION:		FY 2023-24 STANDARD PLANS	PEDESTRIAN/BICYCLE RAILING (STEEL)	INDEX 515-052	SHEET 7 of 8
---------------------------	----------	--------------	--	------------------------------	------------------------------------	------------------	-----------------

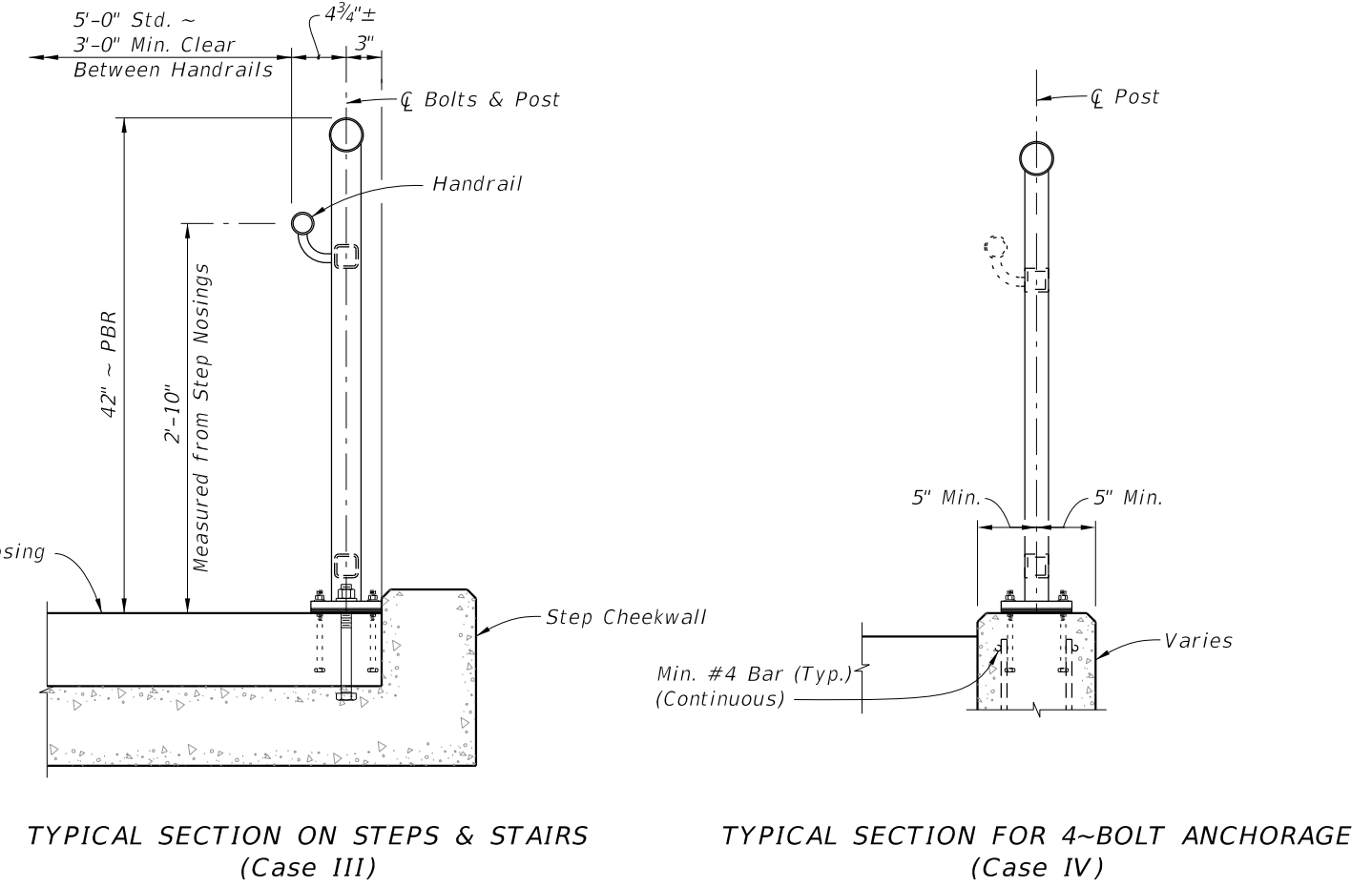
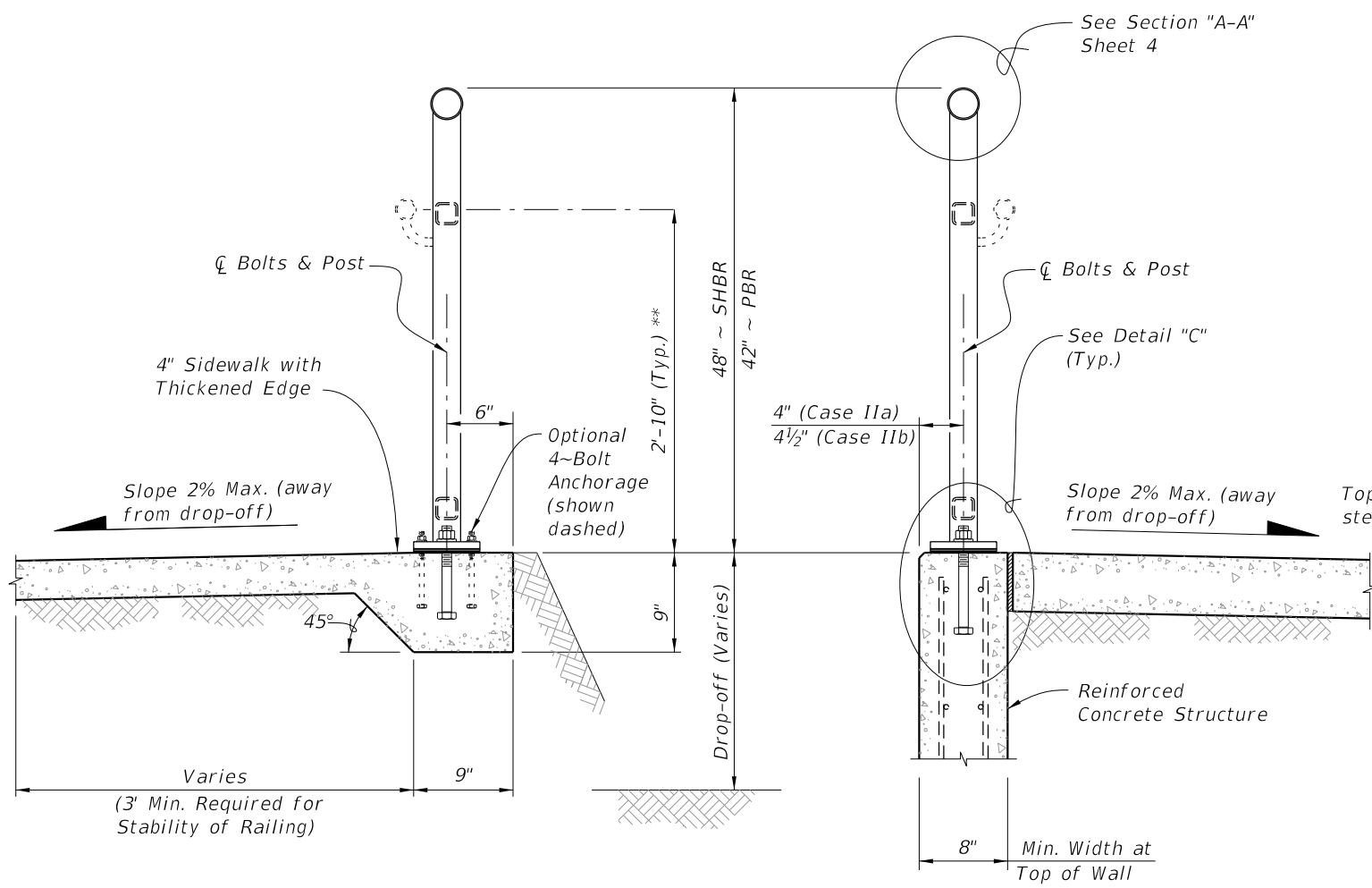

TYPICAL SECTION ON CONCRETE SIDEWALK (Case I)

TYPICAL SECTION ON RETAINING WALL (Case II)

TYPICAL SECTION ON STEPS & STAIRS (Case III)

TYPICAL SECTION FOR 4-BOLT ANCHORAGE (Case IV)

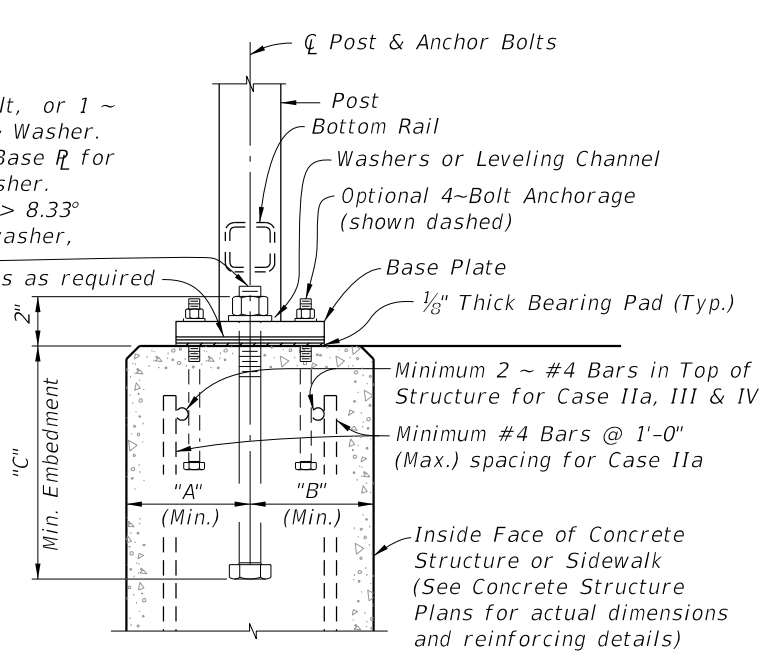
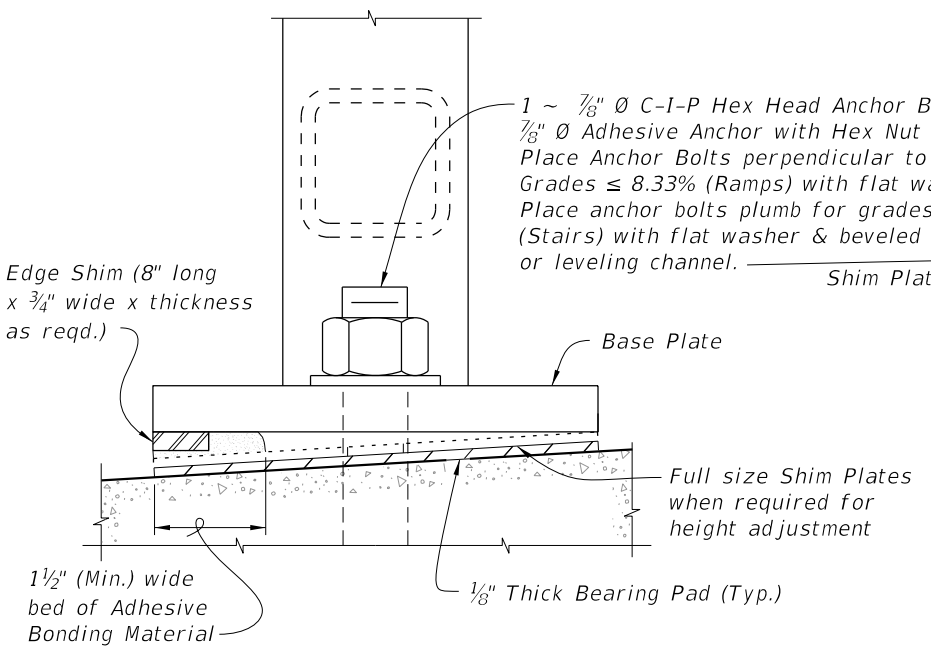

CASE	STRUCTURE TYPE	DIMENSIONS			ANCHOR LENGTH		ANCHOR SIZE
		A	B	C	C-I-P Hex Head Bolt	Adhesive Anchor	
		Edge Dist.	Edge Dist.	Embedment			
I	Unreinforced Concrete	6"	1'-2"	6"	7 1/2"	8"	7/8" Ø
IIa	Reinforced Concrete	4"	4"	9"	10 1/2"	11"	7/8" Ø
IIb	Gravity Wall Index 400-011	4 1/2"	3 1/2" @ top	9"	10 1/2"	11"	7/8" Ø
III	Step Cheekwall	4 1/2"	4 1/2"	9"	10 1/2"	11"	7/8" Ø
IV	Varies	5"	5"	5"	6 1/2"	7"	7/16" Ø

** When required; measured from top of sidewalk.

10/20/2022 8:50:19 AM

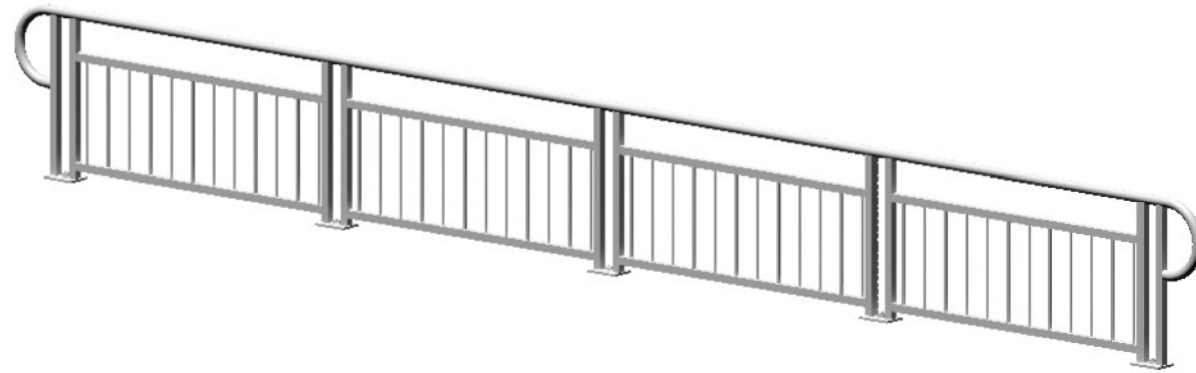

3D VIEW OF RAILING WITH TYPE 1 - PICKET INFILL PANEL
(42" Height shown, 48" Height Similar)

TABLE 1 - RAILING MEMBERS

MEMBER	ALLOY ⁽¹⁾	DESIGNATION	OUTSIDE DIMENSION	WALL THICKNESS
Posts (Type "A" & "B")	6061-T6	RT 2x2x0.250	2.00" x 2.00"	0.250"
Posts (Type "C")	6061-T6	Extrusion 1½x2½x0.125	1.50" x 2.50"	0.125"
Top Plate (Type "C")	6061-T6	Extrusion (See Details)	2¾" x 7"	Varies
Top Rail	6061-T6	2½" NPS (Sch. 10) 3" Round Top Cap Rail	2.875" 3.000"	0.120" 0.125"
End Hoops	6063-T5	2½" NPS (Sch. 10) 3.00 OD x 0.125 Wall	2.875" 3.000"	0.120" 0.125"
Top Rail Joint/Splice Sleeves	6063-T5	2.50 OD x 0.125 Wall Top Cap Rail Inner Sleeve	2.500" 2.800"	0.125" 0.090"
Intermediate & Bottom Rail	6061-T6	RT 2x2x0.250	2.00" x 2.00"	0.250" ⁽²⁾
Int. & Bottom Rail Post Connection Sleeve	6063-T5	1.50 OD x 0.125 Wall ⁽³⁾	1.500"	0.125"
Handrail Joint/Splice Sleeves	6063-T5	1" NPS (Sch. 40) 1.50 OD x 0.125 Wall	1.315" 1.500"	0.133" 0.125"
Handrails	6061-T6	1½" NPS (Sch. 40)	1.900"	0.145"
Handrail Support Bar	6061-T6	¾" Ø Round Bar	0.750"	N/A
Pickets (Type 1 Infill Panel)	6061-T6	¾" Ø Round Bar	0.750"	N/A
Infill Panel Members (Types 2 - 5)	6063-T5	Varies (See Details)	Varies	Varies

TABLE 1 NOTES:

- (1) Alloy 6061-T6 or 6063-T52 & T6 may be substituted for Alloy 6063-T5.
- (2) 0.188" wall thickness permitted for rails with post spacings less than 5'-9".
- (3) 1" NPS (Sch. 40) non-slit rail sleeves may be substituted when welded connection Detail "K" is utilized.

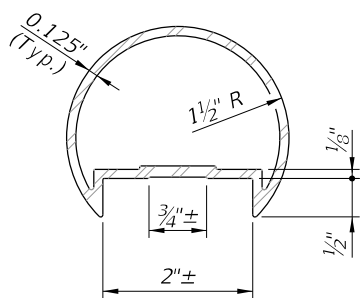

3" ROUND TOP CAP RAIL
TOP CAP RAIL INNER SPLICE SLEEVE
ALTERNATE TOP RAIL SECTION

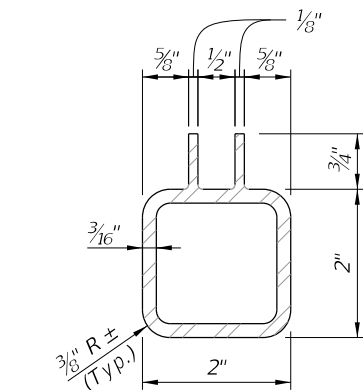
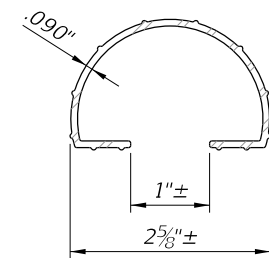

ALTERNATIVE BOTTOM & INTERMEDIATE RAIL SECTION FOR TYPE 3, 4 & 5 RAILINGS

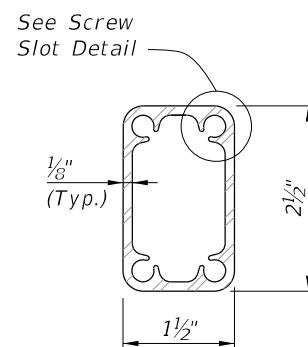

POST TYPE "C" SCREW SLOT SECTION

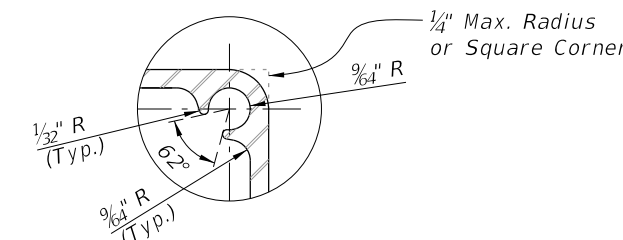

SCREW SLOT DETAIL

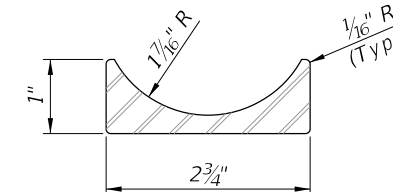

OPTIONAL TOP PLATE EXTRUSION SECTION (POST TYPE "C")

CROSS REFERENCES:

- Detail "A", Sheet 4
- Detail "B", Sheet 4
- Detail "K", Sheet 3

NOTES

1. Shop Drawings are required, see Specification Section 515.
2. For bridge mounted railings, work this Index with Index 515-061 Bridge Bicycle/Pedestrian Railing (Aluminum)
3. Materials:
 - A. Structural Extrusions, Tube, Pipe and Bars: Table 1 and ASTM B221 or ASTM B429
 - a. Top, bottom and intermediate rail corner bends with maximum 4'-0" post spacing may be Alloy 6063-T6
 - B. Base Plates and Rail Caps: ASTM B209 Alloy 6061-T6
 - C. Perforated panels (Type 5) Alloy 3003-H14
 - D. Stainless steel (SS) screws: Type 316 or 18-8 Alloy
 - E. Aluminum screws: Alloy 2024-T4 or 7075-T73
 - F. Galvanized Steel Fasteners: coated in accordance with Specification Section 962.
 - a. Hex Head Bolts: ASTM A 307
 1. 7/8" diameter single bolt option, Grade 36
 2. 7/16" diameter four bolt option, Grade 55
 - b. Adhesive Anchors: ASTM F1554 fully threaded rods, Grade 55
 - c. Hex Nuts: ASTM A563
 - d. Flat Washers: ASTM F436
 - e. Plate Washers: ASTM A36 or ASTM A706 Grade 36.
 - G. Shims: ASTM B209 Alloy 6061 or 6063
 - H. Bearing Pads: Provide 1/8" thick Plain, Fabric Reinforced or Fabric Laminated Bearing Pads meeting the requirements of Specification Section 932 for Ancillary Structures.
4. Fabricate pickets and vertical panel elements parallel to the posts; except Type 2, 3 and 5 panel infills may be fabricated parallel to the longitudinal grade. Maintain a maximum clear opening of 5/8" for standard installations and 3/8" when a 4" sphere requirement is indicated in the Data Tables.
5. Locate railing expansion joints between the posts on either side of the deck expansion joint. Maximum spacing between expansion joints is 35'-0".
6. Field splices are similar to the Expansion Joint Detail and may be approved by the Engineer to facilitate handling; but the top rail must be continuous across a minimum of two posts.
7. For intermediate and bottom horizontal rails, the screwed joints shown may be substituted with alternate joints shown in detail "K" for Post Type "A" & "B".
8. Make corners and changes in tangential longitudinal alignment with a 9" bend radius or terminate adjoining sections with mitered end sections when handrails are not required.
9. For changes in tangential longitudinal alignment greater than 45°, position posts a maximum of 2'-0" each side of the corner but not at the corner apex.
10. For curved longitudinal alignments, shop bend the top and bottom rails and handrails to match the alignment radius.
11. Handrails are required and must be continuous at landings for:
 - A. Grades Steeper than 5%
 - B. Three or more steps
12. Installation: Cutting of reinforcing steel is permitted for post installed anchors.

10/20/2022 8:50:20 AM

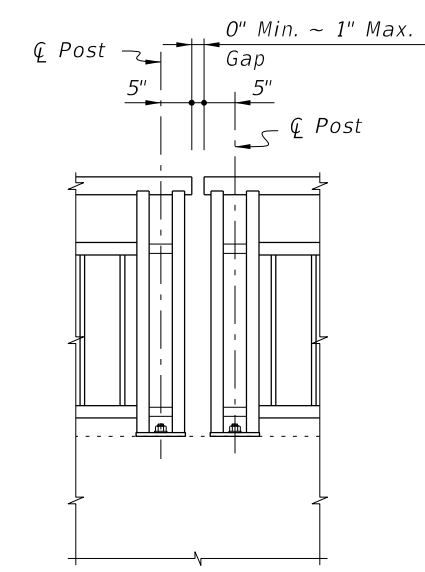
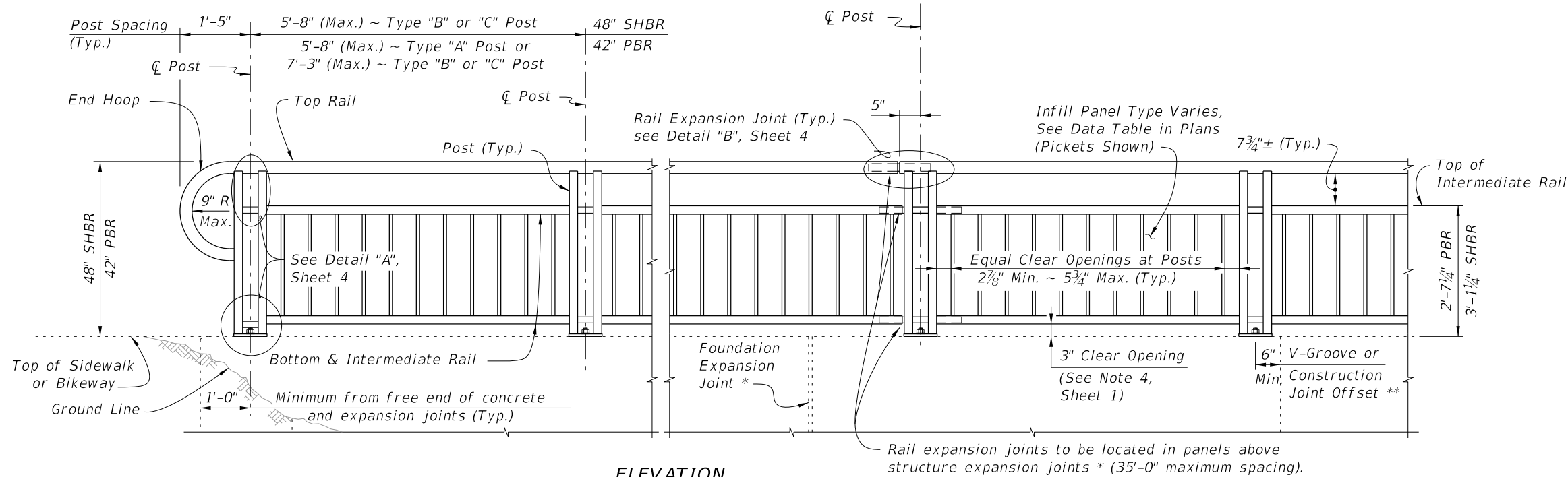

Note: Non-continuous corners are permitted when handrails are not required.

ELEVATION
(Showing Outside Face of Railing with Type "A" Posts)

EXPANDED ELEVATION AT CORNERS
DETAIL FOR NON-CONTINUOUS RAILING AT CORNERS

TYPICAL RAILING DETAILS & RAILINGS ON GRADES 0% TO 5%
(Type 1 - Picket Railing Shown, Other Types Similar)

- NOTES:**
- * Keyed construction joints in Index 400-011 Gravity Wall are not considered to be expansion joints.
 - ** Contraction joints (Tooled or Saw Cut) in sidewalks do not require a 6" minimum offset.

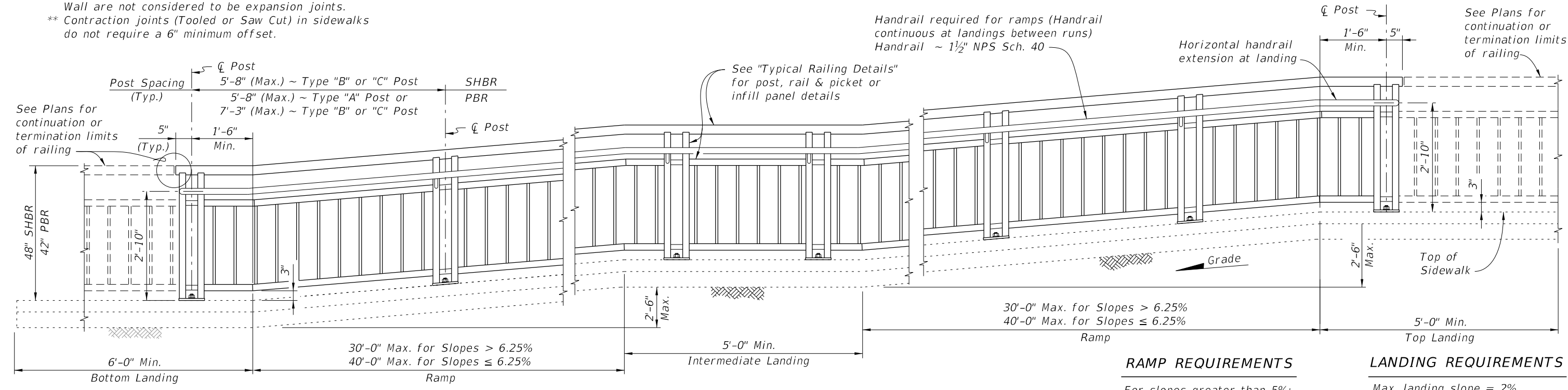

RAMP REQUIREMENTS

For slopes greater than 5%:
Max. ramp slope = 8.33%
Max. ramp cross-slope = 2.0%

LANDING REQUIREMENTS

Max. landing slope = 2%
Max. landing cross-slope = 2%

ELEVATION
(Showing Inside Face of Railing with Type "A" Posts)

RAILINGS ON GRADES STEEPER THAN 5%
(Type 1 - Picket Railing Shown, Other Types Similar)

10/20/2022 8:50:21 AM

LAST REVISION 11/01/15	DESCRIPTION:		FY 2023-24 STANDARD PLANS	PEDESTRIAN/BICYCLE RAILING (ALUMINUM)	INDEX 515-062	SHEET 2 of 9
REVISION						

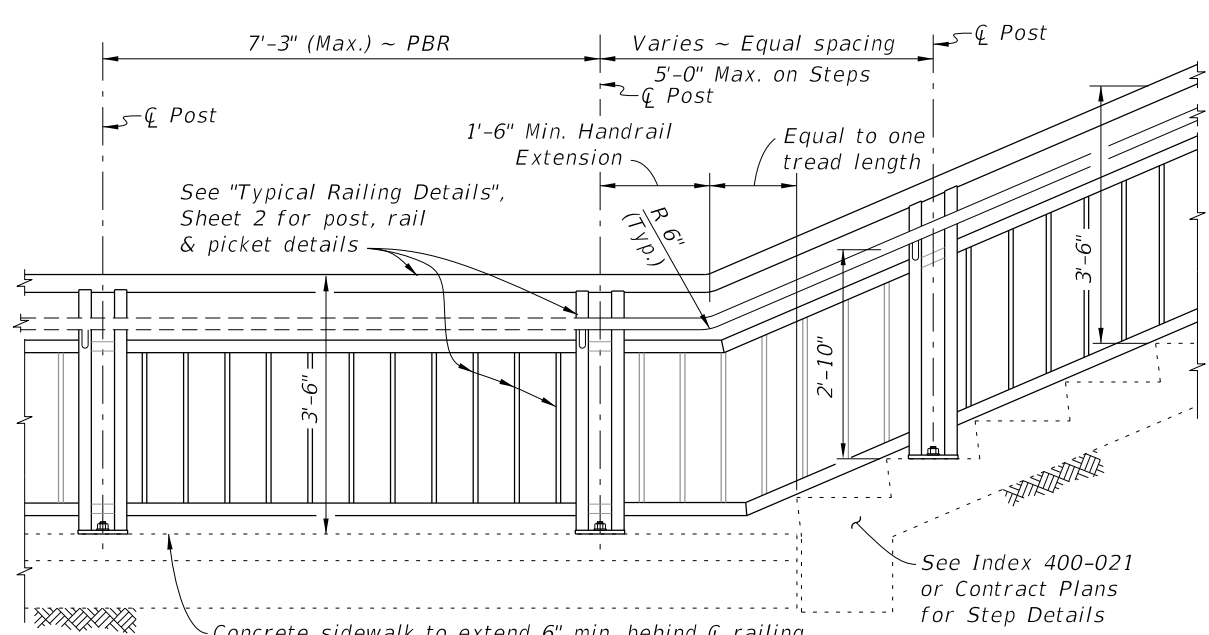

RAILING CONTINUATION BEYOND STEPS OR STAIRS
(Bottom shown, Top similar)

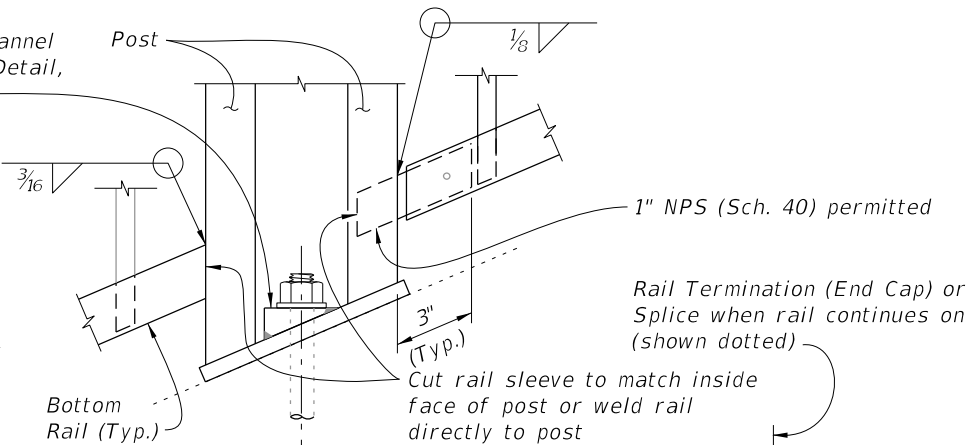
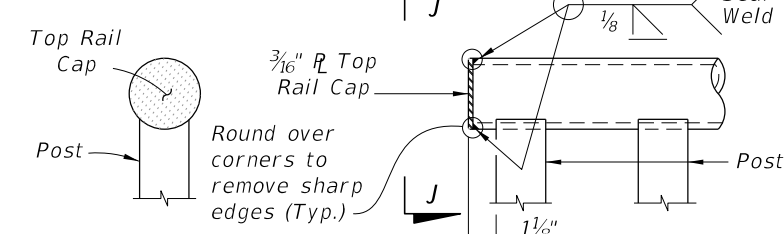

RAIL TERMINATION DETAILS

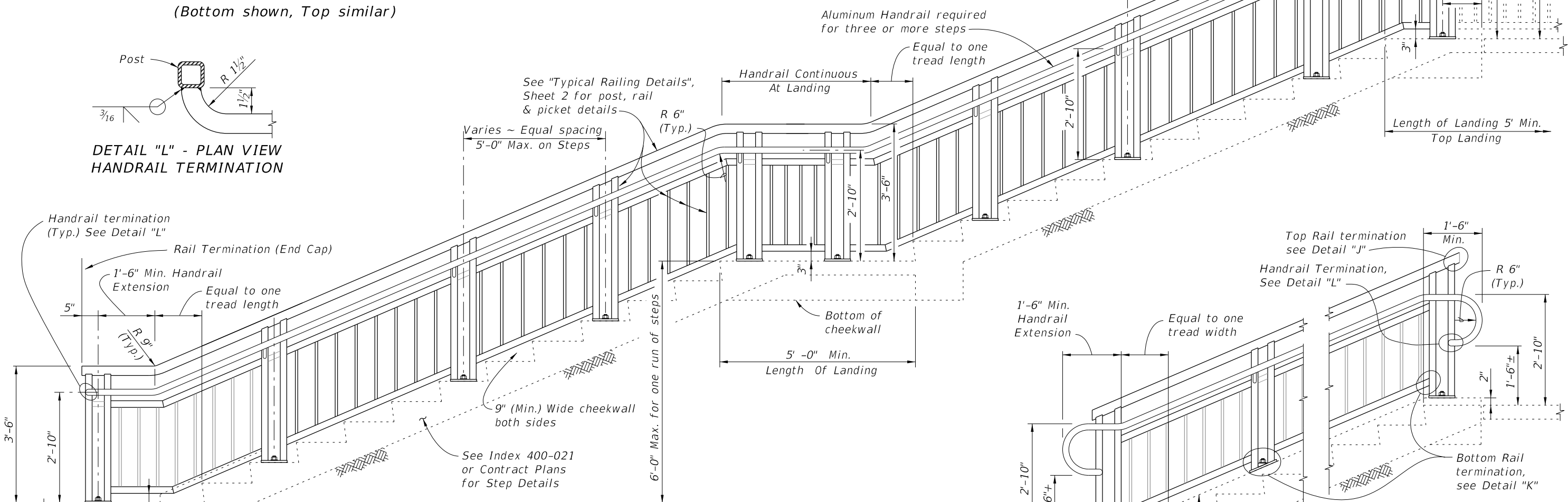
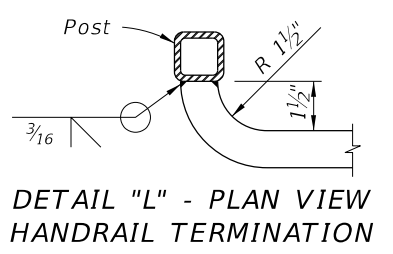

ELEVATION
(At-Grade Steps shown, Elevated Stairs similar)

ALTERNATE HANDRAIL END TREATMENT OR MOUNTING LOCATION FOR SLOPED WALLS

RAILINGS ON STEPS & STAIRS

10/20/2022 8:50:22 AM

LAST REVISION 11/01/16	DESCRIPTION:	FDOT	FY 2023-24 STANDARD PLANS	PEDESTRIAN/BICYCLE RAILING (ALUMINUM)	INDEX 515-062	SHEET 3 of 9
---------------------------	--------------	------	------------------------------	---------------------------------------	------------------	-----------------

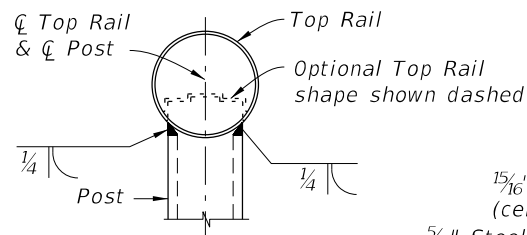

SECTION A-A
(Top Rail Connection)

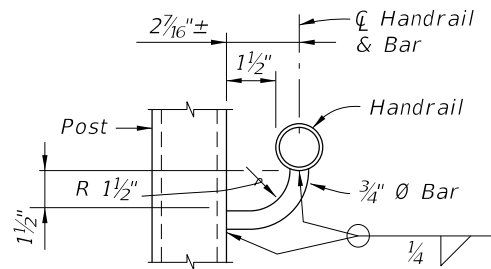

SECTION B-B
(Handrail Connection)

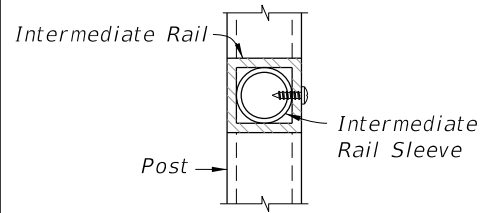

SECTION C-C
(Intermediate Rail Connection)

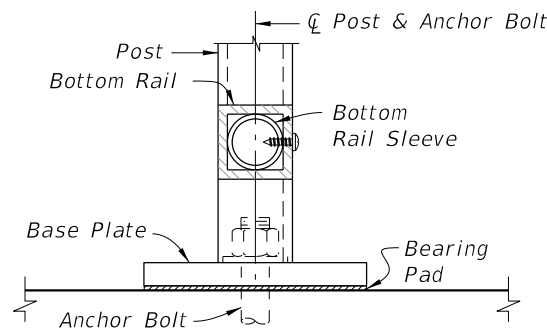

SECTION D-D
(Bottom Rail Connection -
Single Anchor Bolt Shown)

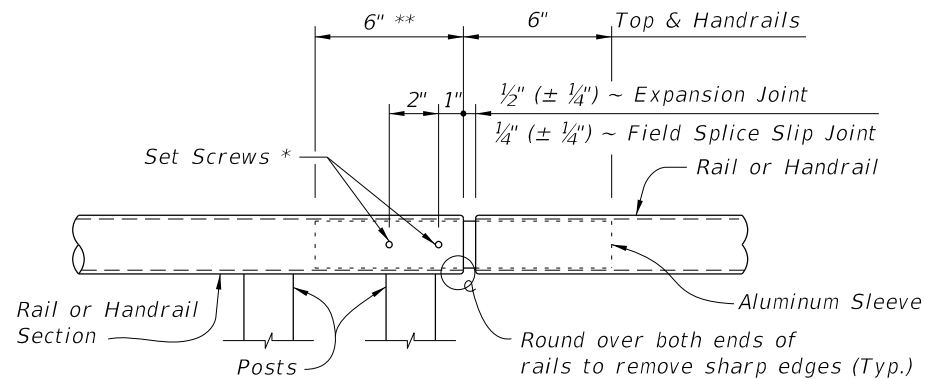

ROUND RAILS - TOP RAIL OR HANDRAIL
(Top Rail at Expansion Joint Shown)

DETAIL "B" - EXPANSION JOINT (FIELD SPLICE SLIP JOINT SIMILAR)

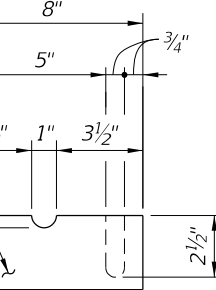

SHIM PLATE DETAIL

**PLATE WASHER
DETAIL**

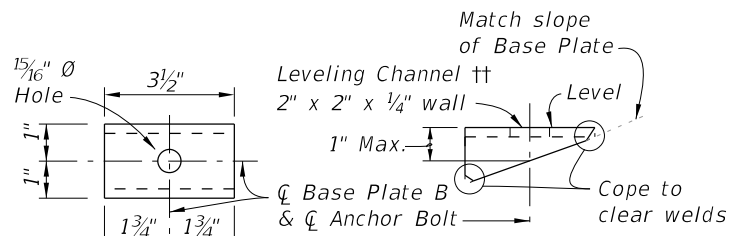

TOP VIEW

SIDE VIEW

LEVELING CHANNEL DETAIL

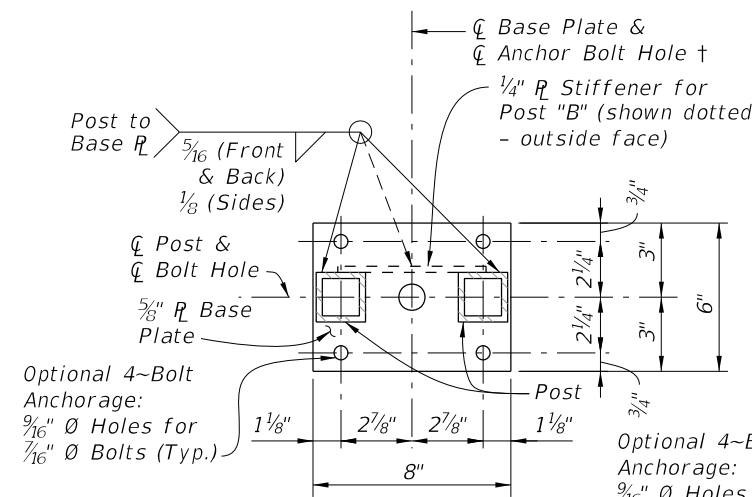

BASE PLATE A

BASE PLATE B

SECTION G-G - BASE PLATE DETAILS

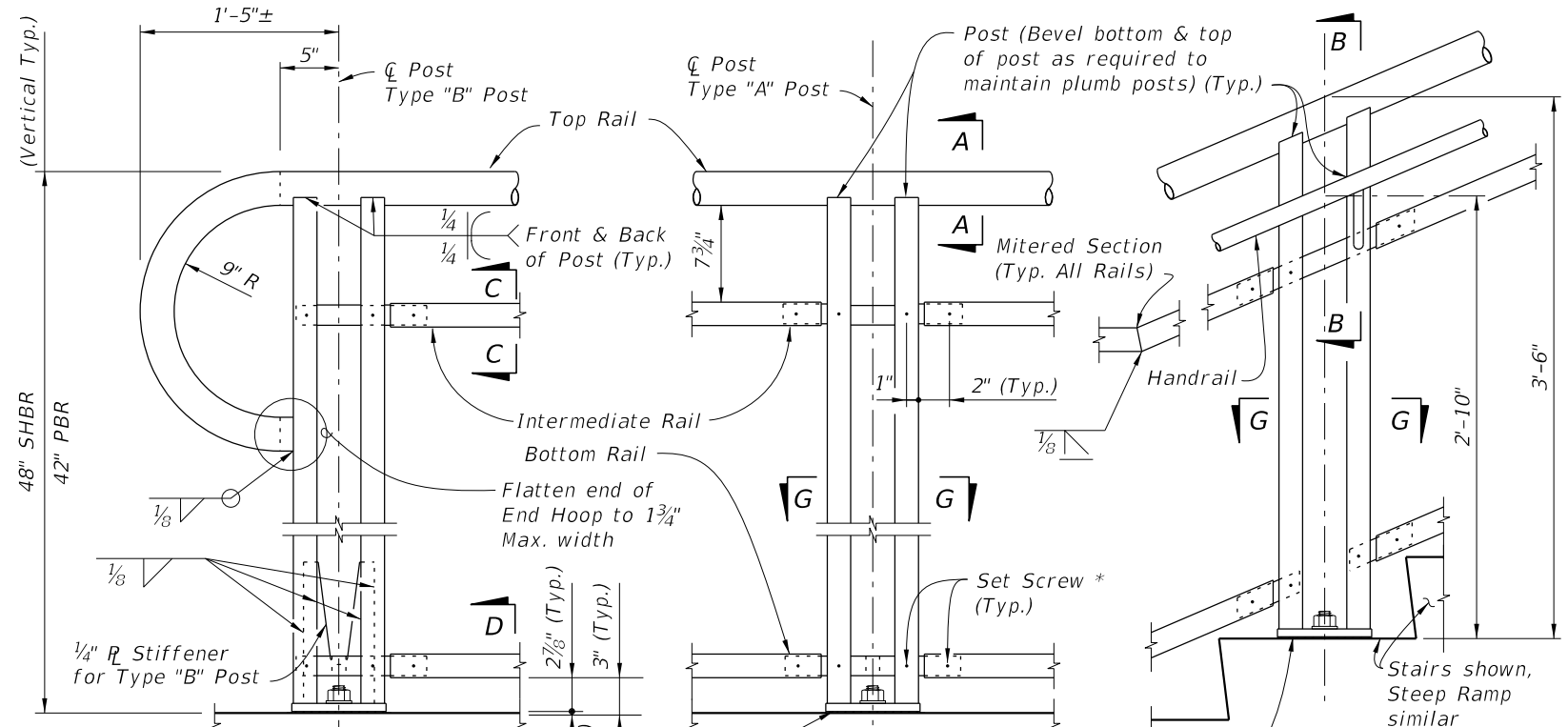

DETAIL "A" - RAIL CONNECTIONS
(Showing Inside Face of Railing)
(Pickets/Panels and 4~Bolt Anchorage Not Shown for Clarity)

NOTES:

† Base Plate A (Ramps - Bolts normal) use 1 1/16 inch diameter holes for single anchor bolts with flat washers for slopes less than or equal to 8.33%.

‡ Base Plate B (Stairs - Bolts plumb) use 1/4 inch diameter holes for single anchor bolts with beveled plate and washers for slopes greater than 8.33% to less than or equal to 15%; use 1 5/16 inch x 1 1/2 inch slotted holes with leveling channel for slopes greater than 15%.

* 1/4 inch diameter x 3/4 inch pan head aluminum or stainless steel set screws. Screws must be set flush against the outside face of rails & posts and underside of handrails. A single tack weld (1/2 inch max. length) at top of the sleeve for each post may be substituted for the set screws. Do not provide set screws for rails at free end of expansion joints.

** Embedded length may be 4 inches for plug welded connection.

**POST "B" STIFFENER
DETAIL**

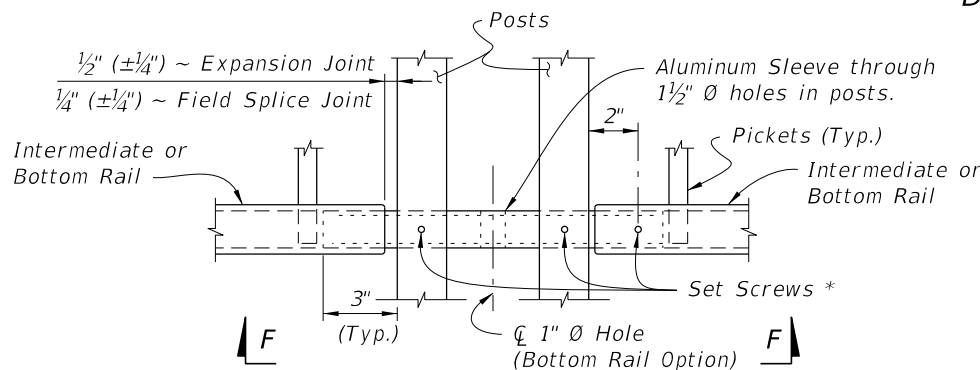

SQUARE RAILS - INTERMEDIATE OR BOTTOM RAIL
(Bottom Rail Shown at Expansion Joint Shown)

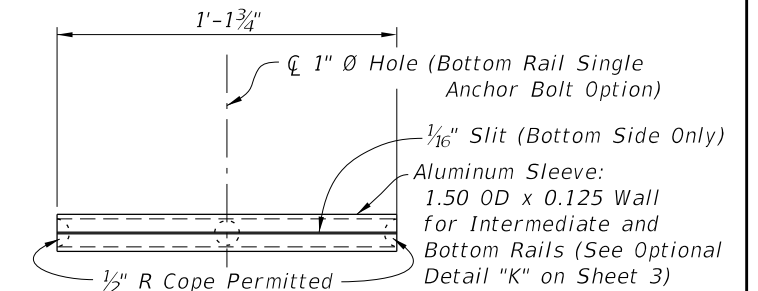

VIEW F-F
INTERMEDIATE OR BOTTOM RAIL -
ALUMINUM SLEEVE DETAIL (Bottom Side Shown)

CROSS REFERENCE:

For location of Details "B", See Sheet 2.

10/20/2022 8:50:23 AM

LAST REVISION	DESCRIPTION:
11/01/16	



FY 2023-24
STANDARD PLANS

PEDESTRIAN/BICYCLE RAILING (ALUMINUM)

INDEX
515-062

SHEET
4 of 9

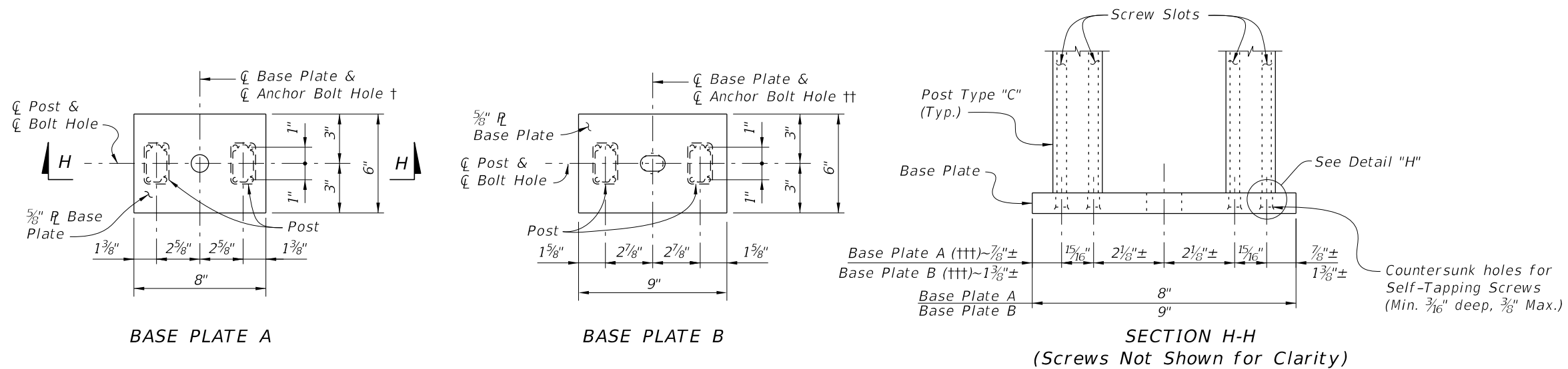

BASE PLATE DETAILS FOR TYPE "C" POST

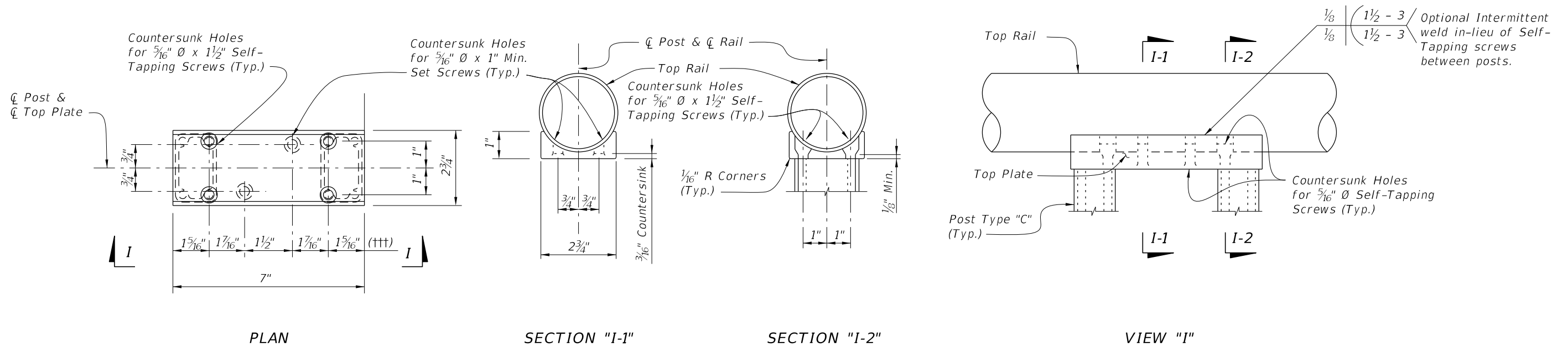

TOP PLATE DETAILS FOR TYPE "C" POST
(Screws Not Shown For Clarity)

Notes:
 † See Sheet 4 for Notes.
 †† See Sheet 4 for Notes.
 ††† Length varies for beveled posts on grades. Holes must be drilled plumb to align with screw slot.

12/13/2022 8:30:17 AM

LAST REVISION 11/01/16	REVISION	DESCRIPTION:		FY 2023-24 STANDARD PLANS	PEDESTRIAN/BICYCLE RAILING (ALUMINUM)	INDEX 515-062	SHEET 5 of 9
---------------------------	----------	--------------	---	------------------------------	---------------------------------------	------------------	-----------------

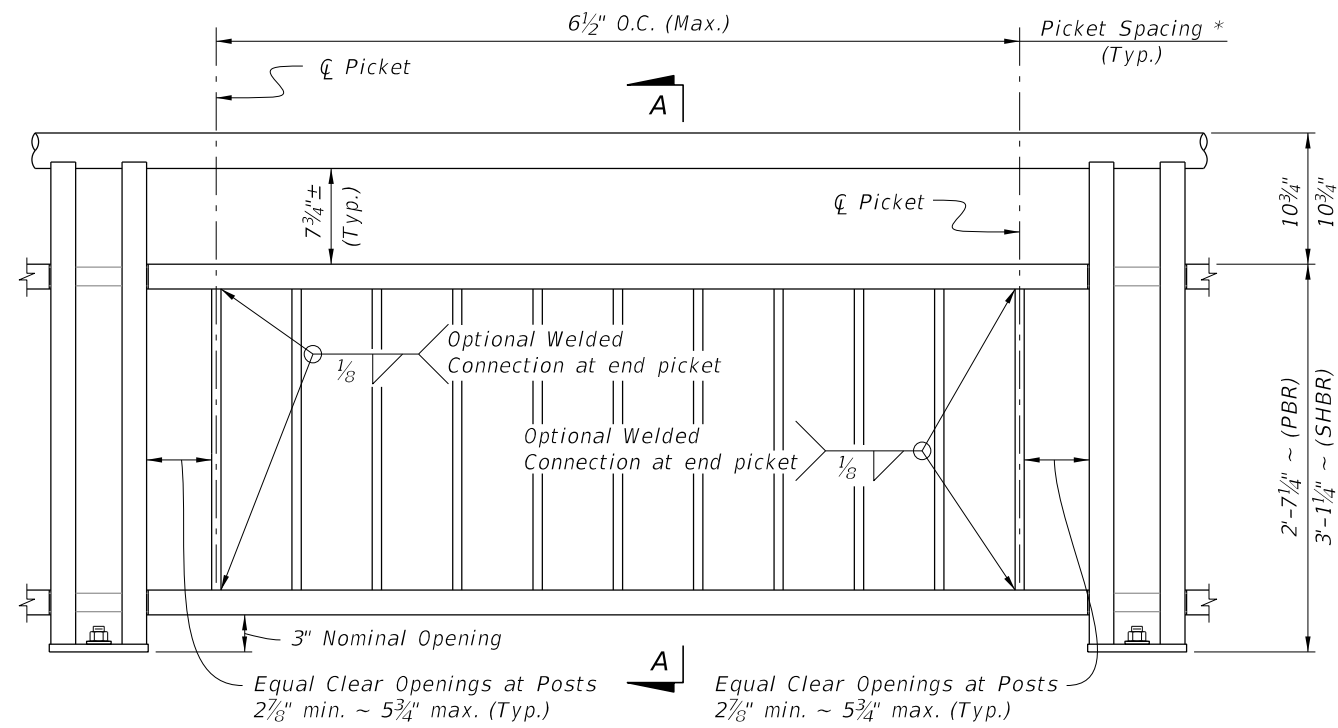

TYPE 1 - PICKET INFILL PANEL

PICKET NOTES:

* Picket Spacing of 6 1/2" centers is based on a 3/4" Ø Bar for standard applications. When shown in the Contract Plans a 4 1/2" picket spacing may be required. See Note 4 (Sheet 1).

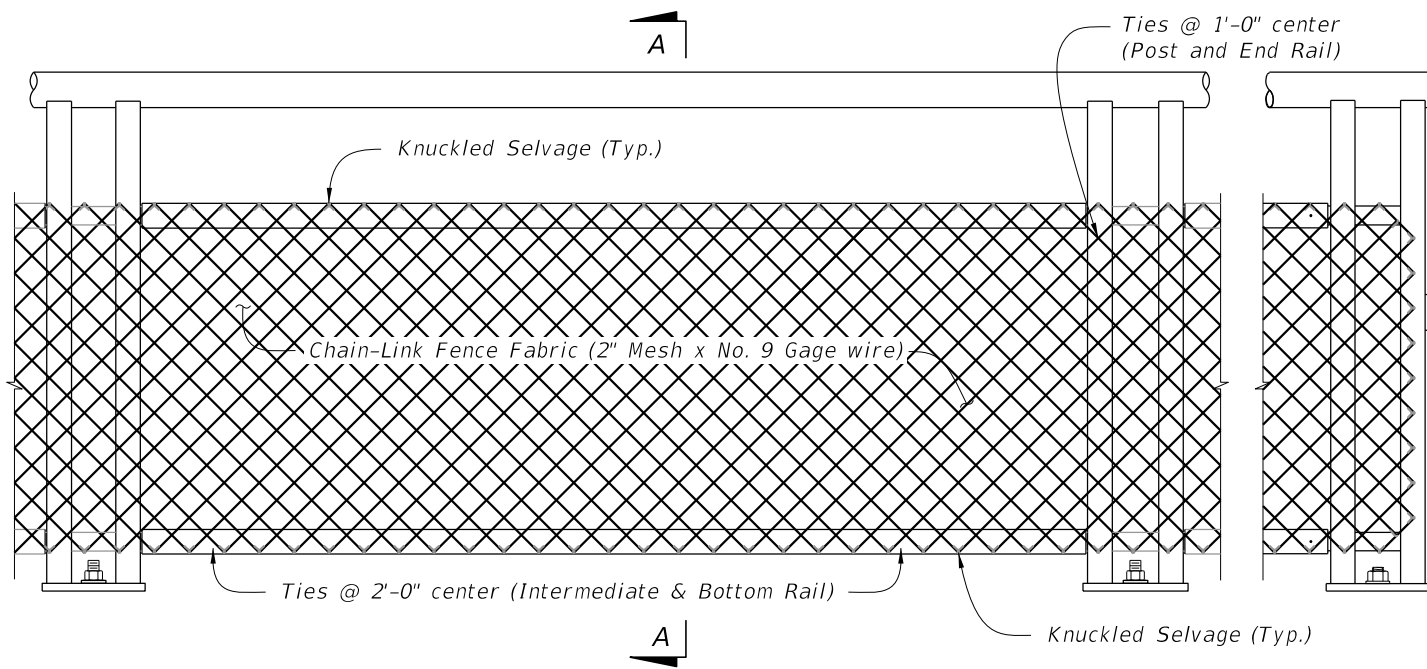

TYPE 2 - CHAIN-LINK (Continuous Infill Panel)

NOTE:

See Plans for Infill Panel option required.

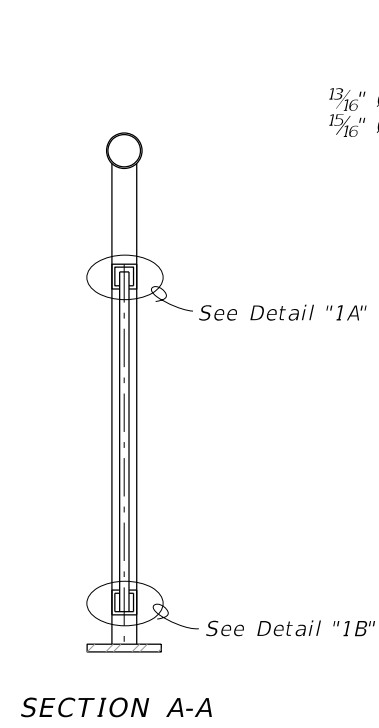

SECTION A-A

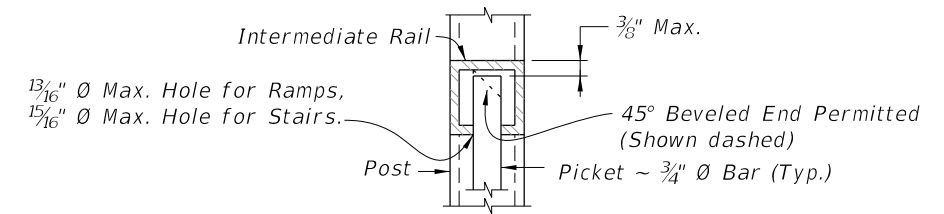

**DETAIL "1A"
(Top of Picket Connection)**

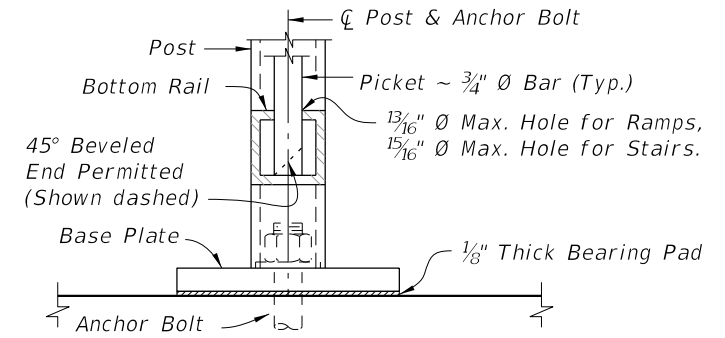

**DETAIL "1B"
(Bottom of Picket Connection)**

TABLE 2 - CHAIN-LINK PANEL COMPONENT MATERIALS		
COMPONENT	ASTM	COMPONENT INFORMATION
Chain-Link Fence Fabric (2" mesh with knuckled top and bottom selvage)	A392	Zinc-Coated Steel - No. 9 gage (coated wire diameter), Class 2 Coating
	A491	Aluminum-Coated Steel - No. 9 gage (coated wire diameter)
	F668	Polyvinyl Chloride (PVC) Coated Steel - No. 9 gage Zinc-Coated Wire (metallic-coated core wire diameter) ~ See Plans for specified color of PVC.
Tie Wires	F626	Zinc-Coated Steel Wire - No. 9 gage with coating to match Chain-Link Fence Fabric.
Tension Bars	F626	3/16" (min. thickness) x 3/4" (min. width) x 2'-3" (min. height) Steel Bars
Miscellaneous Fence Components	F626	Zinc-Coated Steel

CHAIN-LINK PANEL NOTE:

Chain-Link Fence Fabric shall be continuous along limits of railing. Splicing of Chain-Link panels using Tension Bars at 20'-0" minimum increments is permitted.

10/20/2022 8:50:25 AM

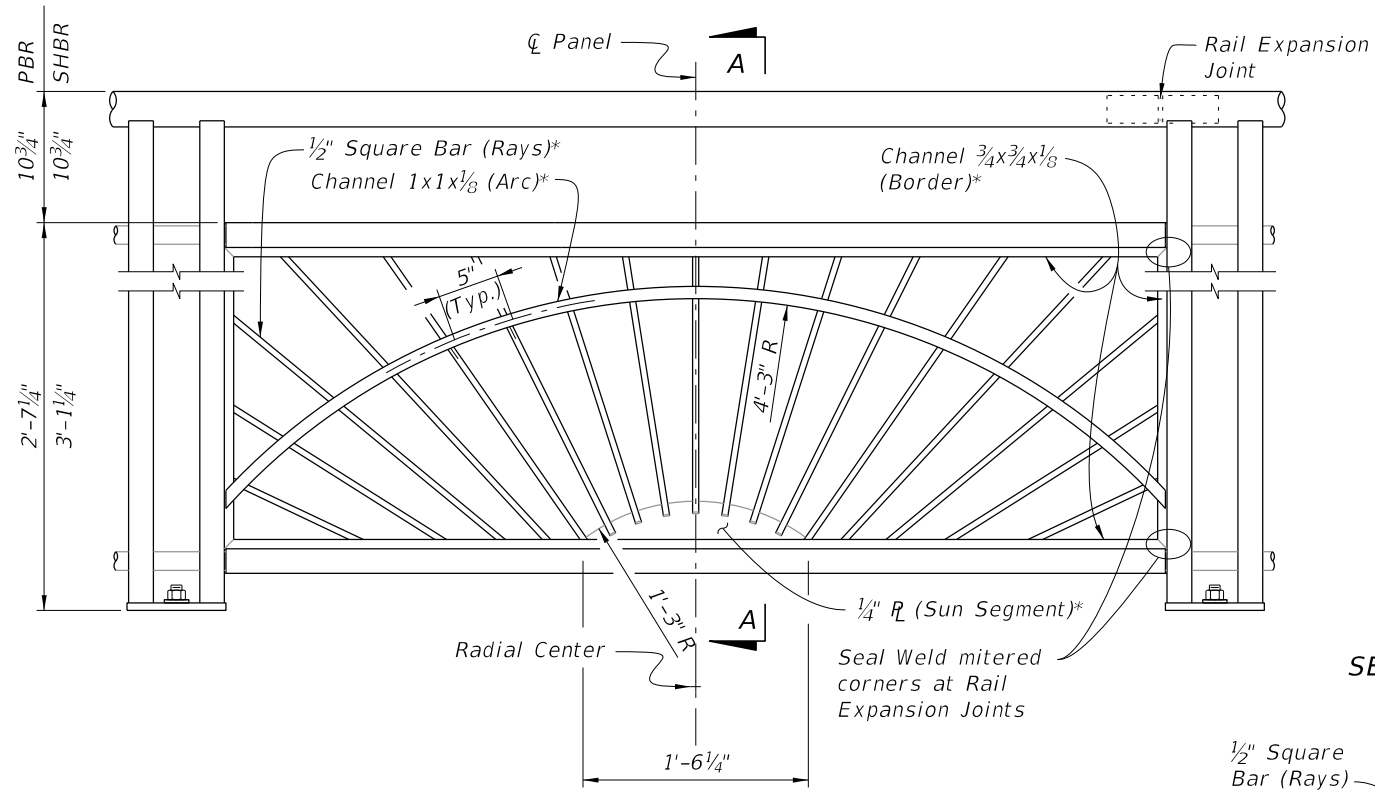

TYPE 3 - SUNSHINE INFILL PANEL

* Arc, Rays and Sun Segment may be formed in a single panel from 1/2" plate (ASTM B209 Alloy 6061-T6 or T651) pattern cut with laser or plasma CNC, welded to a 1x1x1/8 Angle Border or the 3/4x3/4x1/8 Channel Border shown.

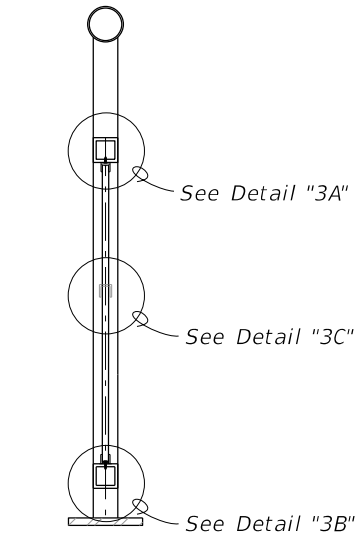

SECTION A-A

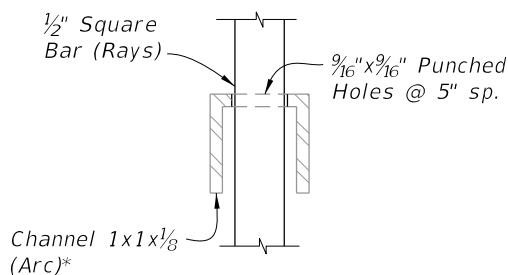

DETAIL "3C" RAY/ARC CONNECTION

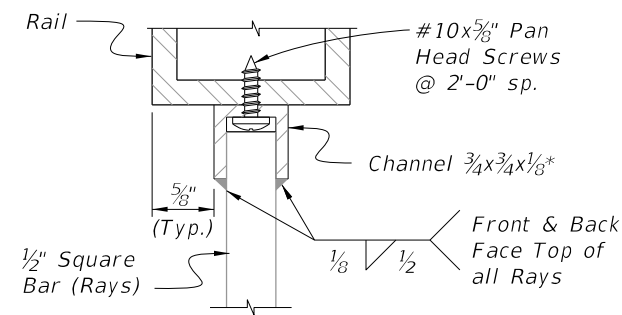

DETAIL "3A" INTERMEDIATE RAIL/RAY CONNECTION

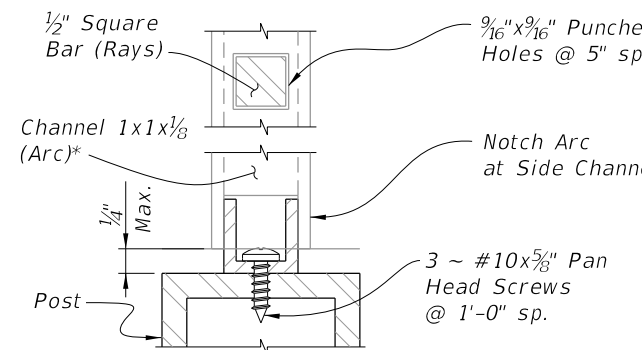

DETAIL "3D" ARC/POST CONNECTION (Continuous Top Rail)

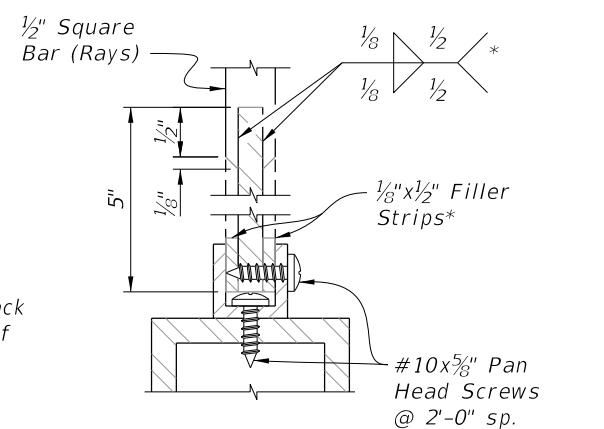

DETAIL "3B" BOTTOM RAIL/RAY CONNECTION

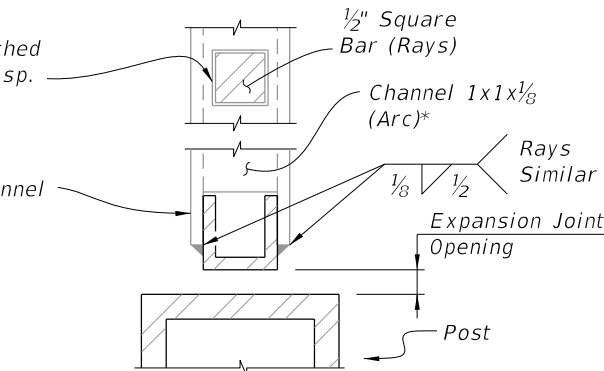

DETAIL "3E" PANEL END CONNECTION AT POST WITH EXPANSION JOINT

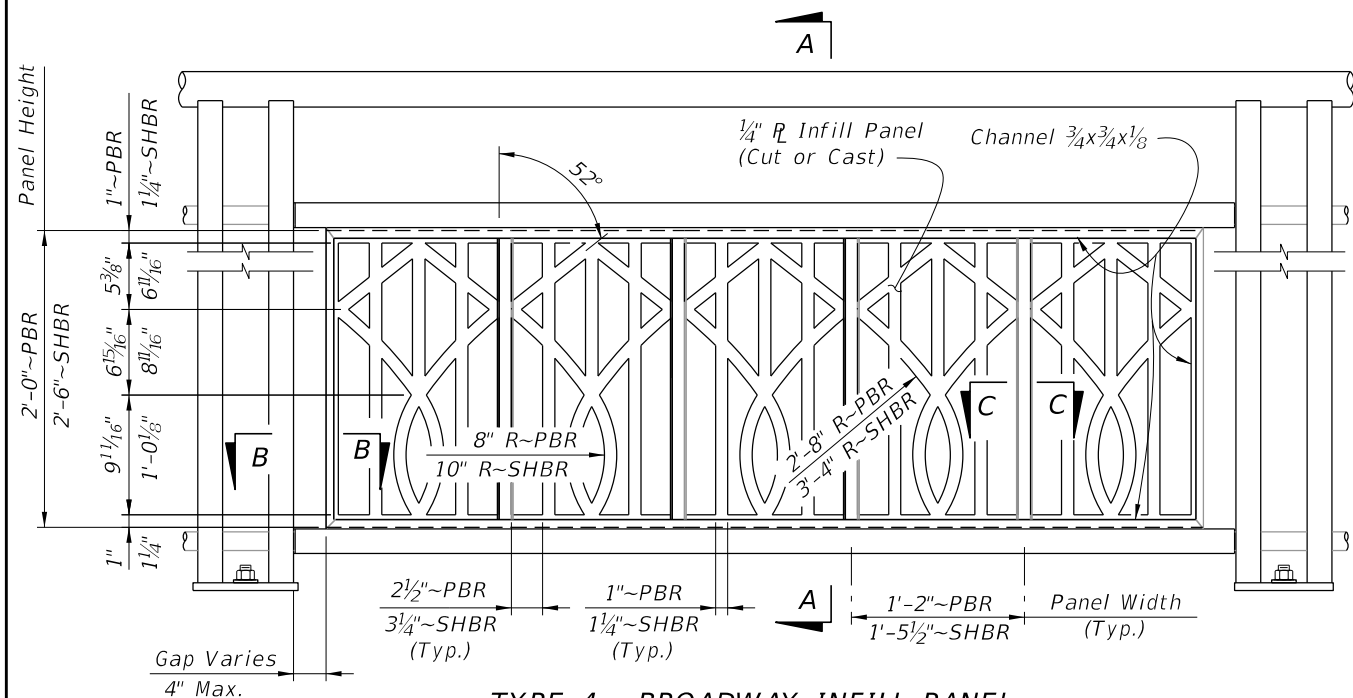

TYPE 4 - BROADWAY INFILL PANEL

NOTE: See Plans for Infill Panel Option required.

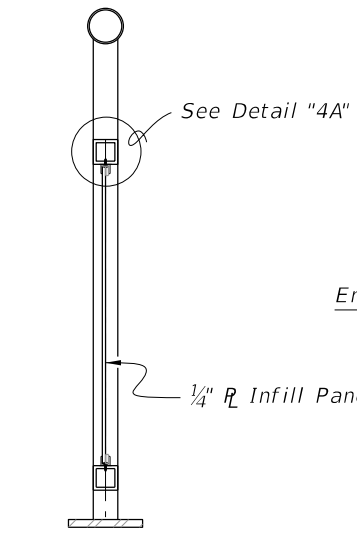

SECTION A-A

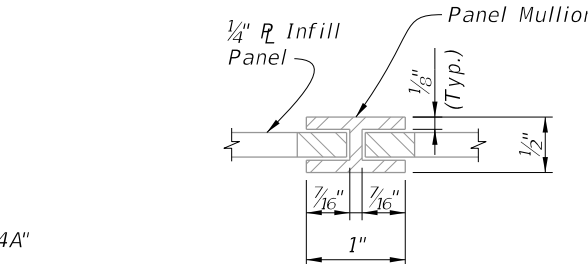

SECTION C-C PANEL/SPLICE CONNECTION

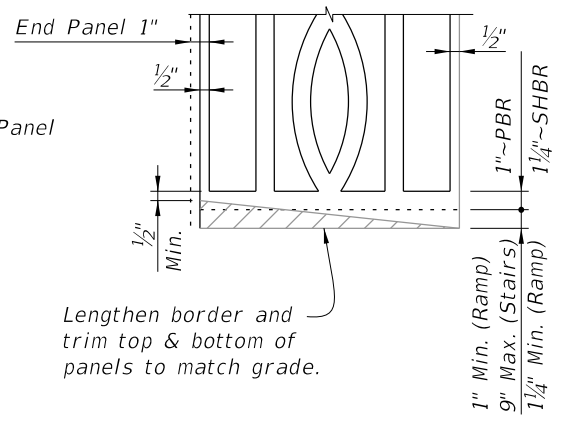

PANEL ADJUSTMENT FOR RAILINGS ON GRADES

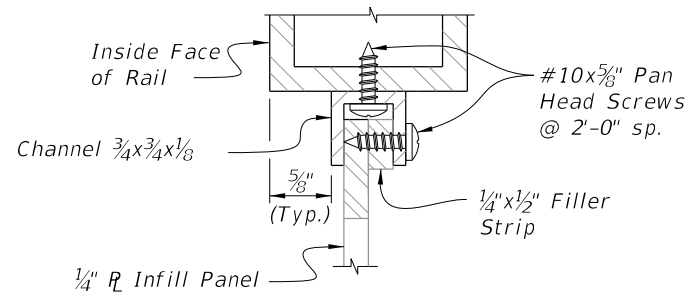

DETAIL "4A" PANEL/RAIL CONNECTION (Top Shown, Bottom Similar)

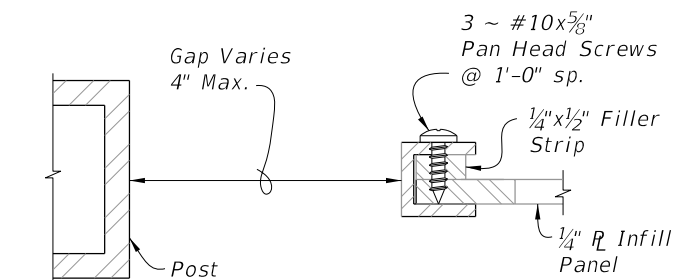

SECTION B-B PANEL END CAP

10/20/2022 8:50:26 AM

LAST REVISION 11/01/16	DESCRIPTION:		FY 2023-24 STANDARD PLANS	PEDESTRIAN/BICYCLE RAILING (ALUMINUM)	INDEX 515-062	SHEET 7 of 9

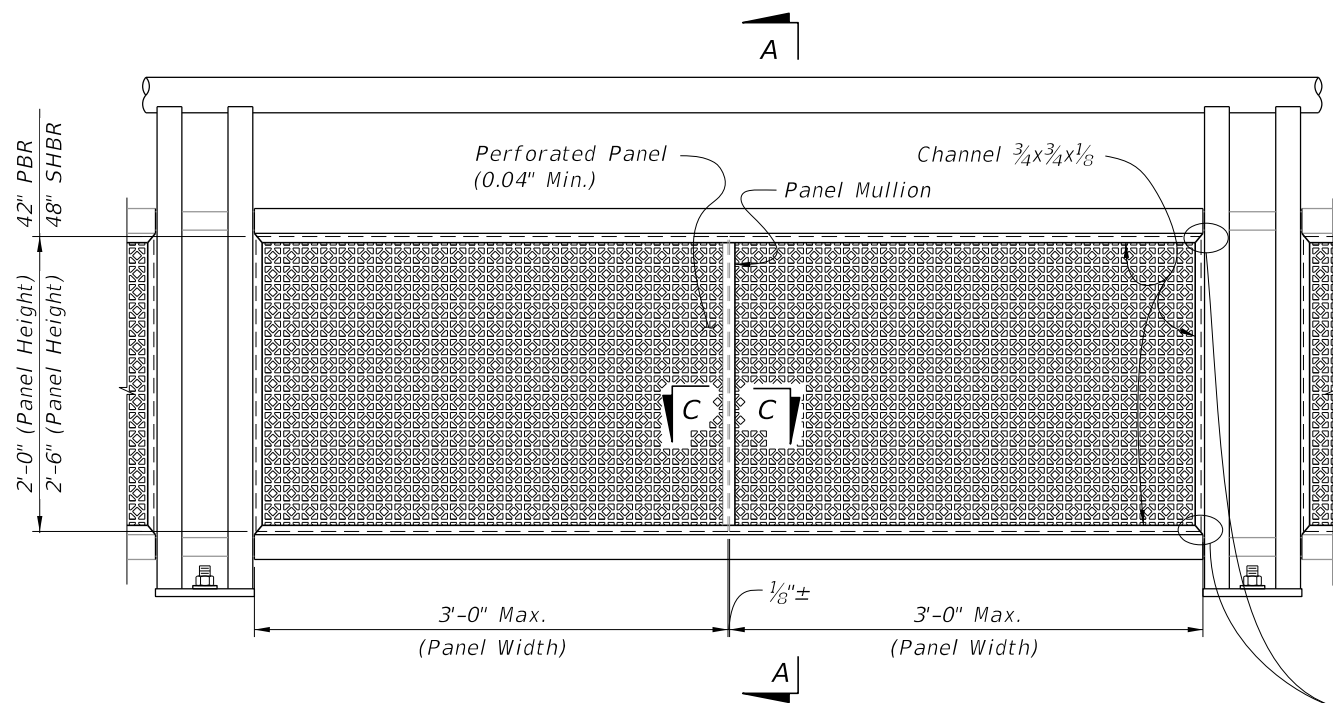

TYPE 5 - PERFORATED INFILL PANEL

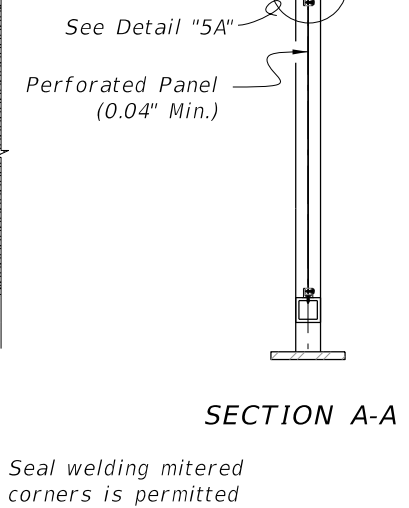

SECTION A-A

Seal welding mitered corners is permitted

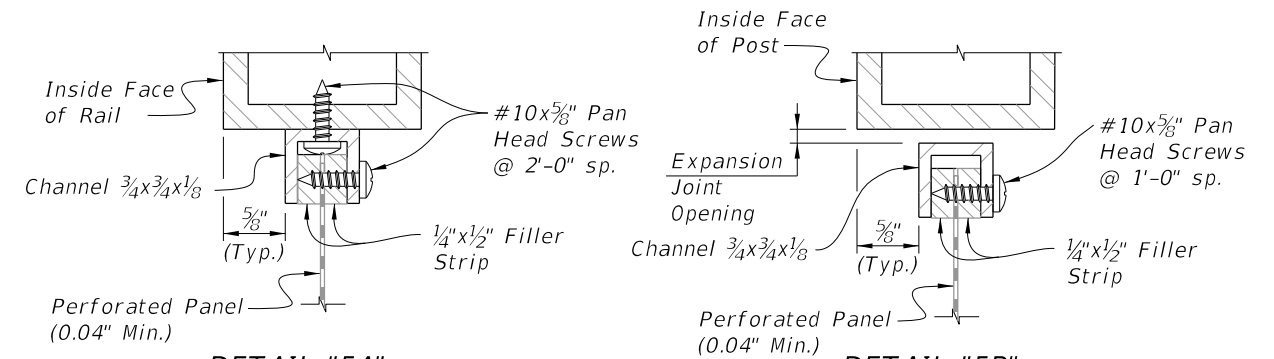

DETAIL "5A"
PANEL/RAIL CONNECTION
(Top Shown, Bottom Similar)

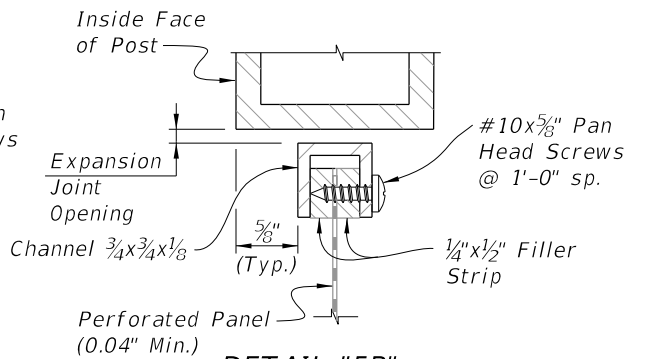

DETAIL "5B"
PANEL END CONNECTION
(Expansion Joint Shown, Sides Similar)

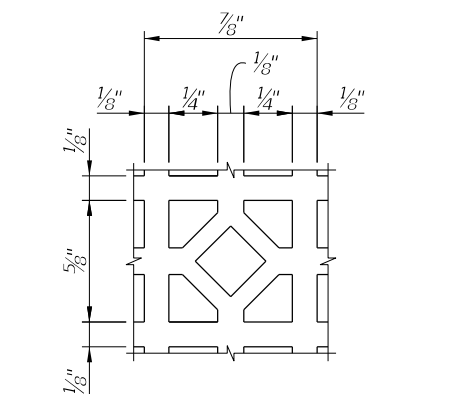

REPEATING PATTERN DETAIL
FOR PERFORATED PANEL

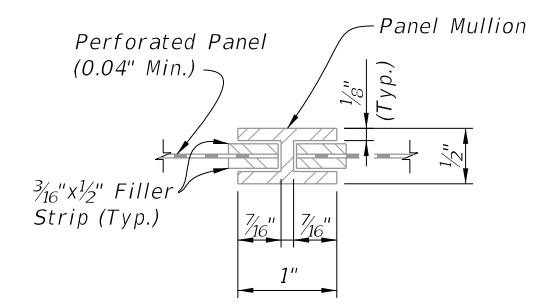

SECTION C-C
PANEL/SPLICE CONNECTION

10/20/2022 8:50:27 AM

LAST REVISION 11/01/16	REVISION	DESCRIPTION:		FY 2023-24 STANDARD PLANS	PEDESTRIAN/BICYCLE RAILING (ALUMINUM)	INDEX 515-062	SHEET 8 of 9
---------------------------	----------	--------------	--	------------------------------	---------------------------------------	------------------	-----------------

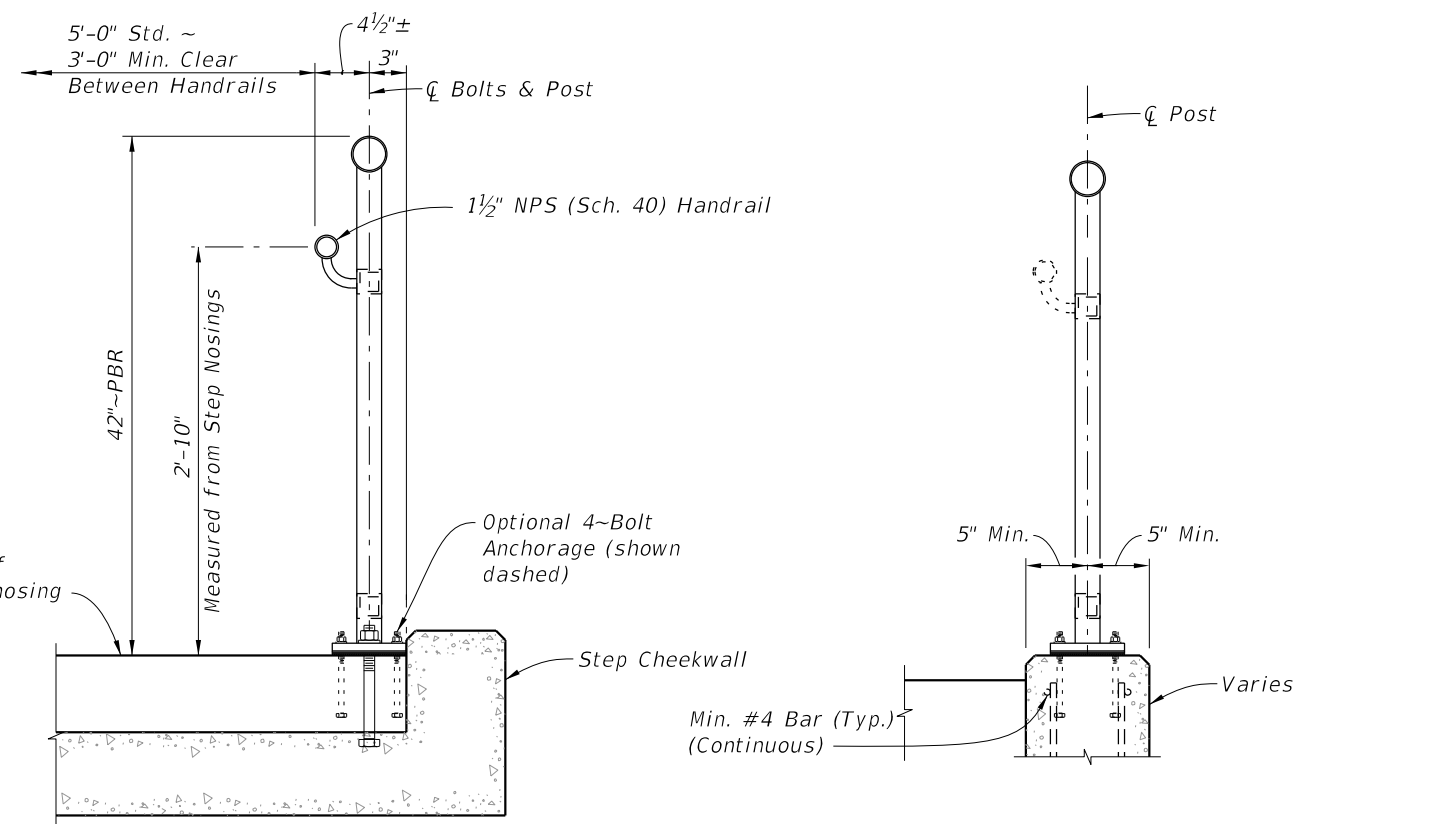
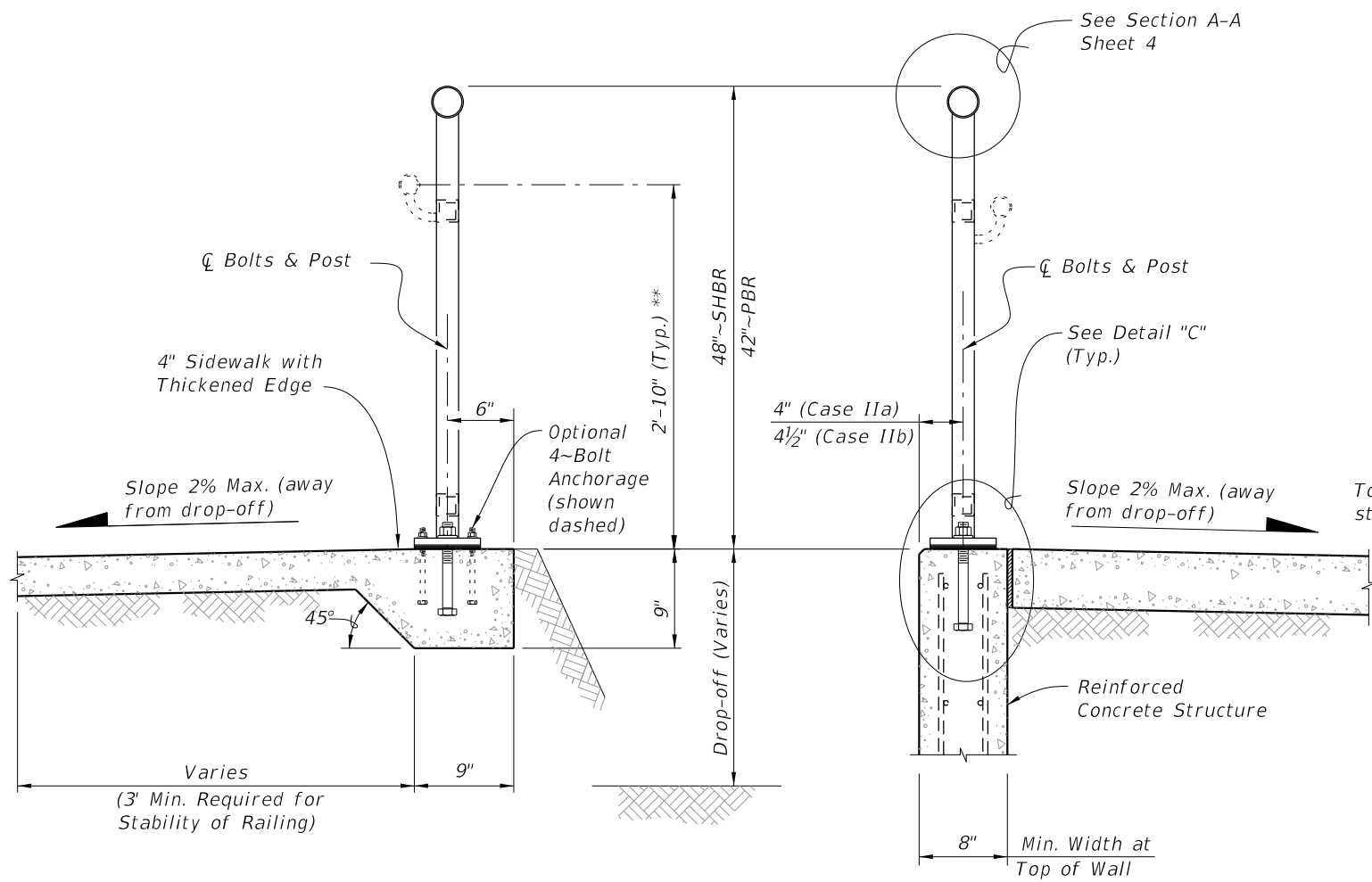

TYPICAL SECTION ON CONCRETE SIDEWALK (Case I)

TYPICAL SECTION ON RETAINING WALL (Case II)

TYPICAL SECTION ON STEPS & STAIRS (Case III)

TYPICAL SECTION FOR 4~BOLT ANCHORAGE (Case IV)

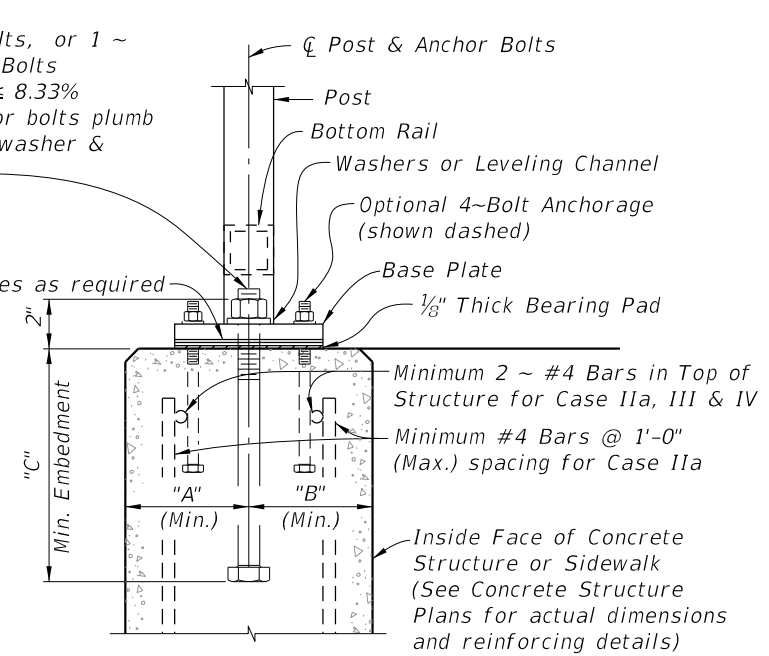
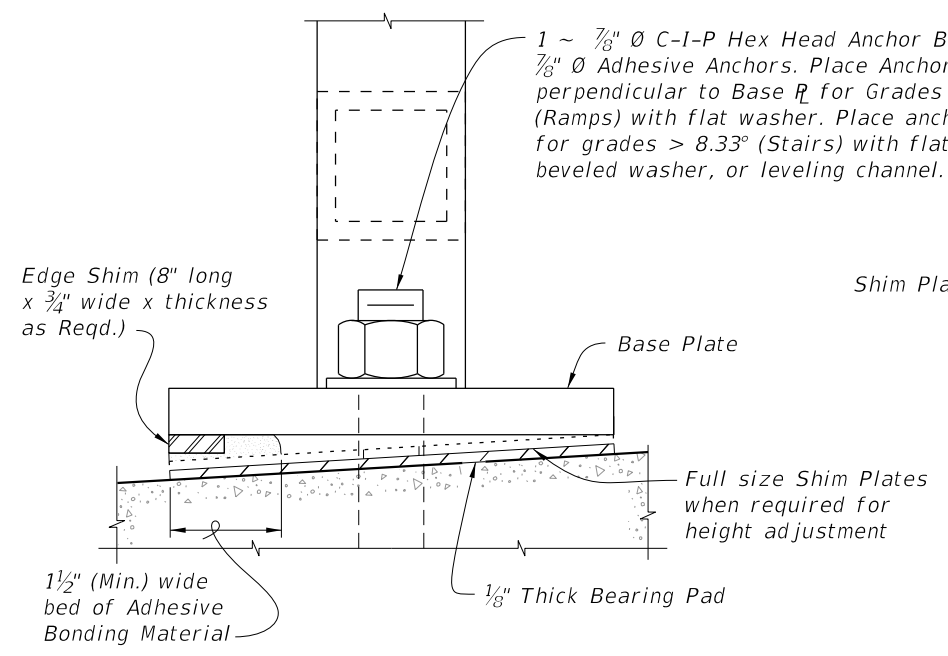

CASE	STRUCTURE TYPE	DIMENSIONS			ANCHOR LENGTH		ANCHOR SIZE
		"A" Edge Dist.	"B" Edge Dist.	"C" Embedment	C.I.P Hex Head Bolt	Adhesive Anchor	
		I	Unreinforced Concrete	6"	1'-2"	6"	
IIa	Reinforced Concrete	4"	4"	9"	10 1/2"	11"	7/8" Ø
IIb	Gravity Wall Index 400-011	4 1/2"	3 1/2" @ top	9"	10 1/2"	11"	7/8" Ø
III	Step Cheekwall	4 1/2"	4 1/2"	9"	10 1/2"	11"	7/8" Ø
IV	Varies	5"	5"	5"	6 1/2"	7"	7/16" Ø

** When required; measured from top of sidewalk (Typ.)

10/20/2022 8:50:29 AM

NOTES:

1. Shop Drawings are required.
2. Work with Specification 515.
3. Materials:
 - A. Pan Head Set Screws: Aluminum Alloy 2024-74 or 7075-T73 or Stainless Steel (SS) Type 316 or 18-8 Alloy.
 - B. Base Plates and Cap Plates: ASTM B209, Alloy 6061-T6
 - C. Structural Pipe Tube and Bars: ASTM B221 or ASTM B429, Alloy 6061-T6
 - D. End Rails 90° bends and corner bends with a maximum 4 foot spacing; Alloy 6063-T5 is permitted.

RAILING MEMBER DIMENSIONS TABLE			
MEMBER	DESIGNATION	OUTSIDE DIMENSION	WALL THICKNESS
Posts	2" NPS (Sch. 40)	2.375"	0.154"
Rails	2" NPS (Sch. 40)	2.375"	0.154"
Rail Joint/Splice Sleeves	1½" NPS (Sch. 40)	1.900"	0.145"
Handrails Joint/Splice Sleeves	1" NPS (Sch. 40) 1.50 ODx0.125 Wall	1.315" 1.500"	0.133" 0.125"
Handrails	1½" NPS (Sch. 40)	1.900"	0.145"
Handrail Support Bar	1" Ø Round Bar	1.000"	N/A

- E. Galvanized Steel Fasteners:
 - a. Hex Head Bolts: ASTM A 307 Type 1 or ASTM F1554 Grade 36
 - b. Adhesive Anchors: ASTM F1554 Grade 36 fully threaded rods
 - c. Hex Nuts: ASTM A563
 - d. Flat Washers: ASTM F436
 - F. Aluminum Shims: ASTM B209, Alloy 6061
 - G. Bearing Pads: Plain, Fabric Reinforced, or Fabric Laminated meeting requirements of Specifications 515 & 932.
4. Fabrication:
 - A. Place expansion joints at a maximum of 30'-0" spacing
 - B. Field splices are similar to the expansion joint detail and may be approved by the Engineer to facilitate handling; but top rail must be continuous across a minimum of two posts.
 - C. Continuity field splice (Detail "E"); only use to make the railing continuous for unforeseen field adjustments
 - D. Corners and changes in tangential longitudinal alignment may be made continuous with a 9" bend radius or terminated at adjoining sections with a standard end hoop when handrails are not required.
 - E. For curved longitudinal alignments, shop bend top and bottom rails and handrails to match the alignment radius.
 - F. For changes in tangential longitudinal alignment greater than 45°, position posts a maximum of 2'-0" each side of the corner, not at the corner apex.
5. Handrails are required and must be continuous at landings for:
 - A. Grades Steeper than 5%
 - B. Three or more steps
6. Cutting of reinforcing steel is permitted for post installed anchor bolts.

10/20/2022 8:50:29 AM

LAST REVISION 11/01/18	REVISION	DESCRIPTION:	 FY 2023-24 STANDARD PLANS	PIPE GUIDERAIL (ALUMINUM)	INDEX 515-070	SHEET 1 of 5
---------------------------	----------	--------------	---	----------------------------------	-------------------------	------------------------

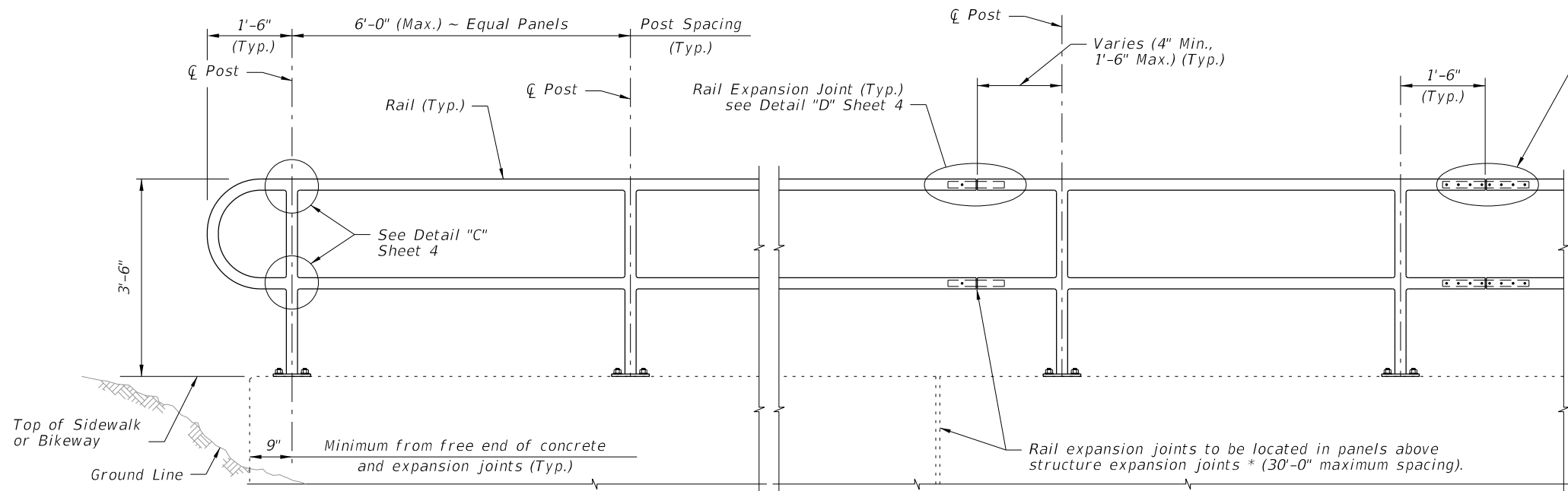

NOTES:
 NPS = Nominal Pipe Size
 STRUCTURES EXPANSION JOINTS NOTE:
 * Keyed construction joints in Index 400-011 Gravity Wall are not considered to be expansion joints.

CROSS REFERENCE:
 For Details "C", "D" and "E", see Sheet 4.

ELEVATION

TYPICAL RAILING DETAILS & RAILINGS ON GRADES 0% TO 5%

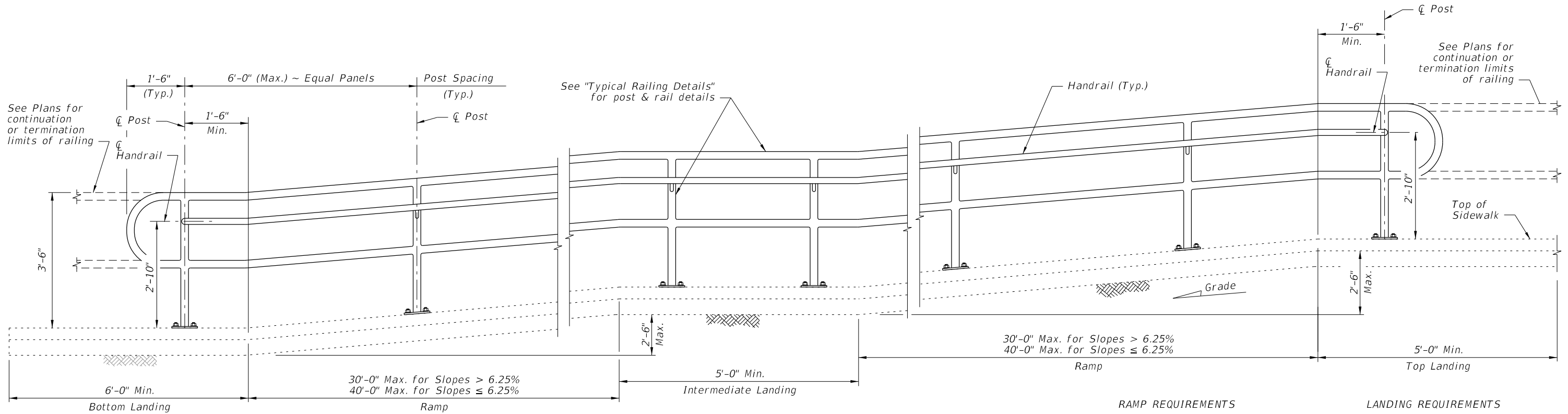

RAMP REQUIREMENTS

For slopes greater than 5%:
 Max. ramp slope = 8.33%
 Max. ramp cross-slope = 2.0%

LANDING REQUIREMENTS

Max. landing slope = 2%
 Max. landing cross-slope = 2%

ELEVATION
 (Showing Inside Face of Railing)

RAILINGS ON GRADES STEEPER THAN 5% TO 8.33%

10/20/2022 8:50:30 AM

LAST REVISION 11/01/17	REVISION	DESCRIPTION:		FY 2023-24 STANDARD PLANS	PIPE GUIDERAIL (ALUMINUM)	INDEX 515-070	SHEET 2 of 5
---------------------------	----------	--------------	--	------------------------------	---------------------------	------------------	-----------------

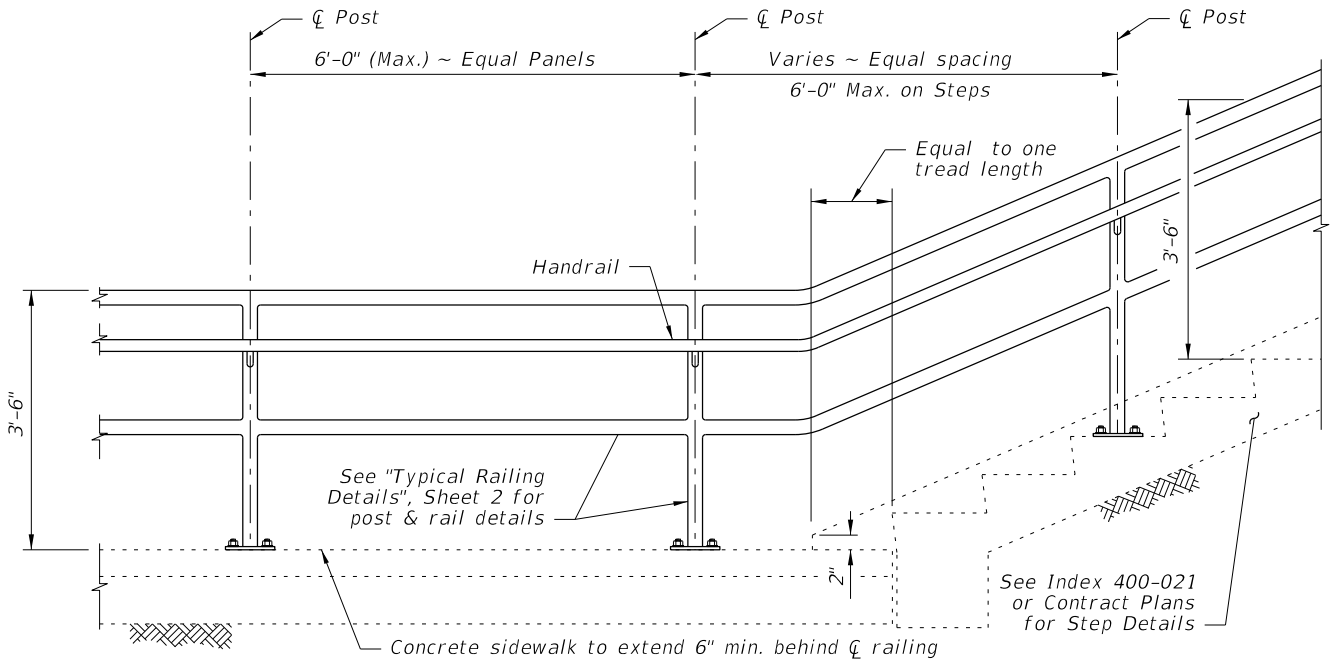

RAILING CONTINUATION BEYOND STEPS
(Bottom shown, Top similar)

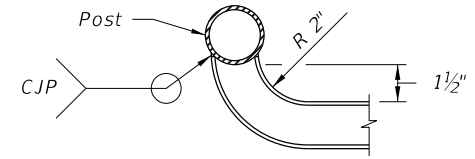

DETAIL "A" - PLAN VIEW
HANDRAIL TERMINATION

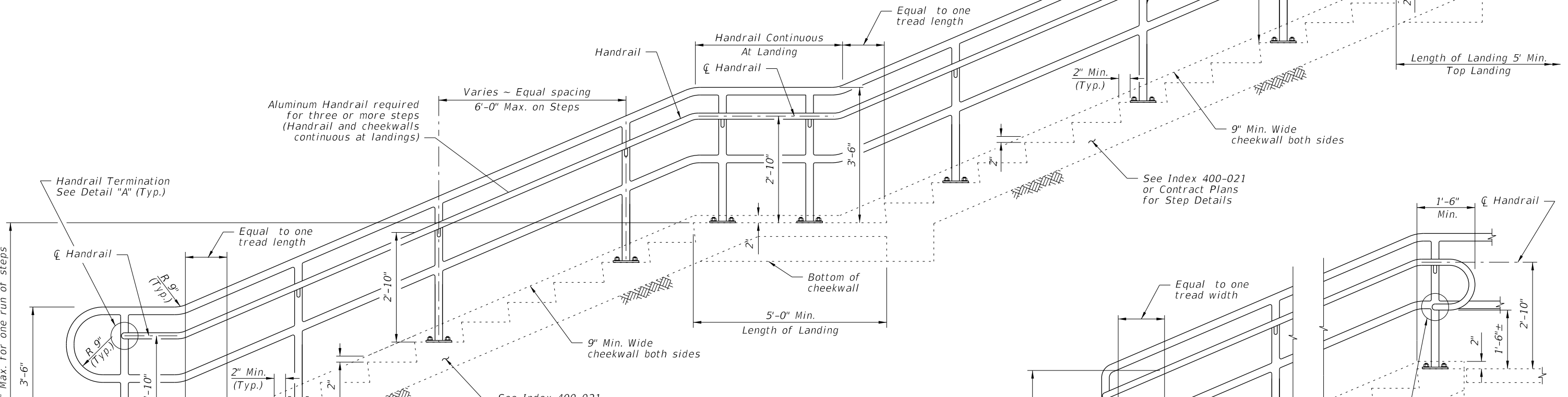

ELEVATION
(At-Grade Steps)

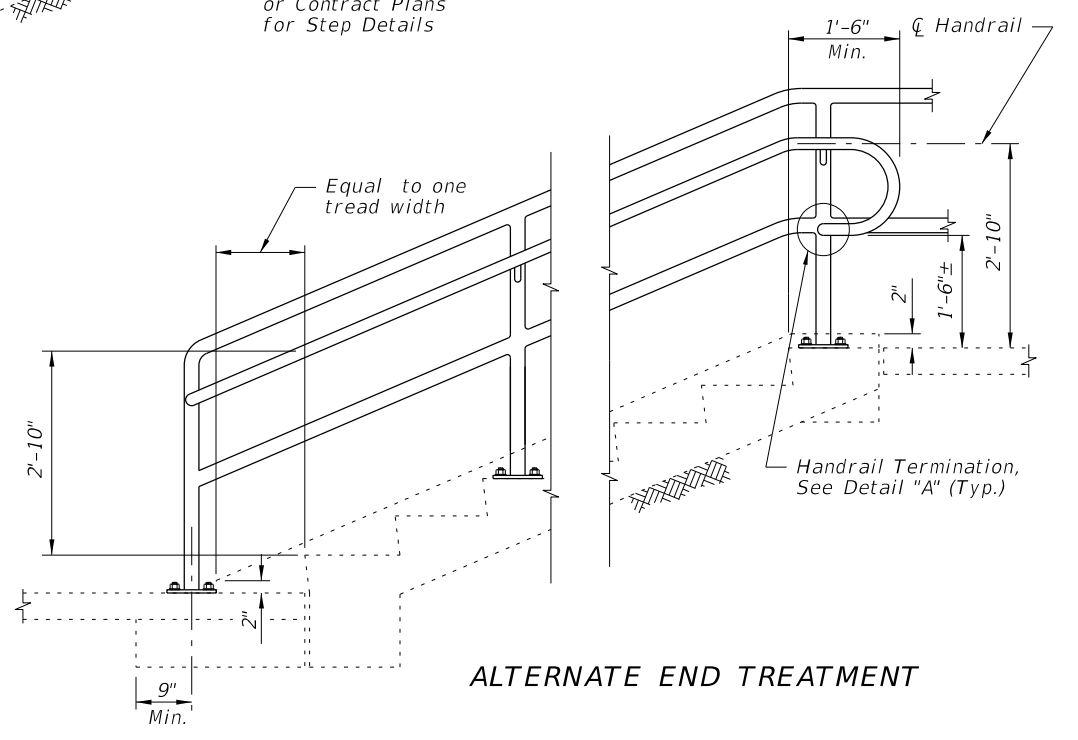

ALTERNATE END TREATMENT

GUIDERAIL ON STEPS & STAIRS

10/20/2022 8:50:31 AM

LAST REVISION 11/01/17	REVISION	DESCRIPTION:		FY 2023-24 STANDARD PLANS	PIPE GUIDERAIL (ALUMINUM)	INDEX 515-070	SHEET 3 of 5
---------------------------	----------	--------------	--	------------------------------	---------------------------	------------------	-----------------

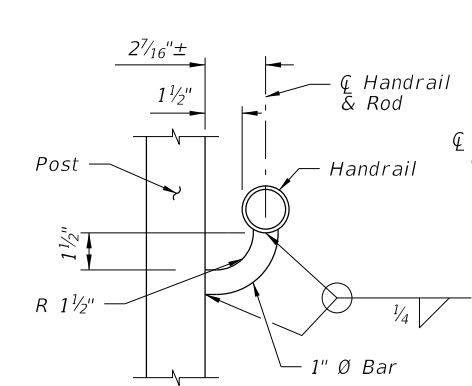

SECTION B-B
(Handrail Connection)

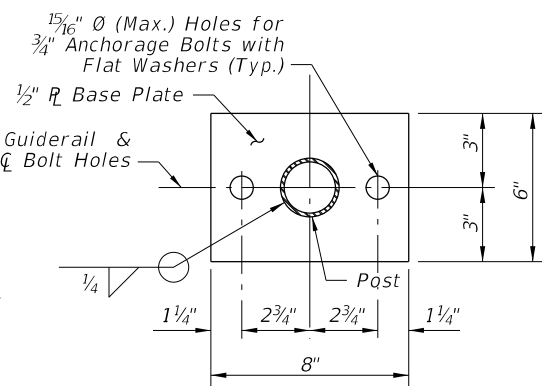

SECTION C-C
BASE PLATE DETAIL
(2~Bolt Anchorage)

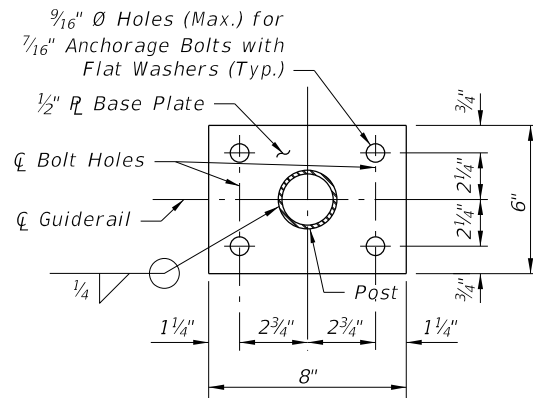

SECTION C-C
BASE PLATE DETAIL
(4~Bolt Anchorage)

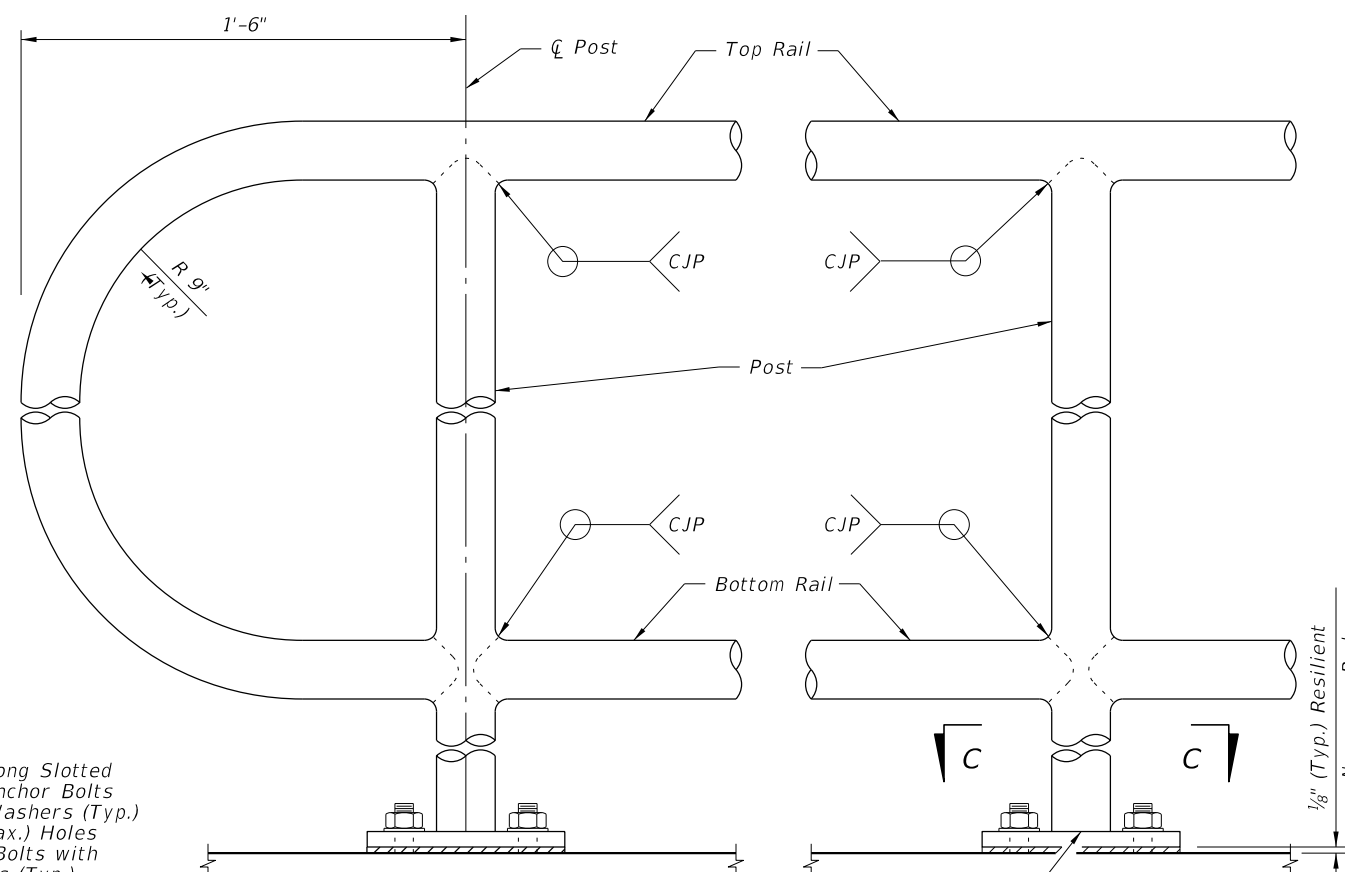

DETAIL "C" - RAIL CONNECTIONS
(Handrail and 4~Bolt Anchorage Not Shown)

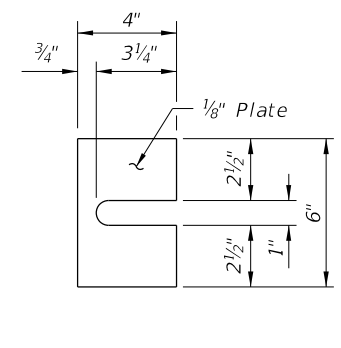

SHIM PLATE DETAIL
(2~Bolt Anchorage)

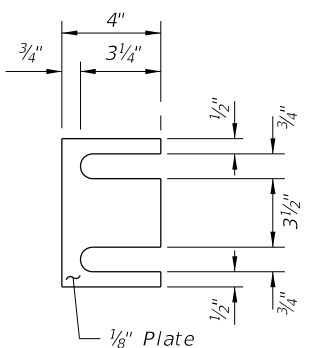

SHIM PLATE DETAIL
(4~Bolt Anchorage)

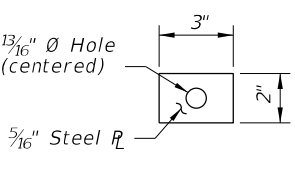
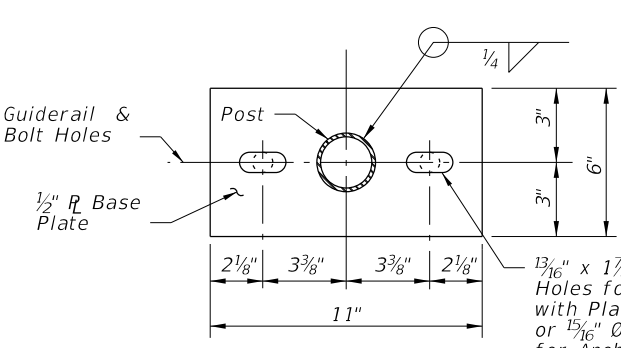
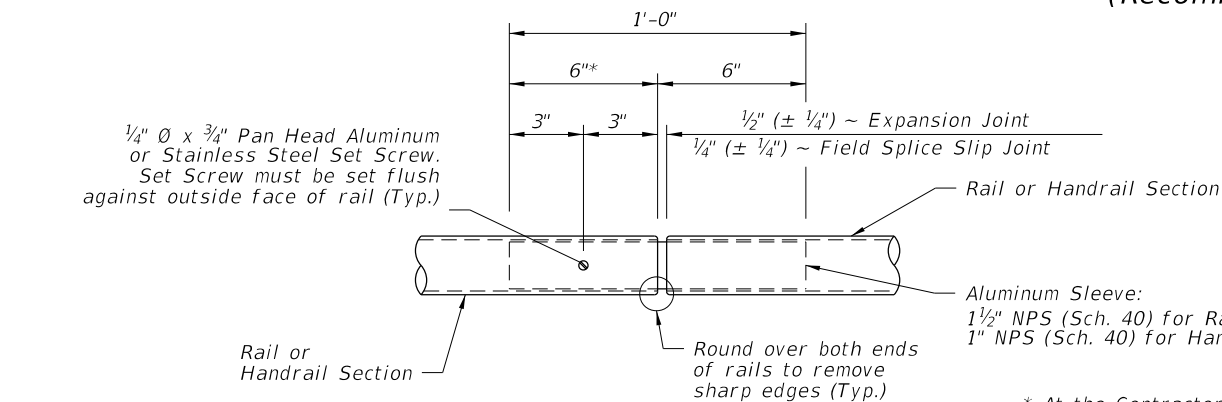

PLATE WASHER
DETAIL



ALTERNATE BASE
PLATE DETAIL
(Recommended for Steep Slopes)



DETAIL "D" - EXPANSION JOINT
(FIELD SPLICE SLIP JOINT SIMILAR)

* At the Contractor's option, embedded length may be 4" when a 3/4" Ø plug weld is substituted for the 1/4" Ø set screw.

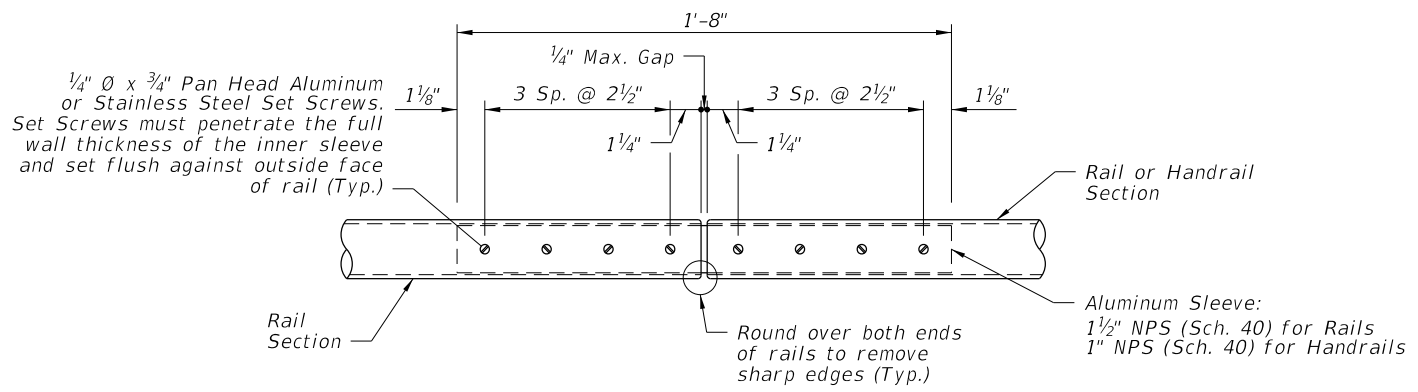

DETAIL "E" - CONTINUITY
FIELD SPLICE

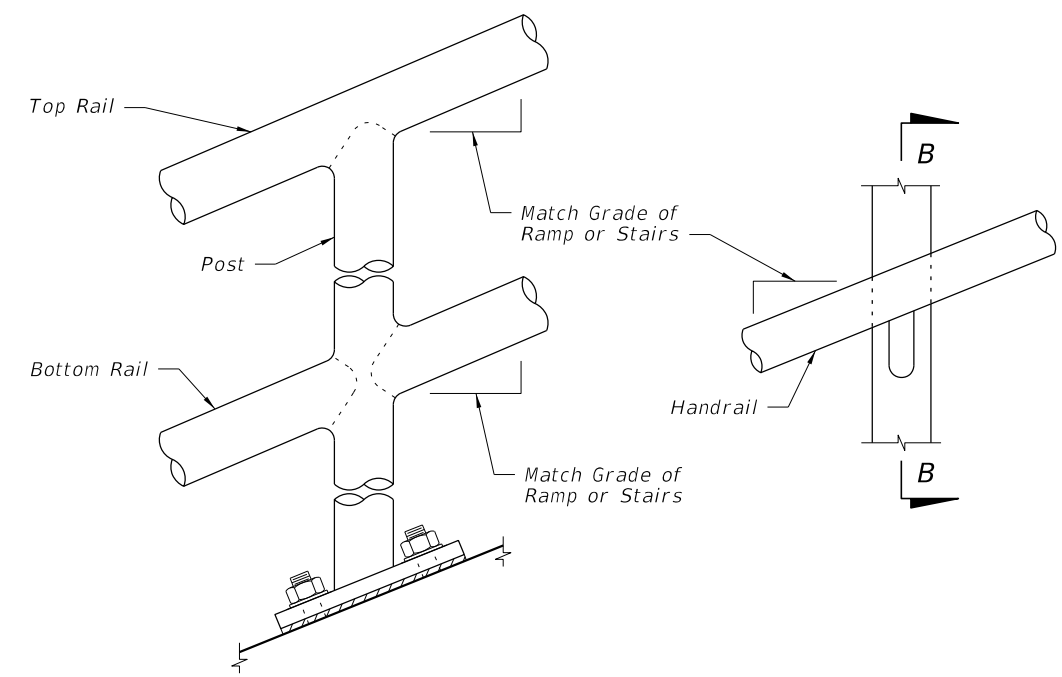

DETAIL "B" - RAIL AND HANDRAIL
(Showing Sloped Condition for Ramps with 2~Bolt Anchorage)

CROSS REFERENCE:
For locations of Details "C", "D" and "E", see Sheet 2.

10/20/2022 8:50:31 AM

LAST REVISION 11/01/17	REVISION	DESCRIPTION:		FY 2023-24 STANDARD PLANS	PIPE GUIDERAIL (ALUMINUM)	INDEX 515-070	SHEET 4 of 5
---------------------------	----------	--------------	--	------------------------------	---------------------------	------------------	-----------------

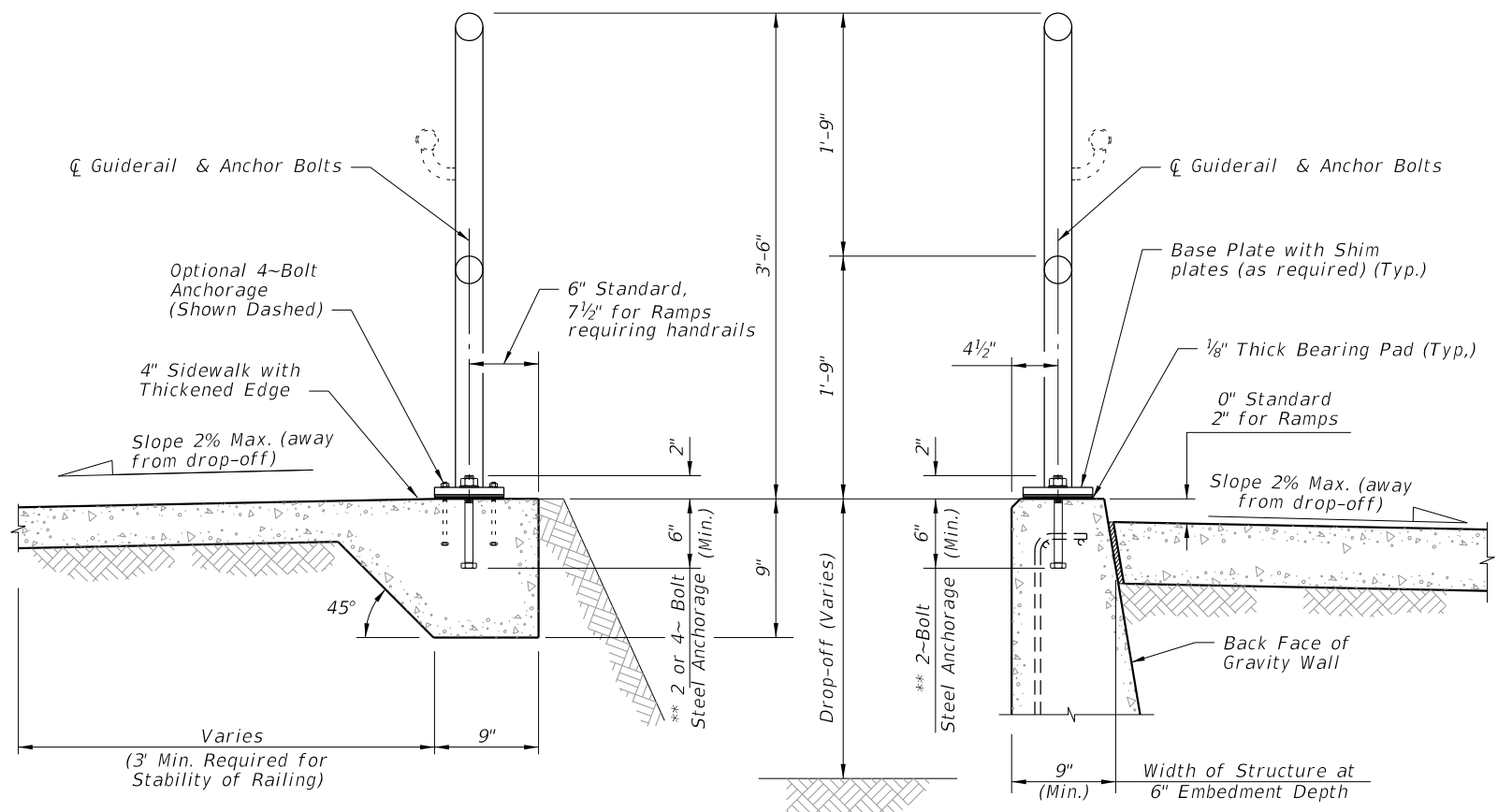

TYPICAL SECTION ON CONCRETE SIDEWALK

TYPICAL SECTION ON GRAVITY WALL
(Other Retaining Walls Similar)

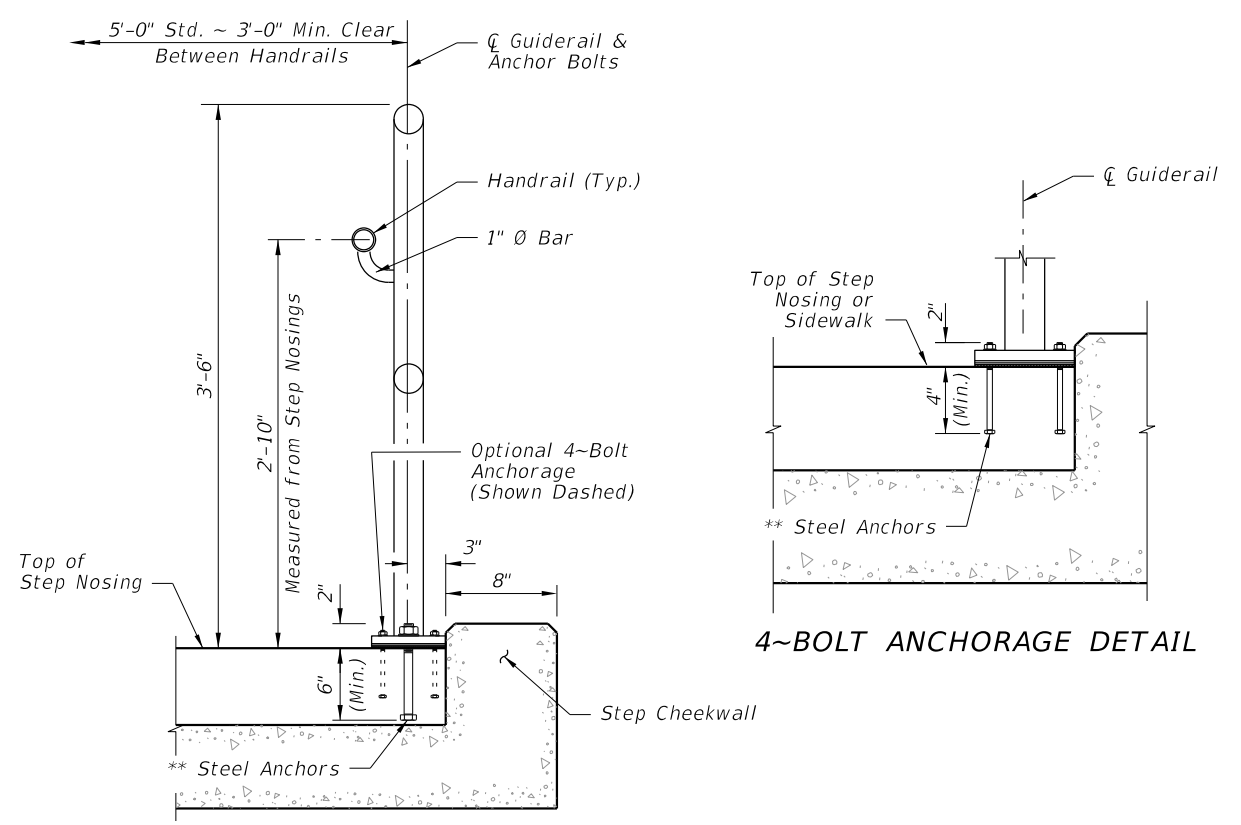

TYPICAL SECTION ON STEPS & STAIRS

4~BOLT ANCHORAGE DETAIL

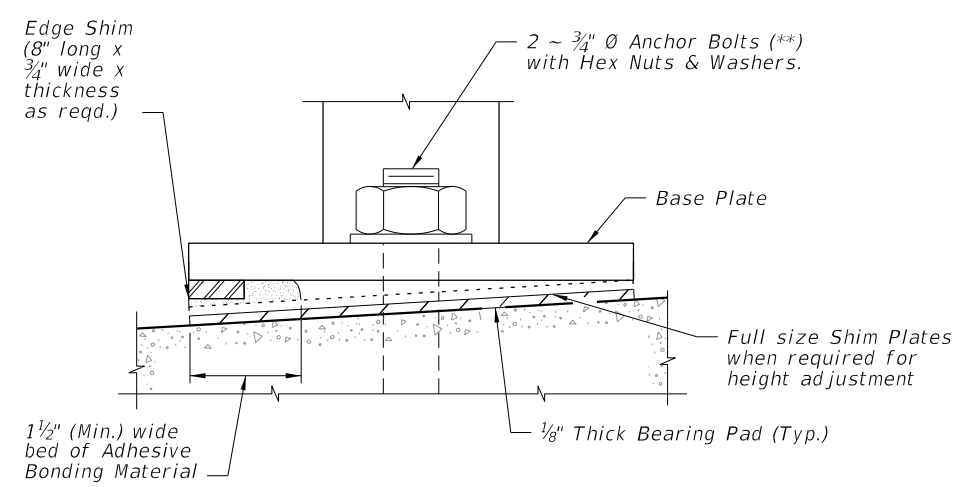

DETAIL "F" (OPTIONAL SHIMMING DETAIL FOR CROSS SLOPE CORRECTION)
(Used in lieu of Beveled Shim Plates)

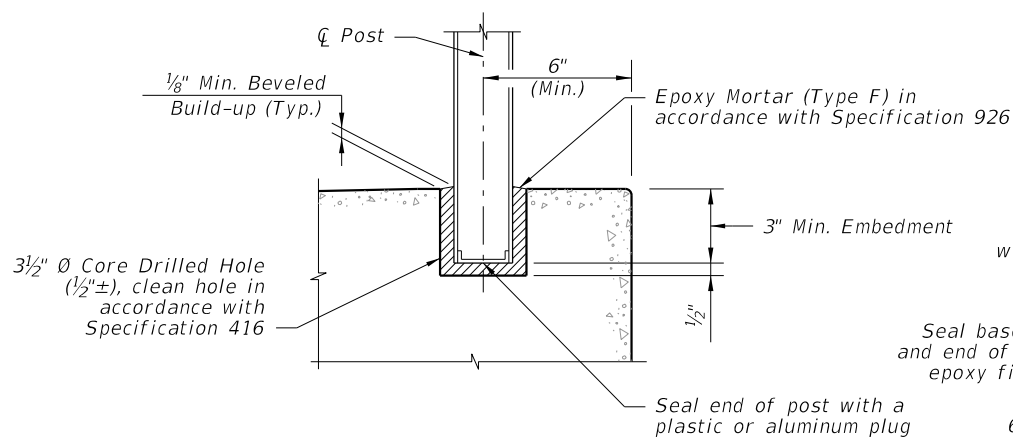

SIDEWALK ANCHORAGE DETAIL OPTION 1

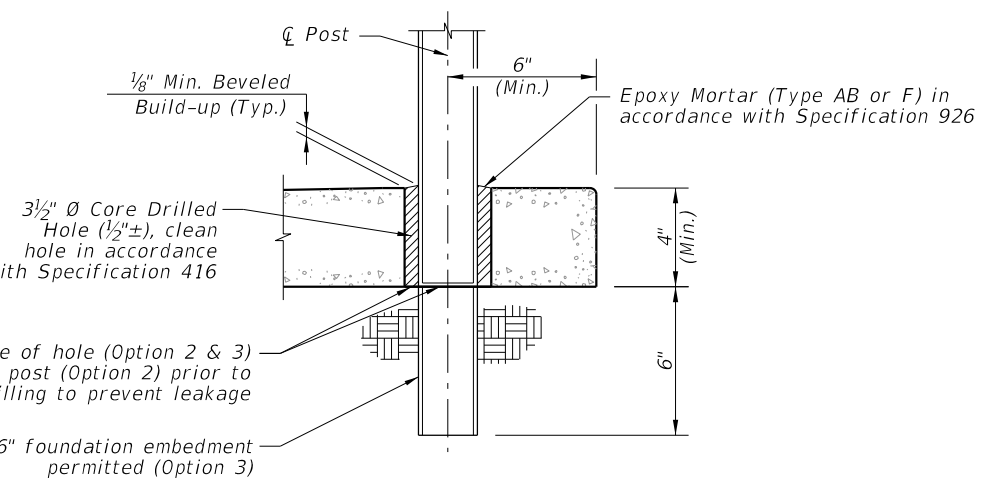

SIDEWALK ANCHORAGE DETAIL OPTION 2 & 3

NOTES:
 ** 2 - 3/4" \varnothing x 8" or 4 - 7/16" \varnothing x 6" Steel Anchors; Galvanized Steel Bolts (As Shown) (C-I-P); Galvanized U-Bolts Permitted (C-I-P); Galvanized Adhesive Anchors Permitted
 *** The minimum embedment for Adhesive Anchors is 6" for 2-Bolt Anchorage or 4" for 4-Bolt Anchorage.

10/20/2022 8:50:32 AM

LAST REVISION 11/01/20	REVISION	DESCRIPTION:		FY 2023-24 STANDARD PLANS	PIPE GUIDERAIL (ALUMINUM)	INDEX 515-070	SHEET 5 of 5
---------------------------	----------	--------------	--	------------------------------	---------------------------	------------------	-----------------

NOTES:

1. Shop Drawings are required, refer to Specification 515.

2. Materials:

- A. Pan Head Set Screws: Stainless Steel (SS) Type 316 or 18-8 Alloy.
- B. Base Plates and Cap Plates: ASTM A36 or ASTM A709 Grade 36
- C. Pipe Rails and Posts: ASTM A53 Grade B for standard weight pipe and ASTM A500 Grade B, C or D or ASTM A501 for Structural Tube.

Handrail Support Bars: ASTM A36

RAILING MEMBER DIMENSIONS TABLE			
MEMBER	DESIGNATION	OUTSIDE DIMENSION	WALL THICKNESS
Posts	2" NPS (Sch. 40)	2.375"	0.154"
Rails	2" NPS (Sch. 40)	2.375"	0.154"
Rail Joint/Splice Sleeves	1½" NPS (Sch. 40)	1.900"	0.145"
Handrails Joint/Splice Sleeves	1" NPS (Sch. 40) HSS1.500x0.125	1.315" 1.500"	0.133" 0.125"
Handrails	1½" NPS (Sch. 40)	1.900"	0.145"
Handrail Support Bar	1" Ø Round Bar	1.000"	N/A

D. Galvanized Steel Fasteners:

- a. Hex Head Bolts: ASTM A307 Type 1 or ASTM F1554 Grade 36
- b. Adhesive Anchors: ASTM F1554 Grade 36 fully threaded rods
- c. Hex Nuts: ASTM A563
- d. Flat Washers: ASTM F436
- E. Aluminum Shims: ASTM B209, Alloy 6061
- F. Bearing Pads: Plain, Fabric Reinforced, or Fabric Laminated meeting requirements of Specifications 515 and 932.

3. Fabrication:

- A. Place expansion joints at a maximum of 30'-0" spacing.
- B. Field splices are similar to the expansion joint detail and may be approved by the Engineer to facilitate handling; but top rail must be continuous across a minimum of two posts.
- C. Continuity field splice (Detail "E") only use to make the railing continuous for unforeseen field adjustments
- D. Corners and changes in tangential longitudinal alignment may be made continuous with a 9" bend radius or terminated at adjoining sections with a standard end hoop when handrails are not required.
- E. For curved longitudinal alignments, shop bend the top and bottom rails and handrails to match the alignment radius.
- F. For changes in tangential longitudinal alignment greater than 45°, positioned posts a maximum of 2'-0" each side of the corner, not at the corner apex.

4. Handrails are required and must be continuous at landings for:

- A. Grades Steeper than 5%.
- B. Three or more steps

5. Cutting of reinforcing steel is permitted for adhesive anchor bolt installations.

10/20/2022 8:50:33 AM

LAST REVISION 11/01/17	REVISION	DESCRIPTION:	 FY 2023-24 STANDARD PLANS	PIPE GUIDERAIL (STEEL)	INDEX 515-080	SHEET 1 of 5
---------------------------	----------	--------------	---	-------------------------------	-------------------------	------------------------

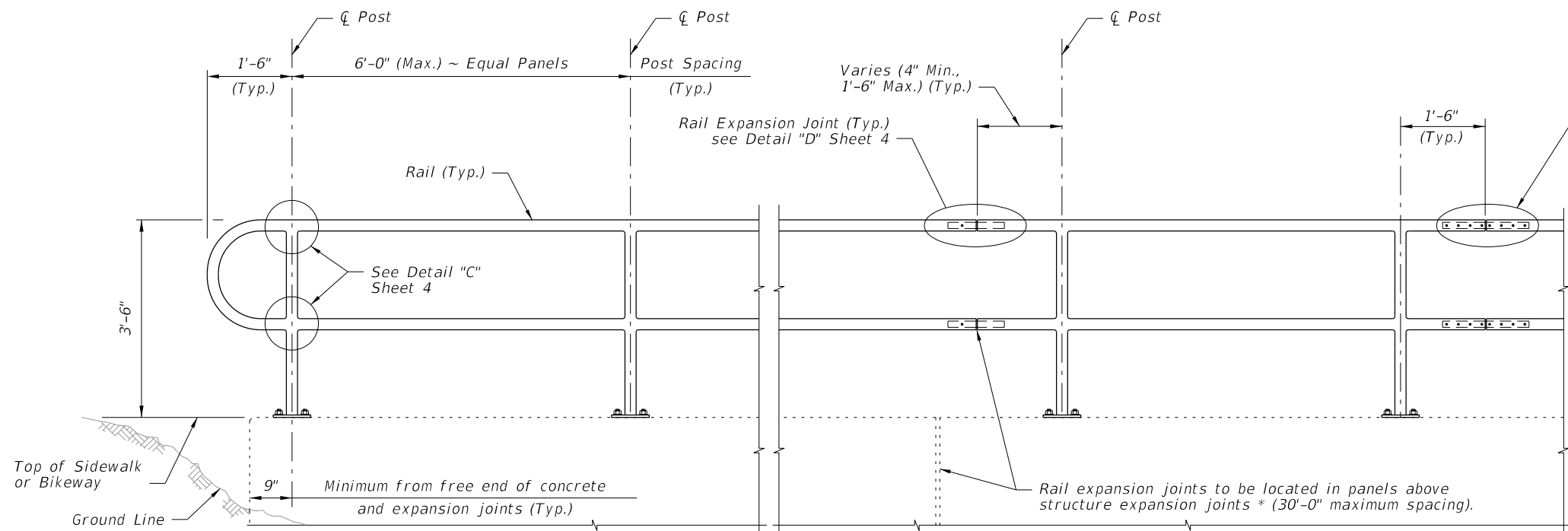

NOTES:
 NPS = Nominal Pipe Size
 STRUCTURES EXPANSION JOINTS NOTE:
 * Keyed construction joints in Index 400-011 Gravity Wall are not considered to be expansion joints.

CROSS REFERENCE:
 For Details "C", "D" and "E", see Sheet 4.

ELEVATION

TYPICAL RAILING DETAILS & RAILINGS ON GRADES 0% TO 5%

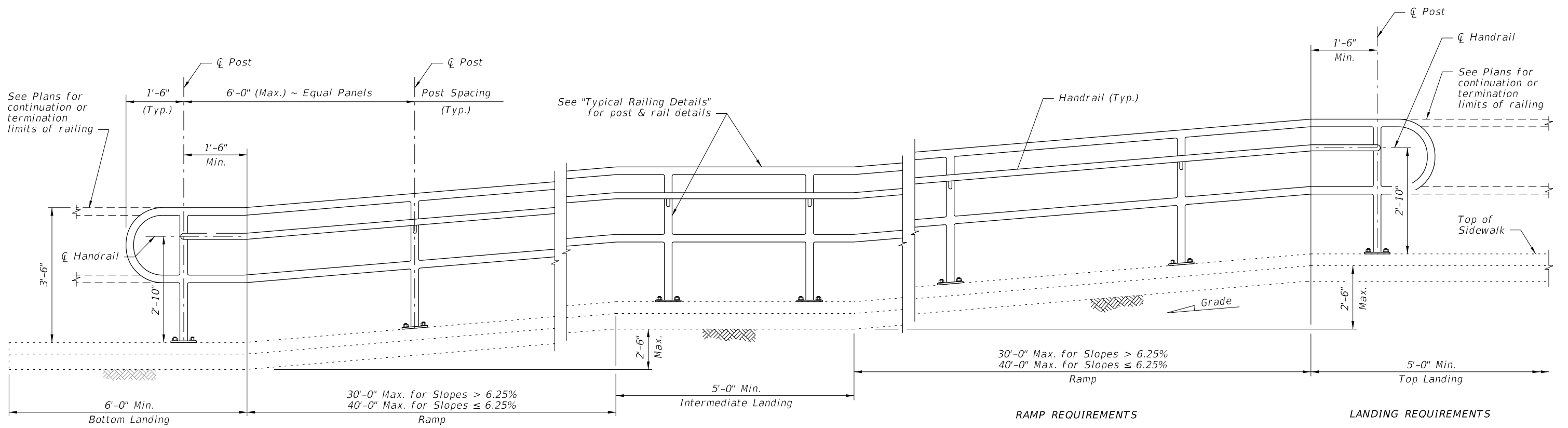

ELEVATION
 (Showing Inside Face of Railing)

RAMP REQUIREMENTS
 30'-0" Max. for Slopes > 6.25%
 40'-0" Max. for Slopes ≤ 6.25%

LANDING REQUIREMENTS
 5'-0" Min. Top Landing
 Max. landing slope = 2%
 Max. landing cross-slope = 2%

RAILINGS ON GRADES STEEPER THAN 5% TO 8.33%

10/20/2022 8:50:34 AM

LAST REVISION 11/01/17	REVISION	DESCRIPTION:		FY 2023-24 STANDARD PLANS	PIPE GUIDERAIL (STEEL)	INDEX 515-080	SHEET 2 of 5
---------------------------	----------	--------------	--	------------------------------	------------------------	------------------	-----------------

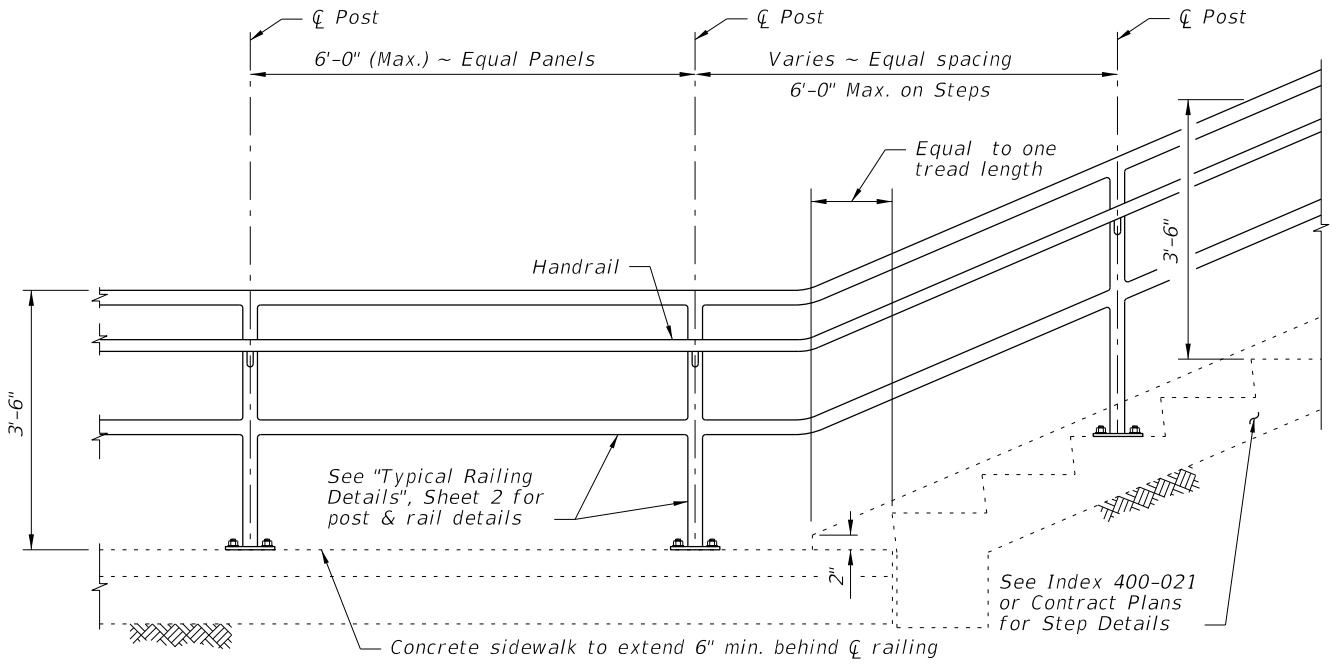

RAILING CONTINUATION BEYOND STEPS
(Bottom shown, Top similar)

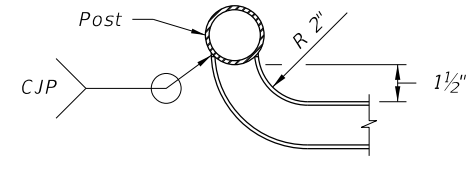

DETAIL "A" - PLAN VIEW
HANDRAIL TERMINATION

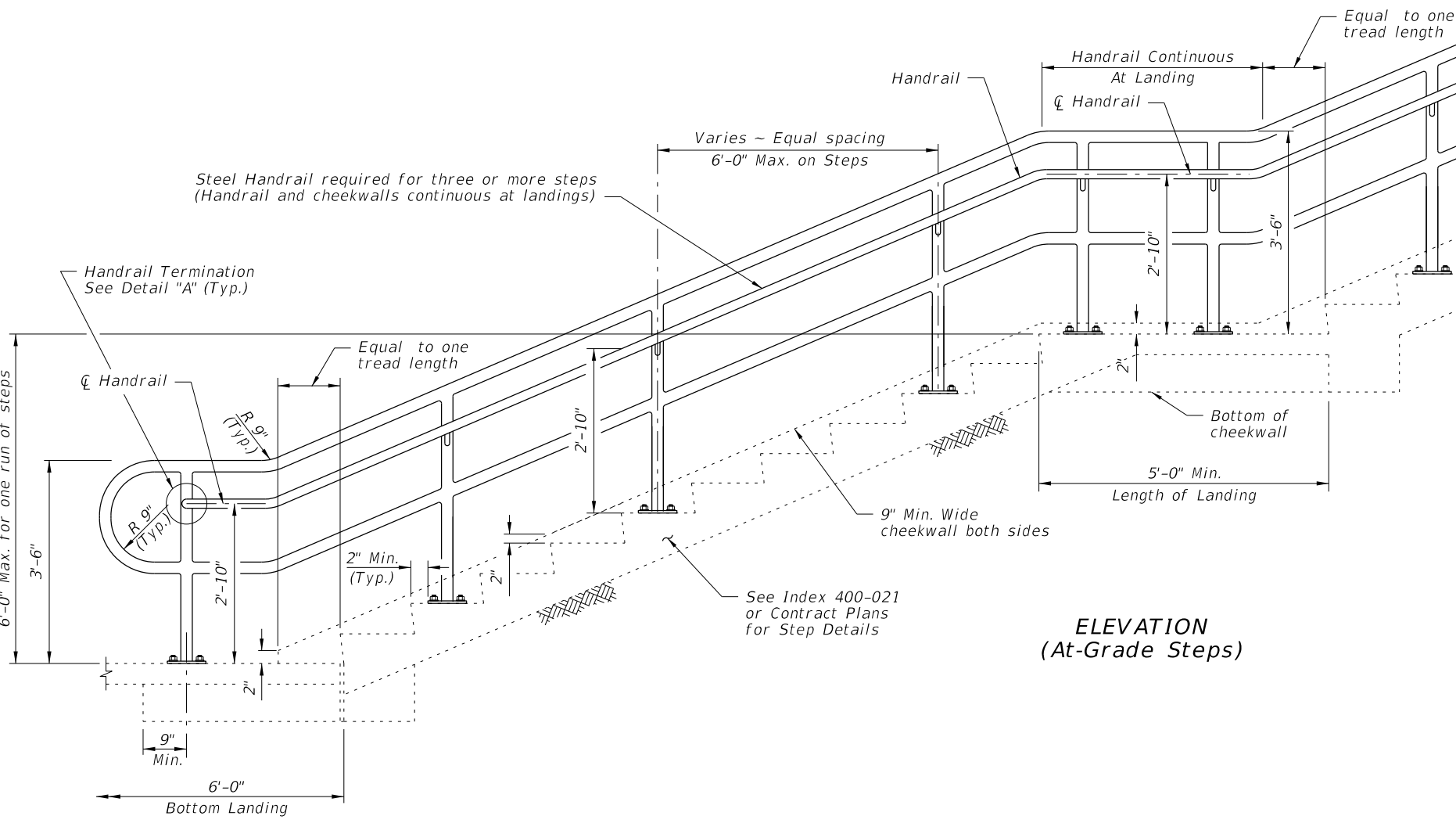
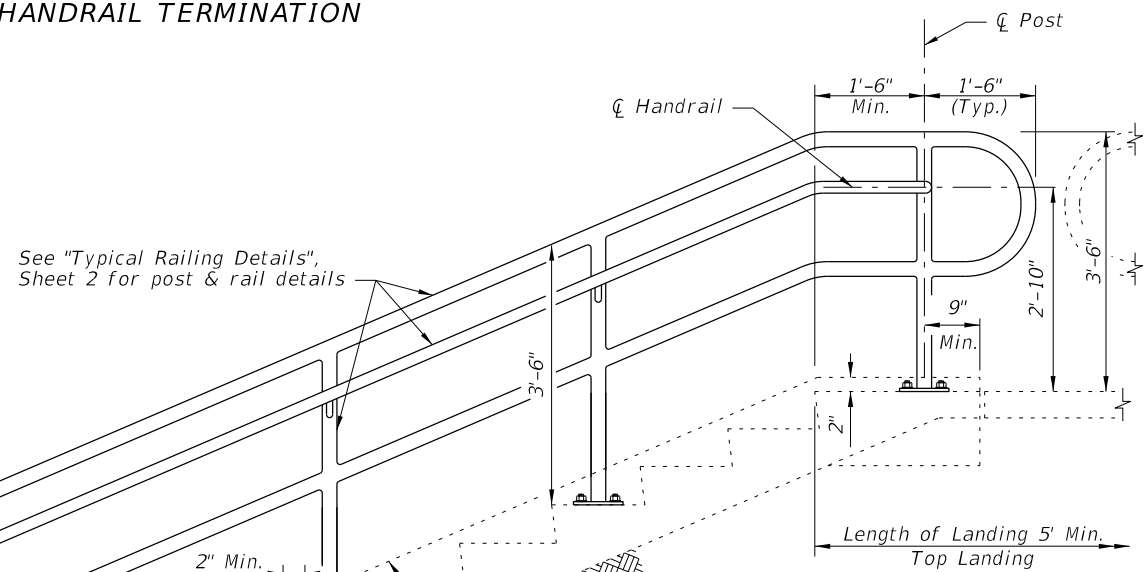

ELEVATION
(At-Grade Steps)

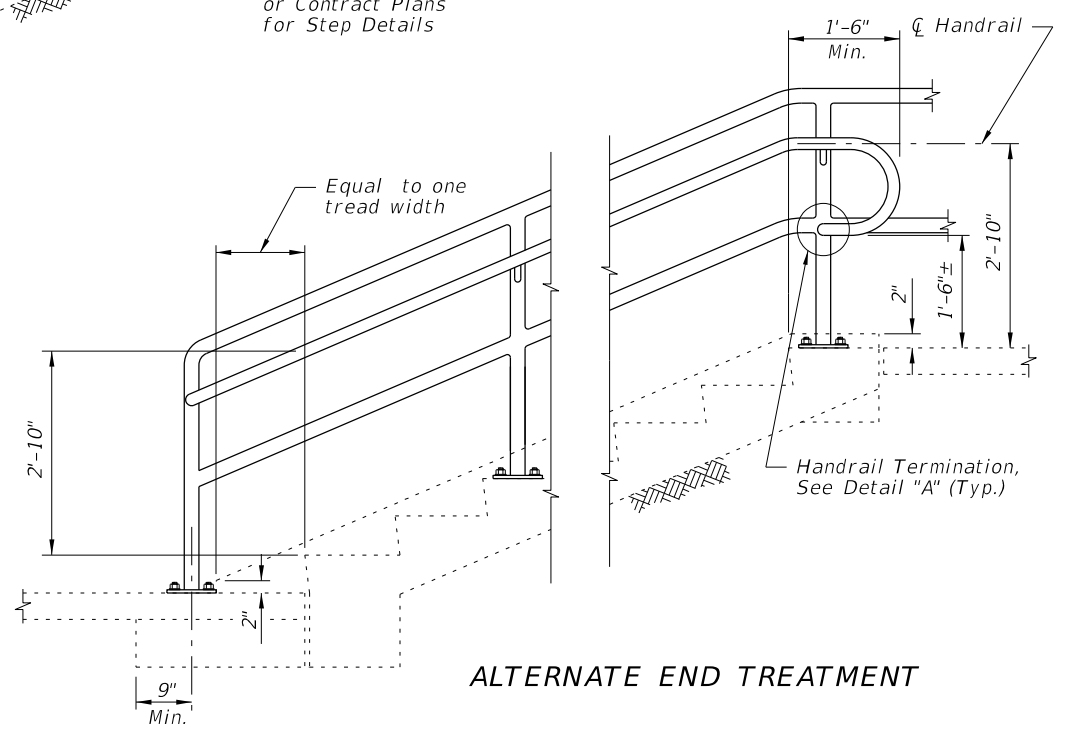

ALTERNATE END TREATMENT

GUIDERAIL ON STEPS & STAIRS

10/20/2022 8:50:34 AM

LAST REVISION 11/01/17	REVISION	DESCRIPTION:		FY 2023-24 STANDARD PLANS	PIPE GUIDERAIL (STEEL)	INDEX 515-080	SHEET 3 of 5
---------------------------	----------	--------------	--	-------------------------------------	-------------------------------	-------------------------	------------------------

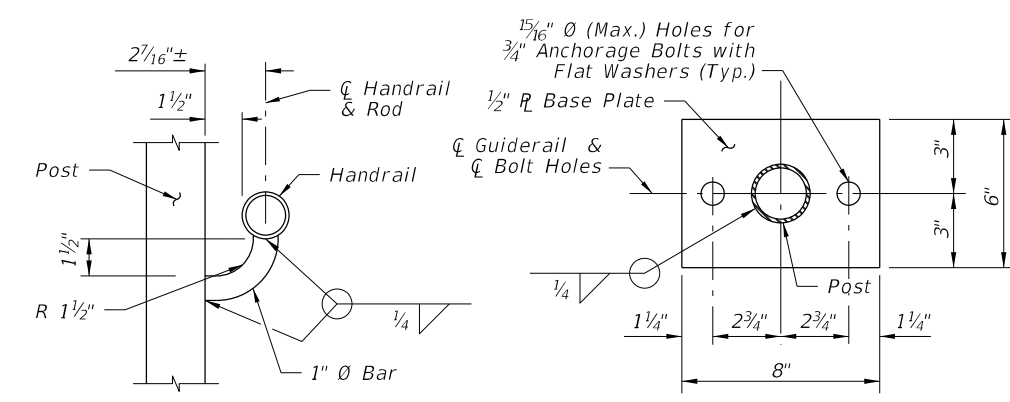

SECTION B-B (Handrail Connection)

SECTION C-C BASE PLATE DETAIL (2-Bolt Anchorage)

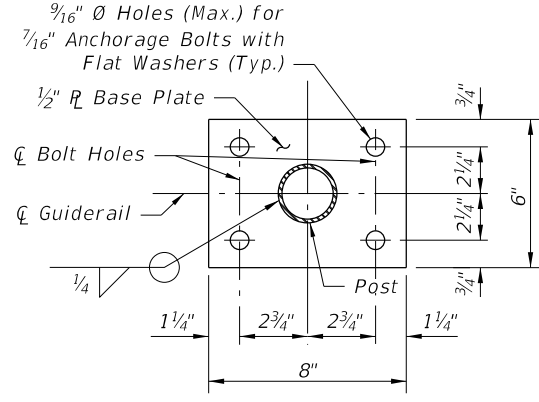

SECTION C-C BASE PLATE DETAIL (4-Bolt Anchorage)

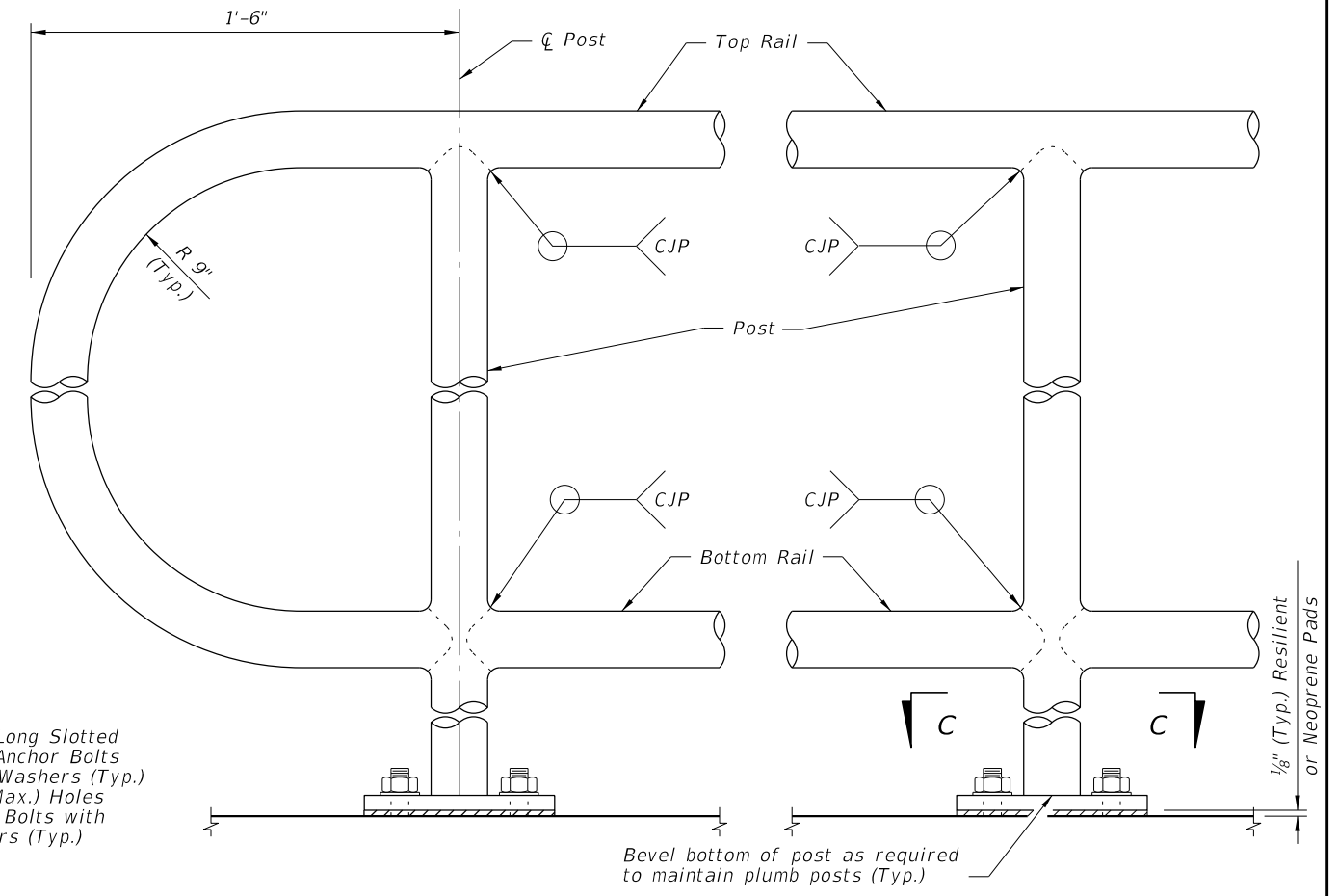

DETAIL "C" - RAIL CONNECTIONS (Handrail and 4-Bolt Anchorage Not Shown)

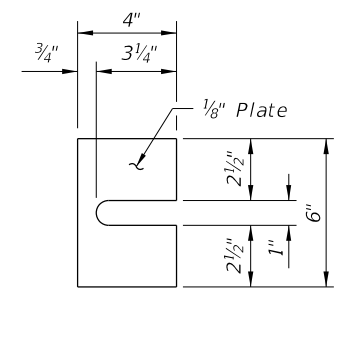

SHIM PLATE DETAIL (2-Bolt Anchorage)

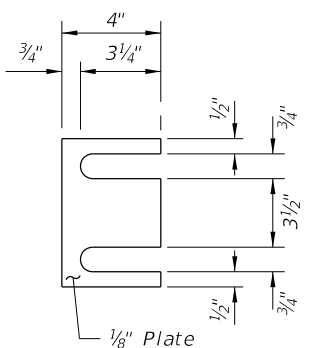

SHIM PLATE DETAIL (4-Bolt Anchorage)

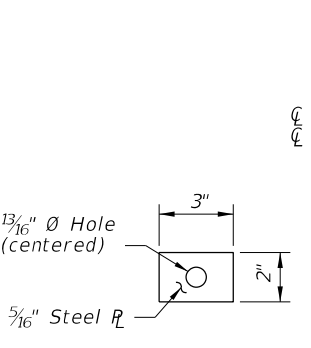
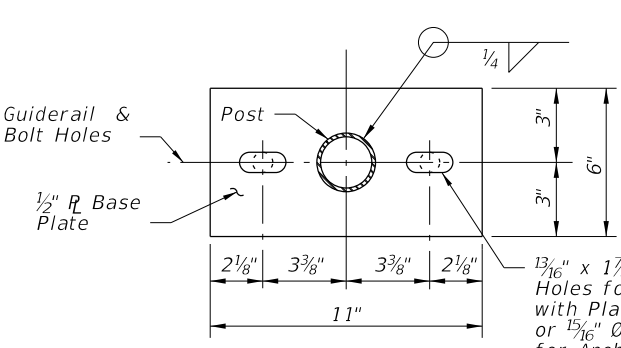
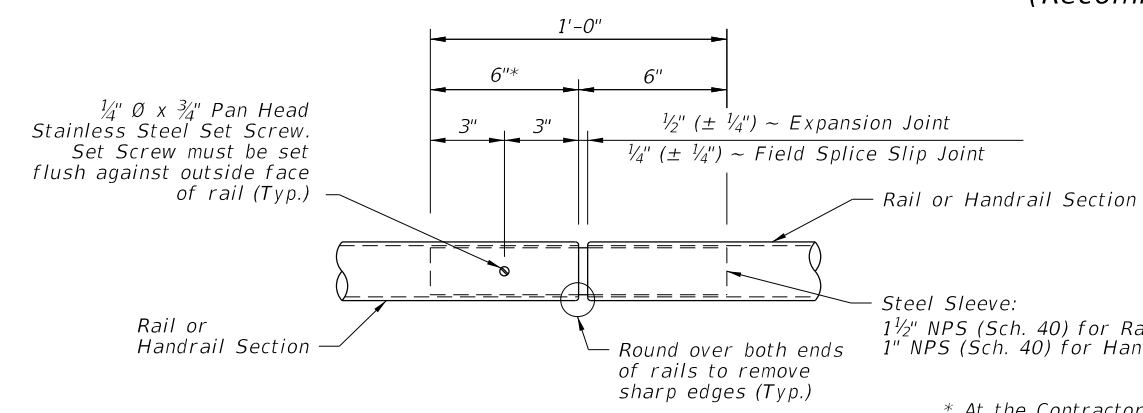

PLATE WASHER DETAIL



ALTERNATE BASE PLATE DETAIL (Recommended for Steep Slopes)



DETAIL "D" - EXPANSION JOINT (FIELD SPLICE SLIP JOINT SIMILAR)

* At the Contractor's option, embedded length may be 4" when a 3/4" Ø plug weld is substituted for the 1/4" Ø set screw.

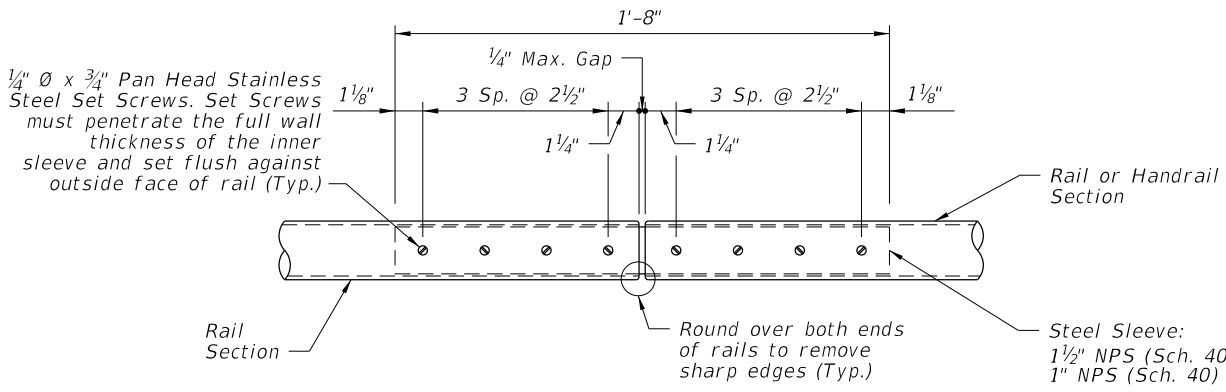

DETAIL "E" - CONTINUITY FIELD SPLICE

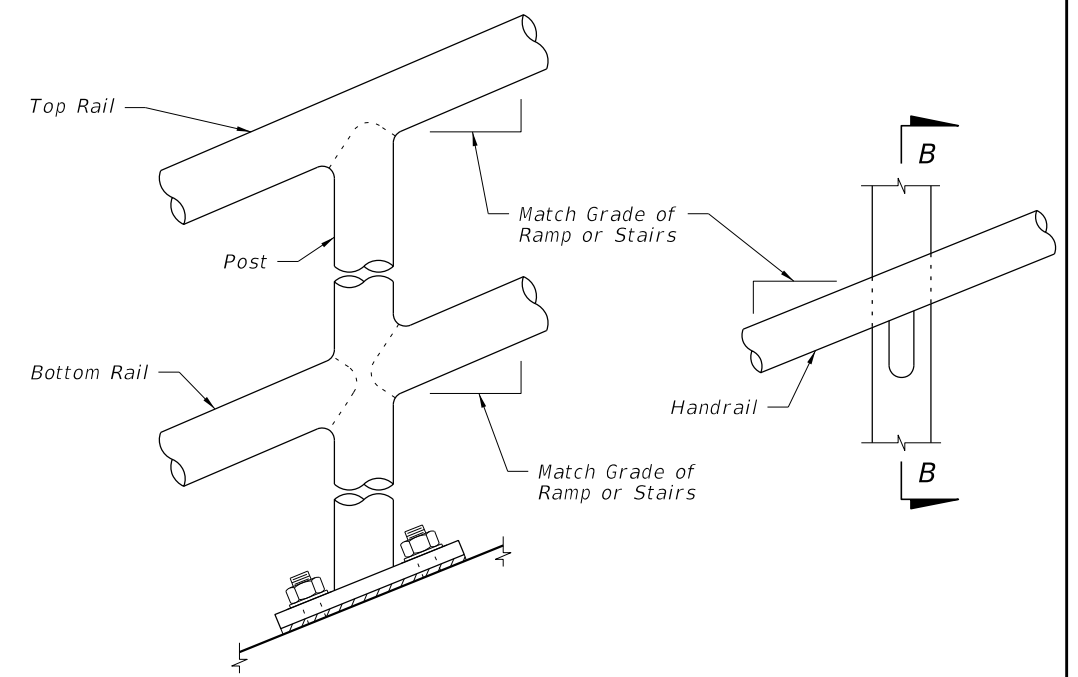

DETAIL "B" - RAIL AND HANDRAIL (Showing Sloped Condition for Ramps with 2-Bolt Anchorage)

CROSS REFERENCE: For locations of Details "C", "D" and "E", see Sheet 2.

10/20/2022 8:50:35 AM

LAST REVISION 11/01/17	REVISION	DESCRIPTION:		FY 2023-24 STANDARD PLANS	PIPE GUIDERAIL (STEEL)	INDEX 515-080	SHEET 4 of 5
---------------------------	----------	--------------	--	------------------------------	------------------------	------------------	-----------------

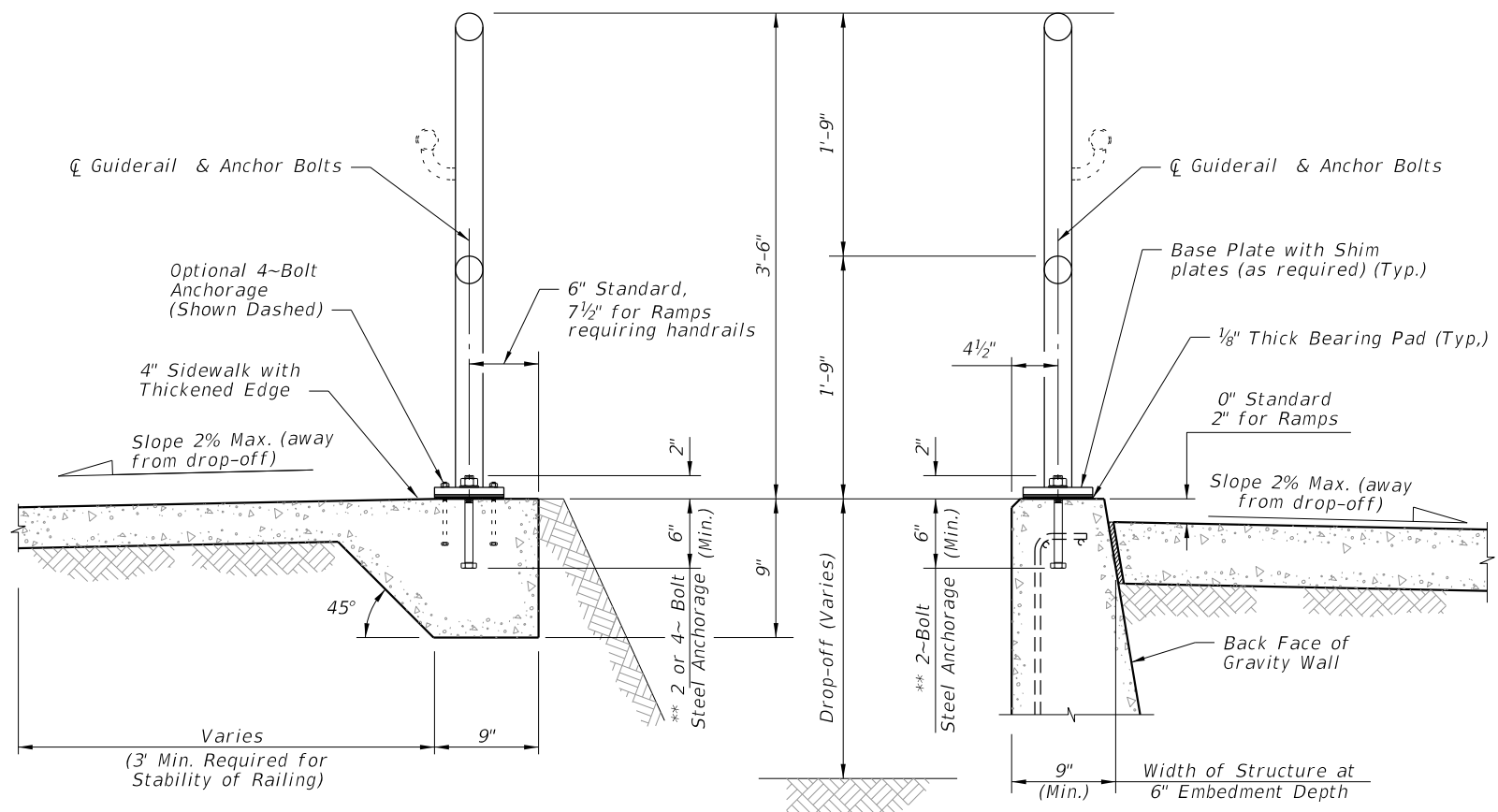

TYPICAL SECTION ON CONCRETE SIDEWALK

TYPICAL SECTION ON GRAVITY WALL
(Other Retaining Walls Similar)

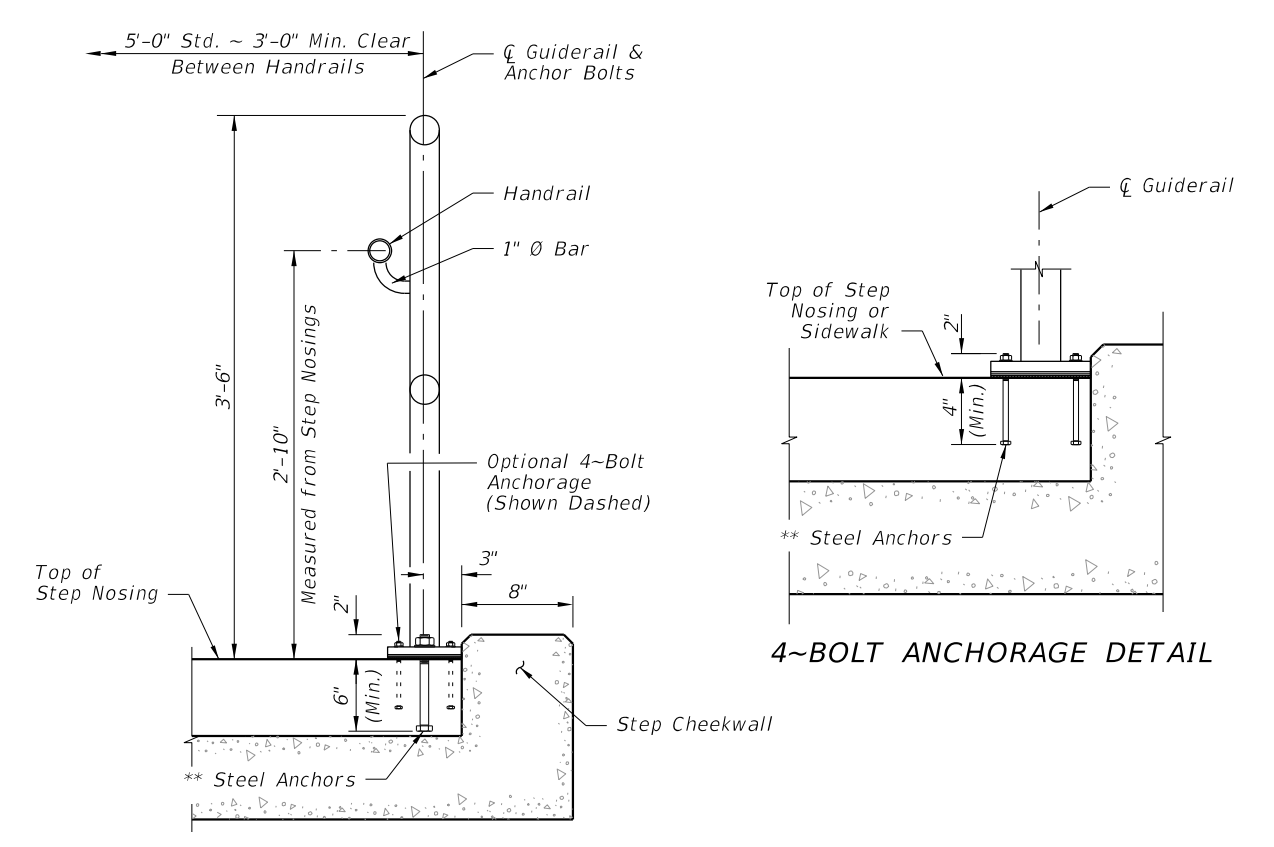

TYPICAL SECTION ON STEPS & STAIRS

4~BOLT ANCHORAGE DETAIL

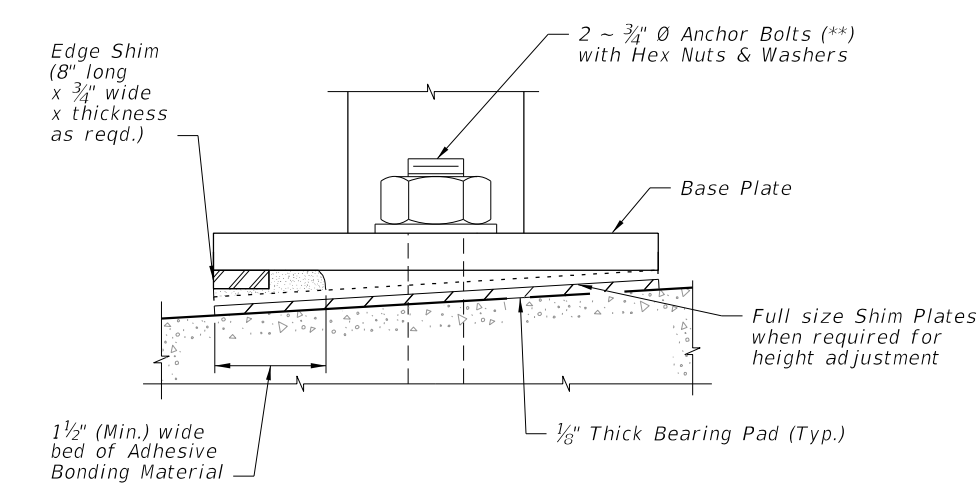

DETAIL "F" (OPTIONAL SHIMMING DETAIL FOR CROSS SLOPE CORRECTION)
(Used in lieu of Beveled Shim Plates)

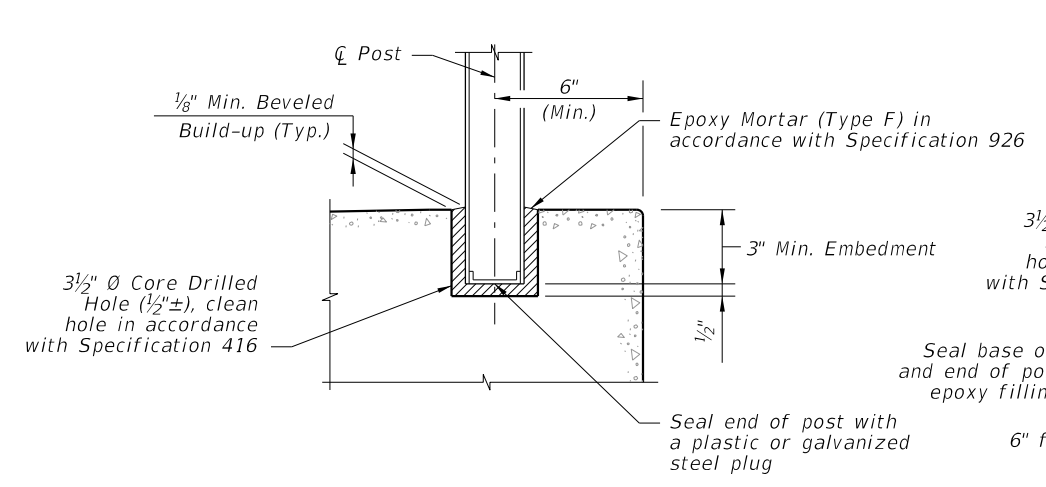

OPTIONAL SIDEWALK ANCHORAGE DETAIL

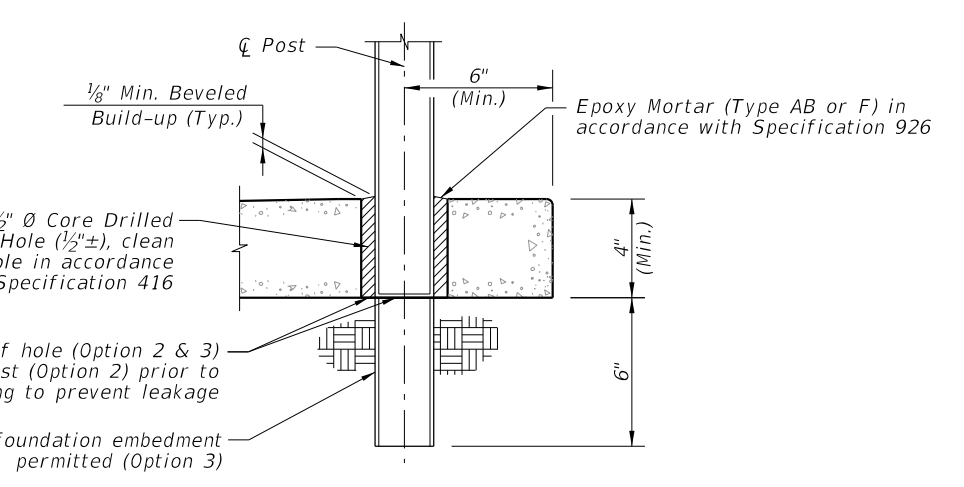

SIDEWALK ANCHORAGE DETAIL
OPTION 2 & 3

NOTES:
 **2 ~ 3/4" Ø x 8" or 4 ~ 7/16" Ø x 6" Steel Anchors:
 Galvanized Steel Bolts (As Shown) (C-I-P); Galvanized U-Bolts Permitted (C-I-P); Galvanized Adhesive Anchors Permitted (**); Expansion Anchors Not Permitted.

*** The minimum embedment for adhesive anchors is 6" for 2-Bolt Anchorage or 4" for 4-Bolt Anchorage.

10/20/2022 8:50:36 AM

LAST REVISION 11/01/20	REVISION	DESCRIPTION:		FY 2023-24 STANDARD PLANS	PIPE GUIDERAIL (STEEL)	INDEX 515-080	SHEET 5 of 5
---------------------------	----------	--------------	--	------------------------------	------------------------	------------------	-----------------

GENERAL NOTES:

1. For curb, gutter and curb & gutter provide $\frac{1}{8}$ " - $\frac{1}{4}$ " contraction joints at 10' centers (max.). Contraction joints adjacent to concrete pavement on tangents and flat curves are to match the pavement joints, with intermediate joints not to exceed 10' centers.
2. Locate expansion joints for curb, gutter and curb & gutter in accordance with Specification 520.

TABLE OF CONTENTS:	
Sheet	Description
1	General Notes and Contents
2	Concrete Curb and Gutter
3	Curb and Gutter Joints and Endings, Concrete Bumper Guard, and Asphaltic Concrete Curb

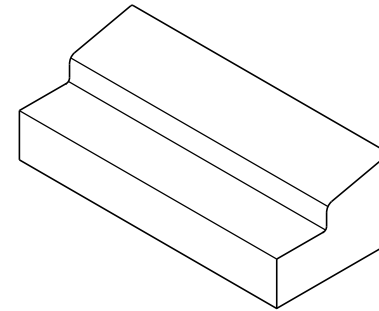

TYPE A

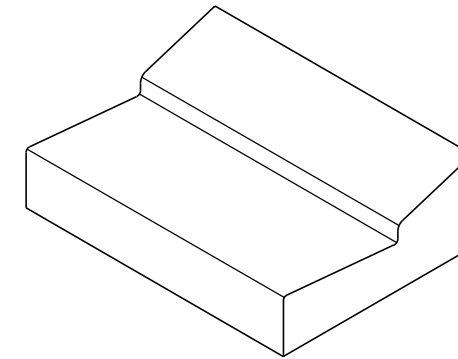

TYPE E

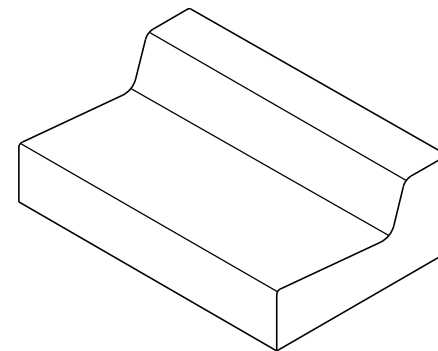

TYPE F

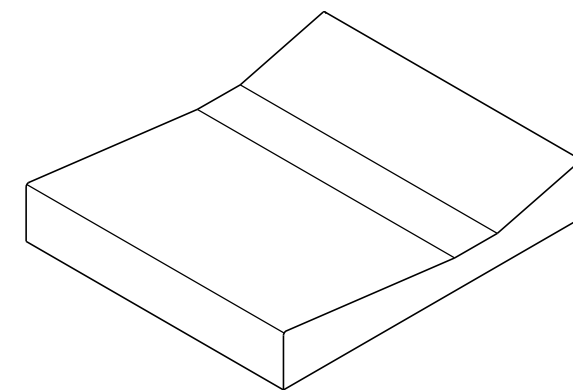

SHOULDER GUTTER

===== TYPE A, TYPE E, TYPE F, AND SHOULDER GUTTER =====
(Other Types Similar)

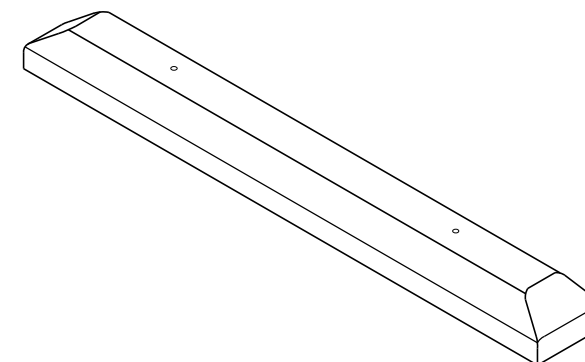

===== CONCRETE BUMPER GUARD =====

10/20/2022 8:50:37 AM

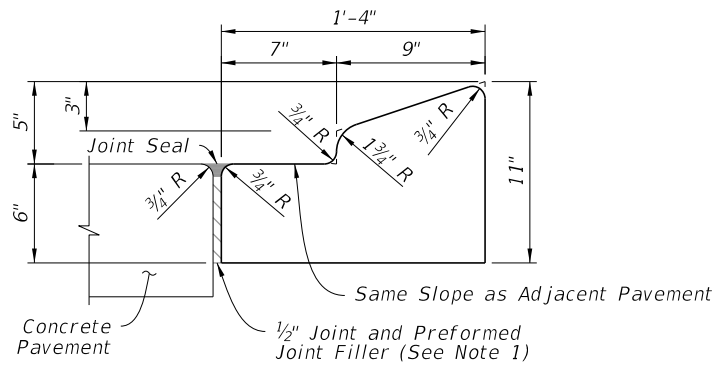

NOTE: For use adjacent to concrete or flexible pavement, concrete shown (See Note 4).

TYPE A

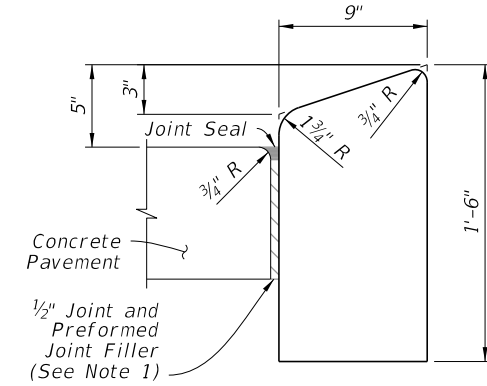

NOTE: For use adjacent to concrete or flexible pavement, concrete shown.

TYPE B

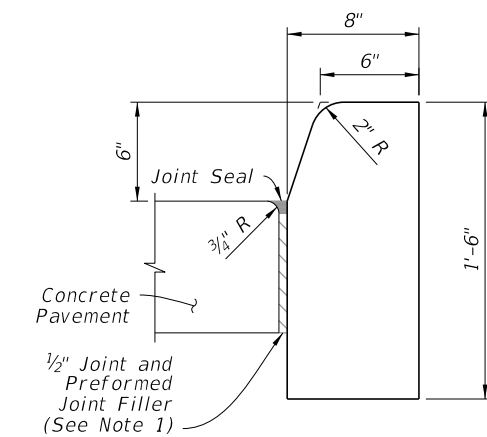

NOTE: For use adjacent to concrete or flexible pavement, concrete shown.

TYPE D

- NOTES:**
- For Type A, Type B, and Type D Curb: Expansion joint, preformed joint filler and joint seal are required between curbs and concrete pavement only, see Sheet 3.
 - For Type E, Type F, Drop Curb, and Valley Gutter: When used on high side of roadways, match the cross slope of the gutter to the cross slope of the adjacent pavement. The thickness of the lip is 6", unless otherwise shown on Plans.
 - For Type RA, rotate entire section so that gutter cross slope matches slope of adjacent circulating roadway pavement.
 - For details depicting usage of Type A Curb adjacent to flexible pavement see Sheet 3.

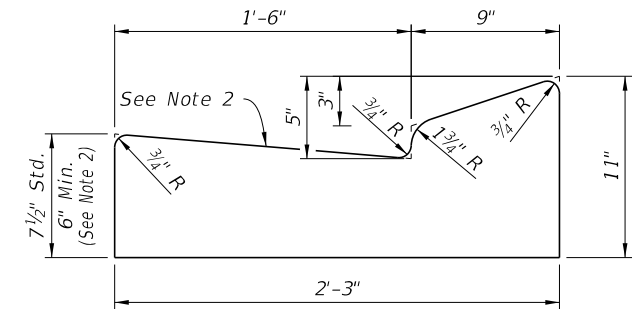

TYPE E

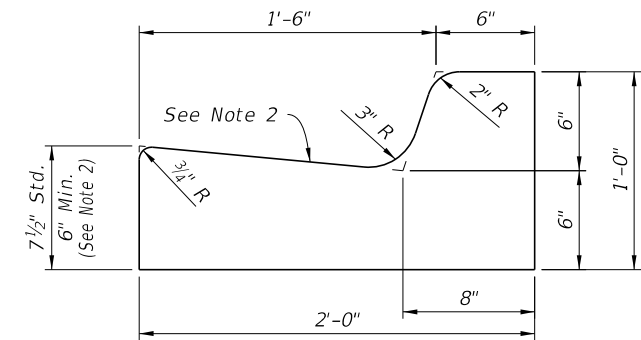

TYPE F

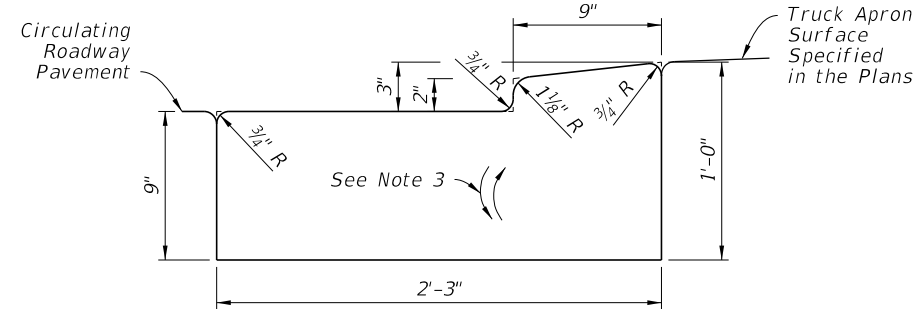

NOTE: Traffic Bearing Sections for use in Roundabout Central Island Construction.

TYPE RA

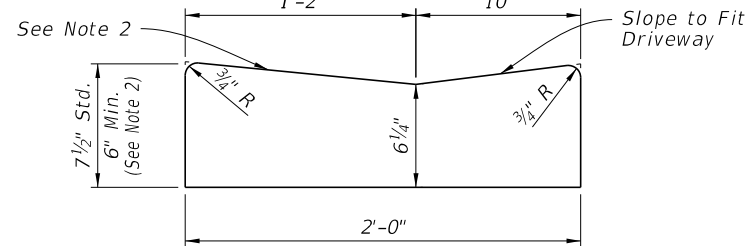

DROP CURB

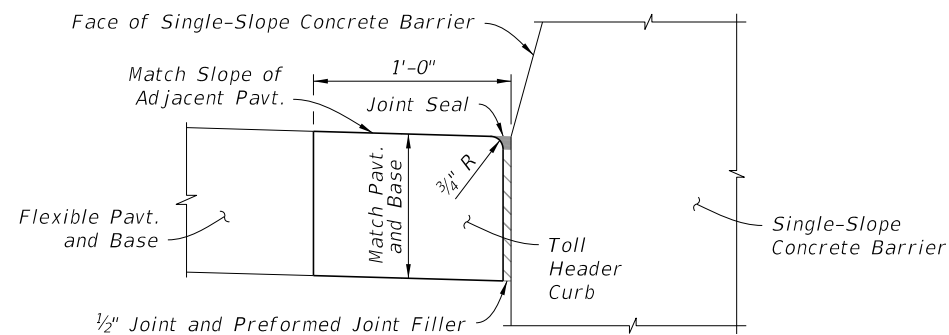

NOTE: See the toll site details for conduit requirements.

TOLL HEADER CURB

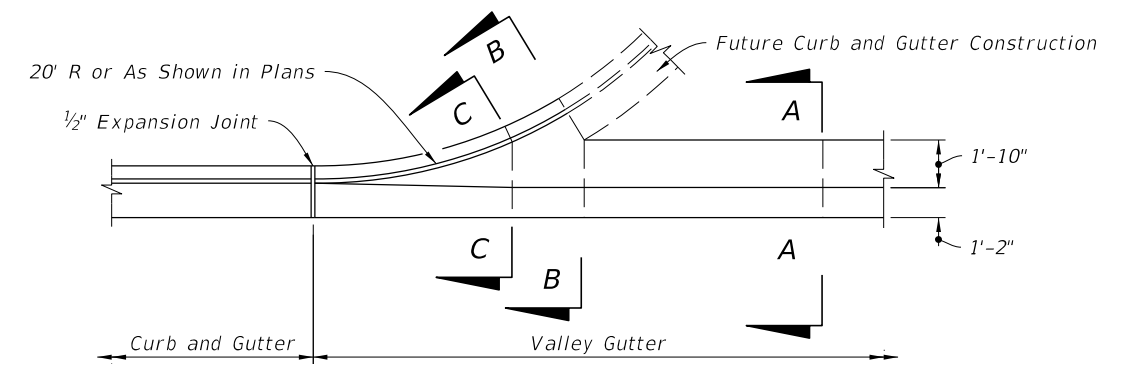

PLAN VIEW

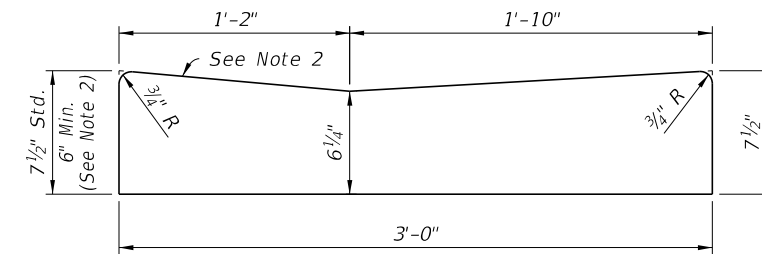

SECTION A-A

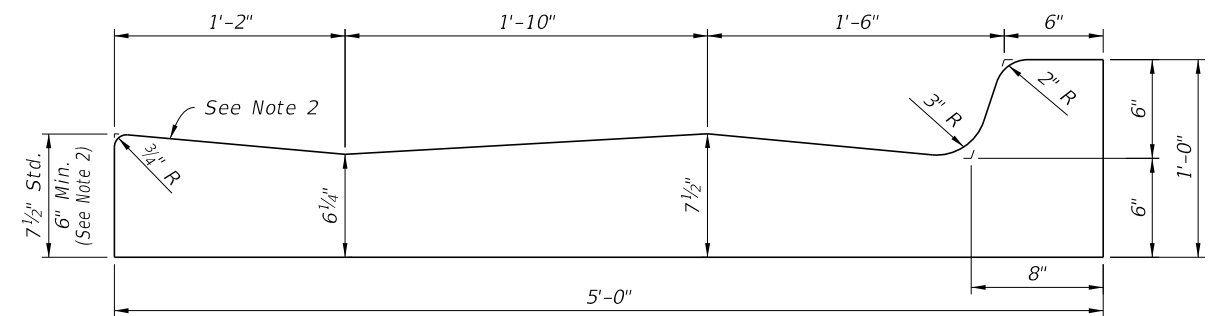

SECTION B-B

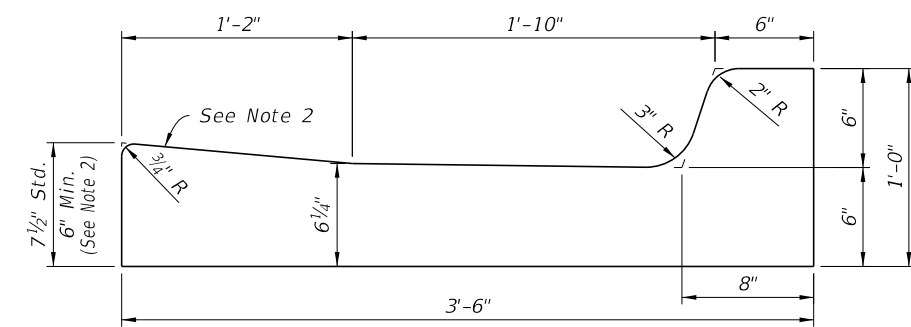

SECTION C-C

VALLEY GUTTER

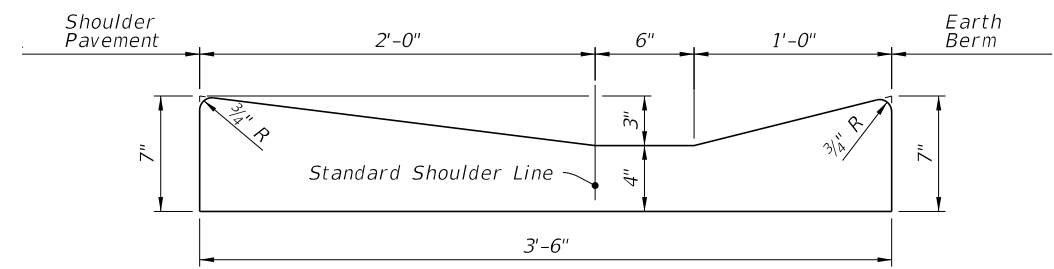

SHOULDER GUTTER

CONCRETE CURB AND GUTTER

CURB AND GUTTER

LAST REVISION	DESCRIPTION:
11/01/21	



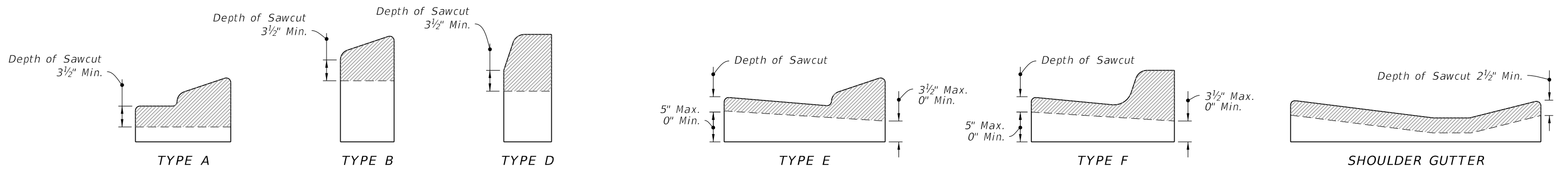

NOTE: Sawcuts should be avoided within valley gutter and within curb and gutter endings.

CONTRACTION JOINTS IN CURB

CONTRACTION JOINTS IN CURB & GUTTER

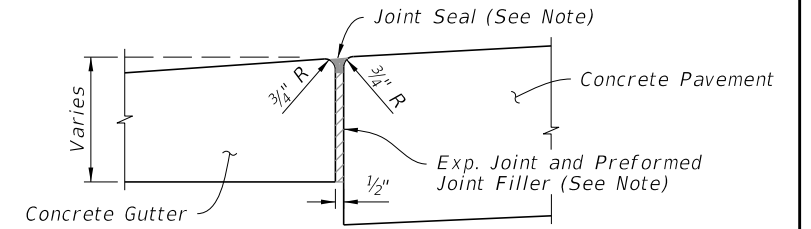
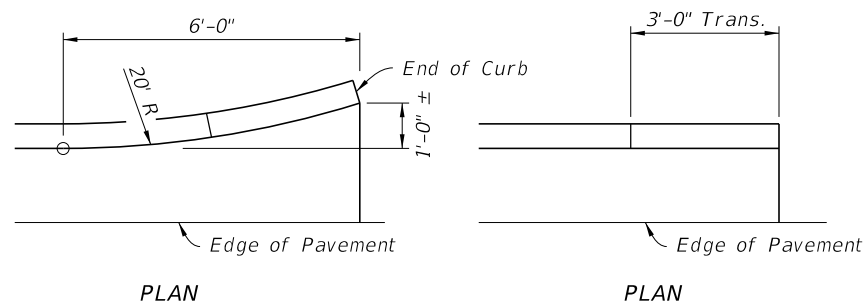
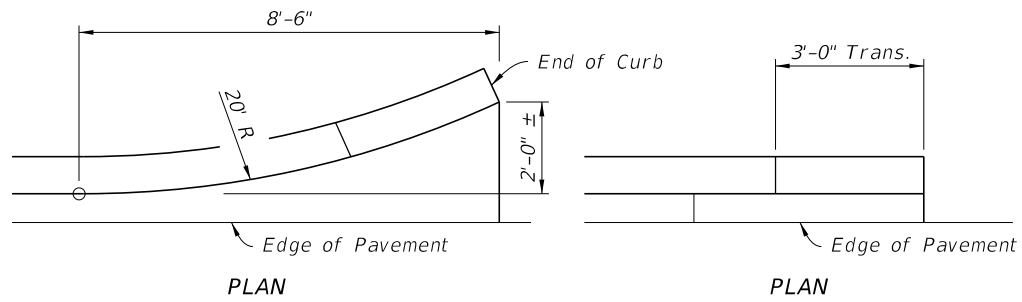

NOTE: Joint Seal application applies to both high and low sides of pavement, low side shown.

EXPANSION JOINT BETWEEN GUTTER AND CONCRETE PAVEMENT

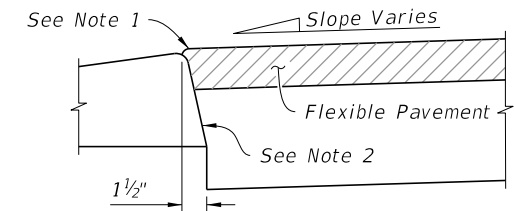
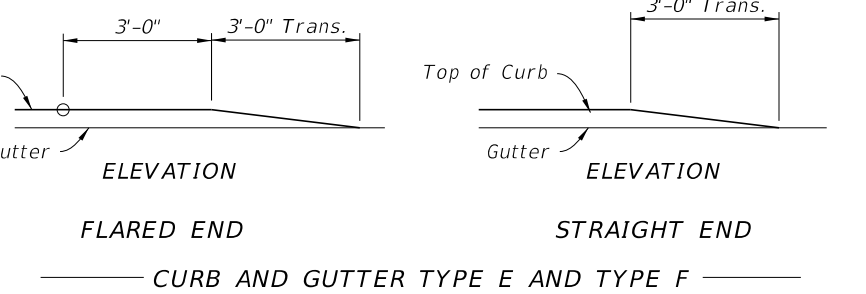
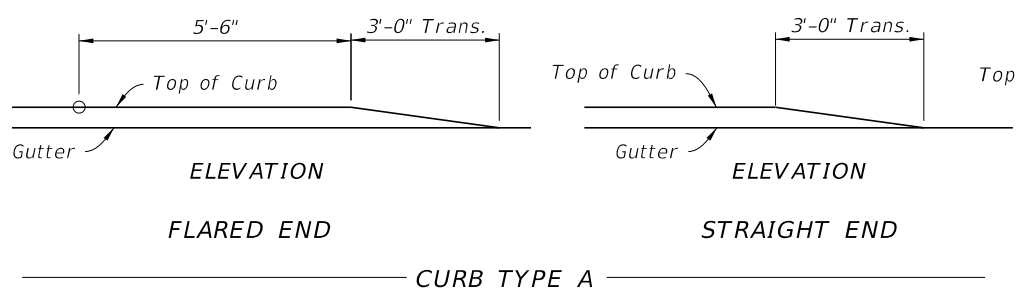

NOTES:

1. Surface on Low Side of Pavement to be 1/4" Above Lip of Gutter. Surface on High Side to be Flush With Lip of Curb or Curb & Gutter.
2. Applies to both high and low sides of pavement, low side shown. Applies to shoulder gutter only where adjoining traffic lanes.

CURB AND CURB & GUTTER ENDINGS

NOTE: Ends of Type B and D Curb transition from full to zero heights in 3 ft.

CURB AND GUTTER AND TYPE A CURB ADJACENT TO FLEXIBLE PAVEMENT

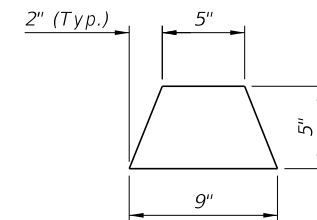
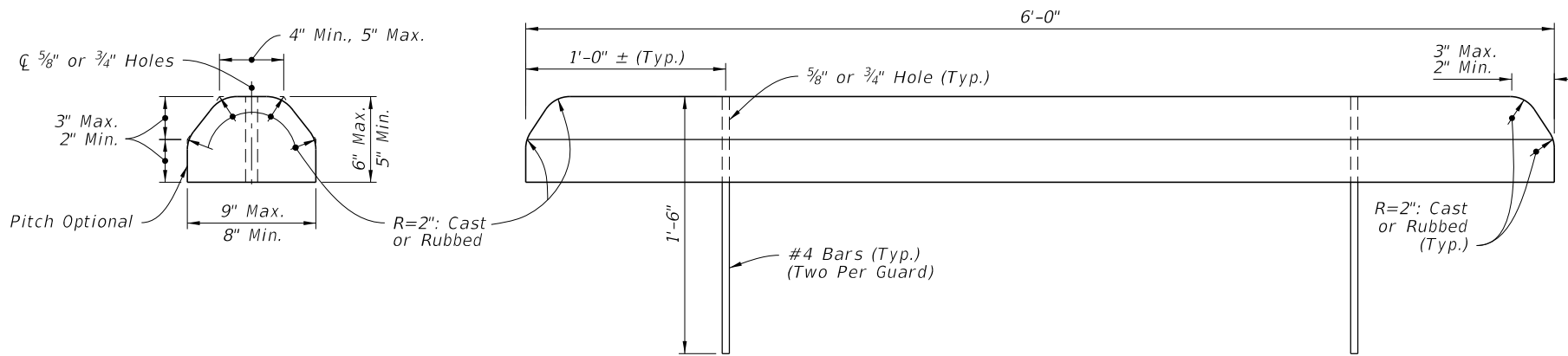

CONCRETE BUMPER GUARD

ASPHALTIC CONCRETE CURB

CURB AND GUTTER JOINTS AND ENDINGS, CONCRETE BUMPER GUARD, AND ASPHALTIC CONCRETE CURB

10/20/2022 8:50:36 AM

LAST REVISION 11/01/21	DESCRIPTION:		FY 2023-24 STANDARD PLANS	CURB AND GUTTER	INDEX	SHEET
			520-001		3 of 3	

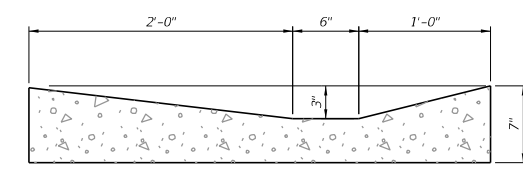
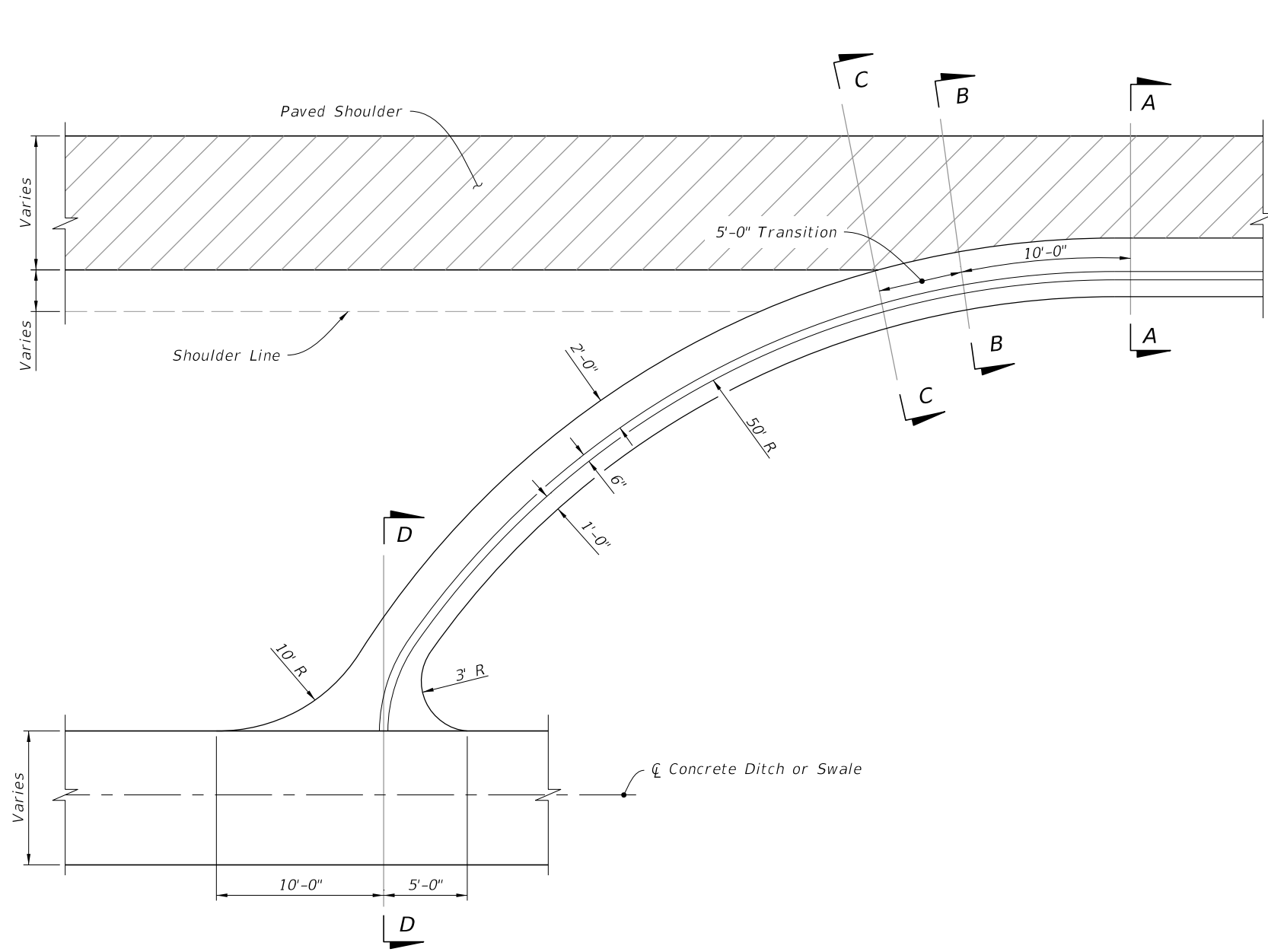

SECTION AA

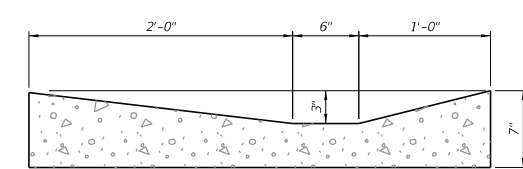

SECTION BB

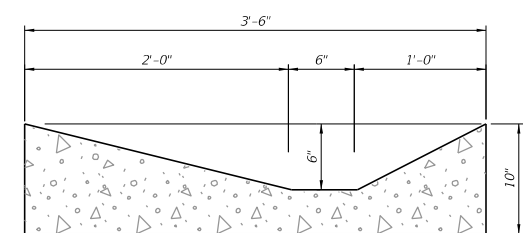

SECTION CC

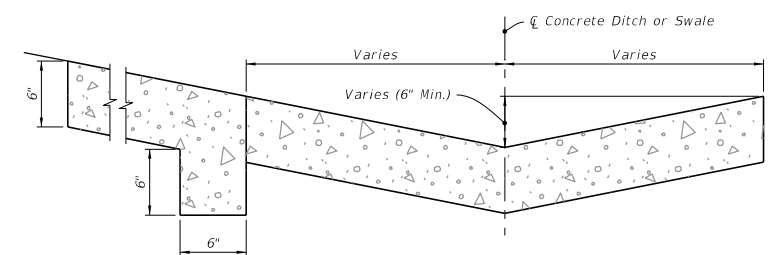

SECTION DD

CONCRETE SPILLWAY AT END OF SHOULDER GUTTER DETAILS

10/20/2022 8:50:39 AM

LAST REVISION 11/01/21	DESCRIPTION:	 FY 2023-24 STANDARD PLANS	CONCRETE SHOULDER GUTTER SPILLWAY	INDEX 520-005	SHEET 1 of 1
---------------------------	--------------	---	-----------------------------------	------------------	-----------------

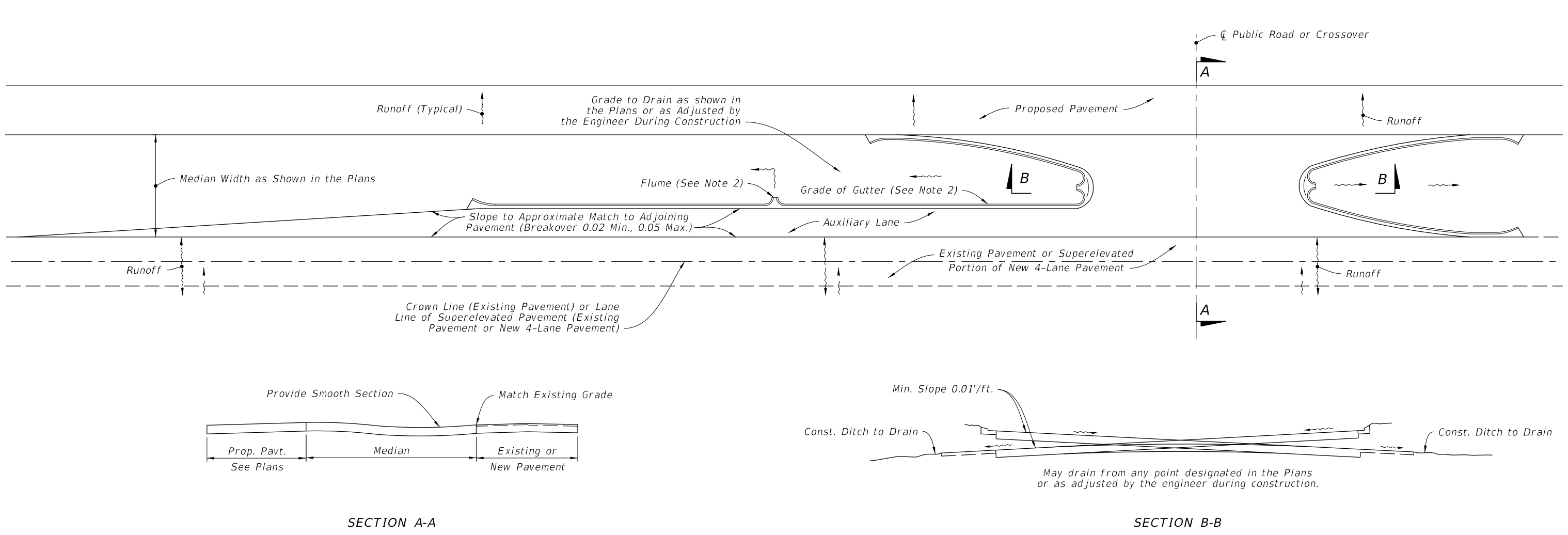

MEDIAN OPENING DETAIL

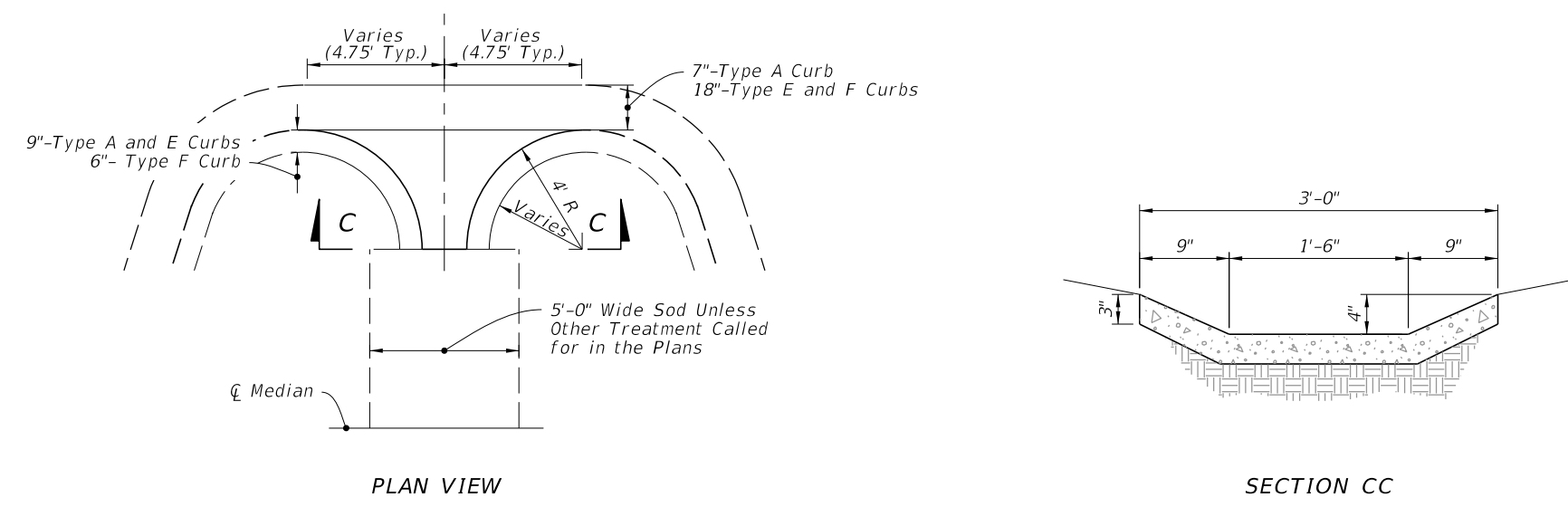

FLUME DETAIL

NOTES:

1. These details are to apply to projects which provide for the conversion of 2-lane sections to 4-lane divided highway sections and for superelevated sections of new 4-lane divided highways. Layout above is illustration only.
2. See Plans for flume length and location and grade of gutter. Flume locations may be adjusted by the Engineer during construction. If necessary to provide minimum gutter grade, warp surface of the median pavement within limits of the median curb or curb and gutter.

10/20/2022 8:50:39 AM

LAST REVISION 11/01/21	REVISION	DESCRIPTION:		FY 2023-24 STANDARD PLANS	MEDIAN OPENING FLUME	INDEX 520-010	SHEET 1 of 1
---------------------------	----------	--------------	--	------------------------------	----------------------	------------------	-----------------

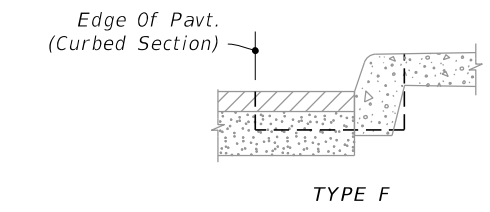
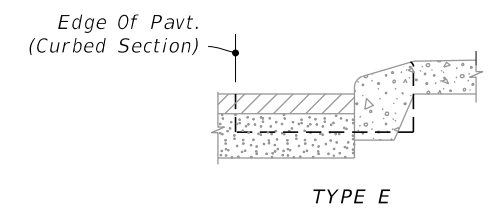
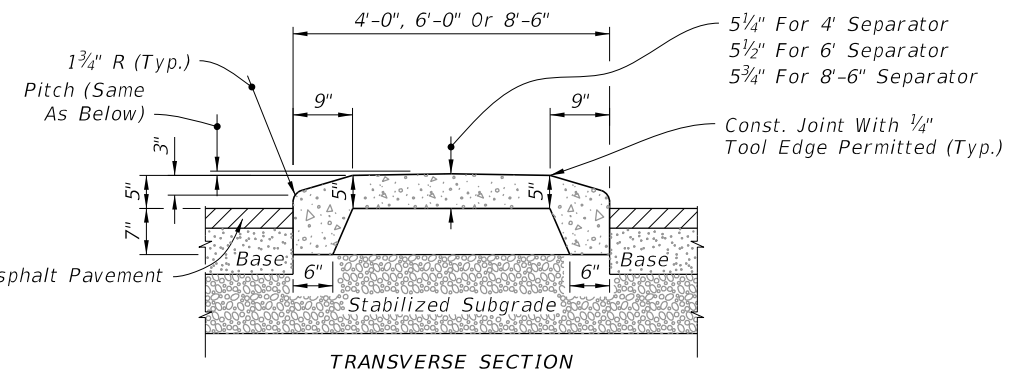
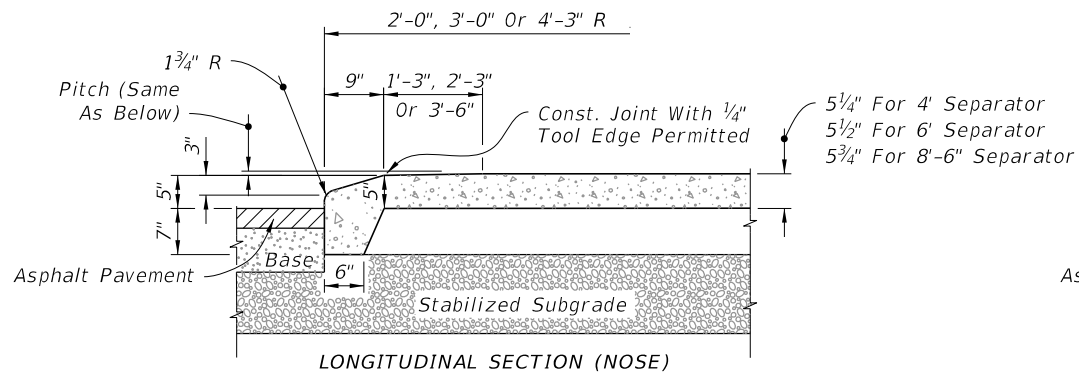

TYPE E

TYPE F

CURB AND GUTTER

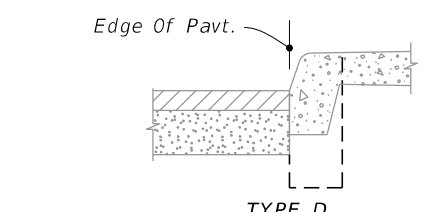
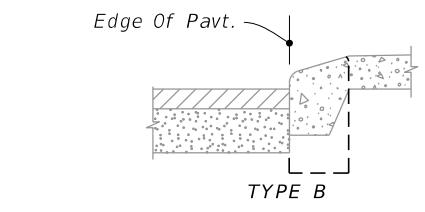
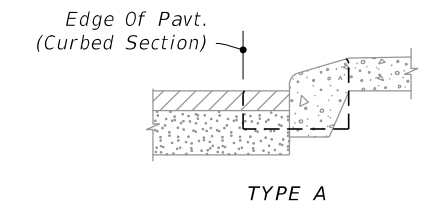

TYPE A

TYPE B

TYPE D

CURB

MEDIAN CURB AND TRAFFIC SEPARATOR JUNCTURE DETAILS

(Option I Separator Shown, For Curb Details see Index 520-001)

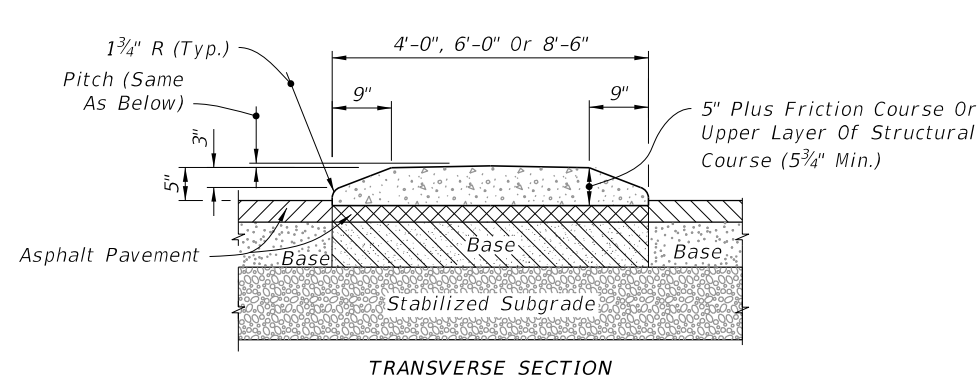
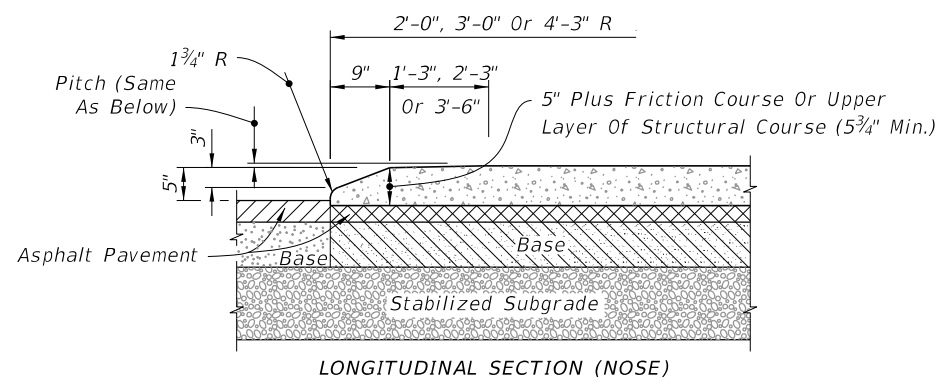

OPTION II

TYPE I - CONCRETE TRAFFIC SEPARATOR

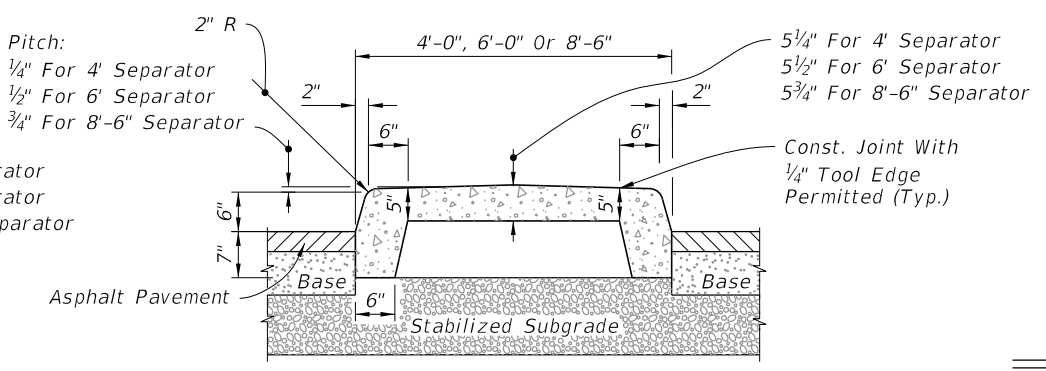
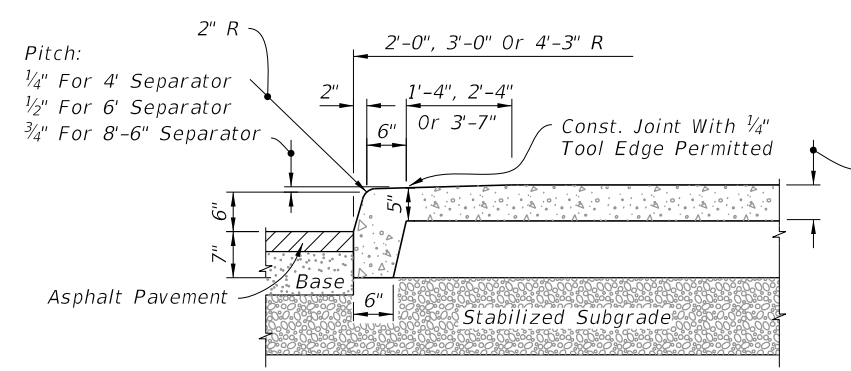

OPTION I

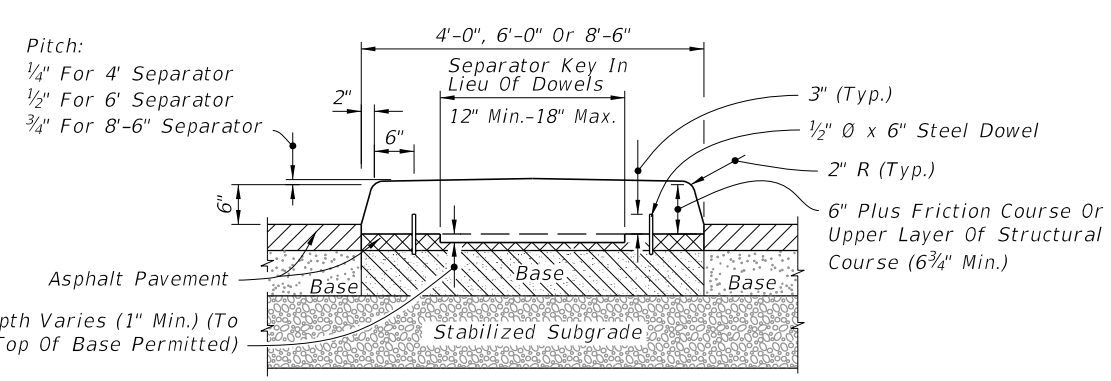
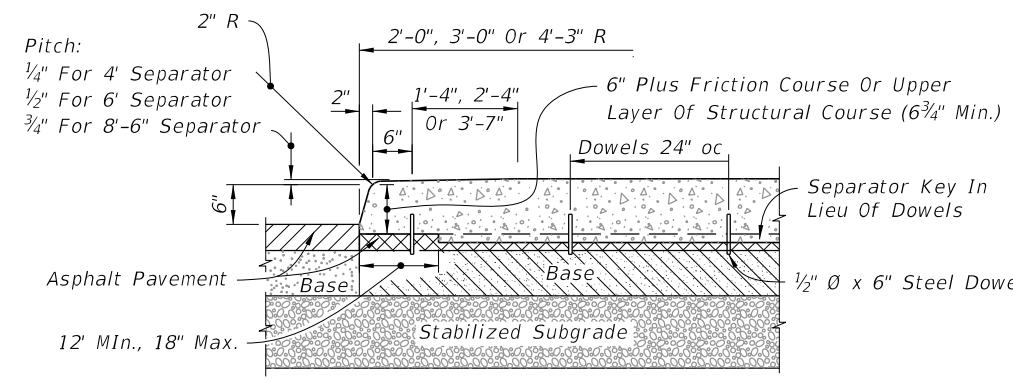

OPTION II

TYPE IV - CONCRETE TRAFFIC SEPARATOR

NOTES:

1. Separators Type I and IV are to be used with flexible pavement. Separators Types II and V are to be used with rigid pavement.
2. Either Option I or Option II may be used for Types I and IV separators except when a specific option is called for in the Plans.
3. For all separators provide 1/8"- 1/4" contraction joints at 10' centers (max.). Contraction joints adjacent to concrete pavement on tangents and flat curves to match the pavement joints, with intermediate joints not to exceed 10' center.

ROADWAY INSTALLATIONS - FLEXIBLE PAVEMENT

10/20/2022 8:50:40 AM

LAST REVISION 11/01/17	DESCRIPTION:		FY 2023-24 STANDARD PLANS	TRAFFIC SEPARATORS	INDEX	SHEET
					520-020	1 of 5

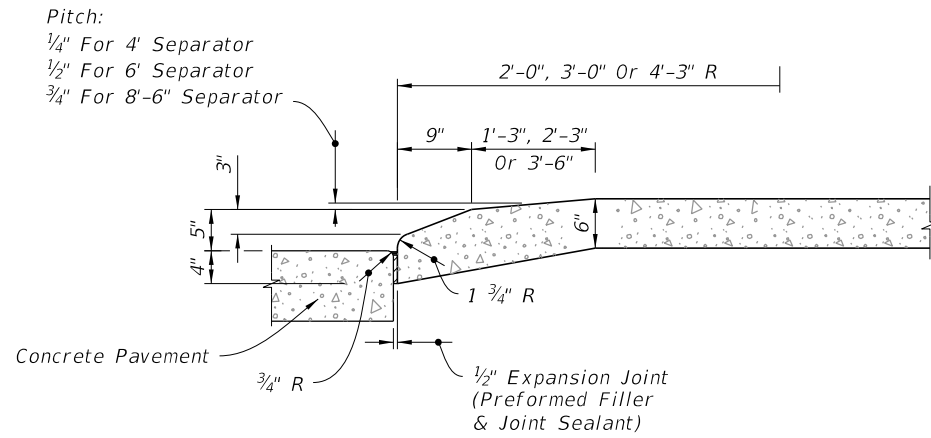

LONGITUDINAL SECTION (NOSE)

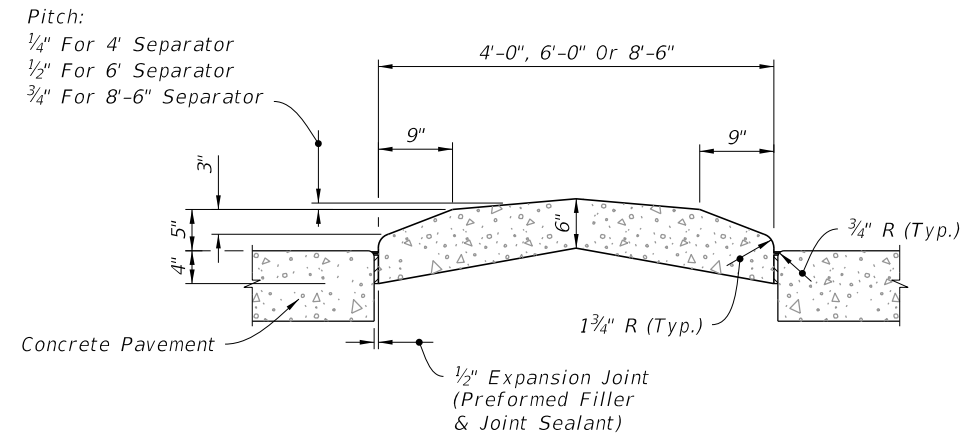

TRANSVERSE SECTION

TYPE II - CONCRETE TRAFFIC SEPARATOR

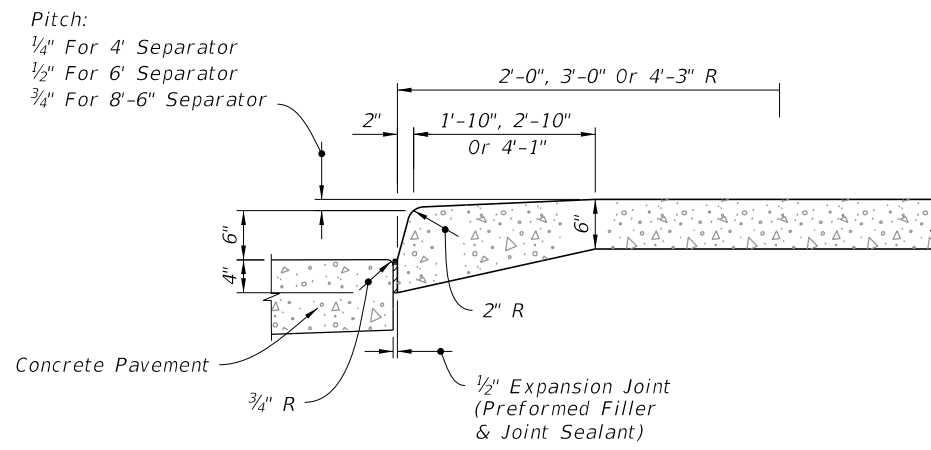

LONGITUDINAL SECTION (NOSE)

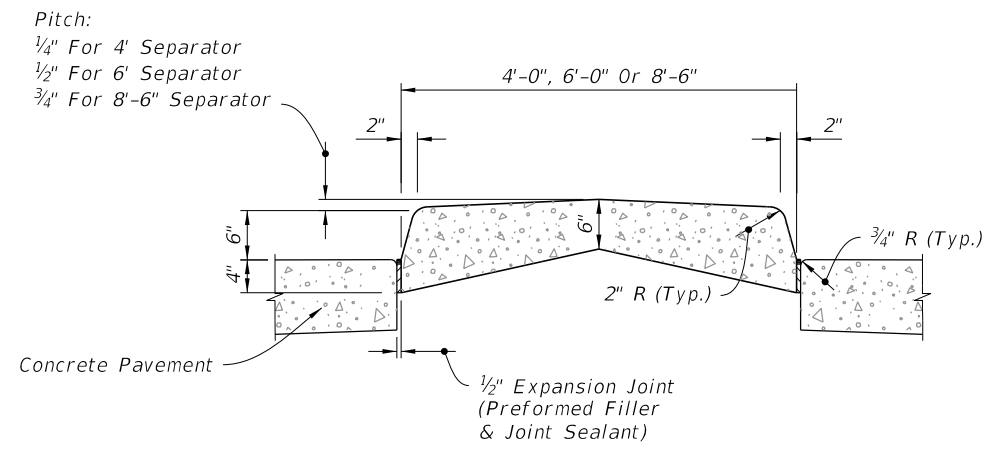

TRANSVERSE SECTION

TYPE V - CONCRETE TRAFFIC SEPARATOR

ROADWAY INSTALLATIONS - RIGID PAVEMENT

10/20/2022 8:50:41 AM

LAST REVISION 11/01/17	REVISION	DESCRIPTION:	 FY 2023-24 STANDARD PLANS	TRAFFIC SEPARATORS	INDEX 520-020	SHEET 2 of 5
---------------------------	----------	--------------	---	--------------------	------------------	-----------------

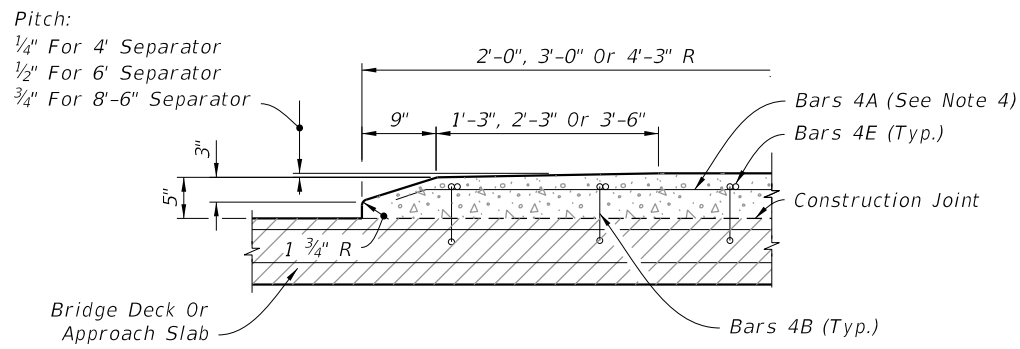

LONGITUDINAL SECTION (NOSE)

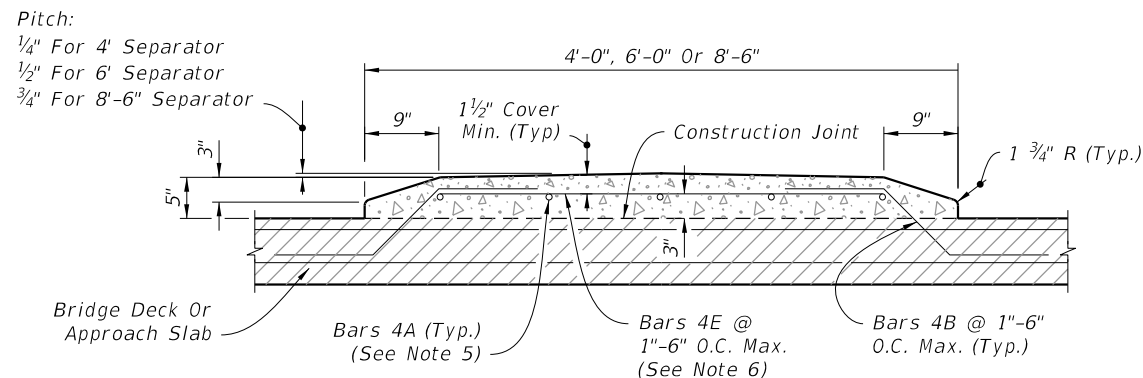

TRANSVERSE SECTION

OPTION I

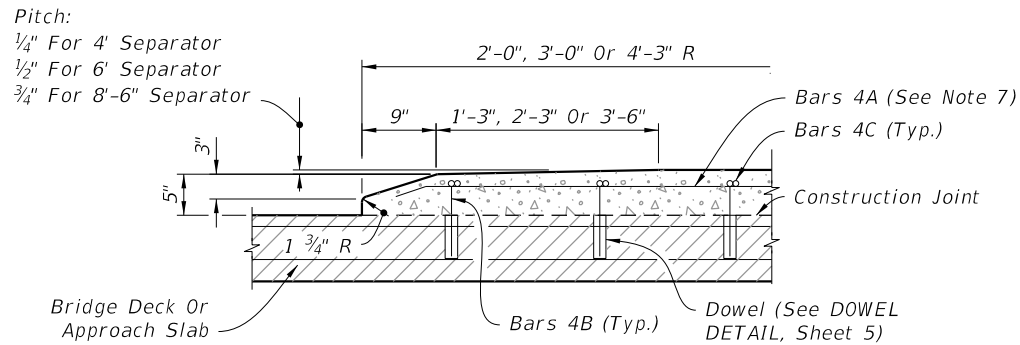

LONGITUDINAL SECTION (NOSE)

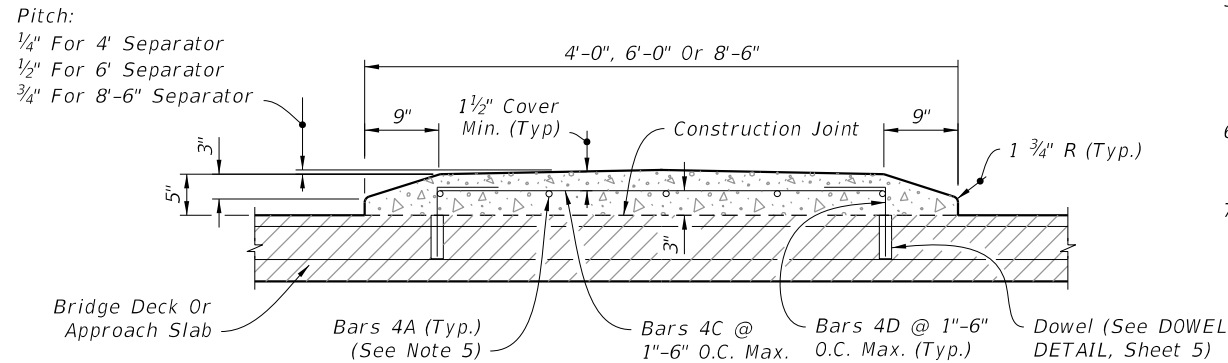

TRANSVERSE SECTION

OPTION II

NOTES:

1. Traffic Separator transverse reinforcement adjacent to deck expansion joints shall be field adjusted to maintain clearance and spacing. Bars shall be field cut as shown, bars may be rotated to maintain clearance.
2. Traffic Separator ends at deck expansion joints shall follow the deck joint limits. Drainage joints and b" V-Grooves shall be placed perpendicular or radial to the \bar{C} of the Traffic Separator. See Structures Plans, Superstructure and Approach Slab Sheets for details.
3. See Structures Plans, Superstructure Sheets for actual dimensions and joint orientation.
4. Option II is not permitted on bridge decks with prestressing steel.
5. Bar Spacing:
 4'-0" @ 3 equal spaces (continuous)
 6'-0" @ 5 equal spaces (continuous)
 8'-6" @ 7 equal spaces (continuous)
6. At the Contractor's option, a one piece bar may be substituted for Bars 4B and 4E.
7. Field bend and cut rebar as required to maintain cover.

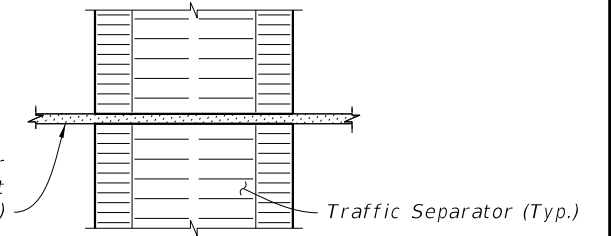

REINFORCING STEEL
(Bridge Deck SHOWN, Approach Slab Similar)

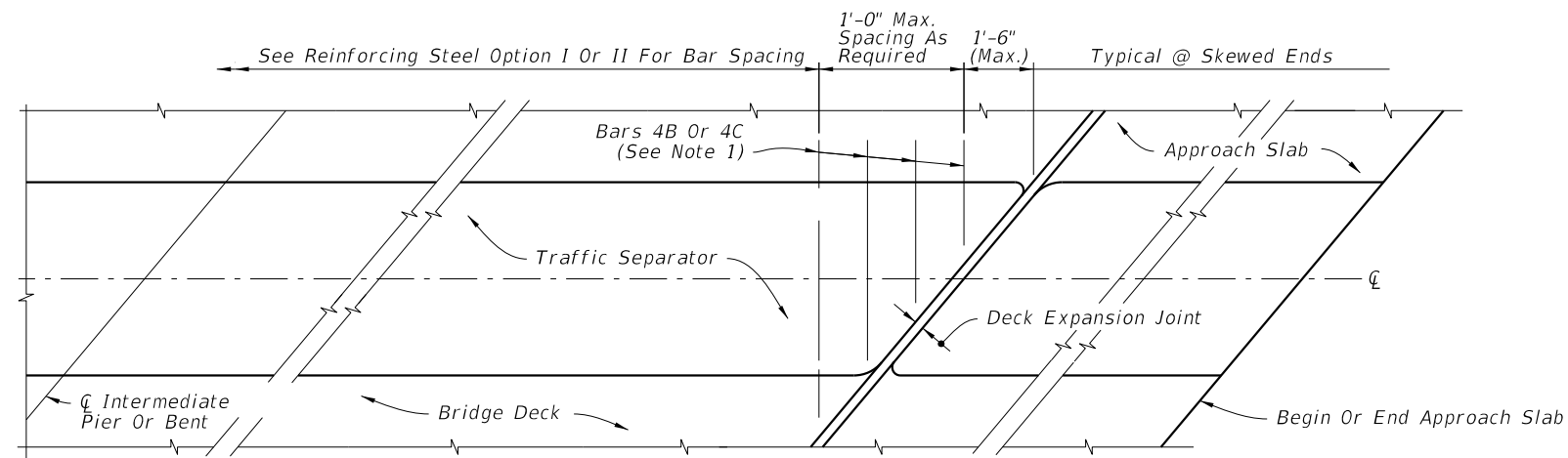

SKewed BRIDGE DECK AND APPROACH SLAB WITH TRAFFIC SEPARATOR
(Deck Expansion Joint at Begin or End Bridge Shown, Expansion Joint at \bar{C} Pier or Intermediate Bents Similar)

DETAIL AT Poured Joint With BACKER ROD EXPANSION JOINTS

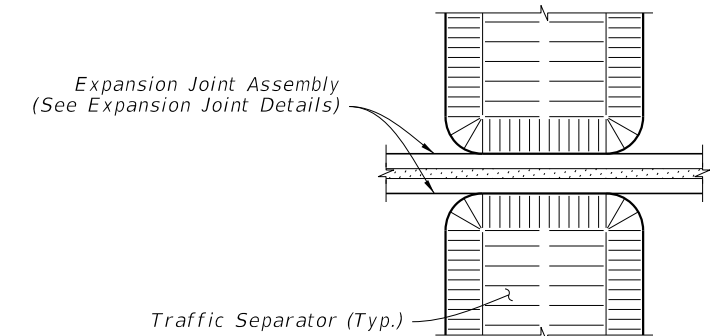

DETAIL AT EXPANSION JOINTS
(Strip Seal Shown, Other Armored Joint Types Similar)

BRIDGE INSTALLATIONS - TYPE "E" CURB

10/20/2022 8:50:42 AM

LAST REVISION 11/01/17	DESCRIPTION:
---------------------------	--------------

 FY 2023-24
 STANDARD PLANS

TRAFFIC SEPARATORS

INDEX 520-020	SHEET 3 of 5
------------------	-----------------

Pitch:
 1/4" For 4' Separator
 1/2" For 6' Separator
 3/4" For 8'-6" Separator

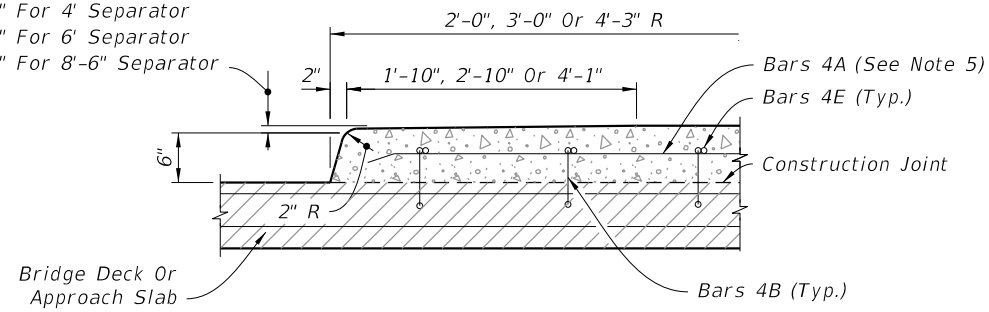

LONGITUDINAL SECTION (NOSE)

Pitch:
 1/4" For 4' Separator
 1/2" For 6' Separator
 3/4" For 8'-6" Separator

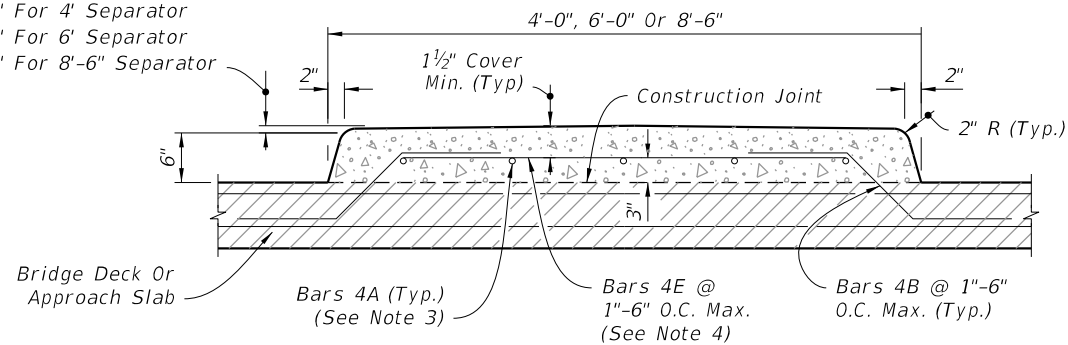

TRANSVERSE SECTION

OPTION I

Pitch:
 1/4" For 4' Separator
 1/2" For 6' Separator
 3/4" For 8'-6" Separator

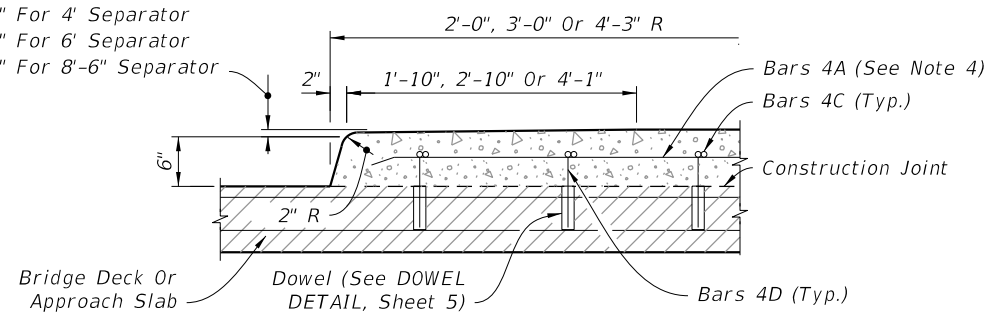

LONGITUDINAL SECTION (NOSE)

Pitch:
 1/4" For 4' Separator
 1/2" For 6' Separator
 3/4" For 8'-6" Separator

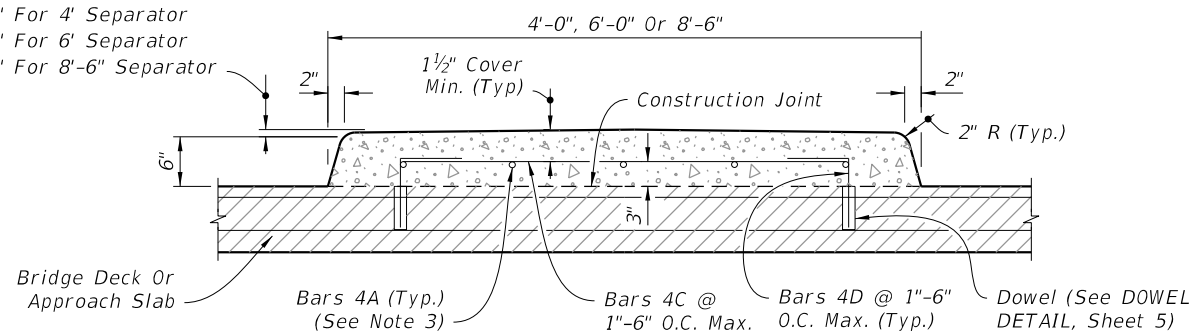

TRANSVERSE SECTION

OPTION II

REINFORCING STEEL

(Bridge Deck Shown, Approach Slab Similar)

Expansion Joint Assembly
 (See Expansion Joint Details)

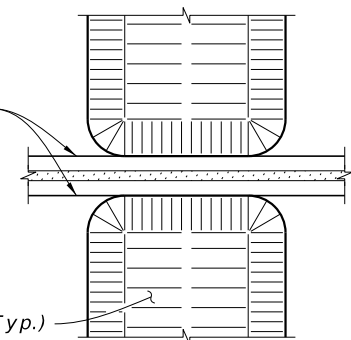

Traffic Separator (Typ.)

DETAIL AT EXPANSION JOINTS

(Strip Seal Shown, Other Armored Joint Types Similar)

Poured Joint With Backer
 Rod Expansion Joint
 (See Expansion Joint Details)

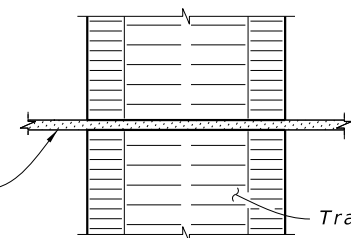

Traffic Separator (Typ.)

DETAIL AT POURED JOINT WITH
 BACKER ROD EXPANSION JOINTS

NOTES:

1. Treatment of separators on straight bridges shown. For additional notes and treatment of separators on skewed bridges, see Sheet 2.
2. Option II is not permitted on bridge decks with prestressing steel.
3. Bar Spacing:
 4'-0" @ 3 equal spaces (continuous)
 6'-0" @ 5 equal spaces (continuous)
 8'-6" @ 7 equal spaces (continuous)
4. At the Contractor's option, a one piece bar may be substituted for Bars 4B and 4E.
5. Field bend and cut rebar as required to maintain cover.

10/20/2022 8:50:43 AM

LAST REVISION 11/01/17	REVISION	DESCRIPTION:
---------------------------	----------	--------------



FY 2023-24
 STANDARD PLANS

TRAFFIC SEPARATORS

INDEX
 520-020

SHEET
 4 of 5

BRIDGE INSTALLATIONS - TYPE "F" CURB

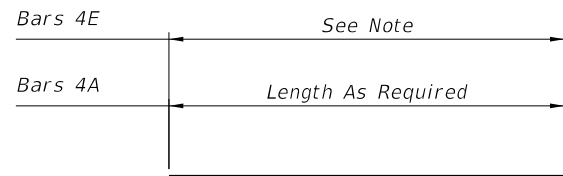

Bars 4A & 4E

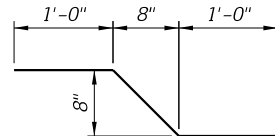

Bar 4B

NOTE:

Length of Bars 4E is 2'-5" for 4'-0" Separator.
 Length of Bars 4E is 4'-5" for 6'-0" Separator.
 Length of Bars 4E is 6'-11" for 8'-6" Separator.

OPTION I

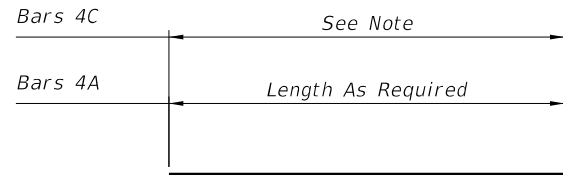

Bars 4A & 4C

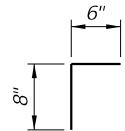

Bar 4D

NOTE:

Length of Bars 4C is 2'-4½" for 4'-0" Separator.
 Length of Bars 4C is 4'-4½" for 6'-0" Separator.
 Length of Bars 4C is 6'-10½" for 8'-6" Separator.

OPTION II

REINFORCING STEEL NOTES:

- All dimensions are out to out.
- The 8" vertical dimension shown for Bars 4B and 4D are based on a slab 8½" thick or greater without a wearing surface. If slab thickness is less than 8½", decrease this dimension by an amount equal to the difference in thickness. If a wearing surface is to be provided, increase this dimension by an amount equal to the wearing surface thickness.

CONVENTIONAL REINFORCING STEEL BENDING DIAGRAMS

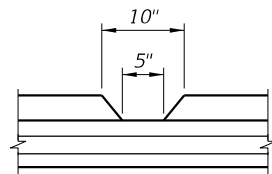

See Structures Plans, Superstructure Sheets for location(s) of drainage joints. Locations for drainage joints shall be limited to the constant width section of separator.

DRAINAGE JOINT DETAIL
(For 5" Opening Or Less)

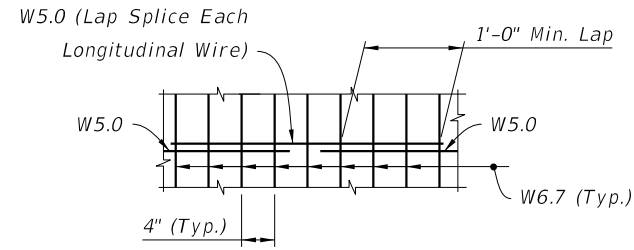

SPLICE DETAIL
(Between WWR 3 x 4 - W5.0 x W6.7 Sections)

OPTION A: Use Welded Wire Reinforcement 3 x 4 - W5.0 x W6.7 as required by plans in place of Bars 4A, 4B and 4E. Bend the Welded Wire Reinforcement to the dimensions of Bar 4B shown in the Bending Diagram for Reinforcing Steel Option I.

OPTION B: Use Welded Wire Reinforcement 3 x 4 - W5.0 x W6.7 as required by plans in place of Bars 4A and 4C shown in Reinforcing Steel Option II.

NOTE: Welded Wire Reinforcement to consist of smooth wire meeting the requirements of Specification 931.

ALTERNATE REINFORCING STEEL DETAILS
(Welded Wire Reinforcement)

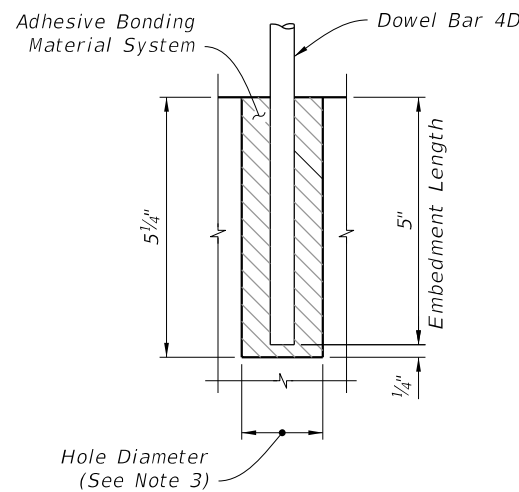

DOWEL NOTES:

- Shift Dowel Holes to clear if existing reinforcement is encountered.
- Provide and install an adhesive bonding material system in accordance with Specifications 416 and 937.
- The dowel hole diameter is to meet adhesive bonding material system manufacturer's requirements.

DOWEL DETAIL

ESTIMATED TRAFFIC SEPARATOR QUANTITIES:

CONCRETE:

CONSTANT WIDTH OF SEPARATOR:

	TYPE "E"	TYPE "F"
4'-0" Width	0.056 CY per Ft.	0.072 CY per Ft.
6'-0" Width	0.089 CY per Ft.	0.112 CY per Ft.
8'-6" Width	0.132 CY per Ft.	0.164 CY per Ft.

NOSE:

	TYPE "E"	TYPE "F"
4'-0" Width	0.080 CY	0.109 CY
6'-0" Width	0.193 CY	0.257 CY
8'-6" Width	0.403 CY	0.536 CY

REINFORCING STEEL:

(All quantities are based on an 8½" slab.)

OPTION I:

4'-0" Width	6.37 Lbs. per Ft.
6'-0" Width	8.60 Lbs. per Ft.
8'-6" Width	11.05 Lbs. per Ft.

OPTION II:

4'-0" Width	4.77 Lbs. per Ft.
6'-0" Width	7.00 Lbs. per Ft.
8'-6" Width	9.45 Lbs. per Ft.

BRIDGE INSTALLATIONS - TYPE "E" AND "F" CURB

10/20/2022 8:50:44 AM

LAST REVISION	DESCRIPTION:
11/01/17	



FY 2023-24
STANDARD PLANS

TRAFFIC SEPARATORS

INDEX
520-020

SHEET
5 of 5

SHEET	CONTENTS
1	Index Contents; General Notes
2	Median Barrier
3	Median Barrier - Reinforcing Details
4	Median Barrier - Sloped End Treatment
5	Median Barrier - Grade Separated
6	Median Barrier - 56" Height Section for Barrier-Mounted Sign Support Shielding - Symmetrical
7	Median Barrier - 56" Height Section for Barrier-Mounted Sign Support Shielding - Asymmetrical
8	Median Barrier - 56" Height Section for Barrier-Mounted Dual Sign Support Shielding - Min. Width
9	Median Barrier - 38" Height Split Section for Stand-Alone Sign Support Shielding
10	Median Barrier - 44" Height Split Section for Pier Shielding
11	Median Barrier - 44" Height Split Section for Pier Shielding - Details
12	Median Barrier - Connection to F-Shape
13	Shoulder Barrier
14	Shoulder Barrier - Reinforcing Details
15	Shoulder Barrier - Section Options
16	Shoulder Barrier - Section Options (Continued), Drainage Slot Option
17	Shoulder Barrier - 38" Height Rear-Flush Section for Reduced Setback Pier Shielding (Low-Speed)
18	Shoulder Barrier - 44" Height Rear-Flush Section for Reduced Setback Pier Shielding
19	Shoulder Barrier - Connection to F-Shape
20	Curb and Gutter Barrier
21	Curb and Gutter Barrier - Reinforcing Details
22	Curb and Gutter Barrier - Sloped End Treatment
23	Wall Shielding Barrier - 38" Height Section - Approach and Trailing Transition
24	Wall Shielding Barrier - 38" Height Section - Guardrail Connection
25	Wall Shielding Barrier - 56" Height Section for Barrier-Mounted Sign Support Shielding
26	Reinforcing Bar Bending Diagrams

GENERAL NOTES:

- BARRIER CONCRETE:** Use Class II concrete for all barriers constructed in slightly aggressive environments, and use Class IV Concrete for all barriers constructed in moderately or extremely aggressive environments. On all exposed surfaces, apply a General Surface Finish in accordance with Specification 400.
- STEEL BAR REINFORCEMENT:** Where required to maintain continuity, provide lap splices of at least 18 inches for No. 4 bars and 20 inches for No. 5 bars, unless otherwise shown herein (including shorter splices as provided by the default bar bending diagrams).

The default reinforcing details shown herein, including bar shapes and lap splice positions, are intended to show required steel locations and provide for a constructible design. However, with the approval of the Engineer, alternate steel configurations may be used in the same locations shown herein, given that the equivalent strength reinforcing is provided and the cover, maximum spacing, and continuity requirements are maintained.
- OPTIONAL WELDED WIRE REINFORCEMENT:** With the approval of the Engineer, steel welded wire reinforcement in accordance with Specification 415 may be substituted for the steel bars shown herein. Place the welded wire in the same locations specified for the steel bars, and maintain the equivalent strength, cover, maximum spacing, and continuity requirements.

GENERAL NOTES (CONTINUED):

- TOP FACE LONGITUDINAL REINFORCEMENT:** Unless otherwise specified, the longitudinal reinforcement shown closest to the top face of the barrier has a maximum cover of 4½", measured from the top face of the barrier.
- MINIMUM BARRIER LENGTH:** Unless otherwise shown in the Plans, the minimum Concrete Barrier length is 40 feet.
- CONSTRUCTION JOINTS:** Install Construction Joints only as needed for discontinuous concrete casting or cold joints. Maintain continuity of steel reinforcement across Construction Joints. Construction Joints are classified herein as Transverse Joints or Longitudinal Joints.

Transverse Joints are permitted at 20-foot or greater intervals along the barrier. For Tall Grade-Separated Sections, see Sheet 5 for additional Transverse Joint requirements.

Longitudinal Joints are only permitted where indicated in the following details and notes, with a vertical position tolerance of ± 1½" from the locations shown.
- DOWELED JOINTS:** As shown in the Dowel Details on Sheets 2 & 13, install ¾" Doweled Joints for Concrete Barrier connections to Wall Coping Barriers, Pier Protection Barriers, and Traffic Railings. Doweled Joints are also required for expansion mitigation in Median Barrier as defined per Sheets 2 & 5. Doweled Joints are not permitted within Grade-Separated Median Barrier.
- CRACK CONTROL V-GROOVES:** At 20-foot intervals, place ¾" depth V-grooves that run vertically and/or transversely in the front, top, and back faces of barriers. The V-grooves can be either molded or scored while the concrete is still plastic.
- SUBGRADE:** Compact the top layer of subgrade with Type B Stabilization, LBR 40 (12 in.).
- FOOTING BOTTOM CONCRETE COVER:** At the bottom of barrier footings shown throughout this Index, up to 2 inches of additional concrete cover is permitted beyond what is shown herein to accommodate soil grade irregularities.
- FINISH GRADE ELEVATION:** At the barrier face location, the finish grade pavement has a vertical position tolerance of ± ½" from the nominal locations shown herein, relative to the barrier elevation. Maintain visually smooth and even pavement at the barrier face, per the approval of the Engineer.
- DRAINAGE INLETS:** Where called for in the Plans, install corresponding inlets per Indexes 425-030 thru 425-032.
- LIGHT POLE MOUNTING:** Where called for in the Plans, install aluminum light poles per Index 715-002.
- OPAQUE VISUAL BARRIER:** Where called for in the Plans, install Opaque Visual Barrier per Index 521-010.
- BARRIER END MARKERS:** For all free ends of concrete barriers that are not shielded with an end treatment or connection to another barrier or traffic railing type, install a Type 3 Object Marker on the end face per Specification 705.
- BARRIER DELINEATORS:** Install Barrier Delineators in accordance with Specification 705. For median barriers, mount the delineator on the top of the barrier, at the centerline of barrier, with reflective sheeting facing traffic on both approaches. For shoulder barriers and split sections, mount the delineators on the top of the barrier, with the roadway side of the delineator located 2" from the front face of the barrier and the reflective sheeting facing traffic of the nearest approach.
- TOLL SITES:** Where called for in the Plans, substitute the steel reinforcing bars shown herein with GFRP reinforcing bars of the same size. Construct GFRP reinforcing bars in accordance with Specification 932, and use a maximum 4½" inner diameter for bar bends. Alternative bar bending details and shapes may be used so long as the final location of the reinforcing is unchanged and the bars are either continuous or fully spliced at the side and bottom barrier locations. Where required to fit pull boxes while maintaining bar spacing and concrete cover, trim GFRP bars as defined in the Plans.

At toll site locations, the use of Median Barriers on outside shoulders is permitted where called for in the Plans. Shoulder Pavement shown herein may be substituted with material for an alternate usage where defined in the Plans.

10/20/2022 8:50:46 AM

LAST REVISION 11/01/22	REVISION	DESCRIPTION:	 FY 2023-24 STANDARD PLANS	CONCRETE BARRIER	INDEX 521-001	SHEET 1 of 26
---------------------------	----------	--------------	---	-------------------------	------------------	------------------

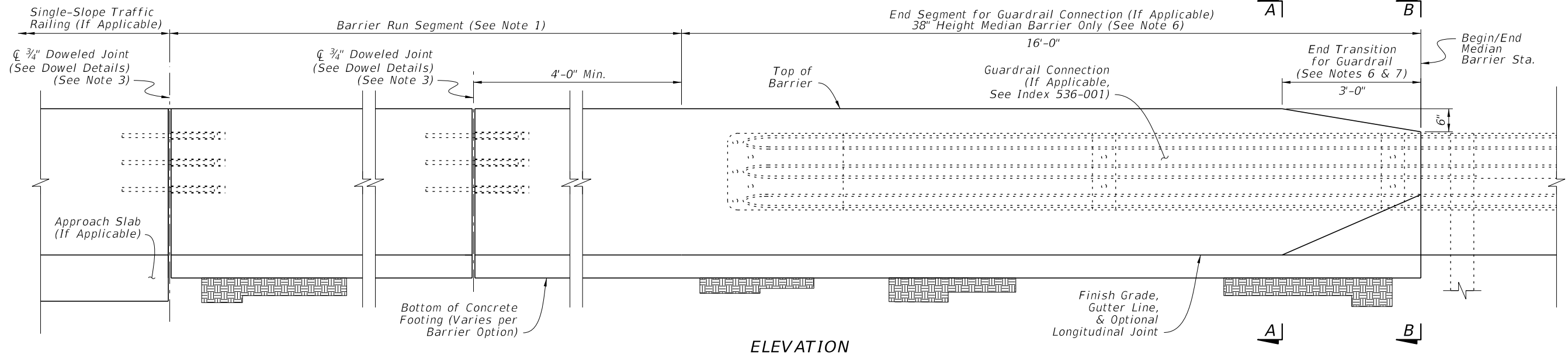

ELEVATION

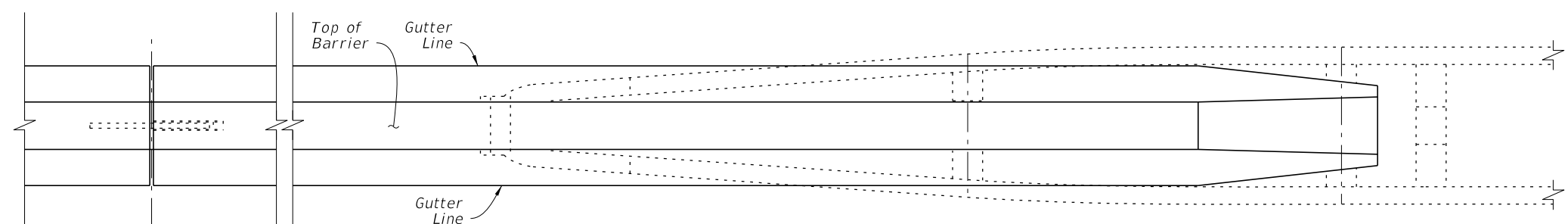

PLAN

MEDIAN BARRIER NOTES:

- BARRIER RUN SEGMENT:** Within the Barrier Run Segment, either the 38" Height Median Barrier or the differing Median Barrier sections shown throughout the Index may be placed as required per the Plans.
- SECTION VIEWS:** For additional Views A-A and B-B, see Sheet 3.
- DOWELED JOINTS:** See the General Notes on Sheet 1 for usage of joint types. Place Doweled Joints at 100-foot maximum intervals. Place steel reinforcing with a longitudinal 3" cover adjacent to the joint face(s) in the barrier. Use ASTM A36 smooth round bars with hot-dip galvanization.

For the dowel connection into the first casting, the dowel may be cast-in-place for new concrete or placed into a 1 1/8" O x 13" (± 1/2") drilled hole for cured concrete. For drilled holes larger than 1 1/8" O, secure the dowel with adhesive in accordance with Specification 416. No load testing is required.

For the dowel connection into the second casting, use a 1 1/4" NPS Schedule 80 PVC pipe with a sealed cap, cast-in-place as shown.
- OPTIONAL LONGITUDINAL JOINT:** When a longitudinal joint is placed above the footing, use the Optional 1 1/2" x 5 1/2" Shear Key shown. As a substitute for the Shear Key, the concrete footing's top surface may be raked to provide additional shear friction. Rake the fresh concrete surface so that about half of the surface area consists of approximately 1/4" depth longitudinal grooves, distributed evenly and approved by the Engineer.
- MINOR GRADE SEPARATIONS:** Where called for in the Plans, the nominal shoulder pavement surface elevation may be placed up to 2" below the location shown herein on one side of the barrier. For barriers with shallow embedments shown on Sheets 6 thru 9, extend the barrier's concrete lower across its entire section such that the barrier's concrete bottom remains embedded at least 1" below the lowered pavement surface.
- GUARDRAIL CONNECTIONS:** Connect Guardrail using the Transition Connections to Rigid Barrier per Index 536-001 in conjunction with the 16'-0" End Segment for Guardrail shown herein.
- CRASH CUSHION CONNECTIONS:** Connect Crash Cushions per Index 544-001 in conjunction with the 3'-0" End Transition for Guardrail as shown herein.
- FREE ENDS:** When the barrier end does not terminate with a Traffic Railing Connection, Guardrail Connection, Crash Cushion Connection, or Sloped End Treatment as called for in the Plans, terminate in accordance with the Free End Reinforcing detail on Sheet 3.

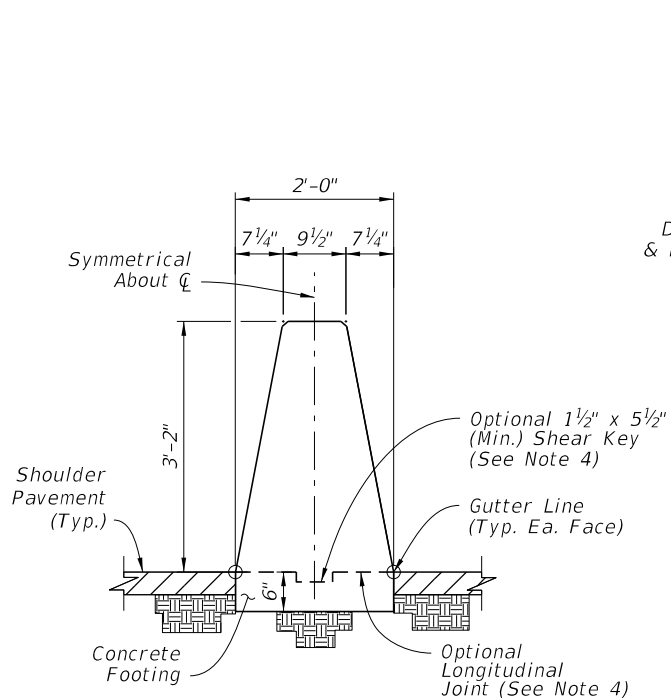

SECTION A-A
38" HEIGHT MEDIAN BARRIER
(See Sheet 3 for Steel Reinforcing Details)

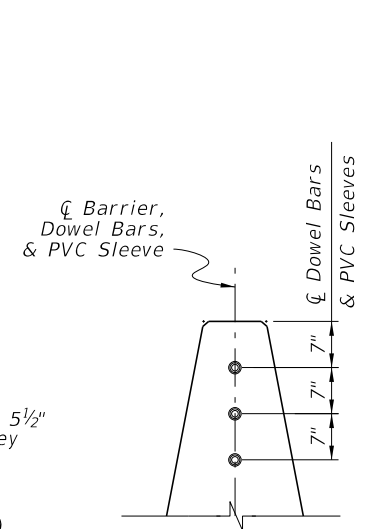

SECTION DOWEL PLACEMENT

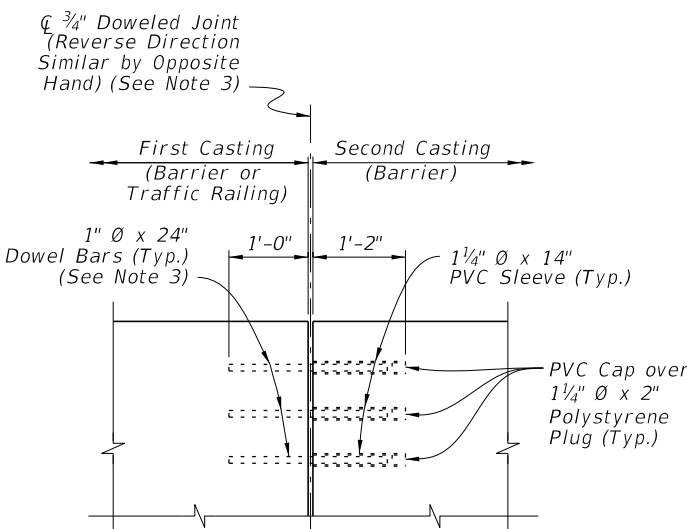

ELEVATION DOWEL BAR & PVC CONNECTION

DOWEL DETAILS

10/20/2022 8:50:46 AM

LAST REVISION 11/01/22	REVISION	DESCRIPTION:		FY 2023-24 STANDARD PLANS	CONCRETE BARRIER	INDEX	SHEET
						521-001	2 of 26

MEDIAN BARRIER

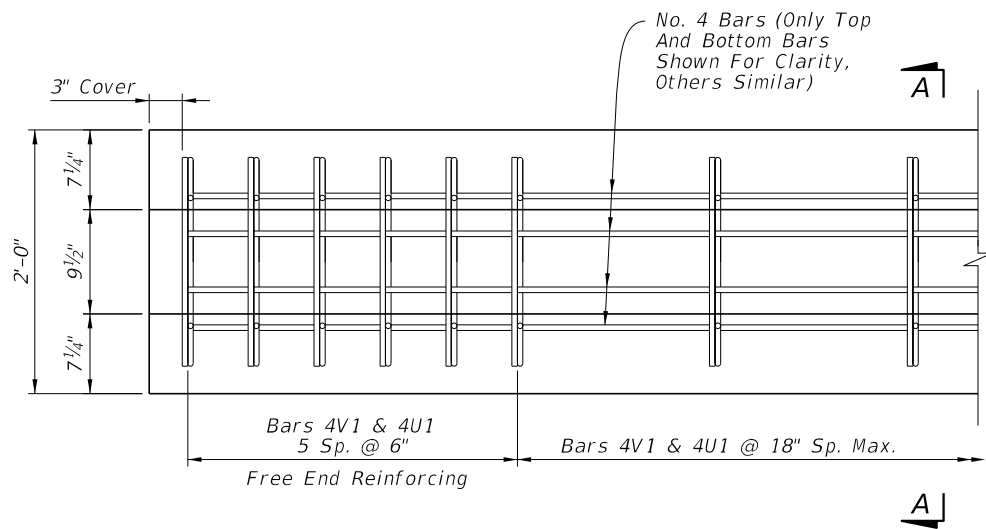

PLAN VIEW - 38" HEIGHT MEDIAN BARRIER
FREE END REINFORCING (See Note 3)

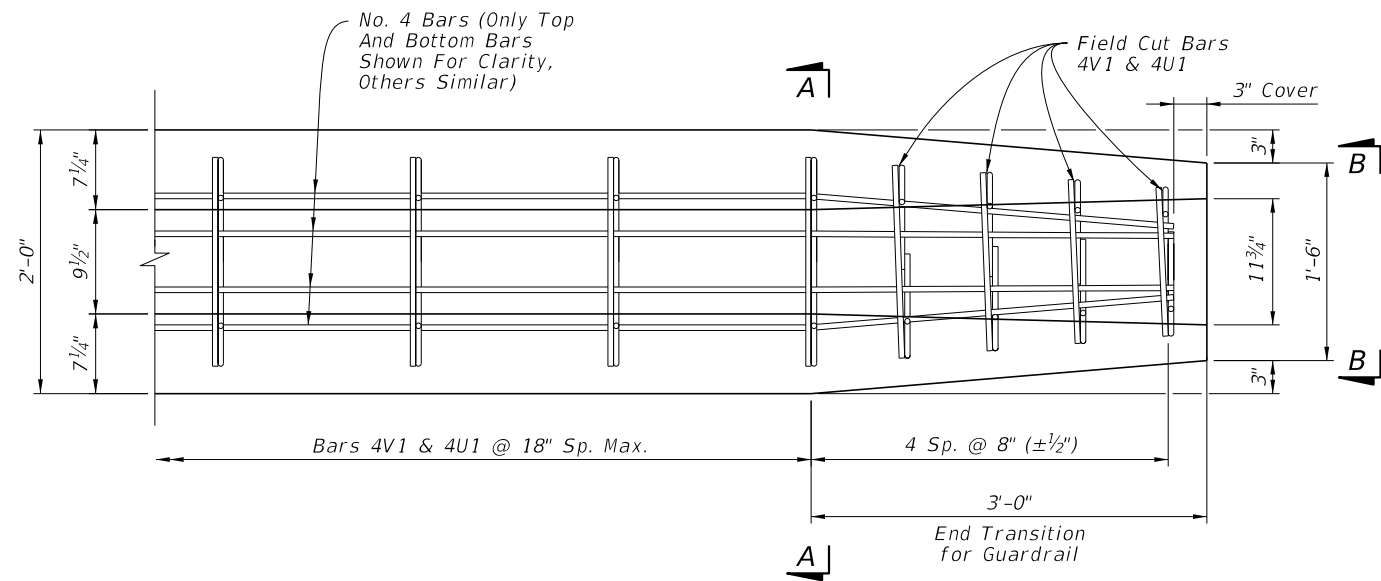

PLAN VIEW - END SEGMENT FOR
GUARDRAIL CONNECTION (See Note 3)

NOTES:

1. GENERAL: Work with the Plan and Elevation Views on Sheet 2.
2. BAR BENDING DIAGRAMS: For additional information on Bars 4V1 and 4U1, see the details on Sheet 26.
3. PLAN VIEWS: Only top and bottom longitudinal reinforcing is shown for clarity. For all longitudinal steel locations, see the section views.

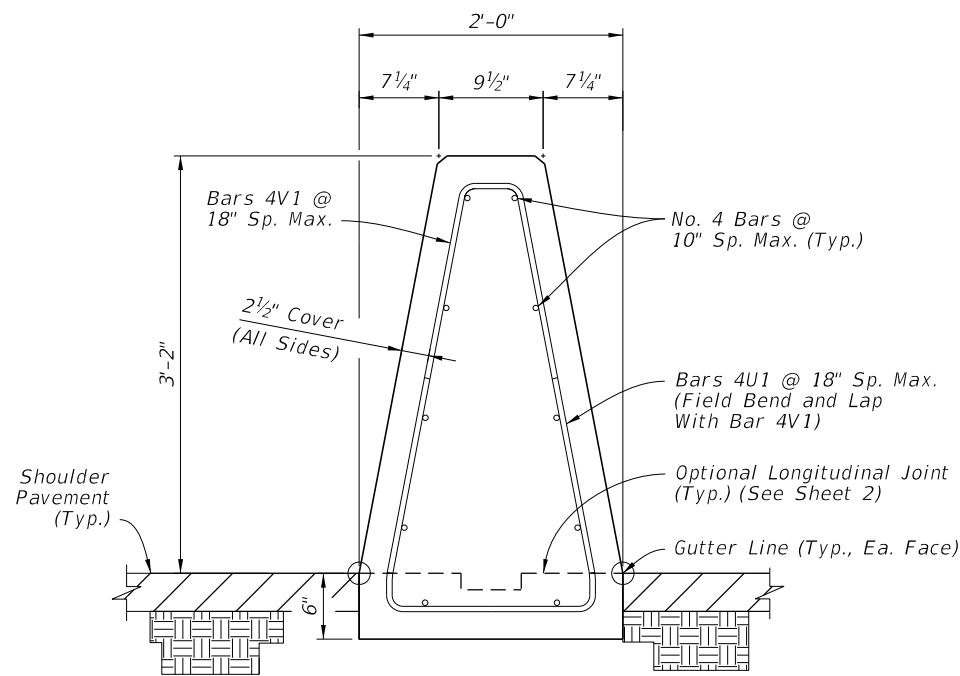

SECTION A-A
38" HEIGHT
MEDIAN BARRIER

Concrete Qty. = 0.20 CY/FT
Steel Qty. = 11.8 LB/FT

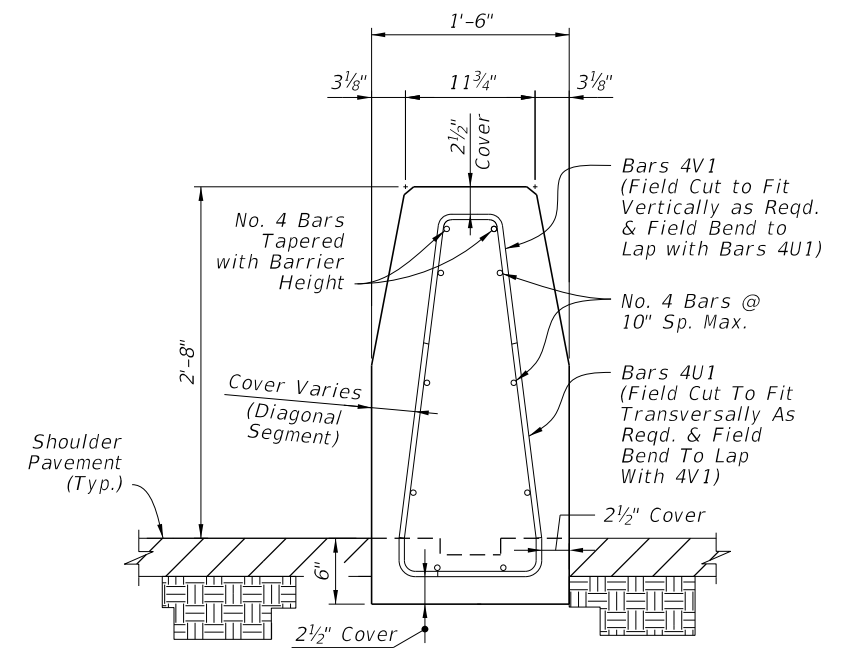

VIEW B-B
REDUCED SECTION
FOR GUARDRAIL
END OF BARRIER

MEDIAN BARRIER - REINFORCING DETAILS

10/20/2022 8:50:47 AM

LAST REVISION 11/01/20	REVISION	DESCRIPTION:	 FY 2023-24 STANDARD PLANS	CONCRETE BARRIER	INDEX 521-001	SHEET 3 of 26
---------------------------	----------	--------------	--	------------------	------------------	------------------

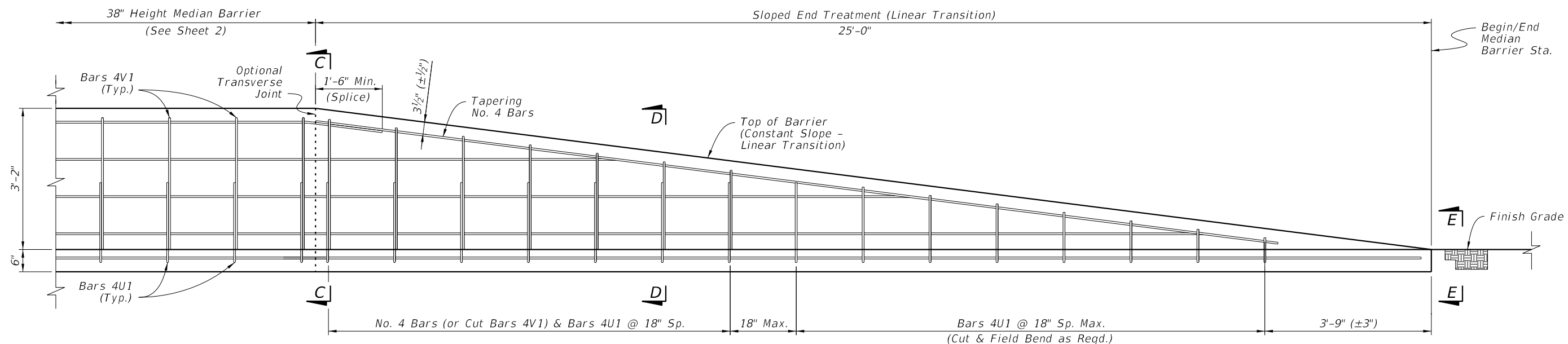

ELEVATION - SLOPED END TREATMENT

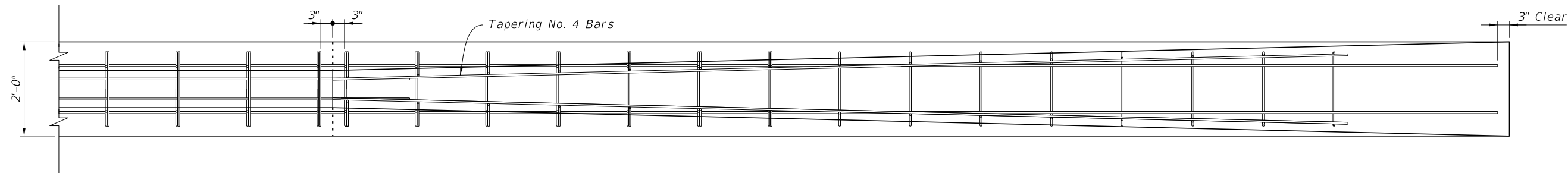

PLAN - SLOPED END TREATMENT
(Only Top & Bottom Longitudinal Bars Shown for Clarity,
See Section Views for All Longitudinal Steel Locations)

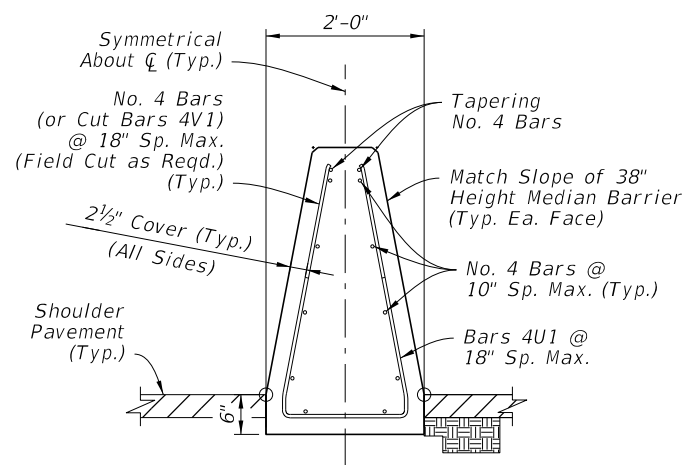

SECTION C-C
BEGIN TRANSITION
REINFORCING
(Height Varies Linearly
per Elevation View)

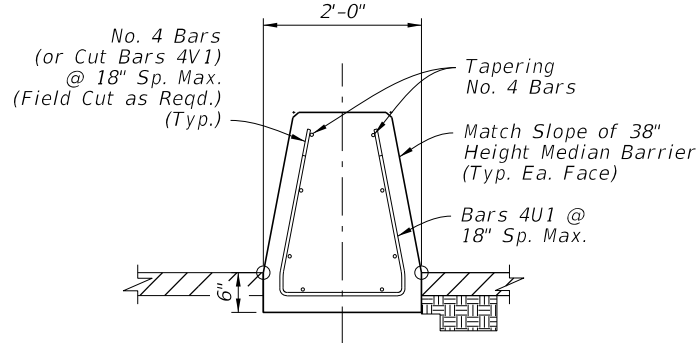

SECTION D-D
INTERMEDIATE TRANSITION
REINFORCING
(Height Varies Linearly
per Elevation View)

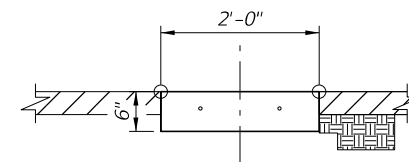

VIEW E-E
END TRANSITION

NOTES:

1. GENERAL: Install Sloped End Treatment only where called for in the plans.
2. JOINTS: Construction or Doweled Joints are not permitted within the Sloped End Treatment segment.

MEDIAN BARRIER - SLOPED END TREATMENT

10/20/2022 8:50:48 AM

LAST REVISION 11/01/18	REVISION	DESCRIPTION:
---------------------------	----------	--------------



FY 2023-24
STANDARD PLANS

CONCRETE BARRIER

INDEX
521-001

SHEET
4 of 26

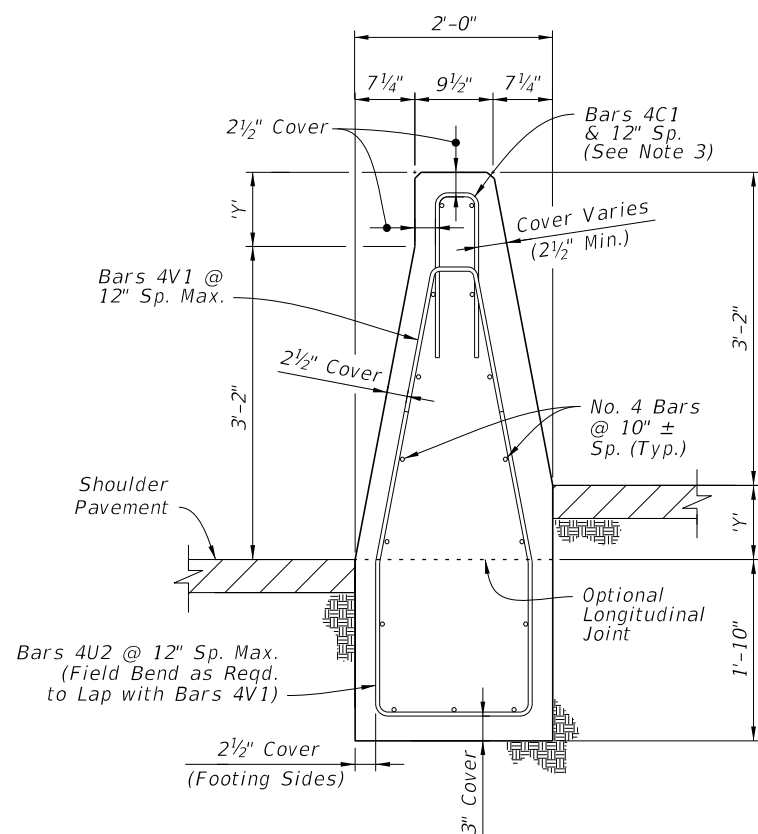

SHORT GRADE-SEPARATED SECTION FOR $Y \leq 9"$

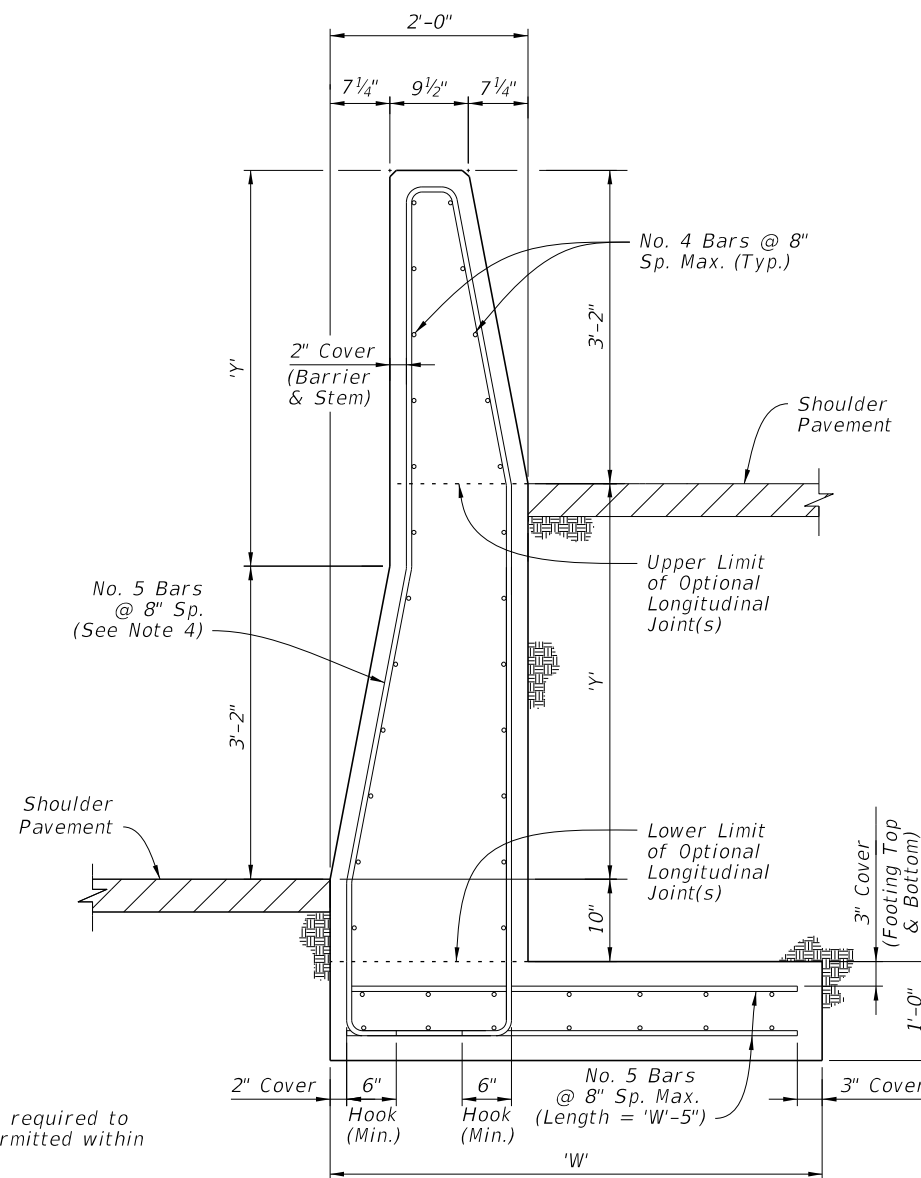

TALL GRADE-SEPARATED HEEL FOOTING SECTION FOR $Y \leq 4'-0"$

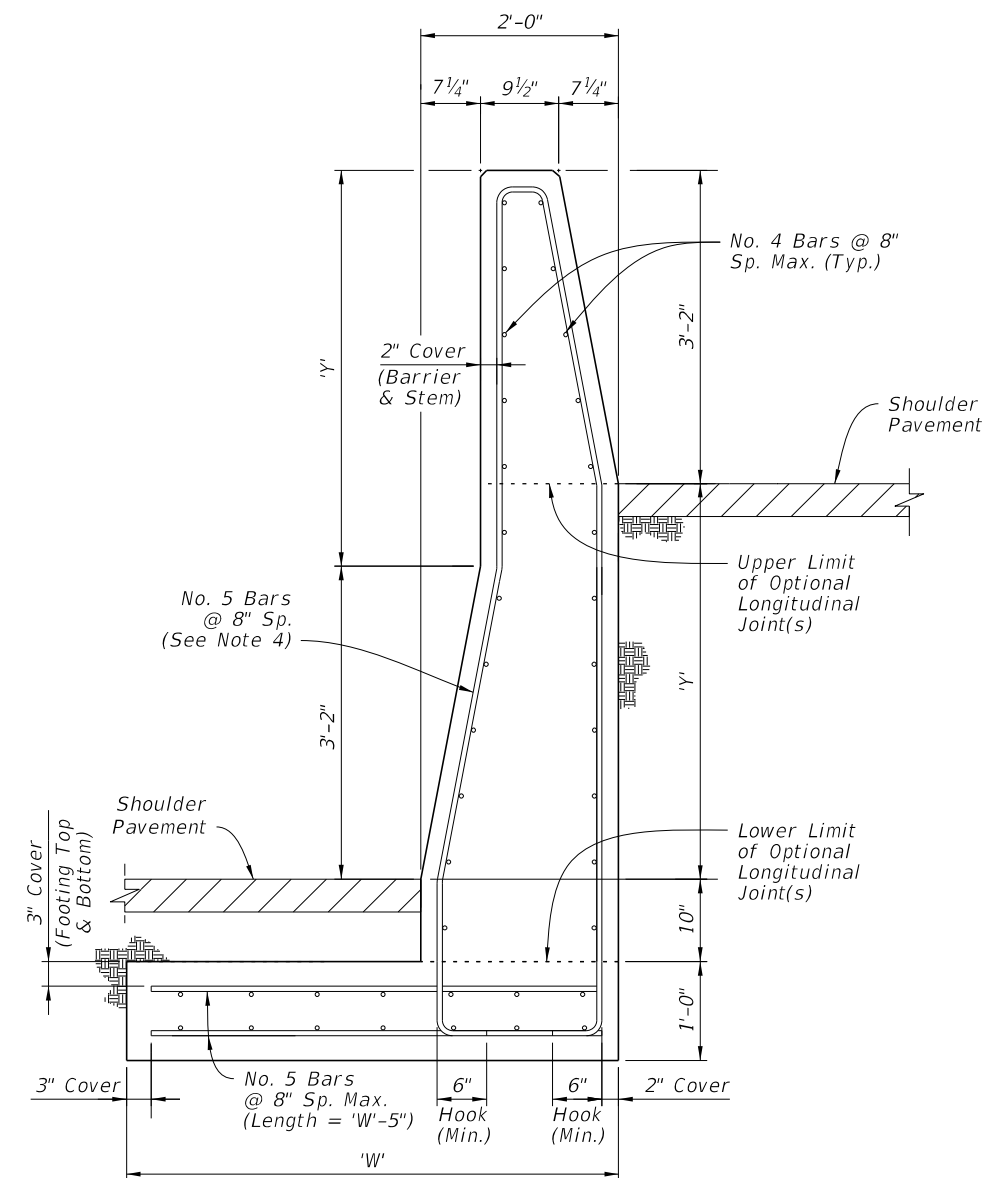

TALL GRADE-SEPARATED TOE FOOTING SECTION FOR $Y \leq 4'-0"$

NOTES:

- GENERAL:** Install the Grade-Separated sections where shown in the Plans and as required to accommodate vertical offsets in pavement of Height Y. Doweled Joints are not permitted within Grade-Separated sections.
- CONNECTIONS BETWEEN DIFFERENT SECTIONS:** Connect Short Grade-Separated sections and Tall Grade-Separated sections using a continuous pour or Transverse Joint, where longitudinal steel that aligns within the adjacent section is maintained continuously between sections or has a full lap splice with the adjacent section's longitudinal steel. Connect Short Grade-Separated sections and 38" Height Median Barrier sections of Sheet 2 using a 3/4" Doweled Joint.
- SHORT GRADE-SEPARATED SECTIONS:** Bars 4C1 and the two uppermost longitudinal bars may be omitted for segments where $Y < 2"$.
- TALL GRADE-SEPARATED SECTIONS:** For the vertical and transverse steel reinforcement shown in the Tall Grade-Separated Sections, bar bending diagrams are not provided due to varying section dimensions and Longitudinal Joint locations. Use any combination of spliced reinforcing steel to position the reinforcement with the same cover, spacing, continuity, and equivalent strength shown herein, as approved by the Engineer.

Longitudinal Joints are permitted between the vertical limits shown, and must remain level and at a consistent height per each continuous casting of concrete. Longitudinal Joints may change elevations at Transverse Joint locations. Field bending of bars is permitted at Longitudinal Joint locations.

Transverse Joints between Tall Grade-Separated Sections do not require continuous steel across the joint if the following conditions are met:

- The barrier length on both sides is at least 40 feet, where each segment has continuous steel reinforcement.
- The barrier's vertical steel spacing is reduced to 4" O.C. for a total of 12 spaces on both sides of the joint.

Grade separation Heights of $Y \leq 9"$ are permitted on a limited basis using the Tall Grade-Separated section; this is to accommodate cases where maintaining the spread footing through lower height segments is more practical than changing to the Short Grade-Separated section.

TALL GRADE-SEPARATED SECTIONS DIMENSION TABLE							
Max. Height, Y	1'-0"	1'-6"	2'-0"	2'-6"	3'-0"	3'-6"	4'-0"
Footing Width, W	3'-3"	3'-6"	3'-9"	4'-0"	4'-3"	4'-6"	4'-6"

10/20/2022 8:50:49 AM

MEDIAN BARRIER - GRADE-SEPARATED

LAST REVISION 11/01/18	DESCRIPTION:		FY 2023-24 STANDARD PLANS	CONCRETE BARRIER	INDEX	SHEET
			521-001		5 of 26	

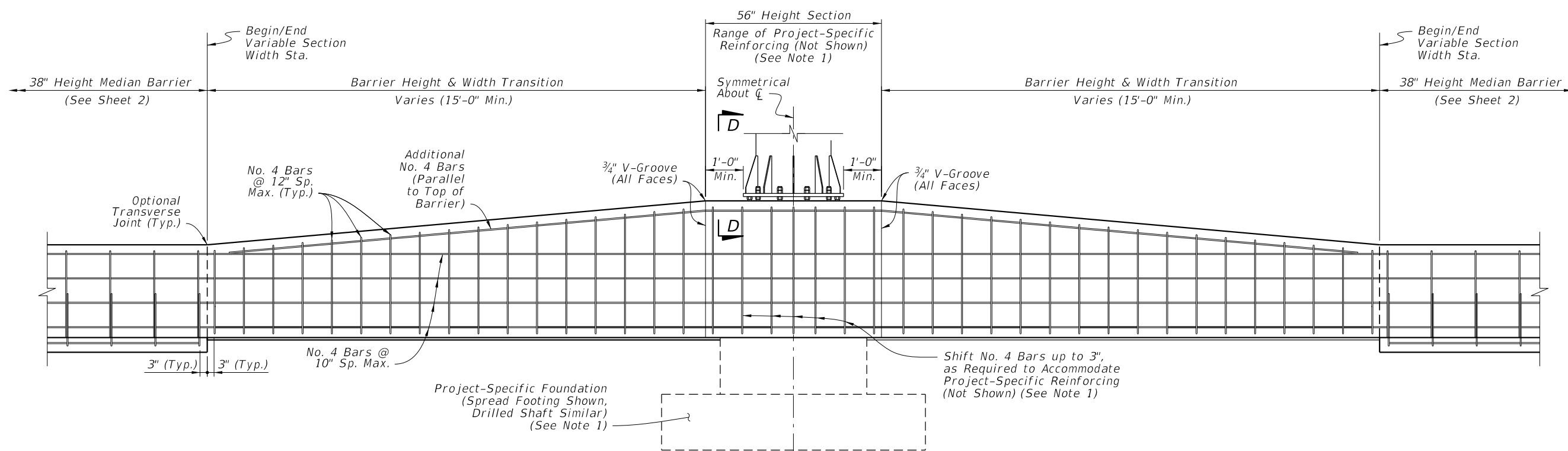

ELEVATION

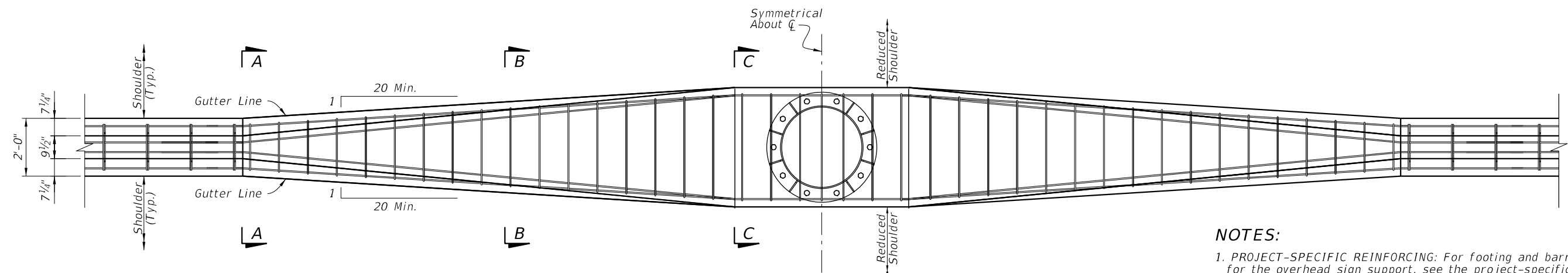

PLAN
(See Note 4)

NOTES:

1. PROJECT-SPECIFIC REINFORCING: For footing and barrier reinforcing required for the overhead sign support, see the project-specific design in the Plans.
2. BARRIER REINFORCING: Maintain the 38" Height Median Barrier's longitudinal steel reinforcing continuously through the barrier height transition and pedestal. Provide the Additional No. 4 Bars and taper as required to maintain a 4 1/2" maximum cover from the top of the barrier.

For the vertical and transverse reinforcement requirements shown in Sections A-A through C-C, bar bending diagrams are not provided due to varying section dimensions. Use any combination of spliced reinforcing steel to position the reinforcement with the same cover, spacing, continuity, and equivalent strength shown herein, as approved by the Engineer.
3. PROJECT-SPECIFIC PEDESTAL WIDTH & SETBACK: The pedestal width is governed by the size requirements of the overhead sign support, as detailed in the Plans. Likewise, the setback distance from the sign support base to the barrier face is governed by the anchor bolt cover requirements, as defined per the Plans. The minimum pedestal width is 2'-0", where a complete removal of the gutter line taper is permitted.
4. PLAN VIEW: Only top and bottom longitudinal reinforcing is shown for clarity. For all longitudinal reinforcing locations, see the Section Views.

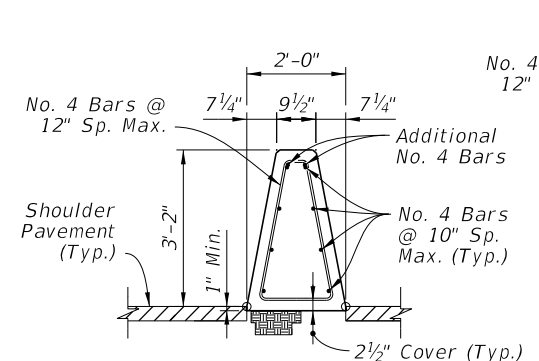

SECTION A-A
BEGIN TRANSITION

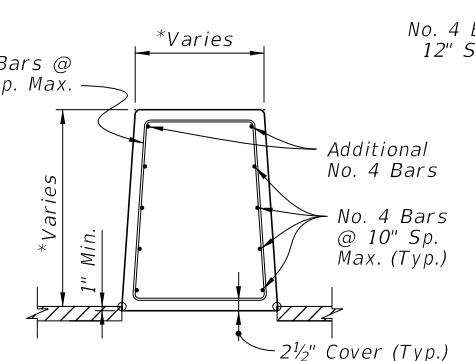

SECTION B-B
*Dimension Varies Linearly
Between Section A-A and C-C

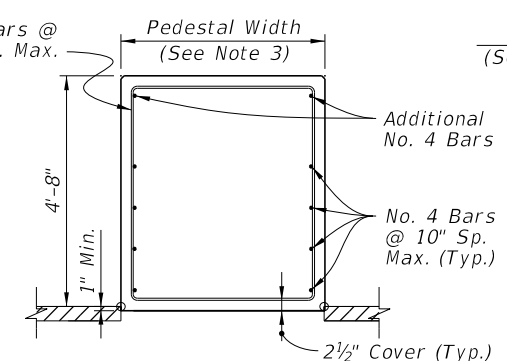

SECTION C-C
END TRANSITION
(56" Height Section)

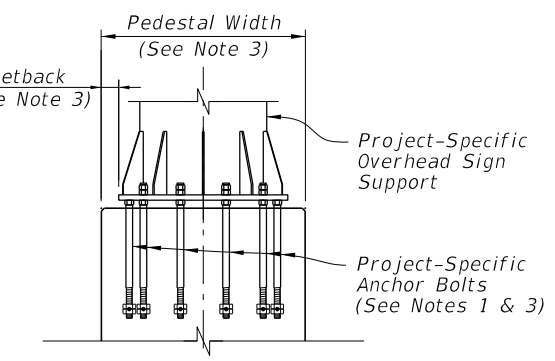

SECTION D-D
(Reinforcing Steel Not
Shown for Clarity)

MEDIAN BARRIER - 56" HEIGHT SECTION FOR BARRIER-MOUNTED SIGN SUPPORT SHIELDING - SYMMETRICAL

10/20/2022 8:50:49 AM

LAST REVISION 11/01/18	DESCRIPTION:		FY 2023-24 STANDARD PLANS	CONCRETE BARRIER	INDEX	SHEET
			521-001		6 of 26	

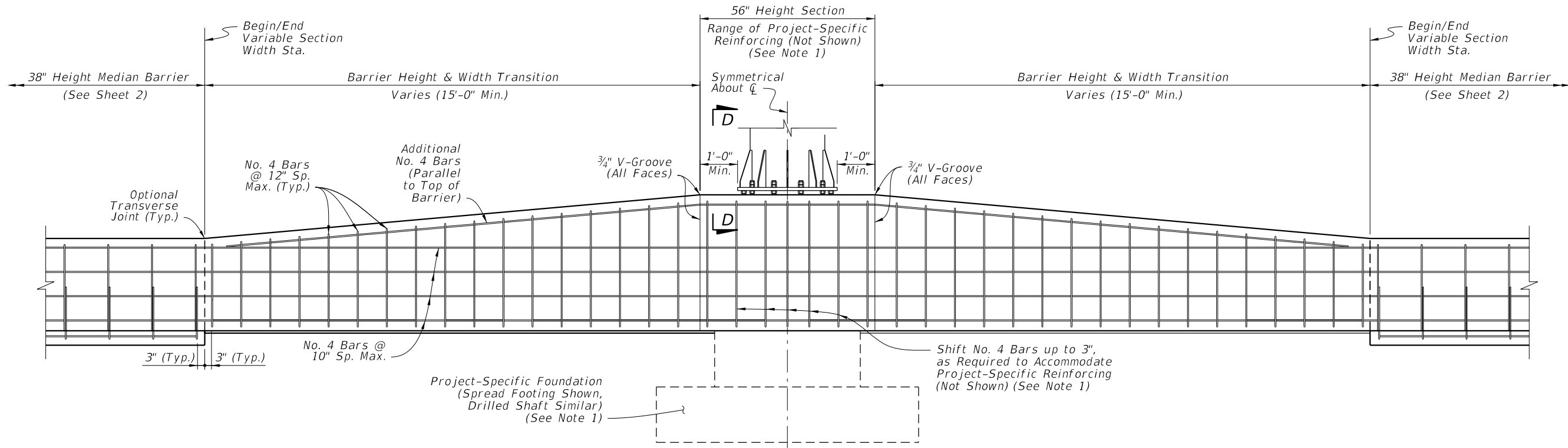

ELEVATION

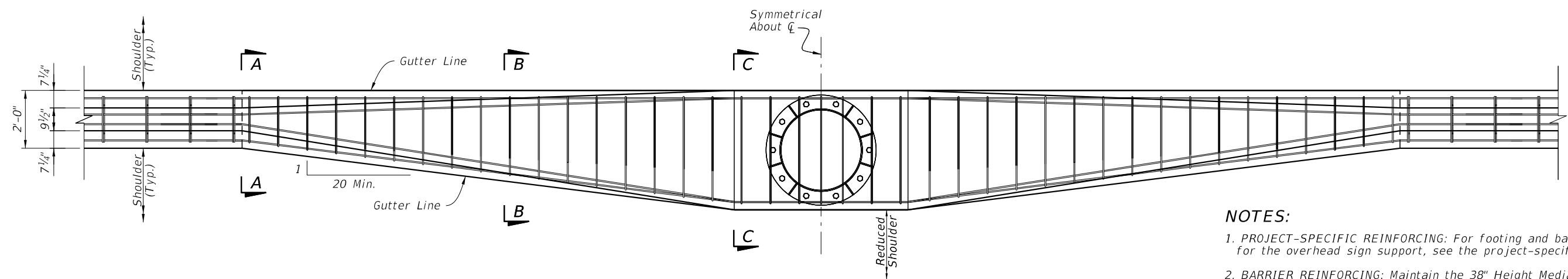

PLAN
(See Note 4)

NOTES:

1. PROJECT-SPECIFIC REINFORCING: For footing and barrier reinforcing required for the overhead sign support, see the project-specific design in the Plans.
2. BARRIER REINFORCING: Maintain the 38" Height Median Barrier's longitudinal steel reinforcing continuously through the barrier height transition and pedestal. Provide the Additional No. 4 Bars and taper as required to maintain a 4 1/2" maximum cover from the top of the barrier.

For the vertical and transverse reinforcement requirements shown in Sections A-A through C-C, bar bending diagrams are not provided due to varying section dimensions. Use any combination of spliced reinforcing steel to position the reinforcement with the same cover, spacing, continuity, and equivalent strength shown herein, as approved by the Engineer.
3. PROJECT-SPECIFIC PEDESTAL WIDTH & SETBACK: The pedestal width is governed by the size requirements of the overhead sign support, as detailed in the Plans. Likewise, the setback distance from the sign support base to the barrier face is governed by the anchor bolt cover requirements, as defined per the Plans. The minimum pedestal width is 2'-0", where a complete removal of the gutter line taper is permitted.
4. PLAN VIEW: Only top and bottom longitudinal reinforcing is shown for clarity. For all longitudinal reinforcing locations, see the Section Views.

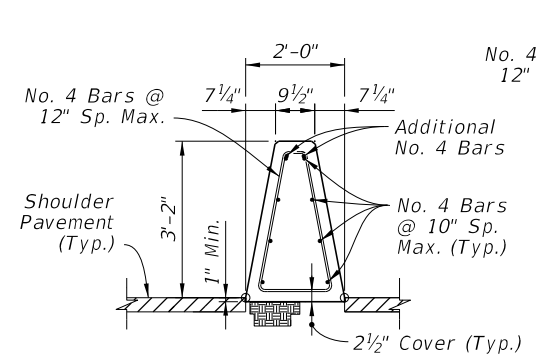

SECTION A-A
BEGIN TRANSITION

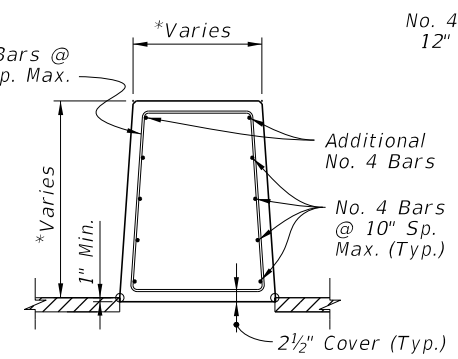

SECTION B-B
*Dimension Varies Linearly
Between Section A-A and C-C

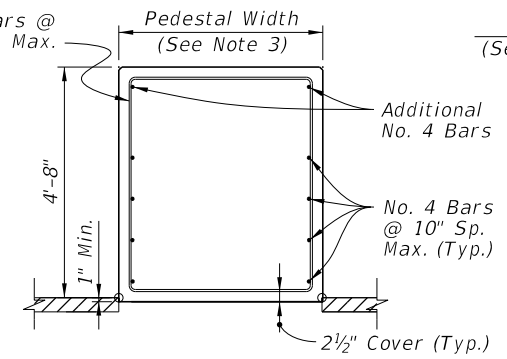

SECTION C-C
END TRANSITION
(56" Height Section)

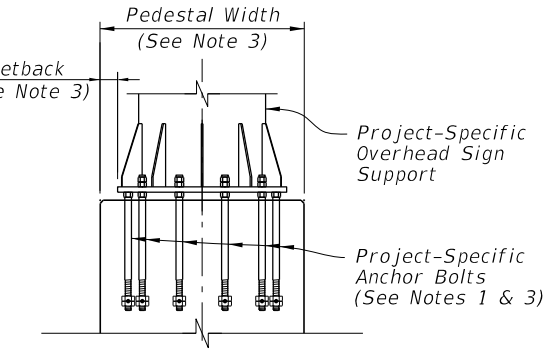

SECTION D-D
(Reinforcing Steel Not
Shown for Clarity)

MEDIAN BARRIER - 56" HEIGHT SECTION
FOR BARRIER-MOUNTED SIGN
SUPPORT SHIELDING - ASYMMETRICAL

10/20/2022 8:50:50 AM

LAST REVISION 11/01/18	DESCRIPTION:		FY 2023-24 STANDARD PLANS	CONCRETE BARRIER	INDEX	SHEET
						521-001

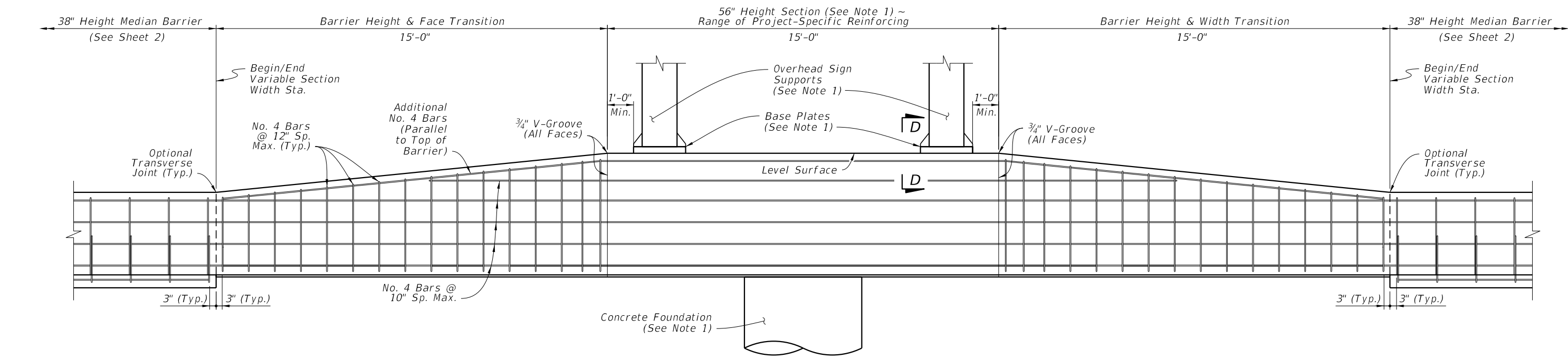

ELEVATION

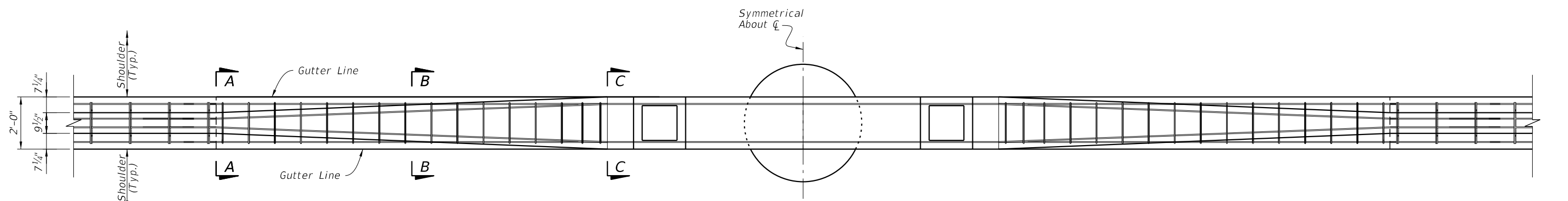

PLAN
(See Note 3)

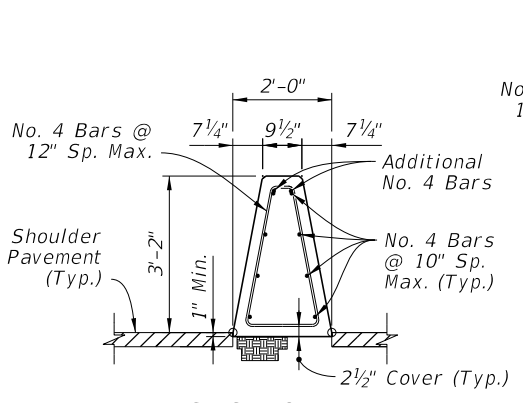

SECTION A-A
BEGIN TRANSITION

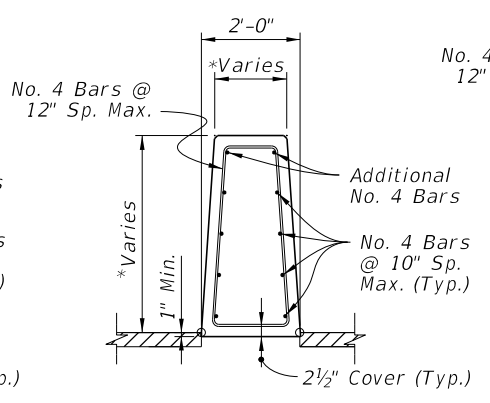

SECTION B-B
*Dimension Varies Linearly
Between Section A-A and C-C

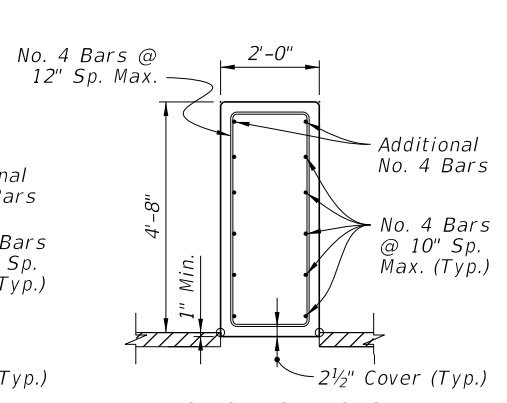

SECTION C-C
END TRANSITION
(56" Height Section)

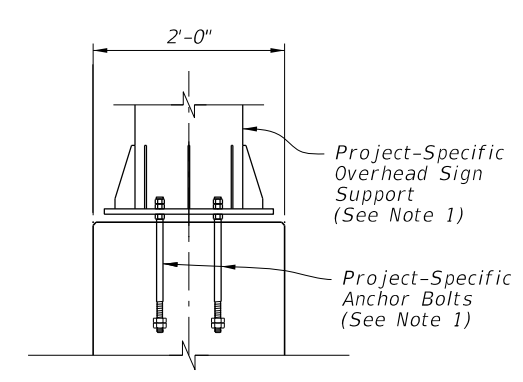

SECTION D-D
(Reinforcing Steel Not
Shown for Clarity)

NOTES:

1. PROJECT-SPECIFIC DESIGN: For the base plate, anchor bolts, foundation design, and additional reinforcing required for the barrier, see the project-specific design in the Plans.
2. BARRIER REINFORCING: Maintain the 38" Height Median Barrier's longitudinal steel reinforcing continuously through the barrier height transition and pedestal. Provide the Additional No. 4 Bars and taper as required to maintain a 4 1/2" maximum cover from the top of the barrier.

For the vertical and transverse reinforcement requirements shown in Sections A-A through C-C, bar bending diagrams are not provided due to varying section dimensions. Use any combination of spliced reinforcing steel to position the reinforcement with the same cover, spacing, continuity, and equivalent strength shown herein, as approved by the Engineer.
3. PLAN VIEW: Only top and bottom longitudinal reinforcing is shown for clarity. For all longitudinal reinforcing locations, see the Section Views.

MEDIAN BARRIER - 56" HEIGHT SECTION FOR BARRIER-MOUNTED DUAL SIGN SUPPORT SHIELDING - MINIMUM WIDTH

10/20/2022 8:50:51 AM

LAST REVISION 11/01/18	REVISION	DESCRIPTION:		FY 2023-24 STANDARD PLANS	CONCRETE BARRIER	INDEX 521-001	SHEET 8 of 26
---------------------------	----------	--------------	--	------------------------------	------------------	------------------	------------------

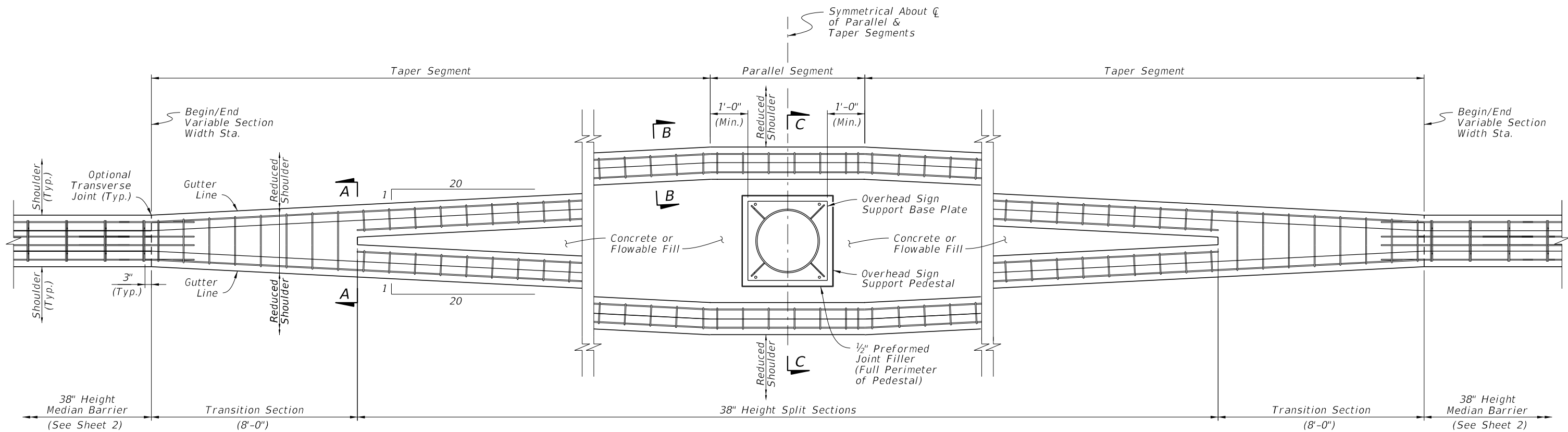

PLAN
(See Note 3)

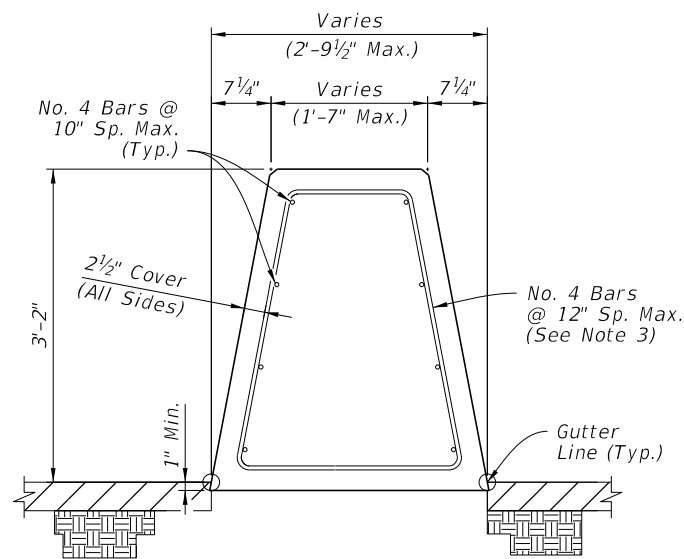

SECTION A-A
TRANSITION SECTION
(AT BEGIN
SPLIT SECTIONS)

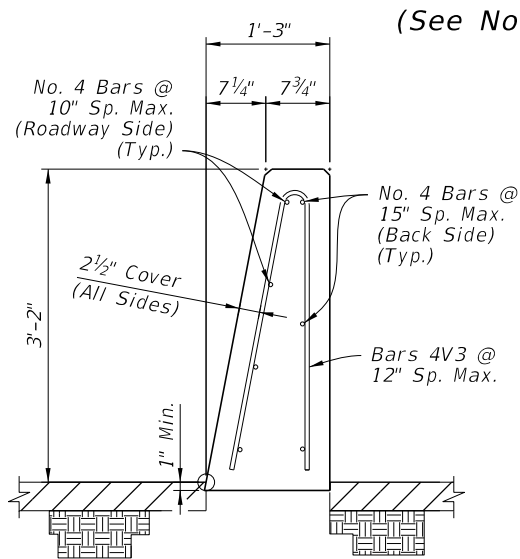

SECTION B-B
38" HEIGHT SPLIT SECTION
(OPPOSITE SIDE SIMILAR
BY OPPOSITE HAND)

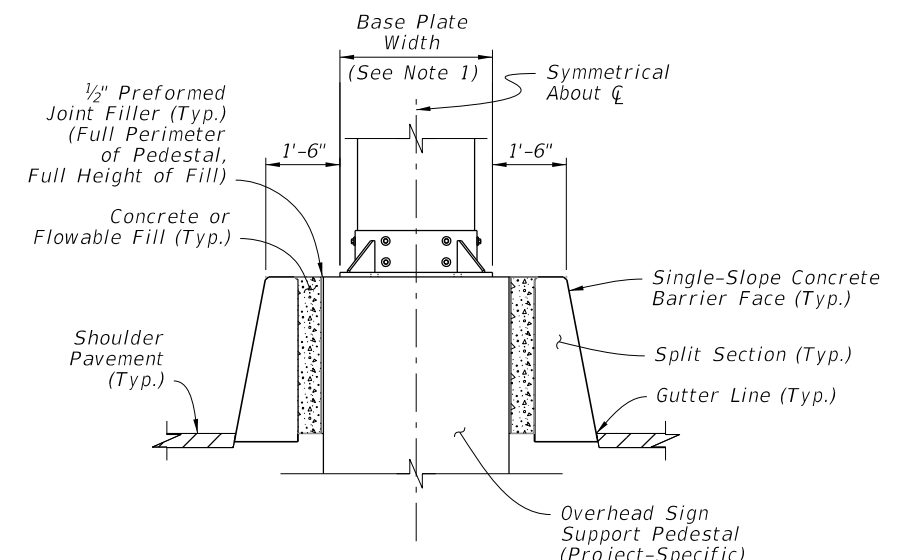

SECTION C-C

NOTES:

- OVERHEAD SIGN SUPPORT:** The overhead sign support shown is an example only; see the Plans for the project-specific dimensions and requirements. The overall length and width of the barrier's taper and parallel segments is governed by the overhead sign support dimensions as defined in the Plans.
- MULTIPLE SIGN SUPPORTS:** The parallel segment may be lengthened to accommodate multiple sign supports, with the approach and trailing tapers located 1 foot, measured longitudinally, upstream and downstream from the first and last sign support bases, respectively.
- PLAN VIEW:** Only outermost longitudinal reinforcing is shown for clarity. For all longitudinal reinforcing locations, see the Section Views.
- STIRRUP BARS:** For the vertical and transverse reinforcement requirements shown in Sections A-A, bar bending diagrams are not provided due to varying section dimensions. Use any combination of spliced reinforcing steel to position the reinforcement with the same cover, spacing, continuity, and equivalent strength shown herein, as approved by the Engineer.
- CONCRETE OR FLOWABLE FILL:** Use Class NS Concrete in accordance with Specification 347 or Non-Excavatable Flowable Fill in accordance with Specification 121.

MEDIAN BARRIER - 38" HEIGHT SPLIT SECTION
FOR STAND-ALONE SIGN SUPPORT SHIELDING

10/20/2022 8:50:52 AM

LAST REVISION 11/01/18	DESCRIPTION:		FY 2023-24 STANDARD PLANS	CONCRETE BARRIER	INDEX	SHEET
					521-001	9 of 26

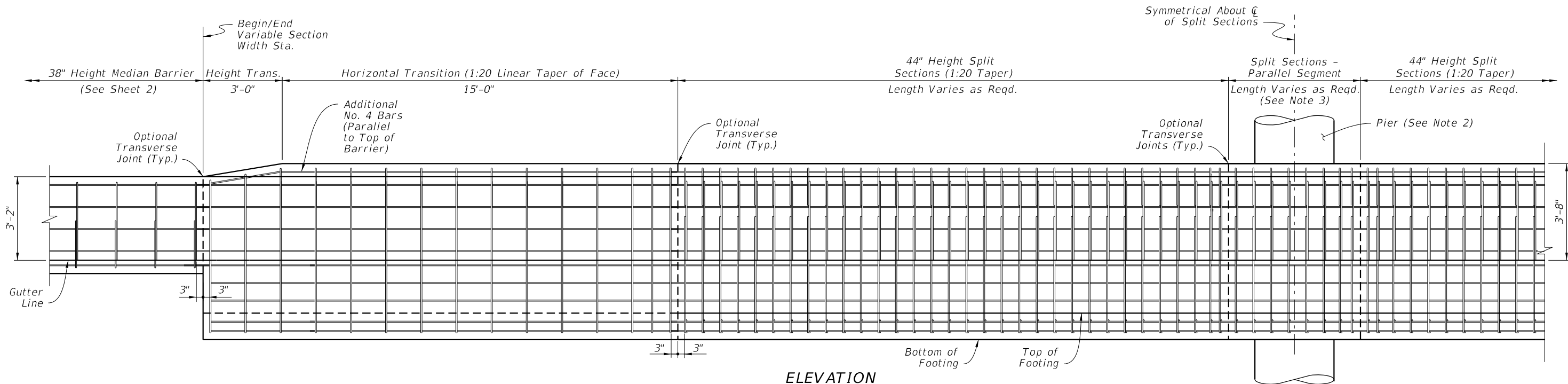

ELEVATION

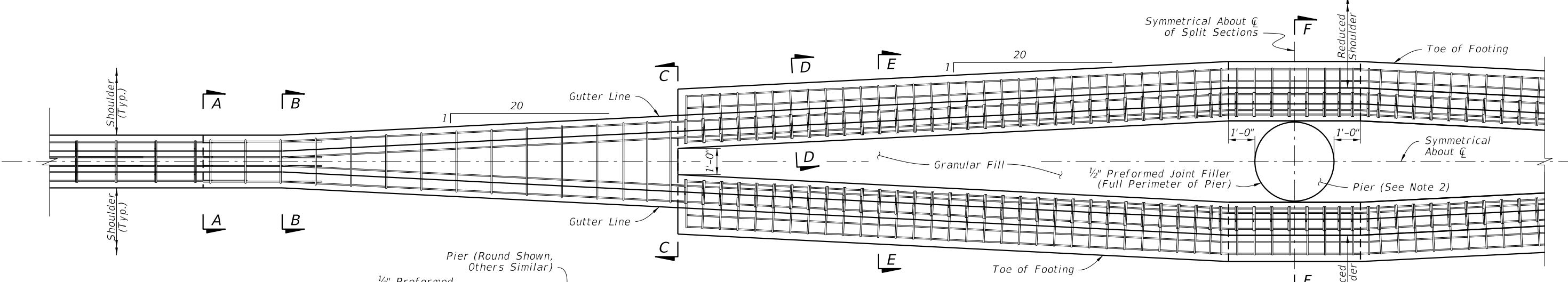

PLAN
(See Section Views on Sheet 11 for All Longitudinal Steel Locations)

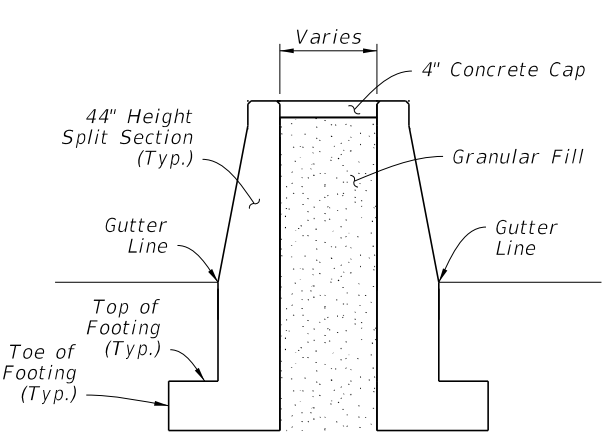

SECTION E-E
SPLIT SECTIONS

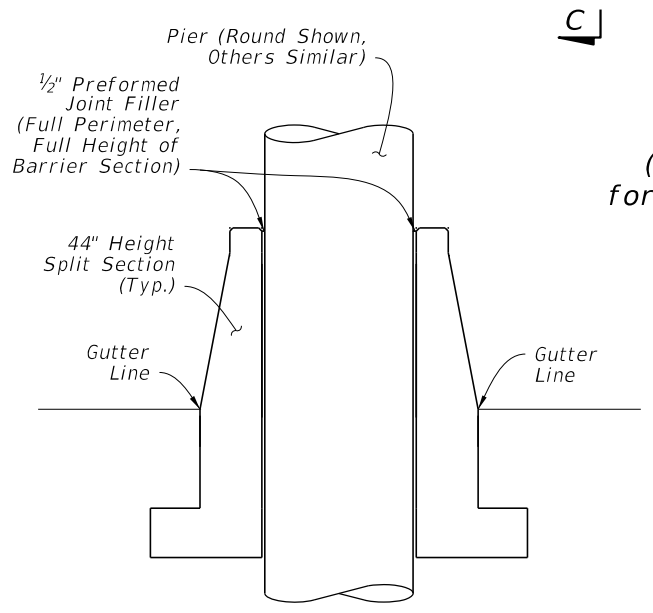

SECTION F-F
SPLIT SECTIONS AT PIER

NOTES:

1. SECTION VIEWS: See Sheet 11 for Section Views A-A through D-D and corresponding reinforcing steel details.
2. PIER: The round pier shown is an example only, and project-specific pier shapes may vary. For actual dimensions and requirements, see the Plans. The overall length and width of the split barrier system is governed by the project-specific pier dimensions, as defined in the Plans.
3. MULTIPLE PIERS: The parallel segment may be lengthened to accommodate multiple consecutive piers, with the approach and trailing tapers located 1 foot, measured longitudinally, upstream and downstream from the first and last piers, respectively.

MEDIAN BARRIER - 44" HEIGHT
SPLIT SECTION FOR PIER SHIELDING

10/20/2022 8:50:53 AM

LAST REVISION 11/01/18	DESCRIPTION:		FY 2023-24 STANDARD PLANS	CONCRETE BARRIER	INDEX 521-001	SHEET 10 of 26
REVISION						

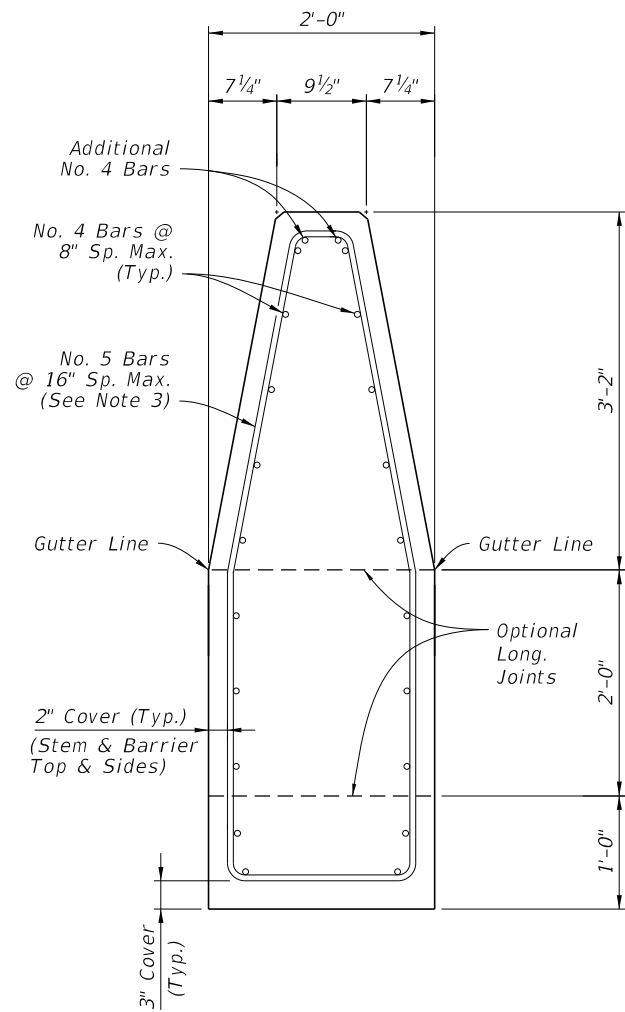

SECTION A-A
BEGIN HEIGHT
TRANSITION
 (show spliced bars)

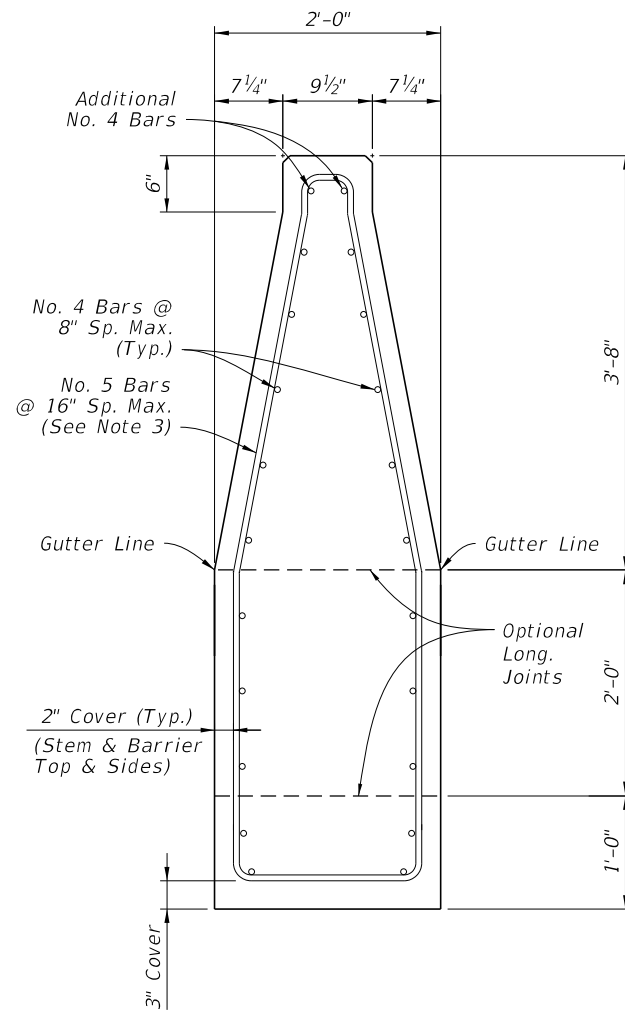

SECTION B-B
END HEIGHT TRANSITION
BEGIN WIDTH TRANSITION

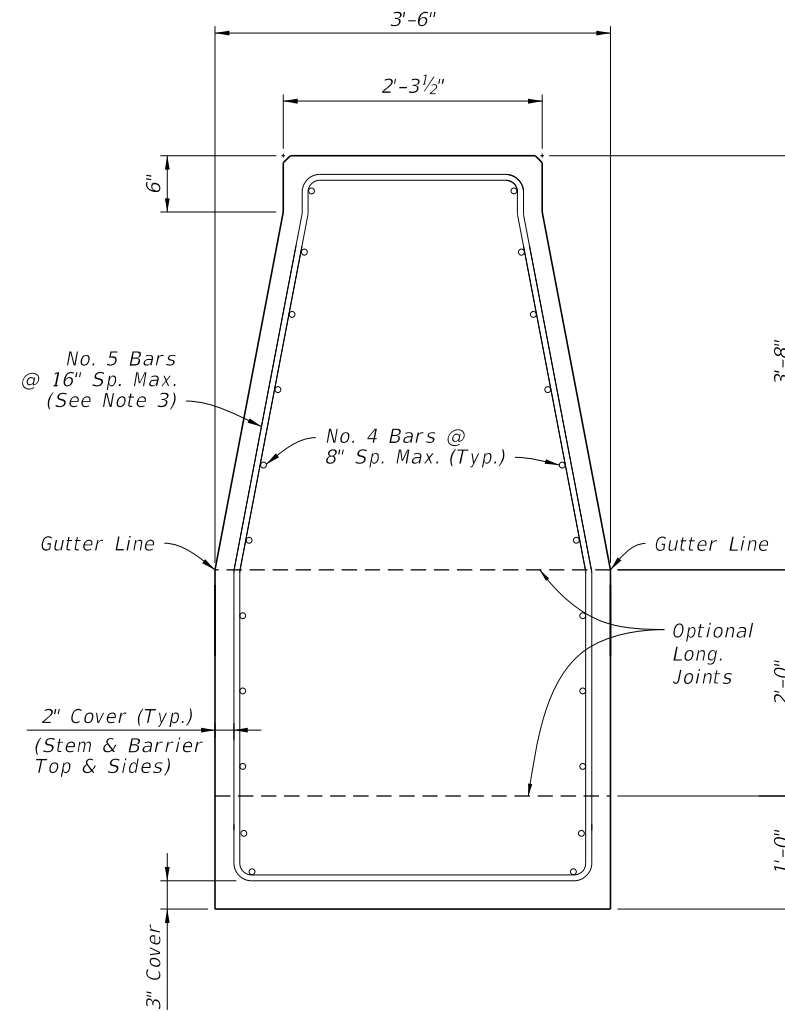

SECTION C-C
END WIDTH TRANSITION
BEGIN SPLIT SECTIONS

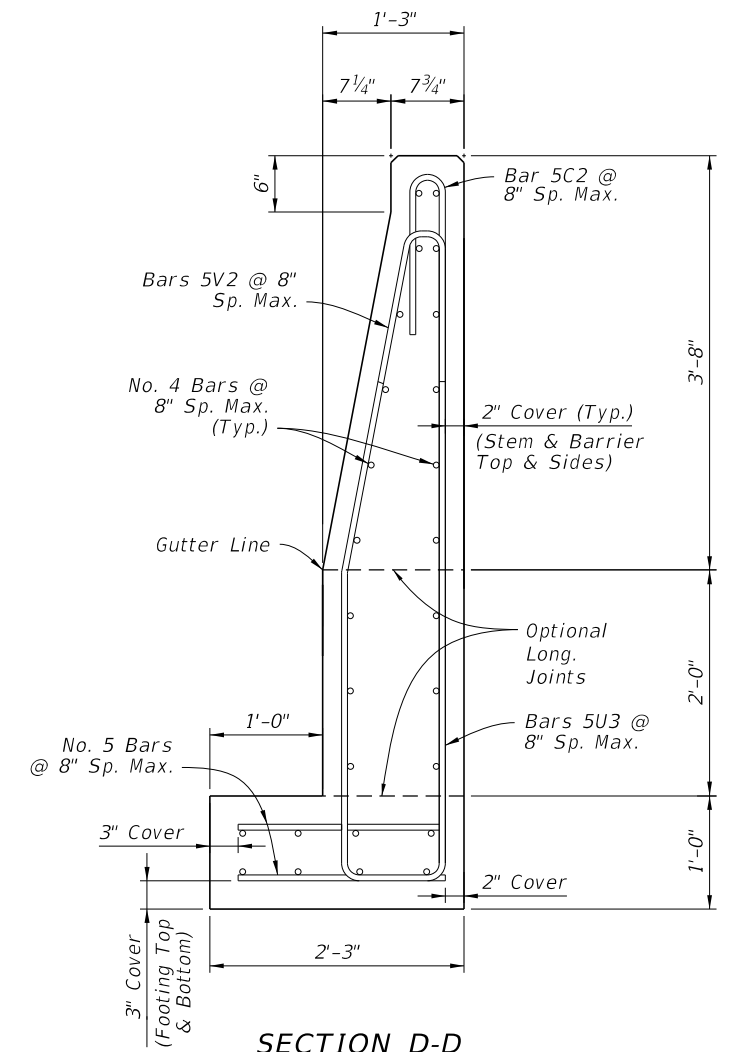

SECTION D-D
44" HEIGHT SPLIT SECTION
(Opposite Side of Median
Similar by Opposite Hand)

Concrete Qty. = 0.30 CY/FT
 Steel Qty. = 52.6 LB/FT

NOTES:

1. GENERAL: Work with the Plan and Elevation views on Sheet 10.
2. LONGITUDINAL REINFORCING CONTINUITY: Maintain all longitudinal steel reinforcing shown in Section C-C continuously into Section D-D (spliced where required). The additional longitudinal reinforcing shown in Section D-D does not require continuity into Section C-C, and it starts 3" from the construction joint or edge of concrete per the details on Sheet 10.
3. STIRRUP BARS: For the vertical and transverse reinforcement requirement shown, bar bending diagrams are not provided due to varying section dimensions. Use any combination of spliced reinforcing steel to position the reinforcement with the same cover, spacing, continuity, and equivalent strength shown herein, as approved by the Engineer.

MEDIAN BARRIER - 44" HEIGHT
SPLIT SECTION FOR PIER SHIELDING - DETAILS

10/20/2022 8:50:54 AM

LAST REVISION 11/01/18	DESCRIPTION:	 FY 2023-24 STANDARD PLANS	CONCRETE BARRIER	INDEX 521-001	SHEET 11 of 26
---------------------------	--------------	--	-------------------------	-------------------------	--------------------------

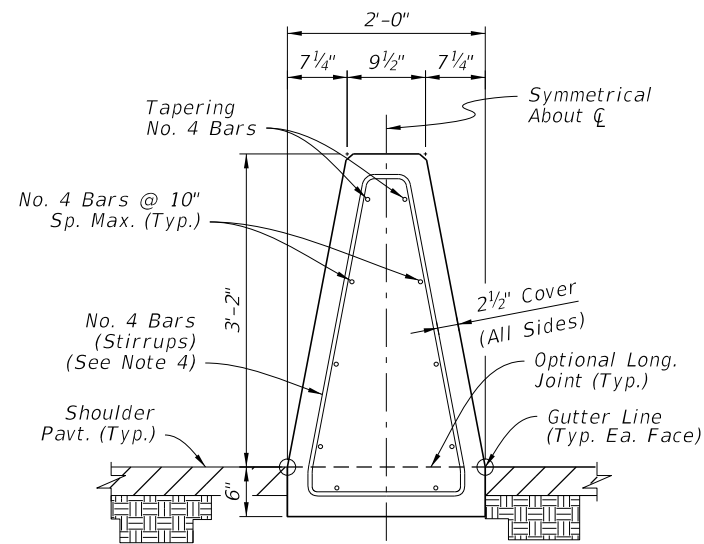

SECTION A-A
BEGIN TRANSITION - OPTION 'A'
MATCH SINGLE-SLOPE
38" HEIGHT MEDIAN BARRIER

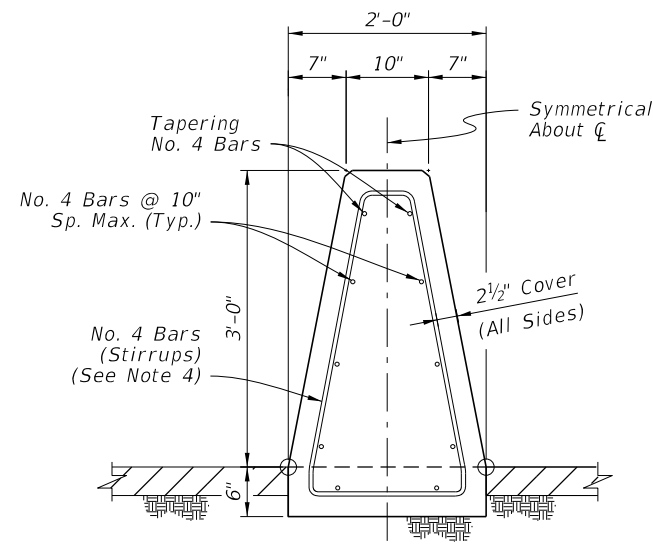

SECTION A-A
BEGIN TRANSITION - OPTION 'B'
MATCH SINGLE-SLOPE
36" HEIGHT TRAFFIC RAILING
(Bridge Applications)

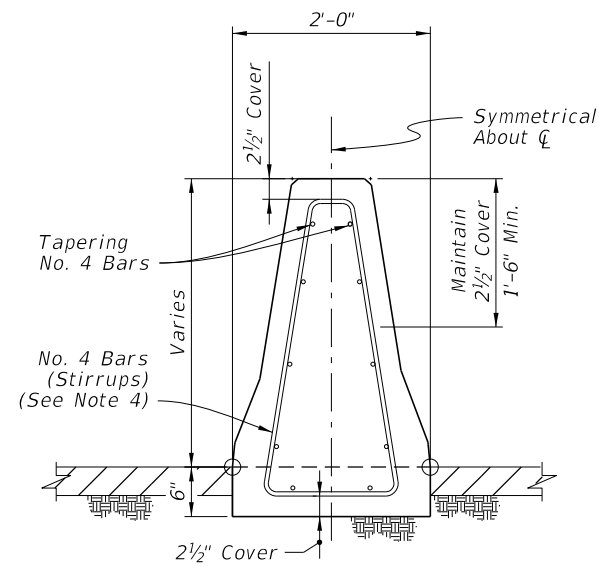

SECTION B-B
INTERMEDIATE SECTION
OF LINEAR TRANSITION

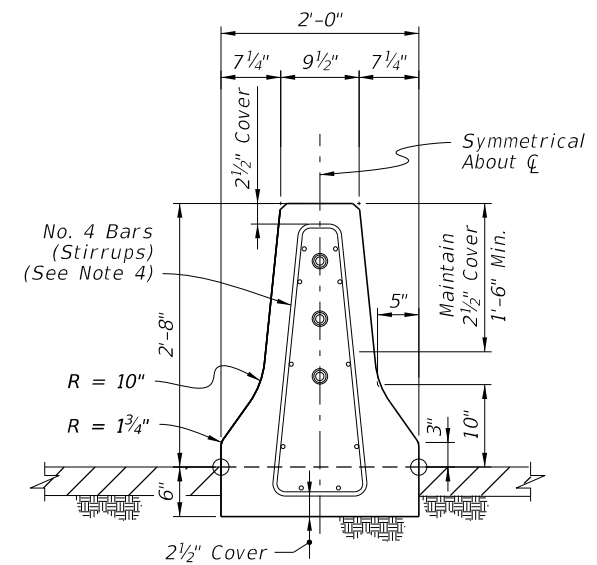

SECTION C-C
END TRANSITION
MATCH 32" HEIGHT
F-SHAPE SECTION

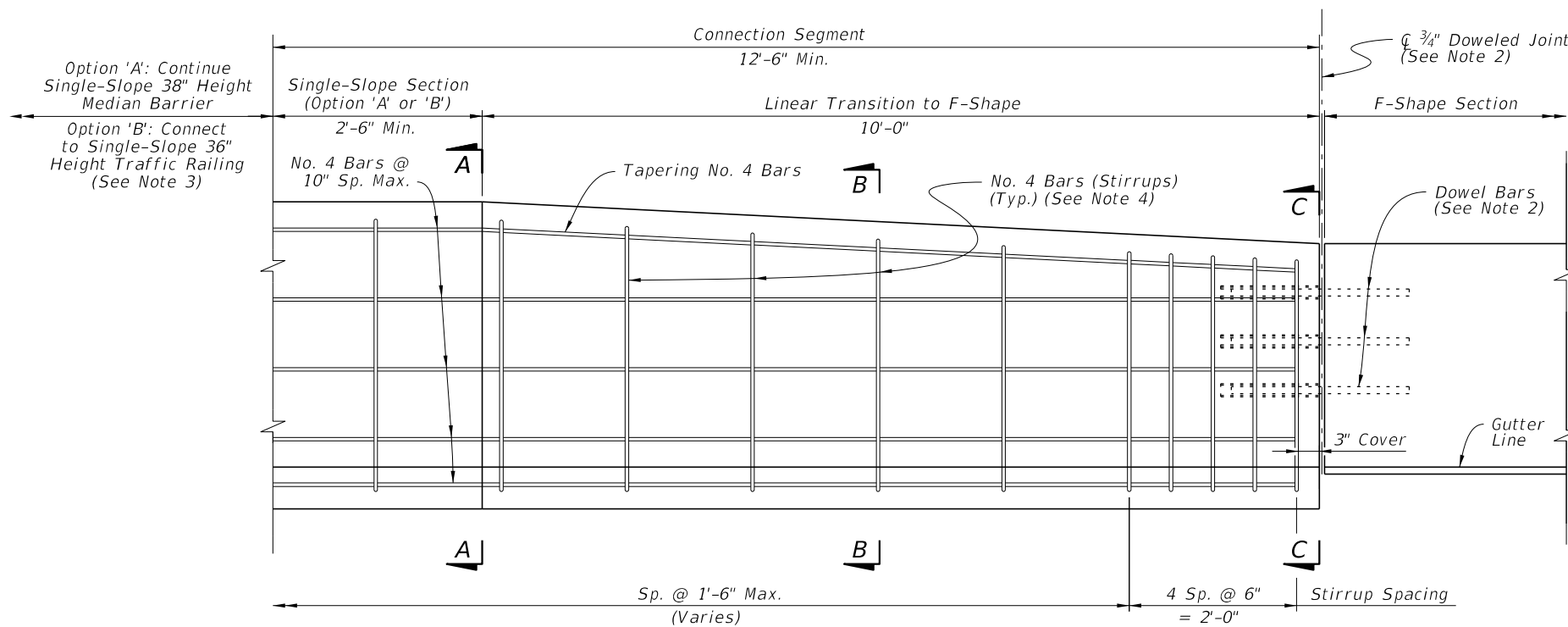

ELEVATION
(Reverse Direction Similar
by Opposite Hand)

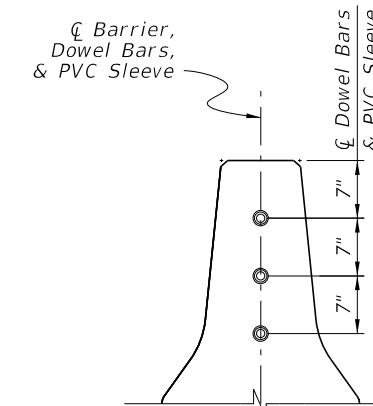

SECTION - F-SHAPE
DOWEL PLACEMENT
(See Note 2)

NOTES:

- GENERAL:** Construct the Connection Segment as required per the Plans to connect existing F-Shape sections to Single-Slope Median Barrier or Traffic Railing sections. Construct Option 'A' or 'B' as required to match the heights of the connecting sections.
- DOWELED JOINT:** Install Dowel Bars per the Dowel Details on Sheet 2.
- TRAFFIC RAILING CONNECTION:** For the Option 'B' connection, use a Doweled Joint per Sheet 2 and the additional Free End Reinforcing with reduced bar spacing per Sheet 3.
- STIRRUP BARS:** For the vertical and transverse reinforcement requirements shown, bar bending diagrams are not provided due to varying section dimensions. Use any combination of spliced reinforcing steel to position the reinforcement with the same cover, spacing, continuity, and equivalent strength shown herein, as approved by the Engineer.

MEDIAN BARRIER - CONNECTION TO F-SHAPE

10/20/2022 8:50:54 AM

LAST REVISION 11/01/18	DESCRIPTION:		FY 2023-24 STANDARD PLANS	CONCRETE BARRIER	INDEX	SHEET
					521-001	12 of 26

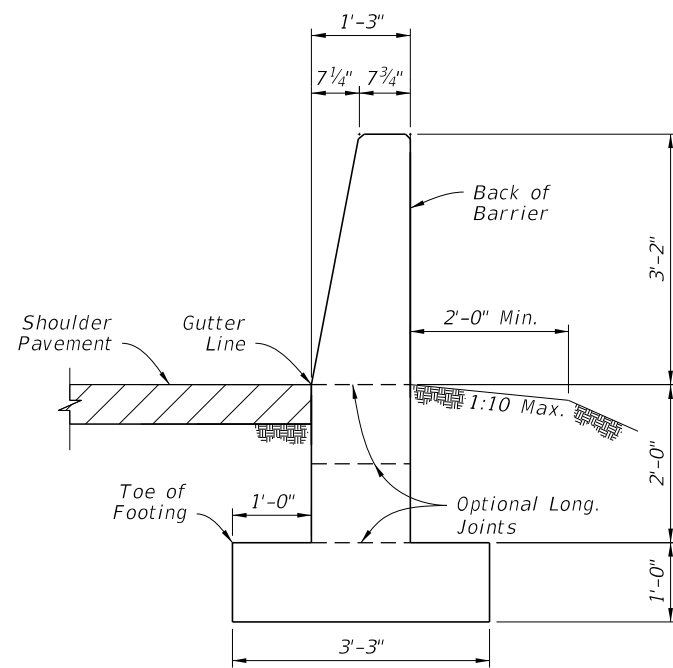

SECTION A-A
38" HEIGHT SHOULDER BARRIER
 (See Sheet 14 for
 Reinforcing Steel Details)

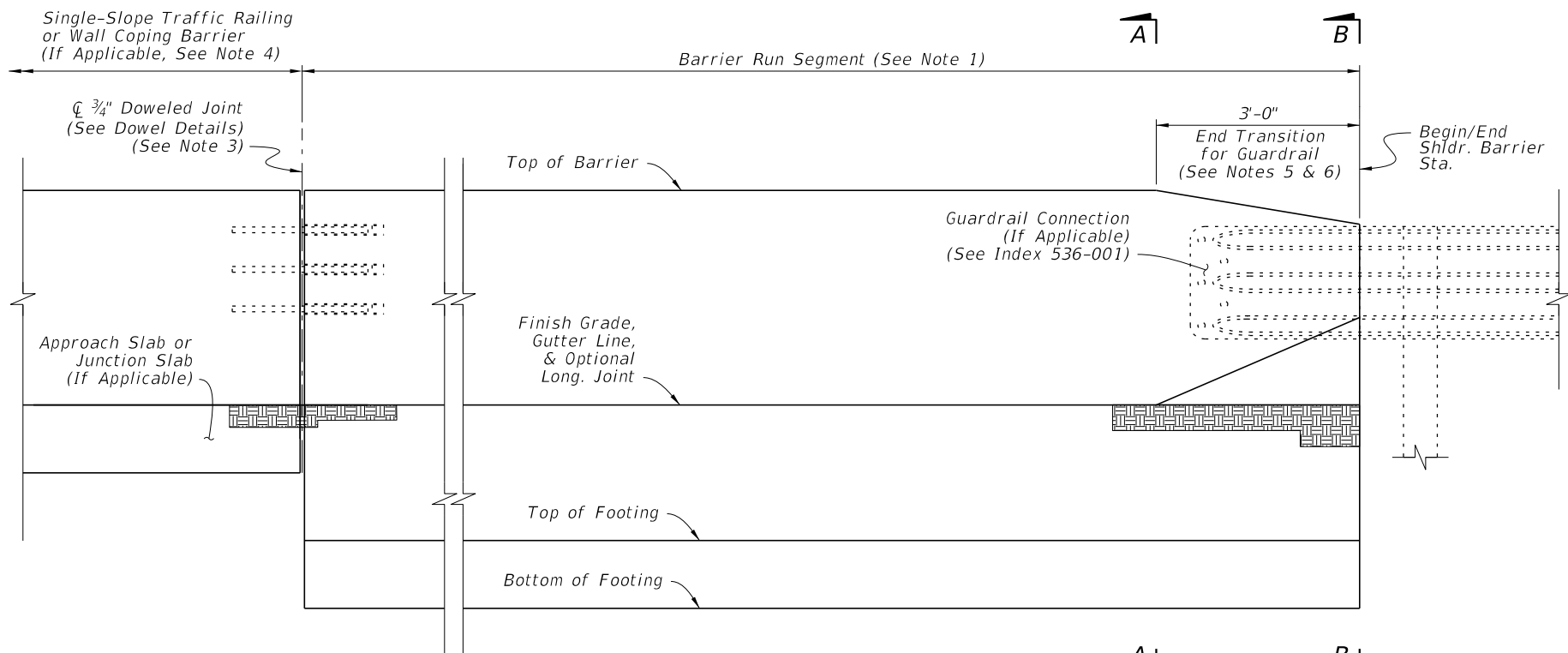

ELEVATION

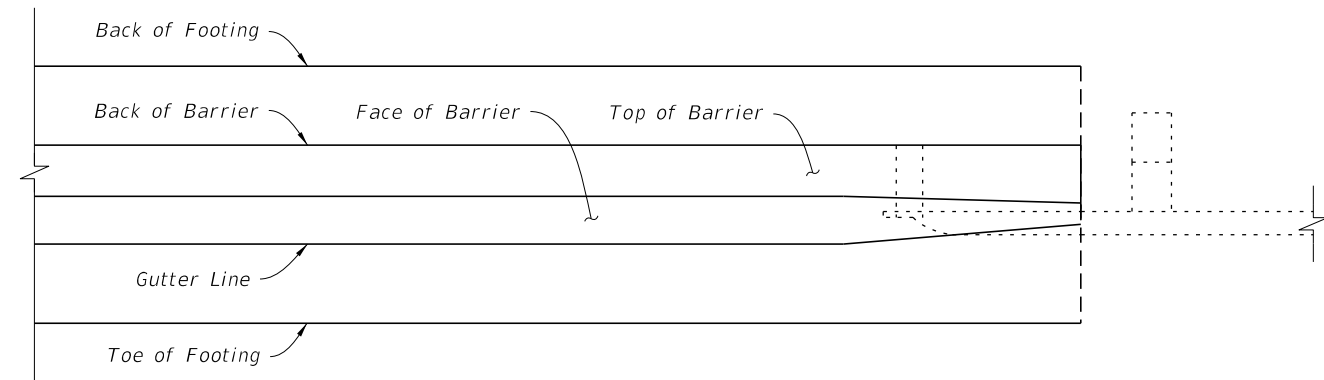

PLAN

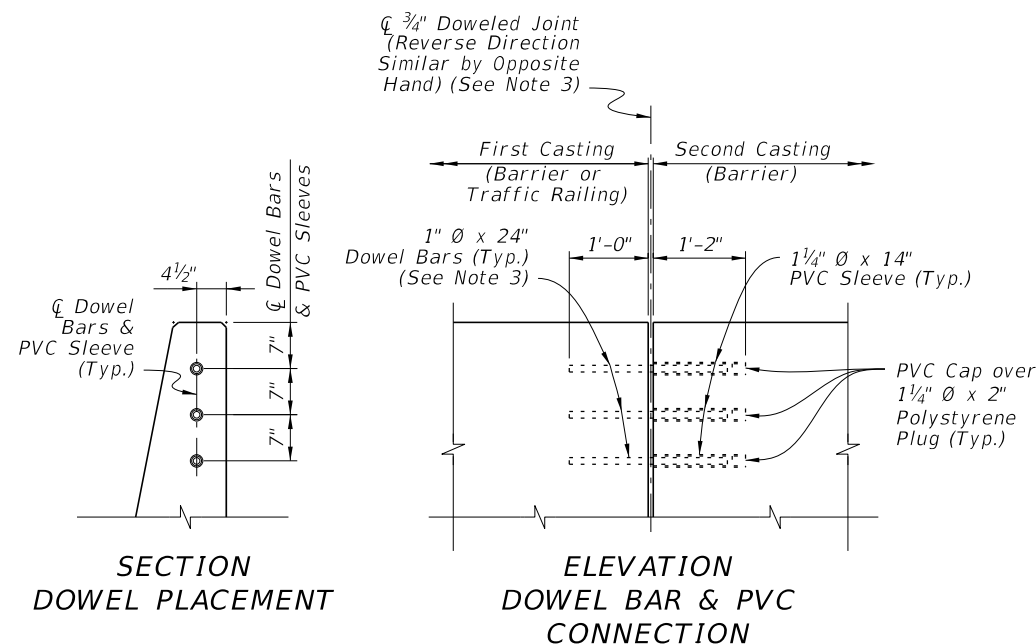

DOWEL DETAILS

SHOULDER BARRIER NOTES:

- BARRIER RUN SEGMENT:** Either the 38" Height Shoulder Barrier or the differing Shoulder Barrier sections shown throughout the Index may be placed within this segment as required per the Plans.
- SECTION VIEWS:** For additional Views A-A and B-B, see Sheet 14.
- DOWELED JOINTS:** See the General Notes on Sheet 1 for usage of joint types. Place steel reinforcing with a longitudinal 3" cover adjacent to the joint face in the barrier. Use ASTM A36 smooth round bars with hot-dip galvanization.

 For the dowel connection into the first casting, the dowel may be cast-in-place for new concrete or placed into a 1 1/8"Ø x 13"(± 1/2") drilled hole for cured concrete. For drilled holes larger than 1 1/8"Ø, secure the dowel with adhesive in accordance with Specification 416. No load testing is required.

 For the dowel connection into the second casting, use a 1 1/4" NPS Schedule 80 PVC pipe with a sealed cap, cast-in-place as shown.
- TRAFFIC RAILING CONNECTIONS:** Align the barrier and Traffic Railing faces and connect with the 3/4" Doweled Joint.
- GUARDRAIL CONNECTIONS:** Connect Guardrail using the Transition Connections to Rigid Barrier per Index 536-001.
- CRASH CUSHION CONNECTIONS:** Connect Crash Cushions per Index 544-001 in conjunction with the 3'-0" End Transition for Guardrail as shown herein.
- FREE ENDS:** When the barrier end does not terminate with a Traffic Railing Connection, Guardrail Connection, or Crash Cushion Connection as called for in the Plans, terminate in accordance with the Free End Reinforcing Note on Sheet 14.

SHOULDER BARRIER

10/20/2022 8:50:55 AM

LAST REVISION 11/01/22	REVISION	DESCRIPTION:		FY 2023-24 STANDARD PLANS	CONCRETE BARRIER	INDEX 521-001	SHEET 13 of 26
---------------------------	----------	--------------	---	--	-------------------------	-------------------------	--------------------------

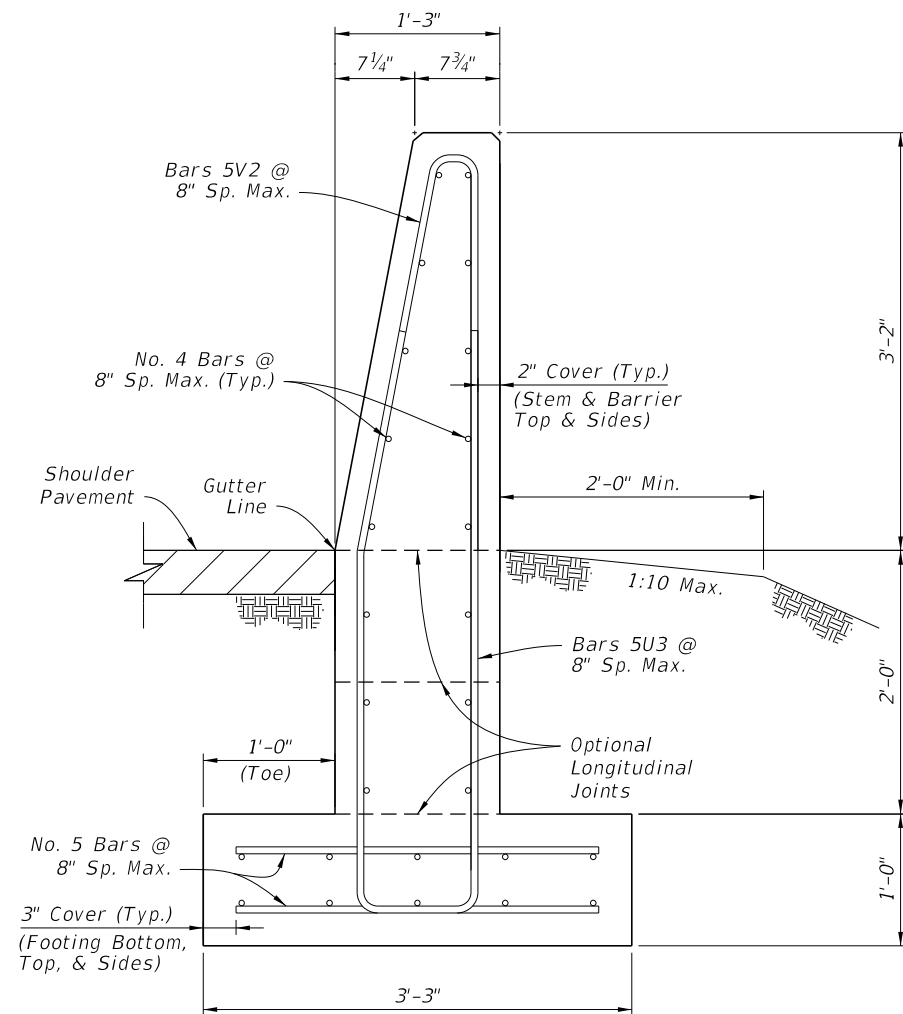

**SECTION A-A
38" HEIGHT SHOULDER BARRIER**

Concrete Qty. = 0.32 CY/FT
Steel Qty. = 50.9 LB/FT

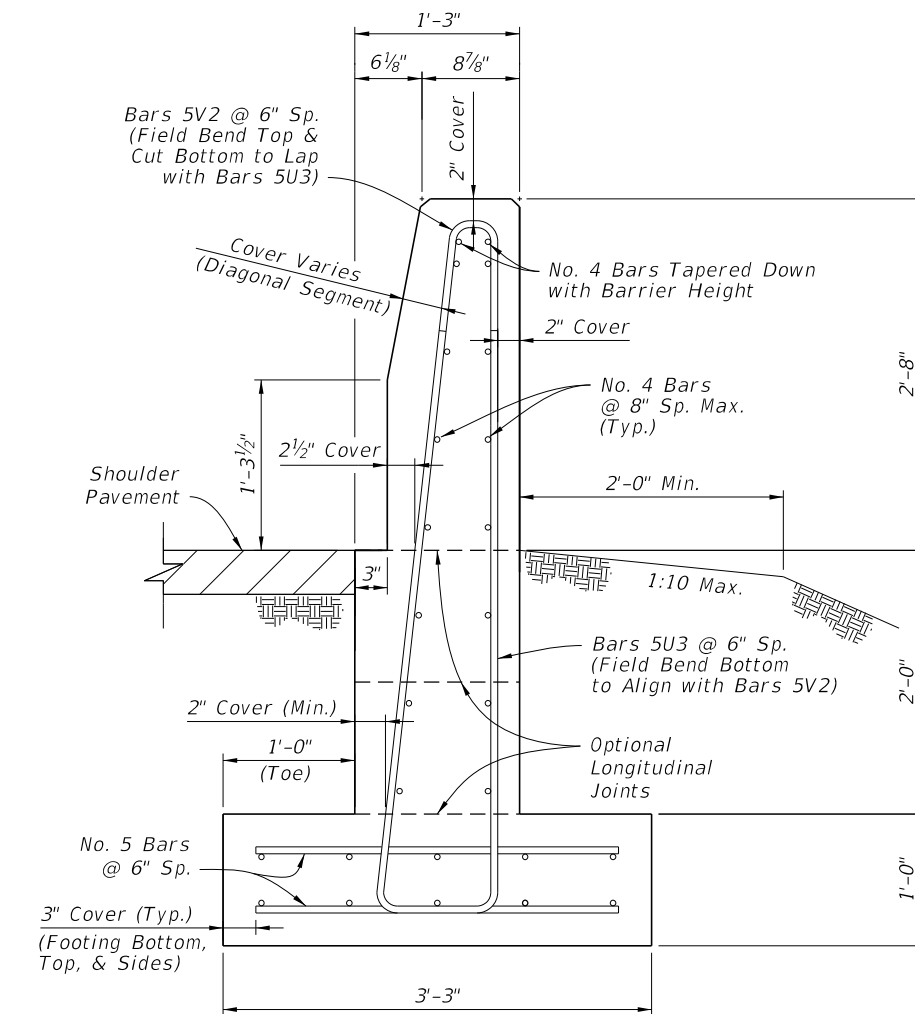

**VIEW B-B
REDUCED SECTION OF
END TRANSITION
FOR GUARDRAIL
(End of Barrier)**

NOTES:

- GENERAL:** Work with the Plan and Elevation Views on Sheet 13. The Section Option footings shown on Sheet 15 may be substituted where called for in the Plans.
- FREE END REINFORCING:** Where shown in the Plans, terminate the 38" Height Barrier section with a transverse vertical end face. Reduce the spacing of Bars 5V2 and 5U3 to 6" for 5 Spaces, placed with 3" cover from the barrier's end face.
- BAR BENDING DIAGRAMS:** For additional details for bars 5V2 and 5U3, see the Bar Bending Diagrams on Sheet 26.

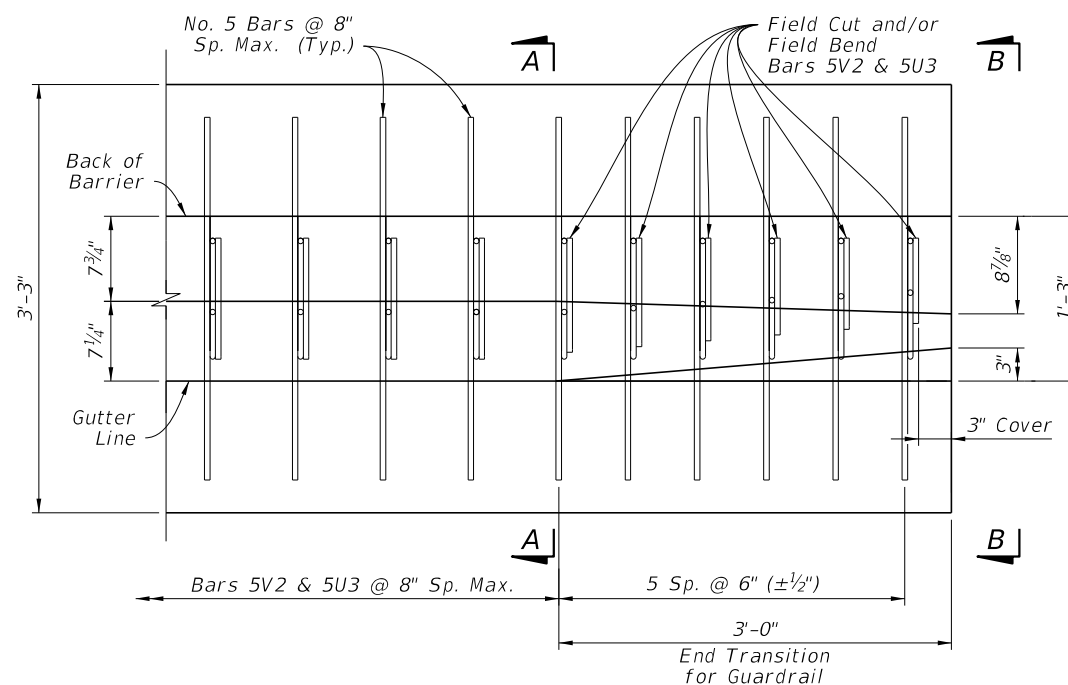

**PLAN VIEW - END SEGMENT FOR GUARDRAIL CONNECTION
(Longitudinal Steel Not Shown for Clarity)**

SHOULDER BARRIER - REINFORCING DETAILS

10/20/2022 8:50:56 AM

LAST REVISION 11/01/18	REVISION	DESCRIPTION:		FY 2023-24 STANDARD PLANS	CONCRETE BARRIER	INDEX 521-001	SHEET 14 of 26
---------------------------	----------	--------------	--	------------------------------	------------------	------------------	-------------------

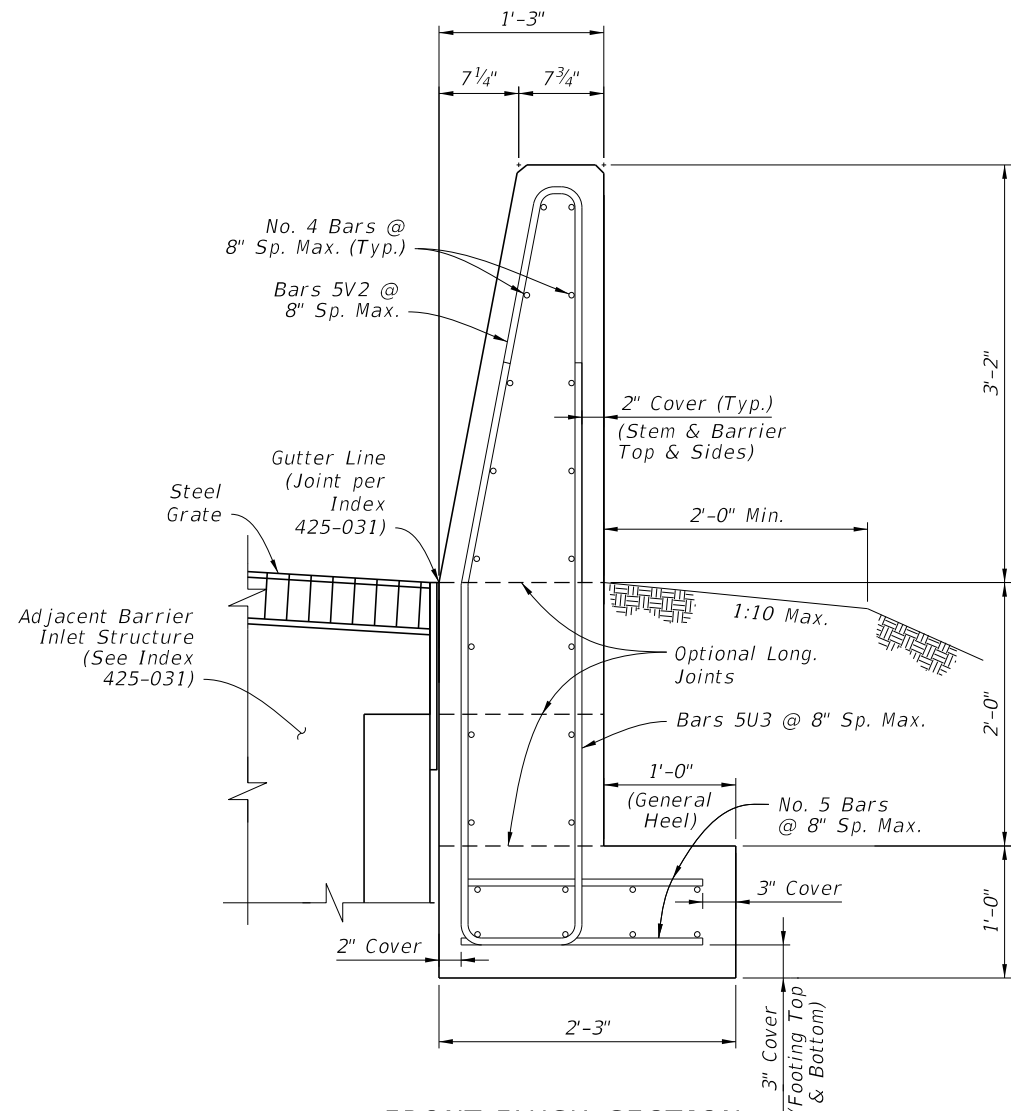

FRONT-FLUSH SECTION
(Where Required For
Barrier Inlet Locations)

Concrete Qty. = 0.29 CY/FT
Steel Qty. = 46.6 LB/FT

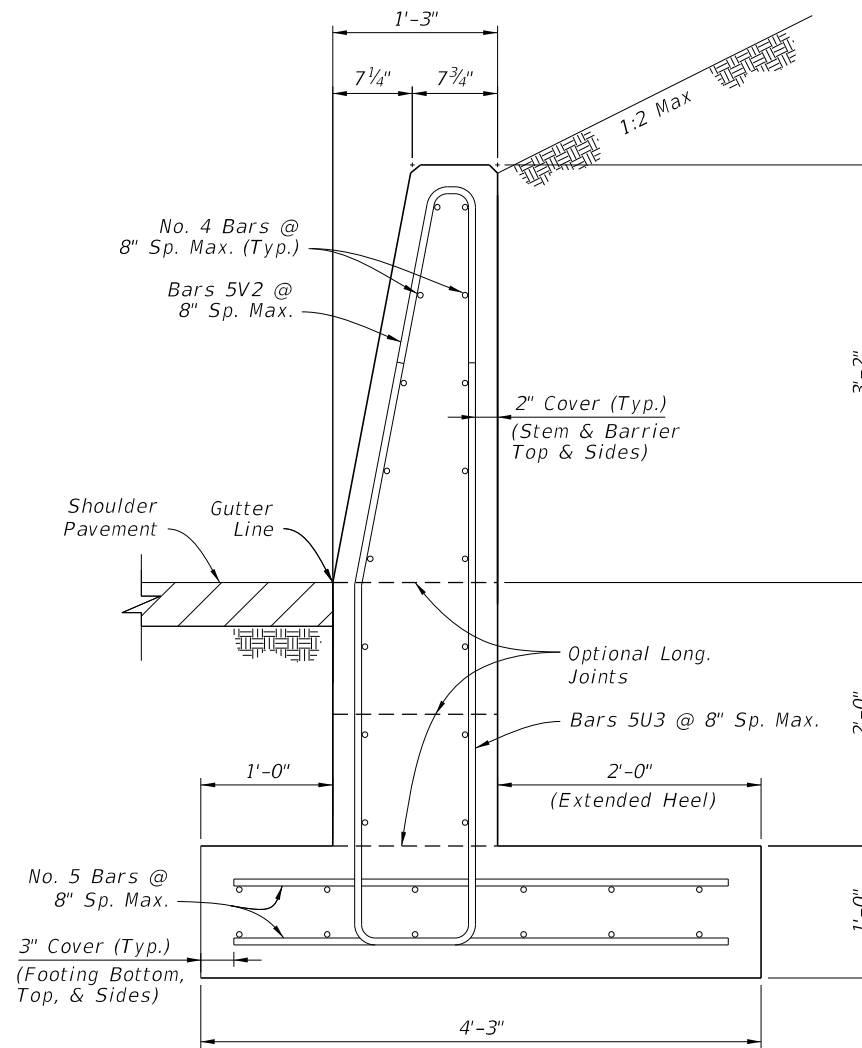

RETAINING SECTION

Concrete Qty. = 0.36 CY/FT
Steel Qty. = 55.3 LB/FT

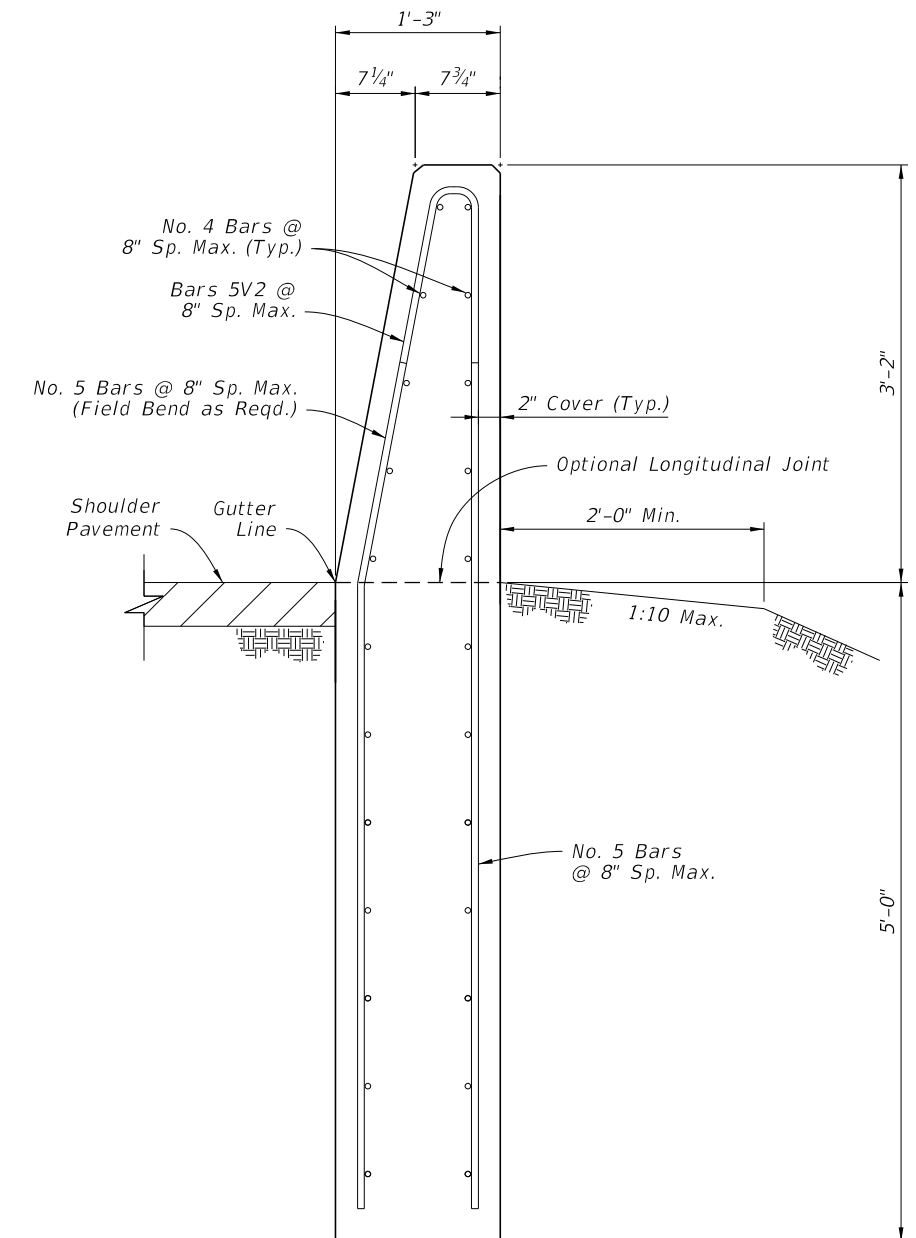

TRENCH FOOTING SECTION

Concrete Qty. = 0.35 CY/FT
Steel Qty. = 46.2 LB/FT

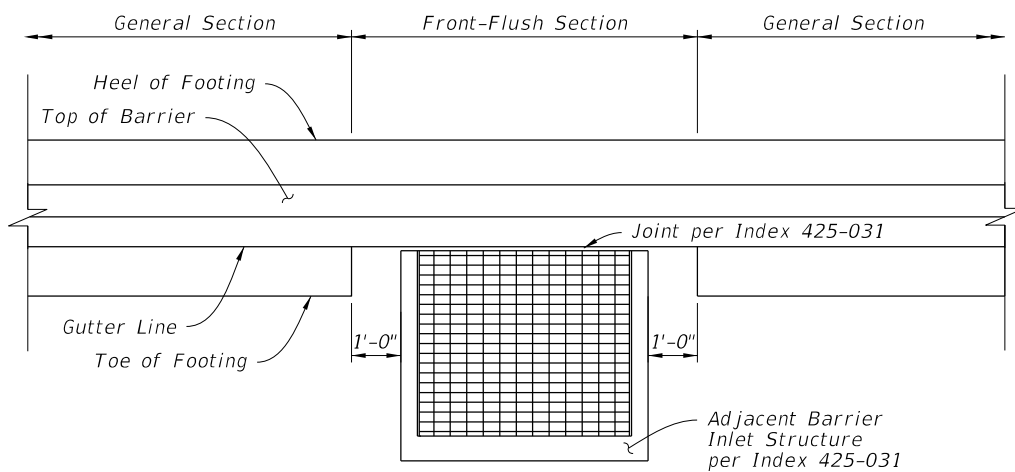

FRONT-FLUSH SECTION - PLAN VIEW
(Not Applicable for Trench Footing Sections)

NOTES:

1. GENERAL: Install the differing Section Options as required per the Plans.
2. CONNECTIONS BETWEEN DIFFERENT SECTIONS: Connect differing Shoulder Barrier sections using a continuous pour or Transverse Joint, where longitudinal steel that aligns within the adjacent section is maintained continuously between sections. Alternatively, a Doweled Joint may be used as shown on Sheet 13.
3. FLUSH RETAINING SECTION COMBINATION: Where Barrier Inlets are required in retaining segments, install the Flush Section, except replace the 1'-0" General Heel with the 2'-0" Extended Heel as shown in the Retaining Section. Use longer lateral reinforcing bars of 2'-10" length to maintain the cover shown.

10/20/2022 8:50:57 AM

LAST REVISION 11/01/19	REVISION	DESCRIPTION:		FY 2023-24 STANDARD PLANS	CONCRETE BARRIER	INDEX 521-001	SHEET 15 of 26
---------------------------	----------	--------------	---	------------------------------	------------------	------------------	-------------------

SHOULDER BARRIER - SECTION OPTIONS

NOTES:

1. GENERAL: See the applicable Notes on Sheet 15.
 2. DRAINAGE SLOT OPTION: Use only where called for in the Plans. Drainage Slots may be used for all Shoulder Barrier types except for the Trench Footing Section.
- Bars 5V2 and 5U3 may exceed 8 inch spacing to accommodate Drainage Slots as shown. Bars 5U3 require pairing on both sides of slots.

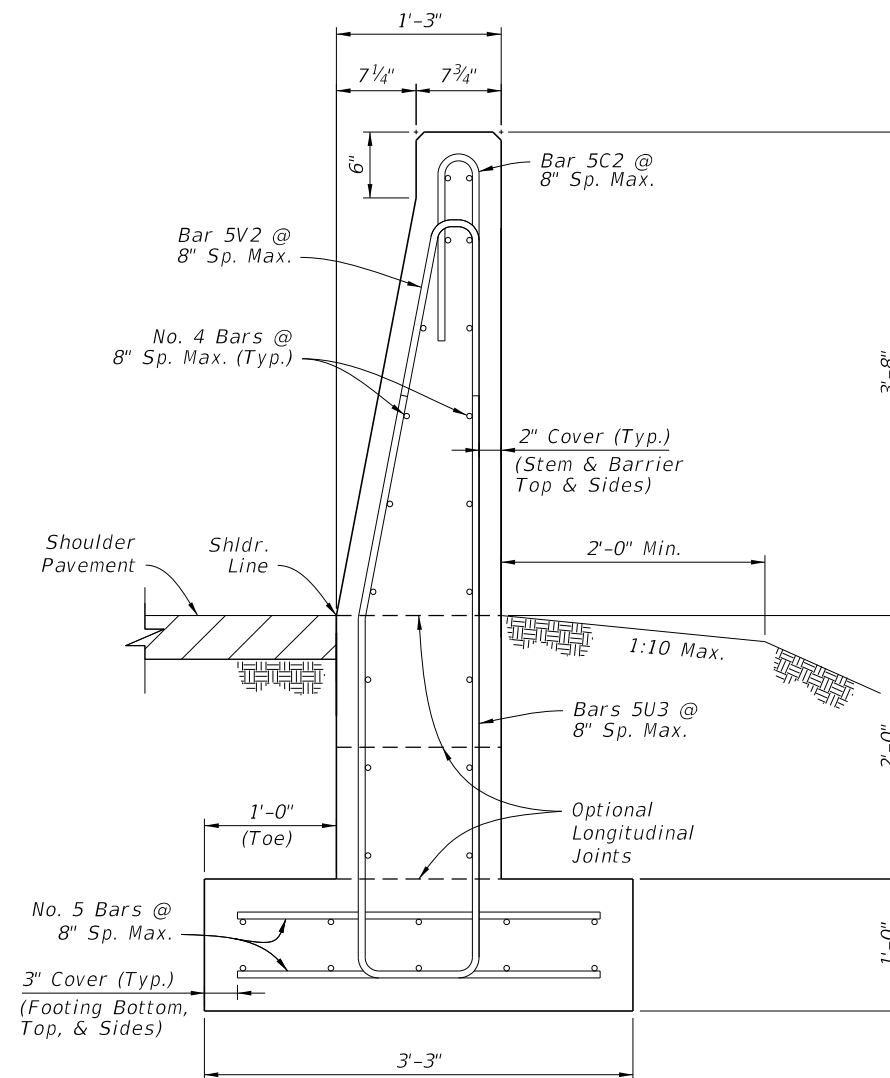

44" HEIGHT SECTION
(For Use Adjacent to Rear-Flush Section on Sheet 18)

Concrete Qty. = 0.34 CY/FT
Steel Qty. = 56.8 LB/FT

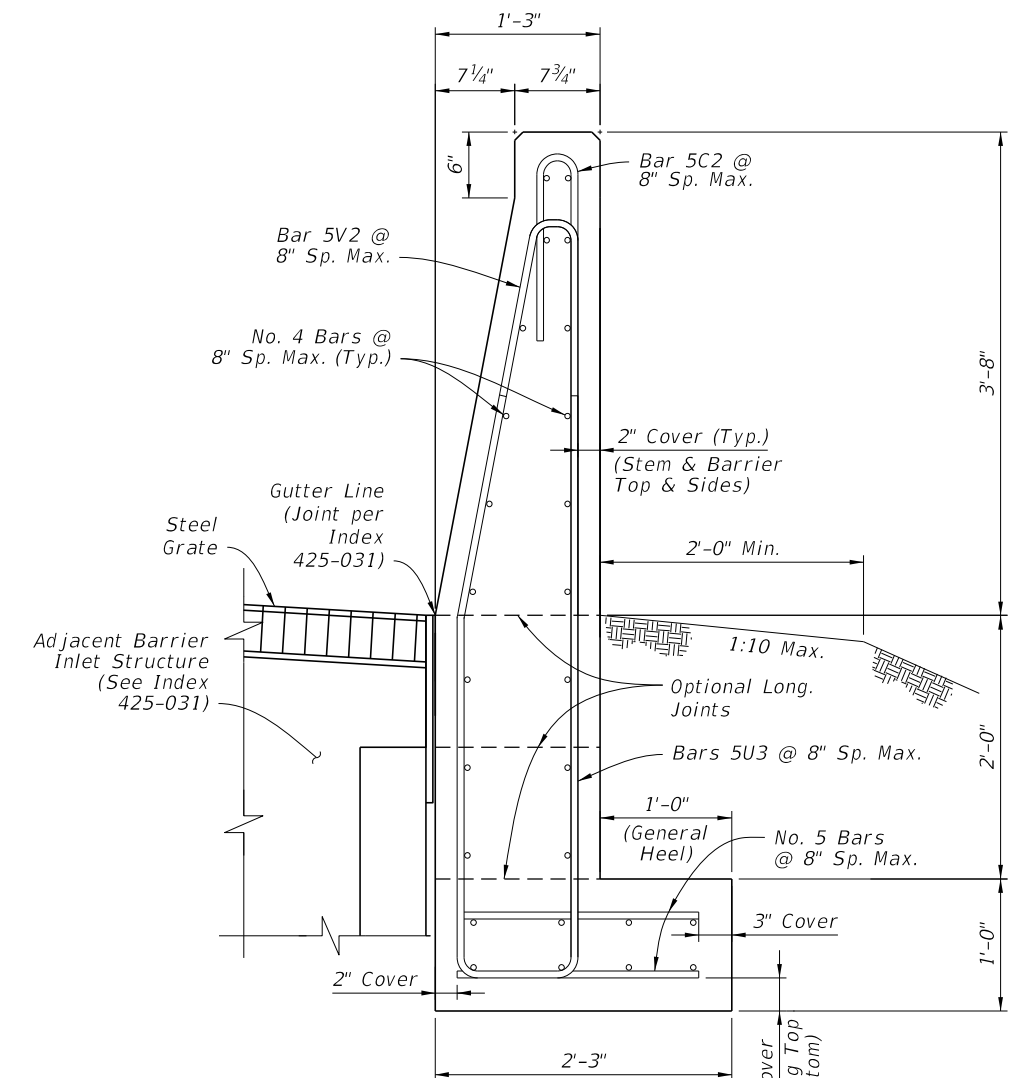

44" HEIGHT FRONT-FLUSH SECTION
(For Use Adjacent to Rear-Flush Section on Sheet 18, as Required for Barrier Inlets)

Concrete Qty. = 0.30 CY/FT
Steel Qty. = 52.6 LB/FT

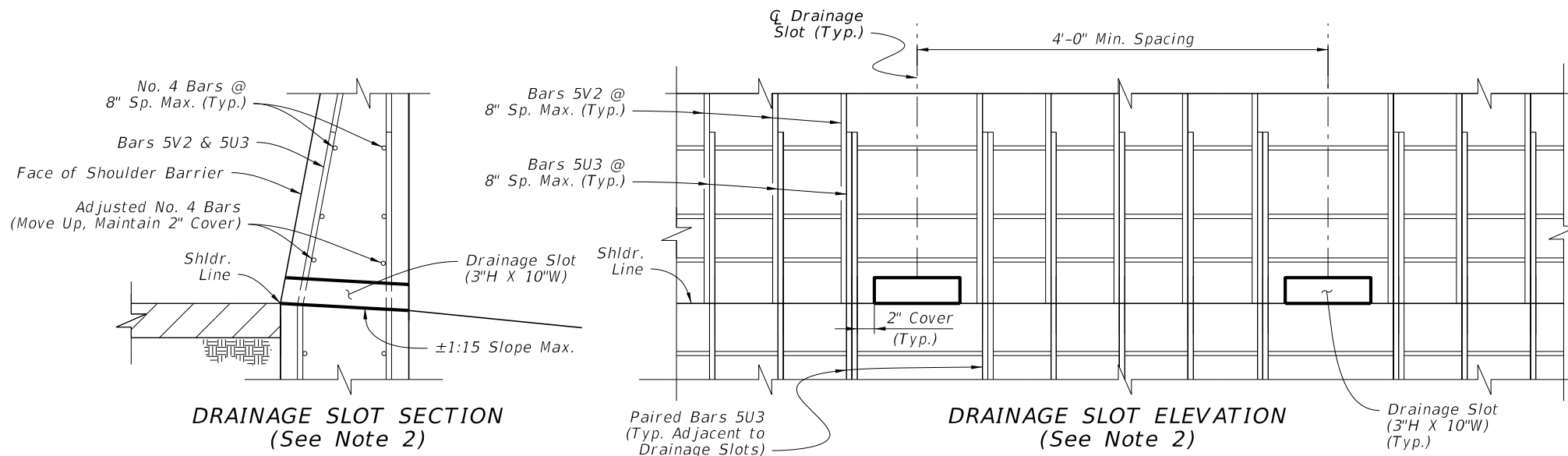

SHOULDER BARRIER - SECTION OPTIONS (CONTINUED)

10/20/2022 8:50:56 AM

LAST REVISION 11/01/20	REVISION	DESCRIPTION:		FY 2023-24 STANDARD PLANS	CONCRETE BARRIER	INDEX 521-001	SHEET 16 of 26
---------------------------	----------	--------------	--	------------------------------	------------------	------------------	-------------------

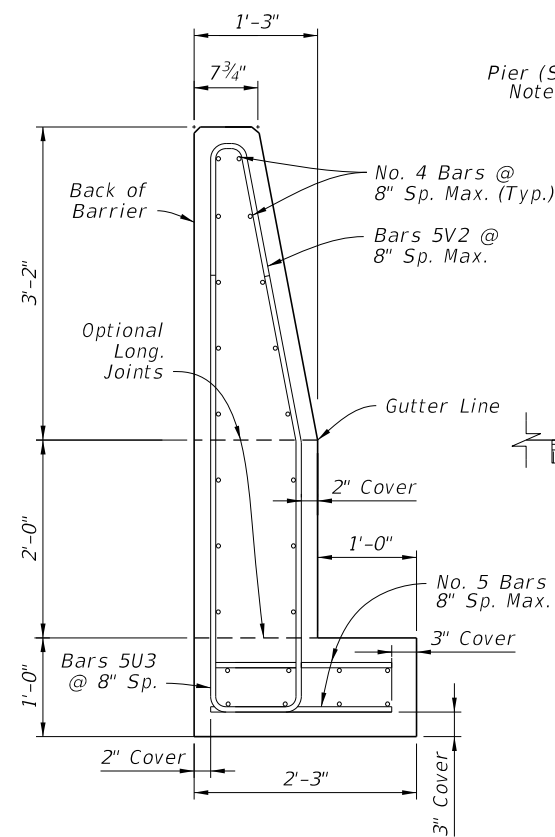

38" HEIGHT REAR-FLUSH SECTION

SECTION A-A ABOVE-GROUND HAZARD EMBEDDED IN FOOTING

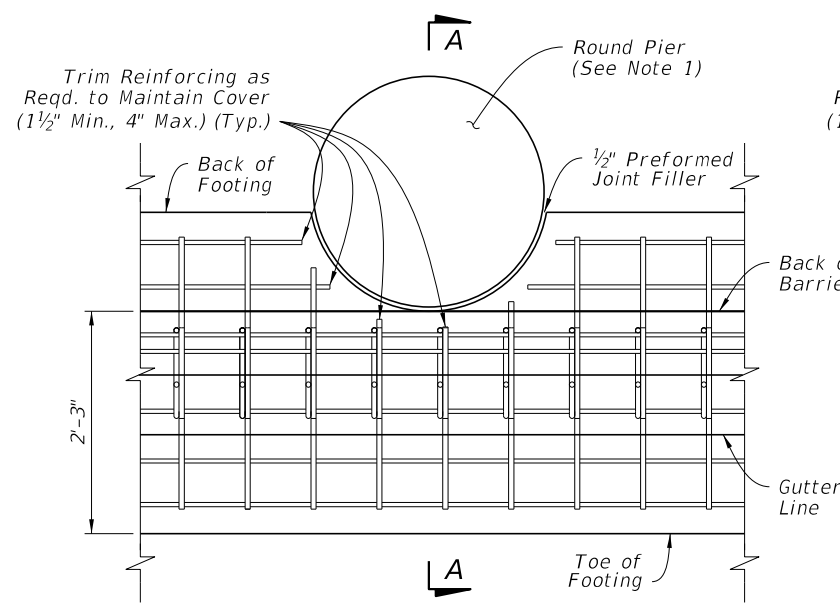

PLAN - ROUND PIER EXAMPLE REAR-FLUSH SECTION
(See Section View for All Longitudinal Steel Locations)

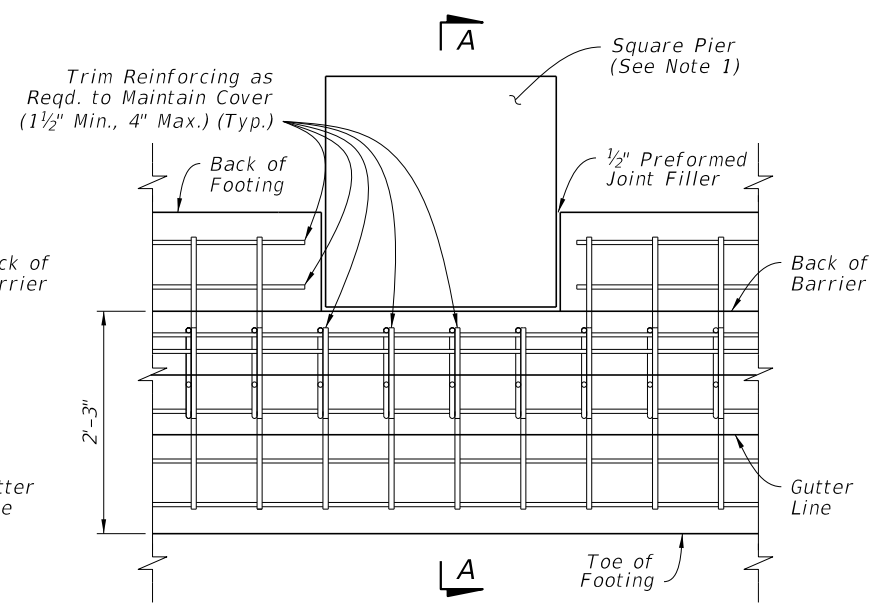

PLAN - SQUARE PIER EXAMPLE REAR-FLUSH SECTION
(See Section View for All Longitudinal Steel Locations)

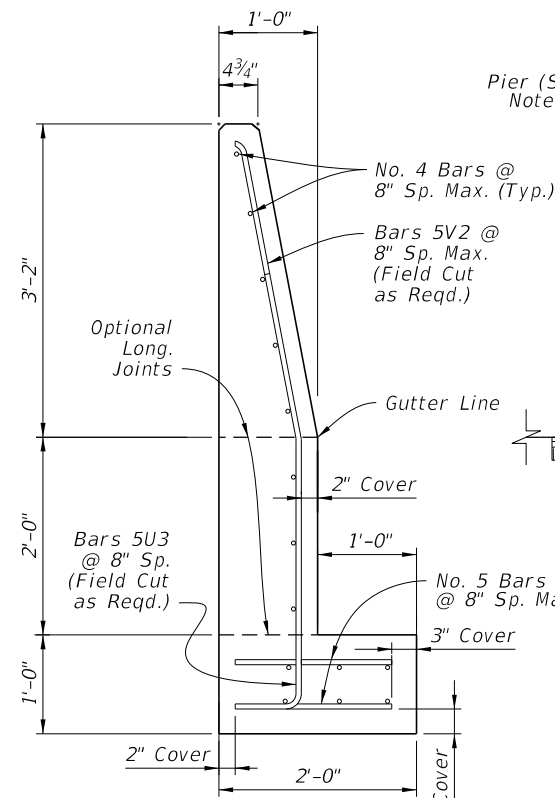

38" HEIGHT REAR-FLUSH SECTION WITH 3" WIDTH REDUCTION

SECTION B-B ABOVE-GROUND HAZARD EMBEDDED IN FOOTING & BARRIER

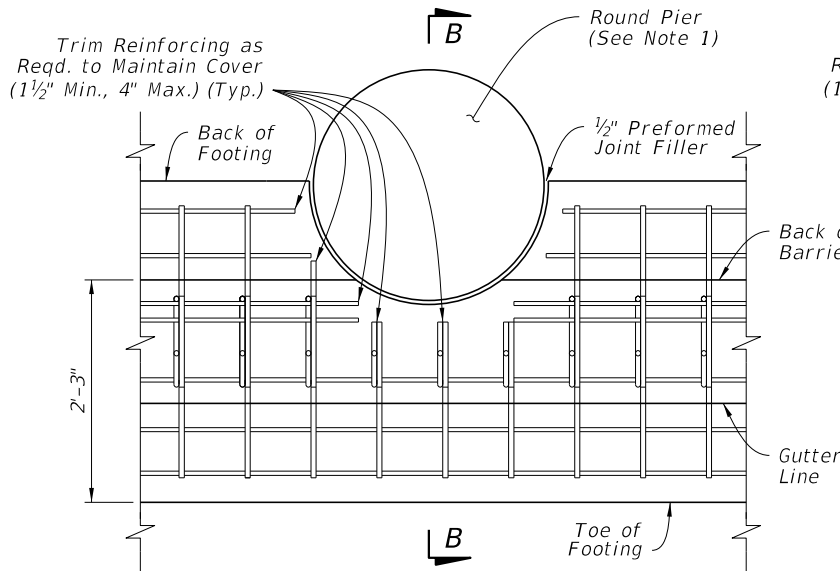

PLAN - ROUND PIER EXAMPLE REAR-FLUSH SECTION WITH 3" WIDTH REDUCTION
(See Section View for All Longitudinal Steel Locations)

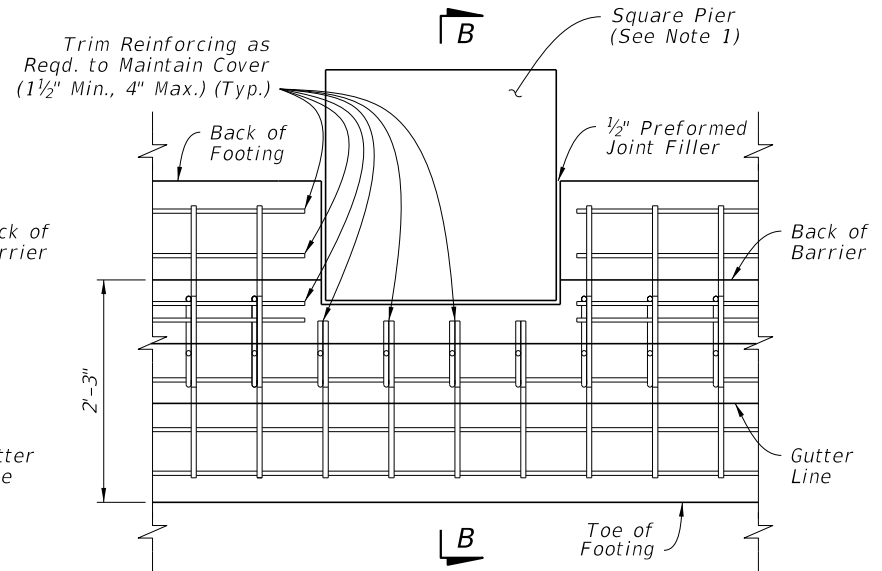

PLAN - SQUARE PIER EXAMPLE REAR-FLUSH SECTION WITH 3" WIDTH REDUCTION
(See Section View for All Longitudinal Steel Locations)

NOTE:

1. PIERS: The piers shown herein are example shapes only; see the Plans for the project-specific dimensions. The details shown herein are only for use when piers do not require protection per the AASHTO LRFD requirements. For piers requiring protection, see Index 521-002.

SHOULDER BARRIER - 38" HEIGHT REAR-FLUSH SECTION FOR REDUCED SETBACK PIER SHIELDING (DESIGN SPEED ≤ 45 MPH)

10/20/2022 8:50:58 AM

LAST REVISION	DESCRIPTION:
11/01/18	



**FY 2023-24
STANDARD PLANS**

CONCRETE BARRIER

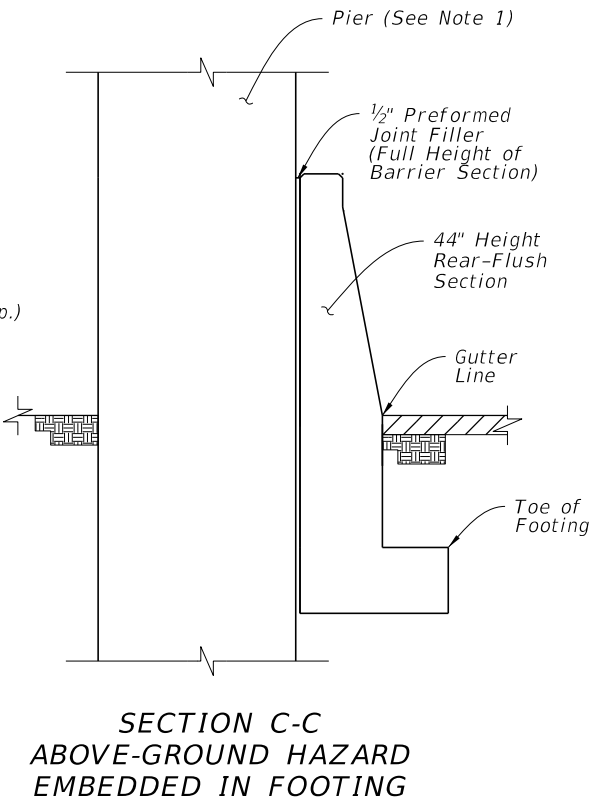
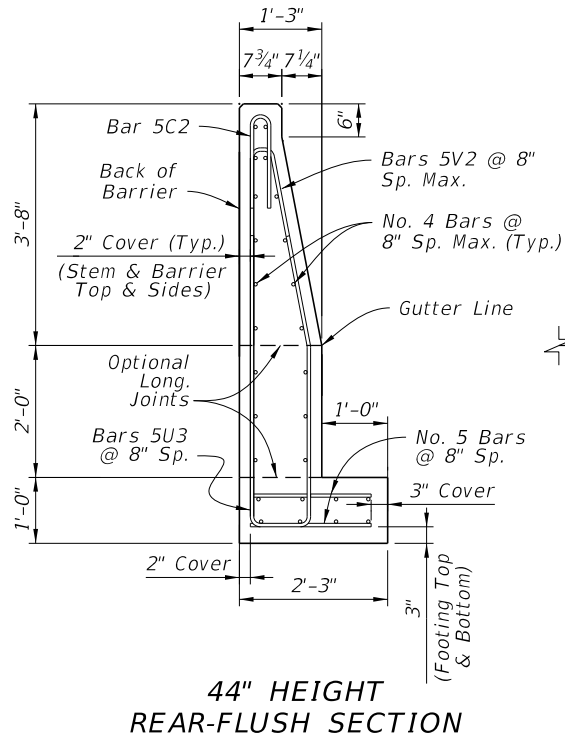
INDEX	SHEET
521-001	17 of 26

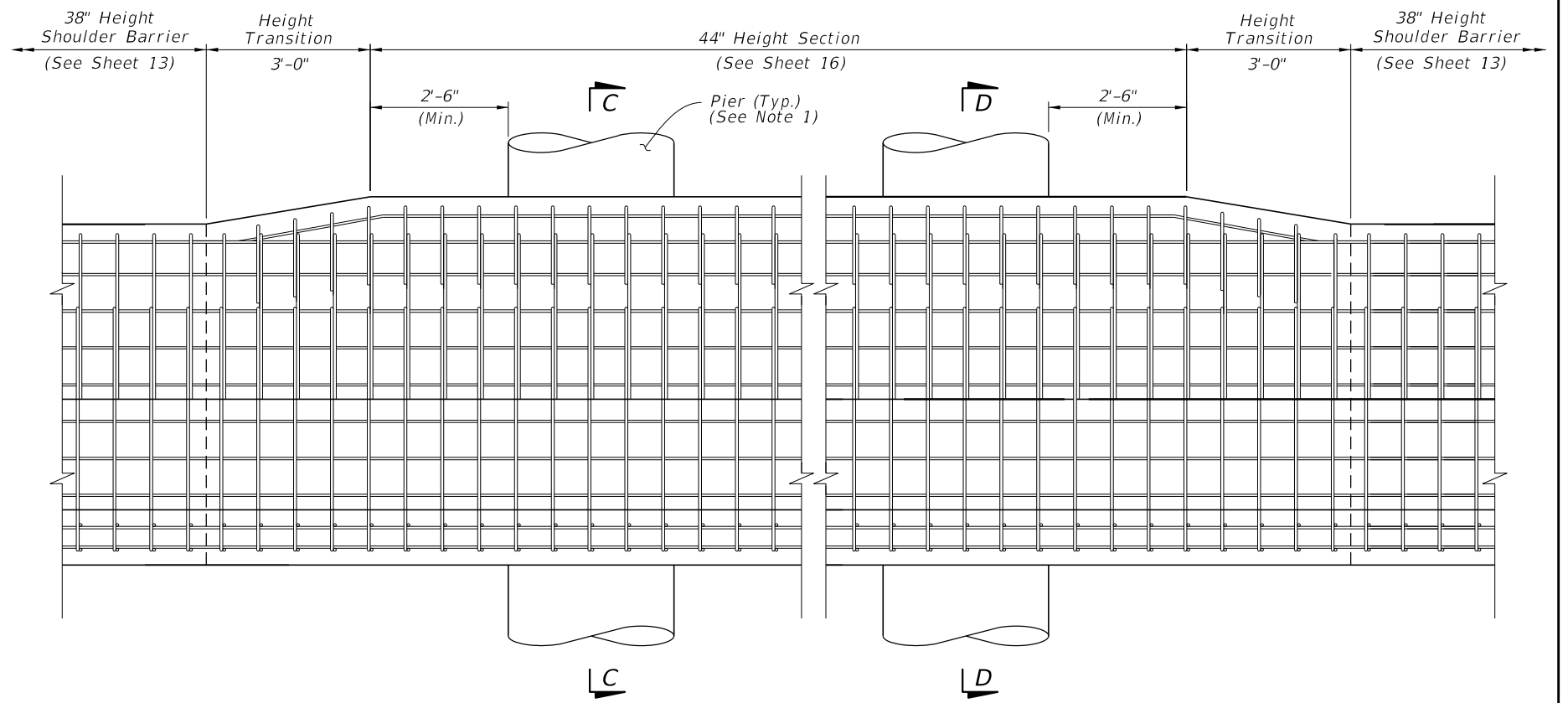

**SECTION C-C
ABOVE-GROUND HAZARD
EMBEDDED IN FOOTING**



**ELEVATION - ROUND PIERS EXAMPLE
(SQUARE PIERS SIMILAR)**

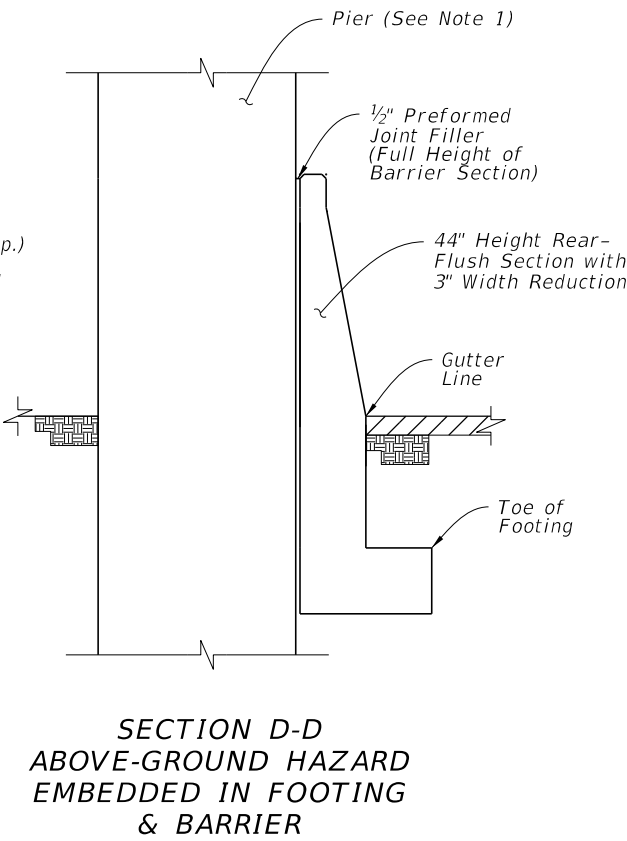
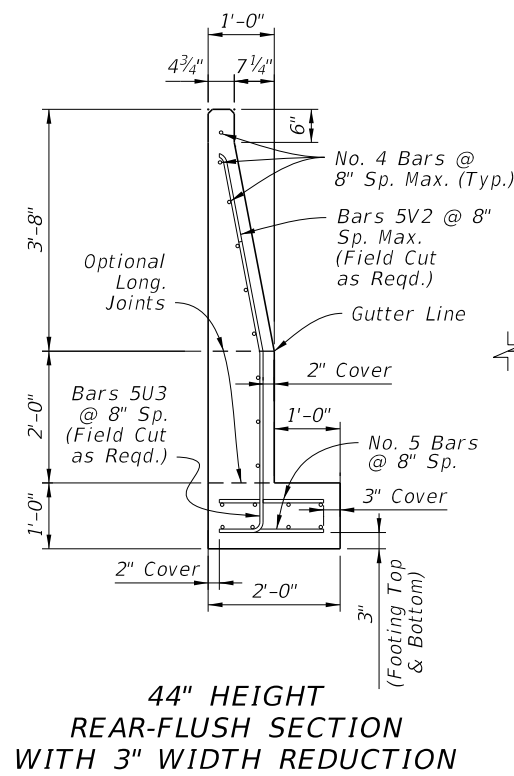

**SECTION D-D
ABOVE-GROUND HAZARD
EMBEDDED IN FOOTING
& BARRIER**

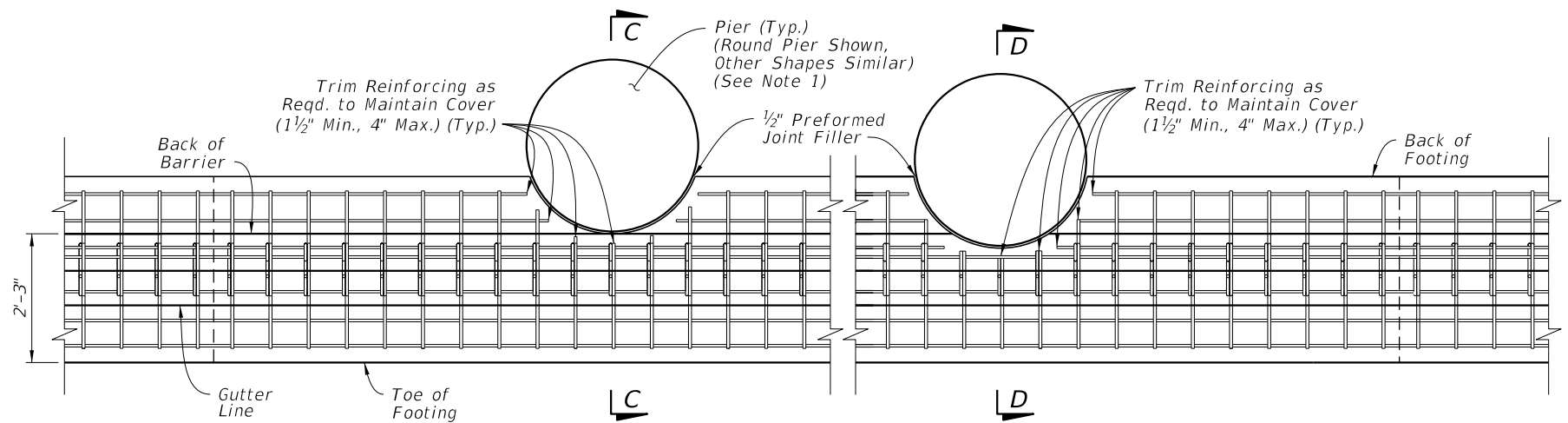

**PLAN - ROUND PIERS EXAMPLE
(SQUARE PIERS SIMILAR)
(For All Longitudinal Steel Locations,
See the Section Views)**

NOTE:
1. PIERS: The piers shown herein are example shapes only; see the Plans for the project-specific dimensions. The details shown herein are only for use when piers do not require protection per the AASHTO LRFD requirements. For piers requiring protection, see Index 521-002.

**SHOULDER BARRIER - 44" HEIGHT REAR-FLUSH
SECTION FOR REDUCED SETBACK PIER SHIELDING**

10/20/2022 8:50:59 AM

LAST REVISION 11/01/18	DESCRIPTION:		FY 2023-24 STANDARD PLANS	CONCRETE BARRIER	INDEX	SHEET
					521-001	18 of 26

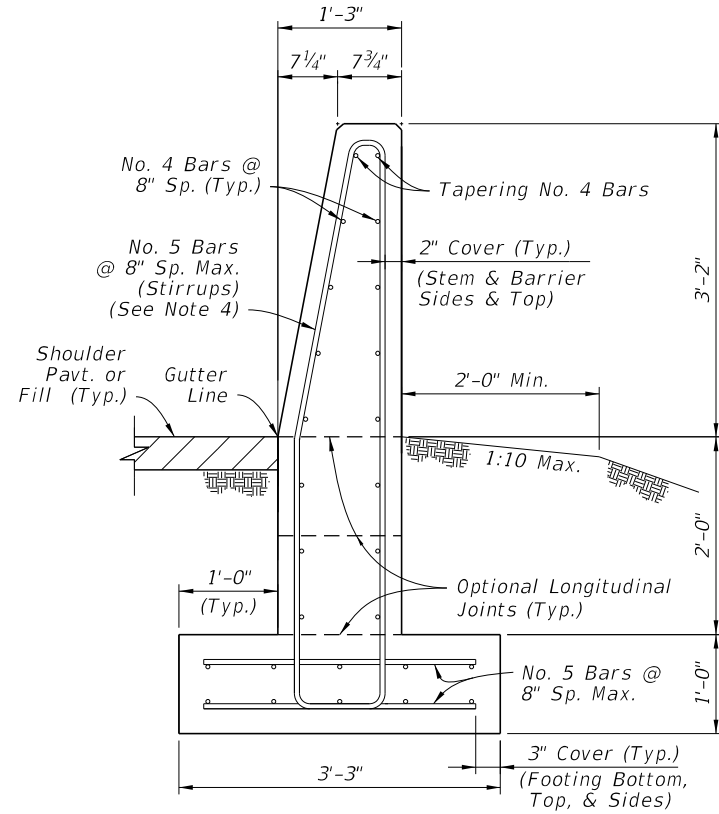

**SECTION A-A
BEGIN TRANSITION - OPTION 'A'
MATCH SINGLE-SLOPE
38" HEIGHT SHOULDER BARRIER**

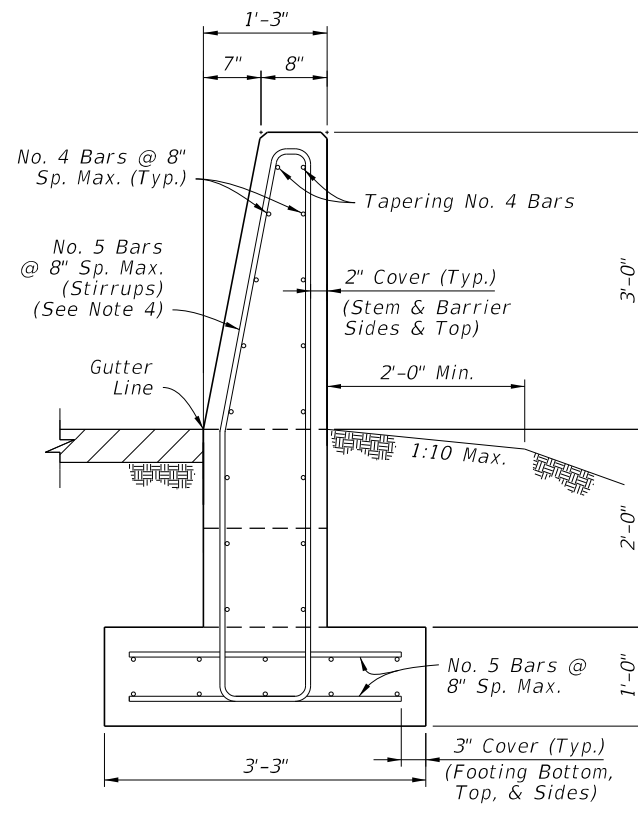

**SECTION A-A
BEGIN TRANSITION - OPTION 'B'
MATCH SINGLE-SLOPE
36" HEIGHT TRAFFIC RAILING
(Bridge Applications)**

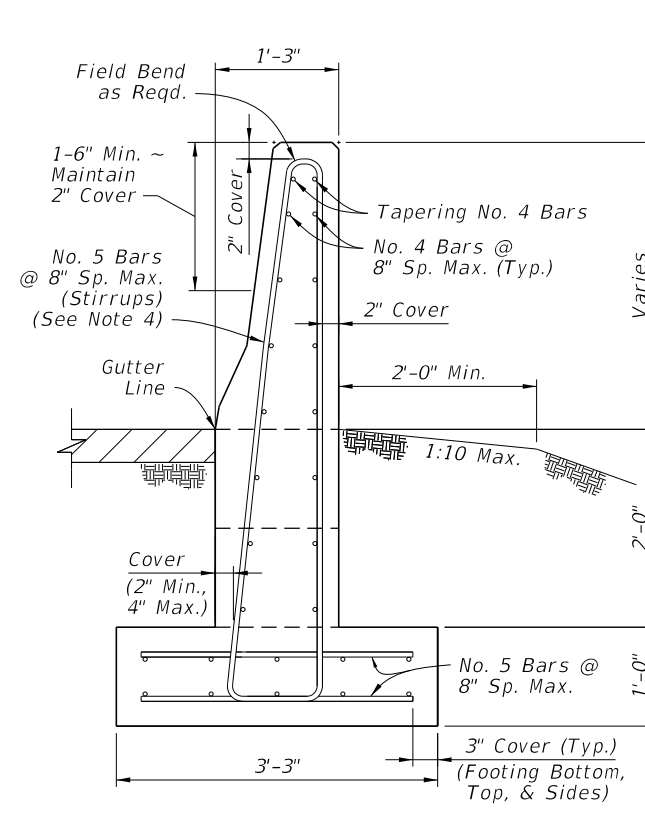

**SECTION B-B
INTERMEDIATE SECTION
OF LINEAR TRANSITION**

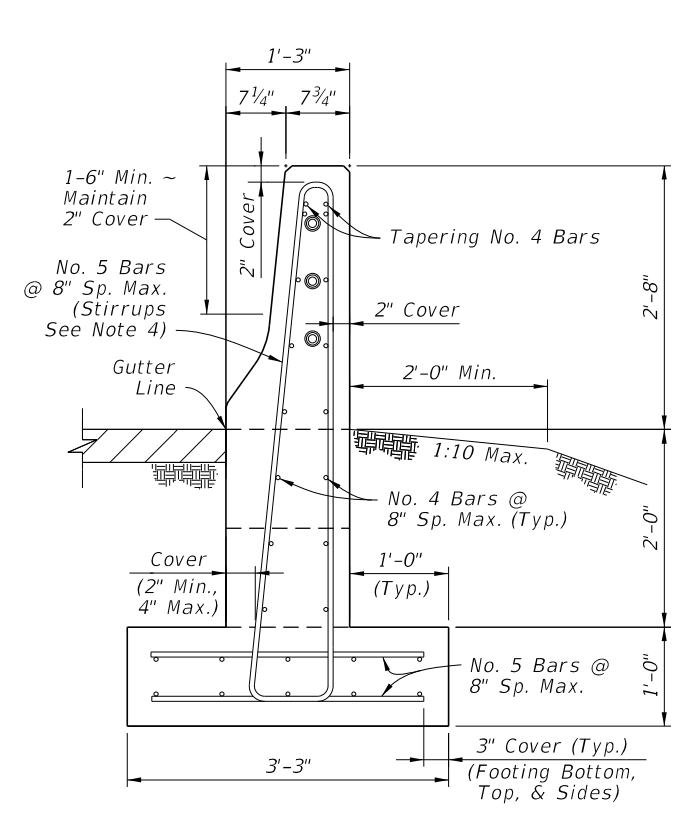

**SECTION C-C
END TRANSITION
MATCH 32" HEIGHT
F-SHAPE SECTION**

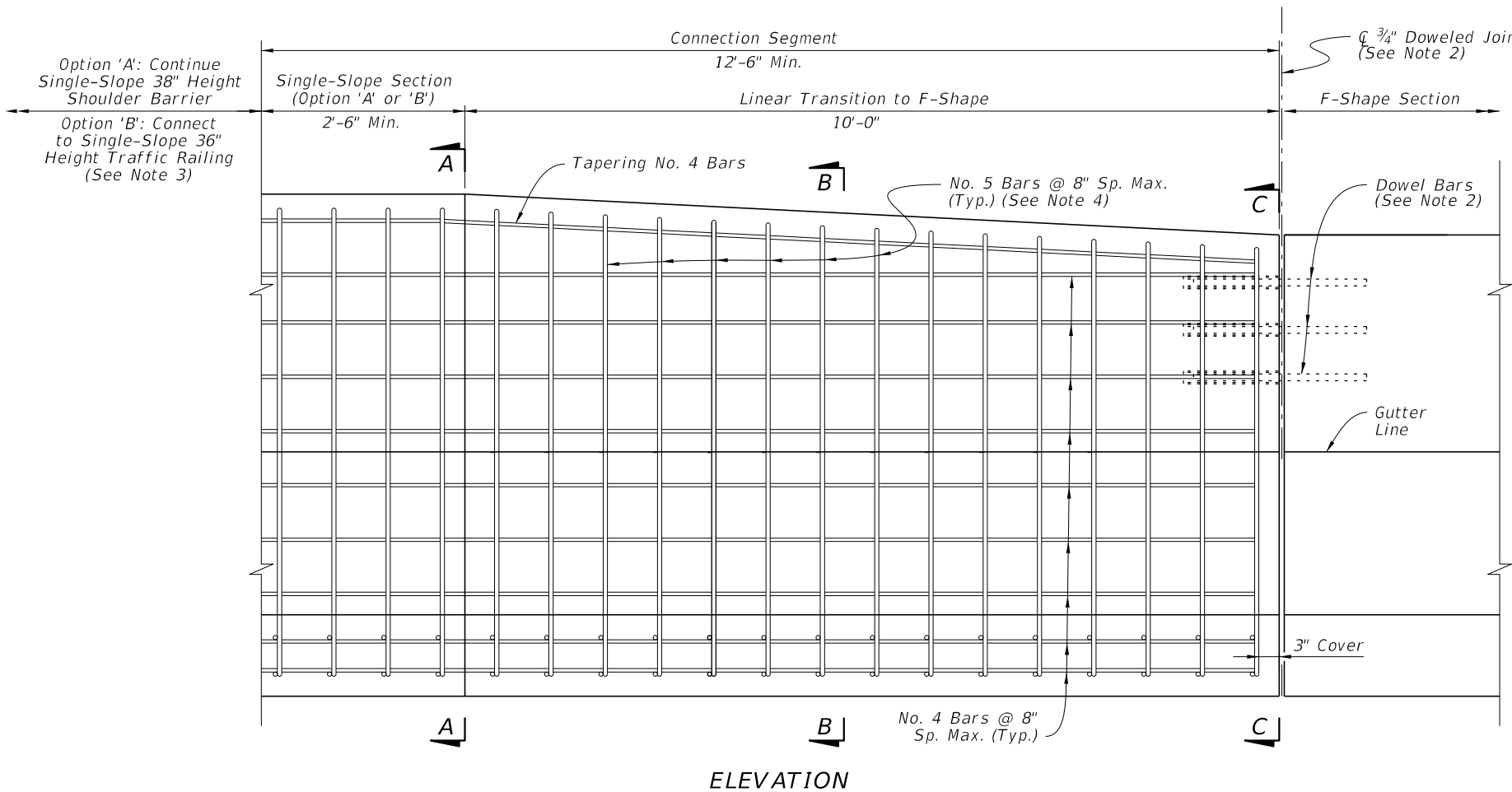

ELEVATION

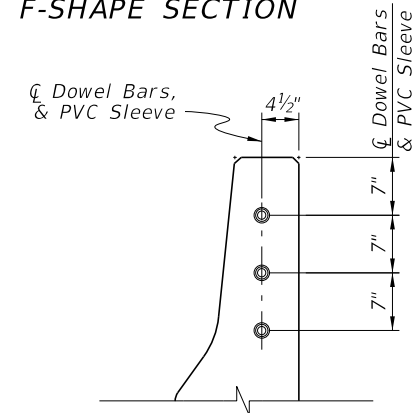

**SECTION - F-SHAPE
DOWEL PLACEMENT
(See Note 2)**

NOTES:

1. GENERAL: Construct the Connection Segment as required per the Plans to connect existing F-Shape sections to Single-Slope Shoulder Barrier or Traffic Railing sections. Construct Option 'A' or 'B' as required to match the heights of the connecting sections.
2. DOWELED JOINT: Install Dowel Bars per the Dowel Details on Sheet 13.
3. TRAFFIC RAILING CONNECTION: For the Option 'B' connection, use a Doweled Joint per Sheet 13 and the additional Free End Reinforcing with reduced bar spacing per Sheet 14.
4. STIRRUP BARS: For the vertical and transverse reinforcement requirements shown, bar bending diagrams are not provided due to varying section dimensions. Use any combination of spliced reinforcing steel to position the reinforcement with the same cover, spacing, continuity, and equivalent strength shown herein, as approved by the Engineer.

SHOULDER BARRIER - CONNECTION TO F-SHAPE

10/20/2022 8:51:00 AM

LAST REVISION 11/01/22	DESCRIPTION:		FY 2023-24 STANDARD PLANS	CONCRETE BARRIER	INDEX	SHEET
			521-001		19 of 26	

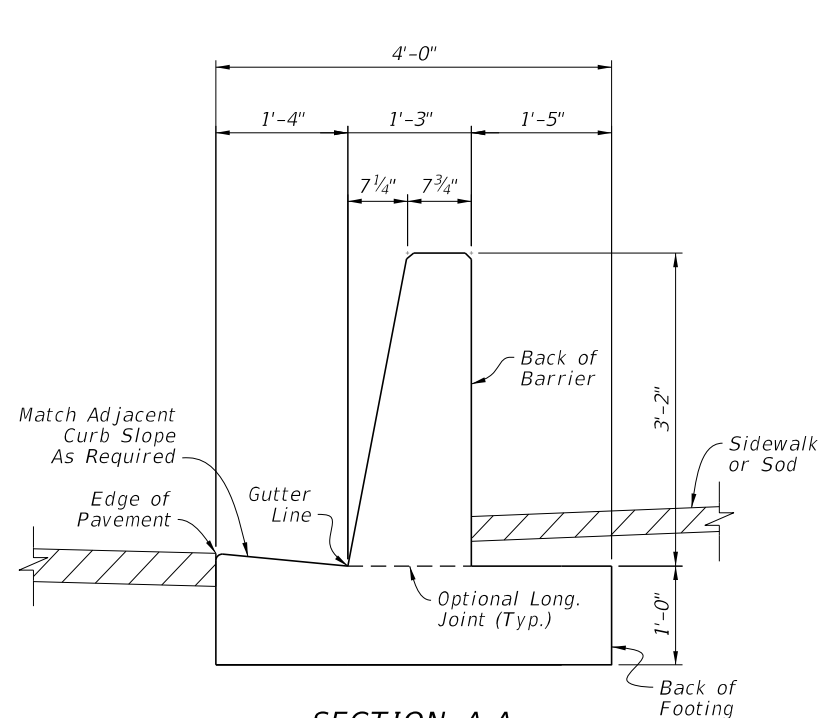

**SECTION A-A
CURB & GUTTER
BARRIER**

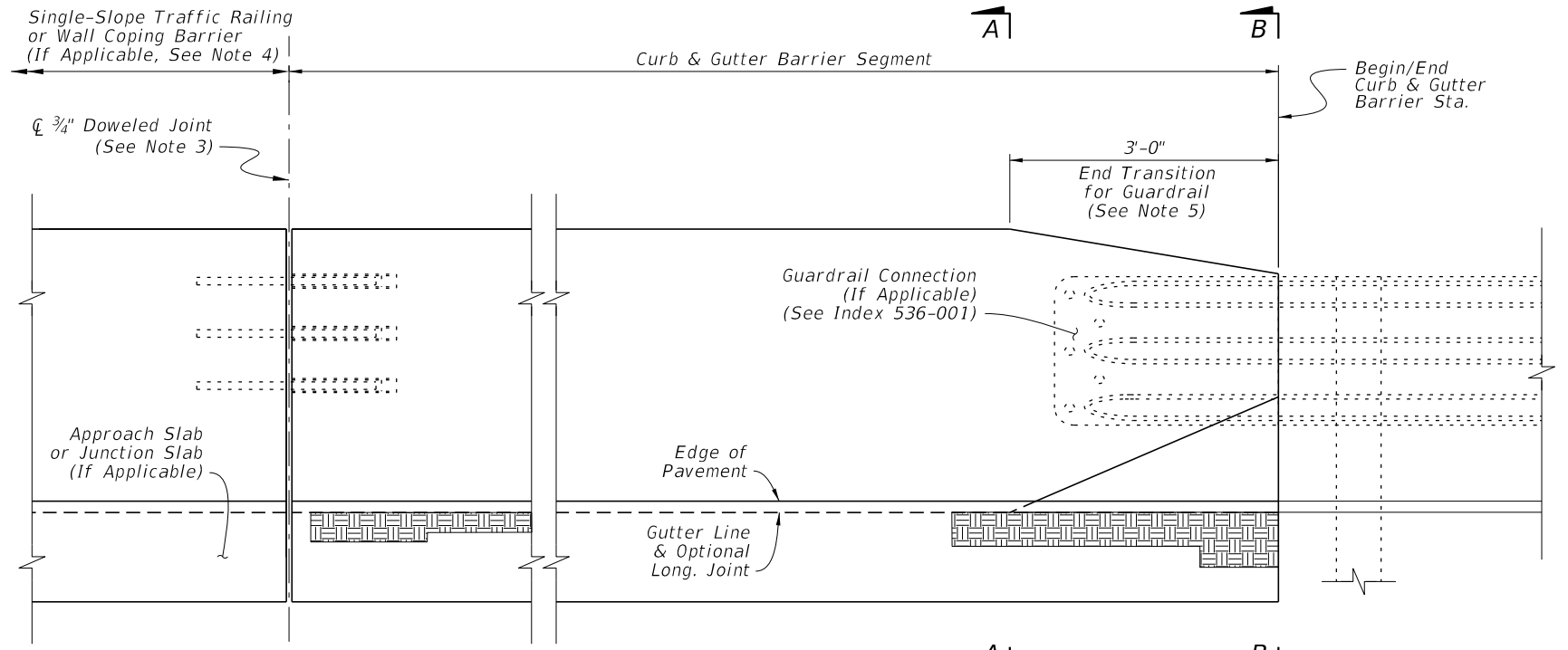

ELEVATION

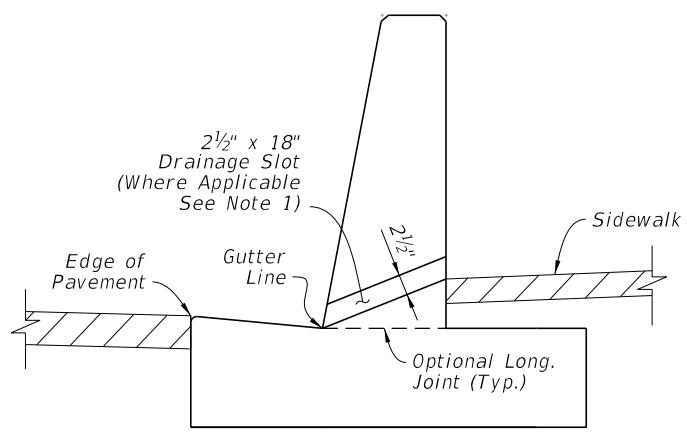

**SECTION C-C
CURB & GUTTER
BARRIER WITH
DRAINAGE SLOT**

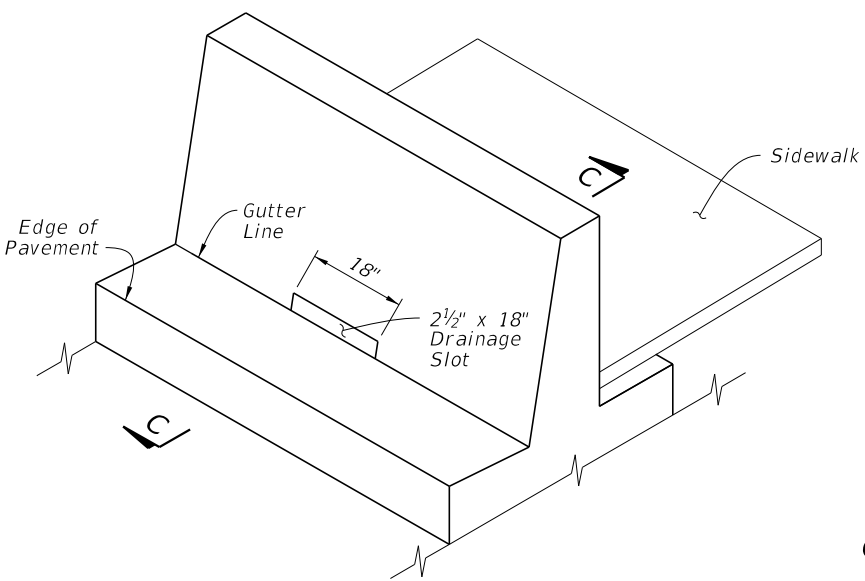

**ISOMETRIC VIEW
CURB GUTTER BARRIER
WITH DRAINAGE SLOT**

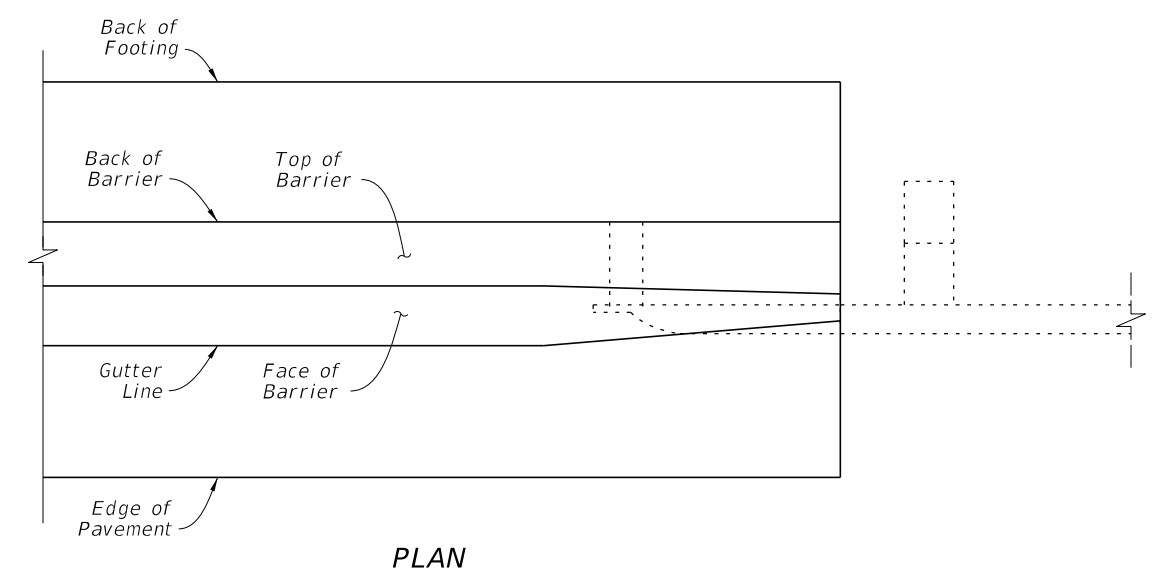

PLAN

CURB AND GUTTER BARRIER NOTES:

1. SECTION VIEWS: For additional Views A-A and B-B, see Sheet 21.
2. EXPANSION JOINTS: Place 1/2" width transverse expansion joints through the barrier and footing spaced at 100-foot maximum intervals. On both sides of each joint, use the Free End Reinforcing bar spacing per Sheet 21.
3. DOWELED JOINTS: See the General Notes on Sheet 1 for usage of joint types. Where required, install 3/4" Doweled Joints as defined on Sheet 13.
4. TRAFFIC RAILING CONNECTIONS: Align the barrier and Traffic Railing faces and connect with the 3/4" Doweled Joint per Sheet 13.
5. GUARDRAIL CONNECTIONS: Connect Guardrail using the Transition Connections to Rigid Barrier per Index 536-001 in conjunction with 3'-0" End Transition for Guardrail as shown herein.
6. FREE ENDS: When the barrier end does not terminate with a Traffic Railing connection or Guardrail connection as called for in the Plans, terminate the barrier in accordance with the Free End Reinforcing Note on Sheet 21.

DRAINAGE SLOT NOTES:

1. GENERAL: Place 2 1/2" x 18" Drainage Slots at locations and/or spacing called for in the Plans. The minimum spacing is 20 feet.
2. STEEL REINFORCEMENT CONFLICT: When the Drainage Slot encounters a conflict with reinforcing steel, shift or cut the reinforcing steel to provide 2 1/2" (± 1/2") of concrete cover for the reinforcing around the Drainage Slot. If cutting the vertical bars, maintain 8" bar spacing. If shifting the vertical bars, move the bars from the standard 8" spacing location to the closest end of the drainage slot (distributing additional vertical reinforcement evenly on each side of the Drainage Slot).

DRAINAGE SLOT DETAILS

CURB AND GUTTER BARRIER

10/20/2022 8:51:01 AM

LAST REVISION 11/01/22	REVISION	DESCRIPTION:		FY 2023-24 STANDARD PLANS	CONCRETE BARRIER	INDEX	SHEET
						521-001	20 of 26

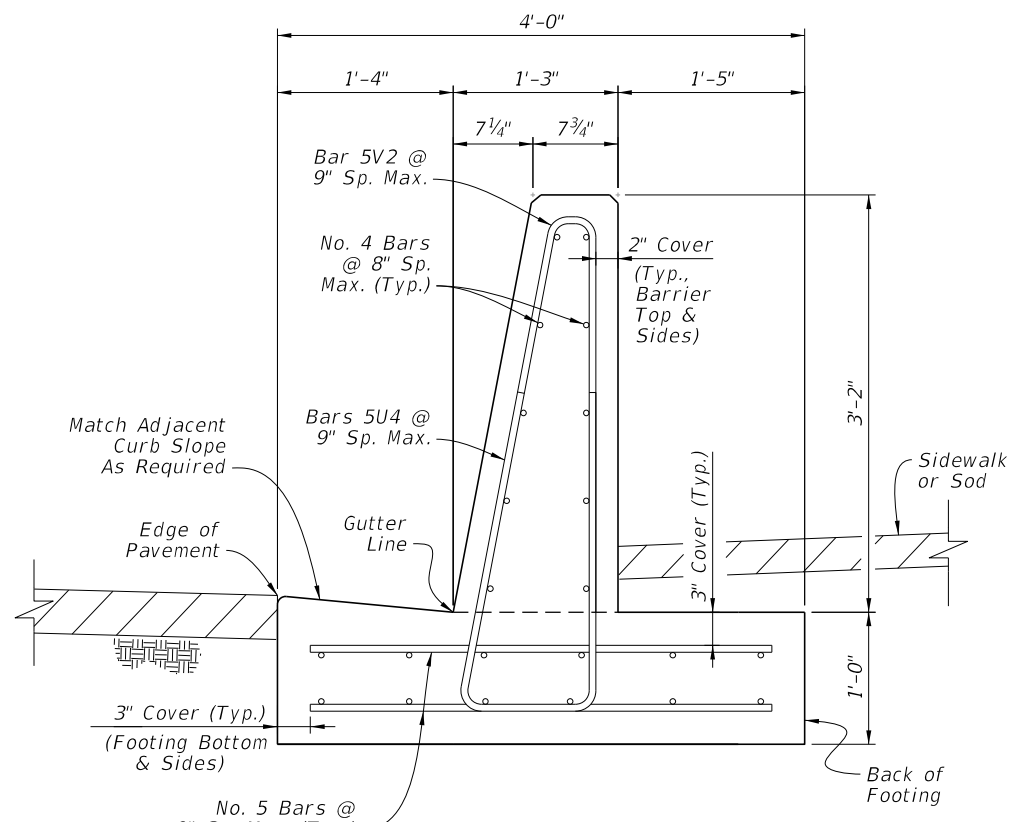

**SECTION A-A
CURB & GUTTER
BARRIER**

Concrete Qty. = 0.26 CY/FT
Steel Qty. = 41.2 LB/FT

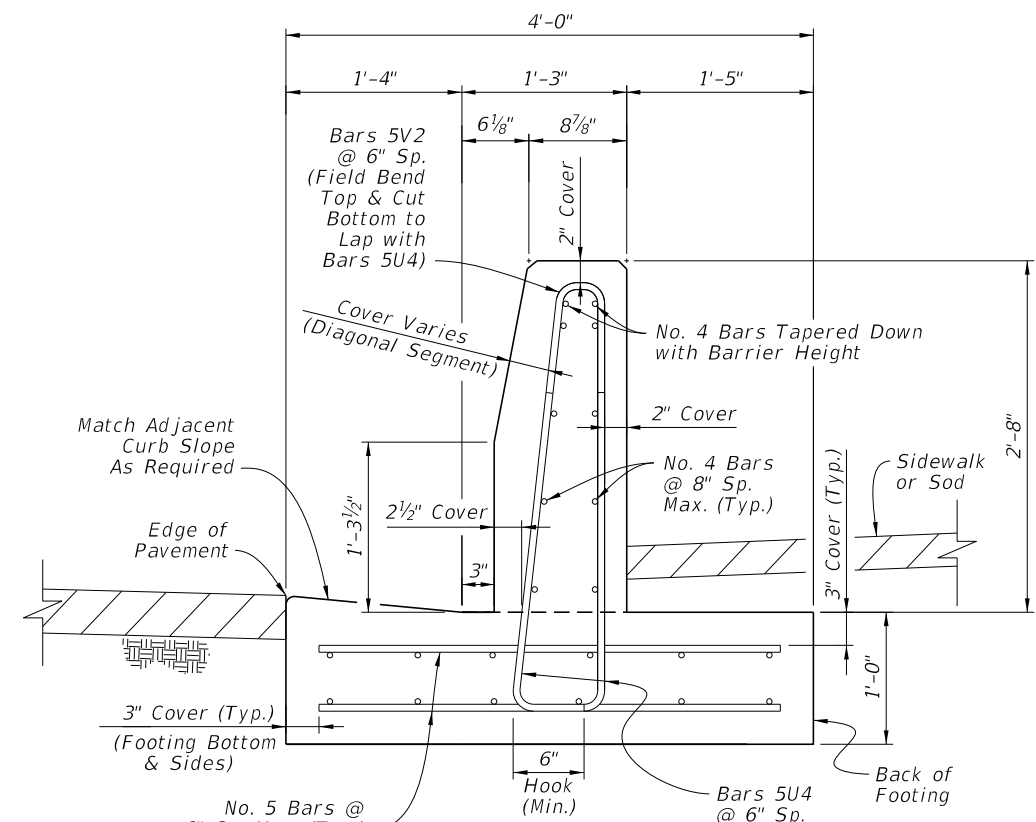

**VIEW B-B
END OF
TRANSITION
FOR GUARDRAIL**

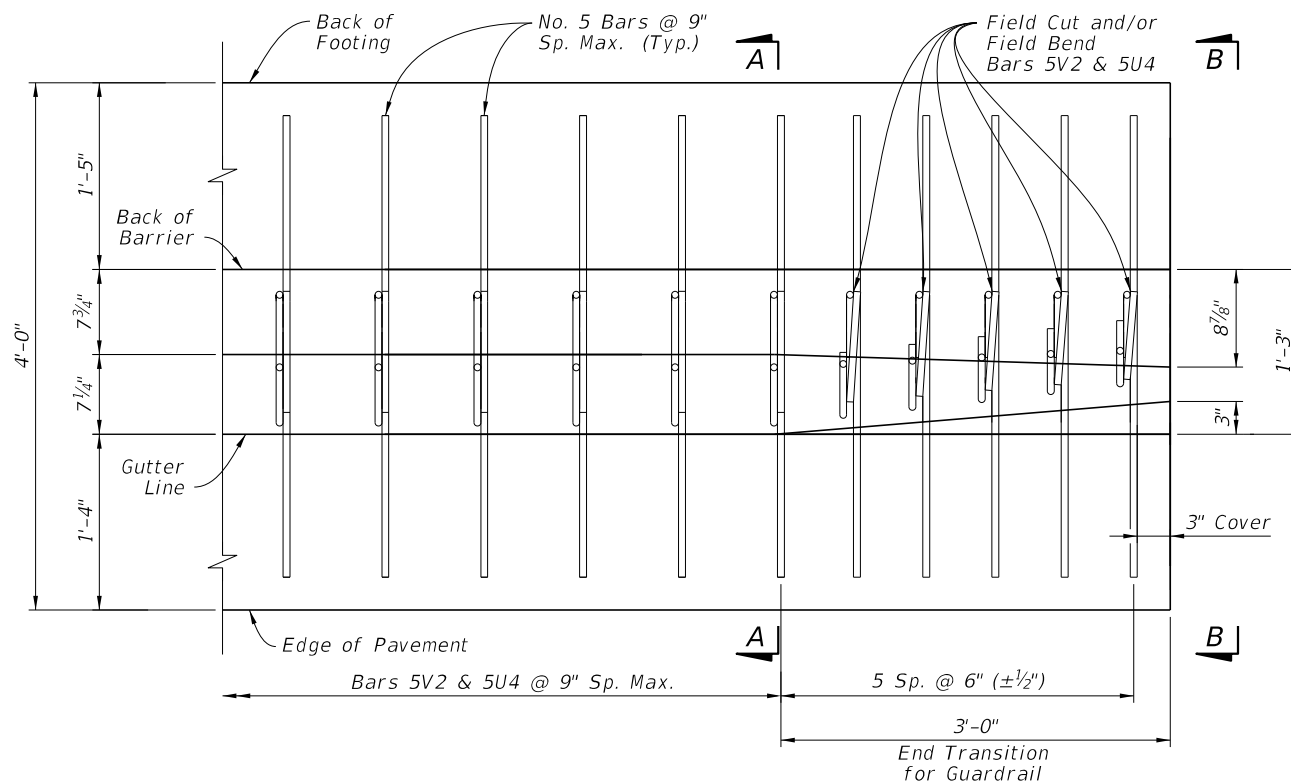

PLAN VIEW - END SEGMENT FOR GUARDRAIL CONNECTION
(Longitudinal Steel Not Shown for Clarity)

NOTES:

1. GENERAL: Work with the Plan and Elevation Views on Sheet 20.
2. FREE END REINFORCING: Where shown in the Plans, terminate the 38" Curb & Gutter Barrier section with a transverse vertical end face. Reduce the spacing of Bars 5V2 and 5U4 to 6" for 5 Spaces, placed with 3" cover from the barrier's end face.
3. BAR BENDING DIAGRAMS: For additional details for bars 5V2 and 5U4, see the Bar Bending Diagrams on Sheet 26.

**CURB AND GUTTER BARRIER -
REINFORCING DETAILS**

10/20/2022 8:51:02 AM

LAST REVISION 11/01/18	REVISION	DESCRIPTION:	 FY 2023-24 STANDARD PLANS	CONCRETE BARRIER	INDEX 521-001	SHEET 21 of 26
---------------------------	----------	--------------	---	------------------	------------------	-------------------

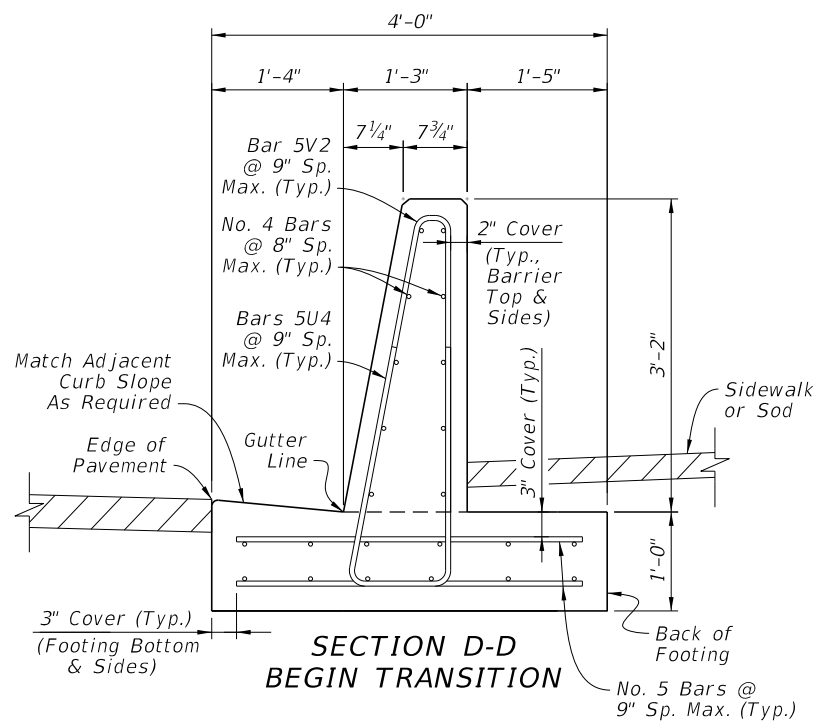

**SECTION D-D
BEGIN TRANSITION**

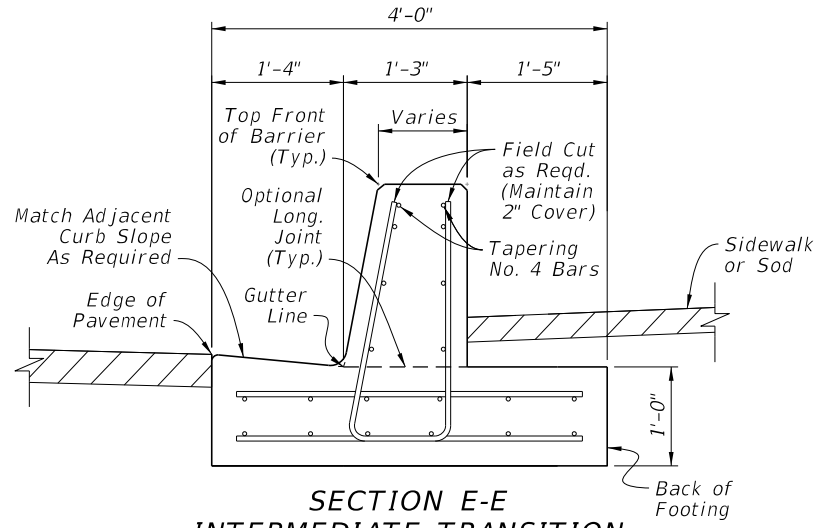

**SECTION E-E
INTERMEDIATE TRANSITION
(Height Varies Linearly
Per Elevation View)**

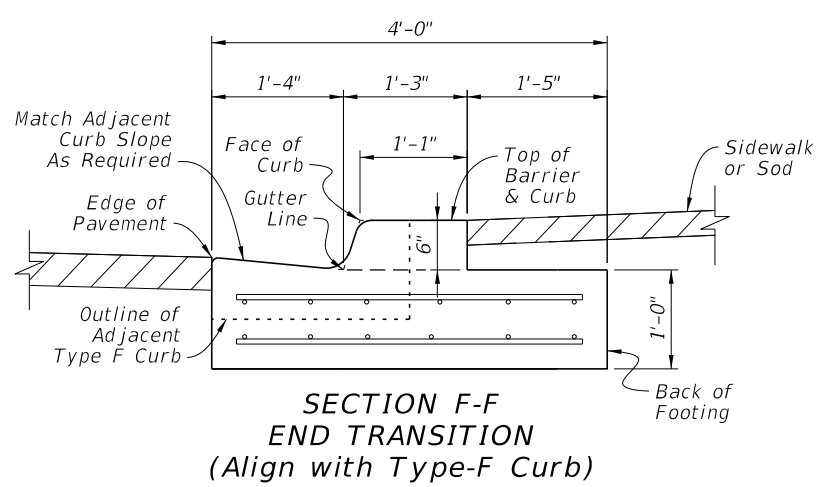

**SECTION F-F
END TRANSITION
(Align with Type-F Curb)**

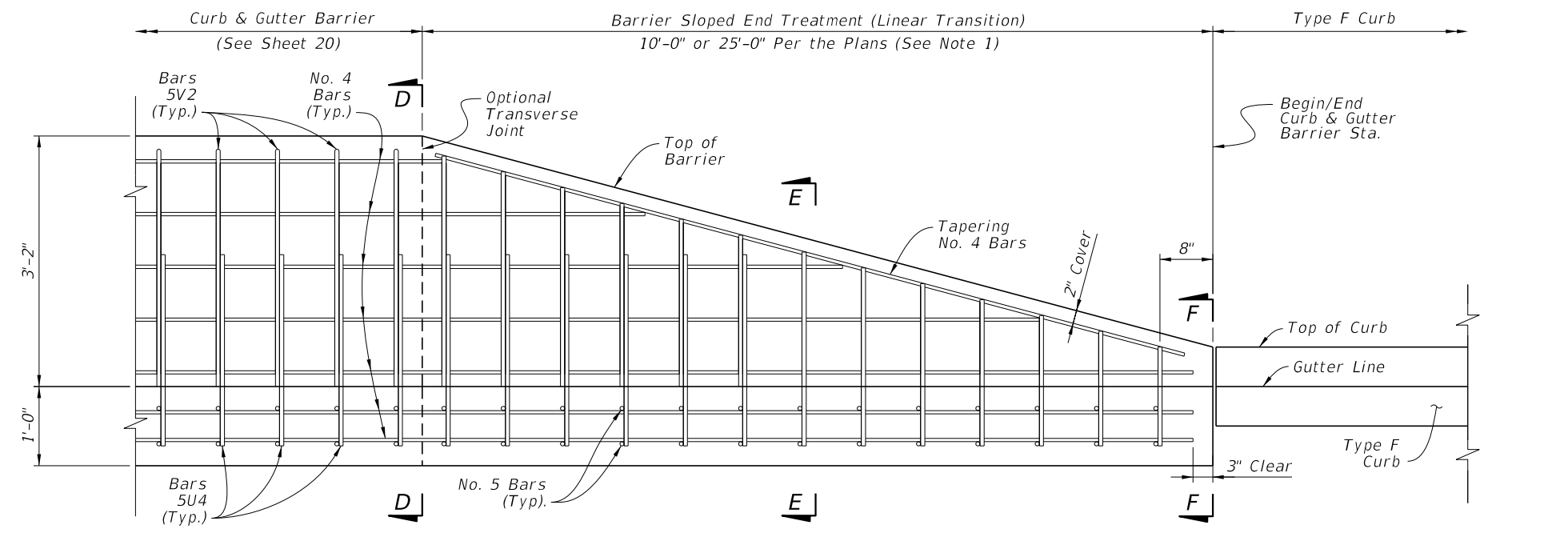

**ELEVATION - CURB AND GUTTER BARRIER
SHOWING SLOPED END TREATMENT
(Approach and Trailing
End Similar by Opposite Hand)**

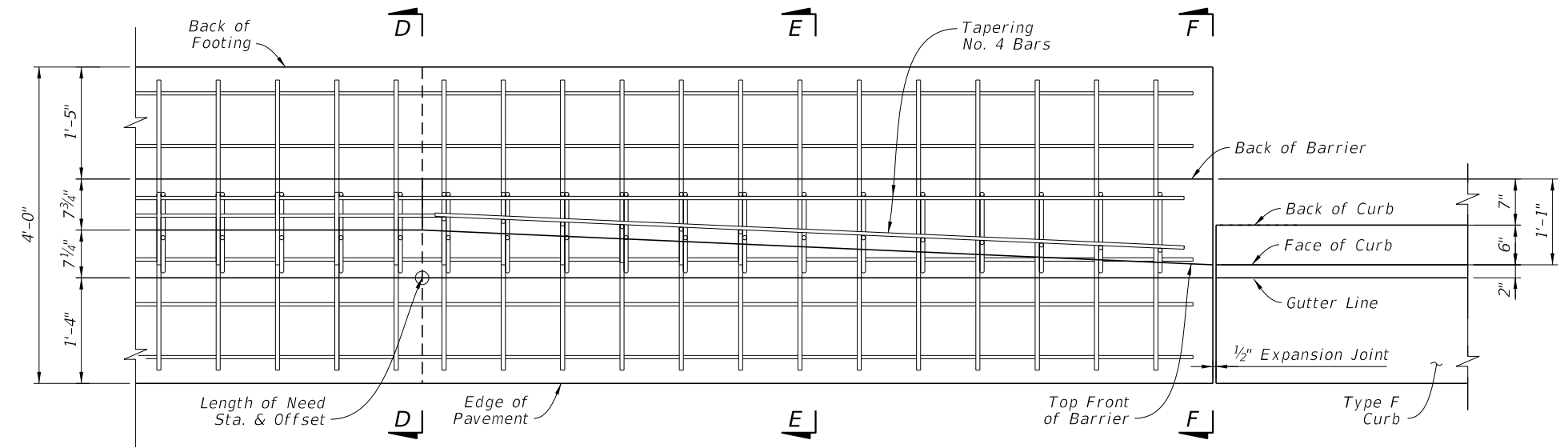

**PLAN - CURB AND GUTTER BARRIER
SHOWING SLOPED END TREATMENT
(Approach and Trailing End
Similar by Opposite Hand;
See Sections for All
Longitudinal Steel Locations)**

NOTES:

1. GENERAL: Install a Sloped End Treatment only where called for in the Plans, using either a 10'-0" length or 25'-0" length treatment as specified in the Plans. The 10'-0" length option is shown herein, while the 25'-0" length option requires additional trimmed Bars 5U4 & 5V2 at the same 9" longitudinal spacing.
2. BAR BENDING DIAGRAMS: For additional details on Bars 5V2 & 5U4, see the Bar Bending Diagrams on Sheet 26.

CURB AND GUTTER BARRIER - SLOPED END TREATMENT

10/20/2022 8:51:03 AM

LAST REVISION 11/01/18	REVISION	DESCRIPTION:	 FY 2023-24 STANDARD PLANS	CONCRETE BARRIER	INDEX 521-001	SHEET 22 of 26
---------------------------	----------	--------------	--	-------------------------	------------------	-------------------

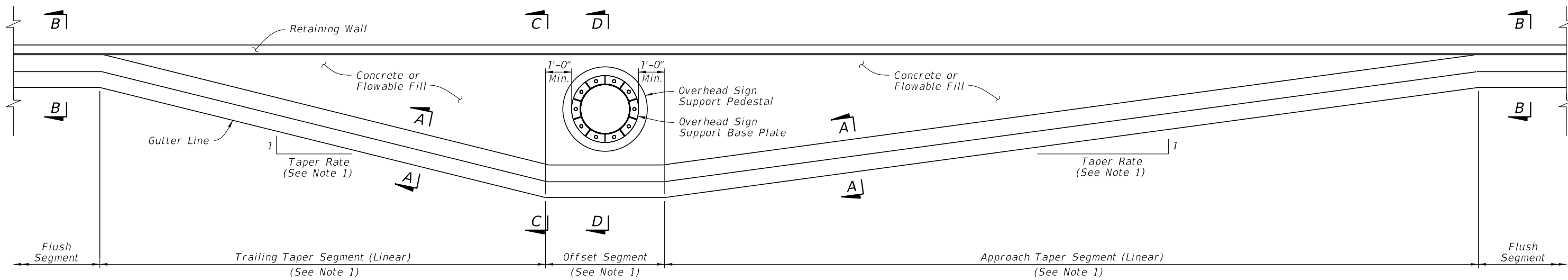

PLAN
(See Section A-A for Barrier Reinforcing)

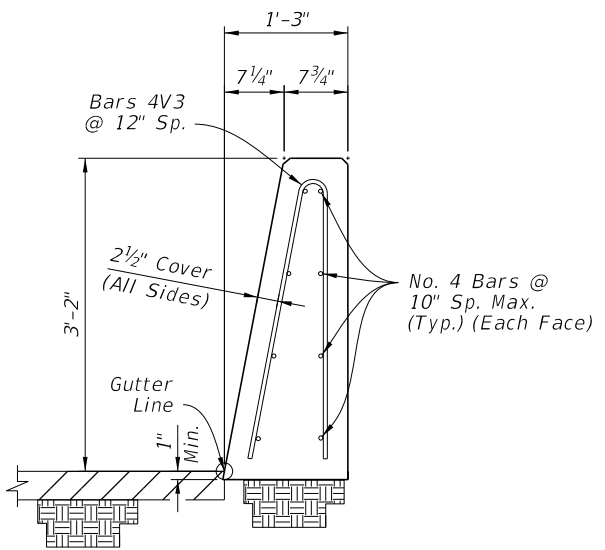

SECTION A-A
38" HEIGHT
SINGLE-FACED SECTION
(Reverse Side Similar by Opposite Hand)

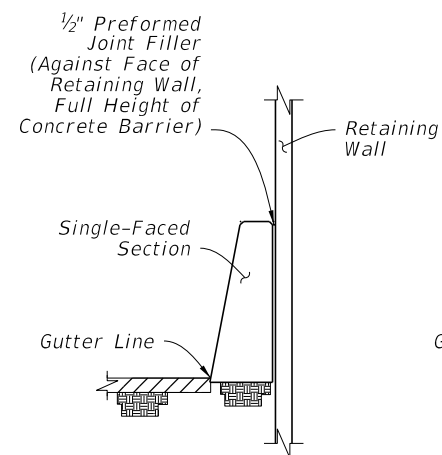

SECTION B-B
FLUSH
SEGMENT

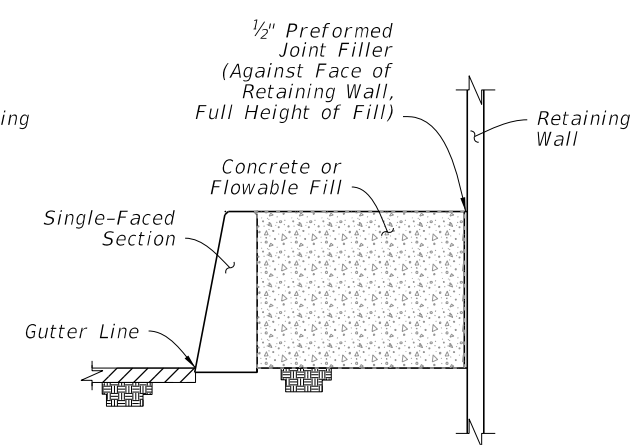

SECTION C-C
OFFSET
SEGMENT

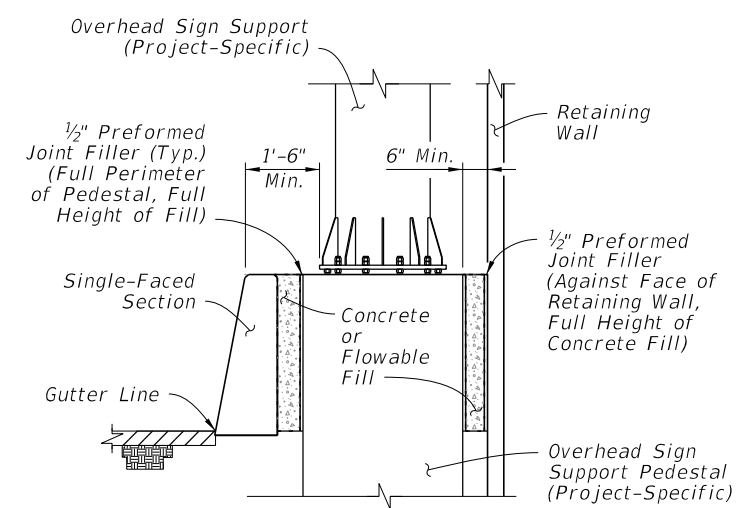

SECTION D-D
OVERHEAD SIGN
SUPPORT

NOTES:

- TAPER SEGMENTS AND OFFSET SEGMENT:** The plan view shown is an example only, showing general geometry for the taper segments and offset segment. For the actual segment lengths and corresponding taper rates required, see the barrier placement information in the Plans.
- OVERHEAD SIGN SUPPORT:** The overhead sign support shown is an example only; see the Plans for the project-specific dimensions and requirements if applicable.
- CONNECTION TO SHOULDER BARRIER SECTIONS:** Connect to Shoulder Barrier sections using a continuous pour or Transverse Joint, where longitudinal steel that aligns within the adjacent section is maintained continuously between sections or has a full lap splice with the adjacent section's longitudinal steel.
- FREE ENDS:** Where shown in the Plans, terminate the Single-Faced Section with a transverse end face. Place a stirrup bar with a 3" cover from the end face. Place longitudinal bars with a 3" cover from the end face.
- CONCRETE OR FLOWABLE FILL:** Use Class NS Concrete in accordance with Specification 347 or Non-Excavatable Flowable Fill in accordance with Specification 121.

WALL SHIELDING BARRIER -
38" HEIGHT SECTION -
APPROACH & TRAILING TRANSITION

10/20/2022 8:51:03 AM

LAST REVISION 11/01/18	REVISION	DESCRIPTION:		FY 2023-24 STANDARD PLANS	CONCRETE BARRIER	INDEX	SHEET
						521-001	23 of 26

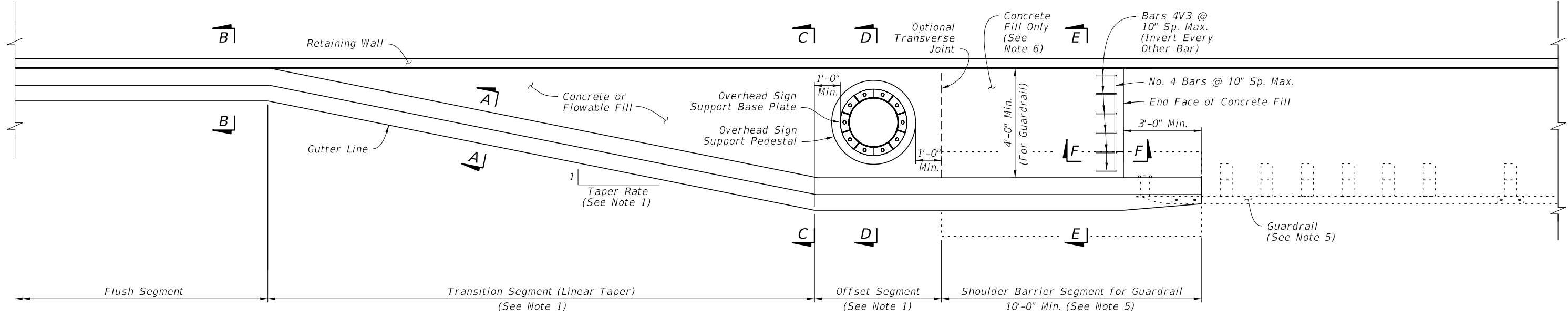

PLAN
(See Section A-A for Barrier Reinforcing)

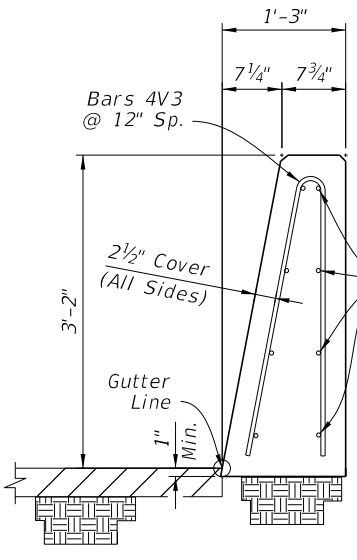

SECTION A-A
38" HEIGHT
SINGLE-FACED SECTION
(Reverse Side Similar by Opposite Hand)

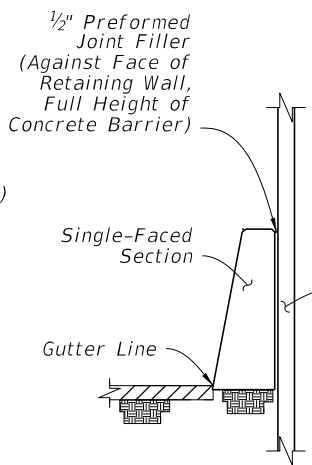

SECTION B-B
FLUSH
SEGMENT

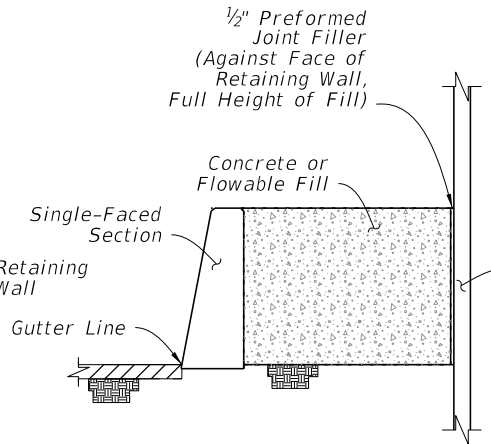

SECTION C-C
OFFSET
SEGMENT

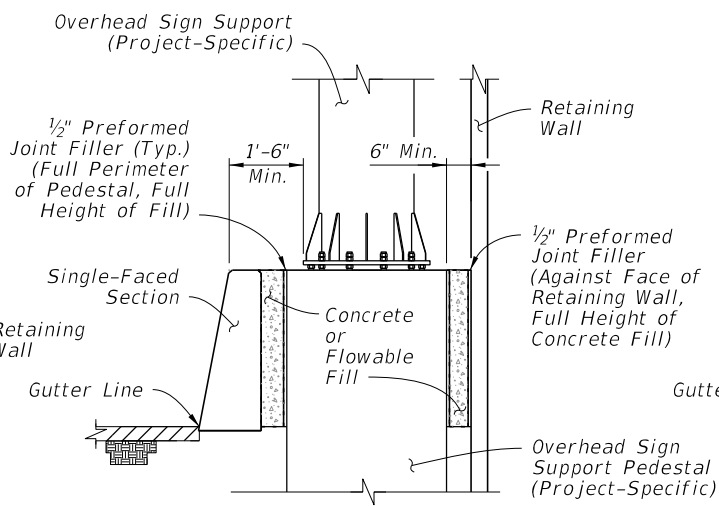

SECTION D-D
OVERHEAD SIGN
SUPPORT

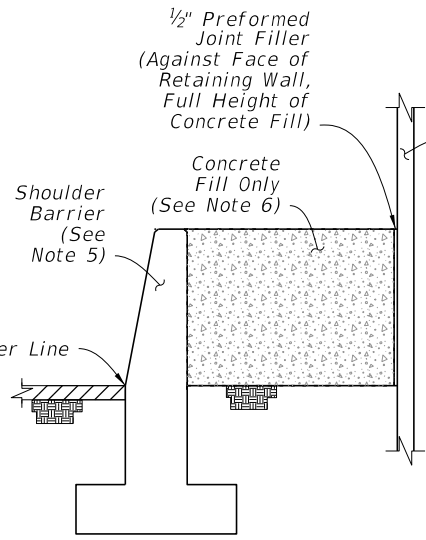

SECTION E-E
SHOULDER BARRIER
SEGMENT FOR
GUARDRAIL

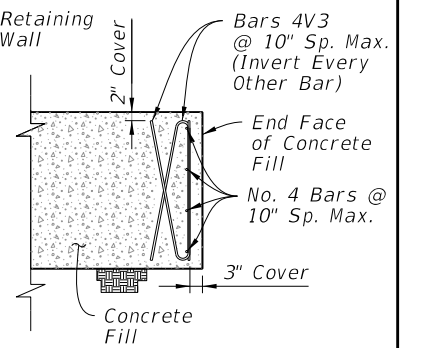

SECTION F-F
CONCRETE FILL
END FACE

NOTES:

- TAPER SEGMENTS AND OFFSET SEGMENT:** The plan view shown is an example only, showing general geometry for the taper segments and offset segment. For the actual segment lengths and corresponding taper rates required, see the barrier placement information in the Plans.
- OVERHEAD SIGN SUPPORT:** The overhead sign support shown is an example only; see the Plans for the project-specific dimensions and requirements if applicable.
- CONNECTIONS TO DIFFERENT CONCRETE BARRIER SECTIONS:** Connect to aligning barrier sections using a continuous pour or Transverse Joint, where longitudinal steel that aligns within the adjacent section is maintained continuously between sections or has a full lap splice with the adjacent section's longitudinal steel.
- FREE ENDS:** Where shown in the Plans, terminate the Single-Faced Section with a transverse end face. Place a stirrup bar with a 3" cover from the end face. Place longitudinal bars with a 3" cover from the end face.
- GUARDRAIL CONNECTIONS:** Within the Shoulder Barrier Segment for Guardrail, install Shoulder Barrier as shown per Sheet 3, including the corresponding End Transition for Guardrail. Connect Guardrail using the Transition Connections to Rigid Barrier per Index 536-001.
- CONCRETE OR FLOWABLE FILL:** Use Class NS Concrete in accordance with Specification 347 or Non-Excavatable Flowable Fill in accordance with Specification 121.
Use only concrete fill behind the Shoulder Barrier Segment; do not use flowable fill at this location.

**WALL SHIELDING BARRIER -
38" HEIGHT SECTION -
GUARDRAIL CONNECTION**

10/20/2022 8:51:04 AM

LAST REVISION 11/01/18	REVISION	DESCRIPTION:		FY 2023-24 STANDARD PLANS	CONCRETE BARRIER	INDEX	SHEET
						521-001	24 of 26

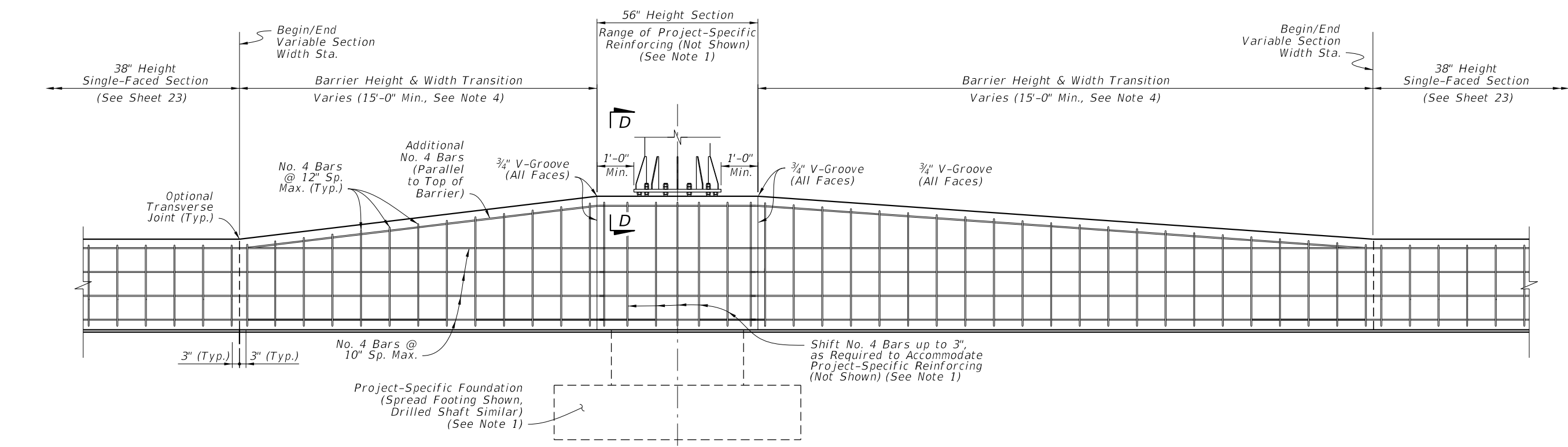

ELEVATION

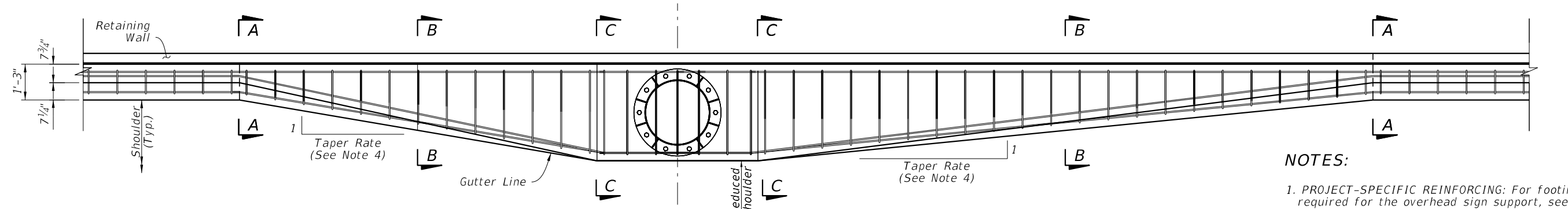

PLAN
(See Note 5)

NOTES:

1. PROJECT-SPECIFIC REINFORCING: For footing and barrier reinforcing required for the overhead sign support, see the project-specific design in the Plans.
2. BARRIER REINFORCING: Maintain the 38" Height Median Barrier's longitudinal steel reinforcing continuously through the barrier height transition and pedestal. Provide the Additional No. 4 Bars and taper as required to maintain a 4 1/2" maximum cover from the top of the barrier.

For the vertical and transverse reinforcement requirements shown in Sections A-A through C-C, bar bending diagrams are not provided due to varying section dimensions. Use any combination of spliced reinforcing steel to position the reinforcement with the same cover, spacing, continuity, and equivalent strength shown herein, as approved by the Engineer.
3. PROJECT-SPECIFIC PEDESTAL WIDTH & SETBACK: The pedestal width is governed by the size requirements of the overhead sign support, as detailed in the Plans. Likewise, the setback distance from the sign support base to the barrier face is governed by the anchor bolt cover requirements, as defined per the Plans.
4. TRANSITION SEGMENTS: The Transition Segments shown are examples only. For the actual approach and trailing transition taper rate, length, and width, see the details in the Plans.
5. PLAN VIEW: Only top and bottom longitudinal reinforcing is shown for clarity. For all longitudinal reinforcing locations, see the Section Views.

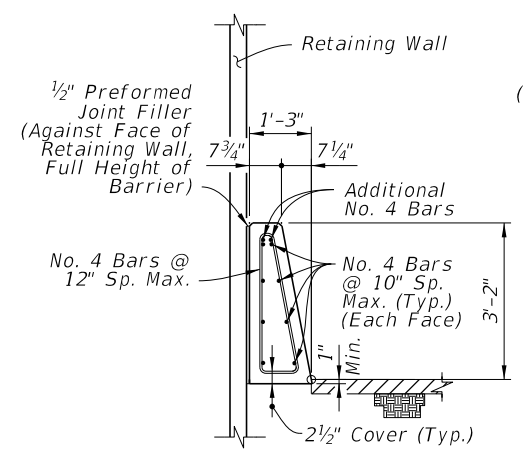

SECTION A-A
BEGIN TRANSITION

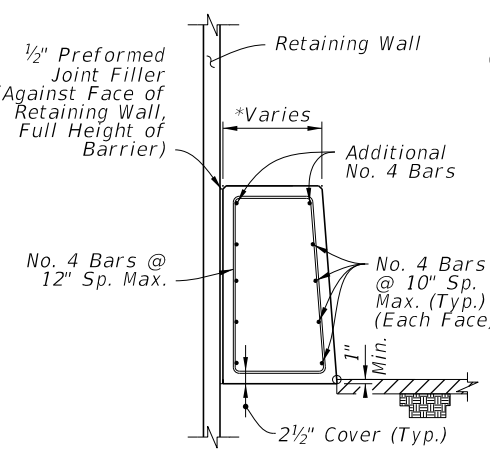

SECTION B-B
*Dimension Varies Linearly Between Section A-A and C-C

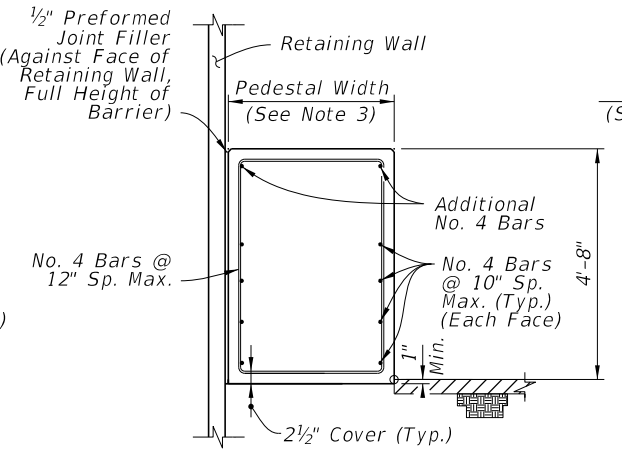

SECTION C-C
END TRANSITION
(56" Height Section)

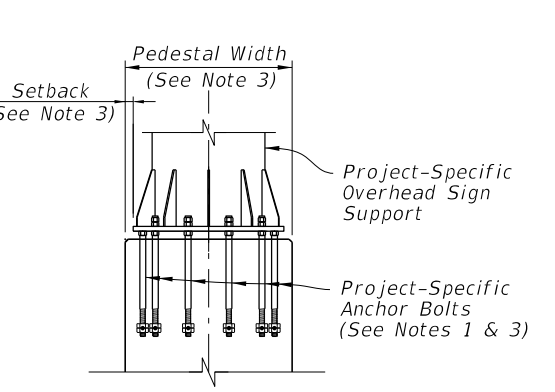

SECTION D-D
(Reinforcing Steel Not Shown for Clarity)

WALL SHIELDING BARRIER - 56" HEIGHT
SECTION FOR BARRIER-MOUNTED
SIGN SUPPORT SHIELDING

12/7/2022 10:37:19 AM

LAST REVISION 11/01/18	DESCRIPTION:		FY 2023-24 STANDARD PLANS	CONCRETE BARRIER	INDEX 521-001	SHEET 25 of 26
REVISION						

BILL OF REINFORCING STEEL		
MARK	SIZE	LENGTH
C1	4	3'-8"
C2	5	3'-0"
U1	4	5'-1"
U2	4	7'-8"
U3	5	9'-7"
U4	5	5'-9"
V1	4	6'-4"
V2	5	6'-3"
V3	4	5'-10"

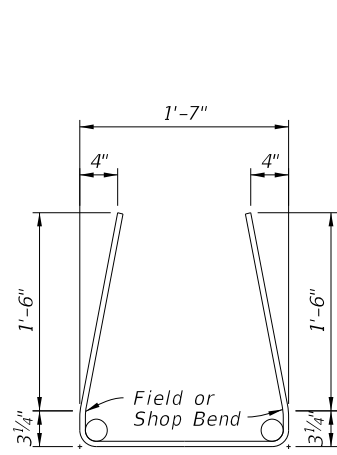

BARS 4U1

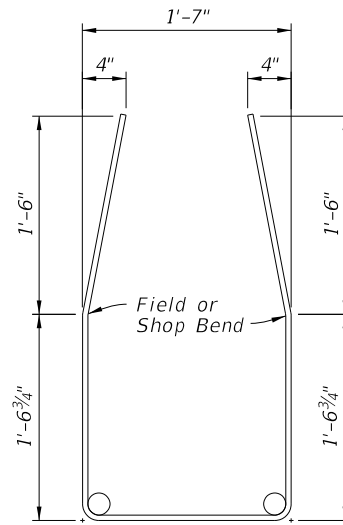

BAR 4U2

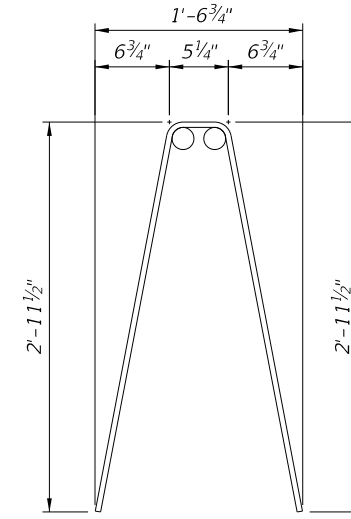

BAR 4V1

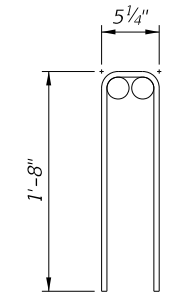

BAR 4C1

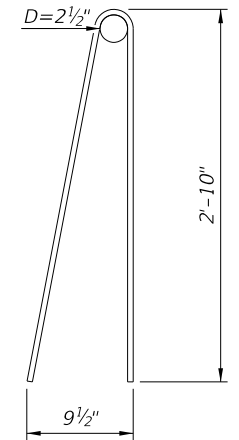

BAR 4V3

NOTES:

1. Work with the Standard Bar Bending Details per Index 415-001.
2. All bar dimensions in the bending diagrams are out to out.
3. Use standard inner diameters for bar bending unless otherwise shown.

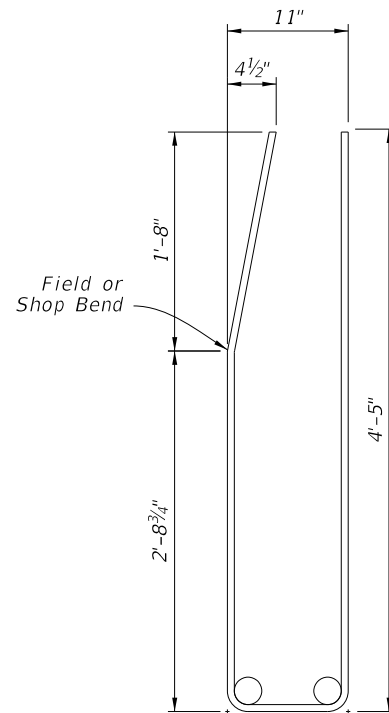

BAR 5U3

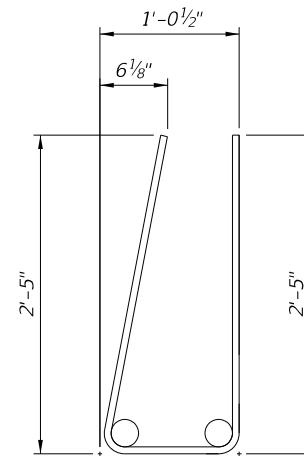

BAR 5U4

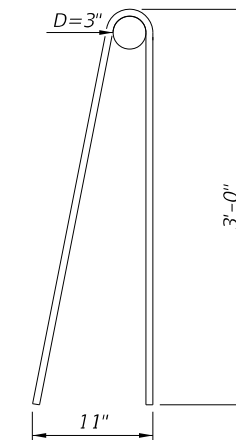

BAR 5V2

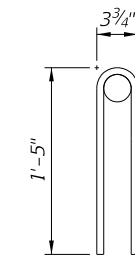

BAR 5C2

10/20/2022 8:51:06 AM

REINFORCING BAR BENDING DIAGRAMS

LAST REVISION 11/01/18	DESCRIPTION:	 FY 2023-24 STANDARD PLANS	CONCRETE BARRIER	INDEX 521-001	SHEET 26 of 26
---------------------------	--------------	--	------------------	------------------	-------------------

SHEET NO.	CONTENTS
1	Index Contents; General Notes
2	Example Layouts - Footing Placement and Connections
3	Barrier Plan and Elevation - Connection to Concrete Barrier - Connection to Guardrail
4	Barrier Details - Connection to Concrete Barrier
5	Barrier Details - Connection to Guardrail
6	Barrier Footing Options
7	Crash Wall Details
8	Reinforcing Bar Bending Diagrams

GENERAL NOTES:

1. **CONCRETE:** Use Class III or IV concrete unless otherwise called for in the Plans.
2. **CONSTRUCTION JOINTS:** Maintain continuity of reinforcement steel across Construction Joints; reinforcement lap splices are permitted immediately adjacent to joints. Construct all Pier Protection Barrier continuously, with no expansion or contraction joints. Construction Joints are classified herein as Transverse Joints or Longitudinal Joints.

 Transverse Joints are permitted at 40 foot or greater intervals along the barrier.

 Longitudinal Joints may only be installed where indicated in the following details and notes, with a location tolerance of $\pm 1"$ from the locations shown.
3. **FOUNDATION:** Compact the top 12 inches of the subgrade to at least 98% of the maximum density determined by FM 1-T 180, Method D.
4. **DRAINAGE INLETS:** See Index 425-031 for Adjacent Barrier Inlets, and isolate these structures from Pier Protection Barriers and Footings with 1" Preformed Joint Filler.
5. **BARRIER END MARKERS:** For all free ends of barriers that are not connected to guardrail or concrete barrier, install a Type 3 Object Marker on the end face per Specification 705.
6. **BARRIER DELINEATORS:** Install Barrier Delineators in accordance with Specification 705. Mount the delineators on the top face of the barrier, with the roadway side of the delineator located 2" from the front face of the barrier and the reflective sheeting facing traffic of the nearest approach.
7. **CRACK CONTROL:** Provide $\frac{1}{2}"$ depth crack control V-Grooves at 15' to 30' spacing. Locate V-Grooves above any joint or discontinuity in the barrier footing. Align V-Grooves perpendicular to the longitudinal axis of the Pier Protection Barrier and make continuous across the top surface and both side faces. For slip formed barriers, score $\frac{1}{2}"$ V-Grooves while the concrete is still plastic, otherwise pre-form the joints when stationary forms are utilized.

10/20/2022 8:51:07 AM

LAST REVISION 11/01/18	REVISION DESCRIPTION:	 FY 2023-24 STANDARD PLANS	PIER PROTECTION BARRIER	INDEX 521-002	SHEET 1 of 8
------------------------------	--------------------------	---	--------------------------------	-------------------------	------------------------

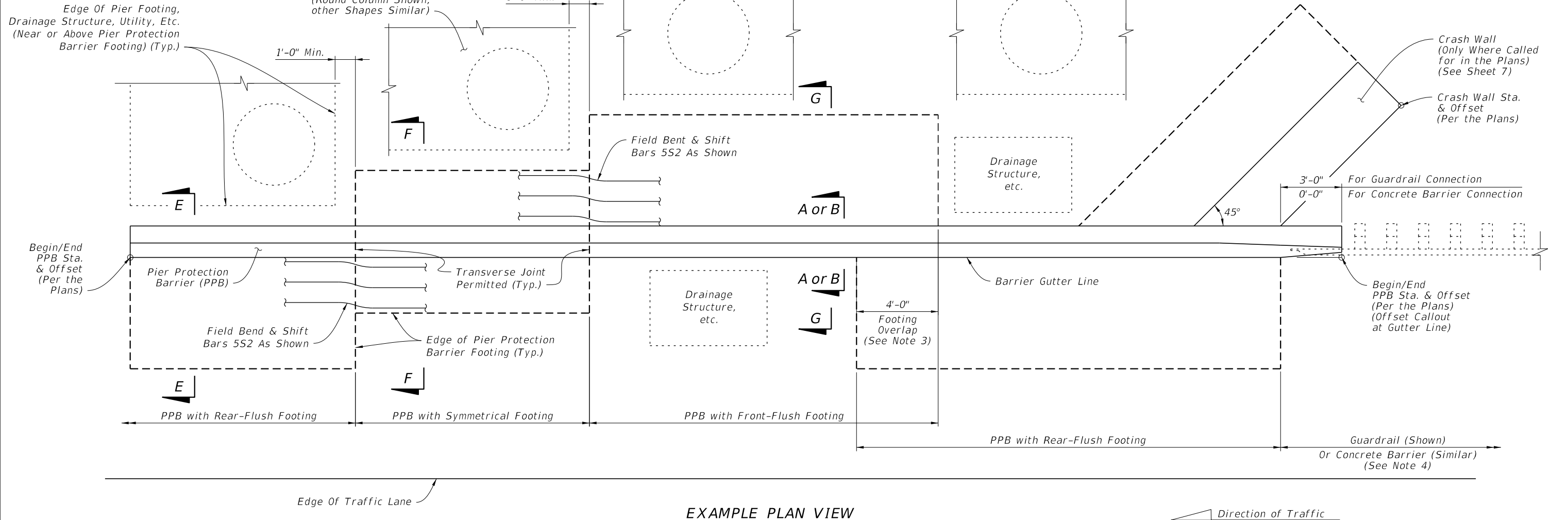

EXAMPLE PLAN VIEW

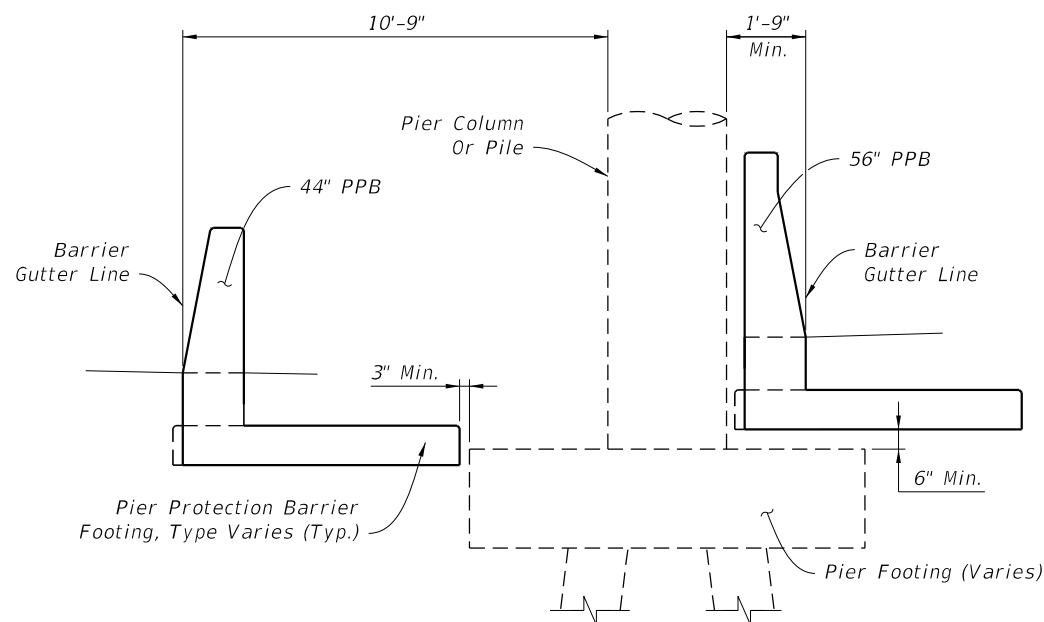

EXAMPLE SECTION VIEW

NOTES:

1. GENERAL: The views shown herein are schematic only, showing example layouts for Pier Protection Barrier (PPB) footings and Crash Wall placement in relation to adjacent miscellaneous structures (including bridge piers, footings, drainage structures, etc.). The actual PPB footing placement depends on the project-specific configuration of adjacent structures and obstacles. For project-specific locations of PPB and adjacent features, see the Plans.
2. MINIMUM FOOTING LENGTH: The minimum length of a single footing option (i.e. Symmetrical Footing, Rear-Flush Footing, Front-Flush Footing), is 8'-0", measured longitudinally. See Sheet 6 for the footing option details.
3. FOOTING OVERLAP: When a Front-Flush Footing section connects to a Rear-Flush Footing section, a 4'-0" footing overlap is required as shown. In footing overlap segments, place all lateral steel reinforcement continuously for the entire width of the combined footing while maintaining the cover requirements per Sheet 6.
4. CONNECTING GUARDRAIL OR CONCRETE BARRIER: Connect the PPB to either Guardrail or Concrete Barrier as specified in the Plans. For additional Guardrail Details, see Sheet 3 and Index 536-001. For additional Concrete Barrier Details, see Sheet 3 and Index 521-001.

EXAMPLE LAYOUTS - FOOTING PLACEMENT AND CONNECTIONS

10/20/2022 8:51:08 AM

LAST REVISION 11/01/17	REVISION	DESCRIPTION:		FY 2023-24 STANDARD PLANS	PIER PROTECTION BARRIER	INDEX 521-002	SHEET 2 of 8
---------------------------	----------	--------------	---	------------------------------	-------------------------	------------------	-----------------

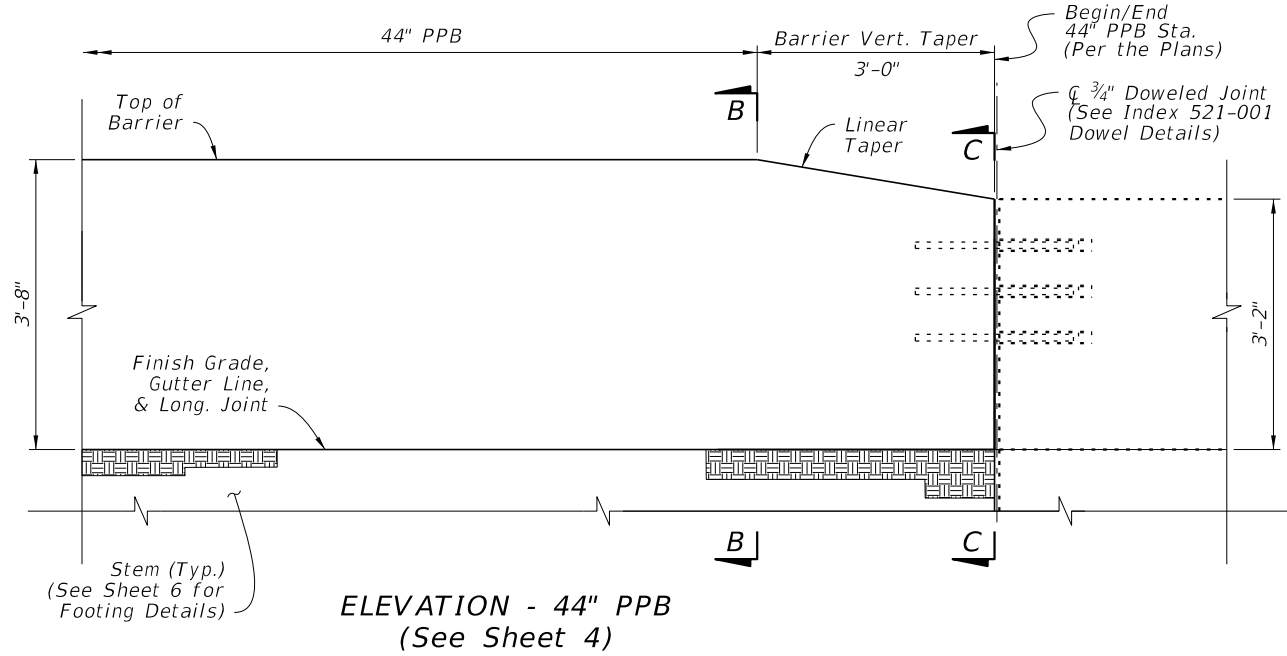

ELEVATION - 44" PPB
(See Sheet 4)

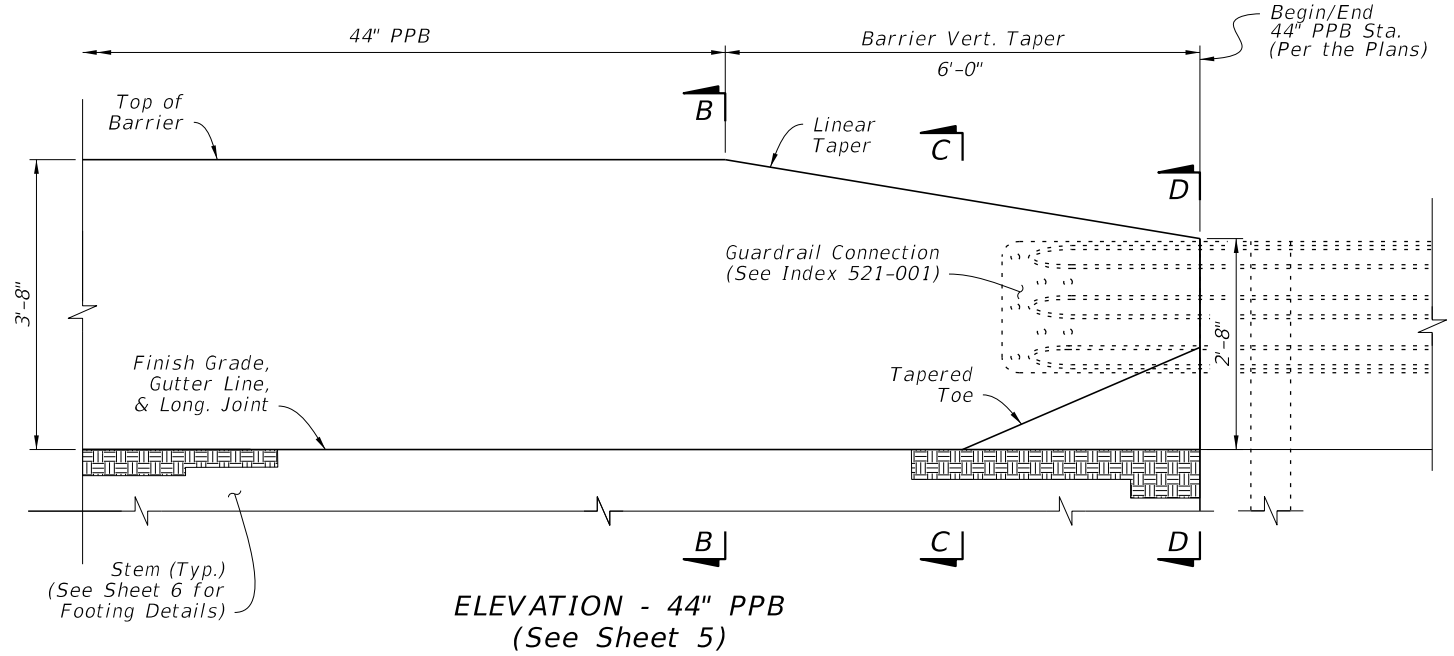

ELEVATION - 44" PPB
(See Sheet 5)

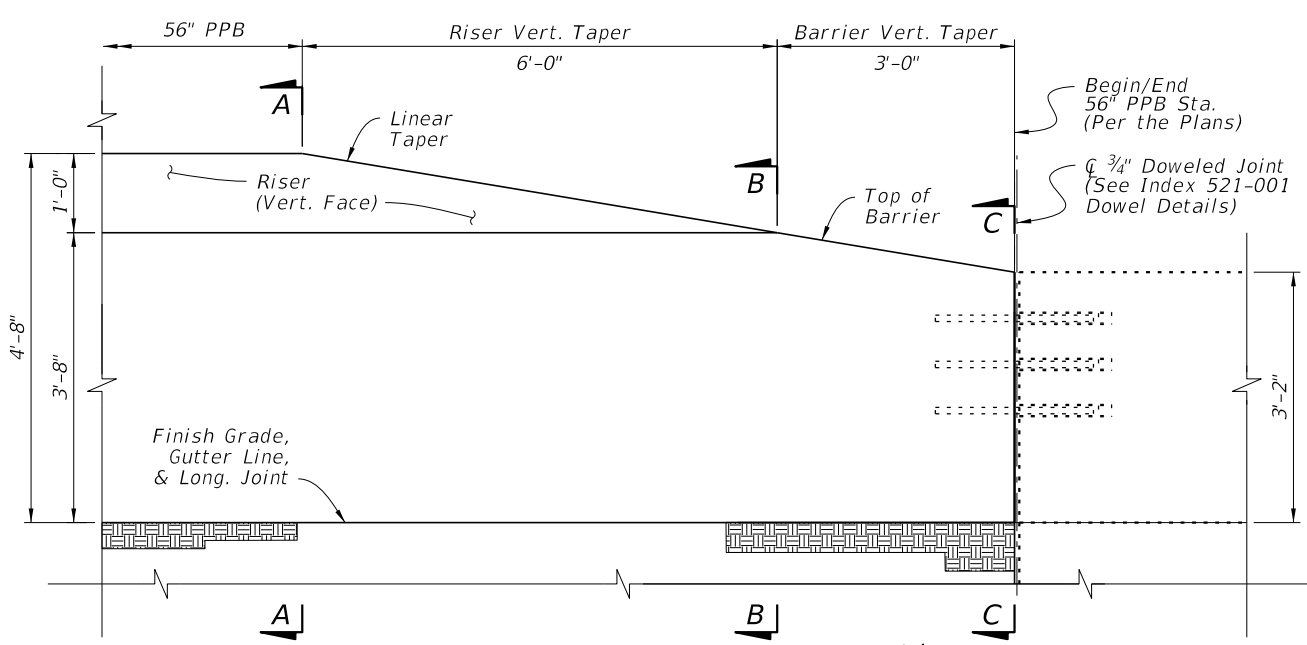

ELEVATION - 56" PPB
(See Sheet 4)

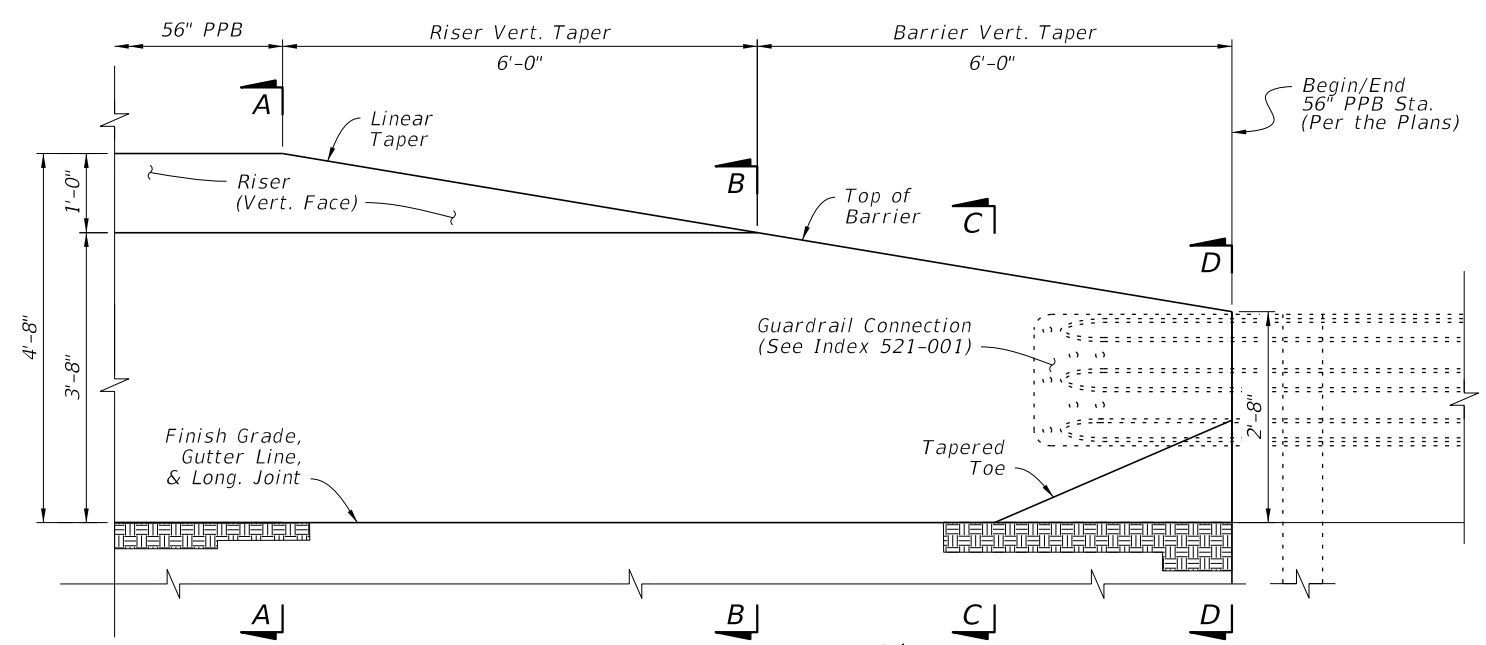

ELEVATION - 56" PPB
(See Sheet 5)

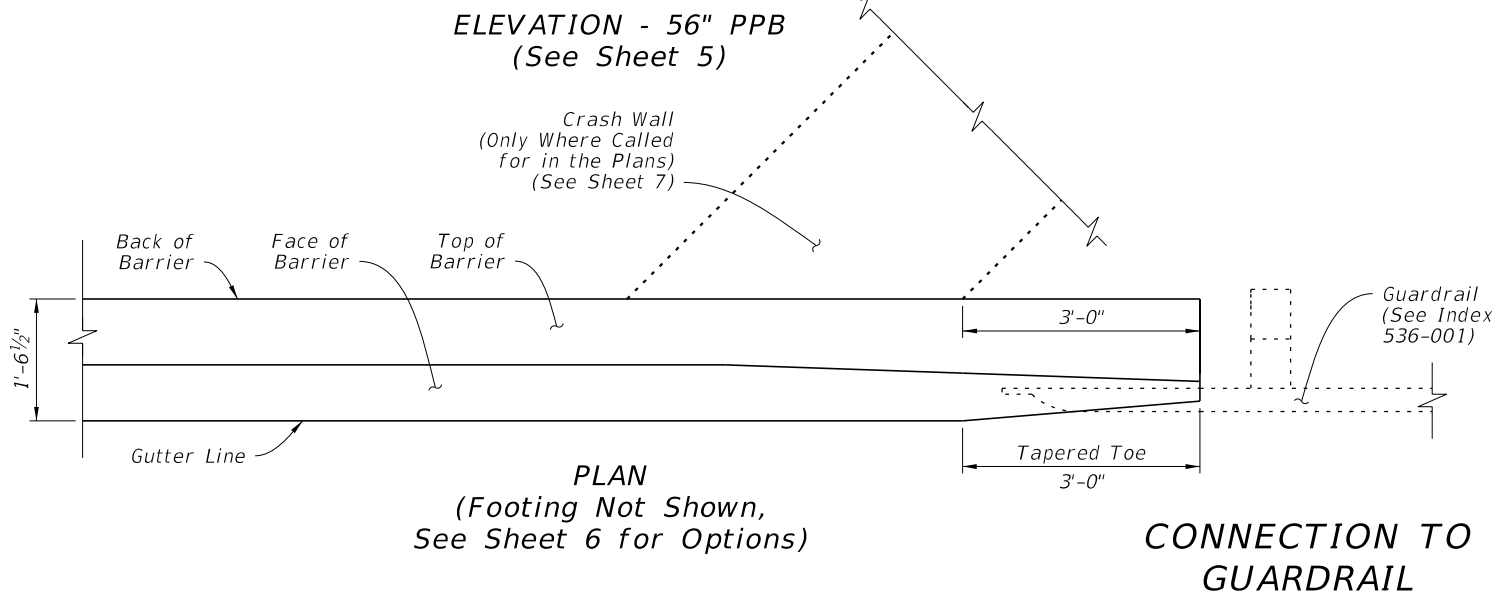
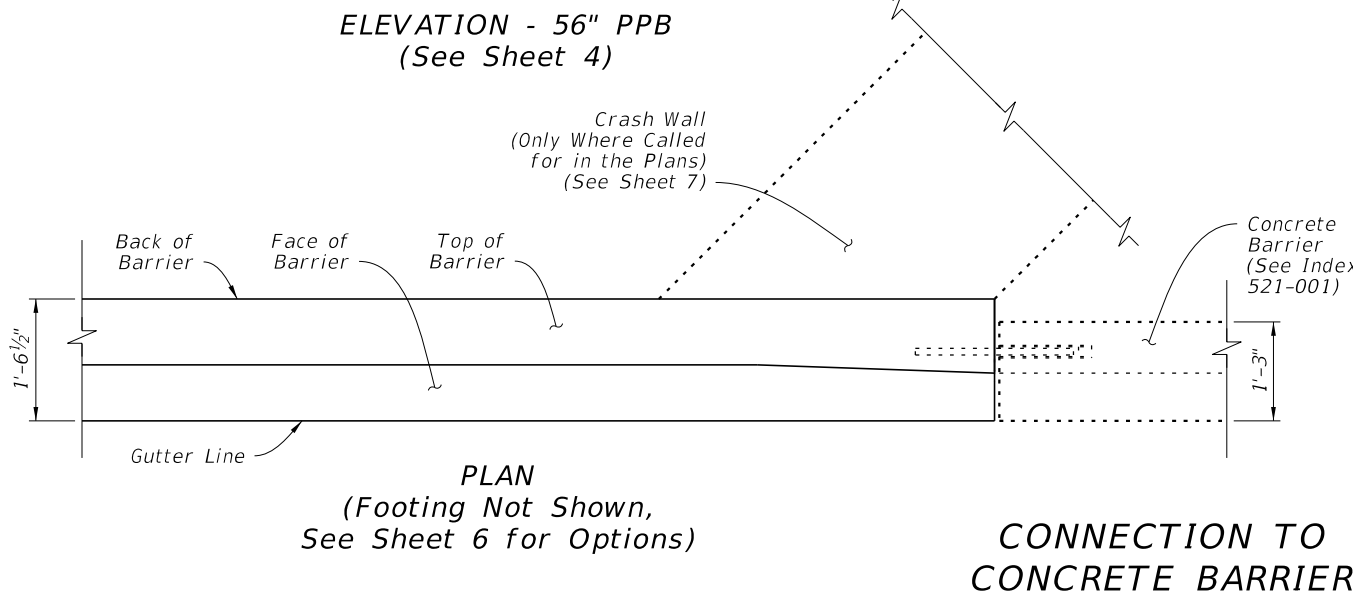

10/20/2022 8:51:09 AM

LAST REVISION 11/01/17	DESCRIPTION:
---------------------------	--------------

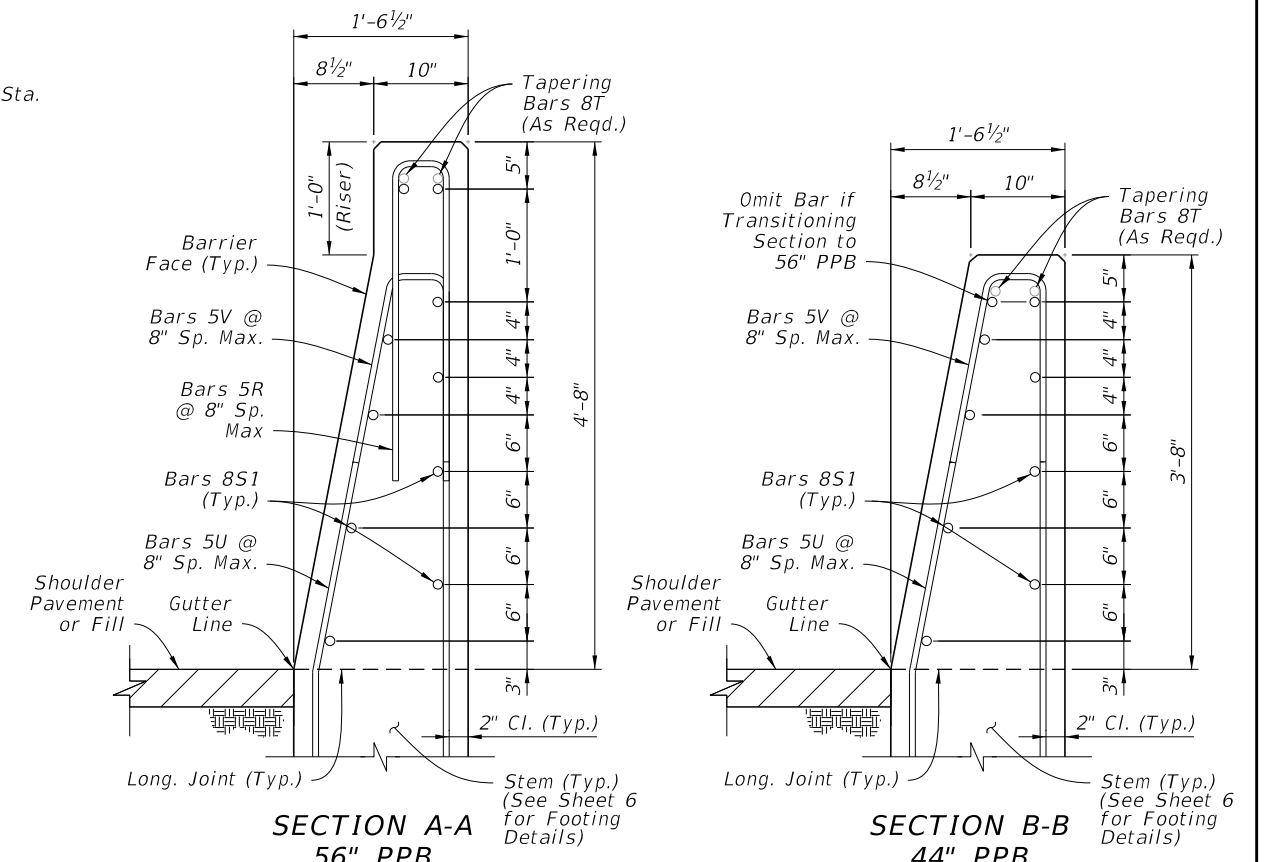
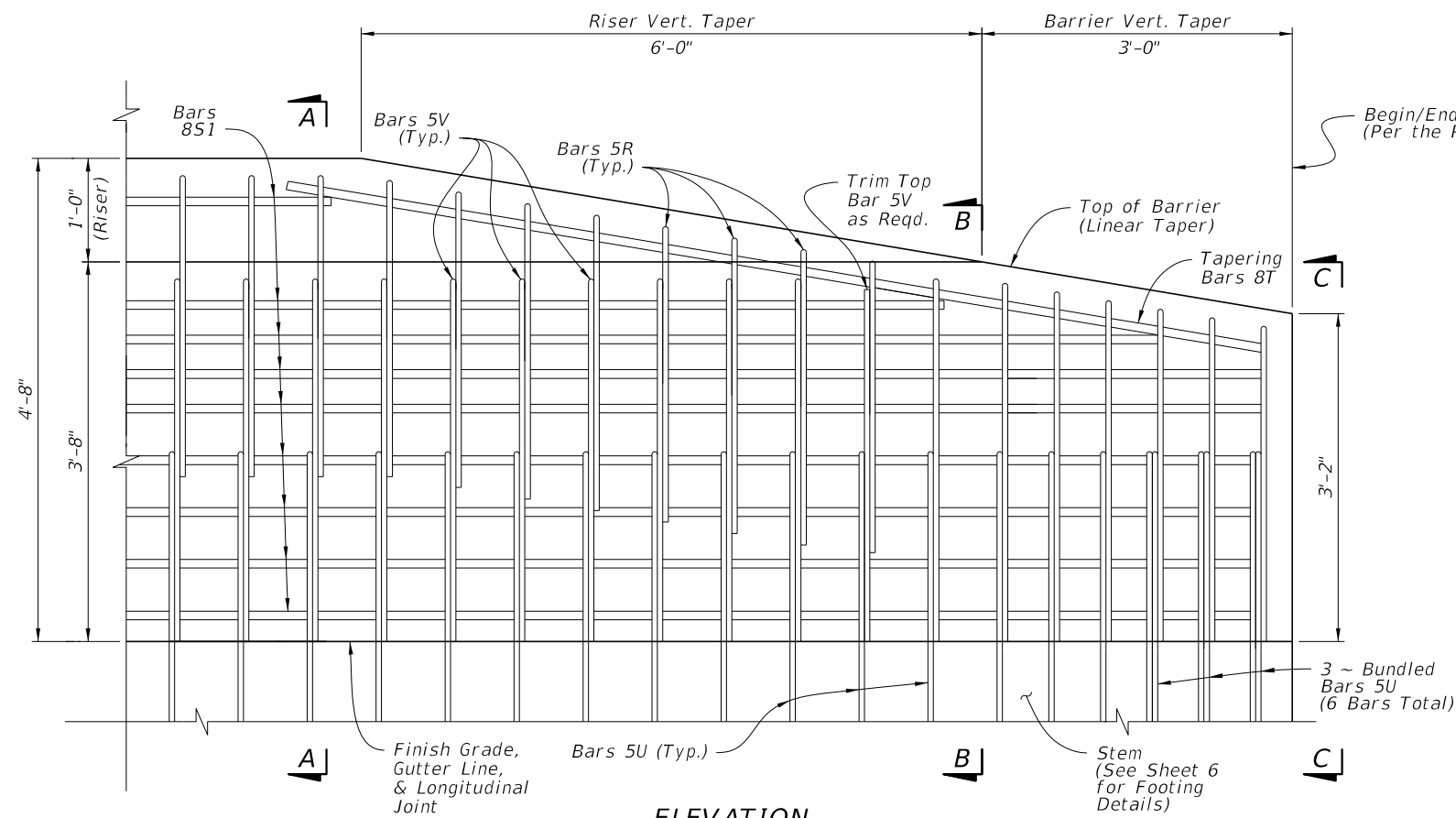

Concrete Qty. = 0.19 CY/FT (Above Gutter Line)
Steel Qty. = 47.7 LB/FT (Excluding Bars 5U & 8T)

Concrete Qty. = 0.16 CY/FT (Above Gutter Line)
Steel Qty. = 35.7 LB/FT (Excluding Bars 5U & 8T)

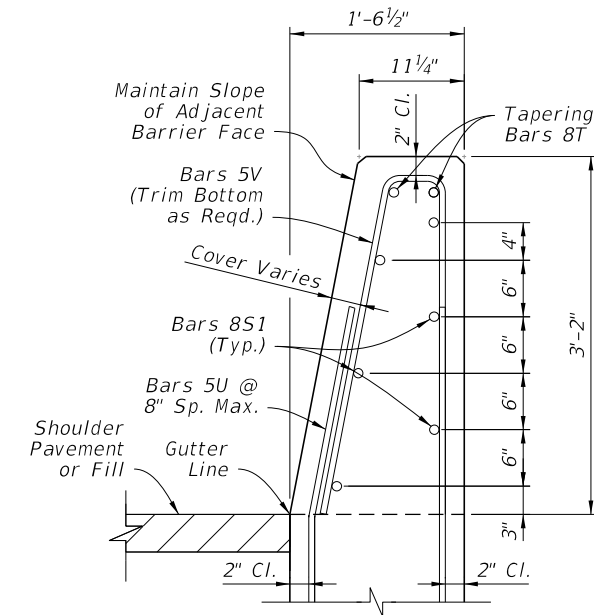
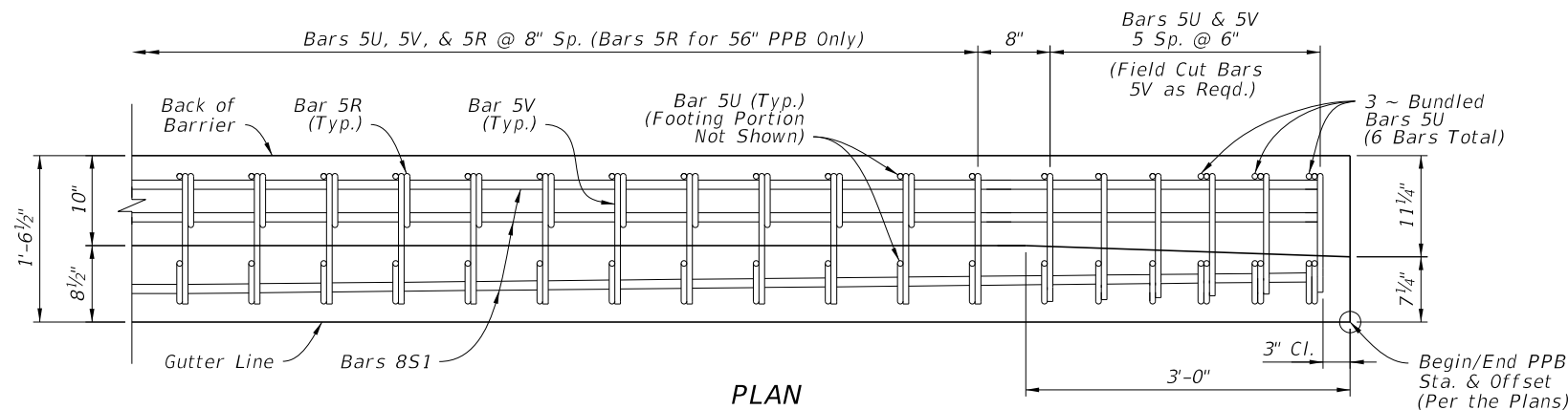

NOTES:

- GENERAL: Construct either the 56" PPB or the 44" PPB height as called for in the Plans. See Sheets 2 & 3 for additional plan and elevation details.
- FOOTING OPTIONS: See Sheet 6 for the supporting stem and footing details.

BARRIER DETAILS - CONNECTION TO CONCRETE BARRIER

10/20/2022 8:51:09 AM

LAST REVISION 11/01/17	DESCRIPTION:		FY 2023-24 STANDARD PLANS	PIER PROTECTION BARRIER	INDEX	SHEET
			521-002		4 of 8	

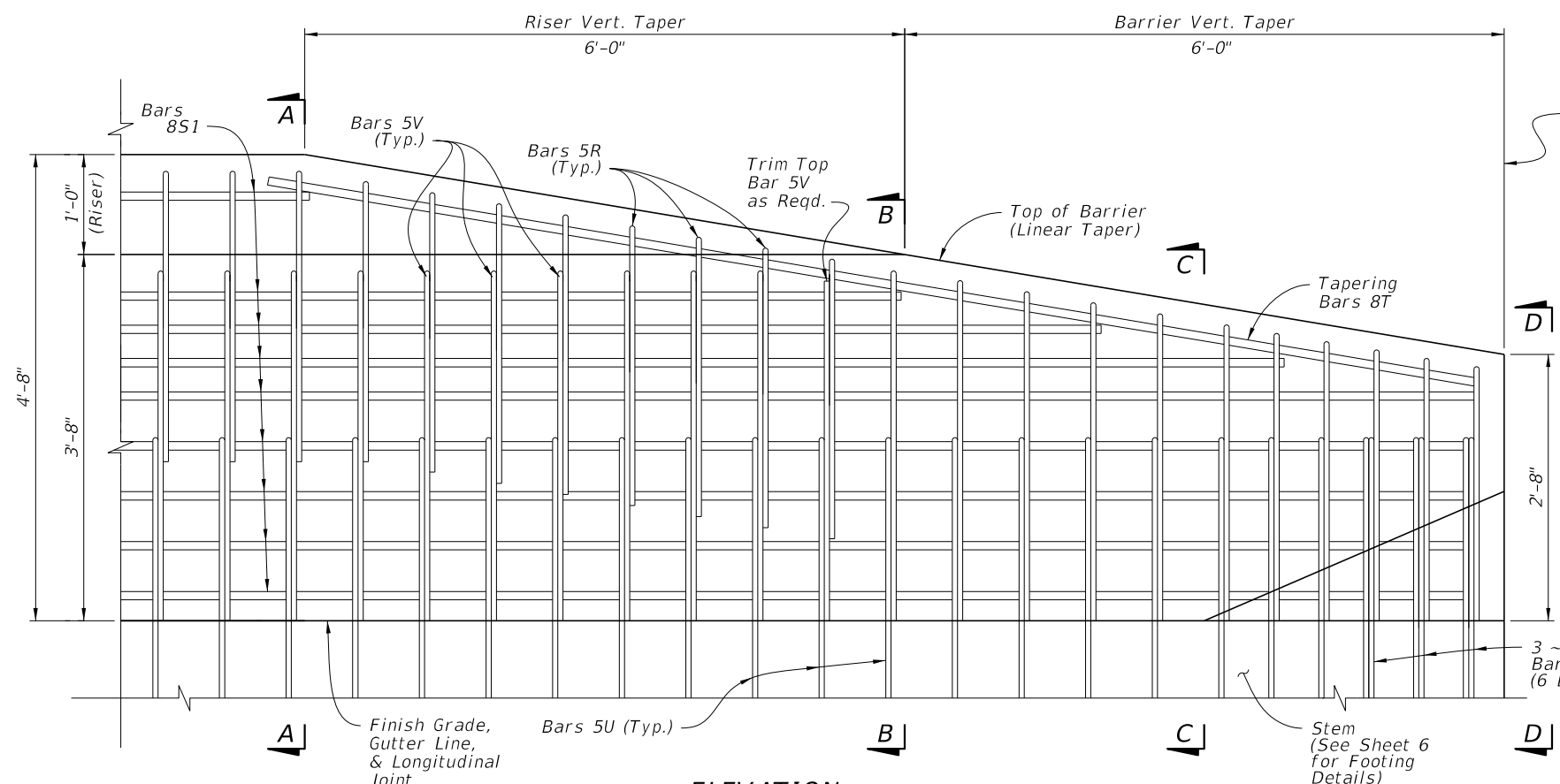

ELEVATION
 (56" PPB Shown, 44" PPB Similar with 1'-0" Riser and Related Reinforcing Removed)

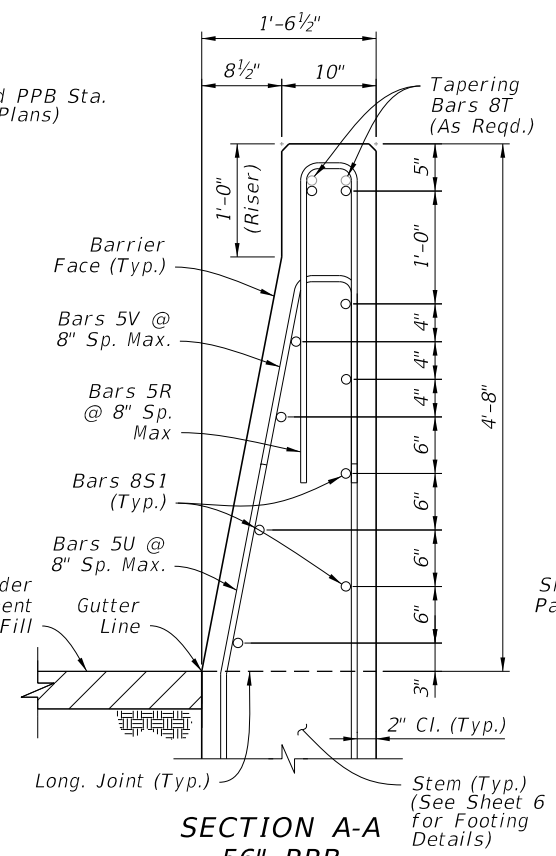

SECTION A-A
 56" PPB

Concrete Qty. = 0.19 CY/FT (Above Gutter Line)
 Steel Qty. = 47.7 LB/FT (Excluding Bars 5U & 8T)

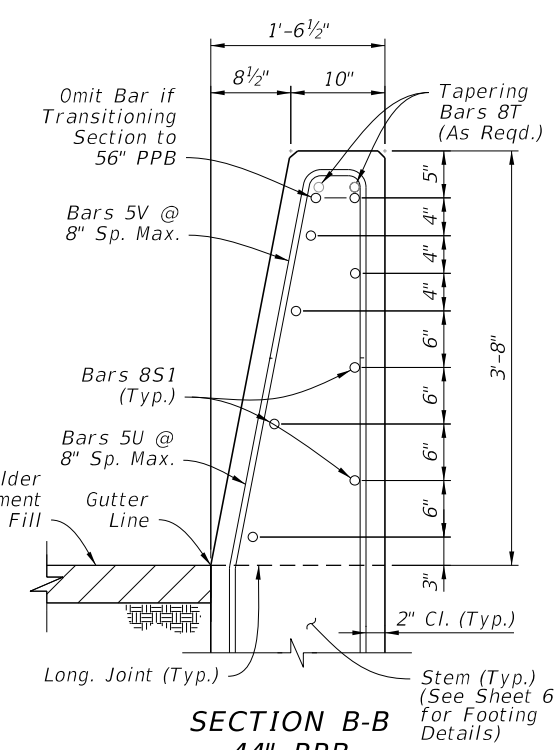

SECTION B-B
 44" PPB

Concrete Qty. = 0.16 CY/FT (Above Gutter Line)
 Steel Qty. = 35.7 LB/FT (Excluding Bars 5U & 8T)

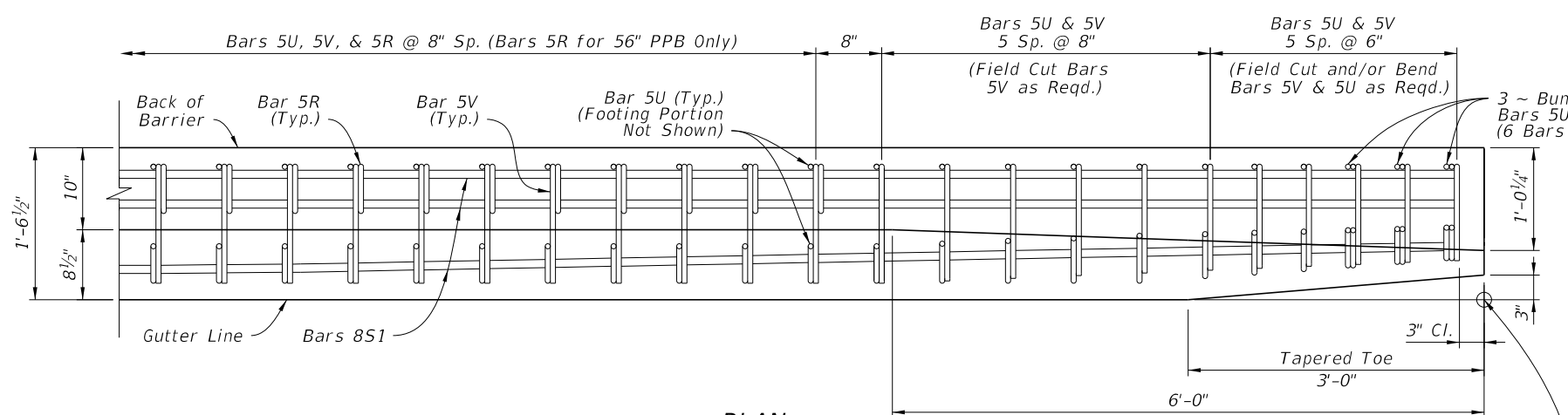

PLAN
 (Details Not Shown Below Gutter Line, See Sheet 6 for Footing and Stem Details)
 (Only Top & Bottom Longitudinal Steel Shown, See Section Views for All Steel Locations)

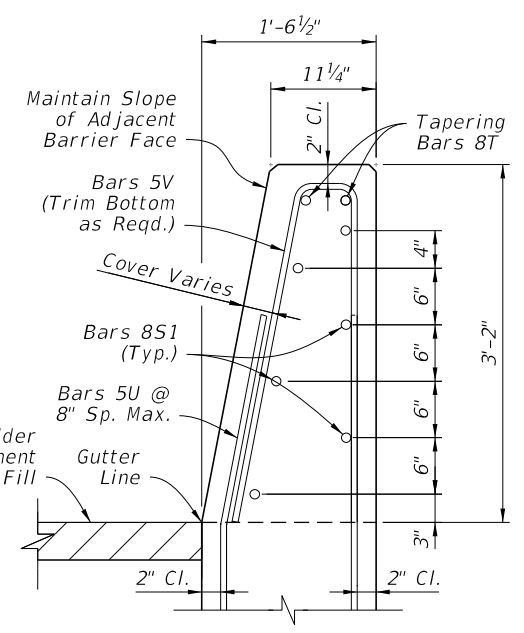

END VIEW C-C
 (Begin Tapered Toe for Guardrail)

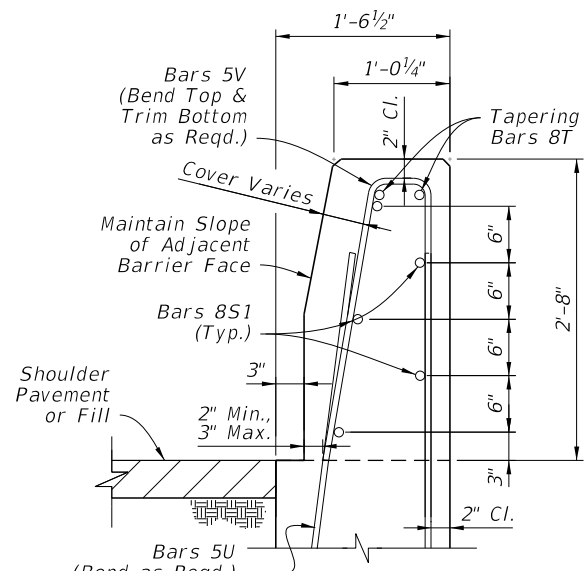

END VIEW D-D
 (End Tapered Toe for Guardrail)

NOTES:

- GENERAL: Construct either the 56" PPB or the 44" PPB height as called for in the Plans. See Sheets 2 & 3 for additional plan and elevation details.
- FOOTING OPTIONS: See Sheet 6 for the supporting stem and footing details.

BARRIER DETAILS - CONNECTION TO GUARDRAIL

10/20/2022 8:51:10 AM

LAST REVISION 11/01/17	DESCRIPTION:		FY 2023-24 STANDARD PLANS	PIER PROTECTION BARRIER	INDEX	SHEET
					521-002	5 of 8

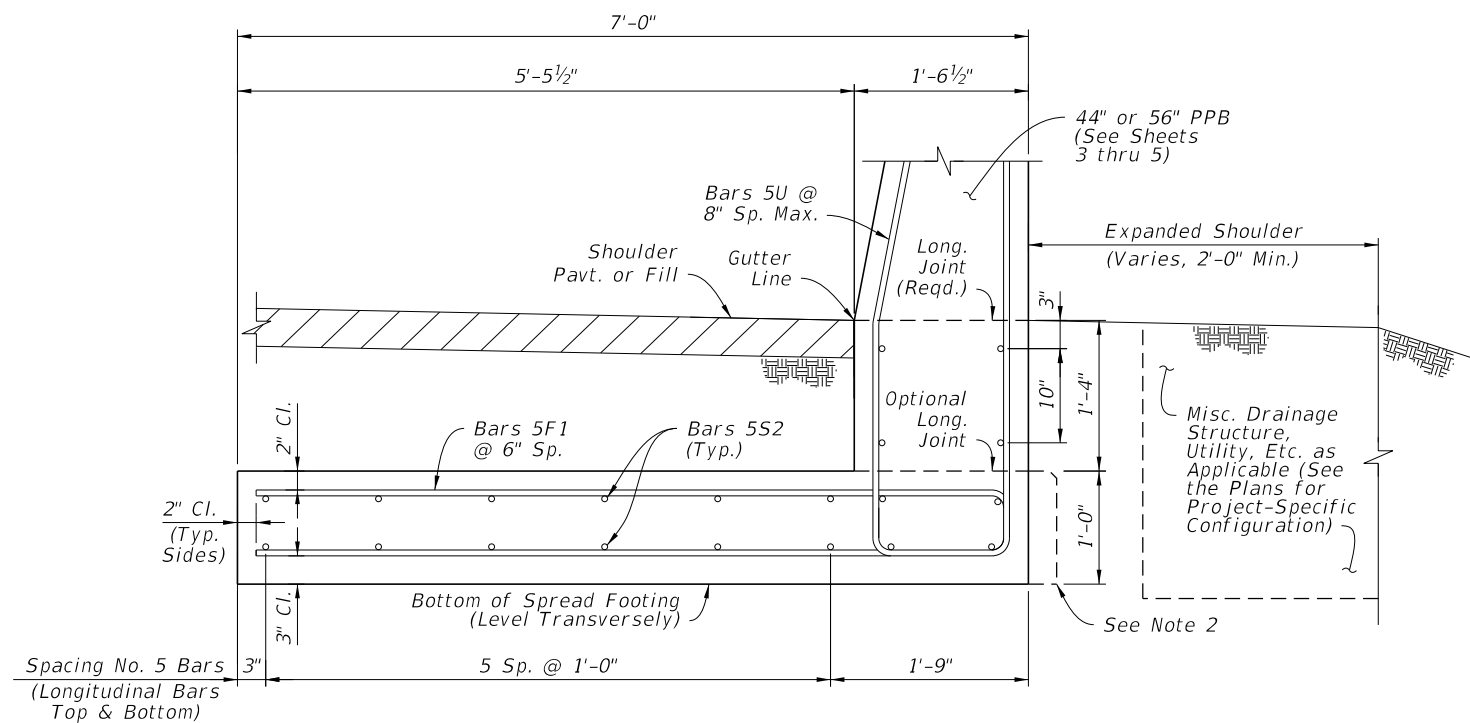

**SECTION E-E
REAR-FLUSH FOOTING OPTION**

Concrete Qty. = 0.34 CY/FT (Below Gutter Line)
Steel Qty. = 63.5 LB/FT (Including Bars 5U)

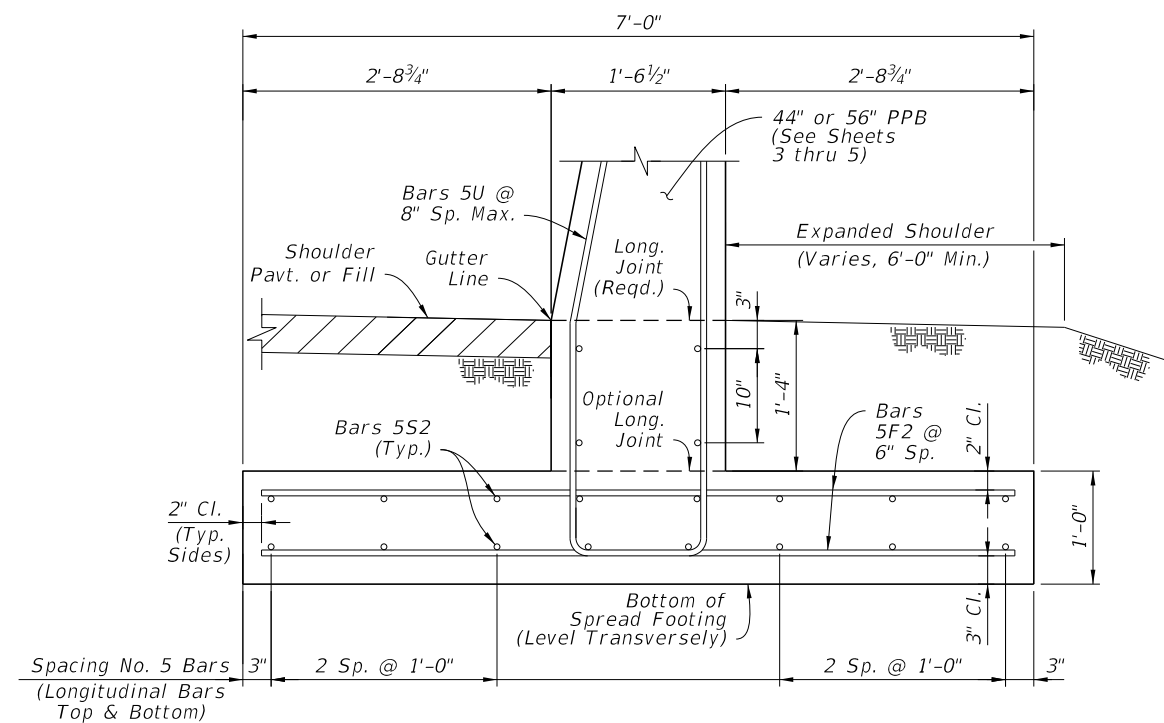

**SECTION F-F
SYMMETRICAL FOOTING OPTION**

Concrete Qty. = 0.34 CY/FT (Below Gutter Line)
Steel Qty. = 62.6 LB/FT (Including Bars 5U)

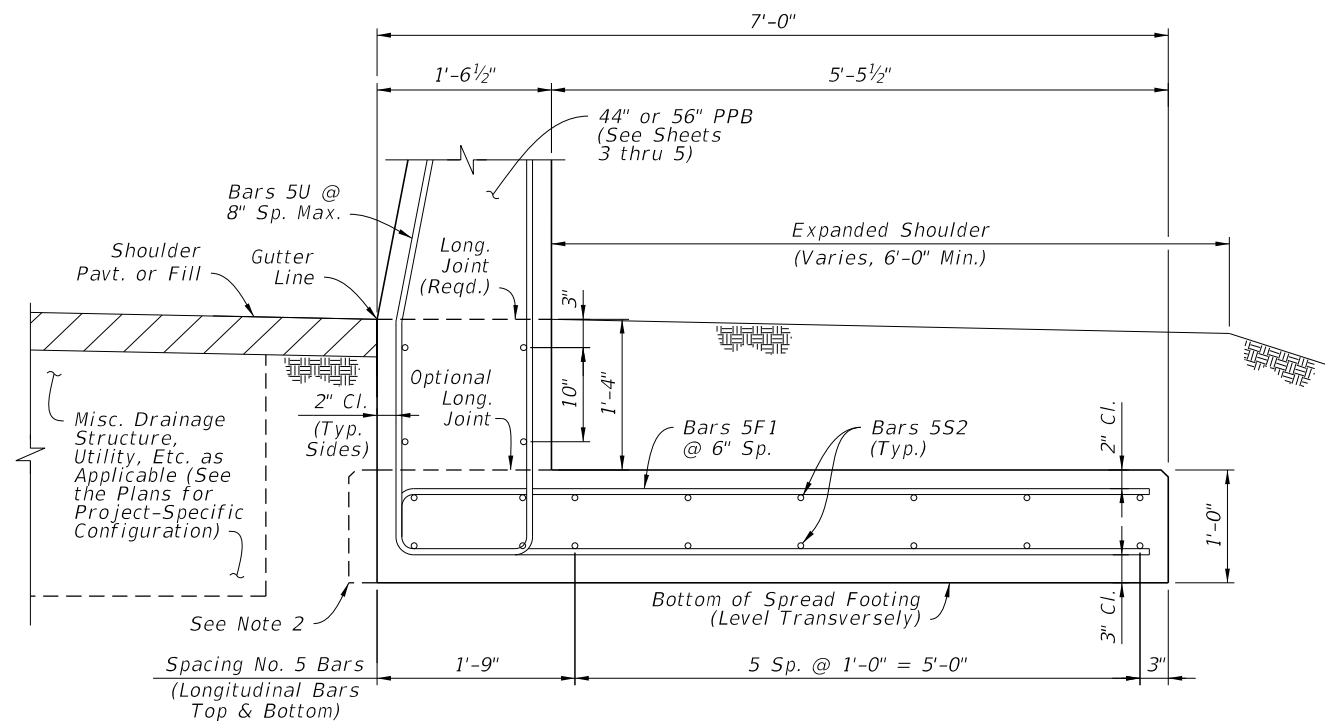

**SECTION G-G
FRONT-FLUSH FOOTING OPTION**

Concrete Qty. = 0.34 CY/FT (Below Gutter Line)
Steel Qty. = 63.5 LB/FT (Including Bars 5U)

NOTES:

1. GENERAL: Install the footing options per project-specific requirements, as defined on Sheet 2 and specified per the Plans.

Work with the supported 44" PPB and 56" PPB as shown on Sheets 3, 4, & 5.
2. OPTIONAL SLIP FORMING SUPPORT: The 1'-0" depth spread footing may be extended by 3" laterally beyond the face of the stem to provide support for a subsequent slip forming operation above. Do not adjust the steel reinforcement location for the additional concrete.
3. GUARDRAIL CONNECTION TAPERED TOE: For tapering the barrier as shown on Sheet 5, View D-D, bend Bars U away from the stem face as required. For this case, the cover requirement is variable for one side of the stem (only at the tapered toe locations).

10/20/2022 8:51:11 AM

LAST REVISION 11/01/17	REVISION	DESCRIPTION:		FY 2023-24 STANDARD PLANS	PIER PROTECTION BARRIER	INDEX 521-002	SHEET 6 of 8
---------------------------	----------	--------------	--	------------------------------	-------------------------	------------------	-----------------

BARRIER FOOTING OPTIONS

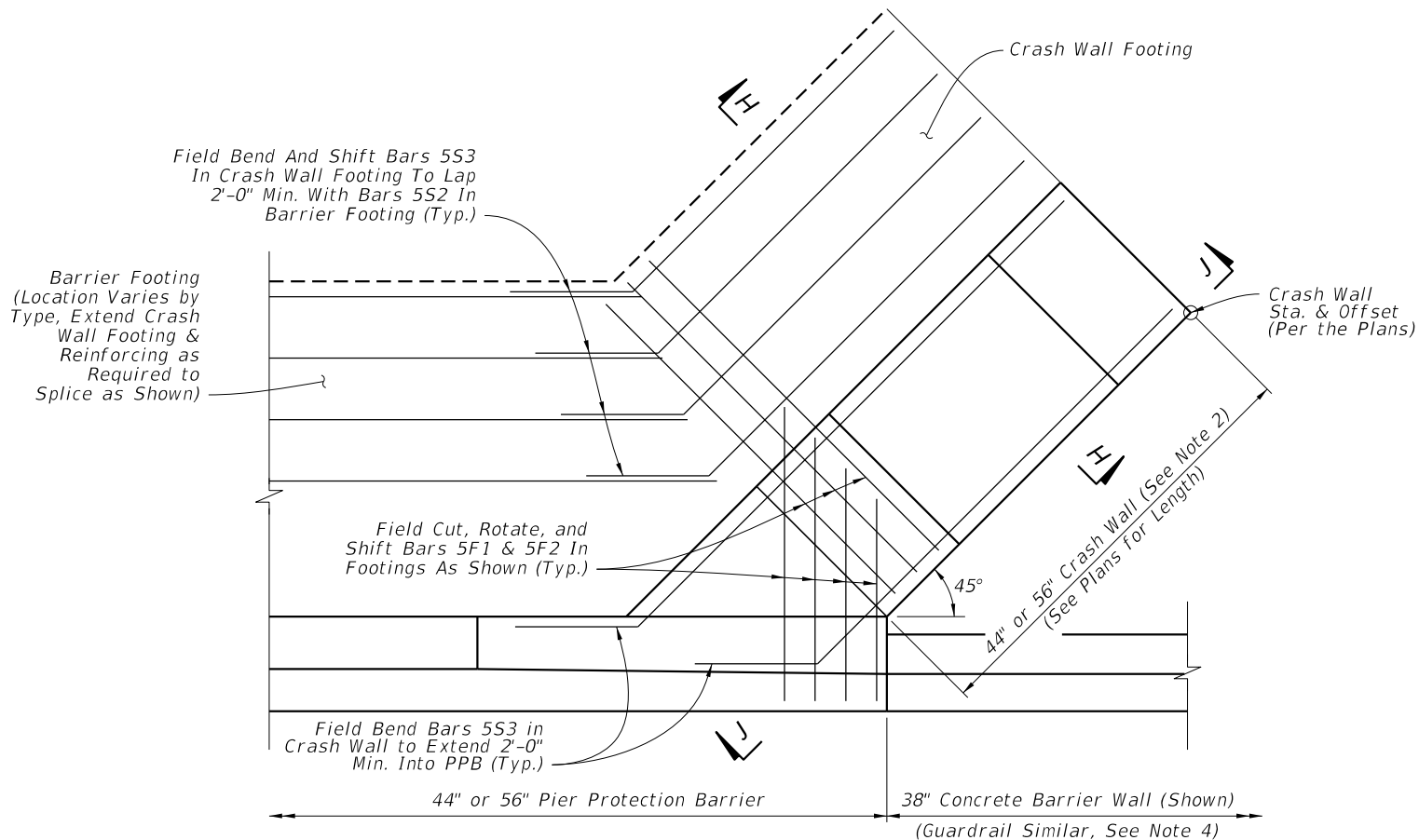

PLAN
(Schematic View - See Note 3)

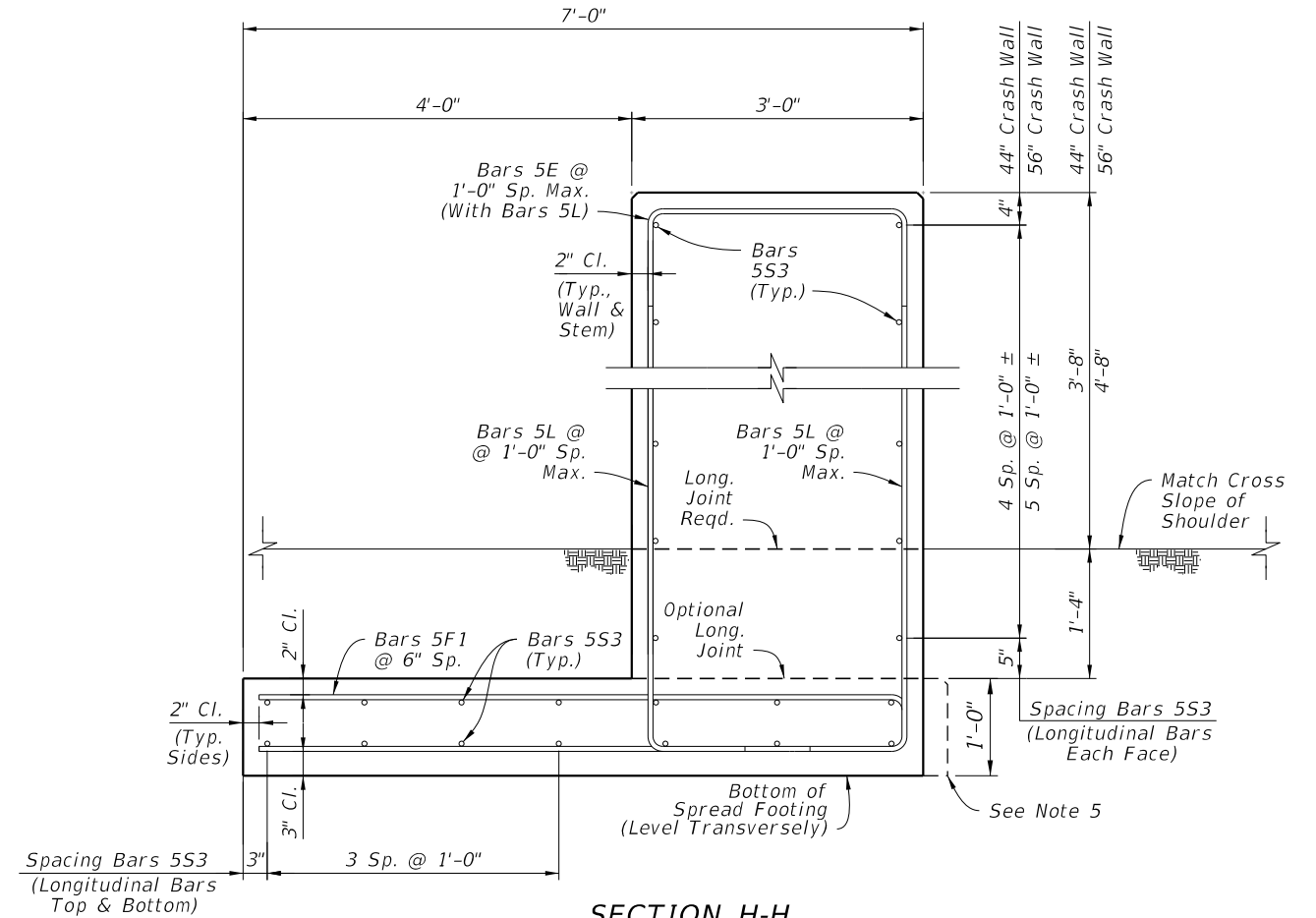

SECTION H-H
CRASH WALL

Concrete Qty. = 0.82 CY/FT (44" Crash Wall) or 0.93 CY/FT (56" Crash Wall)
Steel Qty. = 71.8 LB/FT (44" Crash Wall) or 76.0 LB/FT (56" Crash Wall)

NOTES:

1. GENERAL: Only where called for in the Plans, install the Crash Wall as a supplement for PPB. If applicable, see the Plans for the corresponding Station and Offset required.
For additional layout details, see Sheets 2 & 3.
2. CRASH WALL HEIGHT: Install the Crash Wall at a height which matches the adjacent PPB (either 44" or 56").
3. SCHEMATIC VIEWS: Only partial reinforcing is shown in the Schematic Views to establish a trend while keeping clarity. For all reinforcing steel locations and spacing requirements, see Section H-H.
4. GUARDRAIL CONNECTIONS: To facilitate guardrail connections, shift the Crash Wall 3 feet from the end of the PPB as shown on Sheets 2 & 3.
5. OPTIONAL SLIP FORMING SUPPORT: The 1'-0" depth spread footing may be extended by 3" laterally beyond the face of the wall to provide support for a subsequent slip forming operation above. Do not adjust the steel reinforcement location for the additional concrete.

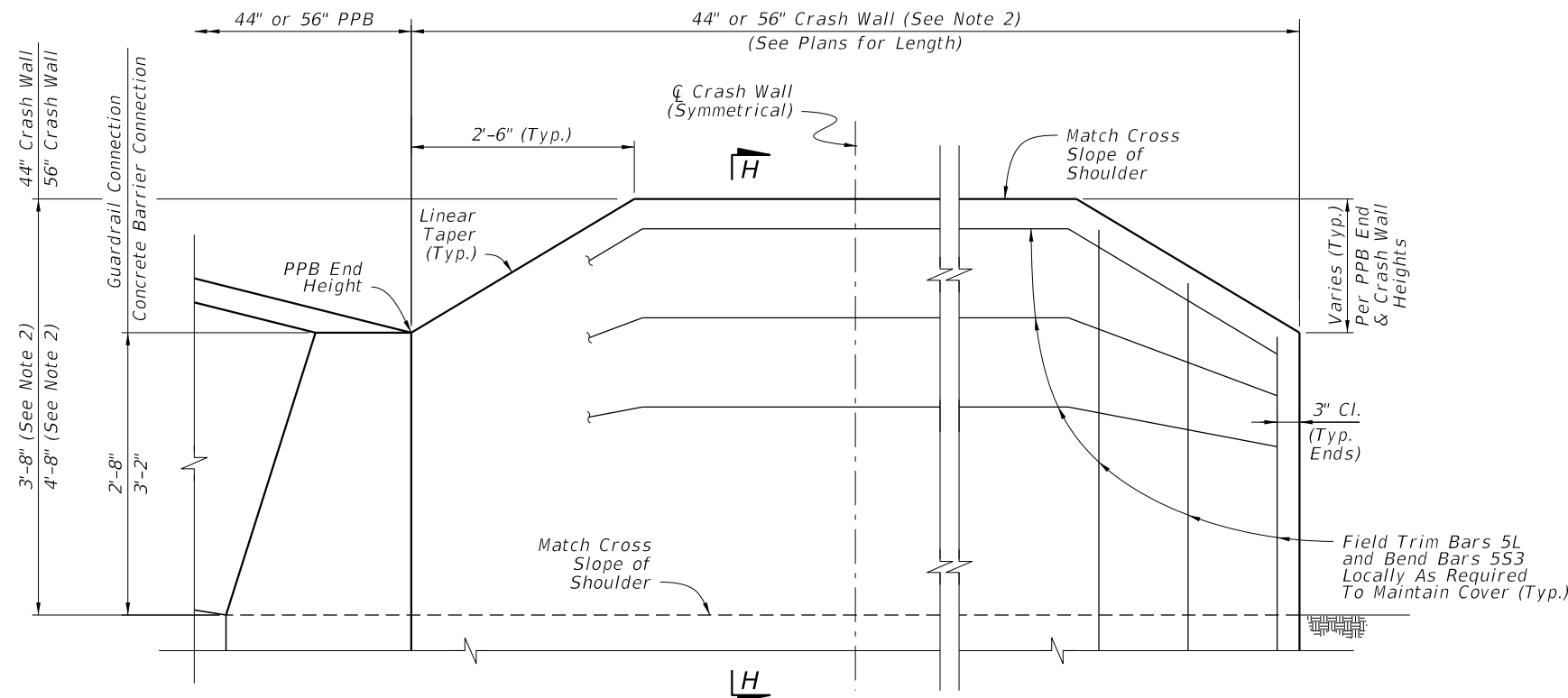

VIEW J-J CRASH WALL ELEVATION
(Schematic View - See Note 3)

CRASH WALL DETAILS

10/20/2022 8:51:12 AM

LAST REVISION 11/01/17	DESCRIPTION:		FY 2023-24 STANDARD PLANS	PIER PROTECTION BARRIER	INDEX	SHEET
			521-002		7 of 8	

BILL OF REINFORCING STEEL		
MARK	SIZE	LENGTH
V	5	7'-5"
U	5	8'-11"
R	5	6'-0"
F1	5	13'-9"
F2	5	Varies (Straight)
L	5	6'-5" / 7'-5"
E	5	4'-6"
S1	8	Varies (Straight)
S2, S3	5	Varies (Straight)

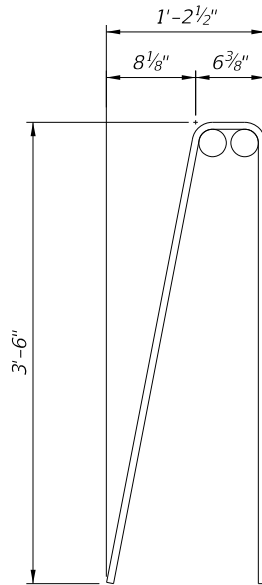

BARS 5V

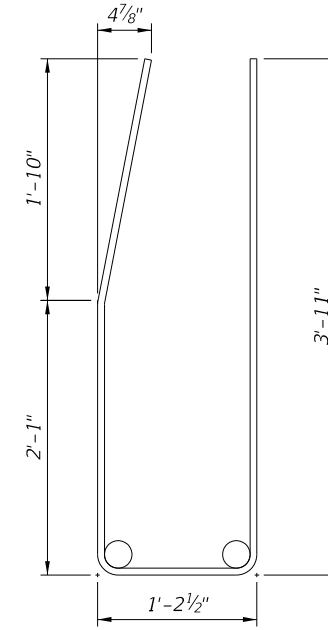

BARS 5U

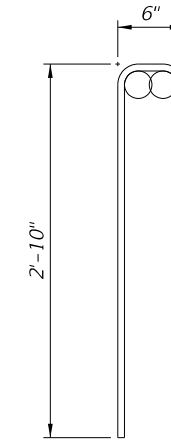

BARS 5R

NOTES:

1. Work with the Standard Bar Bending Details per Index 415-001.
2. All bar dimensions in the bending diagrams are out to out.

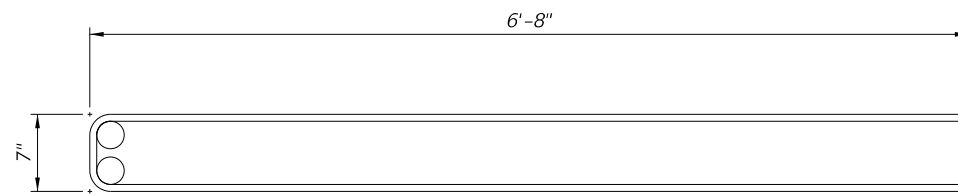

BARS 5F1

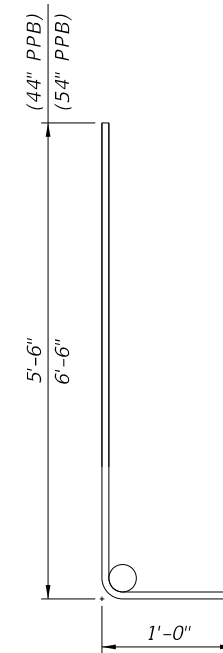

BARS 5L

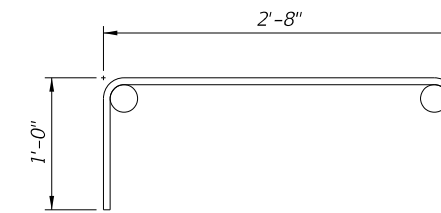

BARS 5E

BAR BENDING DIAGRAMS

10/20/2022 8:51:13 AM

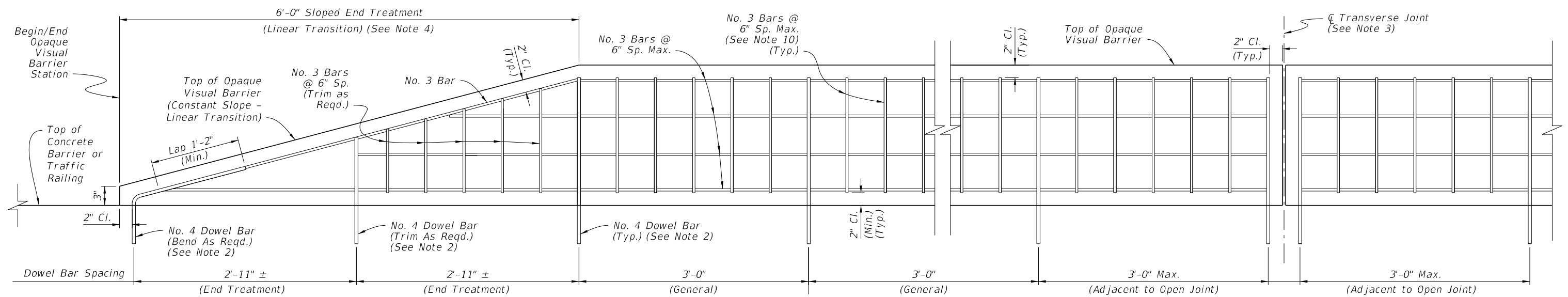

ELEVATION VIEW - OPAQUE VISUAL BARRIER

GENERAL NOTES:

- GENERAL:** Construct Opaque Visual Barrier (OVB) in accordance with Specification 521. Use either cast-in-place or precast panels with Class II Concrete and Class 3 Surface Finish. Do not cast OVB concrete monolithically with the Concrete Barrier or Traffic Railing; use an ASTM D6380, Class S, Type III Organic Felt bond breaker as needed.
- DOWEL BAR CONNECTION:** For the embedment in Concrete Barrier or Traffic Railing concrete, dowel bars must be either cast in place for new concrete or grouted in place for existing concrete. Embed the dowel bars to the corresponding depths shown, and use the bar lengths provided in the Dowel Bar Length Table.

At cast in place embedment locations, longitudinally shift the dowel bars only as required to avoid reinforcing steel in the Concrete Barrier or Traffic Railing.

At grouted embedment locations, drill 5/8" Ø holes to a depth of 6 1/4". Use only approved non-shrink grout on the APL. Drilling through existing reinforcing steel is permitted.
- TRANSVERSE JOINTS:** Place 1/2" Transverse Joints with a maximum spacing of 50'-0" and a minimum spacing of 20'-0". Use a consistent spacing where practical.

Without violating the above spacing requirements, place Transverse Joints matching the location and width of open joints in the supporting Concrete Barrier or Traffic Railing.
- SLOPED END TREATMENTS:** Regardless of the traffic direction, place Sloped End Treatments on all exposed ends of OVB, excluding leave-outs for barrier-mounted signs and light poles. See Note 7 below.
- BARRIER-MOUNTED SIGNS AND LIGHT POLES:** Where signs and barrier-mounted light pole structures conflict with placement of OVB, end and restart the OVB with a transverse vertical face located a longitudinal distance of 2" (±1/2") from the base of the structure. Follow the same reinforcing scheme and concrete cover requirement for the Transverse Joint shown herein. See Note 7 below.
- LARGE BARRIER-MOUNTED SIGN SUPPORTS:** See Sheet 2 for details. See Note 7 below.
- LEAVE-OUTS:** OVB leave-outs are longitudinal gaps in OVB segments required to accommodate barrier-mounted signs and light pole placement. Leave-outs up to 15 feet in length are included in OVB length measurement.
- ASYMMETRICAL CONCRETE BARRIER SECTIONS:** When mounting on top of an asymmetrical Concrete Barrier section (not shown), align the centerline of the OVB with the centerline of the top face of the Concrete Barrier section.
- SPLIT CONCRETE BARRIER SECTIONS:** For split Concrete Barrier sections that run separately (for vertical structures, bridges, etc.), OVB is only required on top of one of the Concrete Barrier sections. Place OVB on top of the Concrete Barrier section with the highest elevation. For these segments, mount barrier delineators on only the OVB face nearest the roadway (barrier mount other side). Longitudinally overlapping OVB runs are permitted where called for in the Plans, as designated with overlapping Begin and End Station OVB callouts.
- VERTICAL REINFORCING:** Place vertical No. 3 bars with the spacing shown, except that No. 3 bars at the dowel bar locations may be shifted longitudinally to fit or they may be omitted at the contractor's option.
- OPTIONAL WELDED WIRE REINFORCEMENT:** With the approval of the Engineer, the No. 3 bars shown herein may be replaced with welded wire reinforcement in accordance with Specification 415. Use welded wire reinforcement of equal or greater strength than the bars being replaced; maintain the same cover requirements with equivalent or smaller spacing.
- VARIABLE HEIGHT CONCRETE BARRIERS:** See Sheet 2 for details.
- CONCRETE BARRIER AND TRAFFIC RAILING TRANSITIONS BETWEEN DIFFERING SECTIONS:** Transition the OVB section using a method similar to the OVB Linear Bottom Transition shown in Elevation View 'B' on Sheet 2, except adjust the longitudinal length of the transition as required.

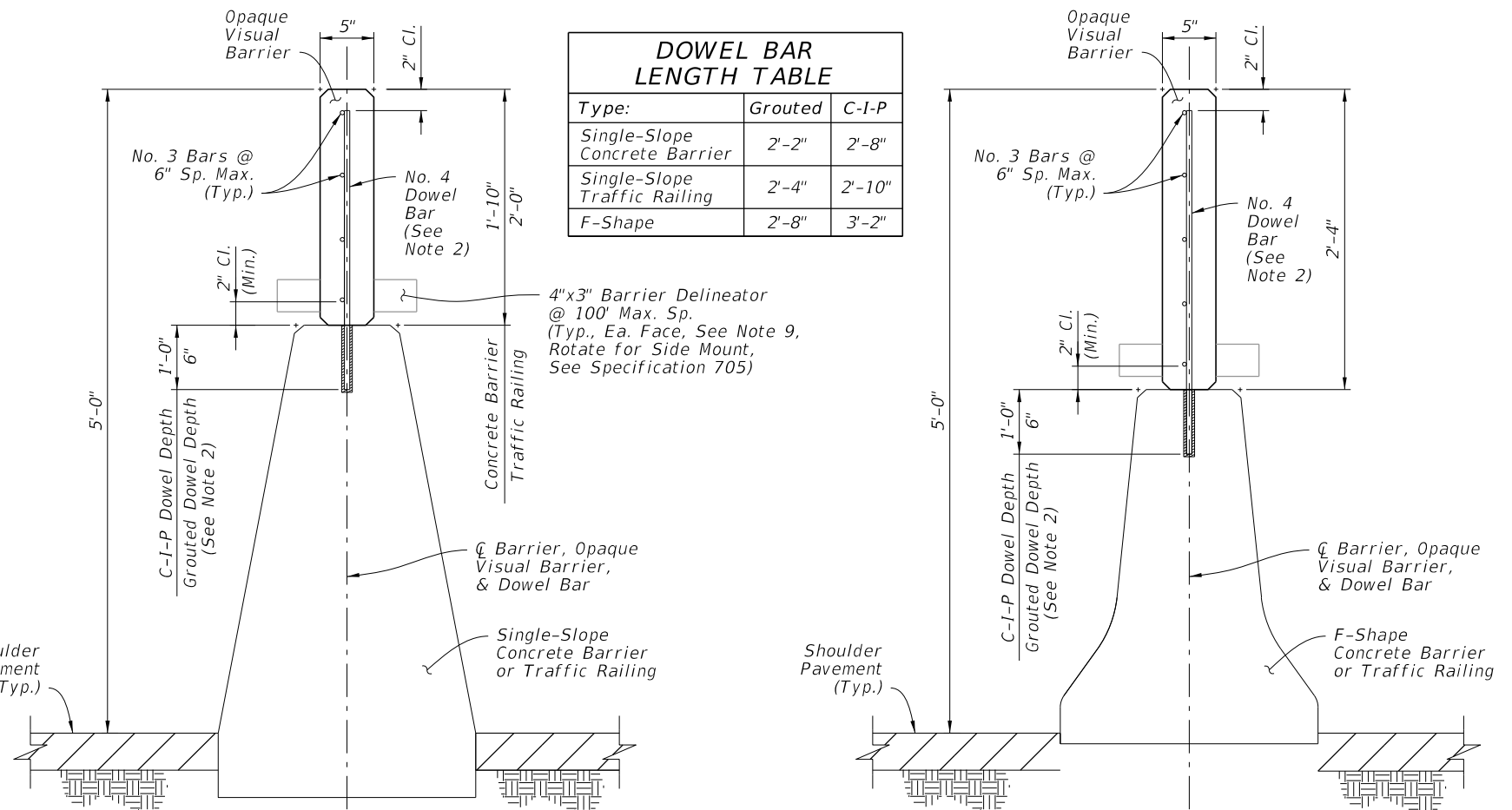

DOWEL BAR LENGTH TABLE		
Type:	Grouted	C-I-P
Single-Slope Concrete Barrier	2'-2"	2'-8"
Single-Slope Traffic Railing	2'-4"	2'-10"
F-Shape	2'-8"	3'-2"

SECTION VIEW - OPAQUE VISUAL BARRIER FOR MEDIAN SINGLE-SLOPE CONCRETE BARRIER OR TRAFFIC RAILING

SECTION VIEW - OPAQUE VISUAL BARRIER FOR MEDIAN F-SHAPE CONCRETE BARRIER OR TRAFFIC RAILING

10/20/2022 8:51:13 AM

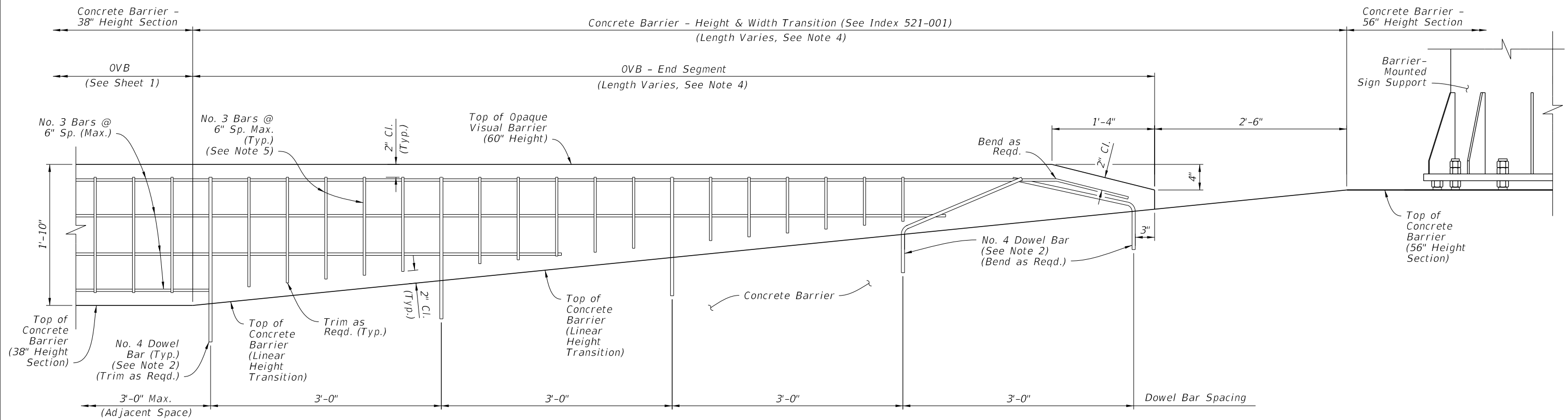

ELEVATION VIEW 'A' - OVB END SEGMENT AT CONCRETE BARRIER HEIGHT TRANSITION FROM 38" HEIGHT TO 56" HEIGHT SECTION (REVERSE DIRECTION SIMILAR BY OPPOSITE HAND)

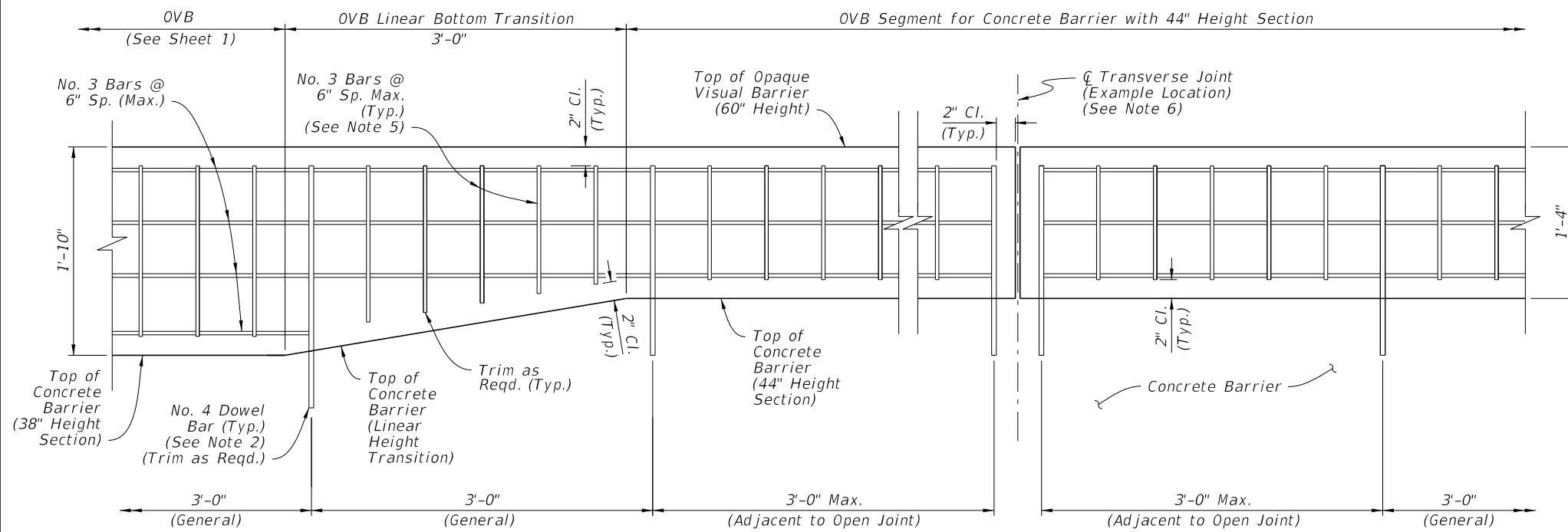

ELEVATION VIEW 'B' - OVB SEGMENT FOR CONCRETE BARRIER WITH 44" HEIGHT SECTION (OVB LINEAR BOTTOM TRANSITION SHOWN, REVERSE DIRECTION SIMILAR BY OPPOSITE HAND)

NOTES:

- LATERAL DIMENSIONS:** Maintain the OVB section width and lateral placement as defined on Sheet 1.
- DOWEL BAR LENGTHS & CONNECTIONS:** For the differing OVB section heights, trim or adjust the dowel bar lengths as required to meet the clearances shown while maintaining the dowel bar connection requirements of Sheet 1.
Elevation View 'A' - For the two dowel bars closest to the OVB end location, use full dowel bar lengths and bend as shown to maintain clearances. Overlapping dowel bars may deviate from the lateral centerline as required.
- DOWEL BAR SPACING:**
Elevation View 'B' - The dowel locations shown in this detail are examples only, and may shift to maintain the spacing pattern that is governed by adjacent OVB. Maintain the dowel bar spacing scheme as defined on Sheet 1; place dowel bars within the OVB Linear Bottom Transition as required.
- SEGMENT LENGTHS:**
Elevation View 'A' - The length of the OVB End Segment is governed by the length of linear width and height transition of the Concrete Barrier.
Elevation View 'B' - The length of the reduced-section OVB segment is governed by the length of Concrete Barrier with 44" Height Section.
- VERTICAL REINFORCING:** For the differing OVB section heights, trim or adjust the vertical No. 3 Bar lengths as required to meet the clearances shown.
- TRANSVERSE JOINTS:**
Follow the requirements of Sheet 1.
Elevation View 'A' - Do not place Transverse Joints within the End Segment.
Elevation View 'B' - Maintain the Transverse Joint spacing scheme as defined on Sheet 1; place dowel bars within the OVB Linear Bottom Transition as required.

10/20/2022 8:51:14 AM

LAST REVISION 11/01/18	REVISION	DESCRIPTION:		FY 2023-24 STANDARD PLANS	OPAQUE VISUAL BARRIER	INDEX 521-010	SHEET 2 of 2
---------------------------	----------	--------------	---	------------------------------	-----------------------	------------------	-----------------

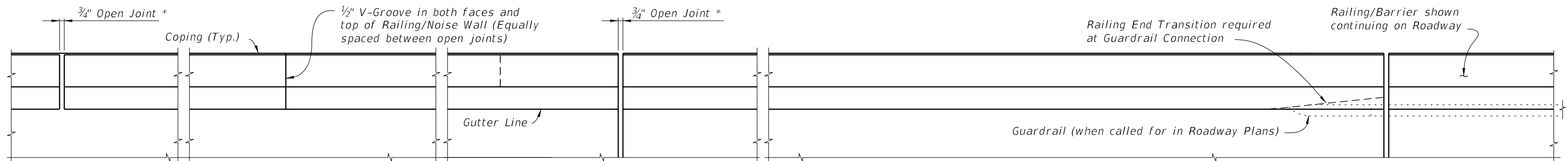

* Construct 3/4" Open Joints plumb at Construction Joints in Junction Slabs or Footings.

PLAN
(Reinforcing Steel not shown for clarity)

CROSS REFERENCE:
 For Section A-A see Sheet 3.
 For Section C-C and Detail "A" see Sheet 5.
 For Wall mounted Barrier/Noise Wall Details see Index 521-512.
 For Footing mounted Barrier/Noise Wall Details see Index 521-513 (T-Shaped), 521-514 (L-Shaped) or 521-515 (Trench).

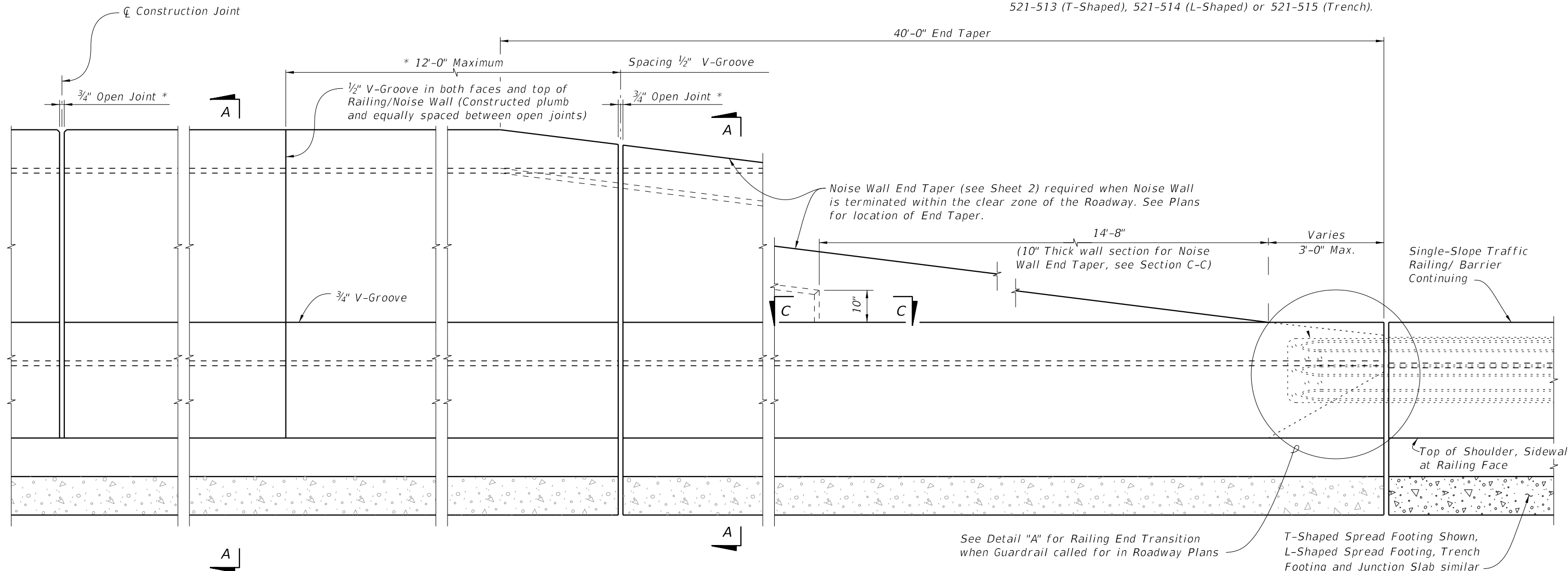

ELEVATION

(INSIDE FACE OF CONCRETE BARRIER/NOISE WALL WITH T-SHAPED FOOTING SHOWN,
 (Other footings similar, Reinforcing steel not shown for clarity)

- NOTES:
1. Work this Index with Indexes 521-512 through 521-515.
 2. The Concrete Barrier/Noise Wall and joints shall be constructed plumb.
 3. Concrete:
 - A. Class II for slightly aggressive environments.
 - B. Class IV for moderately or extremely aggressive environments.
 4. Provide 3/4" Open Joints spaced between 30 feet minimum to 90 feet maximum. Align Open Joints with construction joints in the Junction Slab or Footing. Provide additional reinforcing (see Sheet 2) at each open joint.
 5. Install Barrier Delineators 2'-4" above the riding surface in accordance with Specification Section 705. Match the Barrier Delineators color (White or Yellow) to the near edgeline.
 6. Slip forming of the barrier portion is permitted.
 - A. Stem walls may be widened, at no additional cost, to accommodate slip forming.

10/20/2022 8:51:16 AM

LAST REVISION 11/01/19	REVISION	DESCRIPTION:		FY 2023-24 STANDARD PLANS	CONCRETE BARRIER/NOISE WALL (8'-0")	INDEX 521-510	SHEET 1 of 5
---------------------------	----------	--------------	--	------------------------------	-------------------------------------	------------------	-----------------

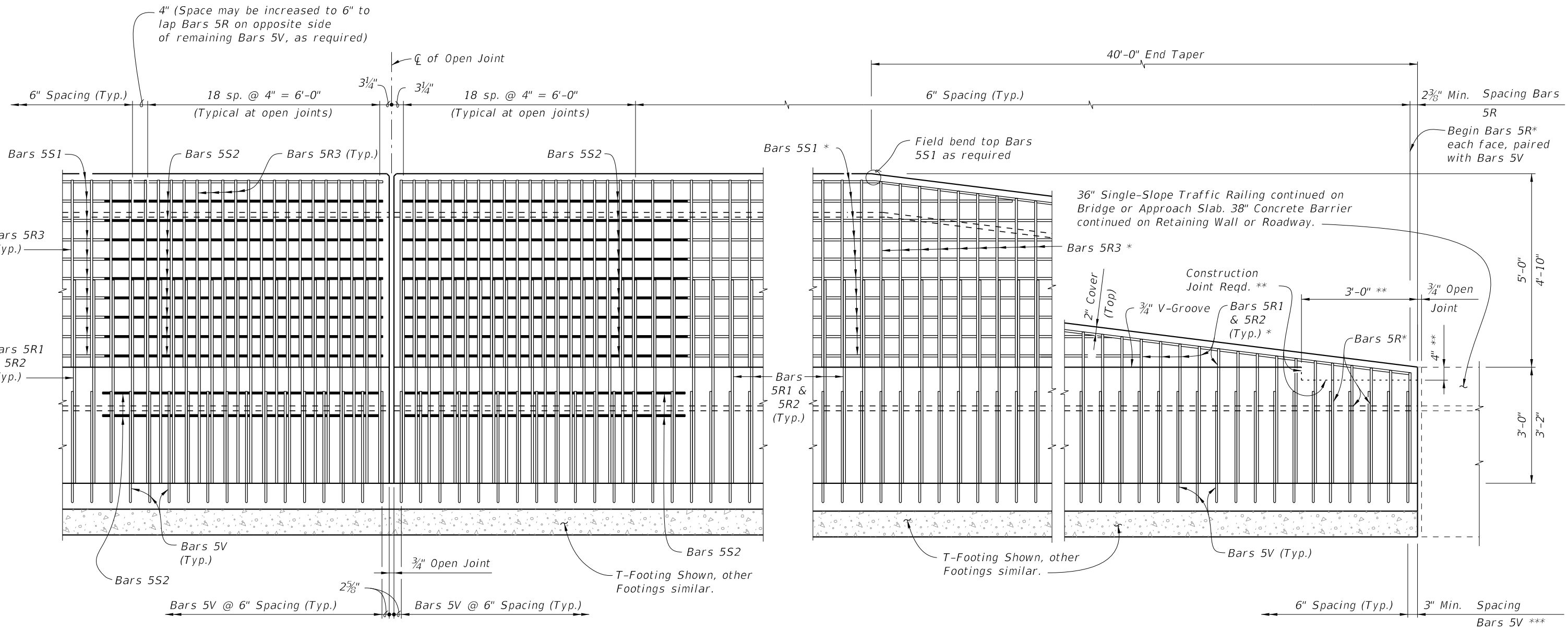

ELEVATION OF BARRIER/NOISE WALL REINFORCING STEEL AT OPEN JOINT
 (Bars 5S1 in Barrier not shown for clarity)
 (Footing or Junction Slab Details not shown)

ELEVATION OF BARRIER/NOISE WALL END TAPER (ADJACENT TO CONCRETE BARRIER SHOWN, GUARDRAIL ATTACHMENT SIMILAR SEE DETAIL "A", SHEET 5)
 (Bars 5S1 in Railing not shown for clarity)
 (Footing or Junction Slab Details not shown)

- NOTES:
- * Field Cut Bars 5R & 5S1 to maintain clearance.
 - ** Terminate 3/4" V-groove at construction joint & cast top of railing with End Taper.
 - *** Bar spacing shown for Bars 5V only applies when Single-Slope Concrete Barrier continues. For transition to guardrail see Sheet 5. Work Traffic/ Railing Noise Wall reinforcing with Index 521-512 (Junction Slab) or Index 521-513 through 521-515 (T, L or Trench Footings)

10/20/2022 8:51:17 AM

LAST REVISION 11/01/18	REVISION	DESCRIPTION:		FY 2023-24 STANDARD PLANS	CONCRETE BARRIER/NOISE WALL (8'-0")	INDEX 521-510	SHEET 2 of 5
---------------------------	----------	--------------	--	------------------------------	-------------------------------------	------------------	-----------------

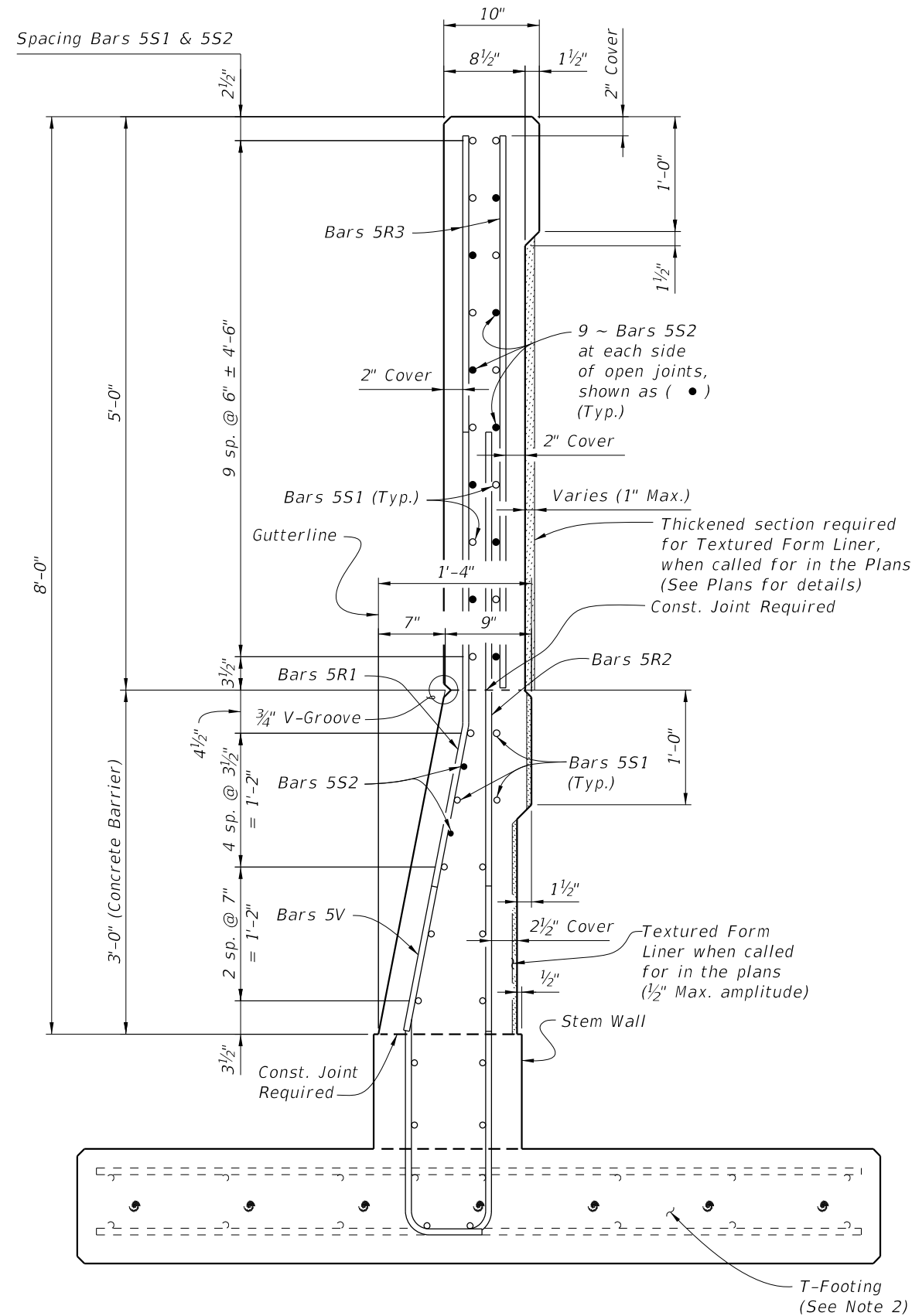

SECTION A-A
TYPICAL SECTION THRU CONCRETE BARRIER/NOISE WALL AT OPEN JOINT
 (Section Thru T-Footing Shown, Section Thru
 Junction Slab, L or Trench Footings similar)

NOTES:

1. Bars 5V shown are for T-Shape footings.
 5V for Junction Slab, L-Shape and Trench footings are similar.
2. Foundation Details:
 Index 521-512 (Junction Slab)
 Index 521-513 (T-Shape)
 Index 521-514 (L-Shape)
 Index 521-515 (Trench)

CROSS REFERENCE:

- For locations of Section A-A see Sheet 1.
- For location of View B-B, see Sheet 5.
- For Detail "A", see Sheet 5

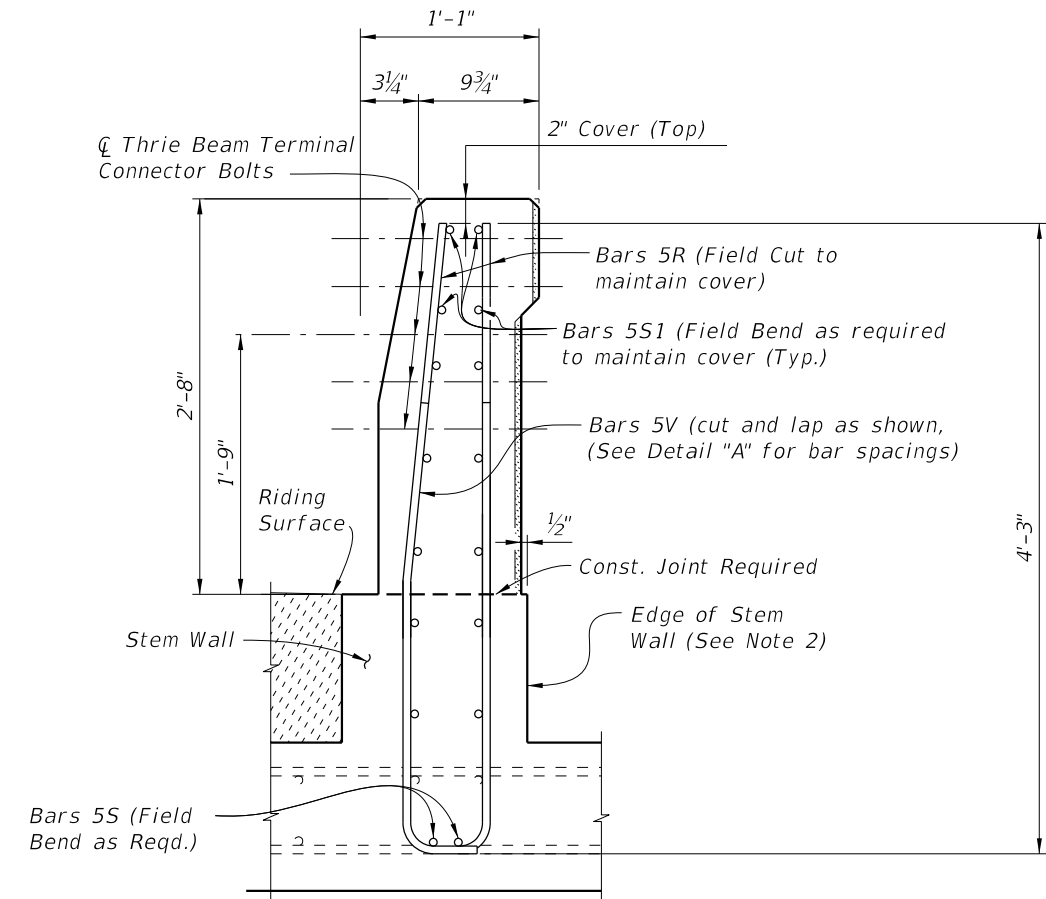

VIEW B-B
END VIEW OF RAILING END TRANSITION FOR
GUARDRAIL ATTACHMENT
 (T-Footing shown, Junction Slab, L or Trench Footings similar)

10/20/2022 8:51:18 AM

LAST REVISION 11/01/18	REVISION	DESCRIPTION:		FY 2023-24 STANDARD PLANS	CONCRETE BARRIER/NOISE WALL (8'-0")	INDEX 521-510	SHEET 3 of 5
---------------------------	----------	--------------	---	--	--	-------------------------	------------------------

REINFORCING STEEL BENDING DIAGRAMS

BILL OF REINFORCING STEEL

MARK	SIZE	LENGTH
R1	5	5'-2"
R2	5	5'-2½"
R3	5	4'-10"
S1	5	As Req'd.
S2	5	7'-3"
V (Wall)	5	6'-6½"
V (T-Footing)	5	7'-8½"

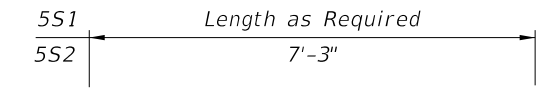

BARS 5S1 & 5S2

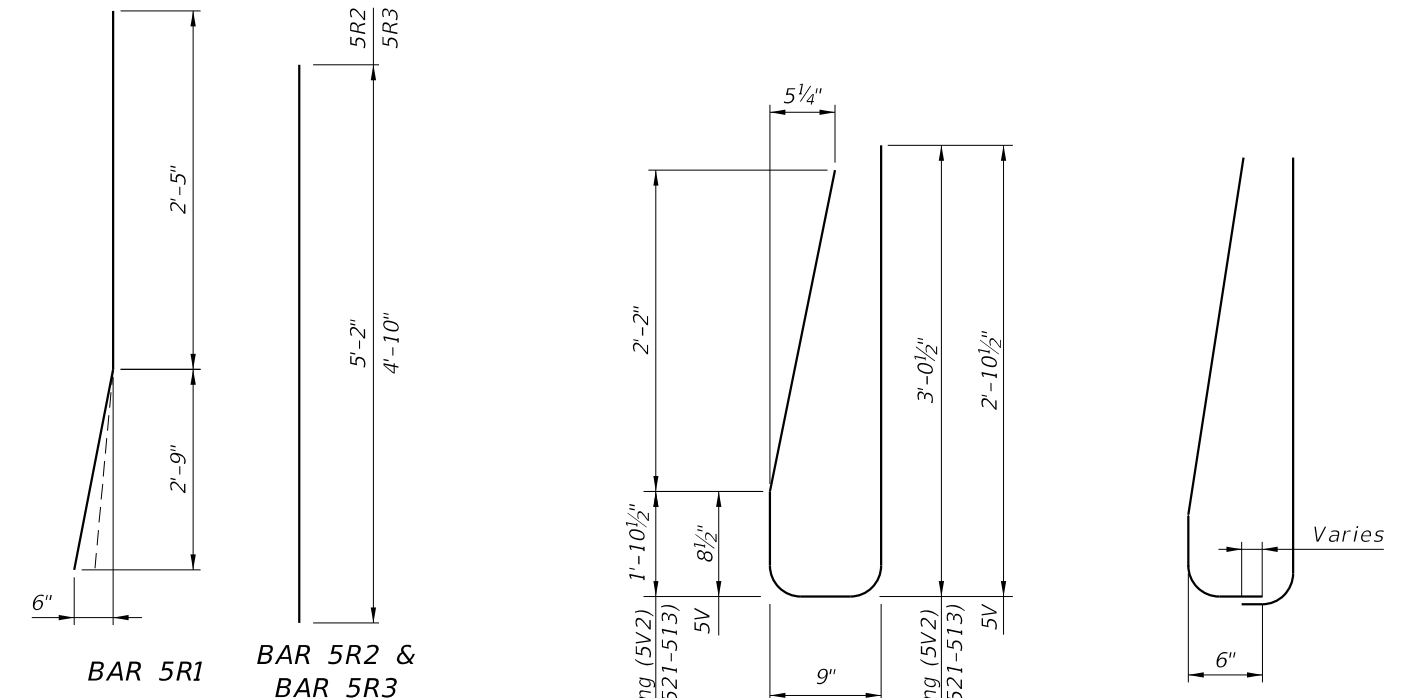

(Field Cut and Bend for Railing End Transition)

STIRRUP BAR 5V

END STIRRUP BAR 5V To Be Field Cut (Railing End Transition)

REINFORCING STEEL NOTES:

1. All bar dimensions in the bending diagrams are out to out.
2. All reinforcing steel at the open joints shall have a 2" minimum cover.
3. Bars 5R shall be one continuous or lap spliced bar. No mechanical couplers are permitted.
4. Bars 5S1 may be continuous or spliced at the construction joints. Lap splices for Bars 5R, 5S1 and 5W shall be a minimum of 2'-2".
5. The Contractor may use Welded Wire Reinforcement (WWR) when approved by the Engineer. WWR must consist of deformed wire meeting the requirements of Specification Section 931.
6. See Index 521-514 and 521-515 for L-shaped and Trench footing vertical reinforcing.

CROSS REFERENCE:
See Index 521-512 for Junction Slab Details and Indexes 521-513 thru 521-515 for additional footing details.

ESTIMATED TRAFFIC RAILING/NOISE WALL QUANTITIES

ITEM	UNIT	QUANTITY
Concrete (Railing)	CY/LF	0.107
Concrete (Noise Wall)	CY/LF	0.136
Reinforcing Steel (Typical)	LB/LF	69.36
Additional Reinf. @ Open Joint	LB	226.85

(The above quantities are based on the Concrete Barrier/ Noise wall typical section, (excluding junction slab or footing)

10/20/2022 8:51:19 AM

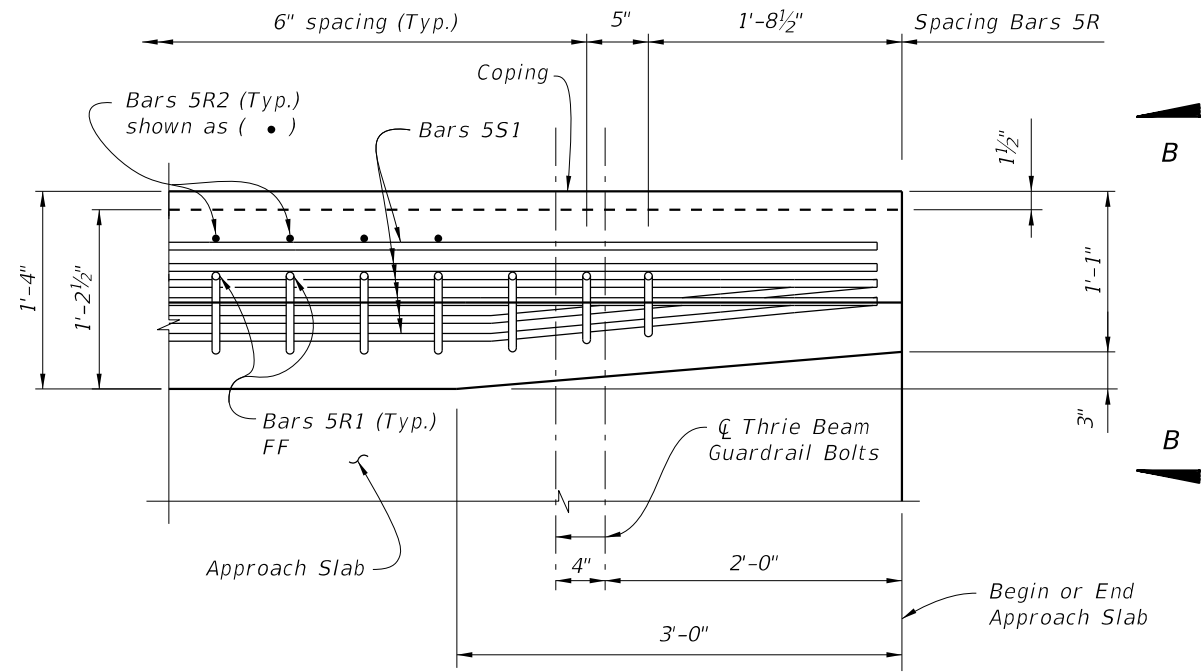

PLAN - RAILING END TRANSITION
(Showing Bars 5R, and Bars 5S1)
(Bars 5V not shown for Clarity)

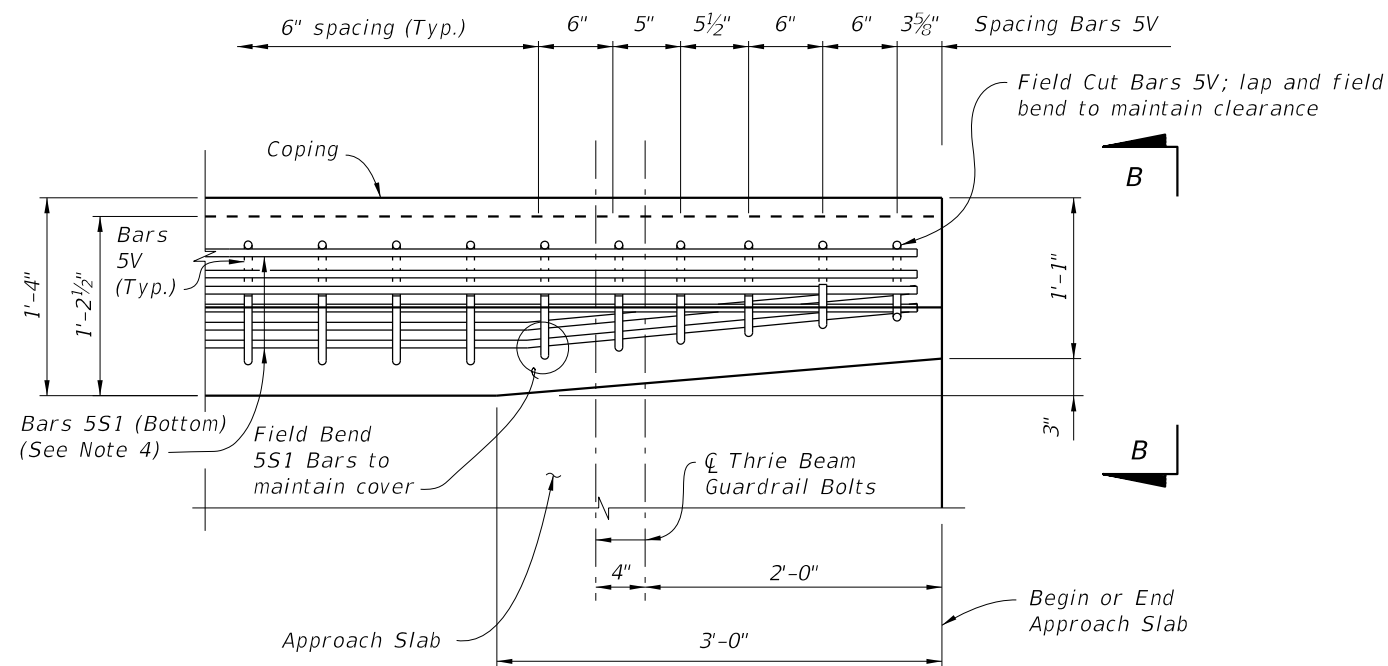

PLAN - RAILING END TRANSITION
(Showing Bars 5V and Bars 5S1)
(Bars 5R not shown for Clarity)

DETAIL "A"

DETAIL "A" NOTES:

1. Begin placing Railing Bars 5V at the railing end and proceed toward the guardrail (thrie beam) terminal connector to ensure placement of guardrail bolt holes. Pair Bars 5R with Bars 5V as shown. Clearance of Bars 5R & 5V to guardrail bolt holes shall be checked to prevent cutting of bars if bolt holes are to be drilled. Shift bars locally where conflicts occur.
2. For Guardrail connection details see Index 536-001.
3. Omit Railing End Transition if a Single-Slope Concrete Barrier/ Barrier continues beyond the End Taper. See the Plan Sheets.
4. Field cut Bars 5R2 to maintain cover. Field cut Bars 5V and lap as necessary to maintain cover; field cut & bend Bars 5R1 front leg (more plumb) to maintain cover and tie to S1 Bars. (See Sheet 1 Notes 1 and 2)

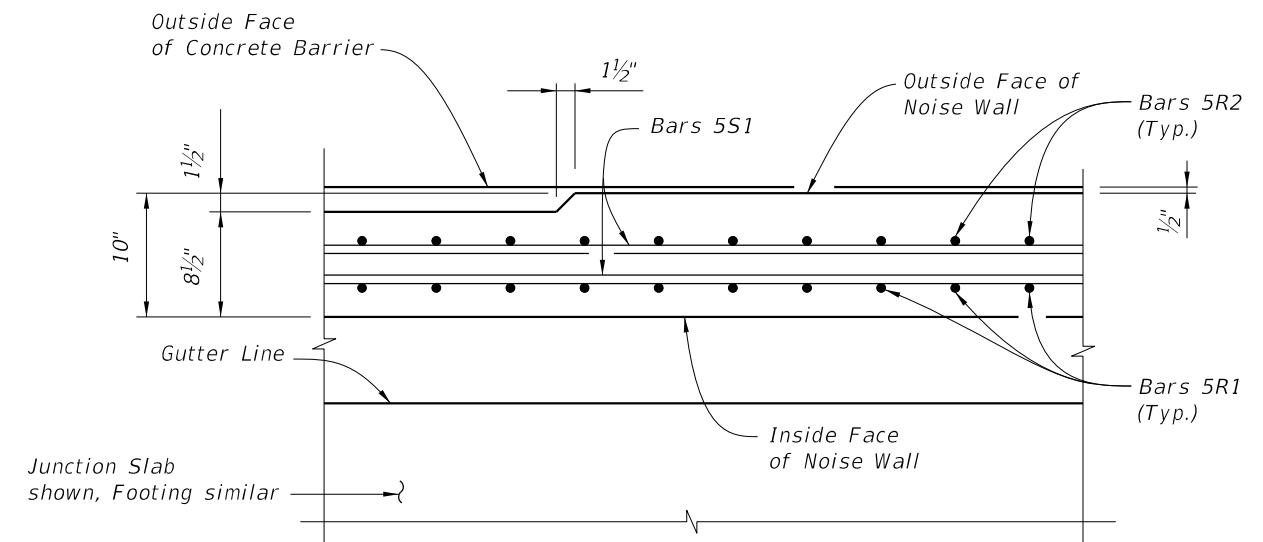

SECTION C-C
THRU NOISE WALL END TAPER

CROSS REFERENCE:
For location of Detail "A" see Sheet 1.
For location of Section C-C see Sheet 1.
For View B-B see Sheet 3.

10/20/2022 8:51:20 AM

LAST REVISION 11/01/18	REVISION	DESCRIPTION:		FY 2023-24 STANDARD PLANS	CONCRETE BARRIER/NOISE WALL (8'-0")	INDEX 521-510	SHEET 5 of 5
---------------------------	----------	--------------	--	------------------------------	-------------------------------------	------------------	-----------------

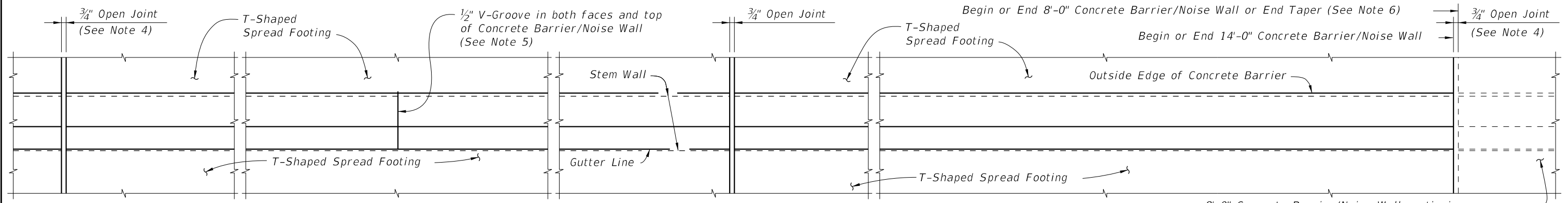

CROSS REFERENCE:
 For Section A-A, Detail "A" and Estimated Quantities, see Sheet 3.
 For Expansion Joint Detail in Footing, see Index 521-513, 521-514 or 521-515.

**PLAN (Reinforcing Steel not shown for clarity)
 (T-Shaped Spread Footing Shown, L-Shaped Spread Footing and Trench Footing Similar)**

Concrete Barrier/NOISE WALL NOTES

1. Construct the Concrete Barrier/Noise Wall and joints plumb; do not construct the Concrete Barrier/Noise Wall perpendicular to the roadway surface.
2. **CONCRETE:** Concrete will be in accordance with Specification Section 346.
 A. Class II concrete for slightly aggressive environments.
 B. Class IV concrete for moderately or extremely aggressive environments.
3. Construct $\frac{3}{4}$ " Open Joints plumb and perpendicular or radial to Gutter Line. Provide at 90'-0" maximum intervals as shown. $\frac{3}{4}$ " Open Joint locations are to coincide with $\frac{3}{4}$ " Expansion Joints in footings.
4. Construct $\frac{1}{2}$ " V-Grooves plumb and provide at 30'-0" maximum intervals as shown. Space V-Grooves equally between $\frac{3}{4}$ " Open Joints and/or Begin or End Concrete Barrier/Noise Wall.
5. 14'-0" Noise Wall End Taper is required when adjacent to an 8'-0" Concrete Barrier/Noise Wall and may be used when an 8'-0" Concrete Barrier/Noise Wall End Taper is provided (see Index 521-510 for details). See Roadway Plans for Concrete Barrier/Noise Wall End Treatment.
6. Work this Index with Index 521-510 - Concrete Barrier/Noise Wall (8'-0") and one or more of the following:
 A. Index 521-513 - Concrete Barrier/Noise Wall T-Shaped Spread Footing,
 B. Index 521-514 - Concrete Barrier/Noise Wall L-Shaped Spread Footing or
 C. Index 521-515 - Concrete Barrier/Noise Wall Trench Footing.

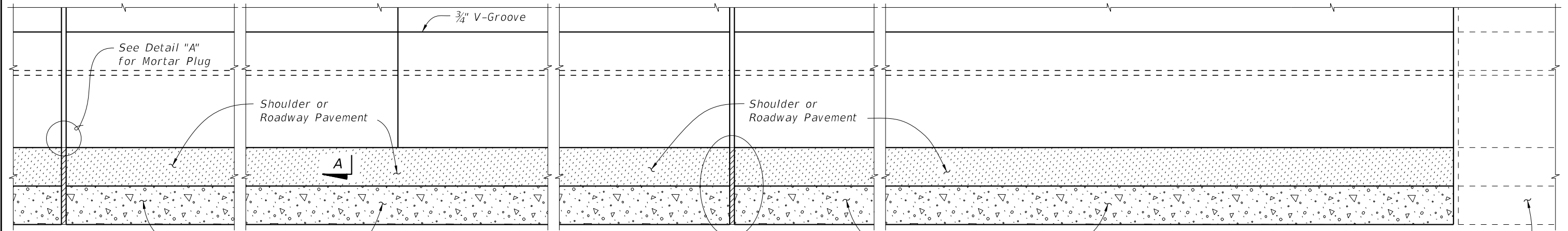
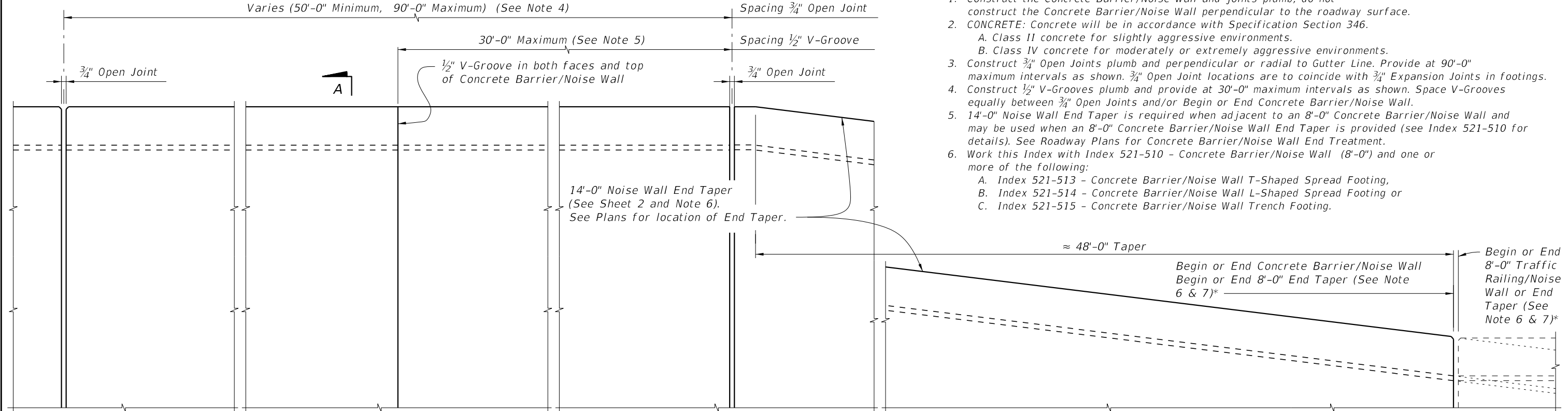

**ELEVATION OF INSIDE FACE OF CONCRETE BARRIER/NOISE WALL
 (Reinforcing Steel not shown for clarity)
 (T-Shaped Spread Footing Shown, L-Shaped Spread Footing and Trench Footing Similar)**

8'-0" Concrete Barrier/Noise Wall continuing or End Taper on Approach Slab or Roadway (shown)
 * $\frac{3}{4}$ " Open Joint may be omitted when 8'-0" Railing/Noise Wall End Taper is adjacent to a 14'-0" Concrete Barrier/Noise Wall End Taper.

10/20/2022 8:51:21 AM

LAST REVISION 11/01/18	DESCRIPTION:	 FY 2023-24 STANDARD PLANS	CONCRETE BARRIER/NOISE WALL (14'-0")	INDEX 521-511	SHEET 1 of 3
---------------------------	--------------	--	---	-------------------------	------------------------

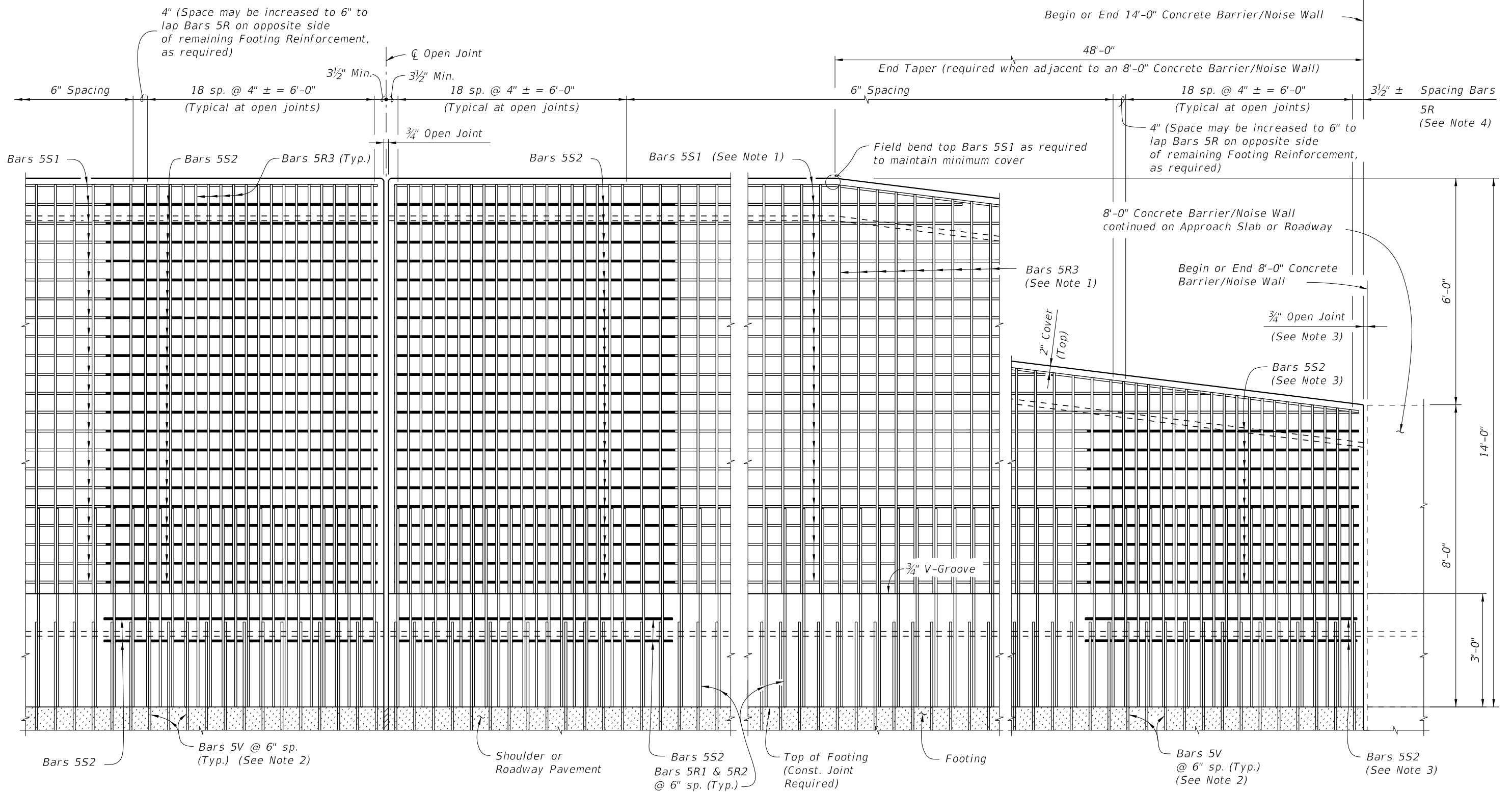

ELEVATION OF CONCRETE BARRIER/NOISE WALL REINFORCING STEEL
(Bars 5S1 in Railing not shown for clarity)

ELEVATION OF CONCRETE BARRIER/NOISE WALL END TAPER
(Bars 5S1 in Railing not shown for clarity)

NOTES:

1. Field Cut Bars 5R & 5S1 in Noise Wall End Taper as required to maintain minimum cover.
2. See Index 521-513, 521-514 and 521-515 for footing reinforcement.
3. 3/4" Open Joint may be omitted when 8'-0" Railing/Noise Wall End Taper is adjacent to a 14'-0" Concrete Barrier/Noise Wall End Taper as shown on Sheet 1. See Index 521-510 for reinforcement details and spacing. Bars 5S2 are not required when 3/4" Open Joint is omitted.
4. Bar spacing shown is along the Gutter Line.

10/20/2022 8:51:23 AM

LAST REVISION 11/01/18	REVISION	DESCRIPTION:		FY 2023-24 STANDARD PLANS	CONCRETE BARRIER/NOISE WALL (14'-0")	INDEX 521-511	SHEET 2 of 3
---------------------------	----------	--------------	---	------------------------------	--------------------------------------	------------------	-----------------

Spacing Bars 5S1 & 5S2

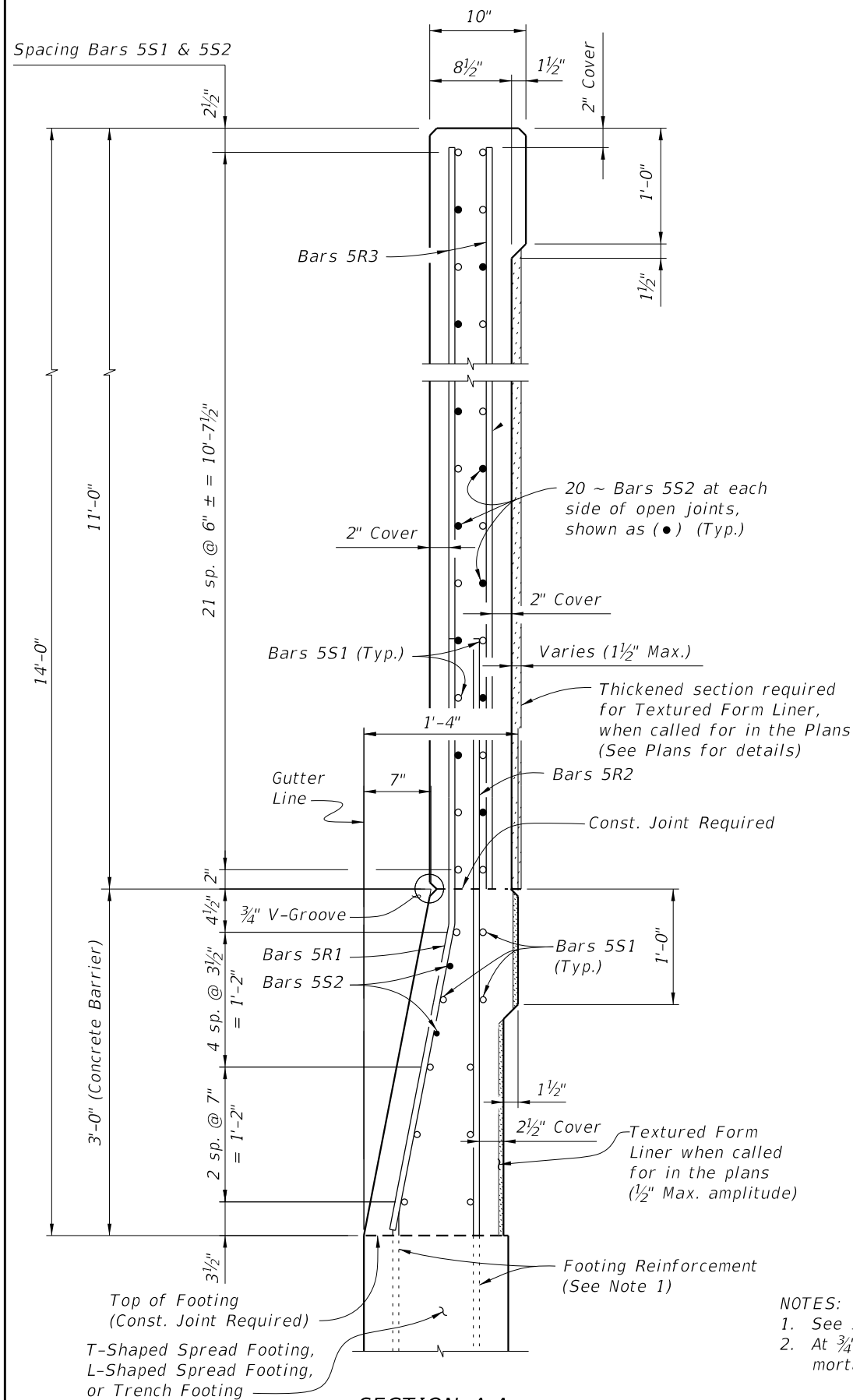

SECTION A-A
TYPICAL SECTION THRU CONCRETE BARRIER/NOISE WALL

NOTES:

1. See Index 521-513, 521-514 or 521-515 for footing reinforcement.
2. At 3/4" Open Joints, plug the lower 3" portion of the open joint by filling it with mortar in accordance with Specification Section 400.

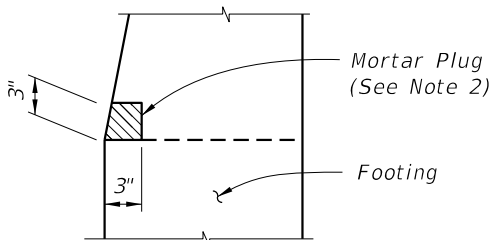

DETAIL "A" -
SECTION AT OPEN JOINT

REINFORCING STEEL BENDING DIAGRAMS

BILL OF REINFORCING STEEL

MARK	SIZE	LENGTH
R1	5	5'-2"
R2	5	5'-2 1/2"
R3	5	10'-10"
S1	5	AS REQD.
S2	5	7'-3"

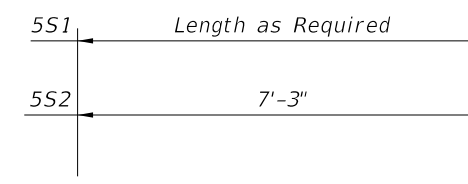

BARS 5S1 & 5S2

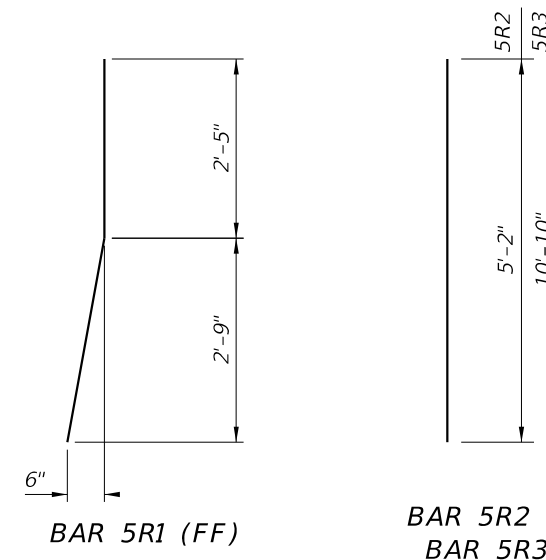

BAR 5R1 (FF)

BAR 5R2 &
BAR 5R3

REINFORCING STEEL NOTES:

1. All bar dimensions in the bending diagrams are out to out.
2. All reinforcing steel at the open joints will have a 2" minimum cover.
3. Bars 5R may be continuous or spliced at construction joints. Lap splices for Bars 5R, and 5S1 will be a minimum of 2'-2".
4. The Contractor may use Welded Wire Reinforcement (WWR) when approved by the Engineer. WWR must consist of Deformed wire meeting the requirements of Specification Section 931.

ESTIMATED CONCRETE BARRIER/NOISE WALL QUANTITIES

ITEM	UNIT	QUANTITY
Concrete (Concrete Barrier)	CY/FT	0.107
Concrete (Noise Wall, excluding any thickening)	CY/FT	0.293
Reinforcing Steel (Railing/Noise Wall) (Bars R1, R2, R3, S1 & V)	LB/FT	100.31
Additional Reinf. @ Open Joint (Railing/Noise Wall)	LB	397.38

CROSS REFERENCE:

For locations of Section A-A and Detail "A", see Sheet 1.

10/20/2022 8:51:24 AM

LAST REVISION	DESCRIPTION:
11/01/18	



FY 2023-24
STANDARD PLANS

CONCRETE BARRIER/NOISE WALL (14'-0")

INDEX
521-511

SHEET
3 of 3

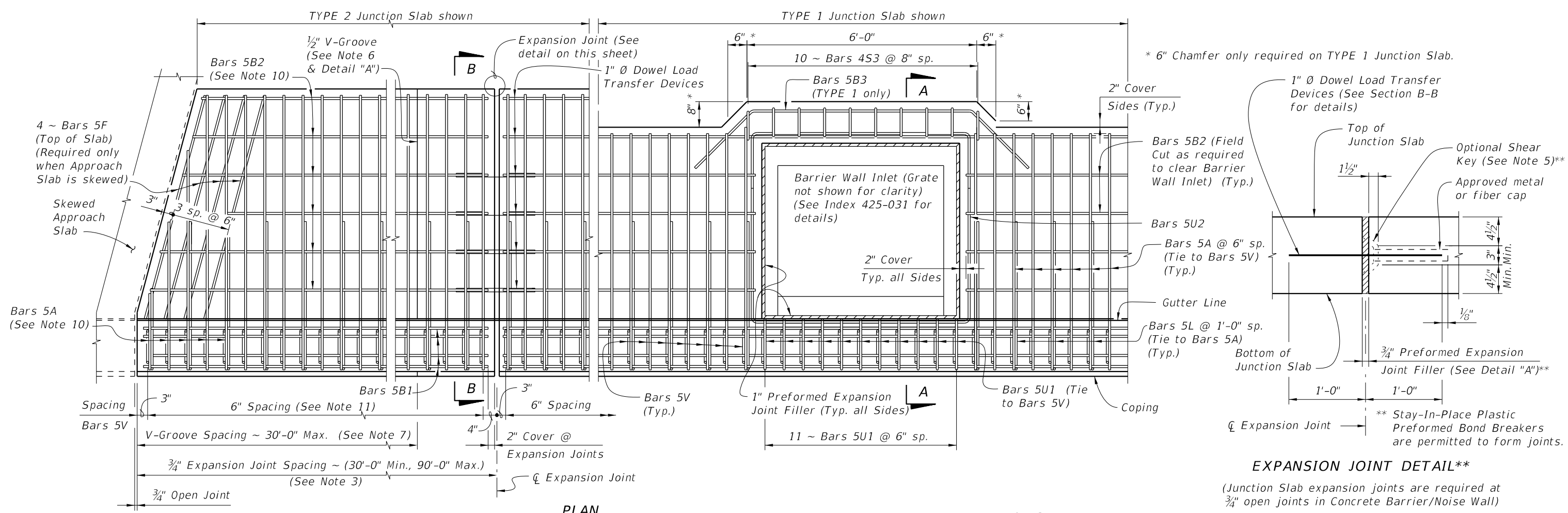

PLAN
JUNCTION SLAB ADJACENT TO SKEWED APPROACH SLAB AND WITH BARRIER WALL INLET

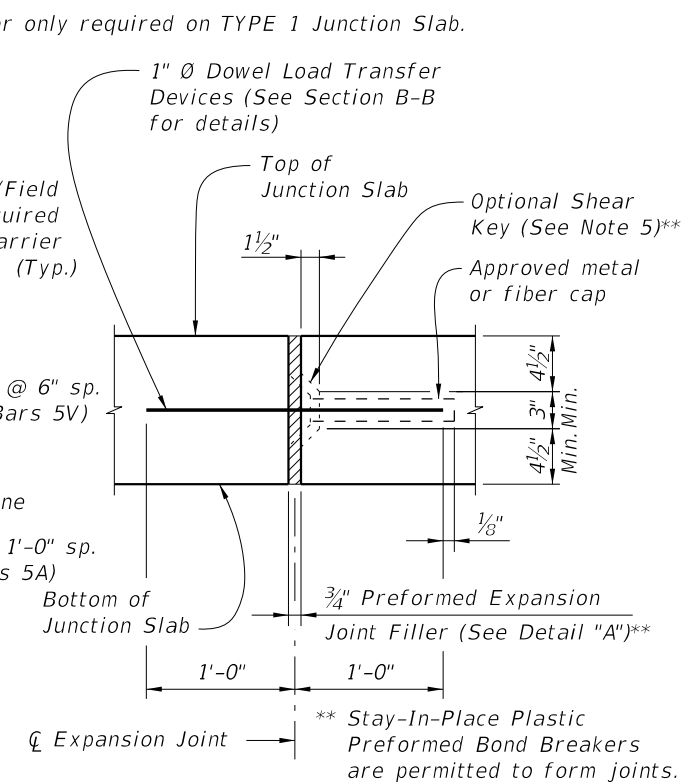

EXPANSION JOINT DETAIL**
 (Junction Slab expansion joints are required at 3/4" open joints in Concrete Barrier/Noise Wall)

NOTES

1. Work this Index with Index 521-510 - Concrete Barrier/Noise Wall (8'-0").
2. Concrete will be in accordance with Specification Section 346.
 - A. Use Class II concrete for slightly aggressive environments.
 - B. Class IV concrete for moderately or extremely aggressive environments.
3. Construct 3/4" Expansion Joints and face of coping plumb, and either perpendicular or radial to Gutter Line. Provide at 90'-0" maximum intervals as shown.
4. Dowel Load Transfer Devices will be hot-dip galvanized ASTM A36 smooth round bars or GFRP smooth round bars with a minimum shear strength of 22 ksi in accordance with ASTM D7617. Install Dowel Load Transfer Devices in accordance with Specification Section 350.
5. Shear Keys in Junction Slab are required when GFRP bars are used for Dowel Transfer Devices and are optional with steel dowel bars. Tongue Slope on Shear Key must be constant and between 5° to 45° from horizontal.
6. Construct 1/2" V-Grooves plumb and provide at 30'-0" maximum intervals as shown. Space V-Grooves equally between 3/4" Expansion Joints and/or Begin or End Junction Slab. V-Groove locations are to coincide with V-Groove locations in the Barrier/Noise Wall.
7. Provide Organic Felt bond breaker on top and Expanded Polystyrene (1/2" thick) on sides of retaining wall.
8. Shoulder or Roadway Pavement is required on top of the junction slab for its entire length on the traffic side of the Barrier/Noise Wall. See Section B-B for details.
9. Actual location & width vary depending on type of Retaining Wall used.
10. Field cut Bars 5A and 5B2 as required to maintain minimum cover for skewed Approach Slab.
11. Spacing shown is along the Gutter Line.
12. See Index 521-510 for Bars 5V and 2 ~ Bars 5S1. See Plans for Junction Slab width (TYPE).

CROSS REFERENCE:
 For Section B-B and Detail "A", see Sheet 2.

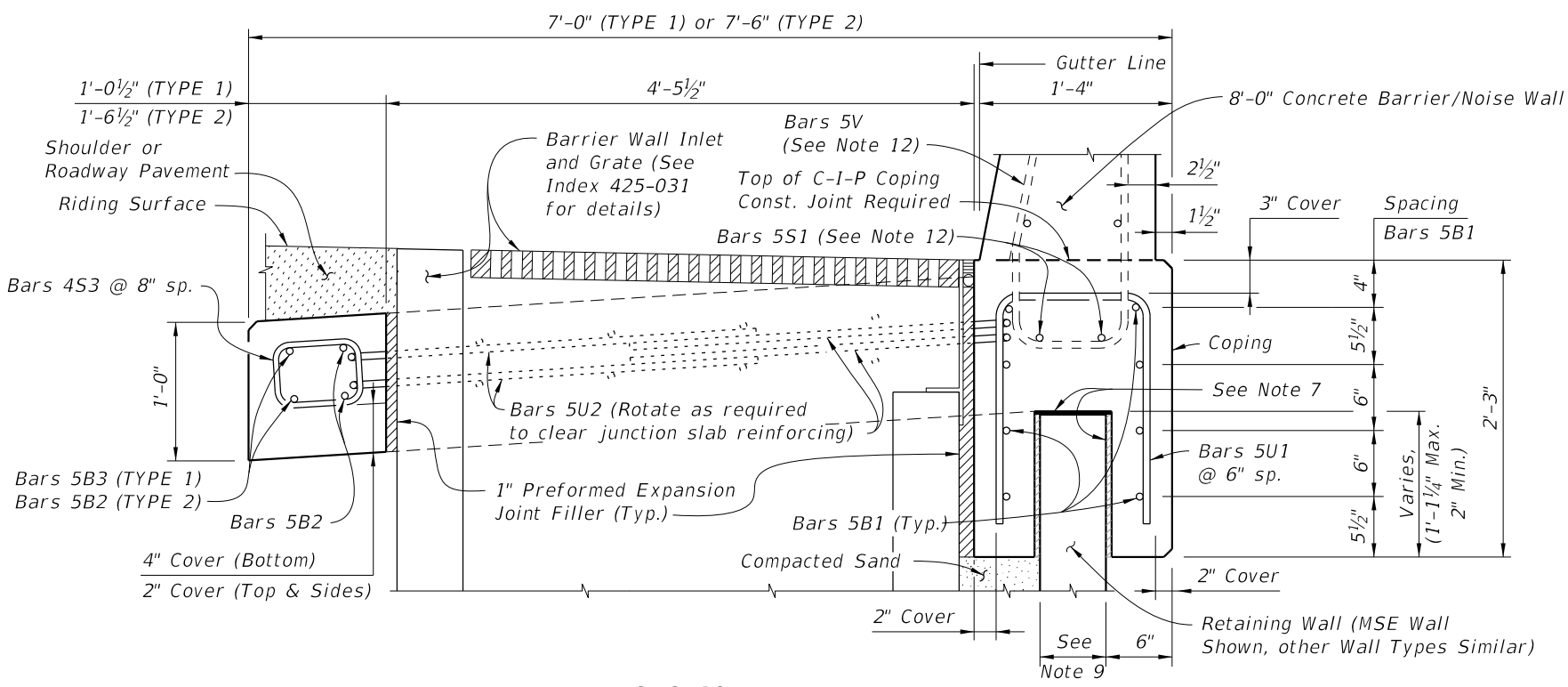

SECTION A-A
SECTION THRU JUNCTION SLAB, BARRIER WALL INLET AND RETAINING WALL
 (TYPE 1 Junction Slab Shown, TYPE 2 Similar)

10/20/2022 8:51:25 AM

LAST REVISION 11/01/20	REVISION	DESCRIPTION:		FY 2023-24 STANDARD PLANS	CONCRETE BARRIER/NOISE WALL JUNCTION SLAB	INDEX 521-512	SHEET 1 of 2
---------------------------	----------	--------------	--	------------------------------	--	------------------	-----------------

REINFORCING STEEL BENDING DIAGRAMS (8'-0" Concrete Barrier/Noise Wall) (TYPE 1 and 2)

BILL OF REINFORCING STEEL

MARK	SIZE	LENGTH	
		TYPE 1	TYPE 2
A	5	7'-10"	8'-10"
B1	5	AS REQD.	AS REQD.
B2	5	AS REQD.	AS REQD.
B3	5	10'-0"	N/A
F	5	4'-8"	5'-8"
L	5	4'-5"	4'-5"
S3	4	3'-1"	4'-0"
U1	5	4'-9"	4'-9"
U2	5	12'-10"	12'-10"
DOWEL	1" Ø Smooth Bar	2'-0"	2'-0"

REINFORCING STEEL NOTES:

1. All bar dimensions in the bending diagrams are out to out.
2. All reinforcing steel at the open joints will have a 2" minimum cover.
3. Lap splices for Bars 5B will be a minimum of 2'-2".
4. The Contractor may use Deformed WWR when approved by the Engineer. Deformed WWR must meet the requirements of Specification Section 931.

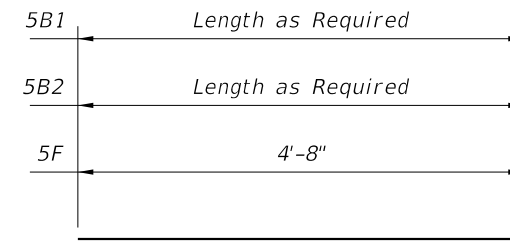
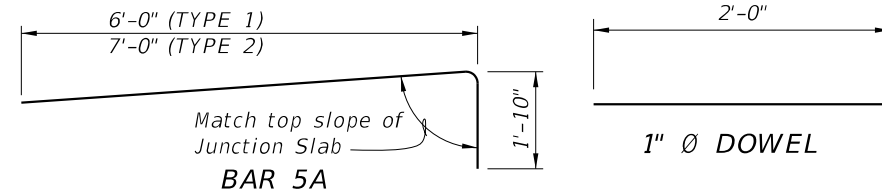

BARS 5B & 5F



BAR 5L

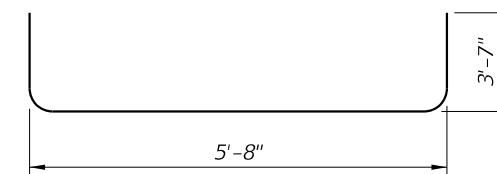

BAR 5U2

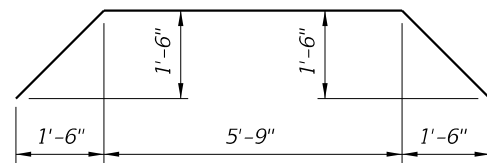

BAR 5B3 (TYPE 1 only)

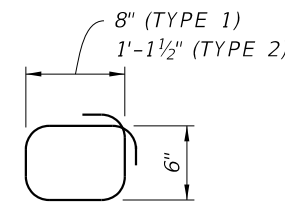

BAR 4S3

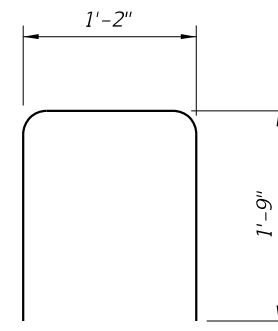

BAR 5U1

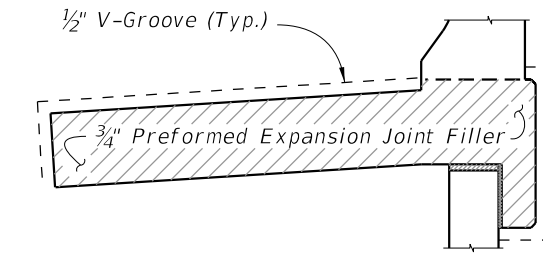

DETAIL "A"

(Showing Locations of 1/2" V-Grooves and 3/4" Preformed Expansion Joint Filler)

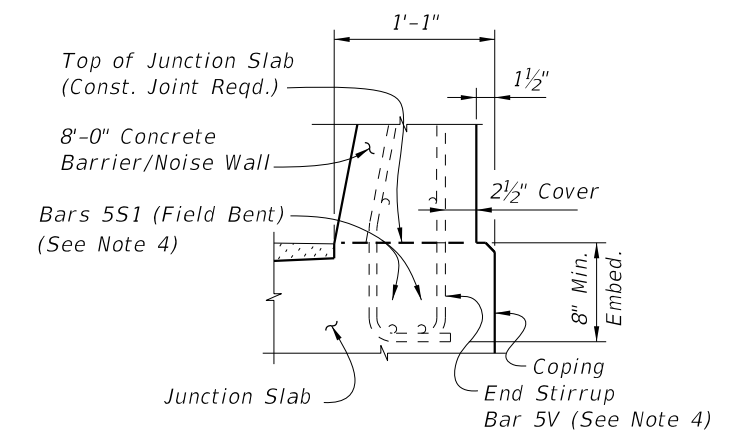

PARTIAL END VIEW OF RAILING END TRANSITION FOR GUARDRAIL ATTACHMENT (Showing Bars 5V and Bars 5B1)

NOTE: See Index 521-510, Detail "A" for details.

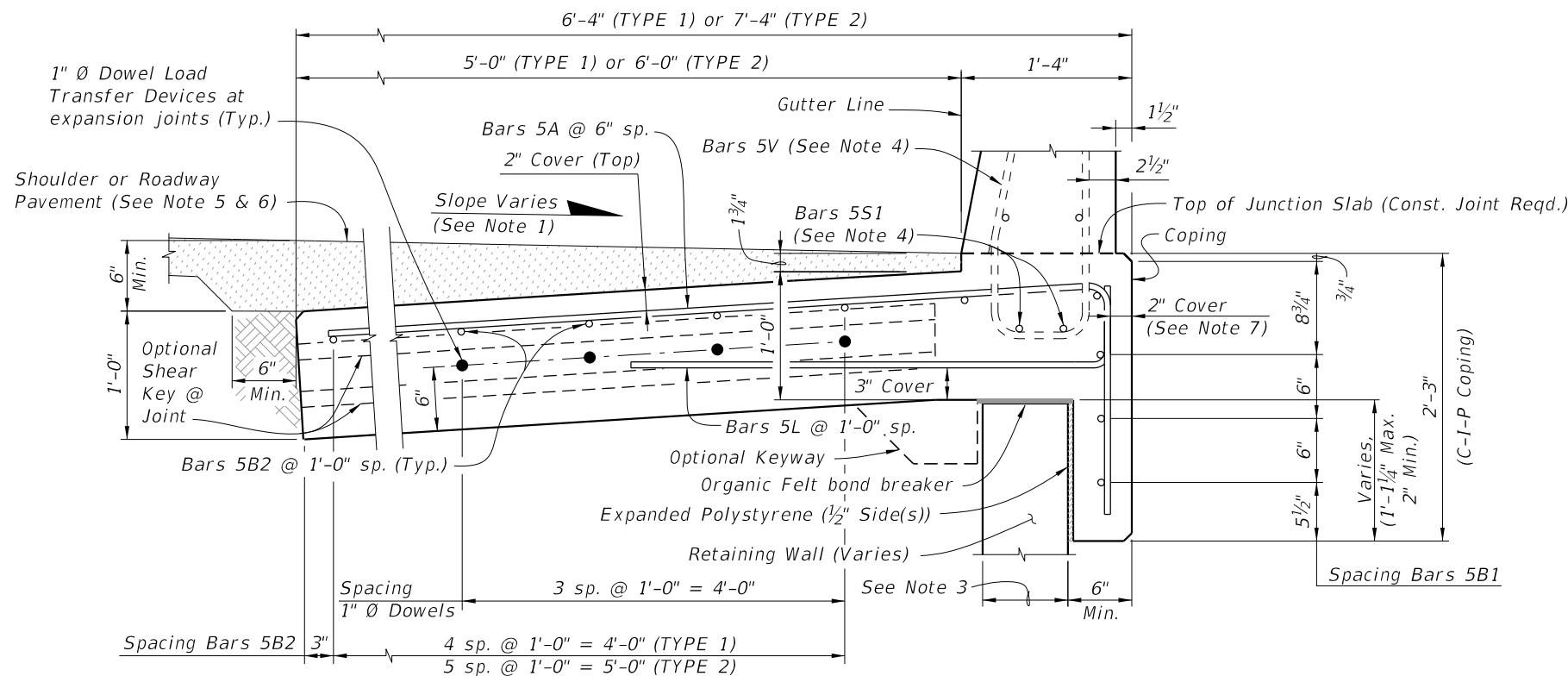

SECTION B-B
TYPICAL SECTION THRU JUNCTION SLAB AND RETAINING WALL
(8'-0" Concrete Barrier/Noise Wall)

ESTIMATED JUNCTION SLAB QUANTITIES

ITEM	UNIT	QUANTITY	
		TYPE 1	TYPE 2
Concrete (Junction Slab)	CY/FT	0.268	0.305
Reinforcing Steel (Typical)	LB/FT	31.72	34.85
Additional Reinf. @ Expansion Joint	LB	21.36	21.36

NOTES:

1. Match Cross Slope of Travel Lane or Shoulder.
2. Vary Junction Slab slope based on roadway cross slope to maintain a minimum 6" asphalt depth at the edge of the slab as shown.
3. Actual width varies depending on type of Retaining Wall used.
4. See Index 521-510 for Bars 5V and Bars 5S1.
5. For Rigid Pavement (Concrete), Junction Slab may be thickened to match finished grade. Vary the Junction Slab slope to maintain a minimum 1'-6" thickness at the inside edge of the slab.
6. See Roadway Plans for asphalt shoulder, roadway pavement and overbuild.
7. If slip forming is used, submit shop drawings for approval showing Expansion Joint support details and 2 1/2" side cover with adjusted Typical Section dimensions.
8. Bars 5L and 5C are grouped together and placed with every other Bar 5A.
9. Bar 5L to lap Bar 5C for minimum wall embedment. Minimum Lap splice length 2'-2".

CROSS REFERENCE:
For location of Section B-B, see Sheet 1.

10/20/2022 8:51:26 AM

LAST REVISION	DESCRIPTION:
11/01/22	



FY 2023-24
STANDARD PLANS

CONCRETE BARRIER/NOISE WALL
JUNCTION SLAB

INDEX
521-512

SHEET
2 of 2

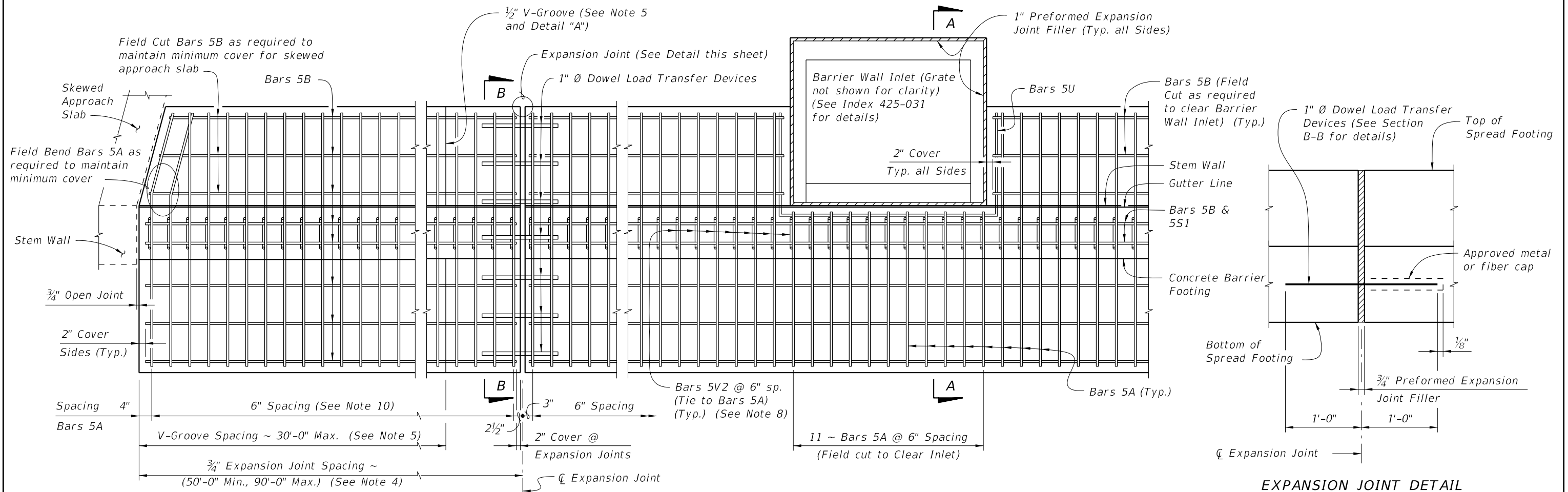

PLAN
SPREAD FOOTING ADJACENT TO SKEWED APPROACH SLAB AND WITH BARRIER WALL INLET

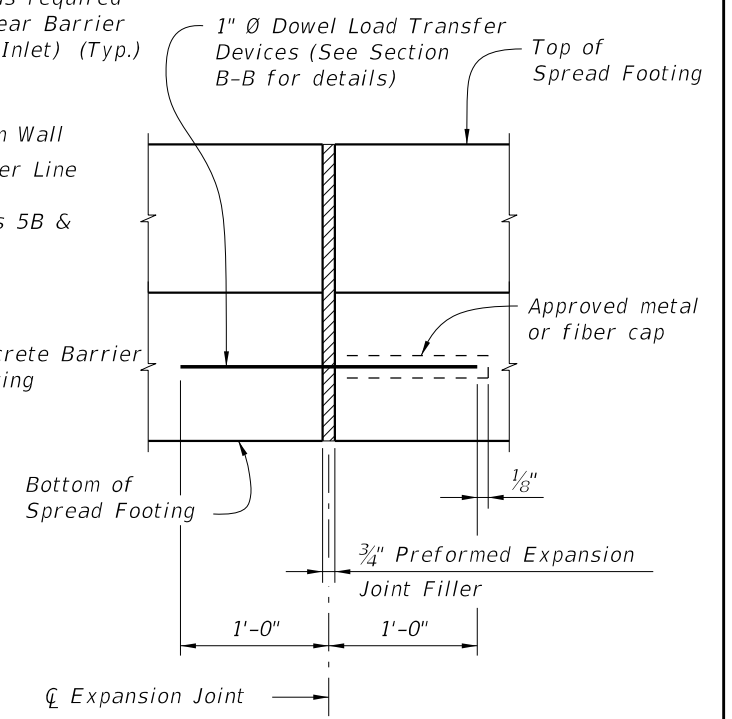

EXPANSION JOINT DETAIL
 (Spread Footing expansion joints are required at 3/4" open joints in Concrete Barrier/Noise Wall)

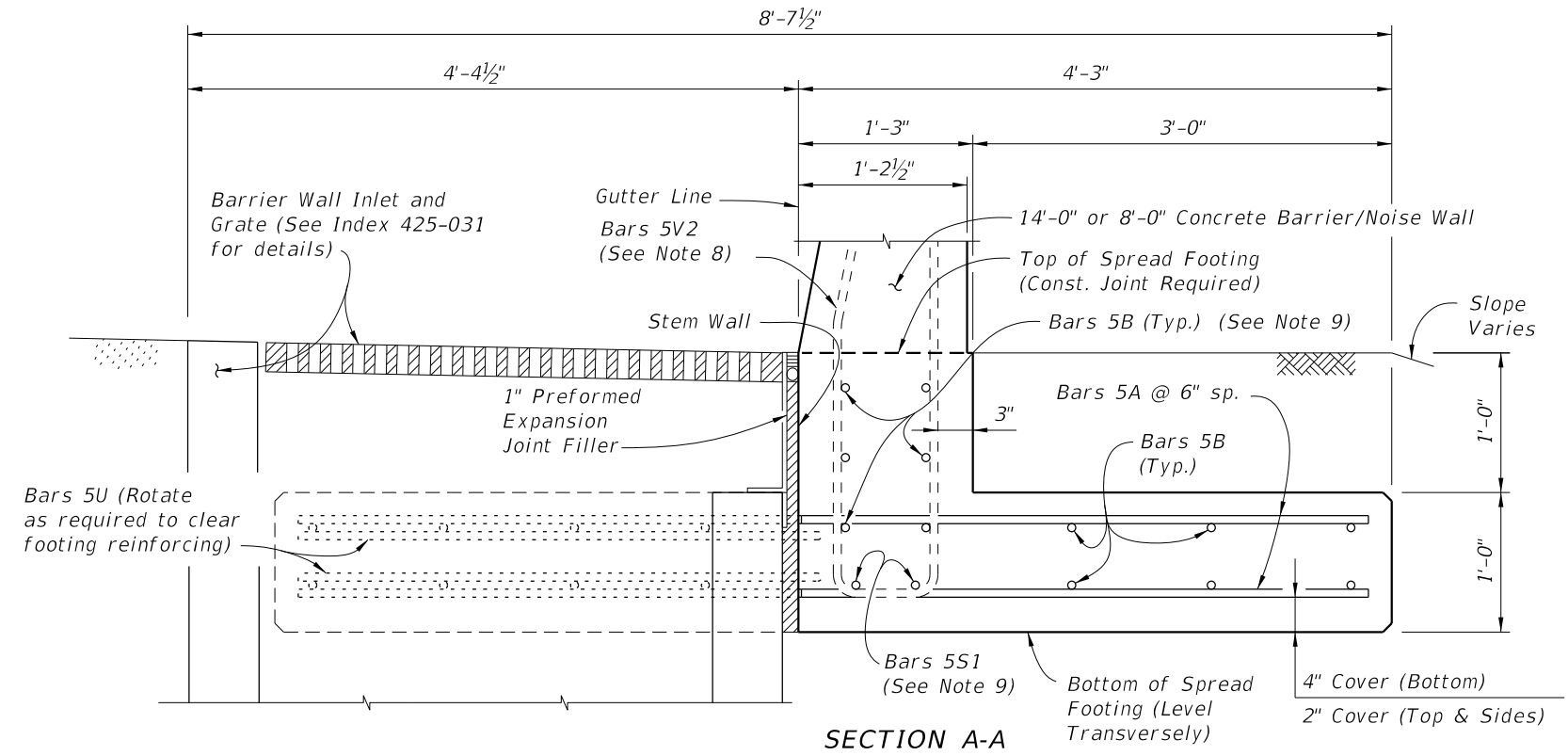

SECTION A-A
SECTION THRU SPREAD FOOTING AND BARRIER WALL INLET
 (Bars 5P, 5R and 5S1 in Concrete Barrier/Noise Wall not shown for clarity)

- NOTES**
- Construct the Spread Footing level transversely and plumb vertically; do not construct the spread footing perpendicular to the roadway surface.
 - Concrete will be in accordance with Specification Section 346.
 - A. Class II concrete for slightly aggressive environments.
 - B. Class IV concrete for moderately or extremely aggressive environments.
 - Dowel Load Transfer Devices will be ASTM A 36 smooth round bar and hot-dip galvanized in accordance with Specification Section 962. Install Dowel Load Transfer Devices in accordance with Specification Section 350.
 - Construct 3/4" Expansion Joints plumb and perpendicular or radial to Gutter Line. Provide at 90'-0" maximum intervals as shown.
 - Construct 1/2" V-Grooves plumb and provide at 30'-0" maximum intervals as shown. Space V-Grooves equally between 3/4" Expansion Joints and/or Begin or End Spread Footing. V-Groove locations are to coincide with V-Groove locations in the Barrier/Noise Wall.
 - Provide and install Preformed Expansion Joint Filler in accordance with Specification Section 932.
 - FILL REQUIREMENTS:** Shoulder or Roadway Pavement or Fill is required on top (1'-0" minimum depth) for the entire length of the spread footing on both sides of the Barrier/Noise Wall. See Section B-B for details.
 - See Index 521-510 for Bars 5V2.
 - Place 8 ~ Bars (6 ~ 5B1 & 2 ~ 5S1) inside Stirrup Bars 5V2 as shown. (2 ~ 5S1 Bars included in 521-510 or 521-511 quantities)
 - Spacing shown is along the Gutter Line.
 - Work this Index with one or both of the following:
 - a. Index 521-510 - Concrete Barrier/Noise Wall (8'-0").
 - b. Index 521-511 - Concrete Barrier/Noise Wall (14'-0").

CROSS REFERENCE:
 For Section B-B and Detail "A", see Sheet 2.

10/20/2022 8:51:27 AM

LAST REVISION 11/01/18	REVISION	DESCRIPTION:		FY 2023-24 STANDARD PLANS	CONCRETE BARRIER/NOISE WALL T-SHAPED SPREAD FOOTING	INDEX 521-513	SHEET 1 of 2
---------------------------	----------	--------------	--	---	---	-------------------------	------------------------

REINFORCING STEEL BENDING DIAGRAMS

BILL OF REINFORCING STEEL

MARK	SIZE	LENGTH
A	5	6'-8"
B	5	AS REQD.
U	5	11'-0"
DOWEL	1" Ø Smooth Bar	2'-0"

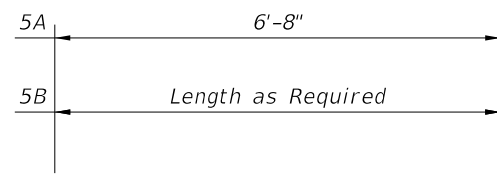

BARS 5A & 5B

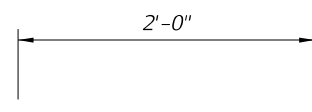

1" Ø DOWEL

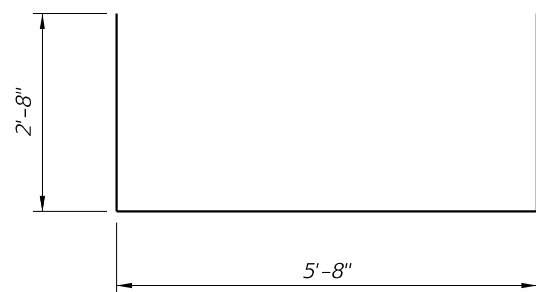

BAR 5U

REINFORCING STEEL NOTES:

1. All bar dimensions in the bending diagrams are out to out.
2. All reinforcing steel at the open joints will have a 2" minimum cover.
3. Lap splices for Bars 5B will be a minimum of 2'-2".
4. The Contractor may use Welded Wire Reinforcement (WWR) when approved by the Engineer. WWR must consist of Deformed wire meeting the requirements of Specification Section 931.

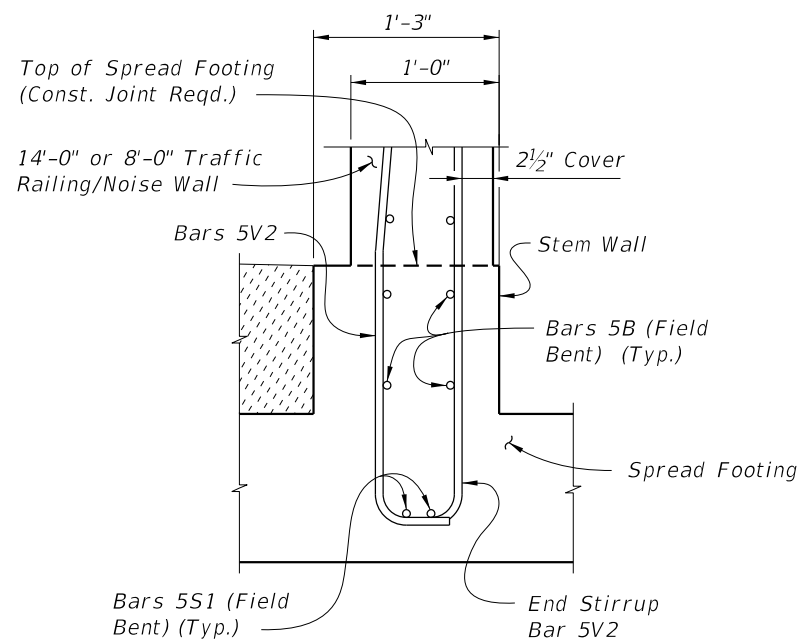

PARTIAL END VIEW OF RAILING END TRANSITION FOR GUARDRAIL ATTACHMENT (Showing Bars 5V2, and Bars 5B inside of Stirrup Bars 5V2)

NOTE: See Index 521-510, Detail "A" for details.

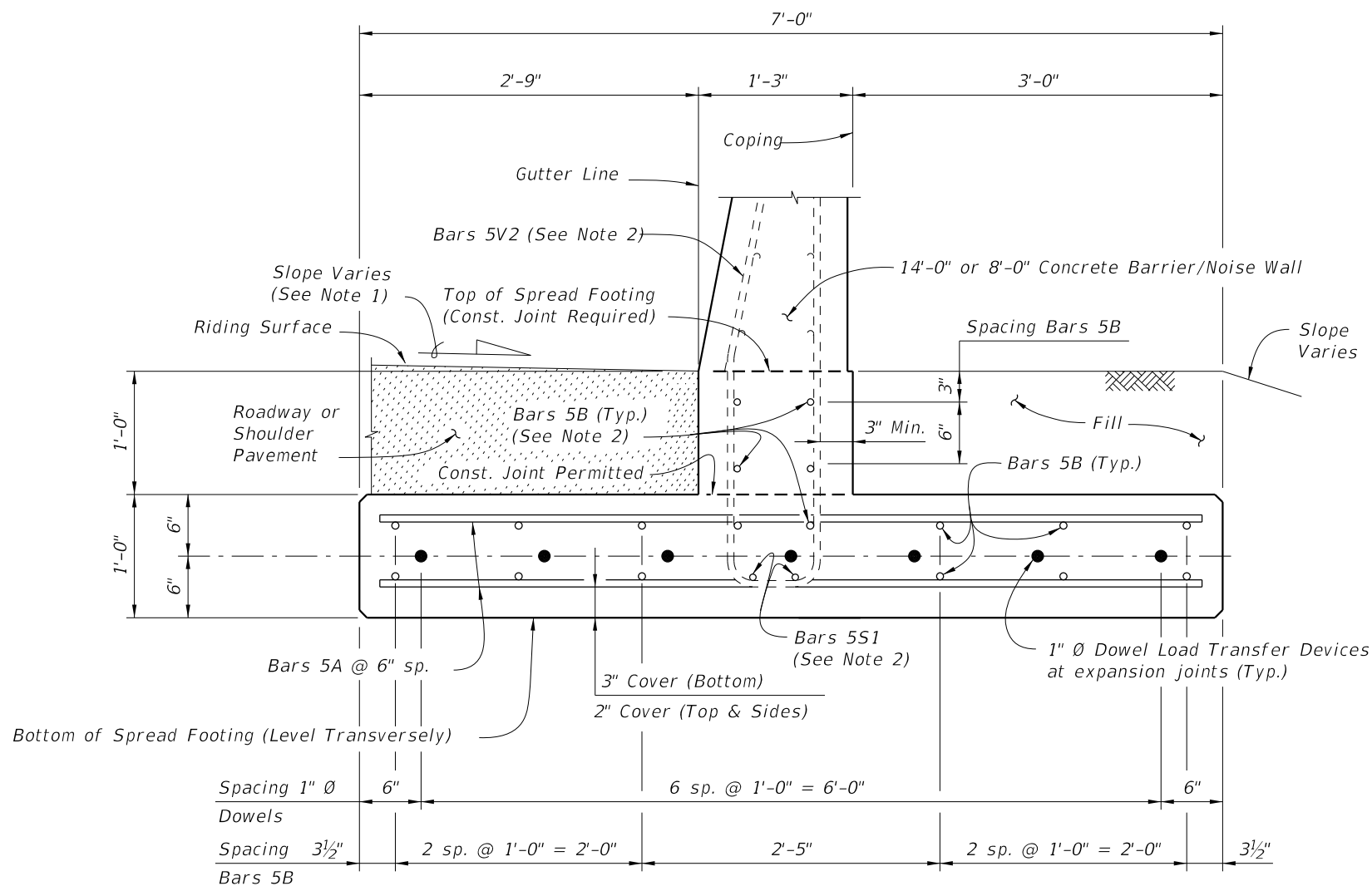

**SECTION B-B
TYPICAL SECTION THRU SPREAD FOOTING
(Bars 5R and 5S1 in Concrete Barrier/Noise Wall not shown for clarity)**

NOTES:

1. Match Cross Slope of Travel Lane or Shoulder.
2. See Sheet 1, Notes 8 & 9.

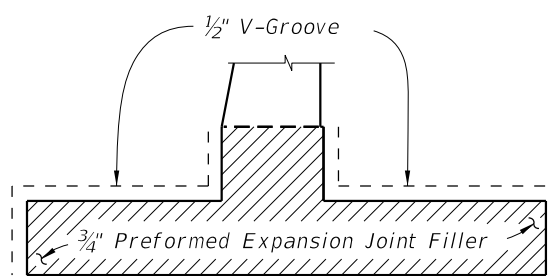

DETAIL "A"

(Showing Locations of 1/2" V-Grooves and 3/4" Preformed Expansion Joint Filler)

ESTIMATED T-SHAPED SPREAD FOOTING QUANTITIES

ITEM	UNIT	QUANTITY
Concrete (Footing)	CY/FT	0.312
Reinforcing Steel (Typical)	LB/FT	25.90
Additional Reinf. @ Expansion Joint	LB	37.38

Note: The reinforcing steel quantity includes the difference between Index 521-510 or 521-511 and Bars 5V shown. Bars 5S1 are included in Index 521-510 or 521-511 quantities.

CROSS REFERENCE:
For location of Section B-B, see Sheet 1.

10/20/2022 8:51:28 AM

LAST REVISION	DESCRIPTION:
11/01/17	



**FY 2023-24
STANDARD PLANS**

**CONCRETE BARRIER/NOISE WALL
T-SHAPED SPREAD FOOTING**

INDEX
521-513

SHEET
2 of 2

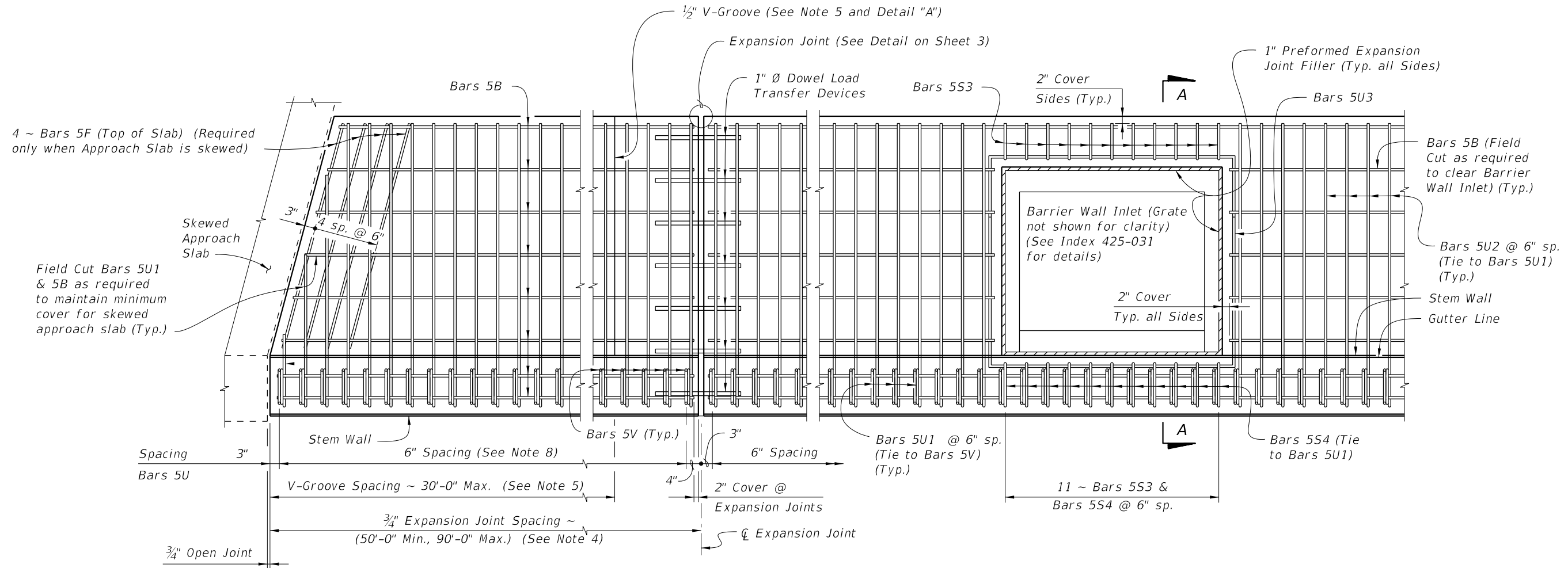

PLAN - OPTION B
SPREAD FOOTING ADJACENT TO SKEWED APPROACH SLAB AND WITH BARRIER WALL INLET
(Option A Similar) (Bars 5I Not Shown)

NOTES

1. Construct the Spread Footing level transversely; do not construct the spread footing perpendicular to the roadway surface.
2. Concrete will be in accordance with Specification Section 346.
 - A. Class II concrete for slightly aggressive environments.
 - B. Class IV concrete for moderately or extremely aggressive environments.
3. Dowel Load Transfer Devices will be ASTM A 36 smooth round bar and hot-dip galvanized in accordance with Specification Section 962. Install Dowel Load Transfer Devices in accordance with Specification Section 350.
4. Construct $\frac{3}{4}$ " Expansion Joints plumb and perpendicular or radial to Gutter Line. Provide at 90'-0" maximum intervals as shown.
5. Construct $\frac{1}{2}$ " V-Grooves plumb and provide at 30'-0" maximum intervals as shown. Space V-Grooves equally between $\frac{3}{4}$ " Expansion Joints and/or Begin or End Spread Footing. V-Groove locations are to coincide with V-Groove locations in the Concrete Barrier/Noise Wall.
6. Provide and install Preformed Expansion Joint Filler in accordance with Specification Section 932.
7. Shoulder or Roadway Pavement and Fill is required on the traffic side of the spread footing for a distance of 4'-0" and the full length of the spread footing (3'-0" minimum depth) on the backside of the spread footing for Option A. Fill is required for a distance of 4'-0" on the backside of the spread footing and the full length of the spread footing (3'-0" minimum depth) on the traffic side of the spread footing for Option B. See Typical Sections on Sheets 2 and 3 for details.
8. Spacing shown is along the Gutter Line.
9. Work this Index with one or both of the following:
 - a. Index 521-510 - Concrete Barrier/Noise Wall (8'-0").
 - b. Index 521-511 - Concrete Barrier/Noise Wall (14'-0").

CROSS REFERENCE:
 For Detail "A", see Sheet 3.
 For Section A-A and Estimated Quantities, see Sheet 4.

10/20/2022 8:51:30 AM

LAST REVISION 11/01/18	REVISION DESCRIPTION:	 FY 2023-24 STANDARD PLANS	CONCRETE BARRIER/NOISE WALL L-SHAPED SPREAD FOOTING	INDEX 521-514	SHEET 1 of 4
---------------------------	-----------------------	---	--	-------------------------	------------------------

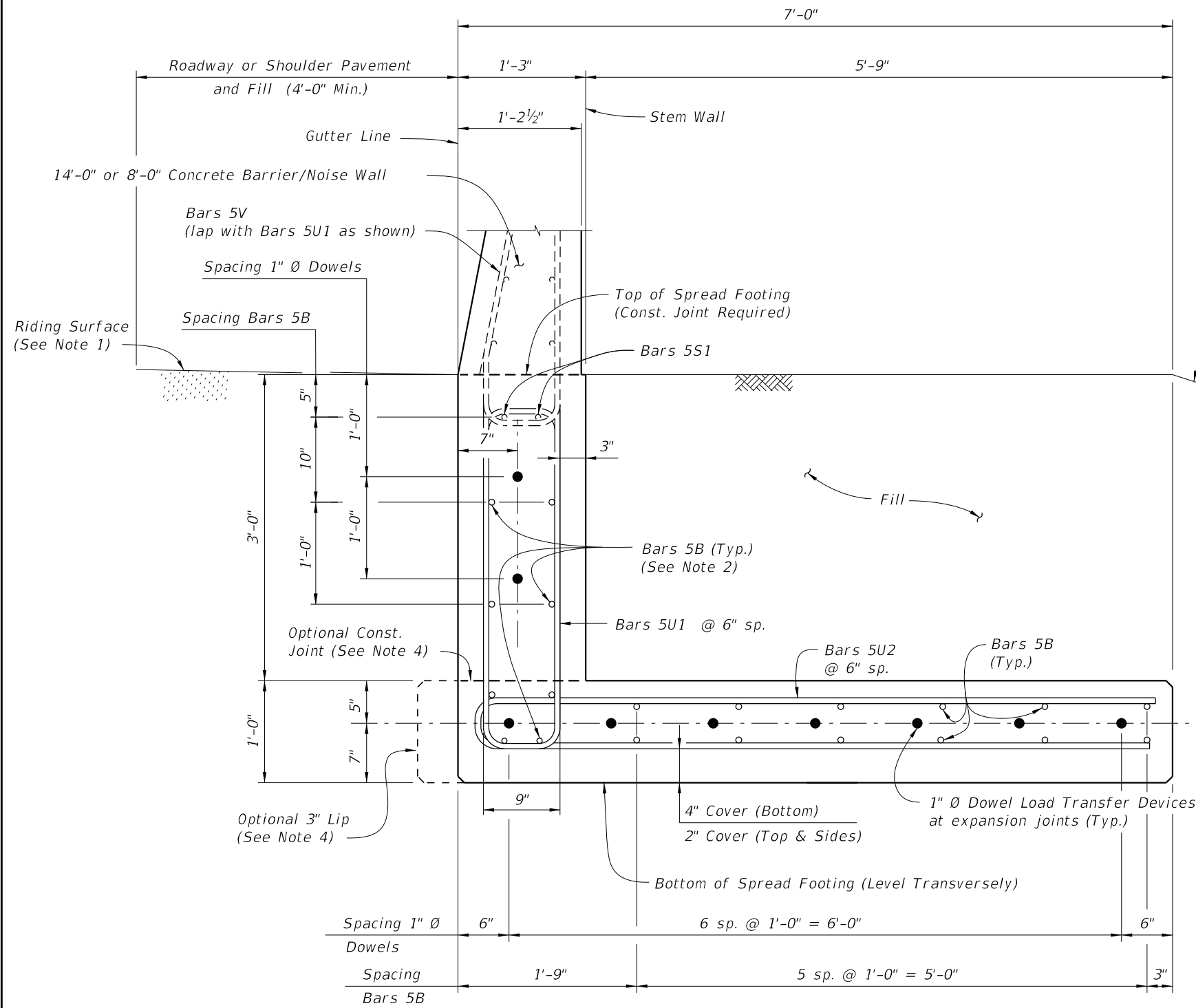

TYPICAL SECTION THRU SPREAD FOOTING - OPTION A
(Bars 5R and 5S1 in Concrete Barrier/Noise Wall not shown for clarity)

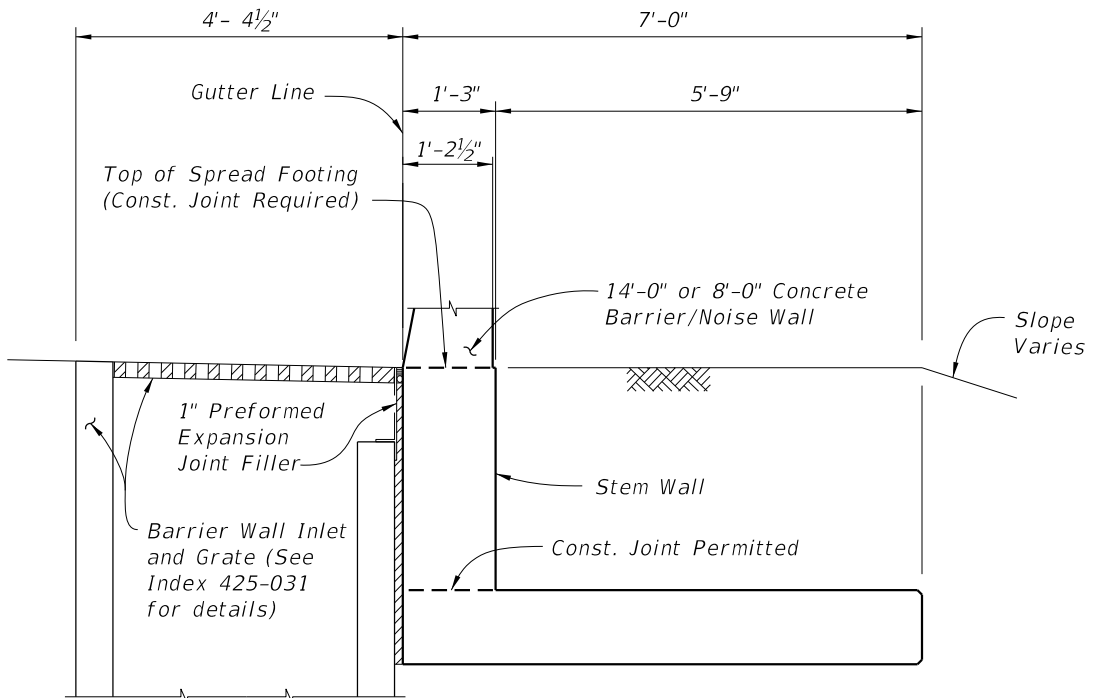

TYPICAL SECTION THRU SPREAD FOOTING AND BARRIER WALL INLET - OPTION A
(Reinforcing Steel not shown for clarity (See Note 3))

- NOTES:
1. Match Cross Slope of Travel Lane or Shoulder.
 2. Place 10 ~ Bars (8 ~ Bars 5B and 2 ~ Bars 5S1) inside Bars 5U1 as shown, (2 ~ 5S1 Bars are included in 521-510 or 521-511 quantities)
 3. For Reinforcing Steel spacing, see Typical Section Thru Spread Footing - Option A this Sheet.
 4. Provide 3" lip when optional construction joint is used.

10/20/2022 8:51:31 AM

LAST REVISION 11/01/17	REVISION	DESCRIPTION:		FY 2023-24 STANDARD PLANS	CONCRETE BARRIER/NOISE WALL L-SHAPED SPREAD FOOTING	INDEX 521-514	SHEET 2 of 4
---------------------------	----------	--------------	--	------------------------------	--	------------------	-----------------

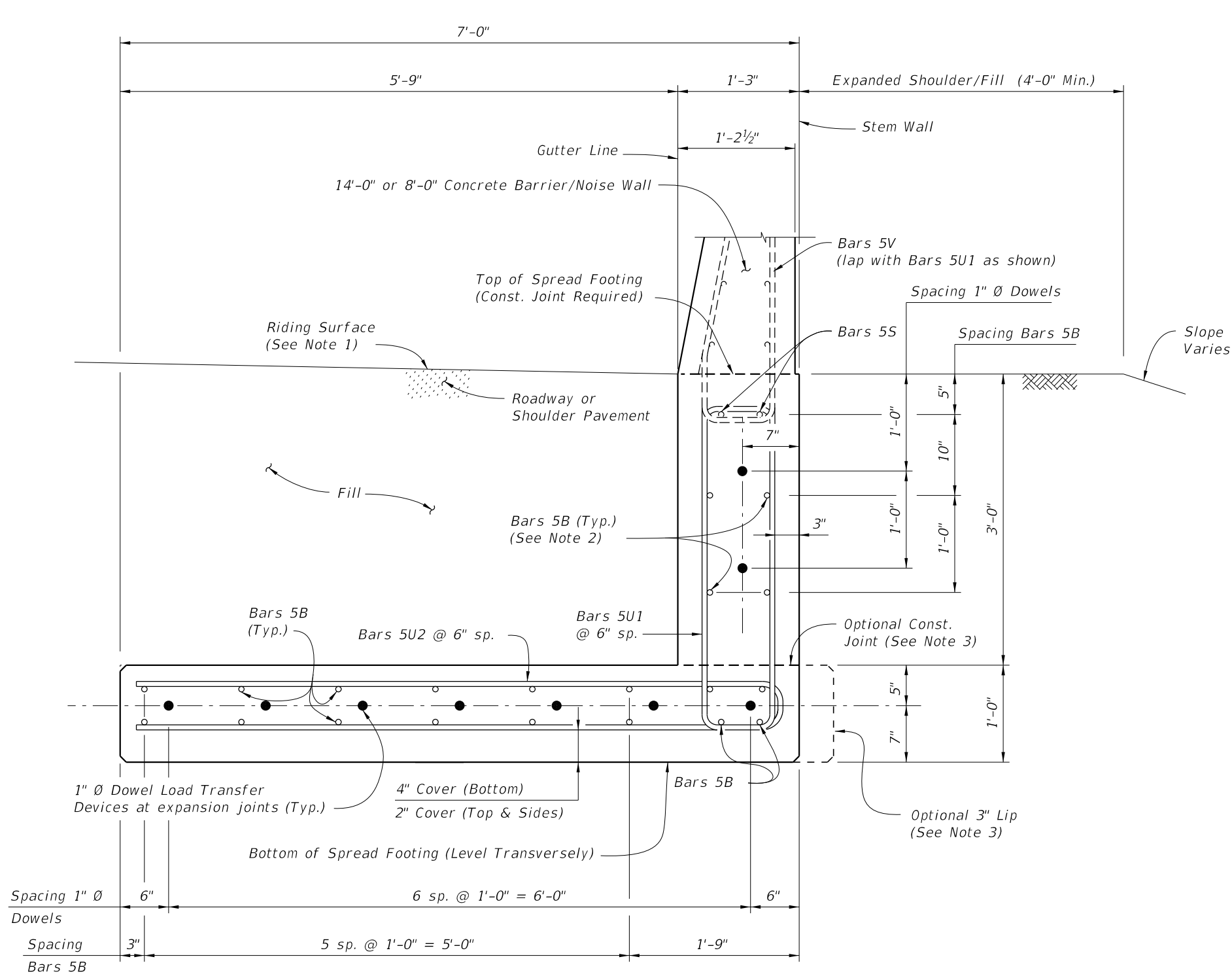

TYPICAL SECTION THRU SPREAD FOOTING - OPTION B
 (Bars 5P, 5R and 5S1 in Concrete Barrier/Noise Wall not shown for clarity)

NOTES:

1. Match Cross Slope of Travel Lane or Shoulder.
2. Place 10 ~ Bars (8 ~ Bars 5B and 2 ~ Bars 5S1) inside Bars 5U1 as shown.
3. Provide 3" lip when optional construction joint is used.

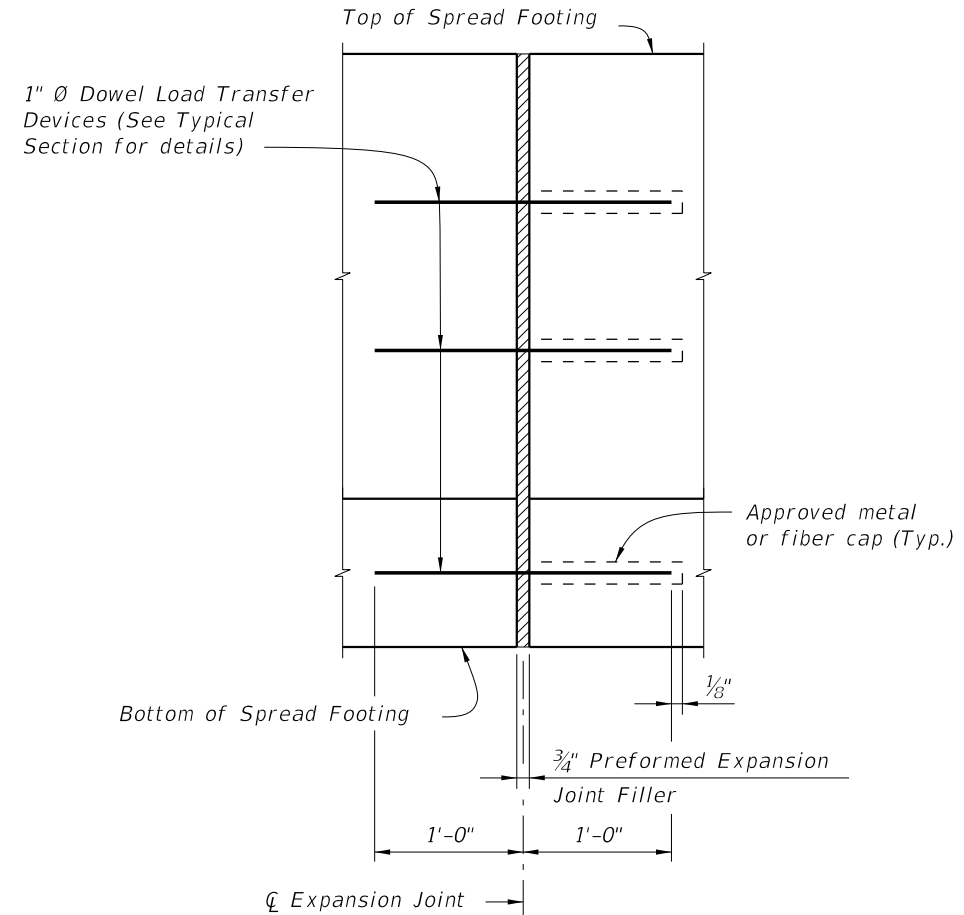

EXPANSION JOINT DETAIL
 (Spread Footing expansion joints are required at 3/4" open joints in Concrete Barrier/Noise Wall)

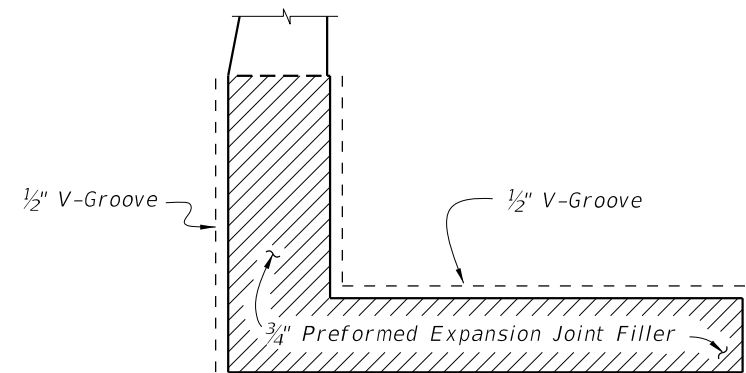

DETAIL "A"
 (Option A Shown, Option B Similar)

(Showing Locations of 1/2" V-Grooves and 3/4" Preformed Expansion Joint Filler)

10/20/2022 8:51:32 AM

LAST REVISION 11/01/17	REVISION	DESCRIPTION:		FY 2023-24 STANDARD PLANS	CONCRETE BARRIER/NOISE WALL L-SHAPED SPREAD FOOTING	INDEX	SHEET
						521-514	3 of 4

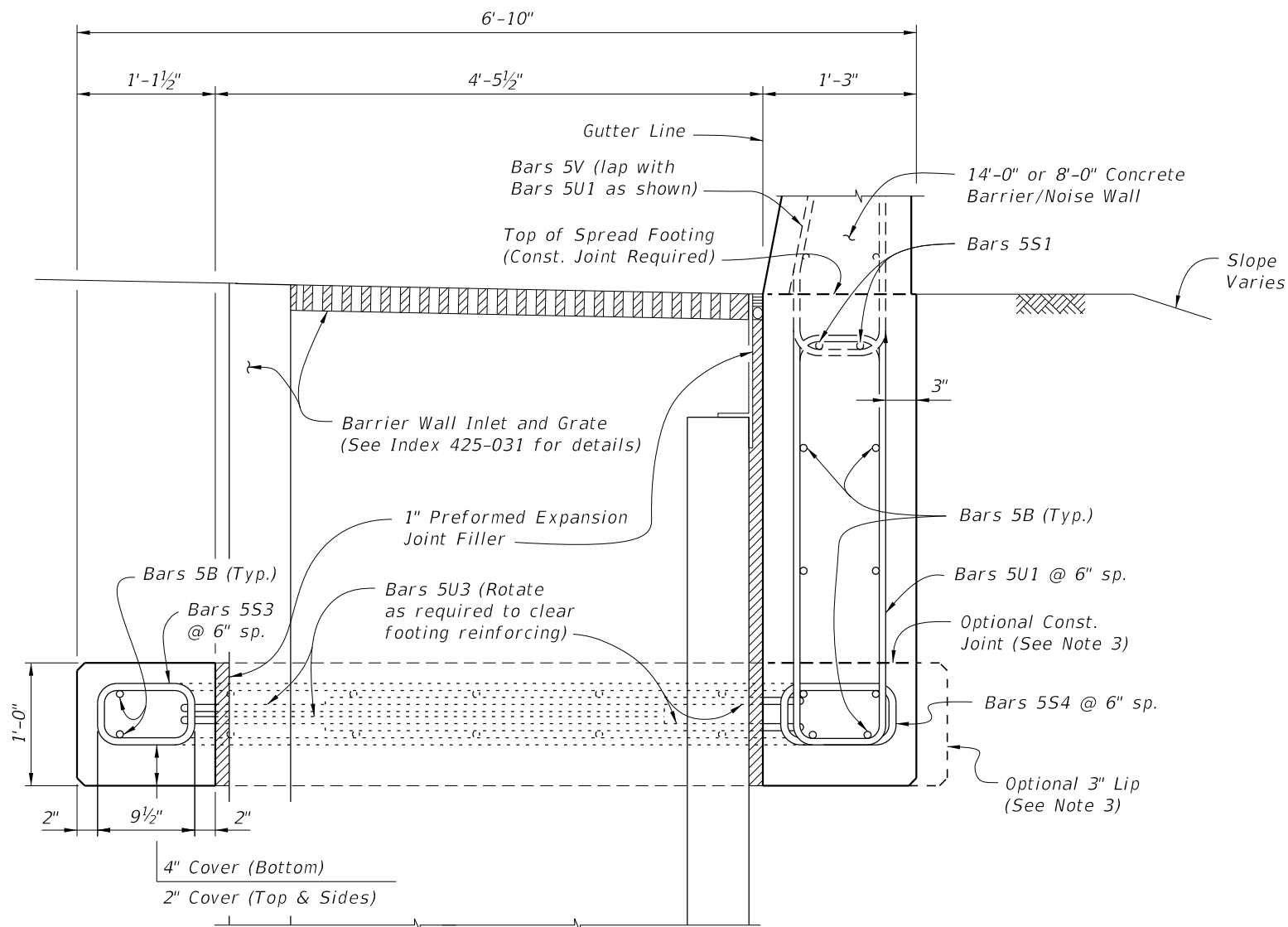

SECTION A-A
TYPICAL SECTION THRU SPREAD FOOTING AND BARRIER WALL INLET - OPTION B
 (Bars 5P, 5R and 5S1 in Concrete Barrier/Noise Wall not shown for clarity)

NOTES:

1. Place 8 ~ Bars 5B and 2 Bars 5S1 inside Bars 5U1 as shown.
2. For Reinforcing Steel spacing, see Typical Section Thru Spread Footing - Option B on Sheet 3.
3. Provide 3" lip when optional construction joint is used.

ESTIMATED L-SHAPED SPREAD FOOTING QUANTITIES

ITEM	UNIT	QUANTITY
Concrete (Footing)	CY/FT	0.398
Reinforcing Steel (Typical) *	LB/FT	68.84
Additional Reinf. @ Expansion Joint	LB	48.06

* Bars 5V and 5S1 are included in Index 521-510 or 521-511 quantities.

CROSS REFERENCE:
 For location of Section A-A, see Sheet 1.

REINFORCING STEEL BENDING DIAGRAMS

BILL OF REINFORCING STEEL

MARK	SIZE	LENGTH
B	5	AS REQD.
F	5	5'-6"
S3	5	3'-7"
S4	5	3'-10"
U1	5	9'-2"
U2	5	13'-10"
U3	5	12'-10"
DOWEL	1" Ø Smooth Bar	2'-0"

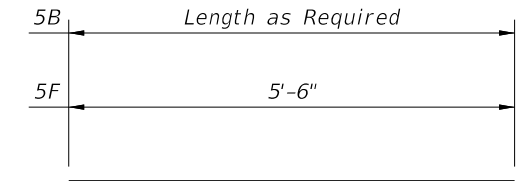

BARS 5B & 5F

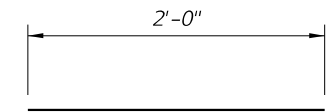

1" Ø DOWEL

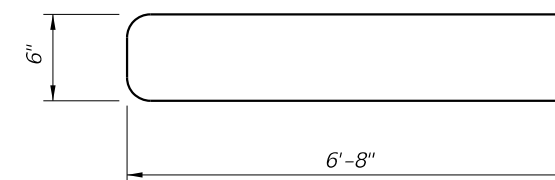

BAR 5U2

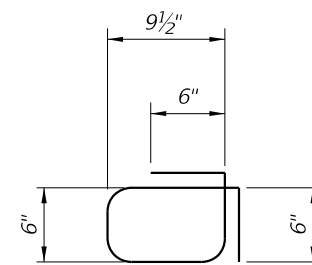

BAR 5S3

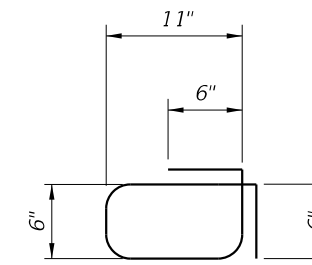

BAR 5S4

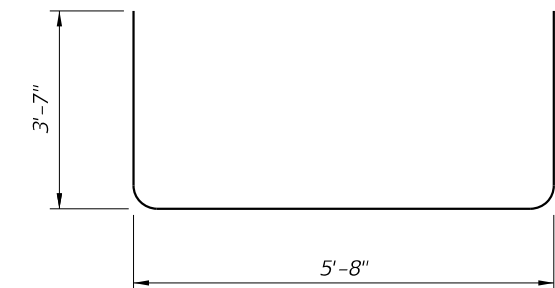

BAR 5U3

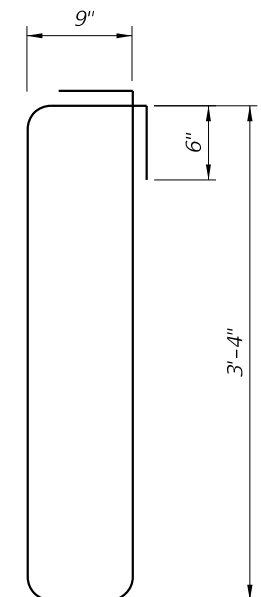

BAR 5U1

REINFORCING STEEL NOTES:

1. All bar dimensions in the bending diagrams are out to out.
2. All reinforcing steel at the open joints will have a 2" minimum cover.
3. Lap splices for Bars 5B will be a minimum of 2'-2".
4. Lap splices Bars 5T and 5V with 5U1 will be a minimum of 2'-2".
5. The Contractor may use Welded Wire Reinforcement (WWR) when approved by the Engineer. WWR must consist of Deformed wire meeting the requirements of Specification Section 931.

10/20/2022 8:51:32 AM

REINFORCING STEEL BENDING DIAGRAMS

BILL OF REINFORCING STEEL

MARK	SIZE	LENGTH
B	5	AS REQD.
T	5	13'-7"
DOWEL	1" Ø Smooth Bar	2'-0"

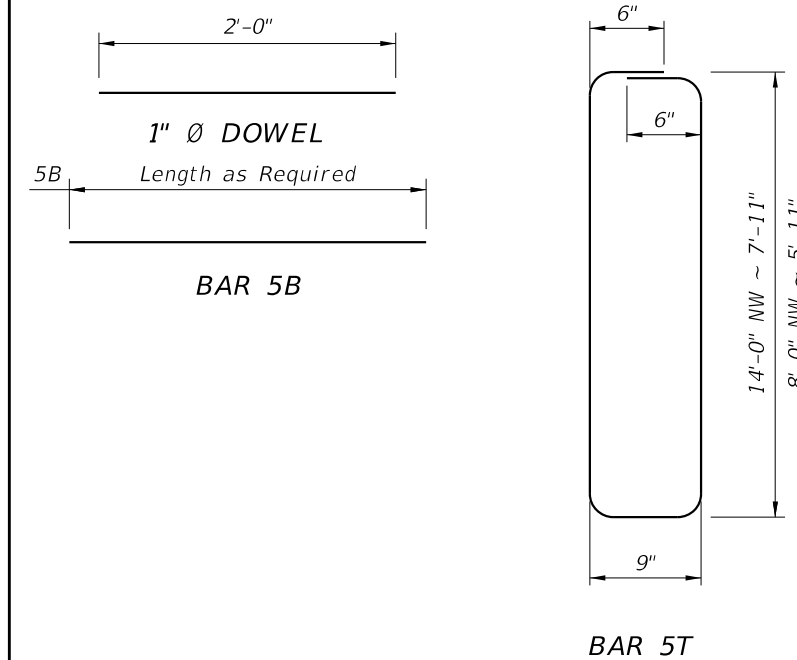

REINFORCING STEEL NOTES:

- All bar dimensions in the bending diagrams are out to out.
- All reinforcing steel at the open joints will have a 2" minimum cover.
- Lap splices for Bars 5B will be a minimum of 2'-2".
- The Contractor may use Deformed Welded Wire Reinforcement (WWR) meeting the requirements of Specification Section 931 when approved by the Engineer.

NOTES

- Construct the Trench Footing plumb, do not construct the Trench Footing perpendicular to the roadway surface.
- Concrete will be in accordance with Specification Section 346.
 - A. Class II concrete for slightly aggressive environments.
 - B. Class VI concrete for moderately or extremely aggressive environments.
- Dowel Load Transfer Devices will be hot-dip galvanized ASTM A36 smooth round bar or GFRP smooth round bars with a minimum shear strength of 22 ksi in accordance with ASTM D7617. Install Dowel Load Transfer Devices in accordance with Specification Section 350.
- Shear Keys in footing are required when GFRP bars are used for Dowel Transfer Devices and are optional with steel dowel bars. Tongue Slope on Shear Key must be constant and between 5° to 45° from the transverse vertical plane.
- Construct 3/4" Expansion Joints plumb and perpendicular or radial to Gutter Line. Provide at 90'-0" maximum intervals as shown.
- Construct 1/2" V-Grooves plumb and provide at 30'-0" maximum intervals as shown. Space V-Grooves equally between 3/4" Expansion Joints and/or Begin or End Trench Footing. V-Groove locations are to coincide with V-Groove locations in the Barrier/Noise Wall.
- Fill is required a distance of 4'-0" on both sides for the entire depth of the trench footing. See Typical Section for details.
- Match Cross Slope of travel lane or shoulder.
- Spacing shown is along the Gutter Line.
- Work this Index with one or both of the following:
 - a. Index 521-510 - Concrete Barrier/Noise Wall (8'-0").
 - b. Index 521-511 - Concrete Barrier/Noise Wall (14'-0").

LEGEND: NW = Concrete Barrier
Barrier/Noise Wall

ESTIMATED TRENCH FOOTING QUANTITIES

ITEM	UNIT	QUANTITY	
		8'-0" NW	14'-0" NW
Concrete (Footing)	CY/FT	0.341	0.446
Reinforcing Steel (Typical) *	LB/FT	38.76	49.19
Additional Reinf. @ Expansion Joint	LB	21.36	21.36

* Bars 5V and 5S1 are included in Index 521-510 or 521-511 quantities.

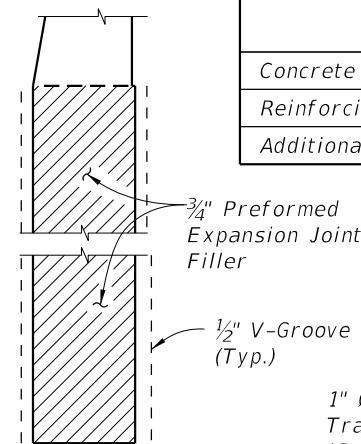

DETAIL "A"
(Showing Locations of 1/2" V-Grooves and 3/4" Preformed Expansion Joint Filler)

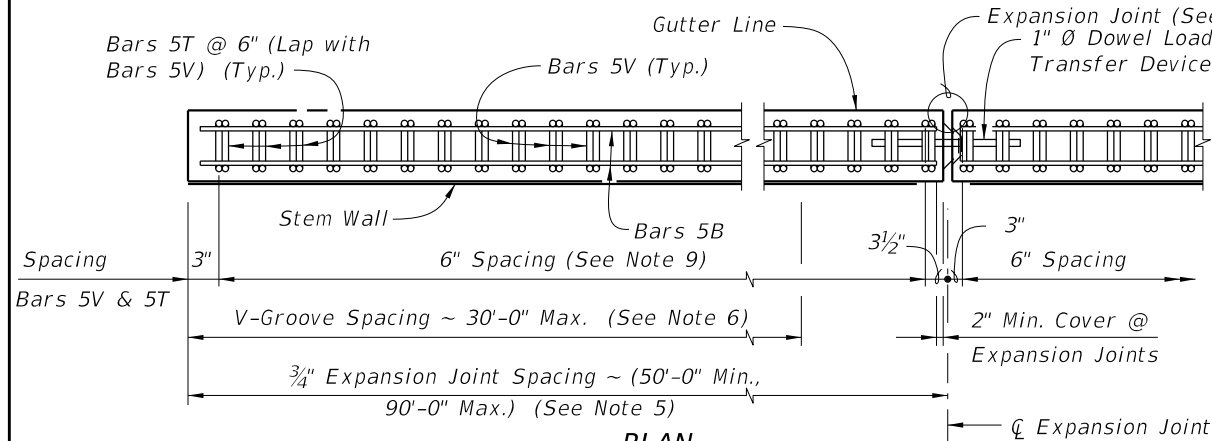

PLAN
(Bars 5S1 Not Shown)

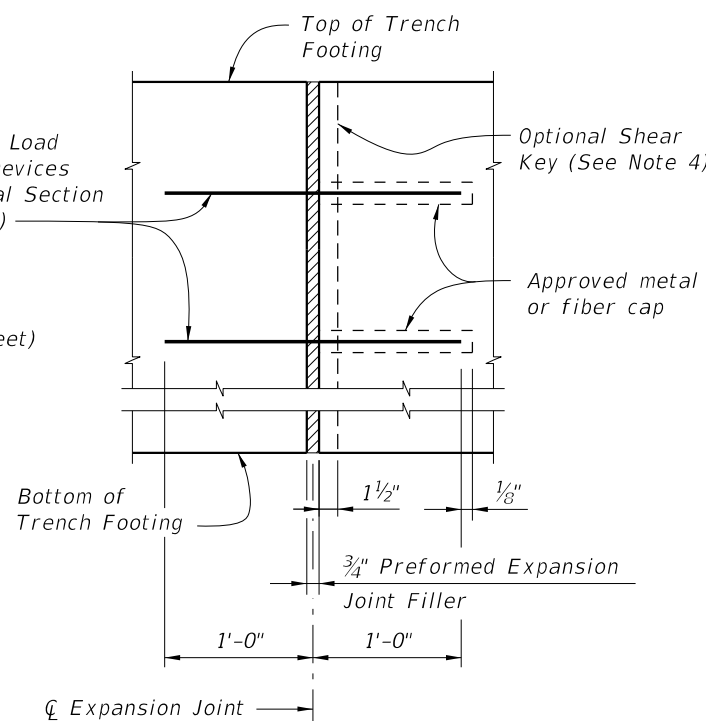

EXPANSION JOINT DETAIL

(Trench Footing expansion joints are required at 3/4" open joints in Concrete Barrier/Noise Wall)

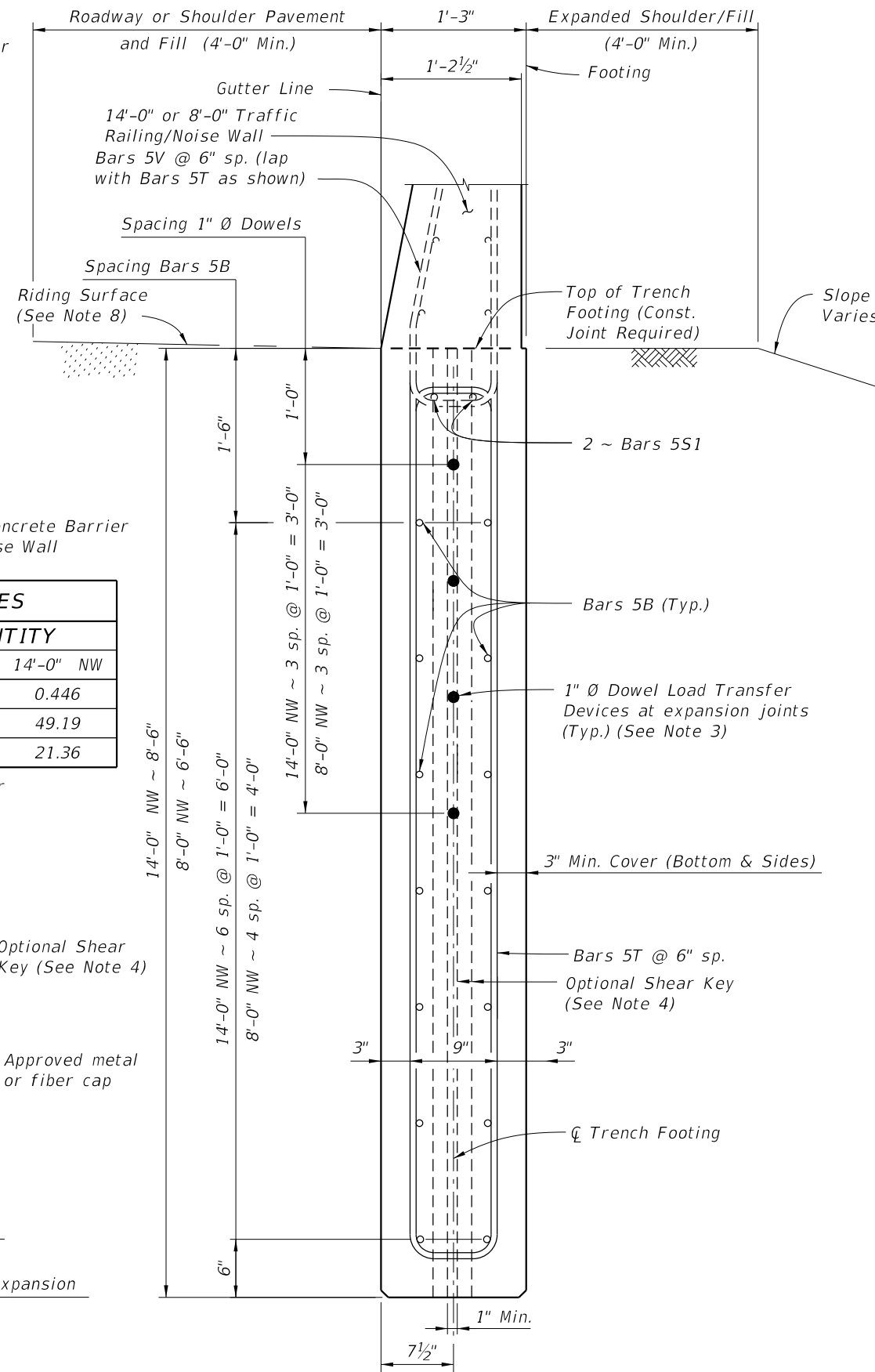

TYPICAL SECTION THRU TRENCH FOOTING

(Bars 5R and 5S1 in Concrete Barrier/Noise Wall not shown for clarity)

10/20/2022 8:51:34 AM

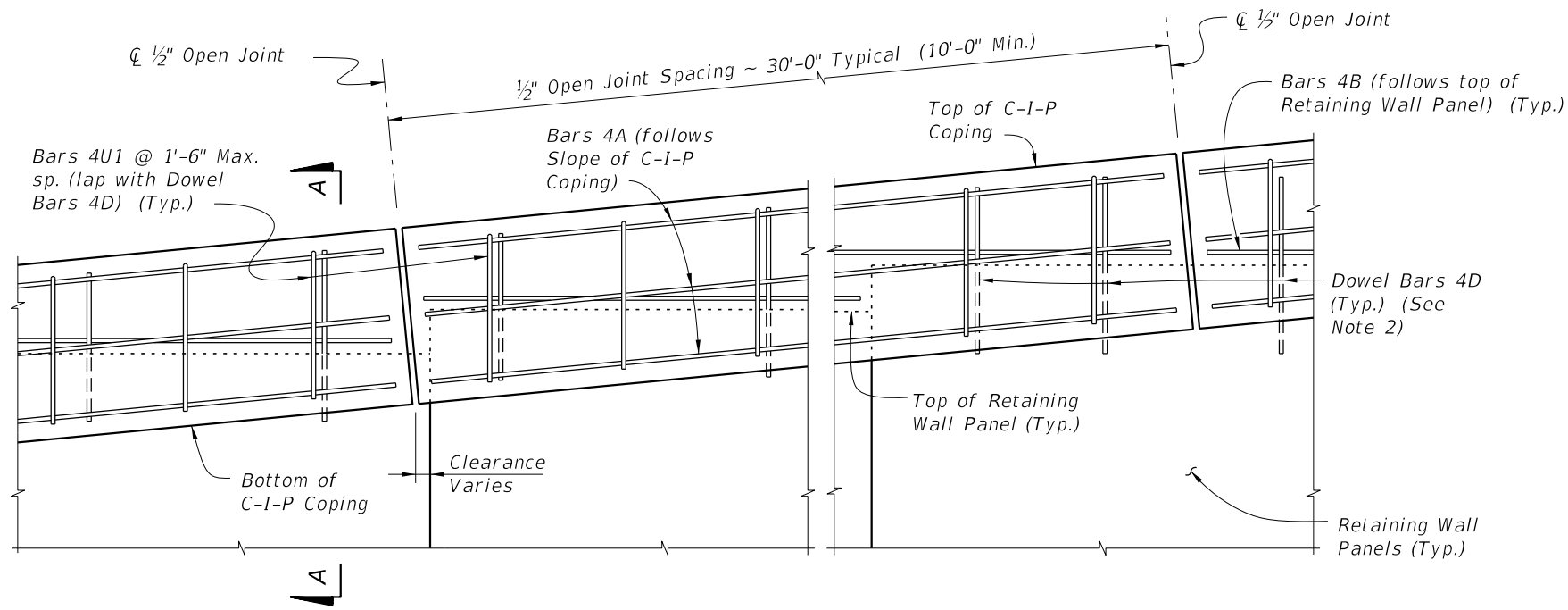

C-I-P COPING - PARTIAL ELEVATION VIEW

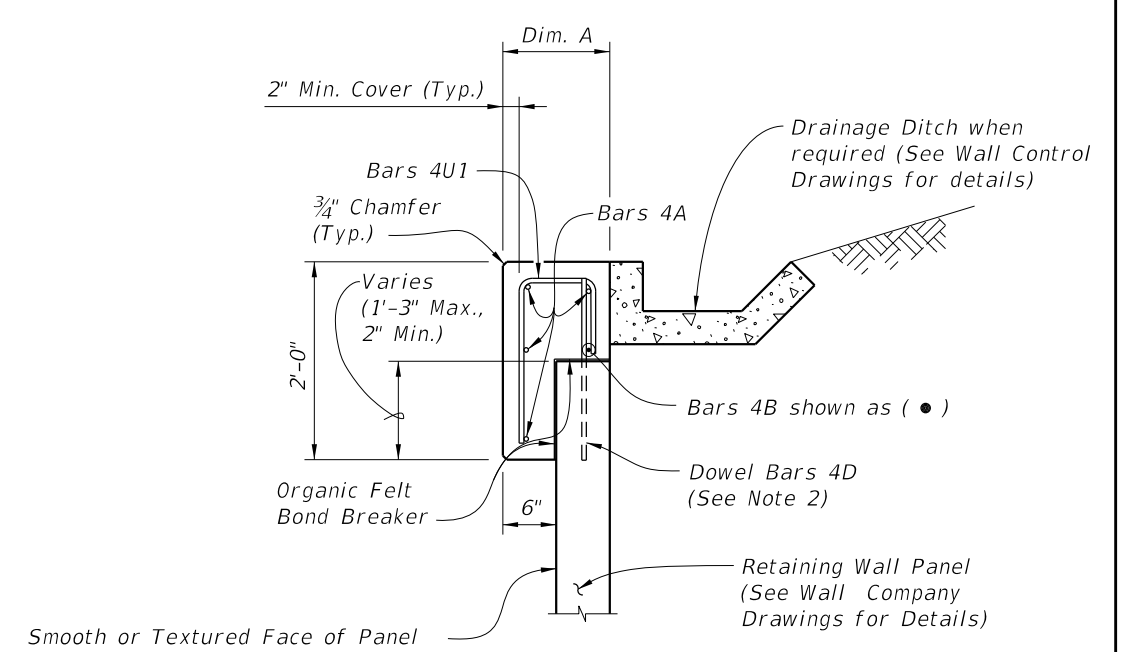

SECTION A-A
C-I-P COPING

Dim. A	Panel width + 6"
Dim. B	Panel width + 1'-0" Min.

PRECAST AND C-I-P COPING NOTES:

1. Provide Class II concrete for slightly aggressive environments or Class IV for moderately or extremely aggressive environments.
2. Dowel Bars 4D extend 11" above the top of retaining wall panel. Field cut as necessary to maintain 2" minimum cover. See Wall Company Drawings for number and spacing of Dowel Bars 4D.
3. Payment for Dowel Bars 4D, Buildup Concrete and Coping will be made under Retaining Wall System (Permanent).

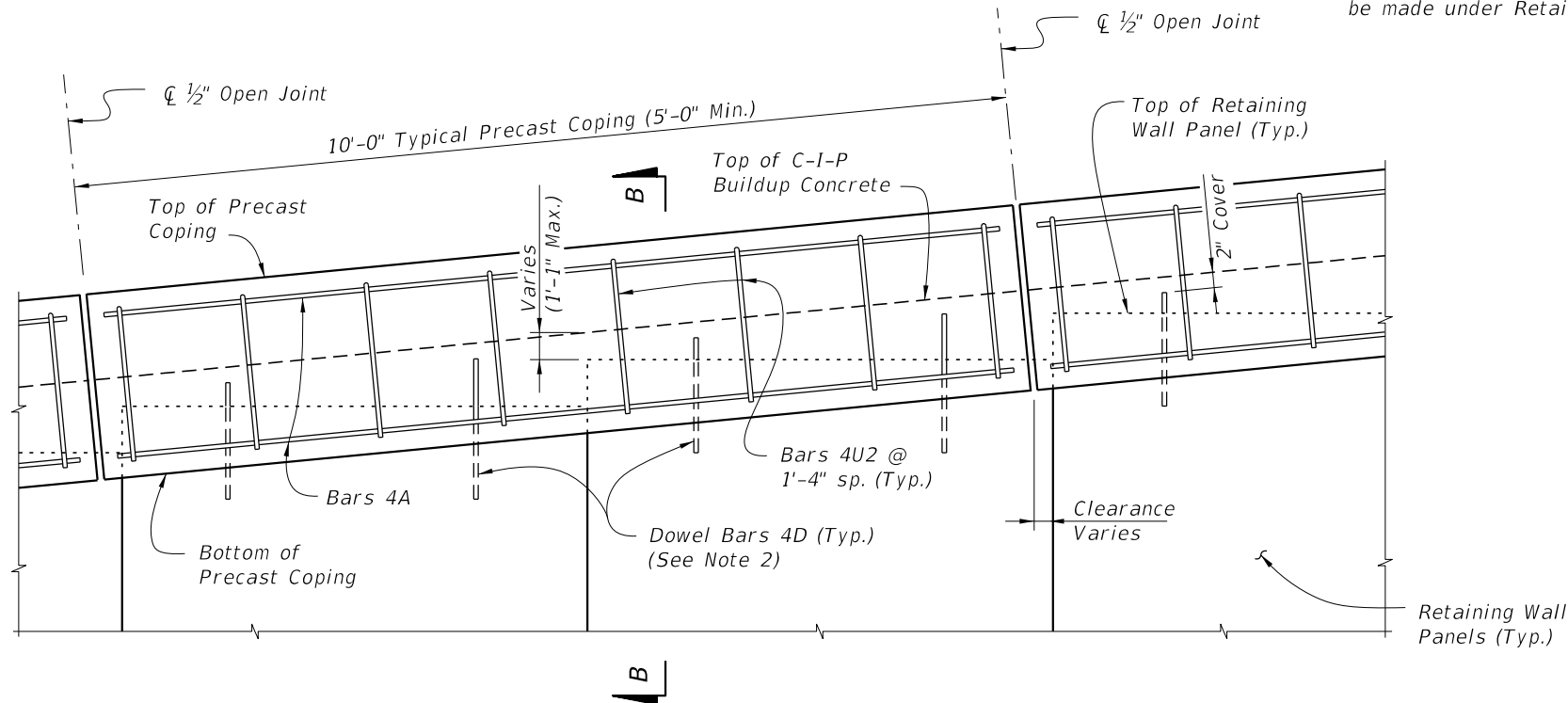

PRECAST COPING - PARTIAL ELEVATION VIEW

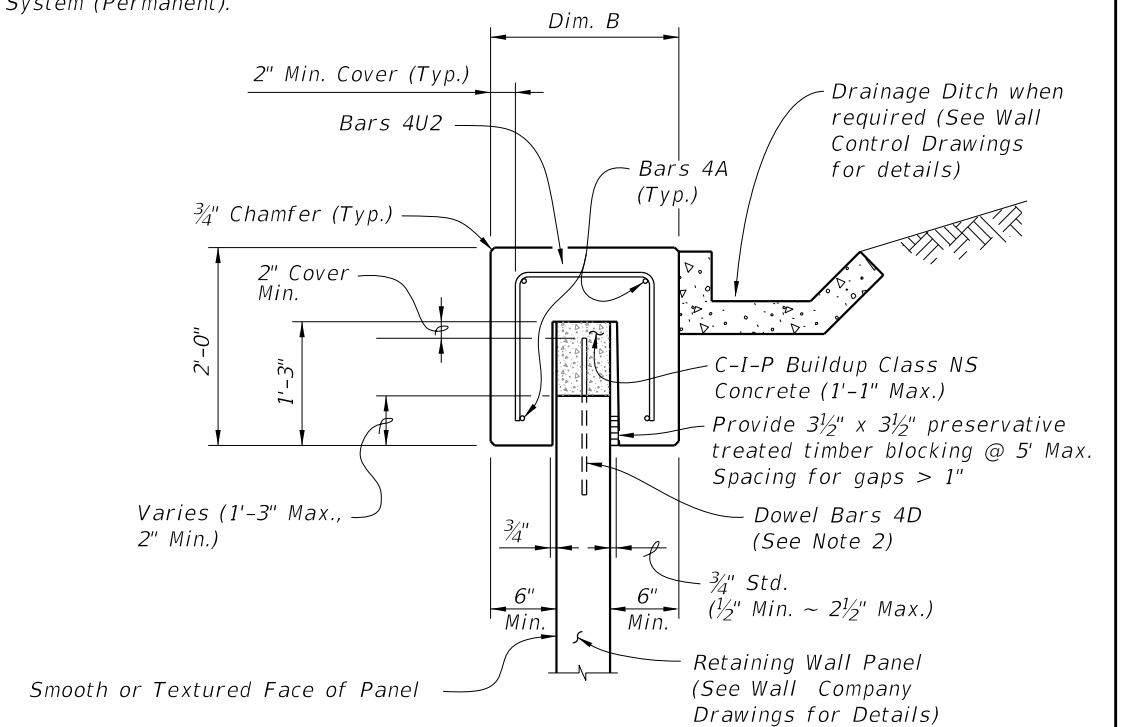

SECTION B-B
PRECAST COPING

10/20/2022 8:51:35 AM

REINFORCING STEEL BENDING DIAGRAMS - PRECAST AND C-I-P COPINGS

BILL OF REINFORCING STEEL

MARK	SIZE	LENGTH (L) ## S or M	LENGTH (L) ## E
A	4	AS REQD.	AS REQD.
B	4	AS REQD.	AS REQD.
D	4	2'-0"	2'-0"
U1	4	Panel width + 4"	Panel width + 4"
U2	4	Dim. B - 4"	Dim. B - 4"
U3	4	Dim. C - 4"	Dim. C - 6"

REINFORCING STEEL NOTES:

- All bar dimensions in the bending diagrams are out to out.
- All reinforcing steel at the open joints will have a 2" minimum cover.
- Bars 4A may be continuous or spliced at the construction joints. Lap splices for Bars 4A will be a minimum of 1'-8".
- The Contractor may use Welded Wire Reinforcement (WWR) when approved by the Engineer. WWR must consist of Deformed wire meeting the requirements of Specification Section 931.

S = Slightly Aggressive
 M = Moderately Aggressive
 E = Extremely Aggressive

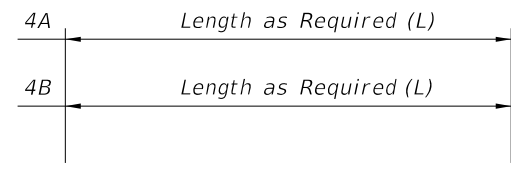

BARS 4A & 4B

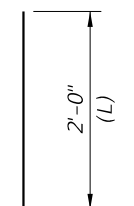

DOWEL BAR 4D

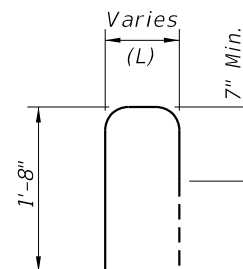

BAR 4U1

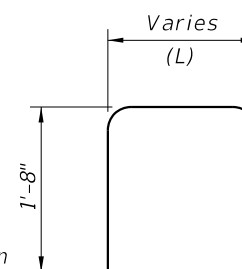

BAR 4U2

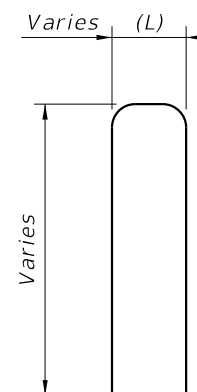

BAR 4U3

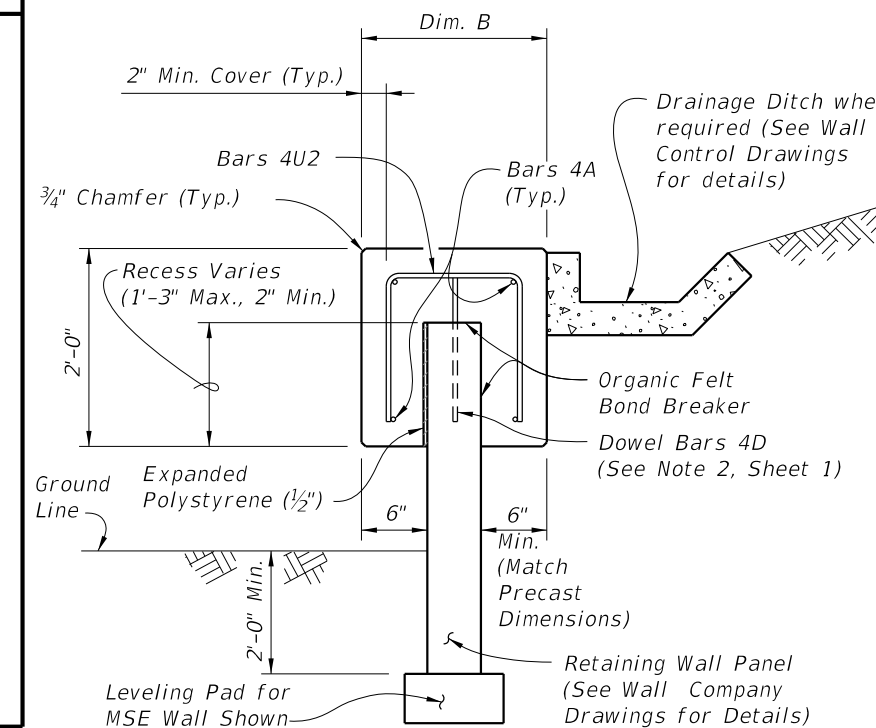

C-I-P COPING USED WITH PRECAST COPING

Note: When precast coping units do not fit the entire length of the retaining wall, use this similar C-I-P coping for short portions between precast coping units. This C-I-P coping may also be used for vertical copings.

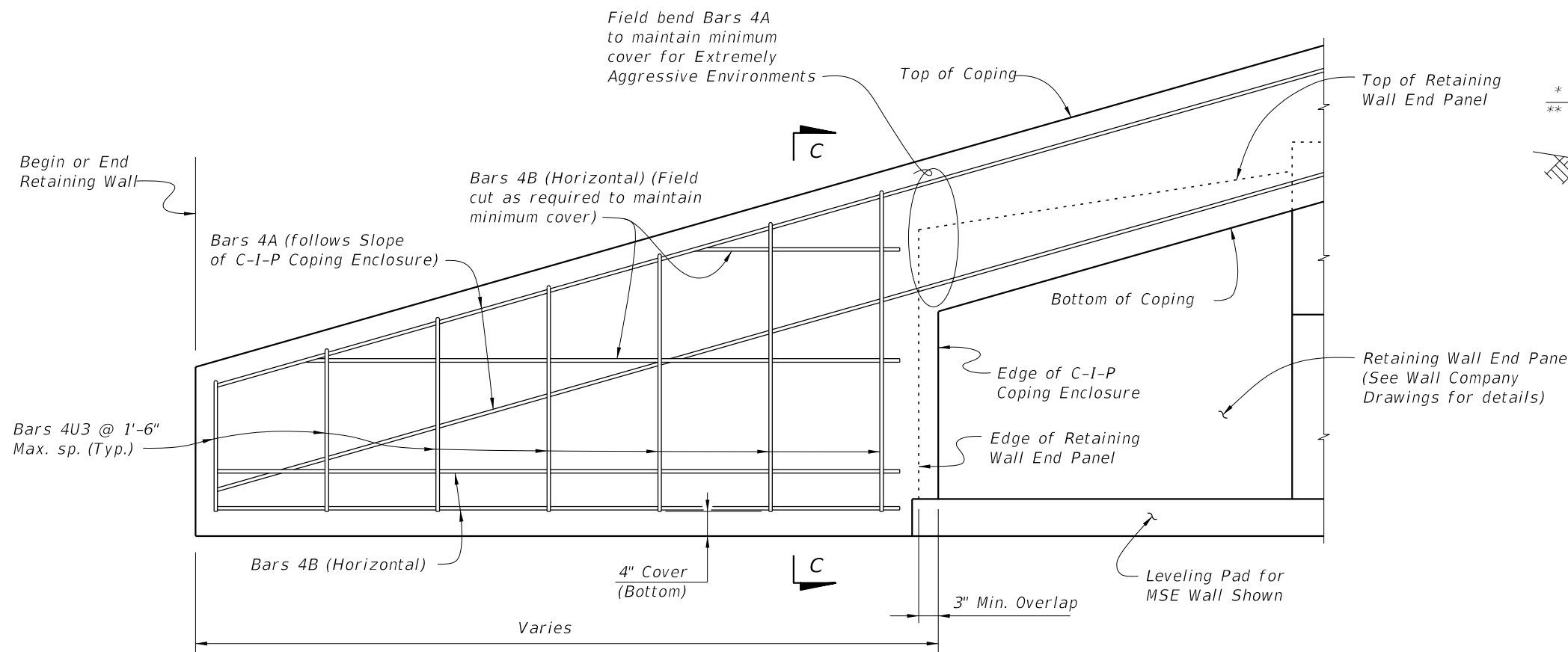

C-I-P COPING ENCLOSURE DETAIL

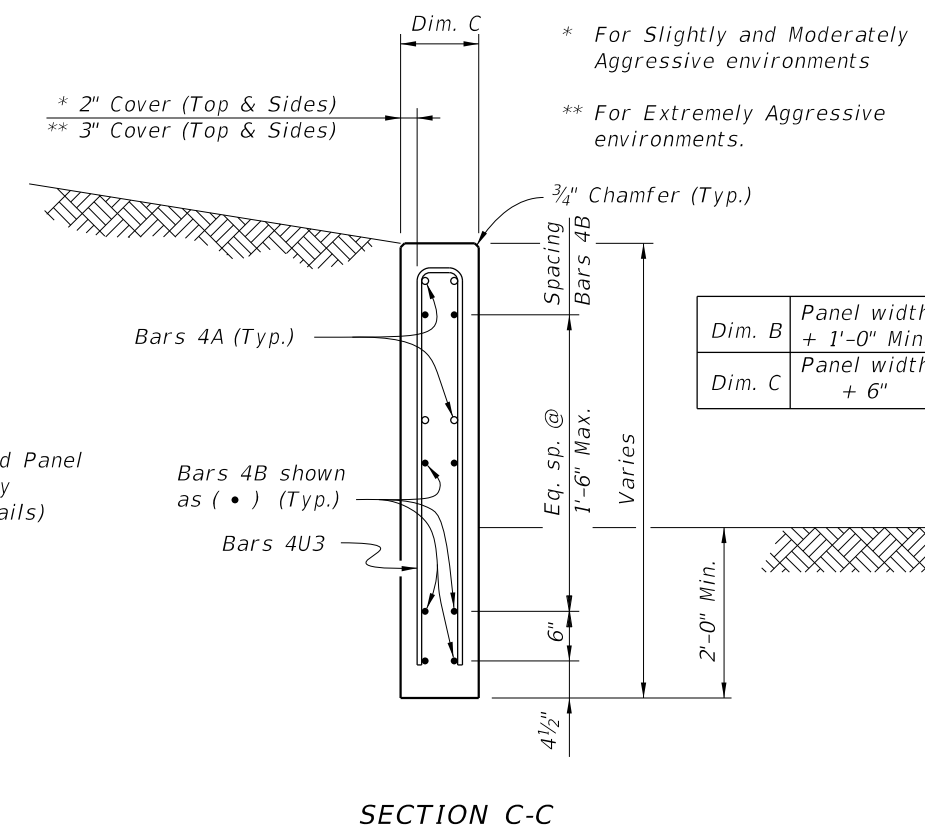

SECTION C-C

10/20/2022 8:51:36 AM

1" Ø Dowel Load Transfer Devices (See Typical Sections for details)

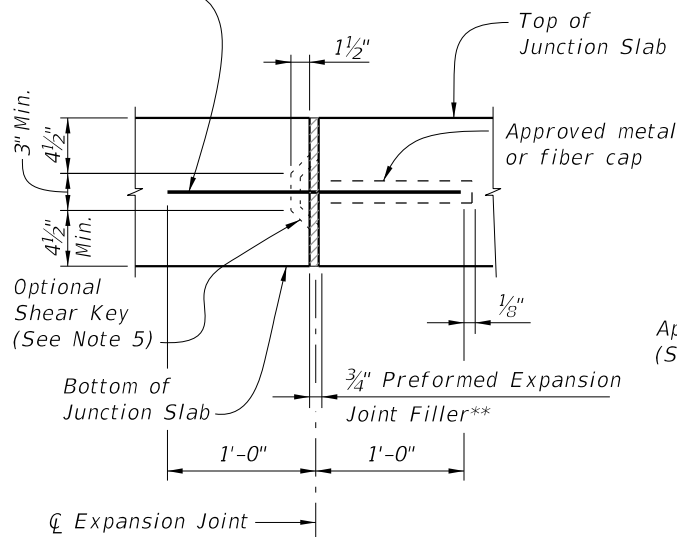

EXPANSION JOINT DETAIL

(Junction Slab expansion joints are to coincide with 3/4" open joints in Concrete Barrier)

** Stay-In-Place Plastic Preformed Bond Breakers are permitted to form joints.

CROSS REFERENCE: For Detail "A", see Sheet 2.
For Detail "B", see Sheet 3.

Begin or End Retaining Wall and Precast or C-I-P Coping

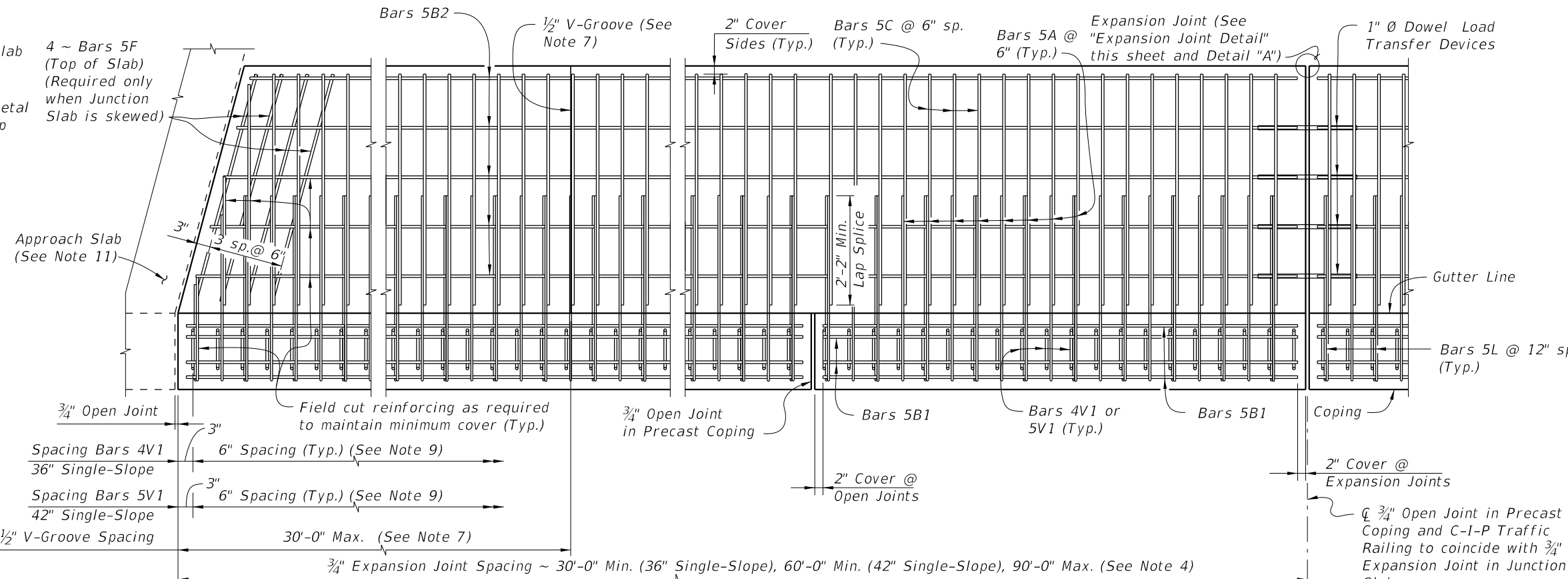

PARTIAL PLAN VIEW FOR 36" SINGLE-SLOPE CONCRETE BARRIER
(Skewed Approach Slab Shown, Perpendicular Approach Slab Similar)
(Precast Coping Shown, C-I-P Coping Similar) (Concrete Barrier not Shown for Clarity)

JUNCTION SLAB NOTES:

- Construct the expansion joints, V-Grooves and face of coping plumb.
- Provide Class II concrete for slightly aggressive environments or Class IV for moderate or extremely aggressive environments.
- Dowel Load Transfer Devices will be hot-dip galvanized ASTM A 36 smooth round bar, or GFRP smooth round bars with a minimum shear strength of 22 ksi in accordance with ASTM D7617. Install Dowel Load Transfer Devices in accordance with Specification Section 350.
- Construct 3/4" Expansion Joints in junction slabs and C-I-P copings plumb and perpendicular or radial to the Gutter Line. Provide at 90'-0" maximum intervals as shown. Provide 3"x3" Mortar plugs in open joints at the base of Concrete Barriers to contain runoff.
- Shear Keys in Junction Slab are required when GFRP bars are used for Dowel Transfer Devices and are optional with steel dowel bars. Tongue Slope on Shear Key must be constant and between 5° to 45° from horizontal.
- Provide and install Preformed Expansion Joint Filler in accordance with Specification Section 932.
- Construct 1/2" V-Grooves in junction slabs and C-I-P copings at 30'-0" maximum intervals as shown. Space V-Grooves equally between 3/4" Expansion Joints and/or Begin or End Junction Slab. V-Groove locations are to coincide with V-Groove locations in the Concrete Barrier.
- Shoulder or Roadway Pavement is required on top of the junction slab for its entire length on the traffic side of the Concrete Barrier. See Typical Sections on Sheets 2 and 3 for details.
- Spacing shown is along the Gutter Line.
- For Precast Coping only, provide Dowel Bars 4D embedded 1'-0" and extended 9" above the top of MSE wall panels. Field cut as necessary to maintain 2" minimum cover to the top of the buildup concrete. See Wall Company Drawings for number and spacing of Dowel Bars 4D.
- The following Indexes contain details of the intersection of the retaining wall at approach slabs:
Index 400-090 - Approach Slabs (Flexible Pavement Approaches)
Index 400-091 - Approach Slabs (Rigid Pavement Approaches)
- Junction slabs with rigid pavement: the two inch increase in concrete barrier height is not required.
- There are two options to accommodate the 2" height transitions :
A. Raise the top of coping elevation 2" and mount either a 36" or 42" standard barrier on top
B. Transition the height of the concrete barrier by gradually extending the toe and back of the barrier 2" while keeping the top of coping elevation even with the gutterline elevation.
- The barrier construction joint must be at the interface of the coping and the barrier base. Embed the V bars a minimum of 9" below the construction joint.
- For embedded conduit and junction boxes, see Index 630-010.

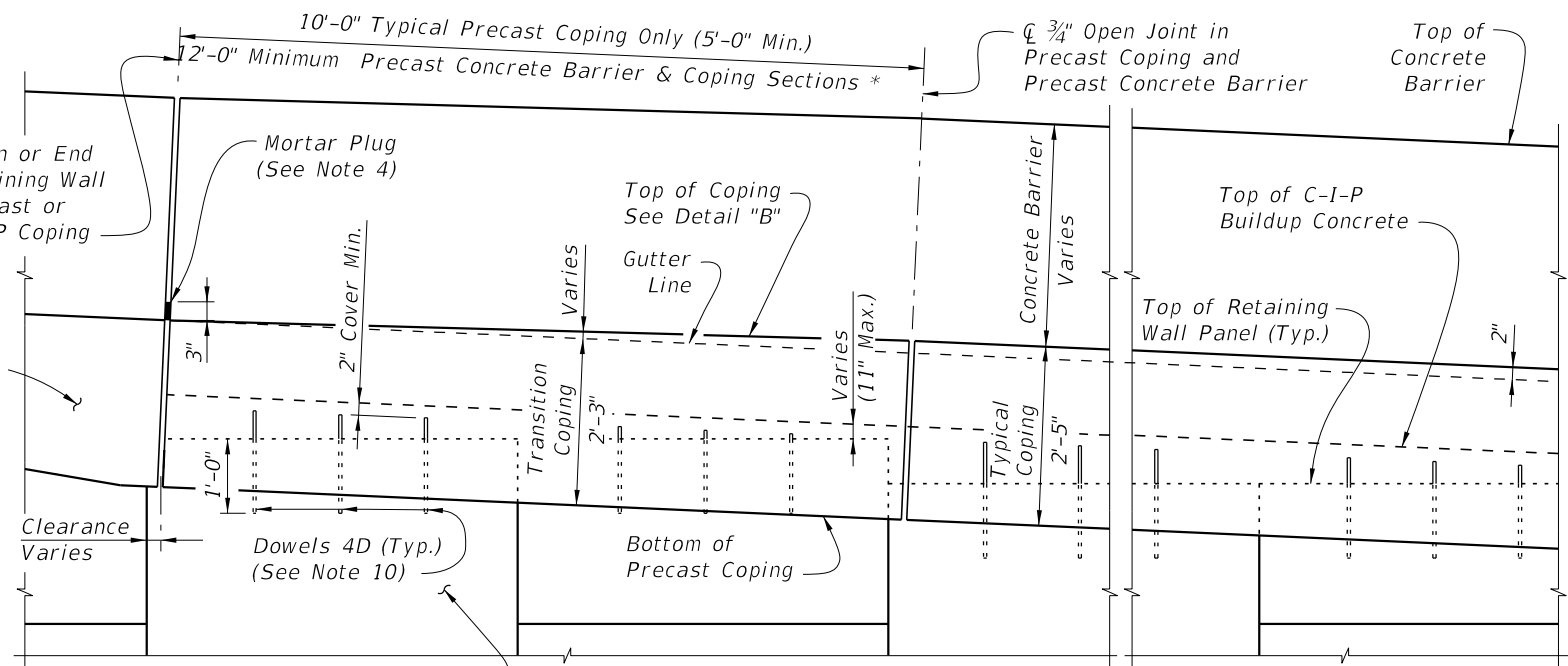

PARTIAL ELEVATION VIEW
(Precast Coping and Junction Slab Reinforcing not Shown for Clarity)
(Precast Coping Shown, C-I-P Coping Similar)

* C-I-P End Section must be ≥ 12'-0".

10/20/2022 8:51:37 AM

LAST REVISION 11/01/21	DESCRIPTION:	 FY 2023-24 STANDARD PLANS	CONCRETE BARRIER/JUNCTION SLAB - WALL COPING	INDEX 521-610	SHEET 1 of 3
---------------------------	--------------	--	---	------------------	-----------------

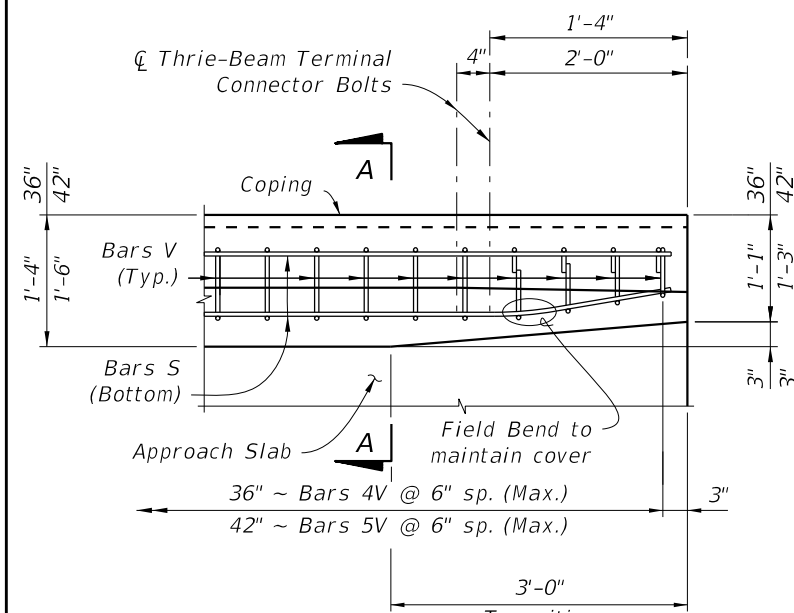

PLAN - RAILING END TRANSITION
(Showing Bars V and S)

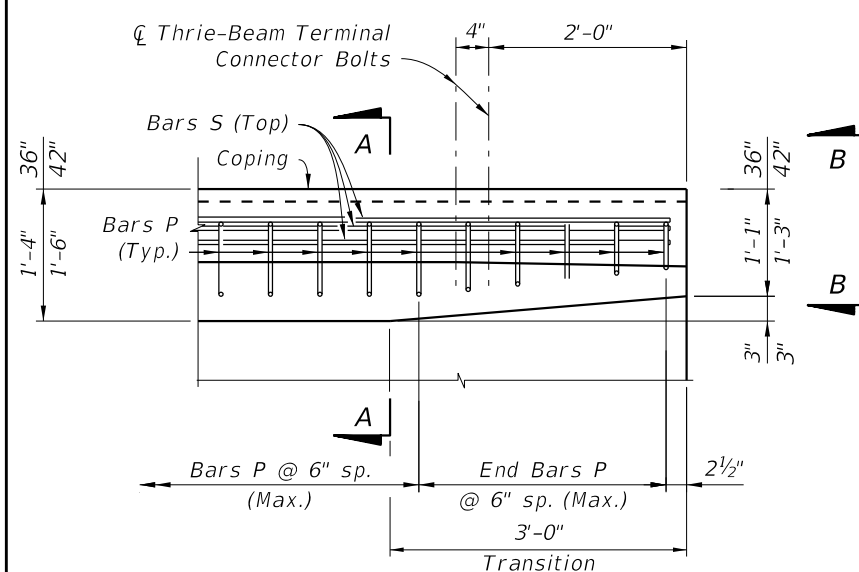

PLAN - RAILING END TRANSITION
(Showing Bars P and S)

RAILING END TRANSITION DETAILS ***

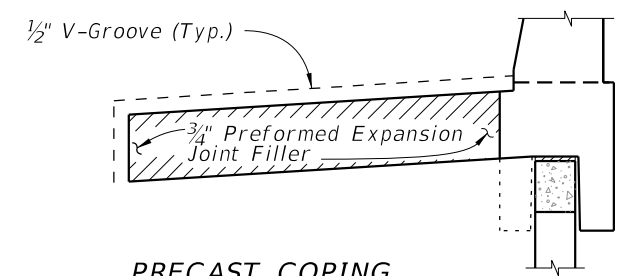

PRECAST COPING

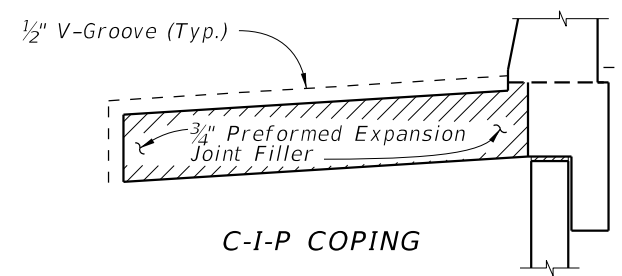

C-I-P COPING

DETAIL "A"
(Showing Locations of 1/2" V-Grooves and 3/4" Preformed Expansion Joint Filler)

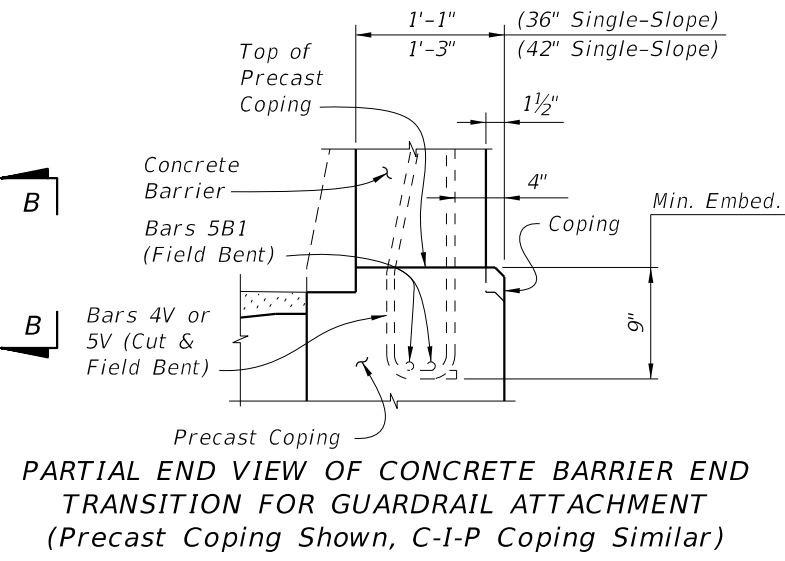

PARTIAL END VIEW OF CONCRETE BARRIER END TRANSITION FOR GUARDRAIL ATTACHMENT
(Precast Coping Shown, C-I-P Coping Similar)

*** Transition the Concrete Barrier Height to 32" as shown in Index 521-427 or 521-428. See Note 10.

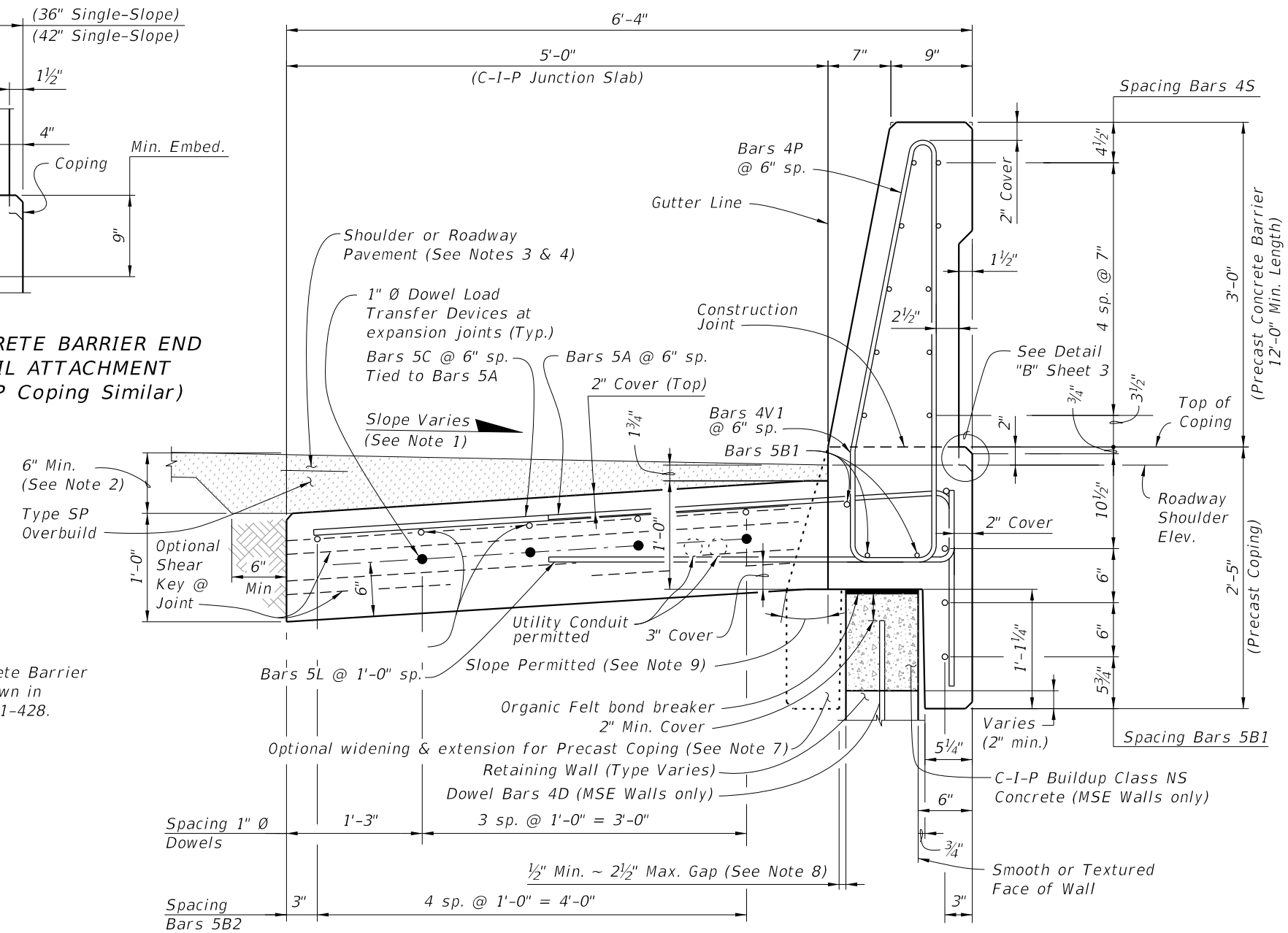

TYPICAL SECTION THRU PRECAST 36" SINGLE-SLOPE CONCRETE BARRIER AND COPING WITH C-I-P JUNCTION SLAB

NOTES:

1. Match Cross Slope of Travel Lane or Shoulder.
2. Vary Junction Slab slope based on roadway cross slope to maintain a minimum 6" asphalt depth at the edge of the slab as shown.
3. For Rigid Pavement (Concrete), Junction Slab may be thickened to match finished grade. Vary the Junction Slab slope to maintain a minimum 1'-6" thickness at the edge of the slab.
4. See Roadway Plans for asphalt shoulder, roadway pavement and overbuild.
5. Minimum length of Junction Slab between expansion joints is 30'-0".
6. At the Contractor's option, mechanical couplers may be used to splice reinforcing. Complete details, including reinforcement lengths are required in the Shop Drawings. Provide mechanical couplers in accordance with Specification Section 415. Mechanical couplers shall develop 125% of the bar yield strength.
7. Contractor to maintain stability of precast coping/Concrete Barrier prior to junction slab completion. In the Shop Drawings, show reinforcement for optional extension required for stability, shipping and handling. Maintain 2" minimum concrete cover.
8. When the air gap between the precast coping extension and retaining wall exceeds 2 1/2", fill gap with full depth Expanded Polystyrene to provide a maximum 2 1/2" air gap.
9. Angle varies ~ 0° min., 25° max.
10. The height of the concrete barrier at the guardrail connection is 32" from the riding surface for all pavement types. See Index 534-001 for connection details.

SINGLE-SLOPE CONCRETE BARRIERS

10/20/2022 8:51:36 AM

LAST REVISION 11/01/22	REVISION	DESCRIPTION:		FY 2023-24 STANDARD PLANS	CONCRETE BARRIER/JUNCTION SLAB - WALL COPING	INDEX 521-610	SHEET 2 of 3
---------------------------	----------	--------------	--	--------------------------------------	---	------------------	-----------------

REINFORCING STEEL BENDING DIAGRAMS

BILL OF REINFORCING STEEL

MARK	SIZE	LENGTH			
		PRECAST COPING FOR SINGLE-SLOPE		C-I-P COPING FOR SINGLE-SLOPE	
		(36")	(42")	(36")	(42")
A	5	5'-3"	5'-5"	7'-10"	8'-0"
B1	5	11'-6"	9'-6"	AS REQD.	AS REQD.
B2	5	AS REQD.	AS REQD.	AS REQD.	AS REQD.
C	5	4'-10"	4'-10"	N/A	N/A
F	5	4'-10"	4'-10"	4'-10"	4'-10"
L	5	4'-5"	4'-5"	4'-5"	4'-5"
P	4	5'-11"	N/A	5'-11"	N/A
P	5	N/A	7'-0"	N/A	7'-0"
S	4	11'-6"	N/A	AS REQD.	N/A
S	6	N/A	9'-6"	N/A	AS REQD.
V1	4	5'-9"	N/A	5'-9"	N/A
V1	5	N/A	6'-4"	N/A	6'-4"
1" Ø Dowel	Smooth Bar	2'-0"	2'-0"	2'-0"	2'-0"

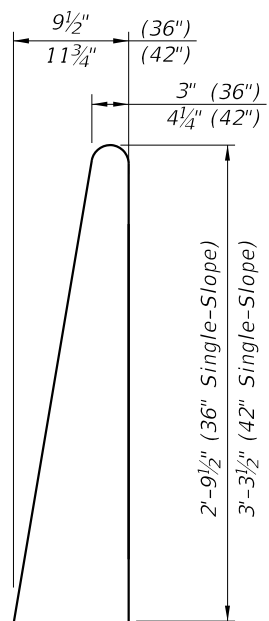

**STIRRUP BAR
4P (36") 5P (42")**

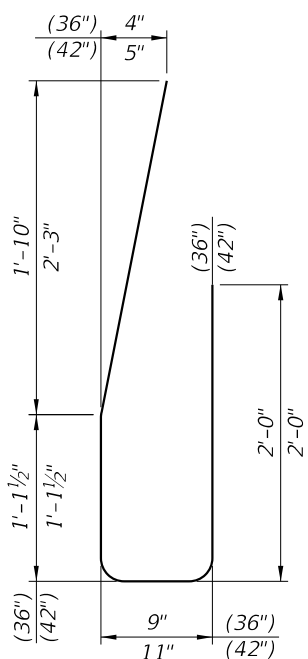

**STIRRUP BAR
4V1 (36") 5V1 (42")**

See Table
BARS 5B1, 5B2, 5C, 5F, 4S, & 6S

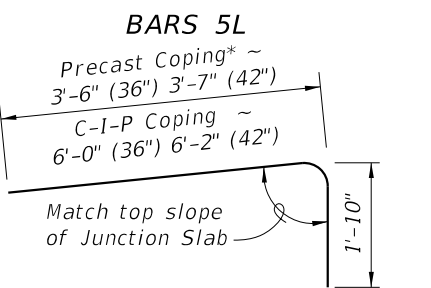
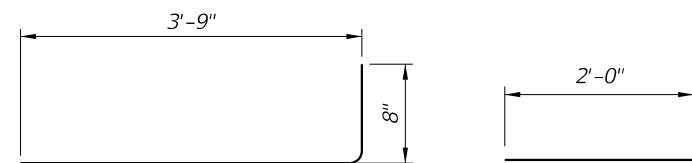

BAR 5A

* See Note 5 & 6

REINFORCING STEEL NOTES:

- All bar dimensions in the bending diagrams are out to out.
- All reinforcing steel at expansion and open joints will have a 2" minimum cover.
- Lap splices for Bars 5B & 5S will be a minimum of 2'-2".
- For Precast Copings only, lap splice Bars 5A with Bars 5C. Lap splices will be a minimum of 2'-2".
- The Contractor may use either full length Bars 5A or lap splice with Bars 5C at Bars 5A for C-I-P Copings.
- Dimension shown is for lap splice option. For mechanical coupler option, this dimension is 1'-2 1/2" (36" Single-Slope) or 1'-4 1/2" (42" Single-Slope).
- Dimension shown is for lap splice option. For mechanical coupler option, this dimension is 4'-8".
- When approved by the Engineer, the Contractor may use deformed Welded Wire Reinforcement (WWR) meeting the requirements of Specification Section 931.
- Contractor may use a single #4 stirrup for Bars 4P and 4V1, or a single #5 stirrup for Bars 5P and 5V1.

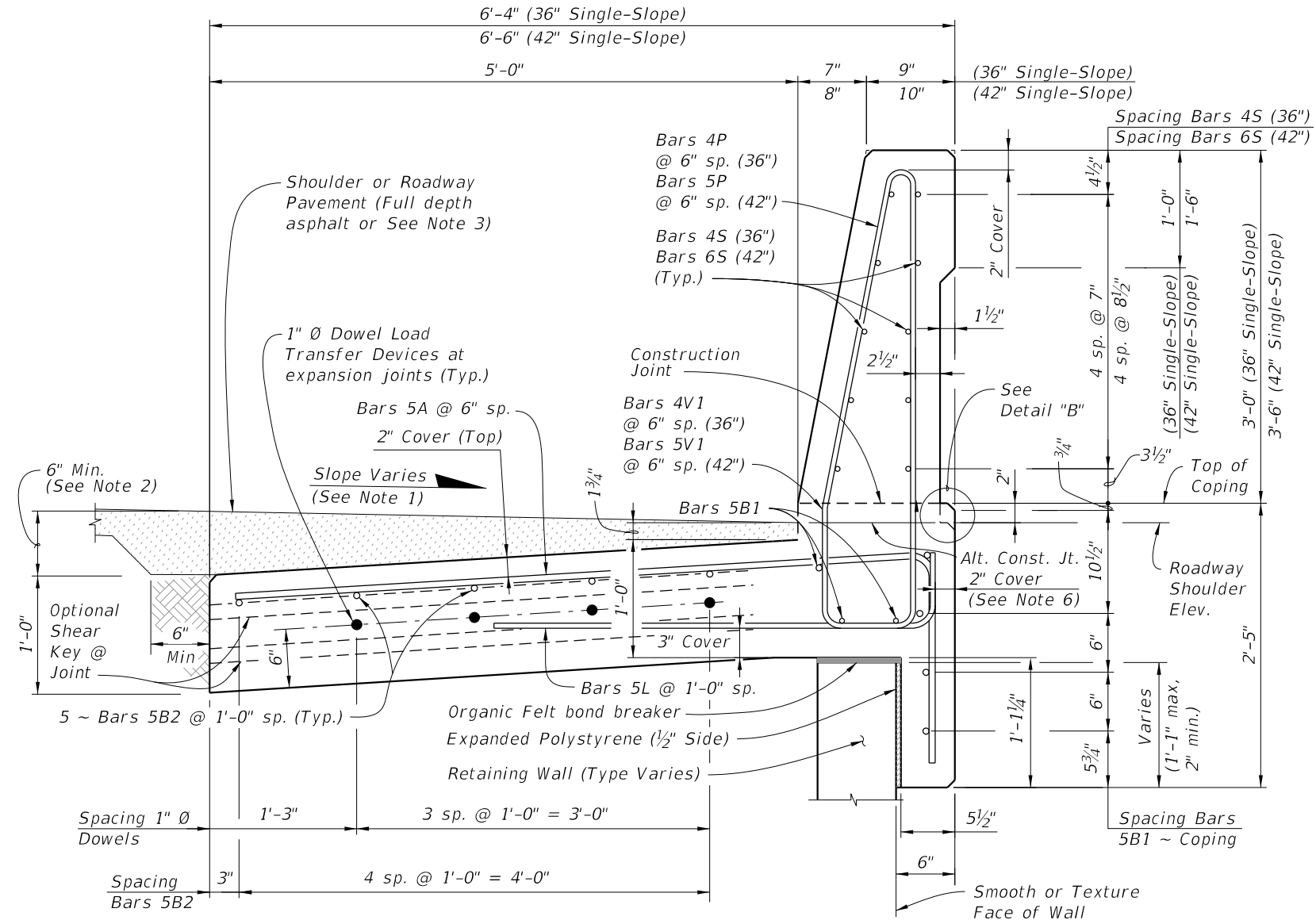

**TYPICAL SECTION THRU C-I-P CONCRETE BARRIER WITH C-I-P JUNCTION SLAB AND C-I-P COPING
(PRECAST COPING SIMILAR WITH C-I-P BUILDUP)**

NOTES:

- Match Cross Slope of Travel Lane or Shoulder.
- Vary the Junction Slab slope based on the roadway cross slope to maintain a minimum 6" asphalt depth at the edge of the slab.
- For Rigid Pavement (Concrete), Junction Slab may be thickened to match finish grade. Vary the Junction Slab slope to maintain a minimum 1'-6" thickness at the inside edge of the slab.
- Minimum length of Junction Slab between expansion joints is 30'-0" for 36" Single-Slope or 60'-0" for 42" Single-Slope.
- Contractor to maintain stability of precast coping prior to junction slab completion. In the Shop Drawings, show reinforcement for optional extension required for stability, shipping and handling. Maintain 2" minimum concrete cover.
- If slip forming is used, submit shop drawings for approval showing 2 1/2" side cover with the Typical Section dimensions adjusted.

ESTIMATED QUANTITIES FOR C-I-P

ITEM	UNIT	QUANTITY	
		(36")	(42")
Concrete	CY/LF	0.376	0.420
Reinforcing Steel (Typical) (excludes Bars 5C & 5F)	LB/LF	62.45	82.17
Additional Reinf. @ Expansion Joint (Steel Dowels)	LB	21.36	21.36

(The above concrete quantities are based on a max. superelevation of 6.25%)

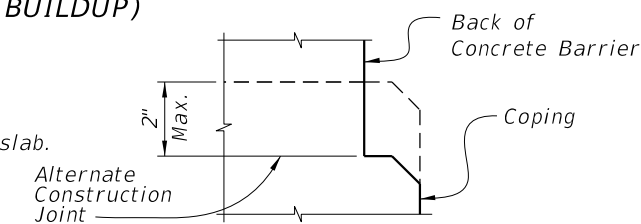

**DETAIL "B"
OPTIONAL NOTCH AT TOP OF COPING**

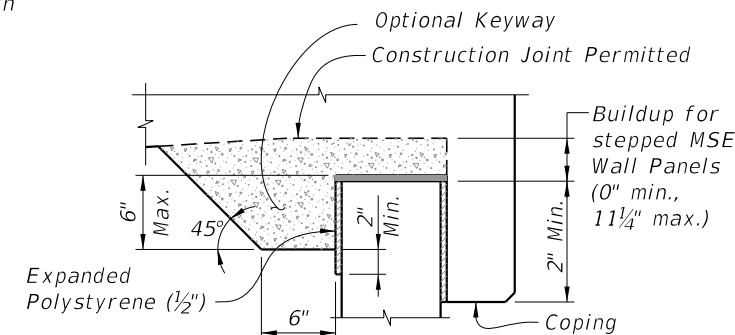

**BUILDUP FOR STEPPED MSE WALL PANELS
AND C-I-P COPING**

SINGLE-SLOPE CONCRETE BARRIERS

10/20/2022 8:51:39 AM

LAST REVISION	DESCRIPTION:
11/01/22	



**FY 2023-24
STANDARD PLANS**

**CONCRETE BARRIER/JUNCTION SLAB
- WALL COPING**

INDEX
521-610

SHEET
3 of 3

1" Ø FRP Dowel Load Transfer Devices (See Typical Sections for details)

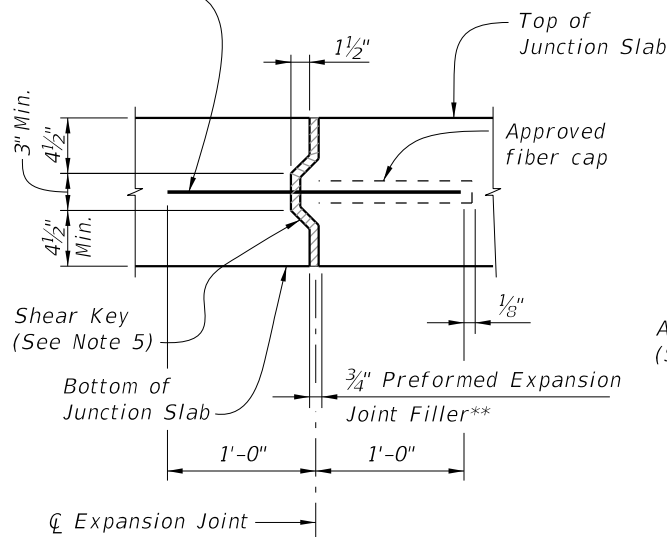

EXPANSION JOINT DETAIL

(Junction Slab expansion joints are to coincide with 3/4" open joints in Concrete Barrier)

** Stay-In-Place Plastic Preformed Bond Breakers are permitted to form joints.

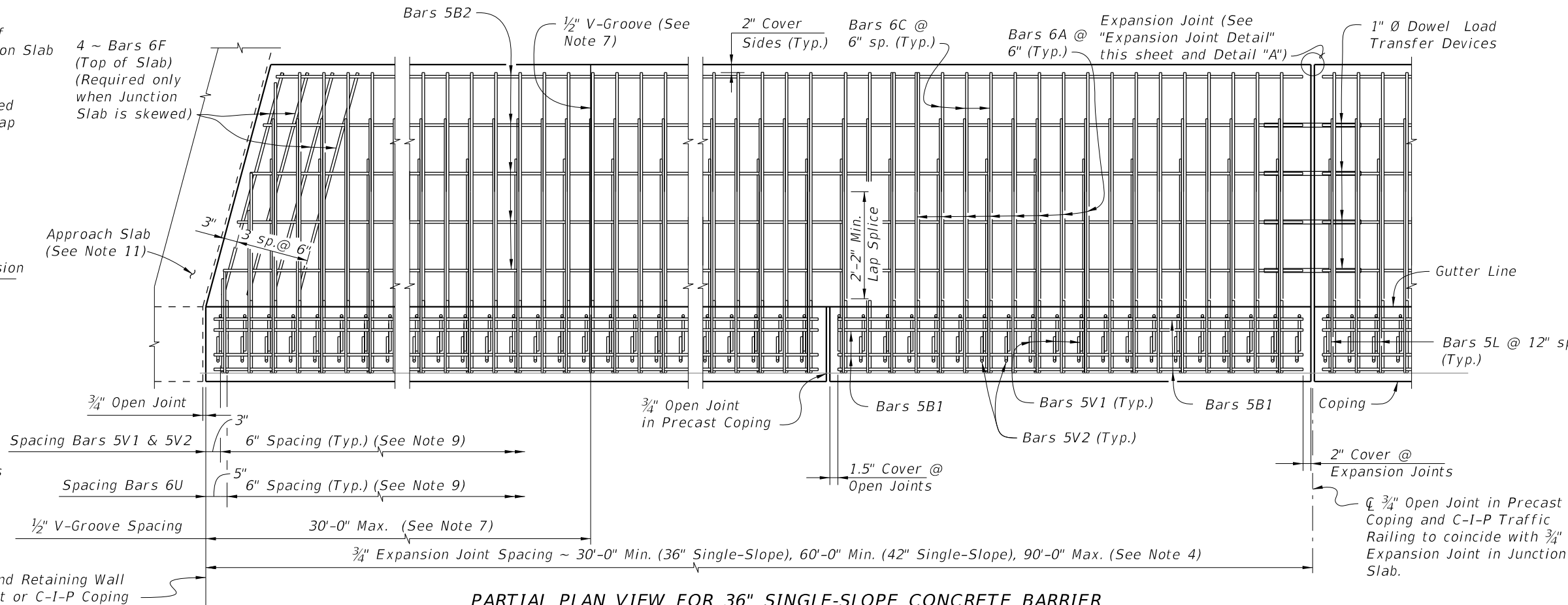

PARTIAL PLAN VIEW FOR 36" SINGLE-SLOPE CONCRETE BARRIER
(Skewed Approach Slab Shown, Perpendicular Approach Slab Similar)
(Precast Coping Shown, C-I-P Coping Similar) (Concrete Barrier not Shown for Clarity)

CROSS REFERENCE: For Detail "A", see Sheet 2.
For Detail "B", see Sheet 3.

JUNCTION SLAB NOTES:

1. Construct the expansion joints, V-Grooves and face of coping plumb.
2. Provide Class II concrete.
3. Dowel Load Transfer Devices will be GFRP smooth round bars with a minimum shear strength of 22 ksi in accordance with ASTM D7617. Install Dowel Load Transfer Devices in accordance with Specification Section 350.
4. Construct 3/4" Expansion Joints in junction slabs and C-I-P copings plumb and perpendicular or radial to the Gutter Line. Provide at 90'-0" maximum intervals as shown. Provide 3"x3" Mortar plugs in open joints at the base of Concrete Barriers to contain runoff.
5. Shear Keys in Junction Slab are required. Tongue Slope on Shear Key must be constant and between 5° to 45° from horizontal.
6. Provide and install Preformed Expansion Joint Filler in accordance with Specification Section 932.
7. Construct 1/2" V-Grooves in junction slabs and C-I-P copings at 30'-0" maximum intervals as shown. Space V-Grooves equally between 3/4" Expansion Joints and/or Begin or End Junction Slab. V-Groove locations are to coincide with V-Groove locations in the Concrete Barrier.
8. Shoulder or Roadway Pavement is required on top of the junction slab for its entire length on the traffic side of the Concrete Barrier. See Typical Sections on Sheets 2 and 3 for details.
9. Spacing shown is along the Gutter Line.
10. For Precast Coping only, provide Dowel Bars 4D embedded 1'-0" and extended 9" above the top of MSE wall panels. Field cut as necessary to maintain 2" minimum cover to the top of the buildup concrete. See Wall Company Drawings for number and spacing of Dowel Bars 4D.
11. The following Indexes contain details of the intersection of the retaining wall at approach slabs:
Index 400-090 - Approach Slabs (Flexible Pavement Approaches)
Index 400-091 - Approach Slabs (Rigid Pavement Approaches)
12. Junction slabs with rigid pavement: the two inch increase in concrete barrier height is not required.
13. There are two options to accommodate the 2" height transitions :
A. Raise the top of coping elevation 2" and mount either a 36" or 42" standard barrier on top
B. Transition the height of the concrete barrier by gradually extending the toe and back of the barrier 2" while keeping the top of coping elevation even with the gutterline elevation.
14. The barrier construction joint must be at the interface of the coping and the barrier base. Embed the V bars a minimum of 9" below the construction joint.
15. For embedded conduit and junction boxes, see Index 630-010.

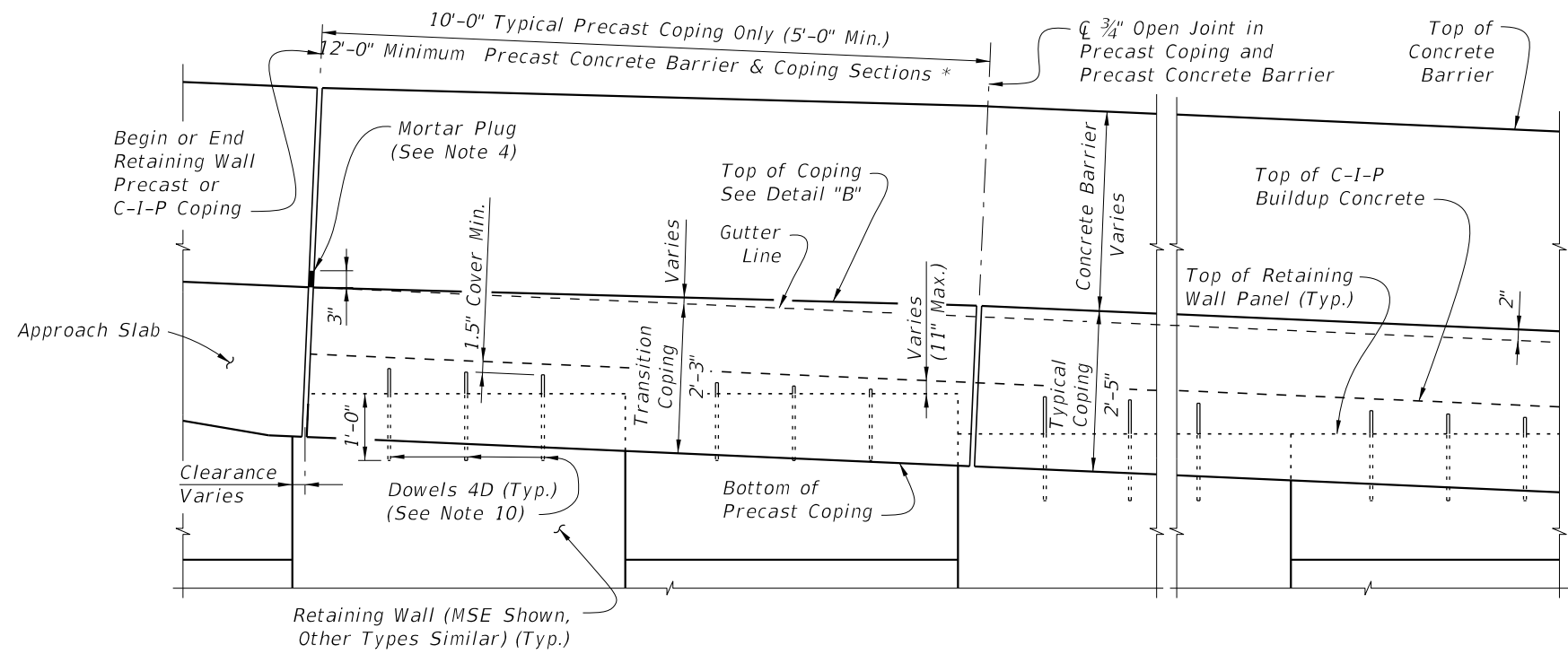

PARTIAL ELEVATION VIEW
(Precast Coping and Junction Slab Reinforcing not Shown for Clarity)
(Precast Coping Shown, C-I-P Coping Similar)

* C-I-P End Section must be ≥ 12'-0".

10/20/2022 8:51:41 AM

LAST REVISION 11/01/21	REVISION	DESCRIPTION:		FY 2023-24 STANDARD PLANS	CONCRETE BARRIER/JUNCTION SLAB - WALL COPING (FRP)	INDEX 521-611	SHEET 1 of 4
---------------------------	----------	--------------	--	------------------------------	---	------------------	-----------------

SINGLE-SLOPE CONCRETE BARRIERS

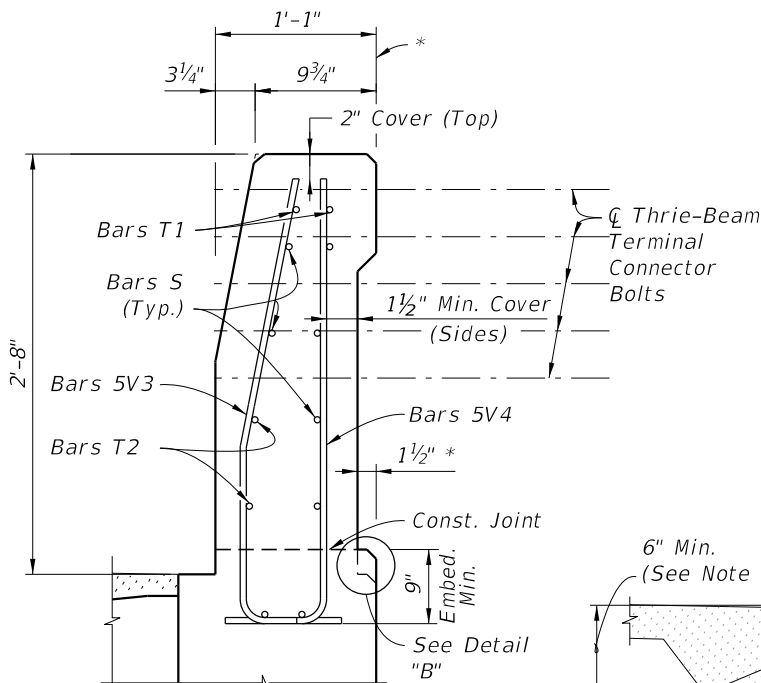
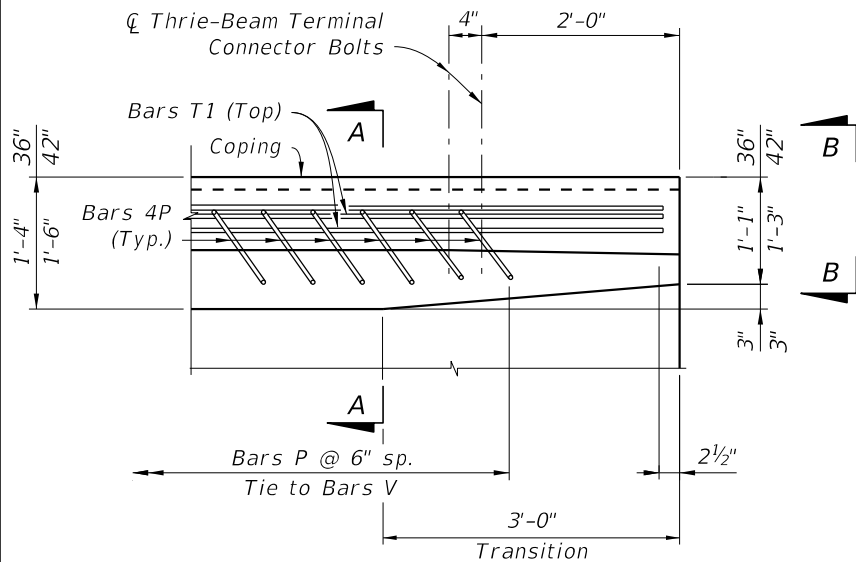
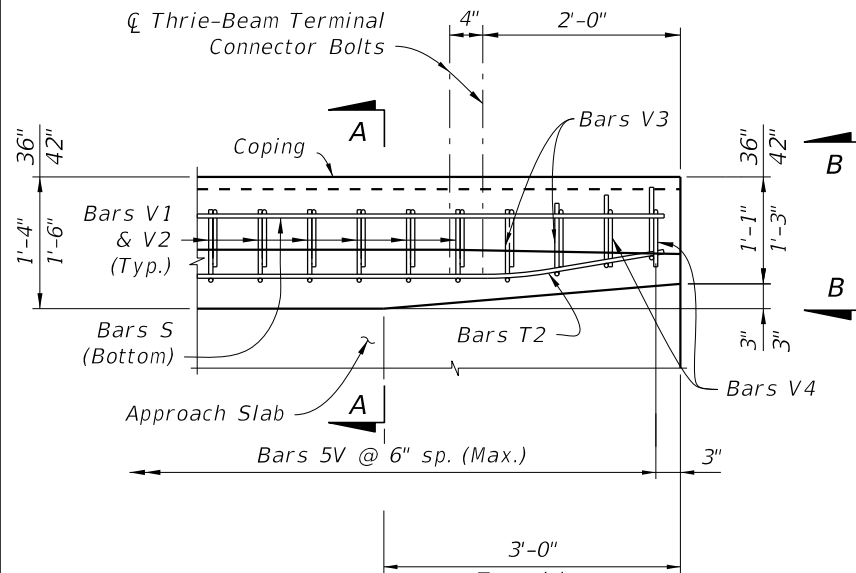

PARTIAL END VIEW OF CONCRETE BARRIER END TRANSITION FOR GUARDRAIL ATTACHMENT (Precast Coping Shown, C-I-P Coping Similar)

*** Transition the Concrete Barrier Height to 32" as shown in Index 521-427 or 521-428. See Note 9.

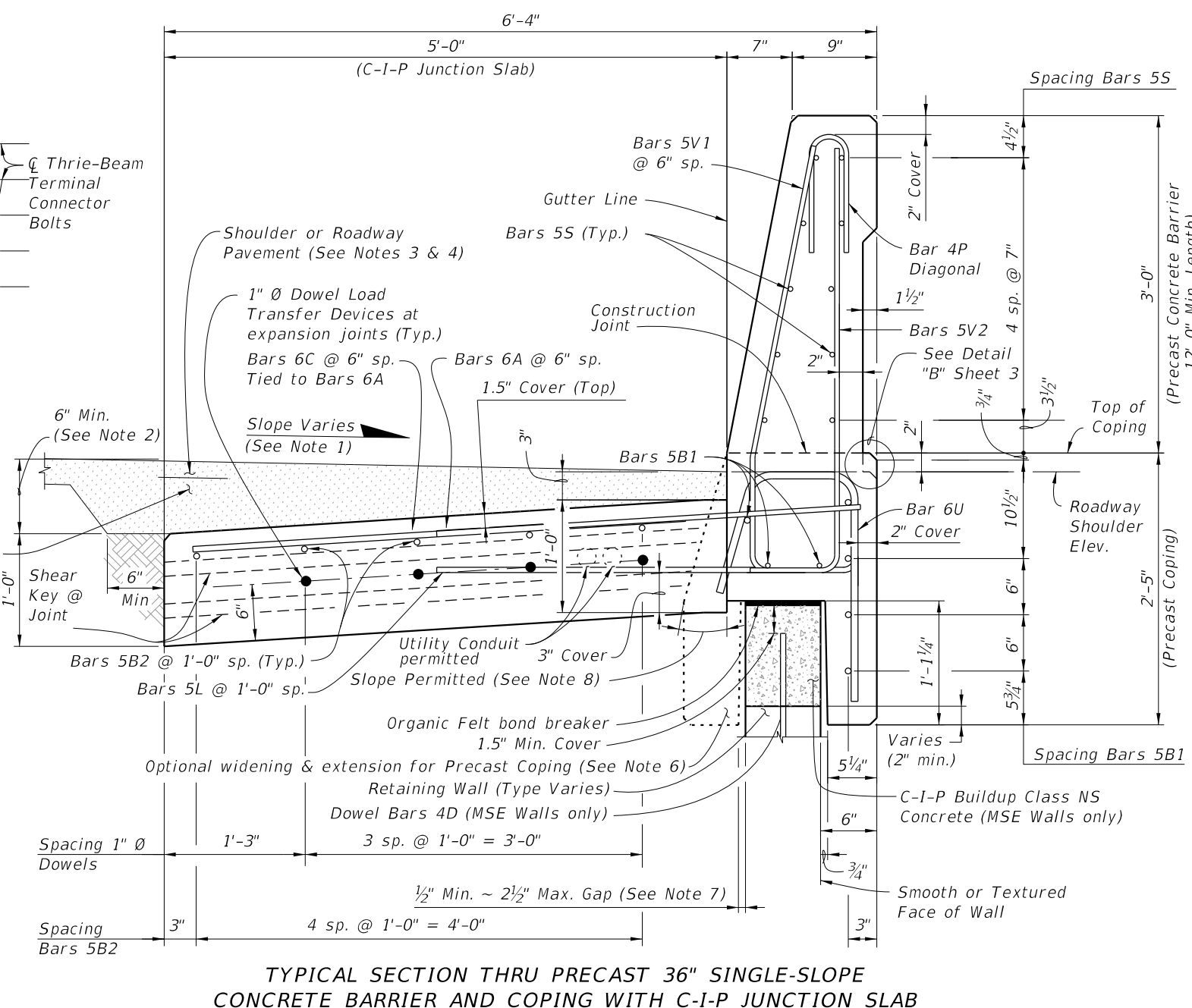

TYPICAL SECTION THRU PRECAST 36" SINGLE-SLOPE CONCRETE BARRIER AND COPING WITH C-I-P JUNCTION SLAB

NOTES:

1. Match Cross Slope of Travel Lane or Shoulder.
2. Vary Junction Slab slope based on roadway cross slope to maintain a minimum 6" asphalt depth at the inside edge of the slab as shown.
3. For Rigid Pavement (Concrete), Junction Slab may be thickened to match finished grade. Vary the Junction Slab slope to maintain a minimum 1'-6" asphalt thickness at the inside edge of the slab.
4. See Roadway Plans for asphalt shoulder, roadway pavement and overbuild.
5. Minimum length of Junction Slab between expansion joints is 30'-0".
6. Contractor to maintain stability of precast coping/Concrete Barrier prior to junction slab completion. In the Shop Drawings, show reinforcement for optional extension required for stability, shipping and handling. Maintain 1 1/2" minimum concrete cover.
7. When the air gap between the precast coping extension and retaining wall exceeds 2 1/2", fill gap with full depth Expanded Polystyrene to provide a maximum 2 1/2" air gap.
8. Angle varies ~ 0° min., 25° max.
9. The height of the concrete barrier at the guardrail connection is 32" from the riding surface for all pavement types. See Index 534-001 for connection details.
10. 2" cover allows for 1/2" variance due to slip forming.

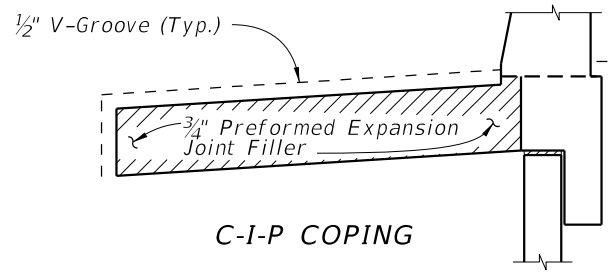
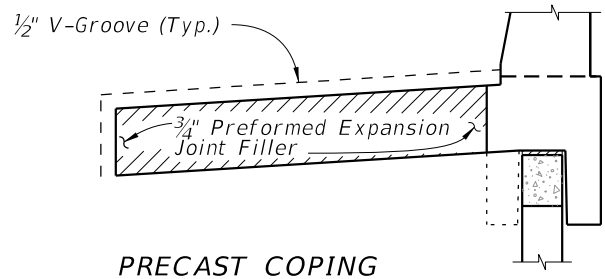

DETAIL "A"

(Showing Locations of 1/2" V-Grooves and 3/4" Preformed Expansion Joint Filler)

RAILING END TRANSITION DETAILS ***

SINGLE-SLOPE CONCRETE BARRIERS

LAST REVISION		DESCRIPTION:		FDOT	FY 2023-24 STANDARD PLANS		CONCRETE BARRIER/JUNCTION SLAB - WALL COPING (FRP)		INDEX	SHEET
11/01/22										521-611

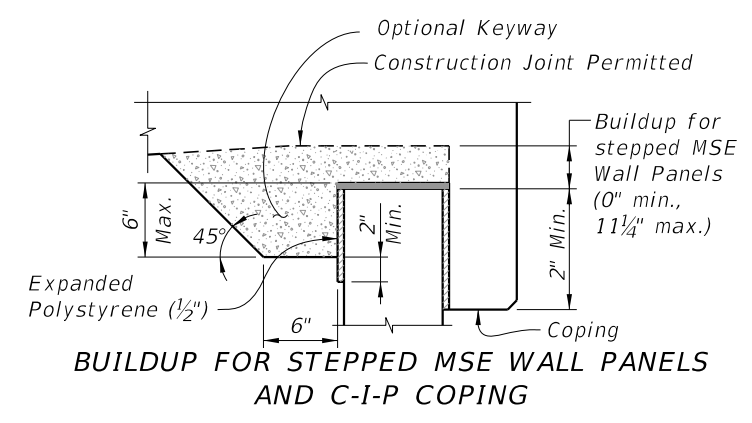
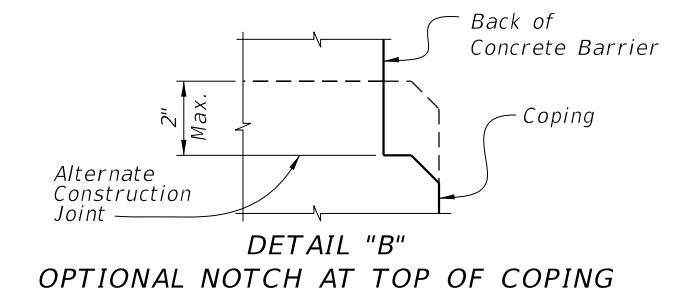
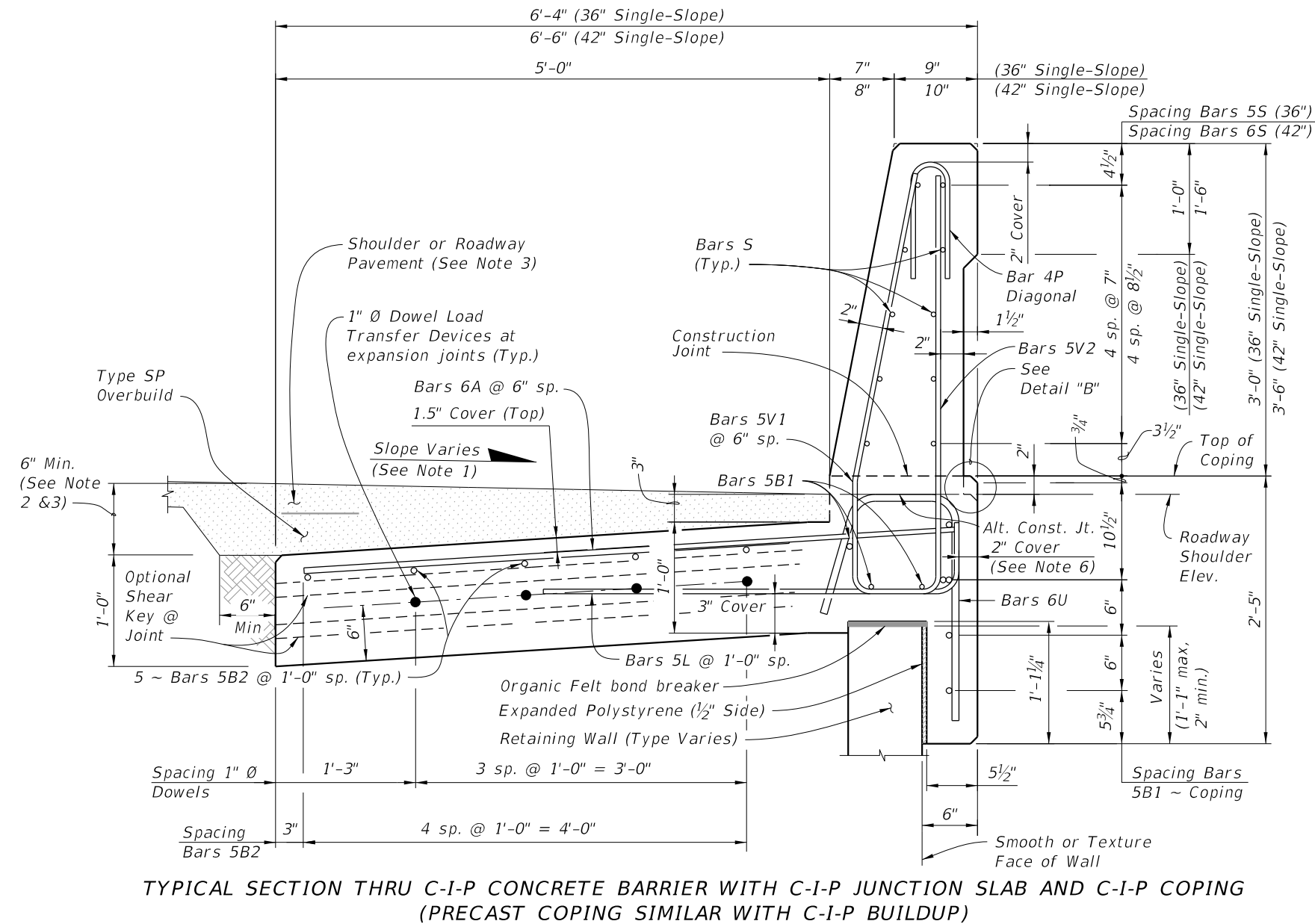

- NOTES:**
1. Match Cross Slope of Travel Lane or Shoulder.
 2. Vary the Junction Slab slope based on the roadway cross slope to maintain a minimum 6" asphalt depth at the inside edge of the slab.
 3. For Rigid Pavement (Concrete), Junction Slab may be thickened to match finish grade. Vary the Junction Slab slope to maintain a minimum 1'-6" thickness at the inside edge of the slab.
 4. Minimum length of Junction Slab between expansion joints is 30'-0" for 36" Single-Slope or 60'-0" for 42" Single-Slope.
 5. Contractor to maintain stability of precast coping prior to junction slab completion. In the Shop Drawings, show reinforcement for optional extension required for stability, shipping and handling. Maintain 1.5" minimum concrete cover.
 6. 2" cover allows for 1/2" variance due to slip forming.

ESTIMATED QUANTITIES FOR C-I-P			
ITEM	UNIT	QUANTITY (36")	QUANTITY (42")
Concrete	CY/LF	0.376	0.420
GFRP (excludes Bars 6C & 6F)	LF/LF	69.42	72.41
Additional Reinf. @ Expansion Joint (Dowels)	LF	8.00	8.00

(The above concrete quantities are based on a max. superelevation of 6.25%)

10/20/2022 8:52:10 AM

FRP BENDING DIAGRAMS

FRP REINFORCING

MARK	SIZE	LENGTH			
		PRECAST COPING FOR SINGLE-SLOPE		C-I-P COPING FOR SINGLE-SLOPE	
		(36")	(42")	(36")	(42")
A	6	5'-3"	5'-5"	7'-10"	8'-0"
B1	5	11'-6"	9'-6"	AS REQD.	AS REQD.
B2	5	AS REQD.	AS REQD.	AS REQD.	AS REQD.
C	6	4'-10"	4'-10"	N/A	N/A
F	6	4'-10"	4'-10"	4'-10"	4'-10"
L	5	4'-5"	4'-5"	4'-5"	4'-5"
P	4	2'-7"	2'-7"	2'-7"	2'-7"
S	5	11'-6"	N/A	AS REQD.	N/A
S	6	N/A	9'-6"	N/A	AS REQD.
T1	5	6'-1"	N/A	6'-1"	N/A
T1	6	N/A	9'-6"	N/A	9'-6"
T2	5	6'-1"	N/A	6'-1"	N/A
T2	6	N/A	6'-1"	N/A	6'-1"
U	7	4'-4"	4'-6"	4'-4"	4'-6"
V1	5	4'-6"	5'-2"	4'-6"	5'-2"
V2	5	4'-3"	4'-8"	4'-3"	4'-8"
V3	5	4'-2"	4'-2"	4'-2"	4'-2"
V4	5	3'-11"	3'-11"	3'-11"	3'-11"
1" Ø Dowel	Smooth Bar	2'-0"	2'-0"	2'-0"	2'-0"

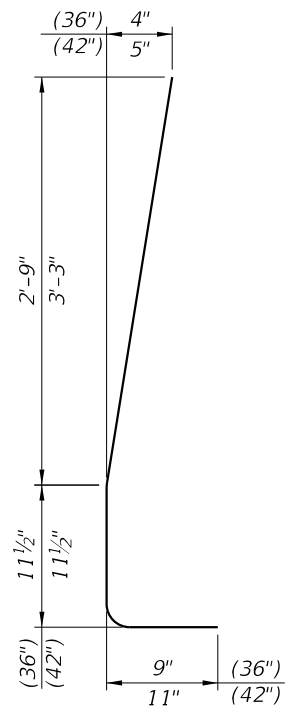

STIRRUP BAR 5V1

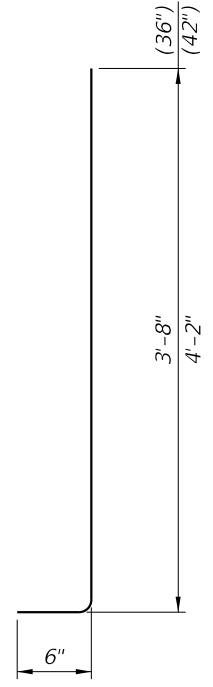

STIRRUP BAR 5V2

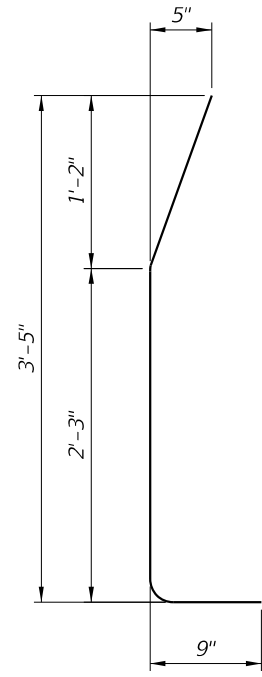

STIRRUP BAR 5V3

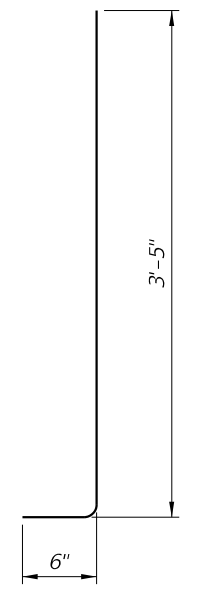

STIRRUP BAR 5V4

GUARDRAIL TRANSITION BARS

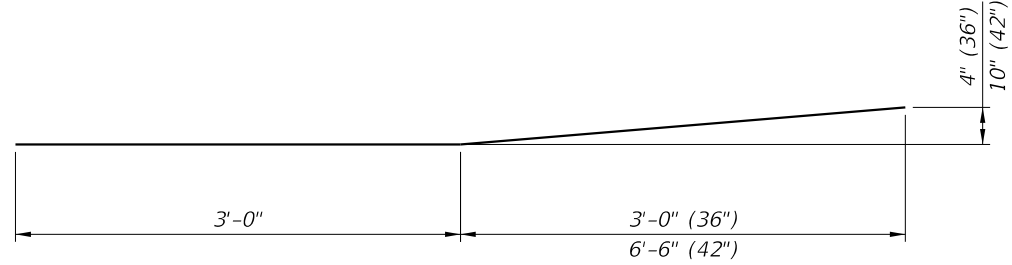

BAR T1

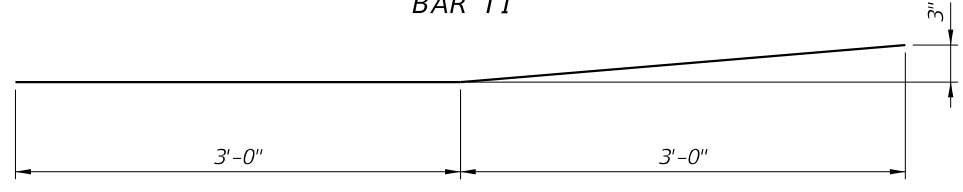

BAR T2

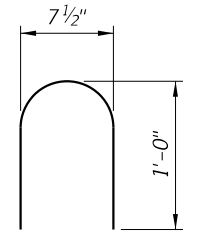

STIRRUP BAR 4P

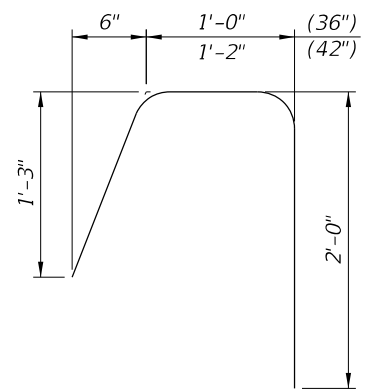

BAR 6U

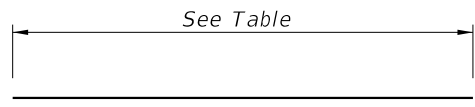

BARS 6A, 5B1, 5B2, 6C, 6F, 5S, & 6S

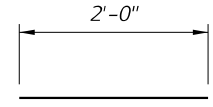

1" Ø DOWEL

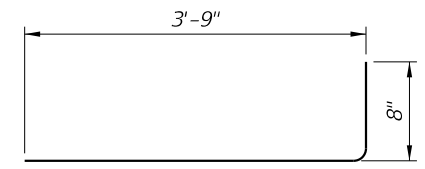

BARS 5L

REINFORCING STEEL NOTES:

1. All bar dimensions in the bending diagrams are out to out.
2. All reinforcing at expansion and open joints will have a 1.5" minimum cover.
3. Lap splices for Bars 5B & 5S will be a minimum of 2'-2".
4. For Precast Copings only, lap splice Bars 6A with Bars 6C. Lap splices will be a minimum of 2'-5".
5. The Contractor may use either full length Bars 7A or lap splice with Bars 6C at Bars 5A for C-I-P Copings.
6. Contractor may use a single #5 stirrup in lieu of two bars for 5P and 5V1.
7. FRP Bars can not be field bent.

10/20/2022 8:52:11 AM

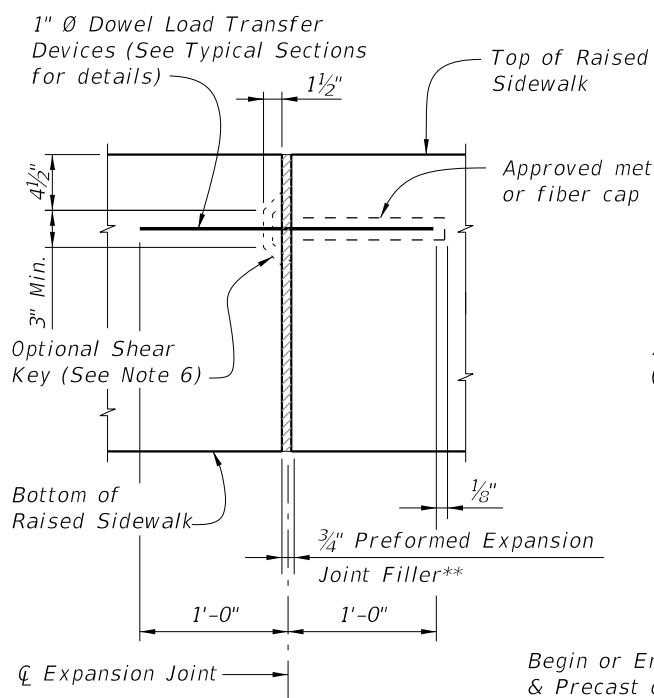

EXPANSION JOINT DETAIL
 (Raised Sidewalk expansion joints are to coincide with 3/4" open joints in Concrete Barrier)

** Stay-In-Place Plastic Preformed Bond Breakers are permitted to form joints.

RAISED SIDEWALK NOTES:

1. When a 42" Vertical Shape is used with a precast coping, increase Bars 4C to Bars 5C or provide Bars 4C @ 4" spacing within 6'-0" of Expansion Joints.
2. Construct the expansion joints, V-Grooves and face of coping plumb.
3. Provide Class II concrete for slightly aggressive environments or Class IV for moderately or extremely aggressive environments.
4. Dowel Load Transfer Devices will be hot-dip galvanized ASTM A 36 smooth round bar, or GFRP smooth round bars with a minimum shear strength of 22 ksi in accordance with ASTM D7617. Install Dowel Load Transfer Devices in accordance with Specification Section 350.
5. Construct 3/4" Expansion Joints in raised sidewalk and C-I-P copings perpendicular or radial to the Gutter Line. Provide at 90'-0" maximum intervals as shown.
6. Shear Keys in Junction Slab are required when GFRP bars are used for Dowel Transfer Devices and are optional with steel dowel bars. Tongue Slope on Shear Key must be constant and between 5° to 45° from horizontal.
7. Provide and install Preformed Expansion Joint Filler in accordance with Specification Section 932.
8. Construct 1/2" V-Grooves in raised sidewalk and C-I-P coping at 30'-0" maximum intervals as shown. Space V-Grooves equally between 3/4" Expansion Joints and/or Begin or End Raised Sidewalk. V-Groove locations are to coincide with V-Groove locations in the Concrete Barrier.
9. Spacing shown is along the Gutter Line.
10. For Precast Coping only, provide Dowel Bars 4D embedded 1'-0" and extend 9" above the top of MSE wall panels. Field cut as necessary to maintain 2" minimum cover to the top of the buildup concrete. See Wall Company Drawings for number and spacing of Dowel Bars 4D.
11. Finish Sidewalks in accordance with Specification Section 522.
12. The following Indexes contain details of the intersection of the retaining wall at approach slabs:
 Index 400-090 - Approach Slabs (Flexible Pavement Approaches)
 Index 400-091 - Approach Slabs (Rigid Pavement Approaches)

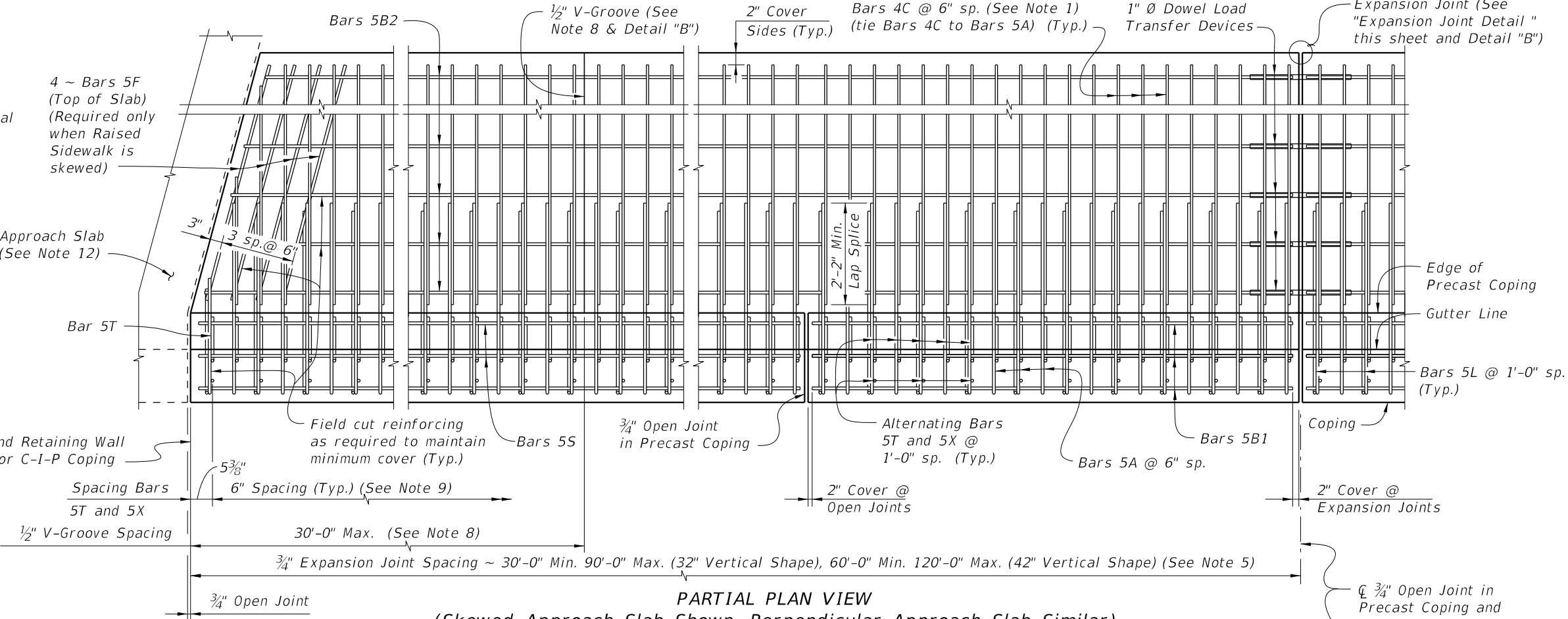

PARTIAL PLAN VIEW
 (Skewed Approach Slab Shown, Perpendicular Approach Slab Similar)
 (Precast Coping Shown, C-I-P Coping Similar) (Concrete Barrier not Shown for Clarity)

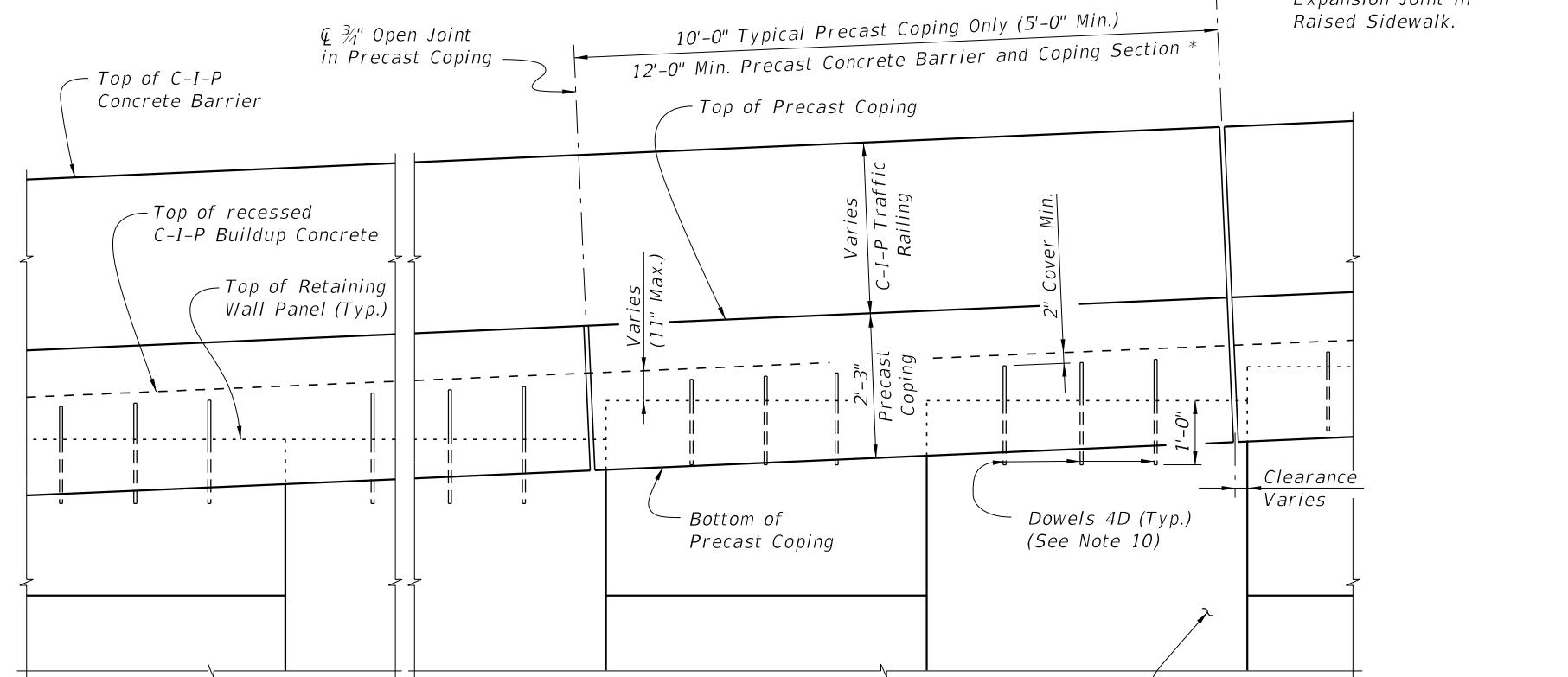

PARTIAL ELEVATION VIEW
 (Precast Coping & Raised Sidewalk Reinforcing not Shown for Clarity)
 (Precast Coping Shown, C-I-P Coping Similar)

Retaining Wall (MSE Wall shown, other types similar)
 * C-I-P End Section must be ≥ 12'-0".

CROSS REFERENCE: For Detail "B", see Sheet 4.

VERTICAL SHAPE

LAST REVISION 11/01/18	DESCRIPTION:		FY 2023-24 STANDARD PLANS	CONCRETE BARRIER/RAISED SIDEWALK - WALL COPING	INDEX	SHEET
					521-620	1 of 4

10/20/2022 8:52:12 AM

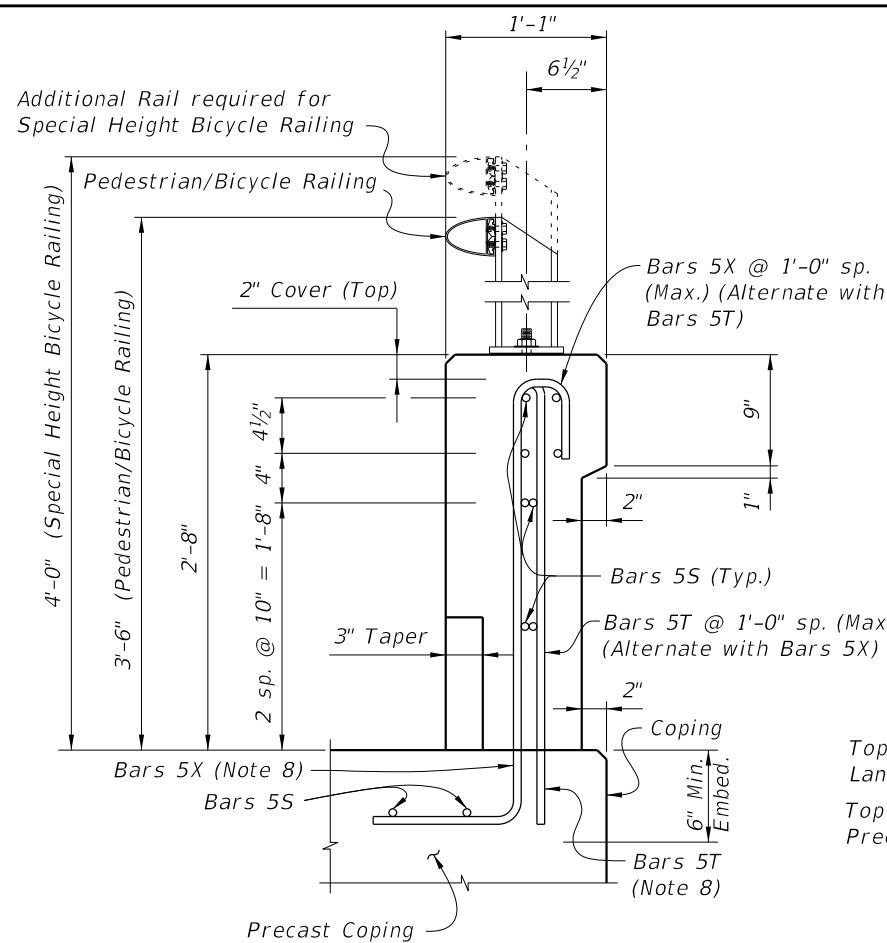

END VIEW OF 32" VERTICAL SHAPE END TRANSITION FOR GUARDRAIL ATTACHMENT (Showing Bars 5S, Bars 5T and Bars 5X) (Precast Coping Shown, C-I-P Coping Similar)

NOTE: See Sheet 4 for End Transition Elevation.

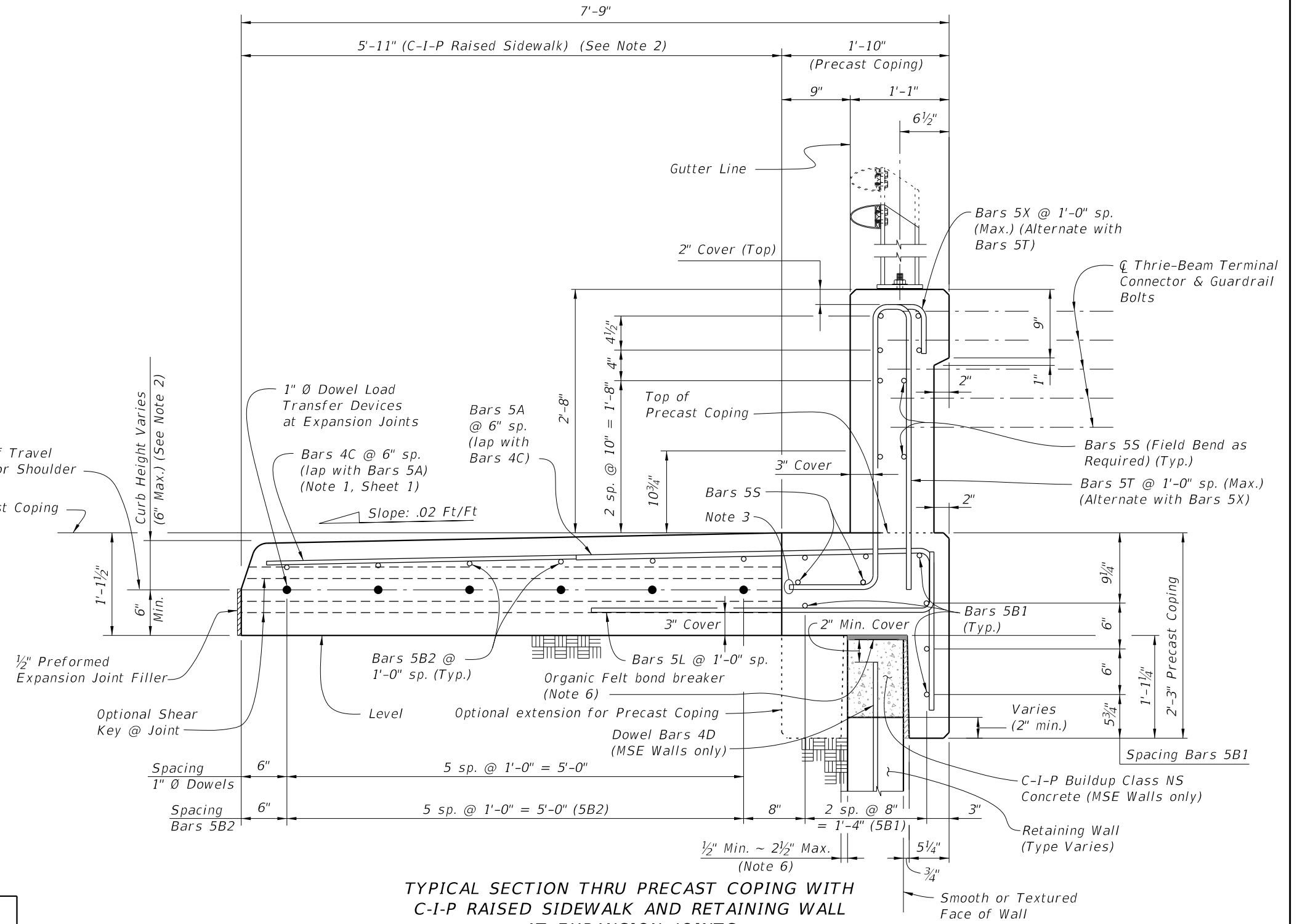

TYPICAL SECTION THRU PRECAST COPING WITH C-I-P RAISED SIDEWALK AND RETAINING WALL AT EXPANSION JOINTS (32" Vertical Shape Shown, 42" Vertical Shape Similar)

- NOTES:
- Actual width varies depending on type of Retaining Wall used.
 - Match roadway curb shape (Type) and height. See Roadway Plans and Index 520-001. 5'-11" dimension is based on a 32" Vertical Shape with a Type D curb adjacent to a 6'-0" wide sidewalk. Adjust this dimension as required for other curb types or transitions at Begin or End Retaining Wall.
 - Trim end of Bars 5T and 5X to clear construction joint for 42" Vertical Shape.
 - At the Contractor's option, mechanical couplers may be used to splice reinforcing. Complete details, including reinforcement lengths are required in the Shop Drawings. Mechanical couplers shall develop 125% of the bar yield strength.
 - Contractor to maintain stability of precast coping prior to junction slab completion.
 - When the air gap between the precast coping extension and retaining wall exceeds 2 1/2", fill gap with full depth Expanded Polystyrene to provide a maximum 2 1/2" air gap.
 - For Bullet Railings, see Index 515-021 and 515-022.
 - Begin placing Railing Bars 5T and 5X at the railing end and proceed toward Retaining Wall to avoid conflict with guardrail bolt holes. If required, adjustments to the bar spacing for Bars 5T and 5X shall be made immediately adjacent to Begin or End Bridge. Cut, shift and rotate Bars 5T and 5X as required to maintain cover in End Transition.

ESTIMATED QUANTITIES FOR PRECAST COPING		
ITEM	UNIT	QUANTITY
Concrete (Precast Coping)	CY/LF	0.095
Concrete (C-I-P Raised Sidewalk)	CY/LF	0.232
Reinforcing Steel (Precast Coping) excluding Bars 5T, 5X and 5S (Typ.)	LB/LF	23.90
Reinforcing Steel (C-I-P Raised Sidewalk) (Typ.)	LB/LF	13.50
Additional Reinf. @ Expansion Joints (Steel Dowels)	LB	32.04

The above concrete quantities are based on a Type D Concrete Curb (See Note 2).

10/20/2022 8:52:13 AM

32" VERTICAL SHAPE

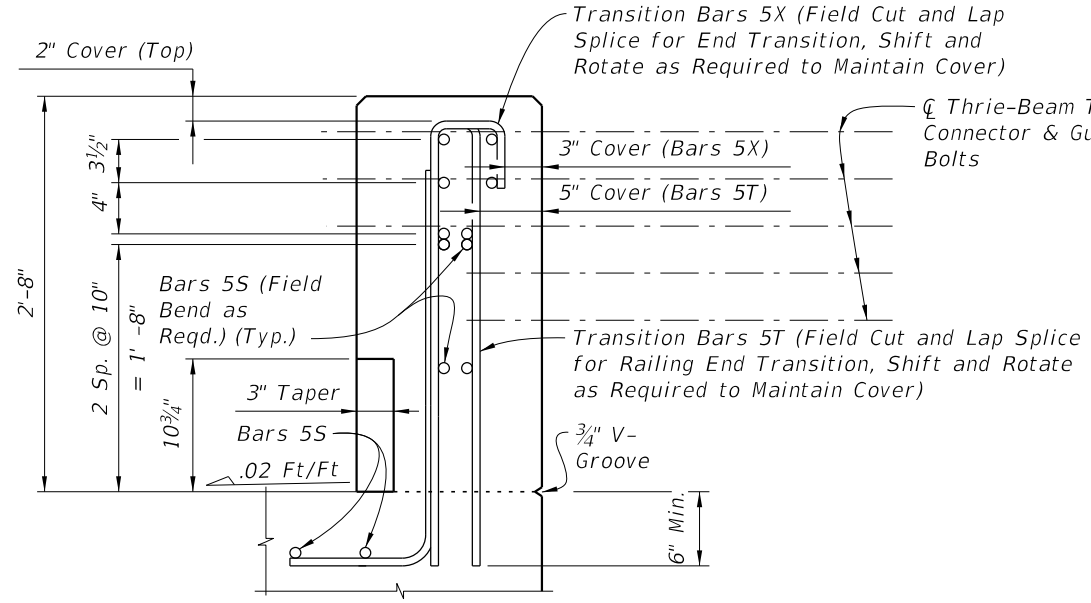

END VIEW OF VERTICAL FACE END TRANSITION

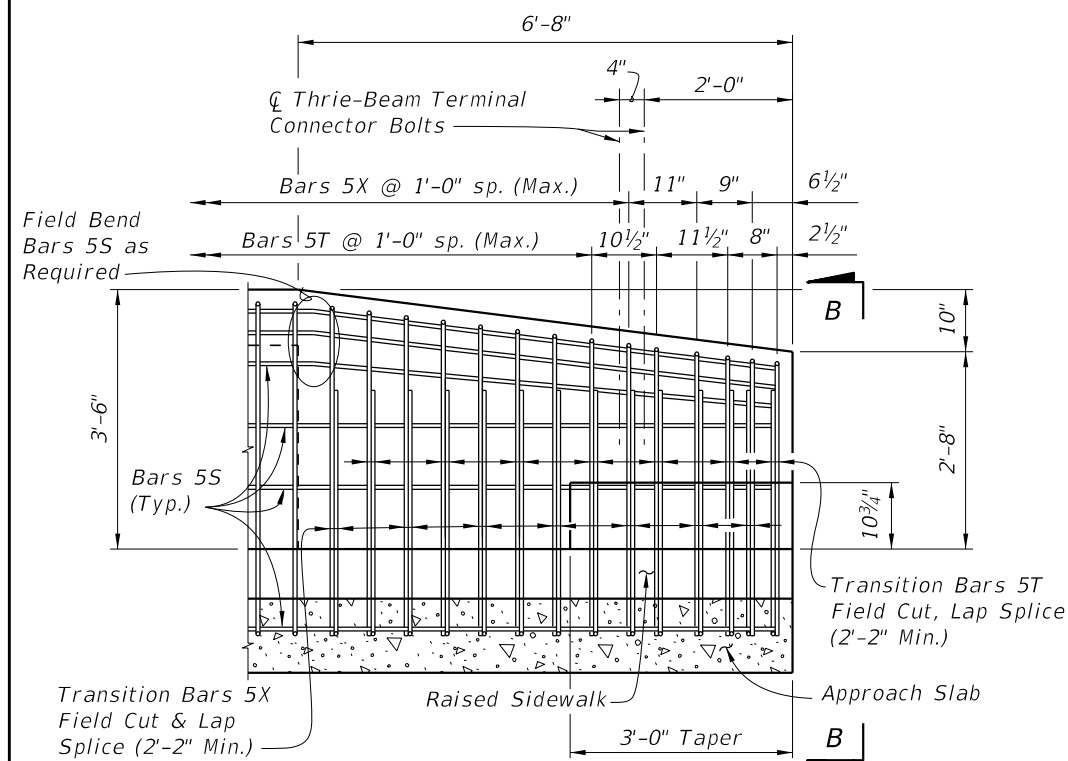

ELEVATION END TRANSITION (Guardrail Not Shown For Clarity)

ESTIMATED QUANTITIES FOR C-I-P COPING		
ITEM	UNIT	QUANTITY
Concrete	CY/LF	0.326
Reinforcing Steel (Typical) excluding Bars 5T, 5X and 5S (Typ.)	LB/LF	35.38
Additional Reinf. @ Expansion Joints (Steel Dowels)	LB	32.04

The above concrete quantities are based on a Type D Concrete Curb on a level Retaining Wall (See Note 1).

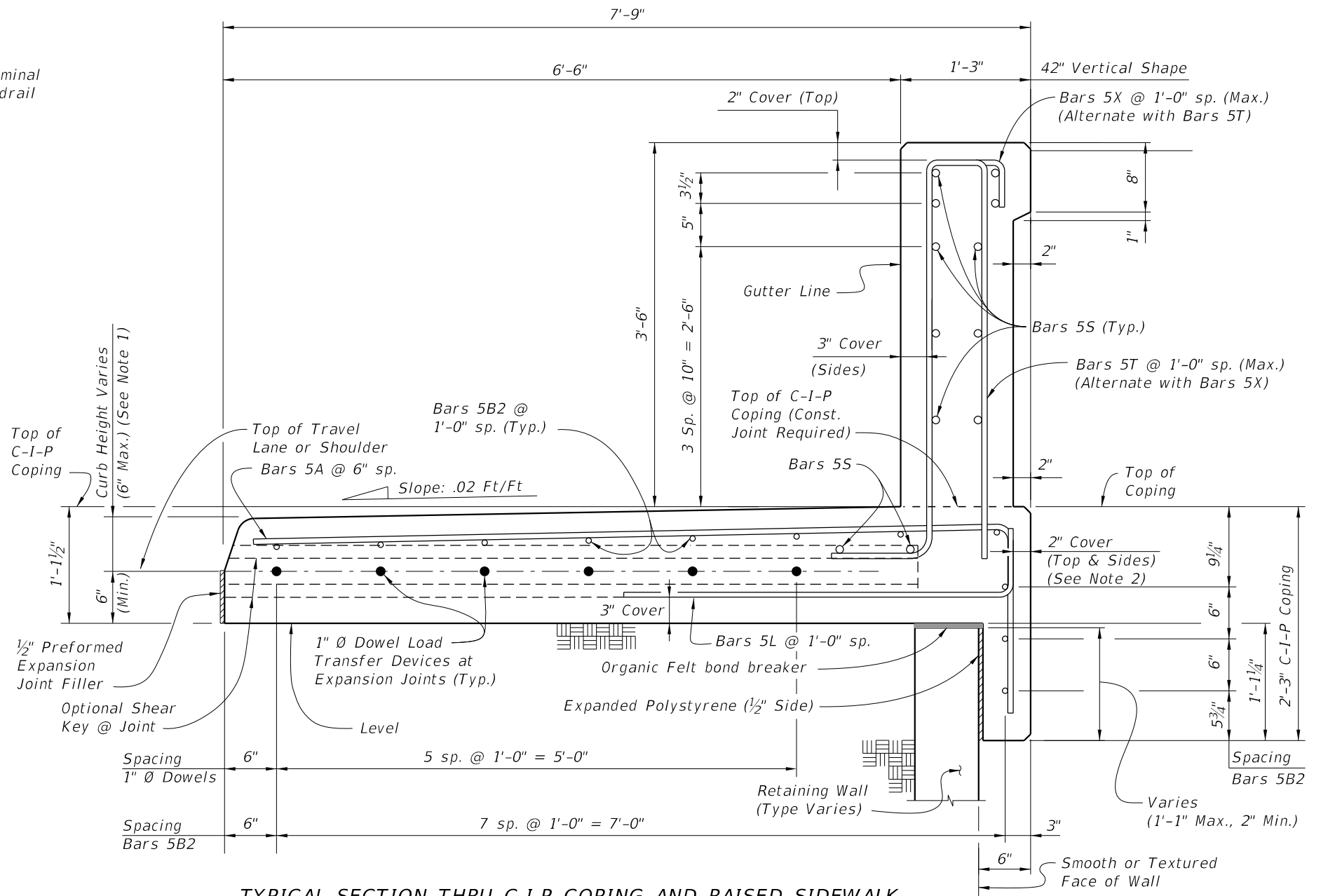

TYPICAL SECTION THRU C-I-P COPING AND RAISED SIDEWALK AND RETAINING WALL AT EXPANSION JOINTS (42" Vertical Face Shown, 32" Vertical Face Similar)

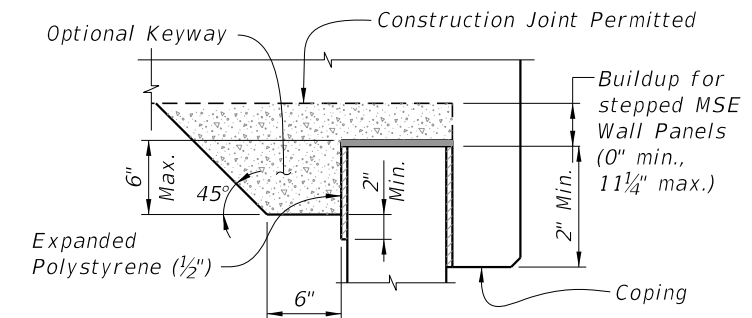

BUILDUP FOR STEPPED MSE WALL PANELS AND C-I-P COPING

- NOTES:
- Match roadway curb shape (Type) and height. See Roadway Plans and Index 520-001. 6'-6" dimension is based on a 42" Vertical Shape with a Type D curb adjacent to a 6'-0" wide sidewalk. Adjust this dimension as required for other curb types or transitions at Begin or End Retaining Wall.
 - If slip forming is used, submit shop drawings for approval showing 3" side cover with the Typical Section dimensions adjusted.
 - Begin placing Railing Bars 5T and 5X at the railing end and proceed toward Retaining Wall to avoid conflict with guardrail bolt holes. If required, adjustments to the bar spacing for Bars 5T and 5X shall be made immediately adjacent to Begin or End Retaining Wall. Cut, shift and rotate Bars 5T and 5X as required to maintain cover in End Transition.

42" VERTICAL SHAPE

10/20/2022 8:52:14 AM

CONVENTIONAL REINFORCING STEEL BENDING DIAGRAMS

BILL OF REINFORCING STEEL			
MARK	SIZE	LENGTH	
		PRECAST COPING/RAILING	C-I-P COPING
A	5	5'-11"	9'-1"
B1	5	9'-6"/11'-6"	N/A
B2	5	AS REQD.	AS REQD.
C	4	5'-5"	N/A
F	5	5'-0"	5'-0"
L	5	4'-5"	4'-5"
1" Ø Dowel	Smooth Bar	2'-0"	2'-0"
		32"	42"
T	5	7'-4"	9'-2"
X	5	5'-1"	6'-0"

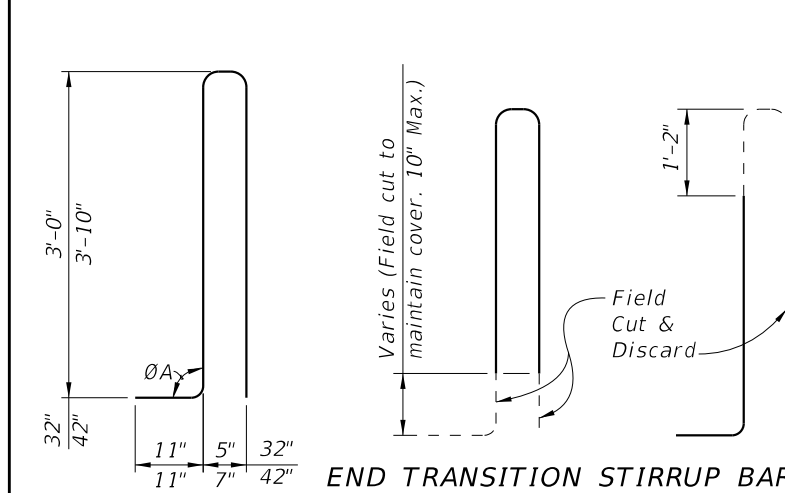
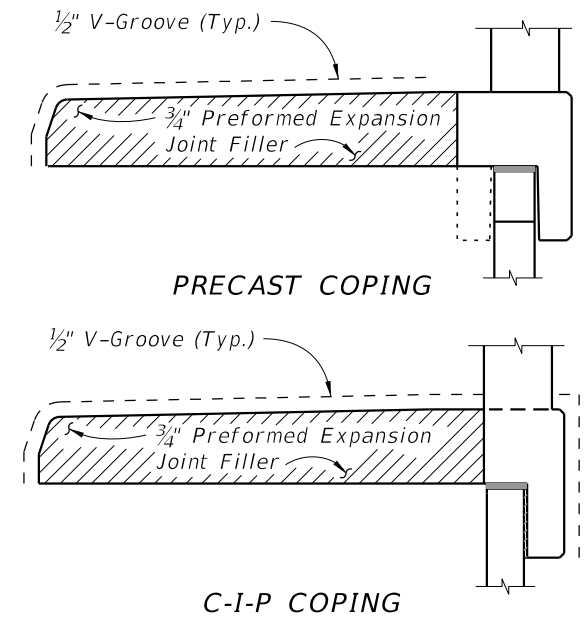
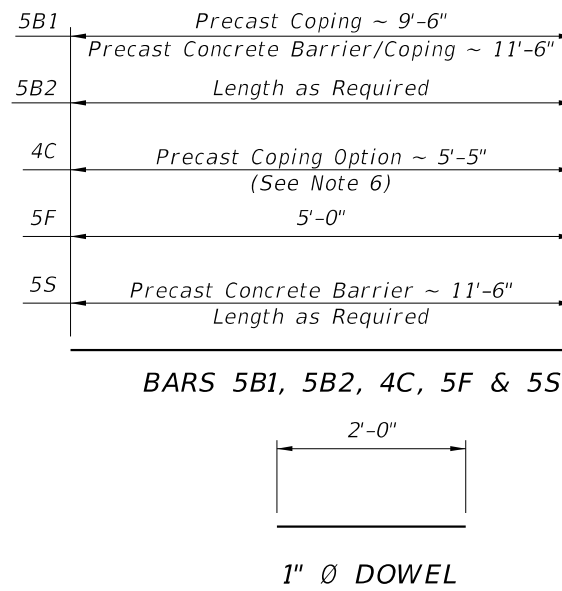
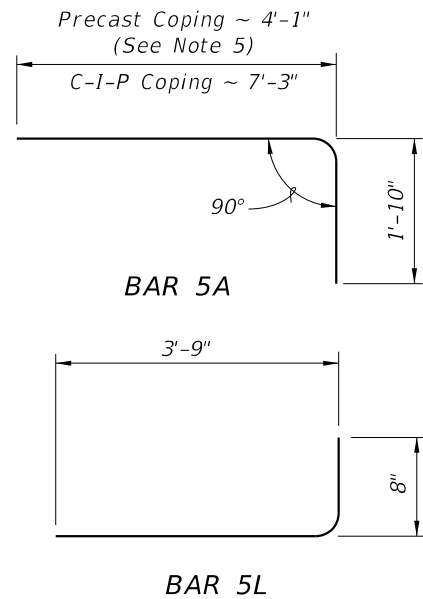

END TRANSITION STIRRUP BARS 5T FOR 42"

To Be Field Cut (7 of each required per Railing End Transition)

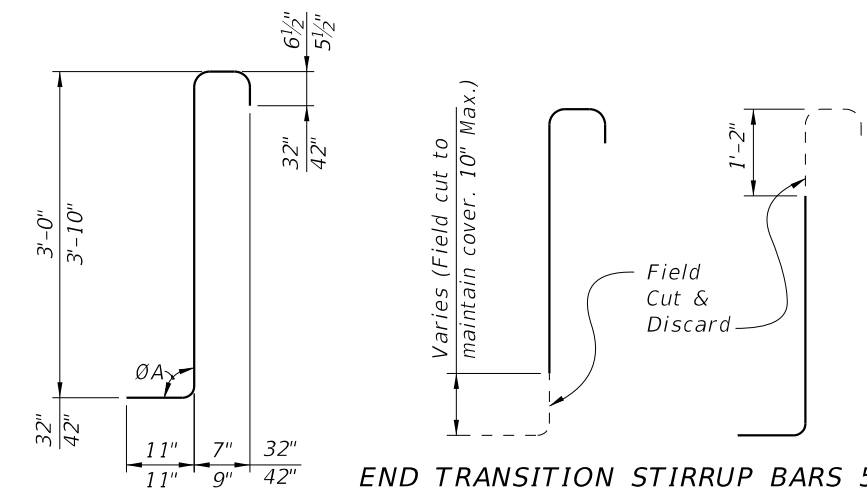

END TRANSITION STIRRUP BARS 5X FOR 42"

To Be Field Cut (7 of each required per Railing End Transition)

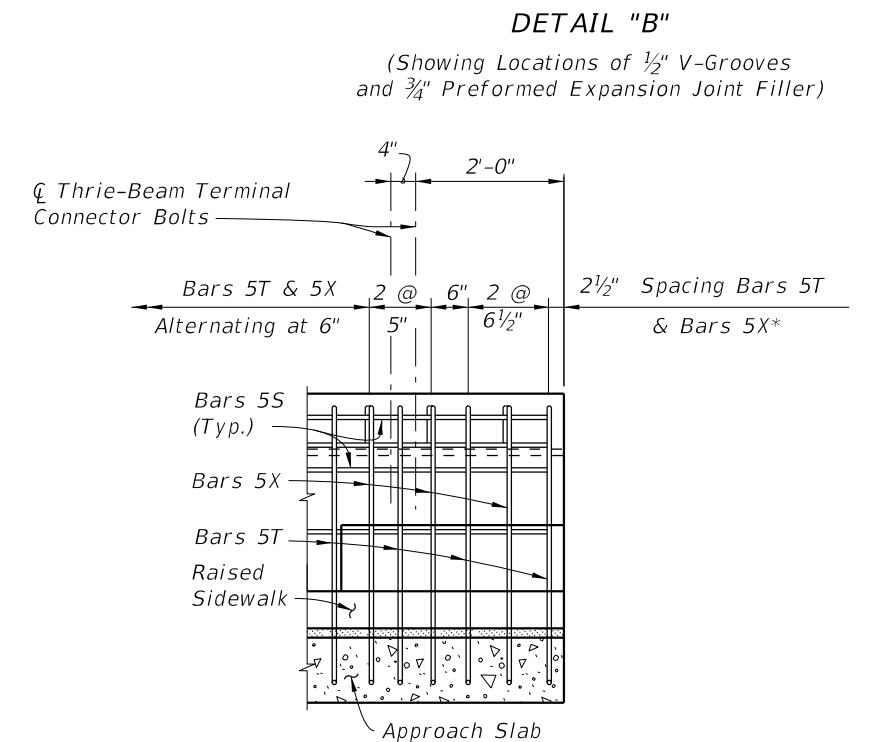

END TRANSITION ELEVATION FOR 32" VERTICAL SHAPE (Guardrail Not Shown For Clarity)

STIRRUP BAR 5T

REINFORCING STEEL NOTES:

1. All bar dimensions in the bending diagrams are out to out.
2. All reinforcing steel at expansion joints will have a 2" minimum cover.
3. Lap splices for Bars 5B and 5S will be a minimum of 2'-2".
4. Lap splice Bars 5A with Bars 4C will be a minimum of 2'-2".
5. Dimension shown is for lap splice option. For mechanical coupler option, this dimension is 1'-8".
6. Dimension shown is for lap splice option. For mechanical coupler option, this dimension is 5'-8", and reinforcing size must be increased to #5 bars (Bars 5C).
7. The Contractor may use deformed WWR when approved by the Engineer. WWR must meet the requirements of Specification Section 931.

* See Sheet 3 Note 3.

ESTIMATED CONCRETE BARRIER QUANTITIES			
ITEM	UNIT	QUANTITY	
		32"	42"
Concrete	CY/LF	0.095	0.145
Reinforcing Steel	LB/LF	23.38	28.33

VERTICAL SHAPE

LAST REVISION 11/01/18	REVISION	DESCRIPTION:		FY 2023-24 STANDARD PLANS	CONCRETE BARRIER/RAISED SIDEWALK - WALL COPING	INDEX 521-620	SHEET 4 of 4
---------------------------	----------	--------------	--	--------------------------------------	---	-------------------------	------------------------

10/20/2022 8:52:15 AM

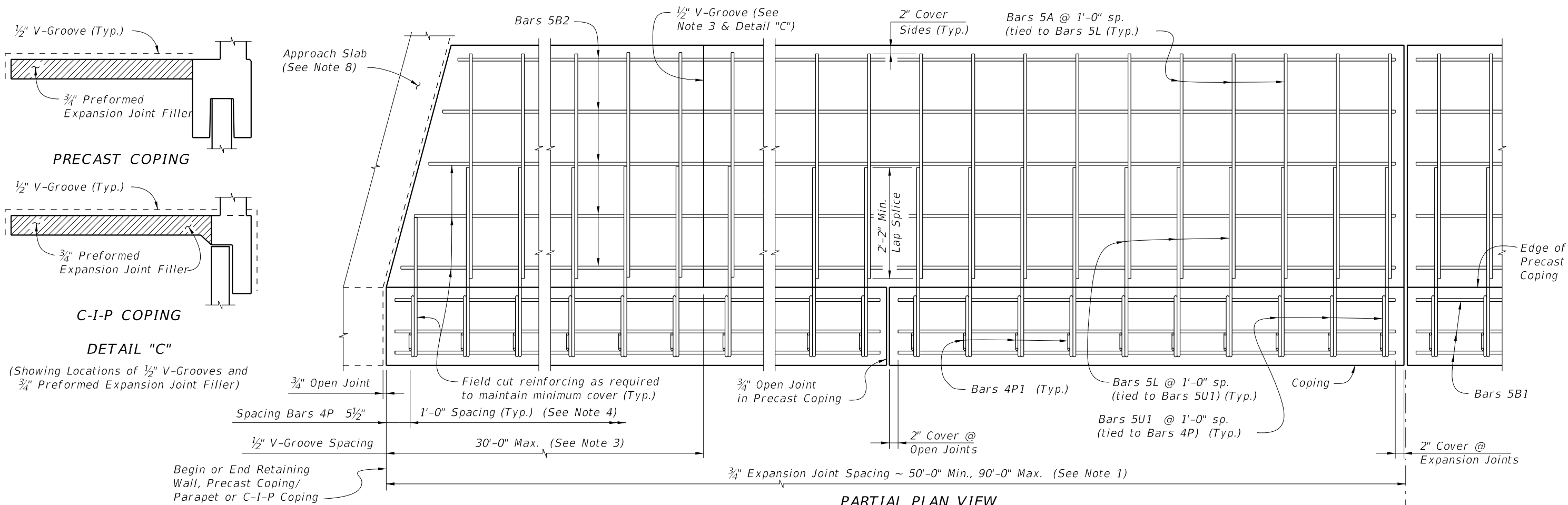

PARTIAL PLAN VIEW
 (Skewed Approach Slab Shown, Perpendicular Approach Slab Similar)
 (Precast Coping Shown, C-I-P Coping Similar) (Concrete Parapet not Shown for Clarity)

PRECAST COPING/PARAPET AND SIDEWALK NOTES:

1. Provide Class II concrete for slightly aggressive environments or Class IV for moderately or extremely aggressive environments.
2. Construct $\frac{3}{4}$ " Expansion Joints in sidewalk and C-I-P coping plumb and either perpendicular or radial to the Gutter Line. Provide Expansion Joints at 90'-0" maximum intervals as shown.
3. Provide and install Preformed Expansion Joint Filler in accordance with Specification Section 932.
4. Construct $\frac{1}{2}$ " V-Grooves in sidewalk and C-I-P coping. Space V-Grooves at 30'-0" Maximum intervals equally spaced between $\frac{3}{4}$ " Expansion Joints and/or Begin or End Sidewalk. For C-I-P Coping only, V-Groove locations are to coincide with V-Groove locations in the Concrete Parapet.
5. Spacing shown is along the Gutter Line.
6. For Precast Coping only, provide Dowel Bars 4D embedded 1'-0" and extend 11" above the top of MSE wall panels. Field cut as necessary to maintain 2" minimum cover to the top of the buildup concrete. See Wall Company Drawings for number and spacing of Dowel Bars 4D.
7. Work this Index with Index 521-001 - Concrete Barrier Wall
8. For C-I-P Coping only, work this Index with Index 521-820 - Pedestrian/Bicycle Railing, or Index 521-825 - 42" Concrete Pedestrian/ Bicycle Railing.
9. Finish Sidewalks in accordance with Specifications Section 522.
10. The following Indexes contain details of the intersection of the retaining wall at approach slabs:
 Index 400-090 - Approach Slabs (Flexible Pavement Approaches)
 Index 400-091 - Approach Slabs (Rigid Pavement Approaches)

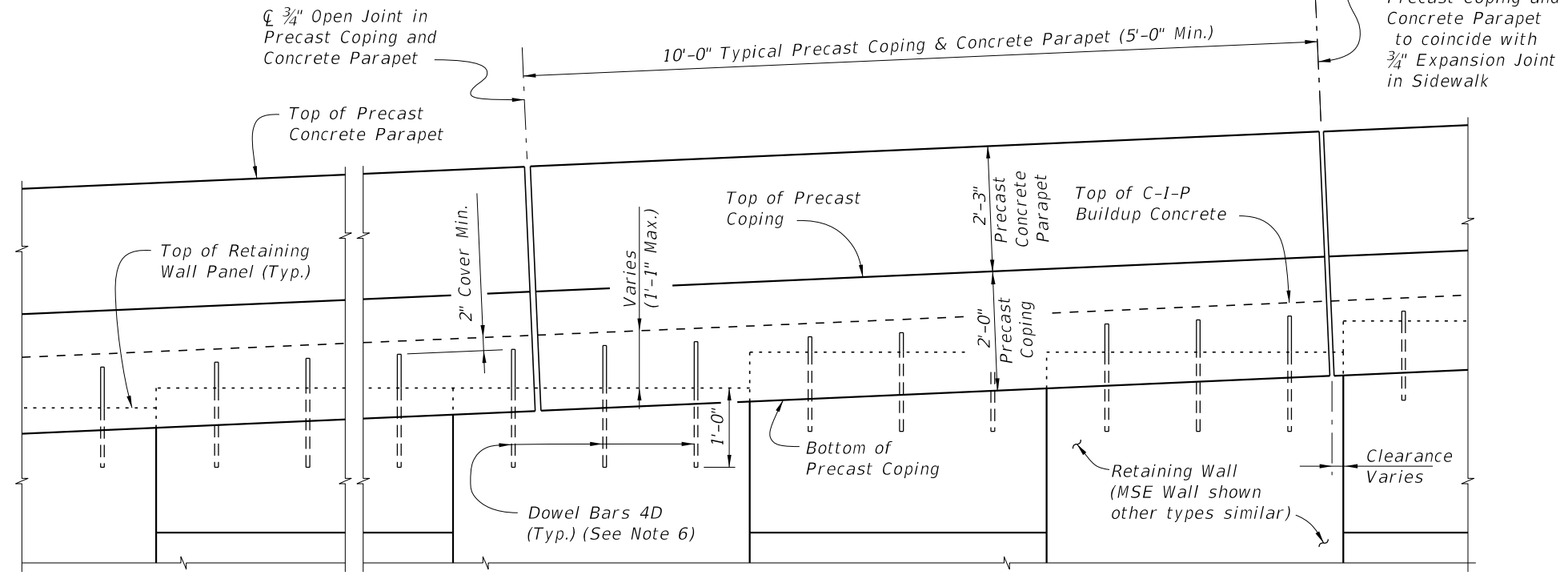

PARTIAL ELEVATION VIEW
 (Precast Coping and Sidewalk Reinforcing not Shown for Clarity)
 (Precast Coping Shown, C-I-P Coping Similar)

10/20/2022 8:52:16 AM

LAST REVISION 11/01/17	DESCRIPTION:	 FY 2023-24 STANDARD PLANS	PARAPET WITH C-I-P SIDEWALK - WALL COPING	INDEX 521-630	SHEET 1 of 2
---------------------------	--------------	--	--	-------------------------	------------------------

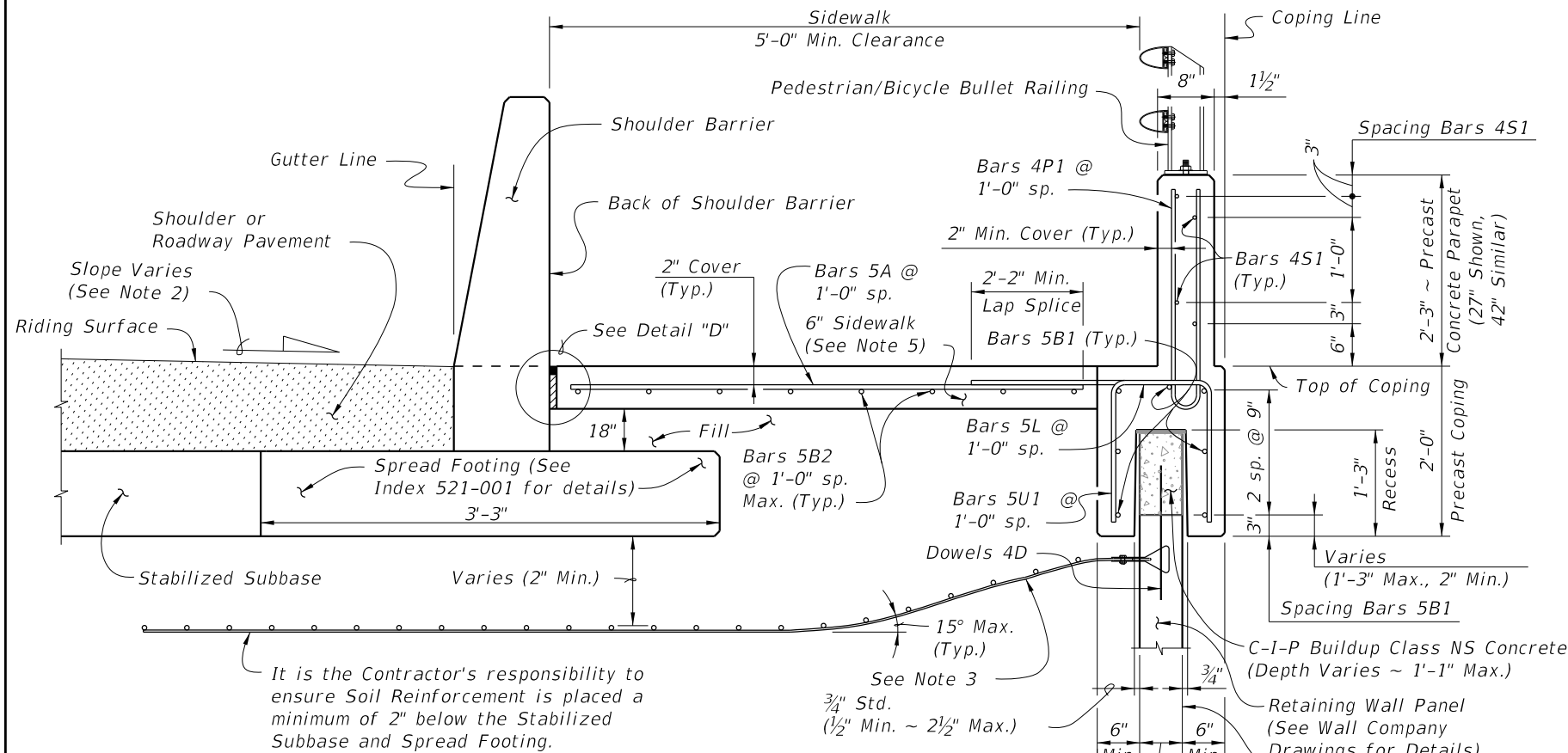

TYPICAL SECTION THRU PRECAST COPING/PARAPET WITH C-I-P SIDEWALK AND RETAINING WALL (MSE Wall Shown, other Wall Types Similar)

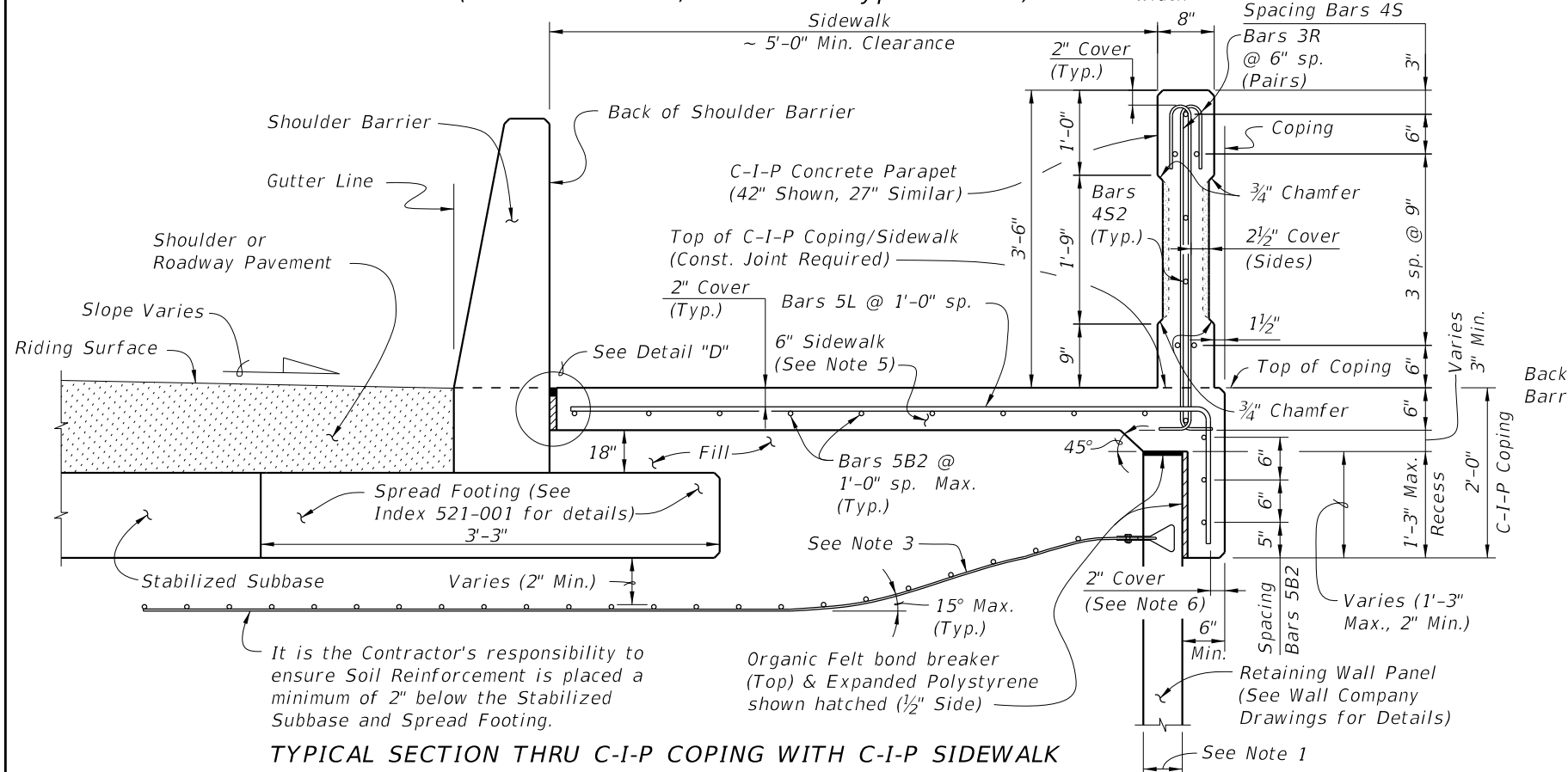

TYPICAL SECTION THRU C-I-P COPING WITH C-I-P SIDEWALK AND RETAINING WALL (MSE Wall Shown, other Wall Types Similar)

REINFORCING STEEL BENDING DIAGRAMS - COPING/PARAPET AND SIDEWALK

BILL OF REINFORCING STEEL			
MARK	SIZE	LENGTH	
		PRECAST COPING	C-I-P COPING
A	5	VARIABLES	N/A
B1	5	9'-6"	N/A
B2	5	AS REQD.	AS REQD.
D	4	2'-0"	N/A
L	5	VARIABLES	VARIABLES
P1	4	5'-5"	5'-5"
S1	4	9'-6"	AS REQD.
S2	4	9'-6"	AS REQD.
R	3	5'-2"	5'-2"
U1	5	VARIABLES	N/A

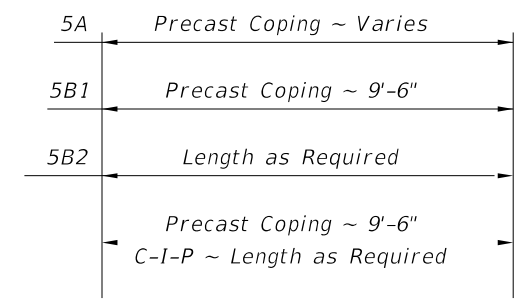

BARS 5A, 5B1, 5B2, 4S1 & 4S2

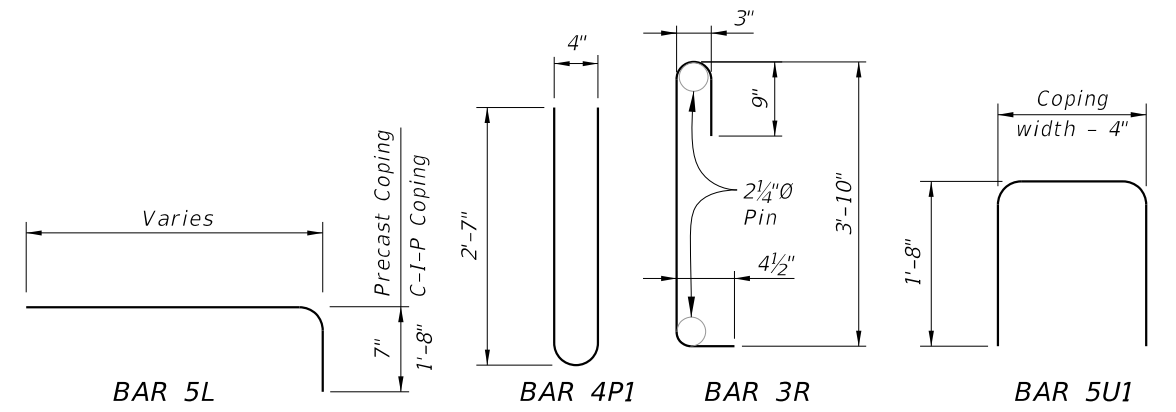

REINFORCING STEEL NOTES:

1. All bar dimensions in the bending diagrams are out to out.
2. All reinforcing steel at expansion joints will have a 2" minimum cover.
3. Lap splices for Bars 5B2 and 5S will be a minimum of 2'-2".
4. For Precast Coping only, lap splice Bars 5L with Bars 5A. Lap splices will be a minimum of 2'-2".
5. The Contractor may use Deformed WWR when approved by the Engineer. WWR must meet the requirements of Specification Section 931.

PRECAST COPING/PARAPET AND SIDEWALK NOTES:

1. Actual width varies depending on type of Retaining Wall used.
2. Place or cast Concrete Parapet vertical.
3. Gradually deflect/displace Soil Reinforcement downward as required. Soil Reinforcement is shown deflected downward for illustrative purposes only and is not to scale. See Wall Company Drawings for details.
4. Complete details and dimensions of Concrete Pedestrian/Bicycle Railing are required in the Shop Drawings.
5. Match cross slope of connecting sidewalk or as shown in the Wall Control Drawings.
6. If slip forming is used, submit shop drawings for approval showing 2 1/2" side cover with adjusted Typical Section dimensions.
7. Bullet Railing: See Indexes 515-021 and 515-022.

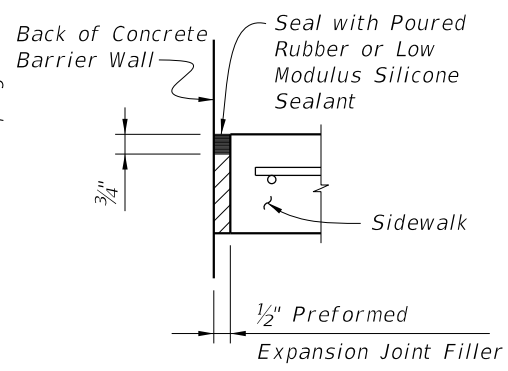

DETAIL "D"

10/20/2022 8:52:17 AM

REINFORCING STEEL BENDING DIAGRAMS - DRAINAGE

BILL OF REINFORCING STEEL			
MARK	REQD.	SIZE	LENGTH
S2	16	4	3'-1"
S3	2	5	10'-0"
U2	11	5	VARIES
U3	4	5	12'-10"

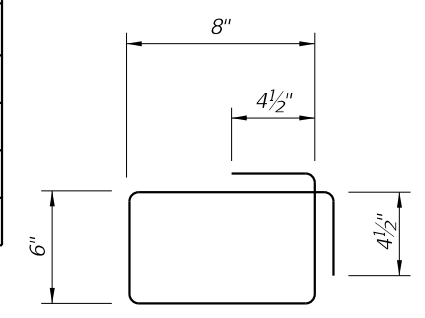

STIRRUP BAR 4S2

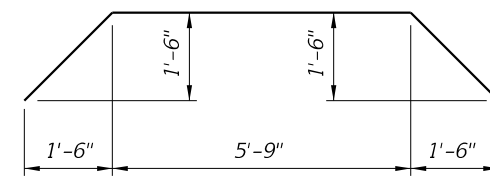

BAR 5S3

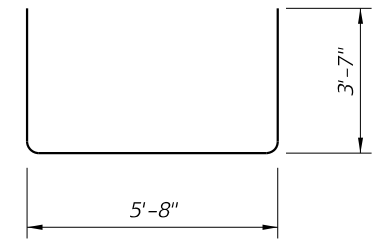

BAR 5U3

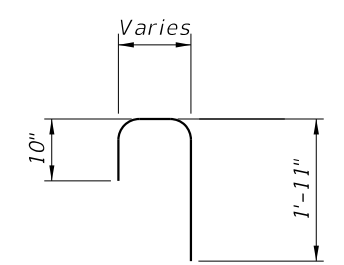

BAR 5U2

REINFORCING STEEL NOTES:

1. All bar dimensions in the bending diagrams are out to out.
2. All reinforcing steel at open joints will have a 2" minimum cover.
3. See Index 521-610, 521-620 & 521-630 for Bars 5A, 5B, 5C and 5L.
4. The Contractor may use Welded Wire Reinforcement (WWR) when approved by the Engineer. WWR must consist of Deformed wire meeting the requirements of Specification Section 931.

NOTES:

1. Spacing shown is along the Gutter Line. Spacing shown is for C-I-P Junction Slab. For C-I-P Raised Sidewalks or Sidewalks, match bar spacing and size shown in Typical Sections (i.e., 11 ~ Bars 5U2 and 15 ~ Bars 4S2 @ 6" spacing for Raised Sidewalks).
2. Dimensions shown are for junction slab. Increase width as required for C-I-P Raised Sidewalk and Sidewalks.
3. Actual location & width vary depending on type of Retaining Wall used.
4. See Index 521-610 for Bars 4V1 or 5V1 and 5B1.
5. Organic Felt bond breaker (Top) & Expanded Polystyrene shown hatched (1/2" Side).
6. Locate \bar{C} Barrier Wall Inlet a minimum of 10'-0" away from \bar{C} Expansion Joints in Junctions Slab, Raised Sidewalk or Sidewalk, C-I-P Coping and Traffic Railing or Concrete Parapet.
7. Locate open joints in Barrier Wall and Coping a minimum of 5'-0" from the centerline of the Barrier Wall Inlet.
8. Work this Index with the following as appropriate:
Index 521-610
Index 521-620
Index 521-630

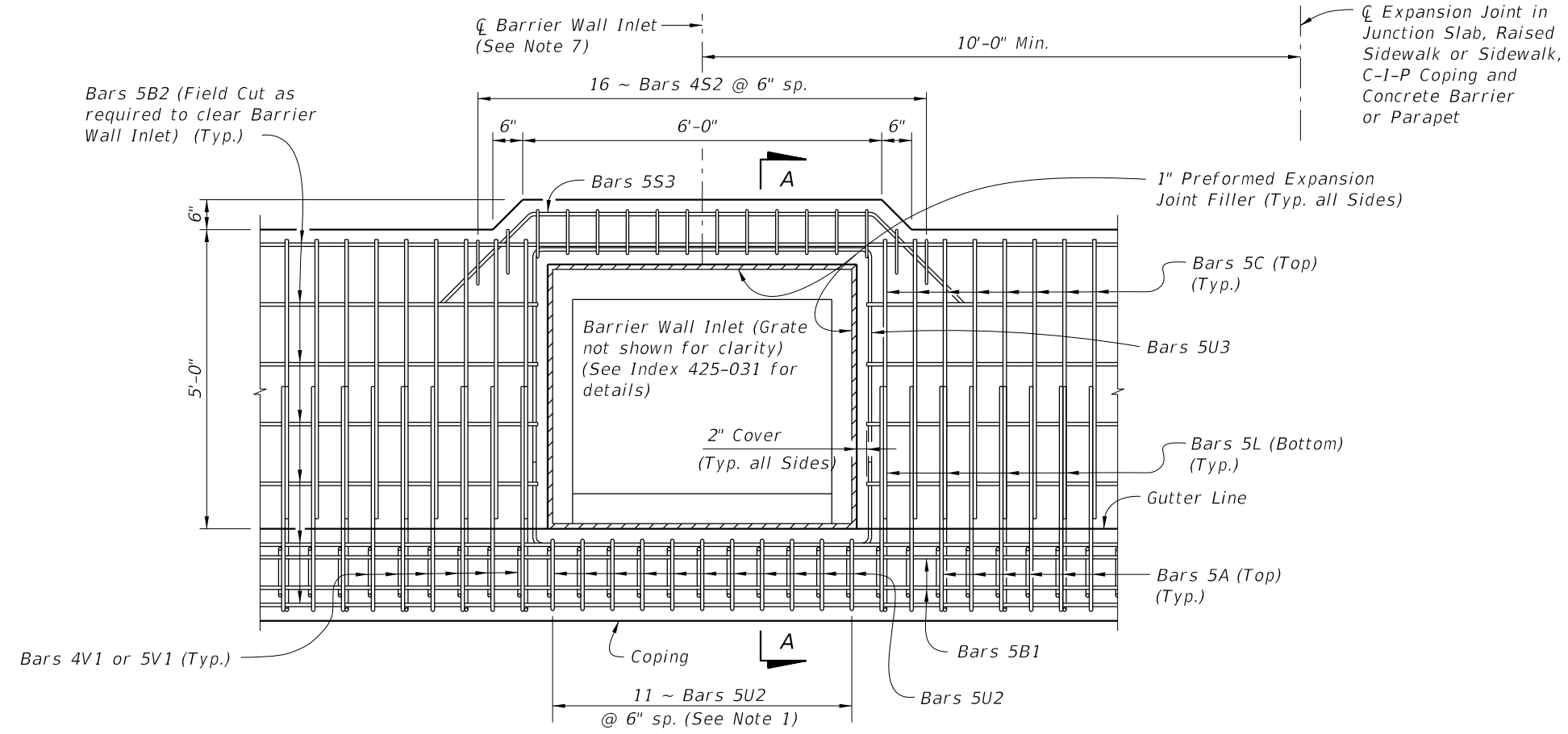

PLAN VIEW
(Junction Slab Shown, Raised Sidewalk Similar)

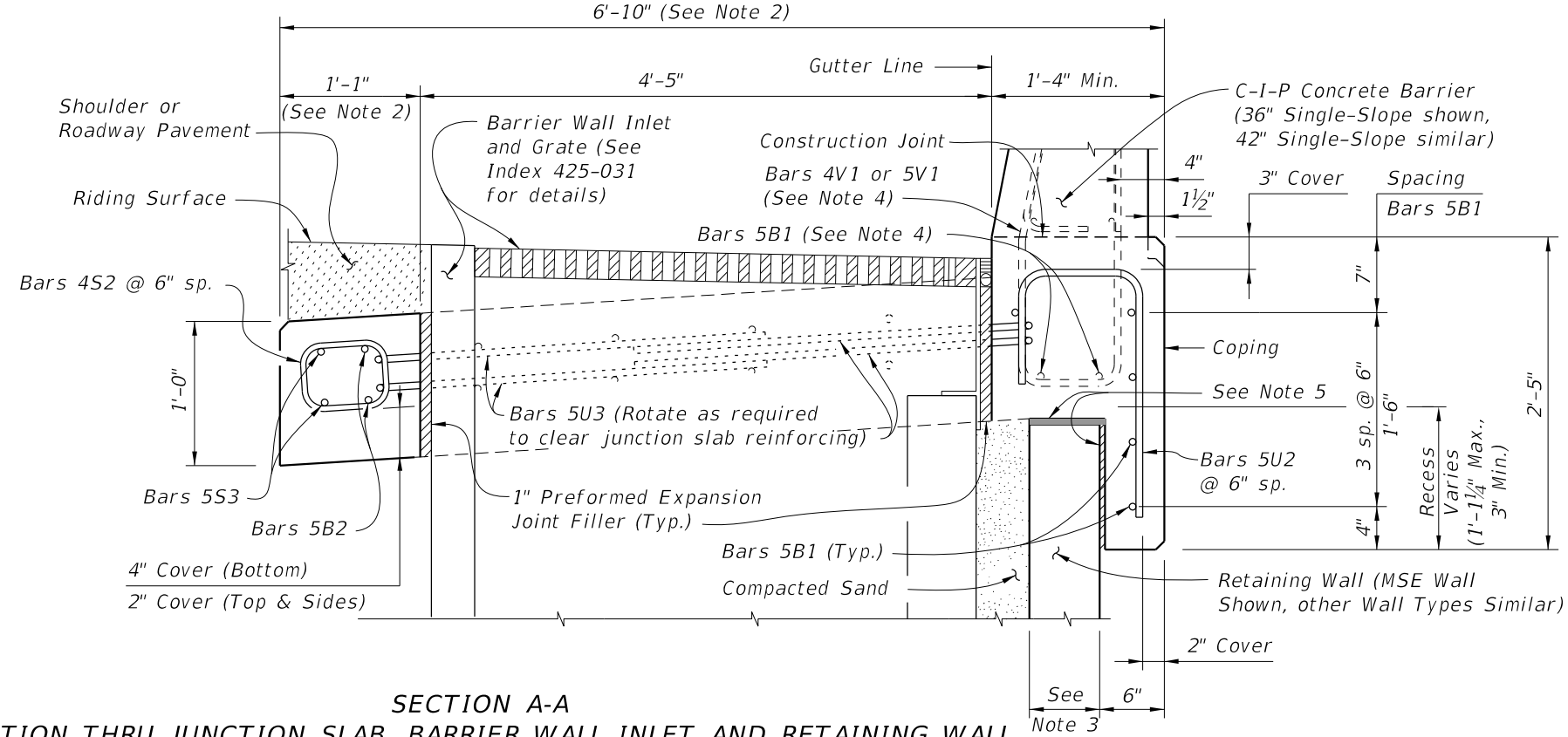

SECTION A-A
SECTION THRU JUNCTION SLAB, BARRIER WALL INLET AND RETAINING WALL
(Junction Slab Shown, Raised Sidewalk Similar)

10/20/2022 8:52:18 AM

LAST REVISION 11/01/19	DESCRIPTION:		FY 2023-24 STANDARD PLANS	DRAINAGE INLET OPENINGS IN JUNCTION SLAB - WALL COPING	INDEX	SHEET
					521-640	1 of 1

LIGHT POLE PEDESTAL NOTES:

- ANCHOR BOLTS:**
Anchor Bolt design is based on the standard Roadway Aluminum Light Pole configurations shown on Index 715-002 with top of pedestal 75' or less above ground or MLW.
Anchor Bolt Diameter: See Table 1
- MATERIALS:**
Anchor Bolts: ASTM F1554 Grade 55.
Nuts: ASTM A563 Grade A, Heavy-Hex.
Washers: ASTM F436 Type 1.
Anchor Plate: ASTM A709 (Grade 36) or ASTM A36.
Coating: Galvanize all Nuts, Bolts Washers, and plates in accordance with ASTM F2329.
- The Contractor is responsible for ensuring the anchor bolt design is compatible with the light pole base plate. Modifications to the anchor bolt design shown must be signed and sealed by the Contractor's Specialty Engineer and submitted to the Engineer for approval prior to construction.
- Install Anchor Bolts plumb.
- For conduit, EJB and expansion/deflection fitting details, see Utility Conduit Detail Drawings and Index 630-010.
- The cost of anchor bolts, nuts, washers and anchor plates will be included in the Bid Price for Light Poles. Include the cost of all labor, concrete and reinforcing steel required for construction of the pedestals, and miscellaneous hardware required for the completion of the electrical system in the Bid Price for either the Concrete Barrier or Concrete Parapet that the pedestal is behind.
- Field Cut Bars 4M2 as required to maintain clearance.
- Slip Forming Method of construction requires the Engineer's approval within the limits shown.
- Reinforcing shown for light pole pedestals is in addition to typical reinforcing for Junction Slabs and Raised Sidewalks.
- Work this Index with the following as appropriate:
Index 521-512
Index 521-610
Index 521-620
Index 521-630
- Pedestal may be precast in one section with Coping. Minimum Precast Coping section length is 10 ft. or 12 ft for combination Precast Concrete Barrier and Coping section.
- For Estimated Quantities, see Sheet 3.
- Unless otherwise noted, Concrete Barrier (36" Single-Slope) is shown in all Views and Sections. The Pedestal details for other Concrete Barriers or pedestrian/bicycle railings are similar.

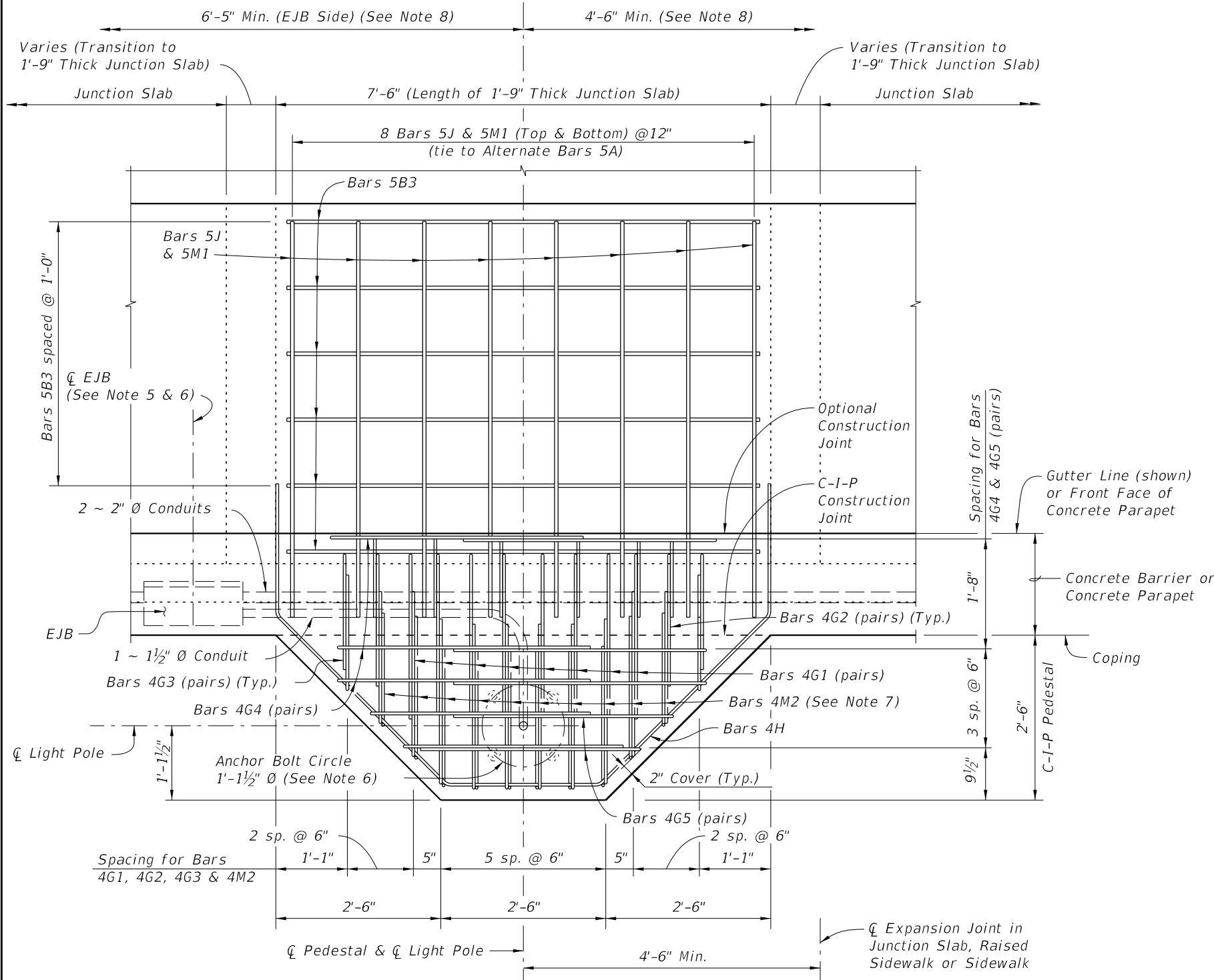

PLAN VIEW
(Junction Slab reinforcing not shown for clarity)
(Junction Slab Shown, Raised Sidewalk or Sidewalk Similar)

TABLE 1 DESIGN LIMITATION FOR ANCHOR BOLTS (1" Dia.)

Wind Speed (MPH)	Arm Length (FT)	BASE OF POLE HEIGHT*		
		40 ft.	45 ft.	50 ft.
120	ALL	75	75	75
140	ALL	75	75	75
160	8 & 10	75	75	45**
160	12 & 15	75	75	25**

* Above Natural Ground
** Use 1 1/4" Ø Anchor bolts for wall heights greater than the height shown and less than 75'.

11/30/2022 9:32:16 AM

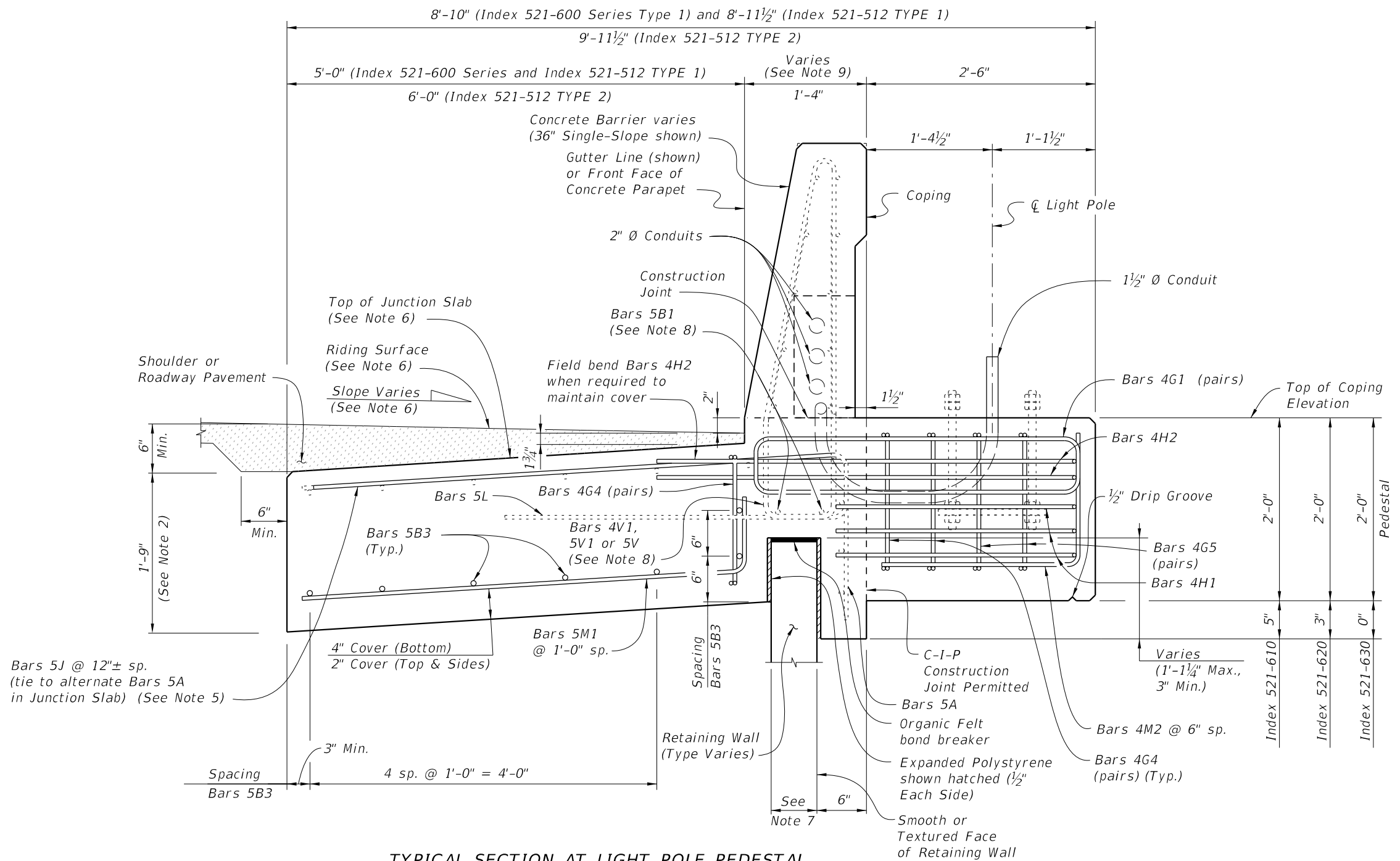

TYPICAL SECTION AT LIGHT POLE PEDESTAL
 (Junction Slab Shown, Raised Sidewalk or Sidewalk Similar) (36" Single-Slope Concrete Barrier shown, other railings similar)

- NOTES:**
1. Provide Concrete Class to match adjacent coping.
 2. For junction slabs, increase the 1'-0" depth dimension to 1'-9".
 3. For Parapet with sidewalk see Index 521-630, but increase 6" sidewalk depth to 1'-6". For raised sidewalk see Index 521-620.
 4. The minimum length of the Junction Slabs, raised sidewalks and sidewalks is 30'-0", measured along the Gutter Line.
 5. Bars 4J are only required when pedestals are behind a Concrete Barrier or Concrete Barrier/ Noise Wall.
 6. Top of junction slab may be thickened to match finished grade of concrete pavement or shoulder, or top of sidewalk or raised sidewalk (See Notes 3 & 4).
 7. Actual width varies depending on type of retaining wall used.
 8. See Index 521-610 for Bars 4V1, 5V1 and 5B, or Index 521-512 for Bars 5V and 5B1.
 9. Work with Index 521-512 (Concrete Barrier/ Noise Wall), Index 521-610 (Single-Slope), Index 521-620 (Vertical Shape), and Index 521-630 (Concrete Parapet).

10/20/2022 8:52:20 AM

LAST REVISION 11/01/17	REVISION	DESCRIPTION:		FY 2023-24 STANDARD PLANS	LIGHT POLE PEDESTAL - WALL COPING	INDEX 521-650	SHEET 2 of 3
---------------------------	----------	--------------	--	-------------------------------------	--	-------------------------	------------------------

REINFORCING STEEL BENDING DIAGRAMS - LIGHT POLE PEDESTAL

BILL OF REINFORCING STEEL

MARK	SIZE	NO. REQD.	LENGTH
B3	5	7	7'-2"
G1	4	16	5'-8"
G2	4	4	4'-8"
G3	4	4	4'-2"
G4	4	6	8'-10"
G5	4	4	7'-4"
H1	4	3	9'-8"
H2	4	2	13'-8"
J	5	8	6'-0"
M1	5	8	5'-10"
M2	4	10	3'-8"

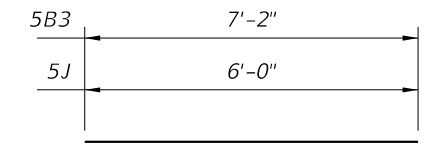

BARS 5B3 & 5J

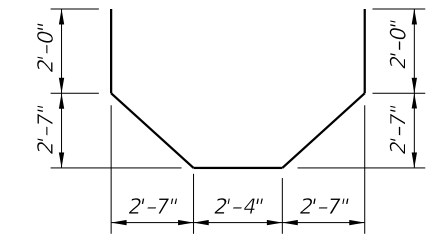

BAR 4H2

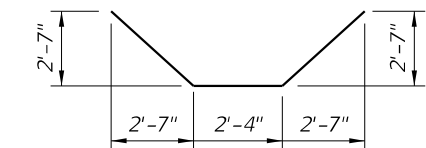

BAR 4H1

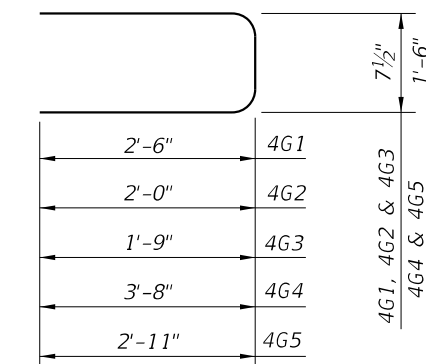

BARS 4G1, 4G2, 4G3, 4G4 & 4G5

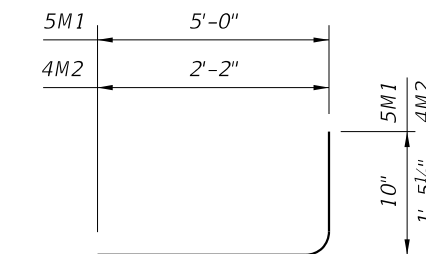

BAR 5M1 & 4M2

REINFORCING STEEL NOTES:

- All bar dimensions in the bending diagrams are out to out.
- Lap splices for Bars 4G1, 4G2, 4G3, 4G4 & 4G5 will be a minimum of 1'-4".
- The Contractor may use Welded Wire Reinforcement (WWR) when approved by the Engineer. WWR must consist of deformed wire meeting the requirements of Specification Section 931.

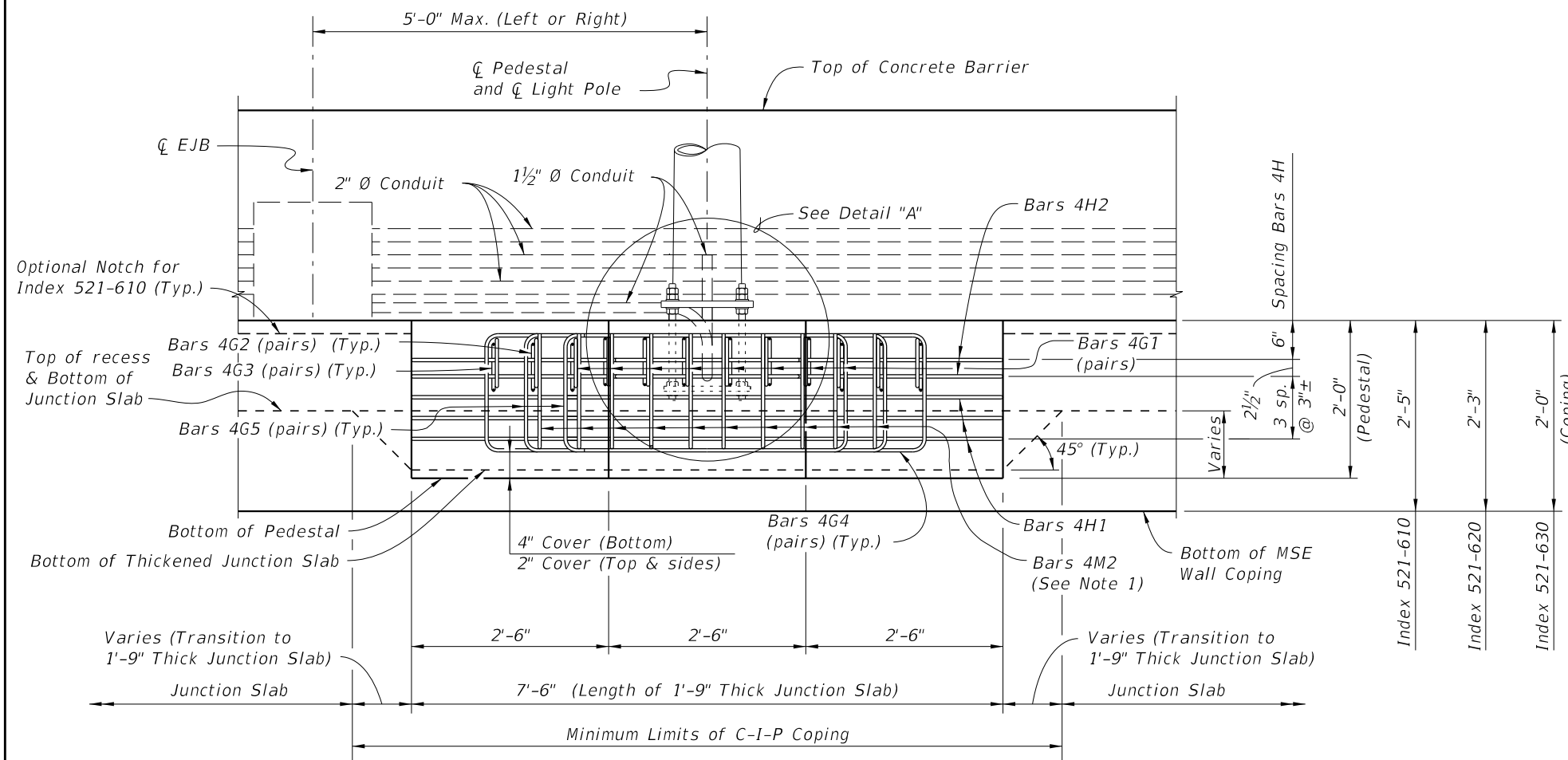

ELEVATION VIEW

(Junction Slab Reinforcing & Bars 4J not Shown for Clarity)
(Junction Slab Shown, Raised Sidewalk or Sidewalk Similar)

NOTES:

- Field Cut Bars 4M2 as required to maintain minimum cover.
- Maximum clearance between leveling nut and top of pedestal will not exceed anchor bolt diameter.

ESTIMATED QUANTITIES		
ITEM	UNIT	QUANTITY
Concrete (Pedestal)	CY	0.926
Concrete (Thickened Junction Slab)	CY	1.222
Reinforcing Steel	LB	334.09

(The quantities above are for one C-I-P Light Pole Pedestal. The concrete quantity for the thickened junction slab is based on a 5'-0" length, 9" increase in thickness and a 5" wide retaining wall panel. Adjust thickened concrete quantity as required.)

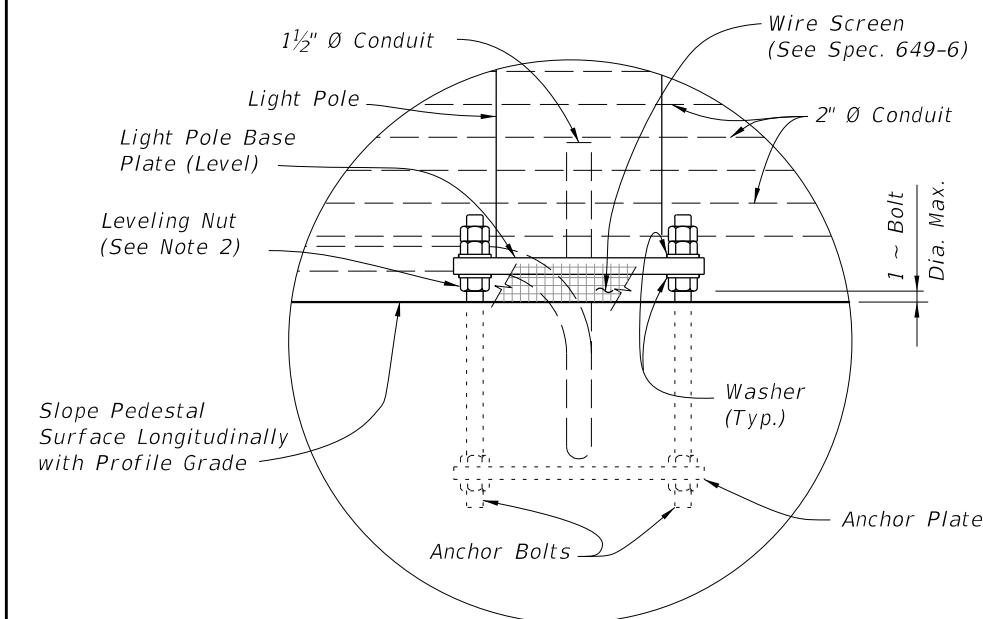

DETAIL "A"

10/20/2022 8:52:21 AM

GENERAL NOTES:

1. Construct sidewalks in accordance with Specification 522. Use 6" concrete for Sidewalks and Curb Ramps Located within Curb Returns (See Plan View). Install all other concrete with thickness as shown, unless otherwise detailed in the Plans.
2. Include detectable warnings on sidewalk curb ramps in accordance with Index 522-002.
3. For Driveways see Index 522-003.
4. Bond breaker material can be any impermeable coated or sheet membrane or preformed material having a thickness of not less than 6 mils and not more than 1/2".
5. Construct sidewalks with Edge Beam through the limits of any surface mounted Pedestrian/Bicycle Railing or Pipe Guiderail shown in the plans. (See RAILING DETAIL)

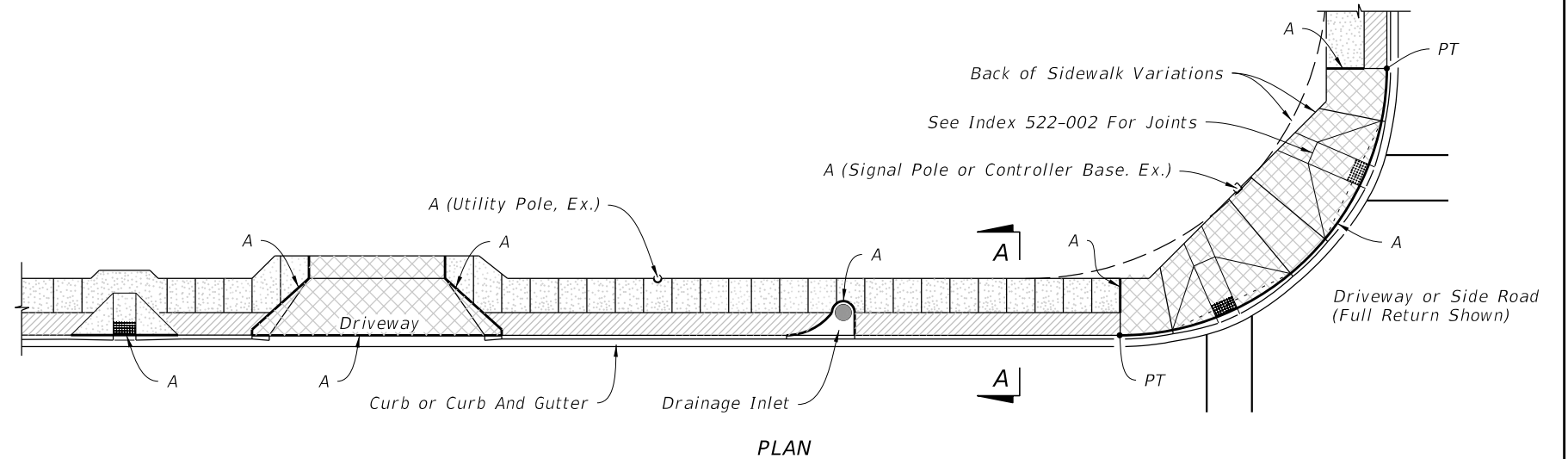

PLAN
SIDEWALK WITH UTILITY STRIP

LEGEND:

- 4" Thick Sidewalk
- 6" Thick Sidewalk
- Utility Strip

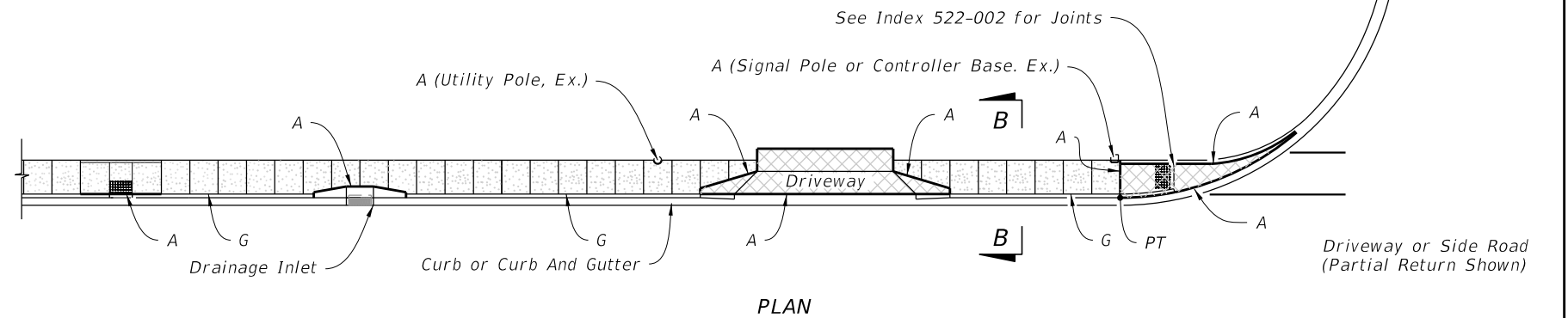

PLAN
SIDEWALK WITHOUT UTILITY STRIP

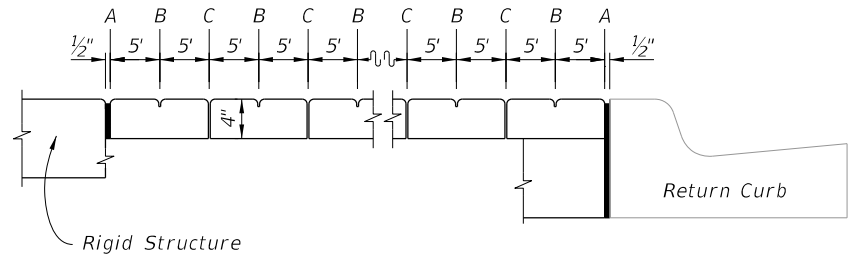

OPEN JOINTS

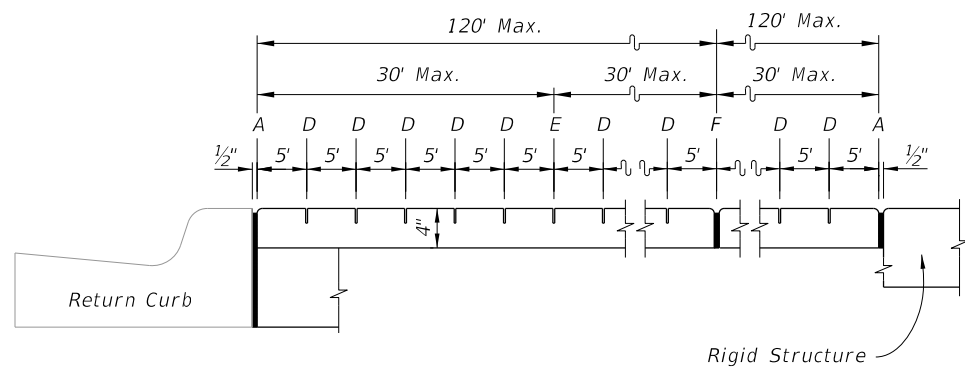

SAWED JOINTS

LONGITUDINAL SECTION

LEGEND:

- A- 1/2" Expansion Joints (Preformed Joint Filler) between the sidewalk and; driveways, sidewalk-intersections, and all other fixed objects (e.g. drainage inlets and utility poles).
- B- 1/8" Dummy Joints, Tooled
- C- 1/8" Formed Open Joints
- D- 3/16" Saw Cut Joints, 1 1/2" Deep (within 96 hours) Max. 5' Centers
- E- 3/16" Saw Cut Joints, 1 1/2" Deep (within 12 hours) Max. 30' Centers Joint(s) Required When Length Exceeds 30'
- F- 1/2" Expansion Joint When Run Of Sidewalk Exceeds 120'. Intermediate locations when called for in the plans or at locations as directed by the Engineer.
- G- Cold Joint With Bond Breaker, Tooled

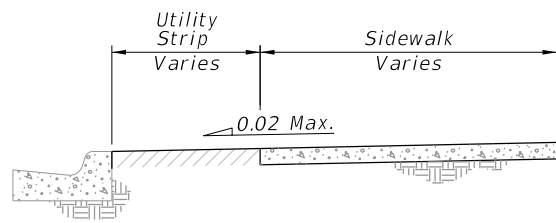

SECTION A-A

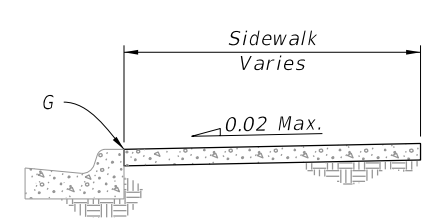

SECTION B-B

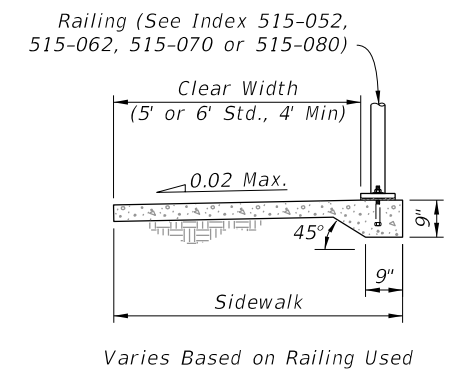

RAILING DETAIL

SIDEWALK JOINTS

GENERAL NOTES AND CONCRETE SIDEWALK ON CURBED ROADWAYS

10/20/2022 8:52:23 AM

LAST REVISION 11/01/18	DESCRIPTION:		FY 2023-24 STANDARD PLANS	CONCRETE SIDEWALK	INDEX 522-001	SHEET 1 of 2
---------------------------	--------------	--	------------------------------	-------------------	------------------	-----------------

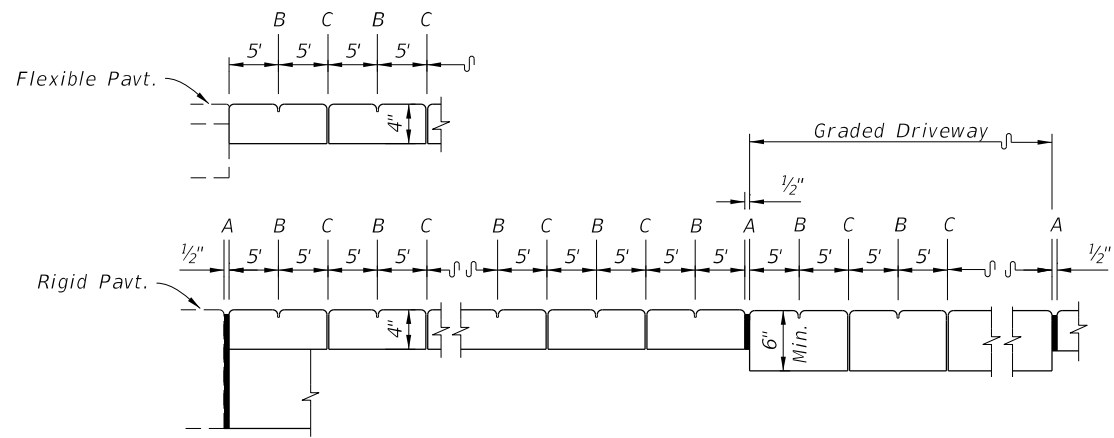

OPEN JOINTS

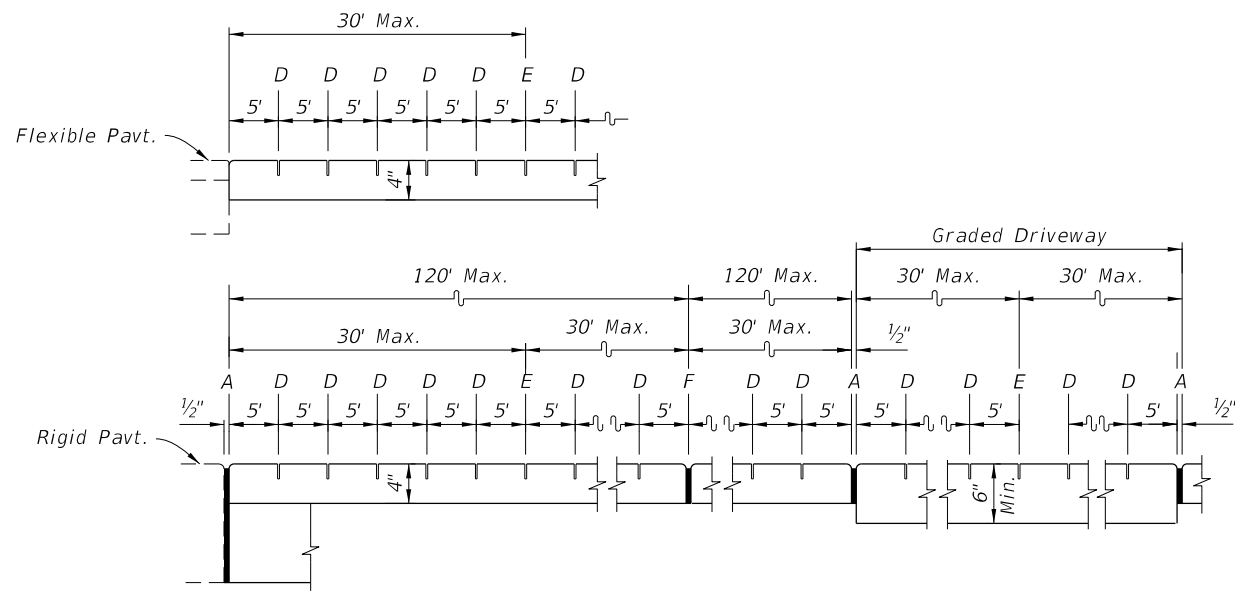

SAWED JOINTS

LONGITUDINAL SECTION

LEGEND:

- A- 1/2" Expansion Joints (Preformed Joint Filler) between the sidewalk and driveways, sidewalk-intersections, and all other fixed objects (e.g. drainage inlets and utility poles).
- B- 1/8" Dummy Joints, Tooled
- C- 1/8" Formed Open Joints
- D- 3/16" Saw Cut Joints, 1 1/2" Deep (within 96 hours) Max. 5' Centers
- E- 3/16" Saw Cut Joints, 1 1/2" Deep (within 12 hours) Max. 30' Centers Joint(s) Required When Length Exceeds 30'
- F- 1/2" Expansion Joint When Run Of Sidewalk Exceeds 120'. Intermediate locations when called for in the plans or at locations as directed by the Engineer.

SIDEWALK JOINTS

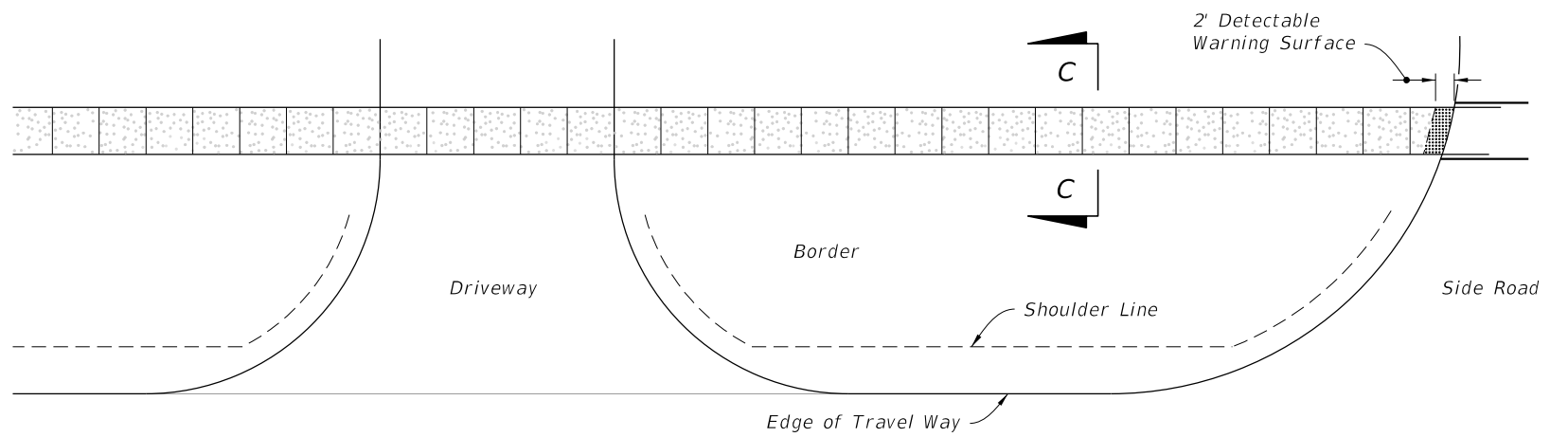

PLAN

CONTINUOUS SIDEWALK

LEGEND:

4" Thick Sidewalk

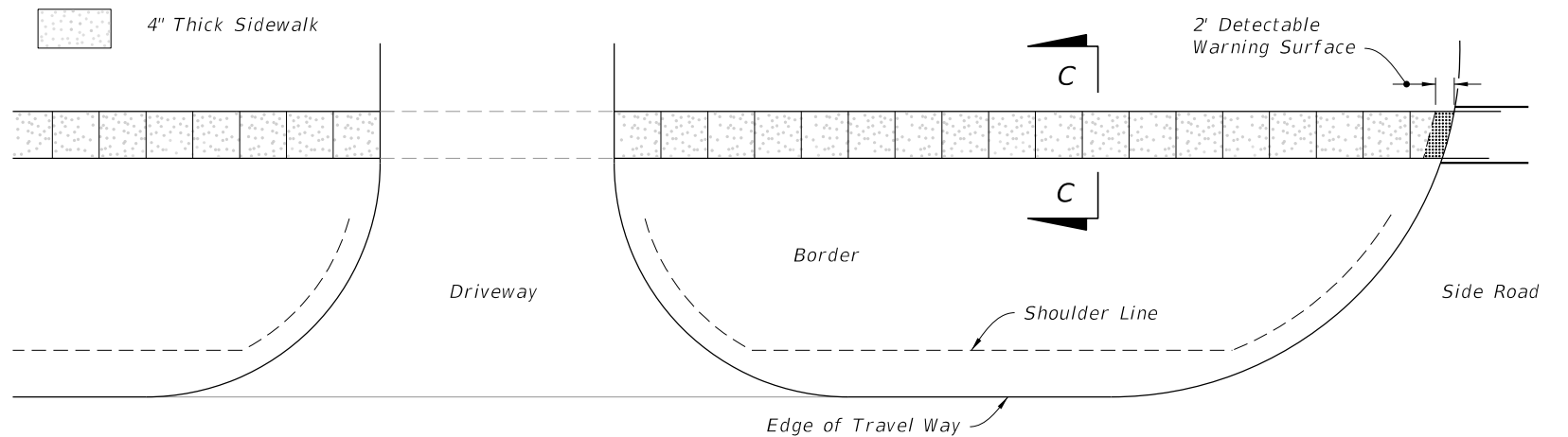

PLAN

DISCONTINUOUS SIDEWALK

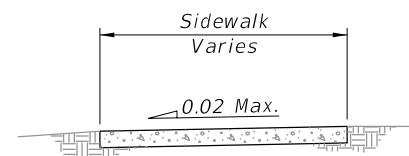

SECTION C-C

CONCRETE SIDEWALK ON FLUSH SHOULDER ROADWAYS

10/20/2022 8:52:24 AM

LAST REVISION 11/01/18	DESCRIPTION:
---------------------------	--------------



FY 2023-24
STANDARD PLANS

CONCRETE SIDEWALK

INDEX
522-001

SHEET
2 of 2

GENERAL NOTES:

1. Cross Slopes and Grades:

- A. Sidewalk, ramp, and landing slopes (i.e. 0.02, 0.05, and 1:12) shown in this Index are maximums. With approval of the Engineer, provide the minimum feasible slope where the requirements cannot be met.
- B. Landings must have cross-slopes less than or equal to 0.02 in any direction.
- C. Maintain a single longitudinal slope along each side of the curb ramp. Ramp slopes are not required to exceed 15 feet in length.
- D. Joints permitted at the location of Slope Breaks. Otherwise locate joints in accordance with Index 522-001. No joints are permitted within the ramp portion of the Curb Ramp.

2. Curb, Curb and Gutter and/or Sidewalk:

- A. Refer to Index 522-001 for concrete thickness and sidewalk details.
- B. Remove any existing curb, curb and gutter, or sidewalk to the nearest joint beyond the curb transition or to the extent that no remaining section is less than 5 feet long.
- C. Width of Curb Ramp is 4'-0" minimum. Match sidewalk or Shared Use Path width as shown in the Plans.

3. Curb Ramp Alpha-Identification:

- A. Sidewalk curb ramp alpha-identifications (e.g. CR-A) are provided for reference purposes in the Plans.
- B. Alpha-identifications CR-I and CR-J are intentionally omitted.

4. Detectable Warnings:

- A. Install detectable warnings in accordance with Specification 527.
- B. Place detectable warnings across the full width of the ramp or landing, to a minimum depth of 2 feet measured perpendicular to the curb line and no greater than 5 feet from the back of the curb or edge of pavement.
- C. If detectable warnings are shown in the Plans on slopes greater than 5%, align the truncated domes with the centerline of the ramp; otherwise, the truncated domes are not required to be aligned.

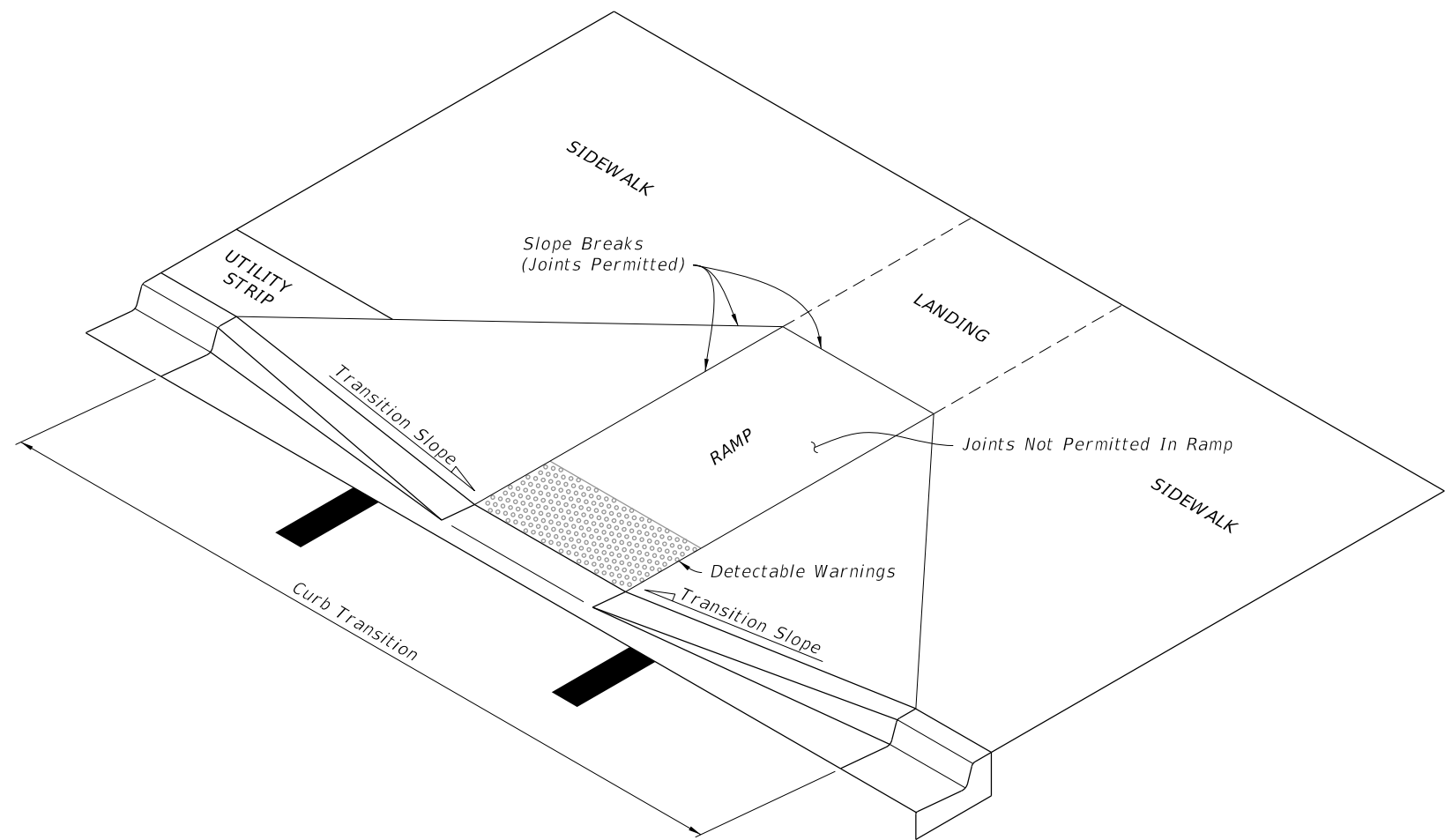

==== CURB RAMP NOMENCLATURE =====

10/20/2022 8:52:25 AM

LAST REVISION 11/01/21	REVISION	DESCRIPTION:	 FY 2023-24 STANDARD PLANS	DETECTABLE WARNINGS AND SIDEWALK CURB RAMPS	INDEX 522-002	SHEET 1 of 7
------------------------------	----------	--------------	---	---	------------------	-----------------

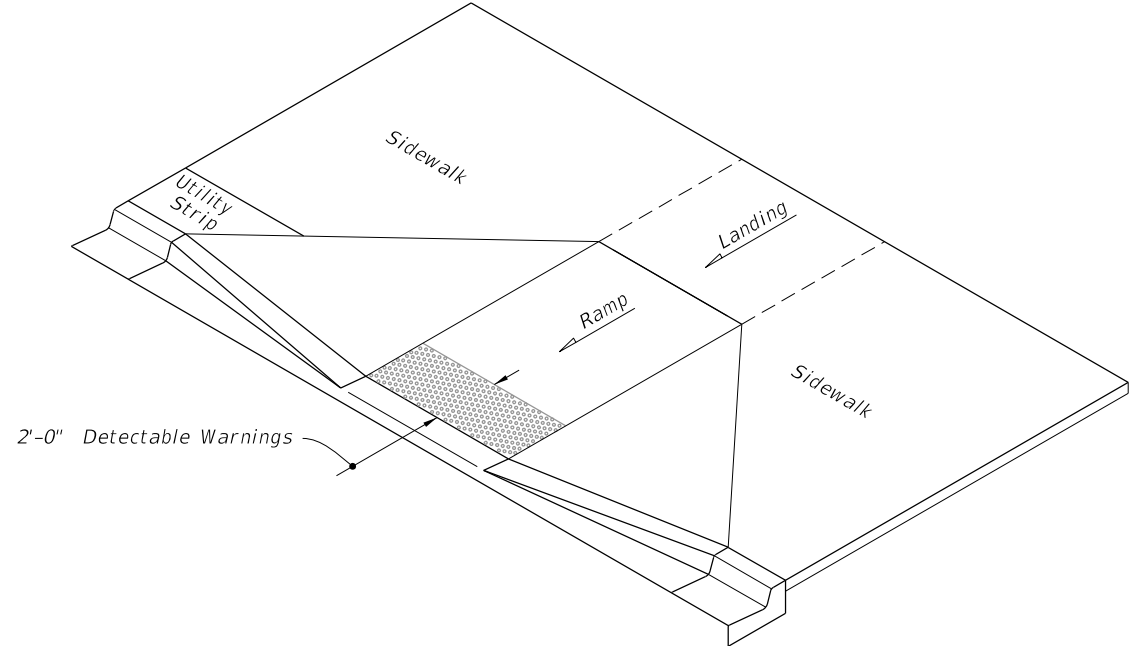

ISOMETRIC VIEW

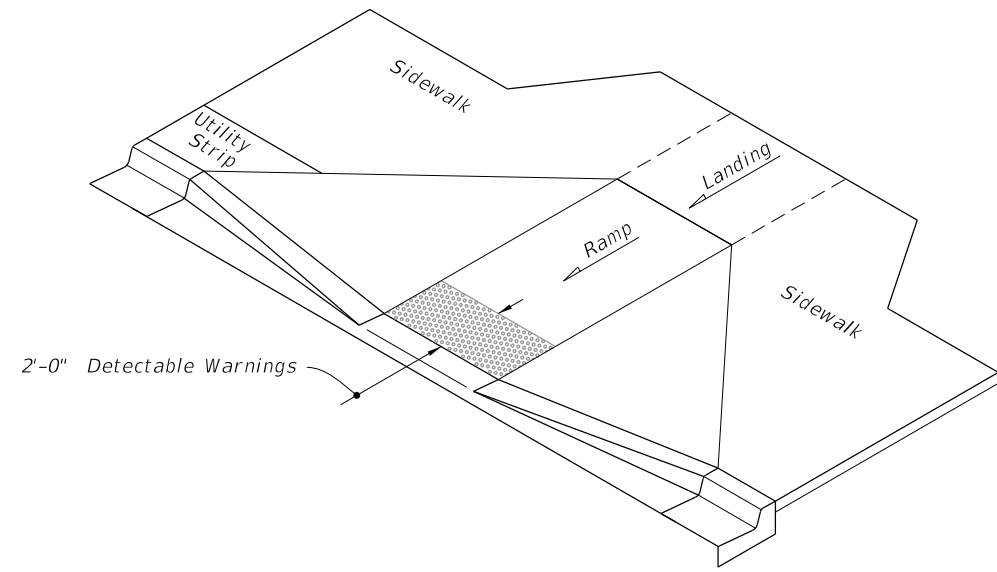

ISOMETRIC VIEW

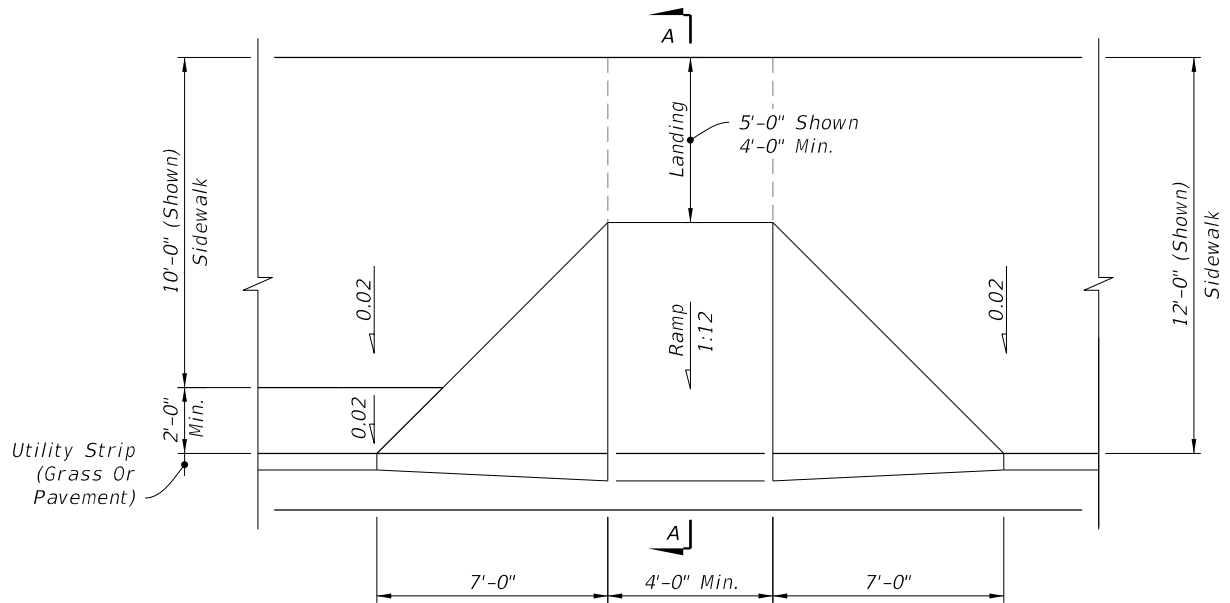

PLAN VIEW

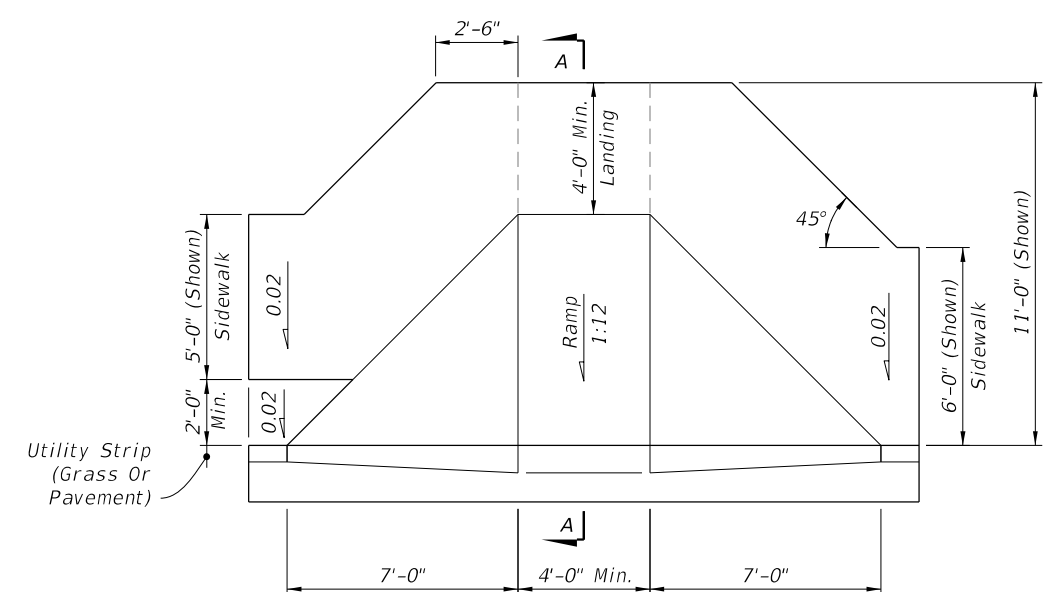

PLAN VIEW

NOTE: For Example of CR-A used in Radial Curb Returns, See Sheet 7.

CR-A

CR-B

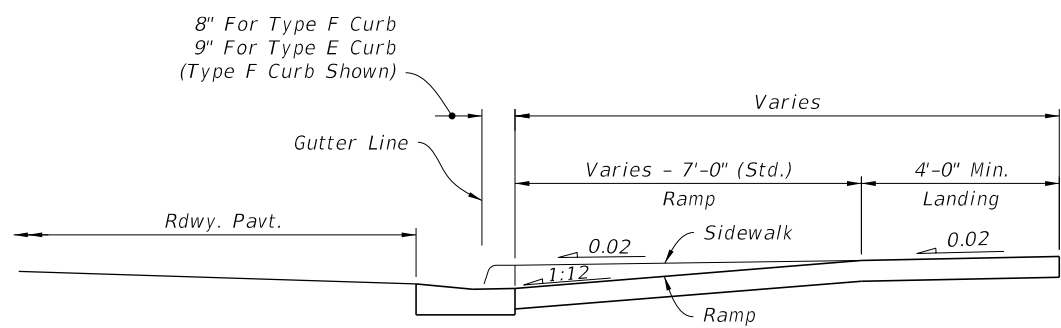

SECTION A-A

SIDEWALK CURB RAMPS CR-A AND CR-B

5/24/2024 9:21:10 AM

LAST REVISION 11/01/20	REVISION	DESCRIPTION:		FY 2023-24 STANDARD PLANS	DETECTABLE WARNINGS AND SIDEWALK CURB RAMPS	INDEX 522-002	SHEET 2 of 7
---------------------------	----------	--------------	--	------------------------------	---	------------------	-----------------

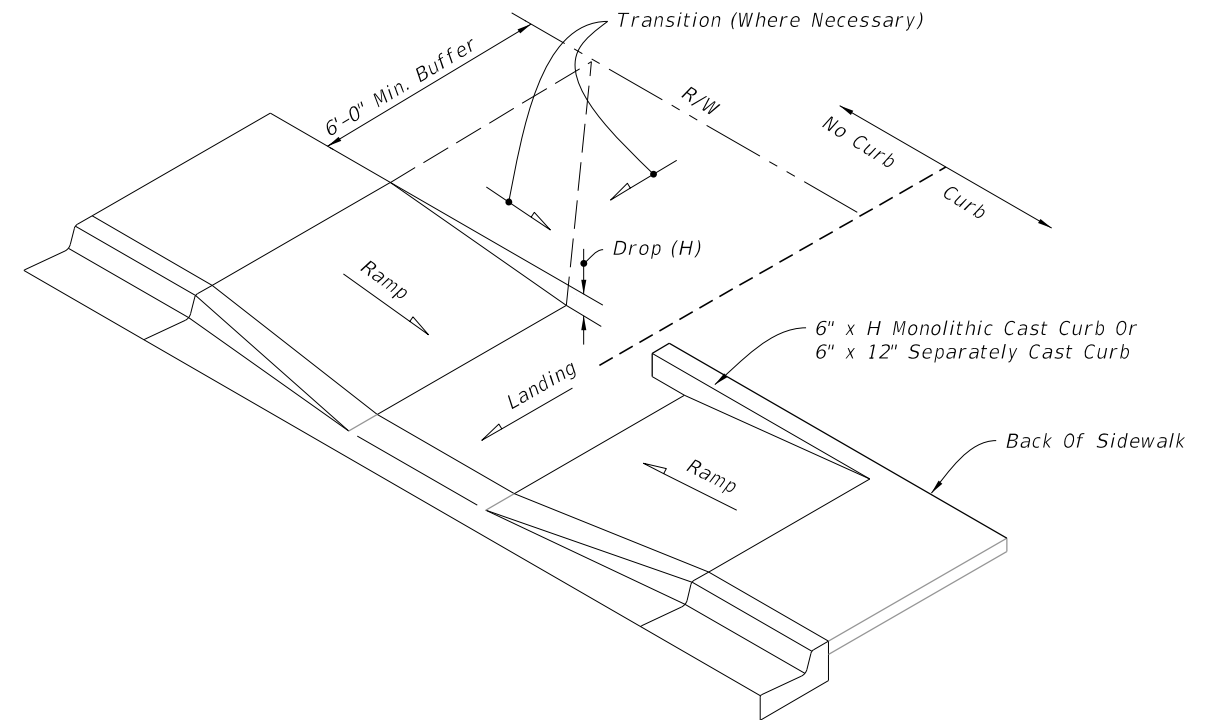
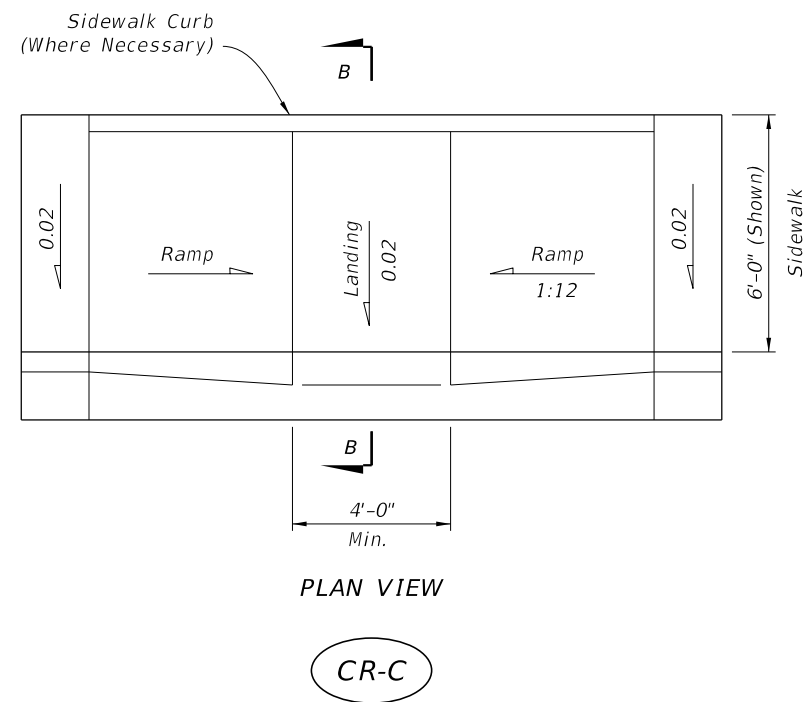

CONSTRUCTION OF SIDEWALK CURB IN CUT SECTIONS

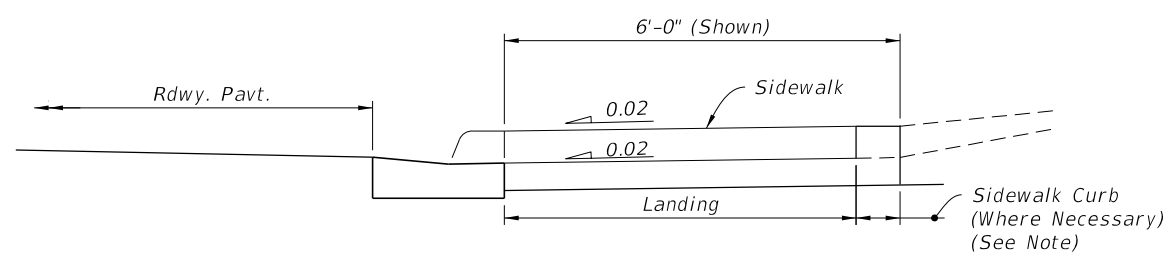

NOTE: For additional information on sidewalk curb construction, see SIDEWALK CURB OPTIONS details.

SECTION B-B

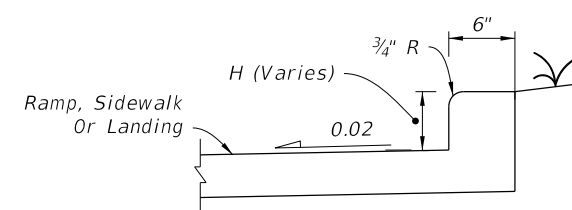

MONOLITHIC CAST CURB

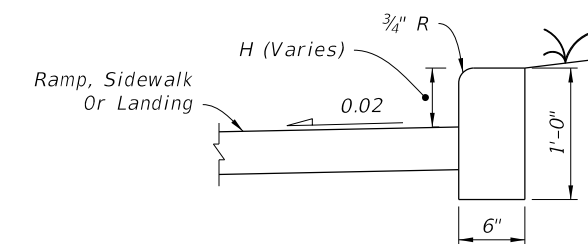

SEPARATELY CAST CURB

SIDEWALK CURB OPTIONS

SIDEWALK CURB RAMPS CR-C AND SIDEWALK CURB

10/20/2022 8:52:27 AM

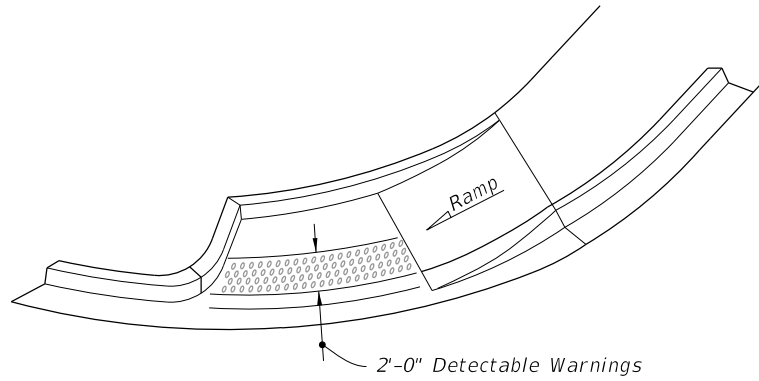

ISOMETRIC VIEW

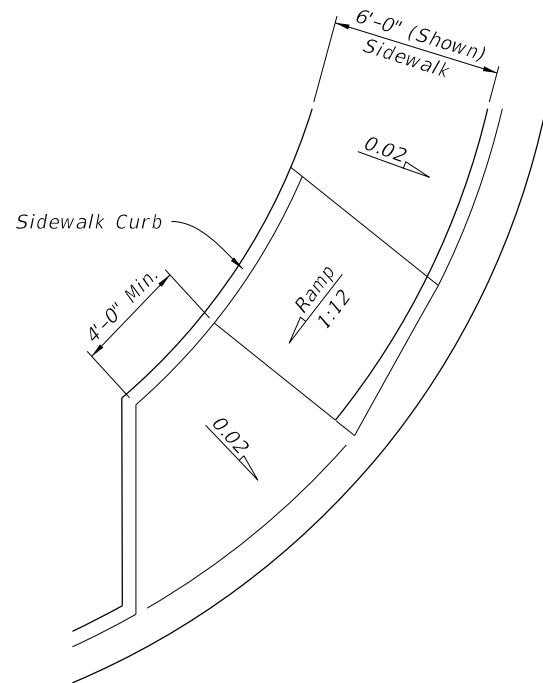

PLAN VIEW

CR-D

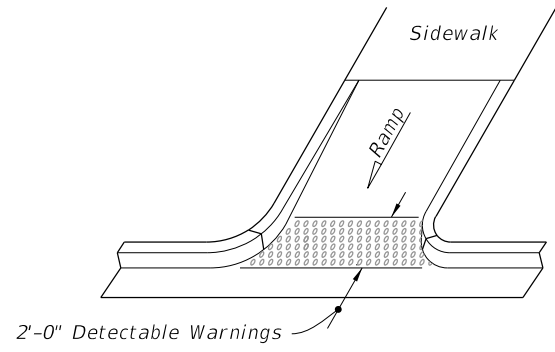

OPTION A

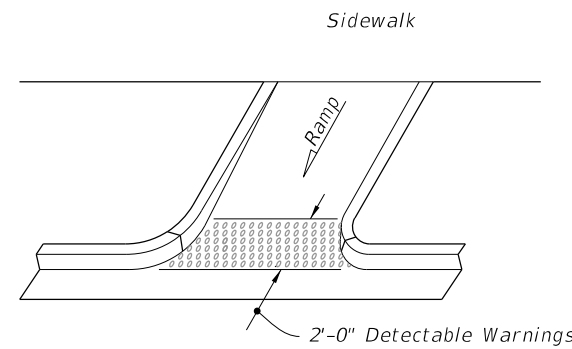

OPTION B ISOMETRIC VIEW

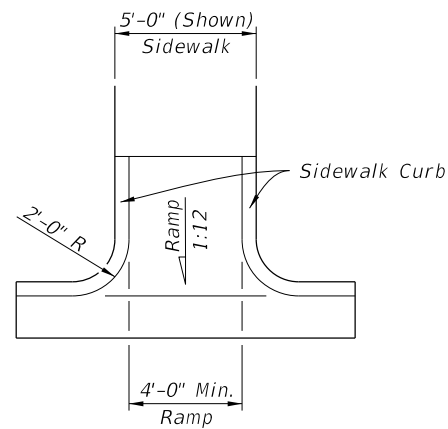

PLAN VIEW

CR-E

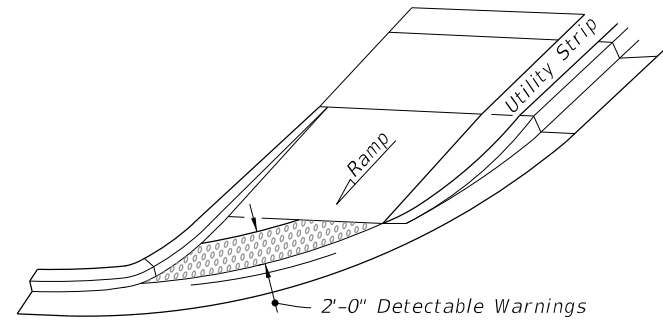

OPTION A

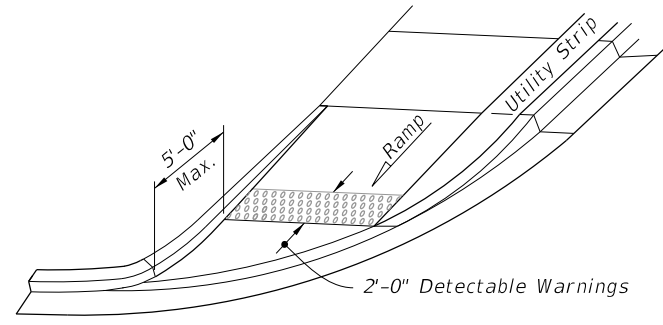

OPTION B

ISOMETRIC VIEW

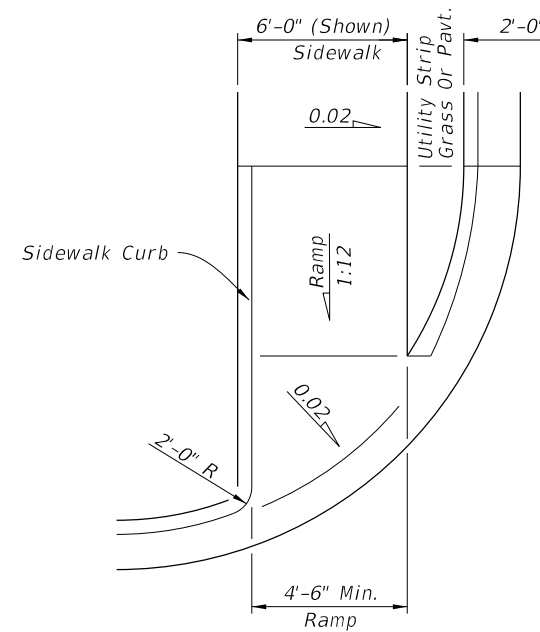

PLAN VIEW

CR-F

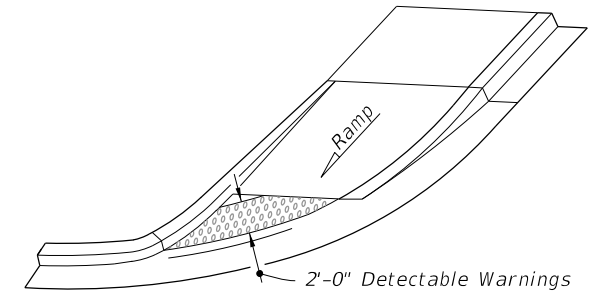

OPTION A

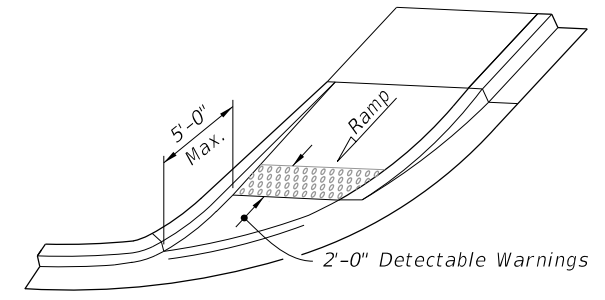

OPTION B

ISOMETRIC VIEW

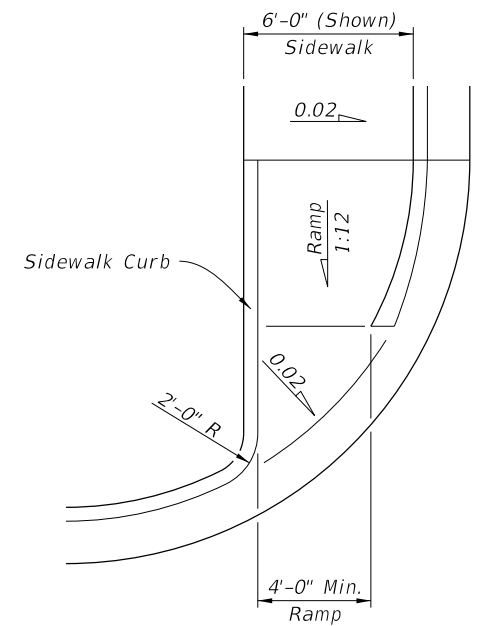

PLAN VIEW

CR-G

SIDEWALK CURB RAMPS CR-D, CR-E, CR-F & CR-G

LAST REVISION 11/01/21	DESCRIPTION:
---------------------------	--------------



FY 2023-24
STANDARD PLANS

DETECTABLE WARNINGS AND SIDEWALK CURB RAMPS

INDEX
522-002

SHEET
4 of 7

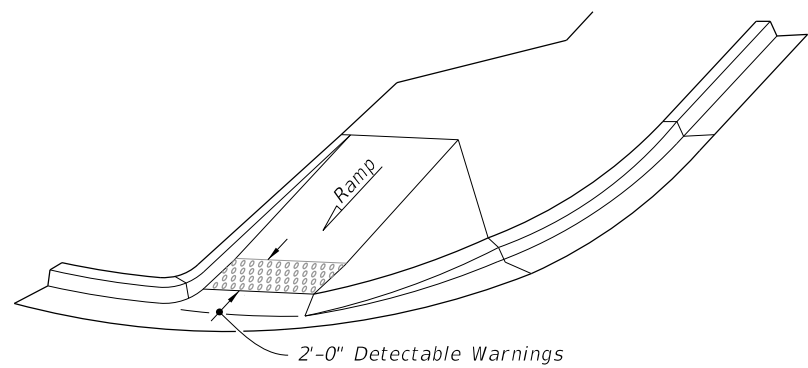

ISOMETRIC VIEW

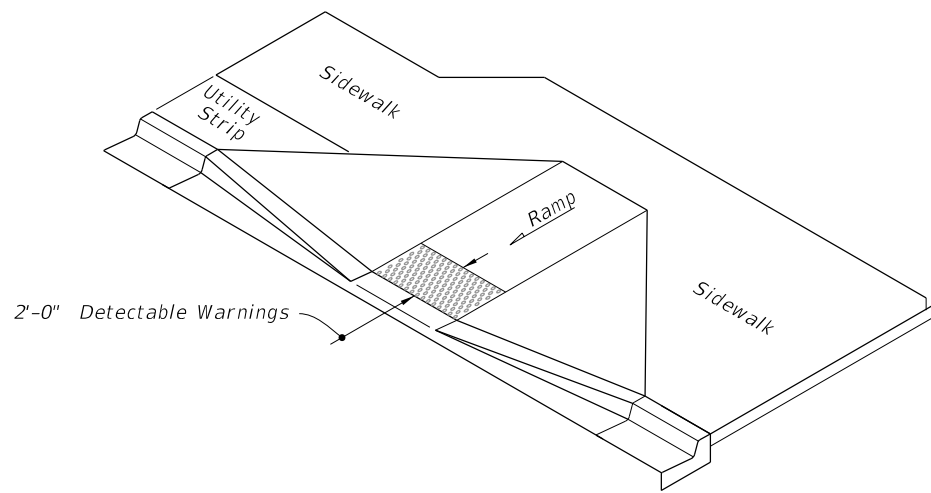

ISOMETRIC VIEW

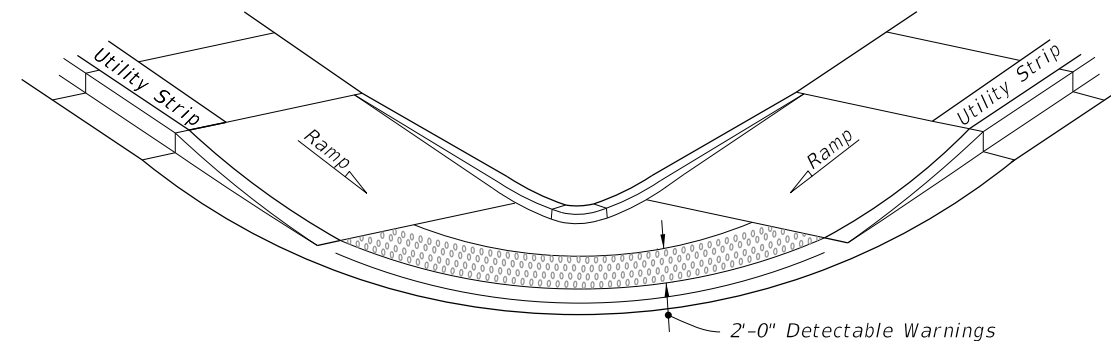

OPTION A

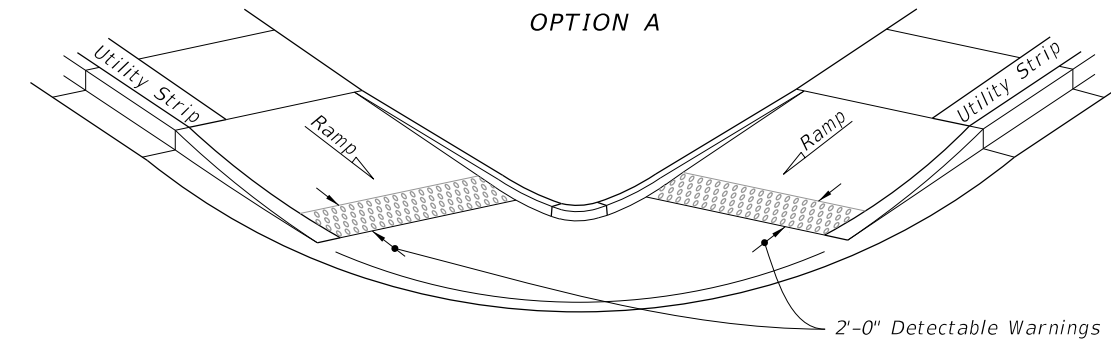

OPTION B

ISOMETRIC VIEW

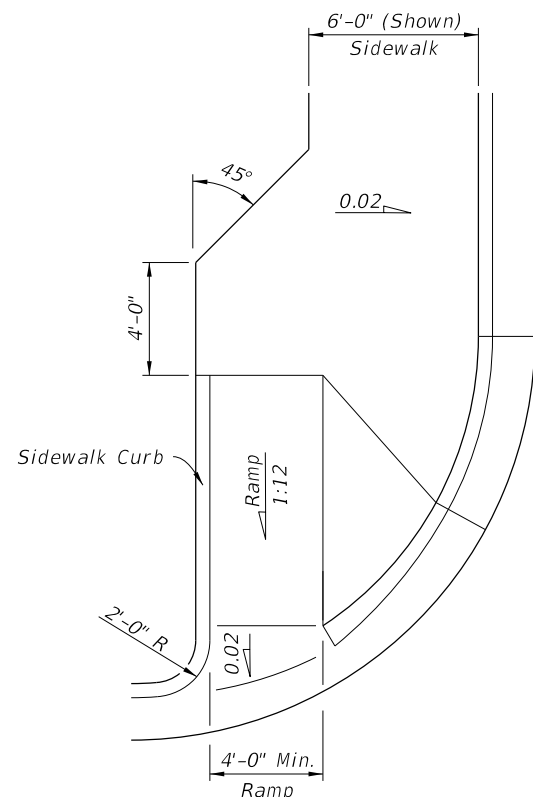

PLAN VIEW

CR-H

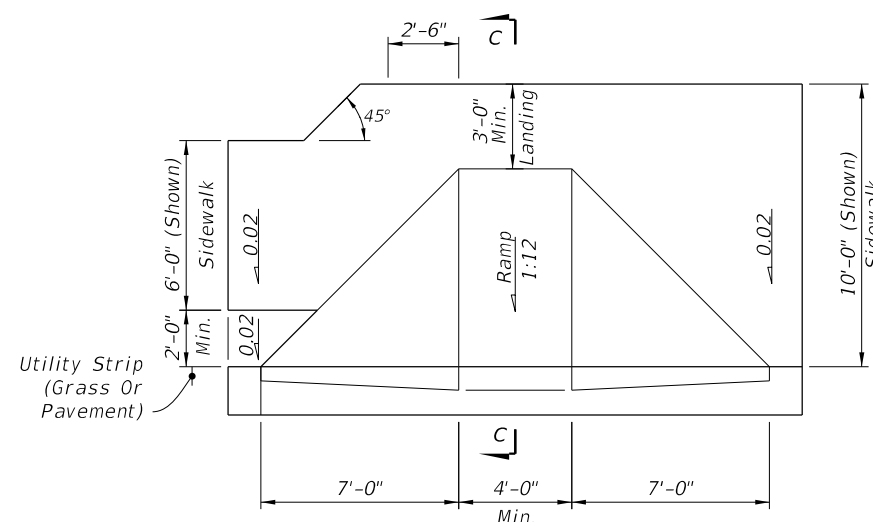

PLAN VIEW

CR-K

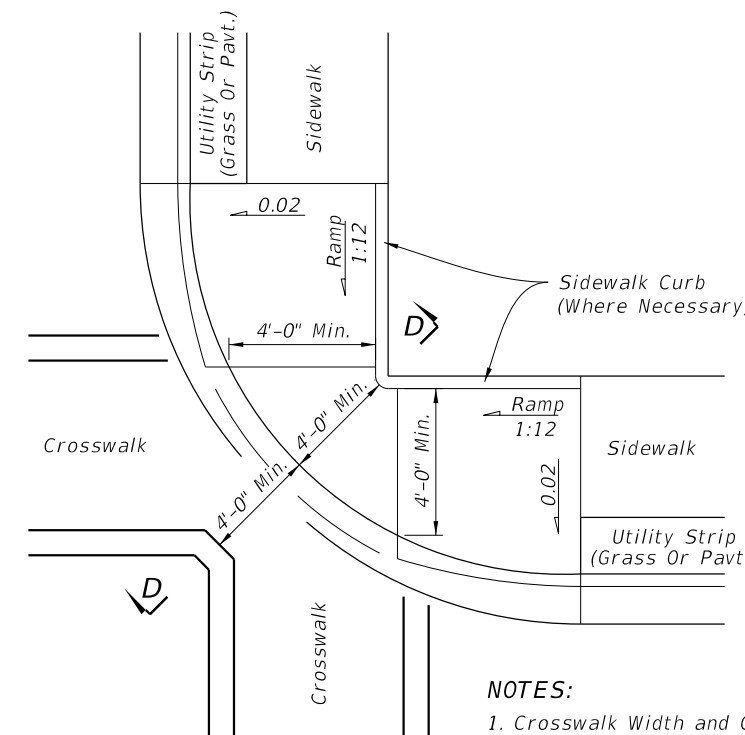

PLAN VIEW

CR-L

- NOTES:
1. Crosswalk Width and Configuration Vary; Must Conform to Index 711-001.
 2. 15' Radius Curve Shown for CR-L.
 3. For additional information on sidewalk curb construction, see SIDEWALK CURB OPTIONS details, on Sheet 3.

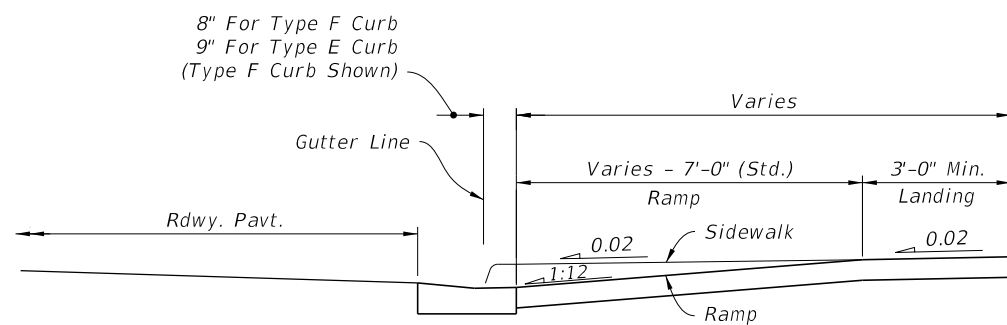

SECTION C-C

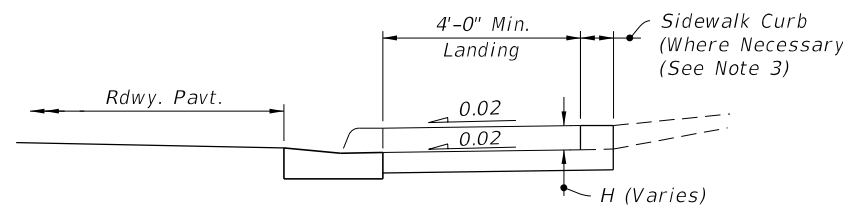

SECTION D-D

SIDEWALK CURB RAMPS CR-H, CR-K & CR-L

10/20/2022 8:52:27 AM

LAST REVISION	DESCRIPTION:
11/01/20	



FY 2023-24
STANDARD PLANS

DETECTABLE WARNINGS AND SIDEWALK CURB RAMPS

INDEX
522-002

SHEET
5 of 7

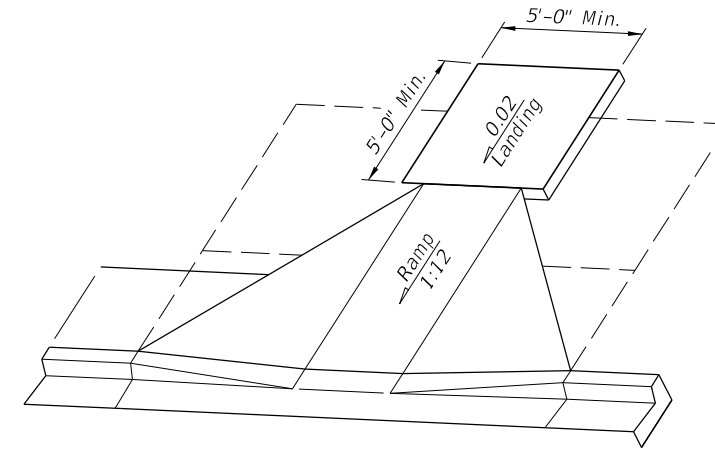
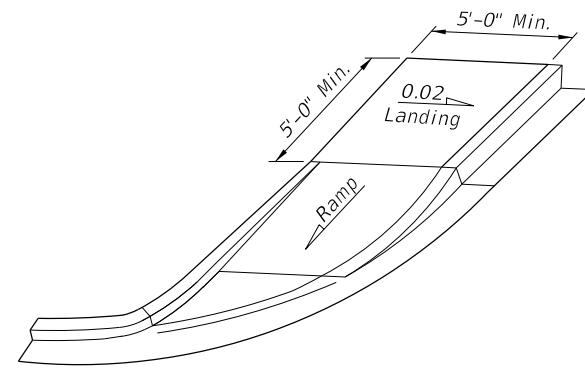
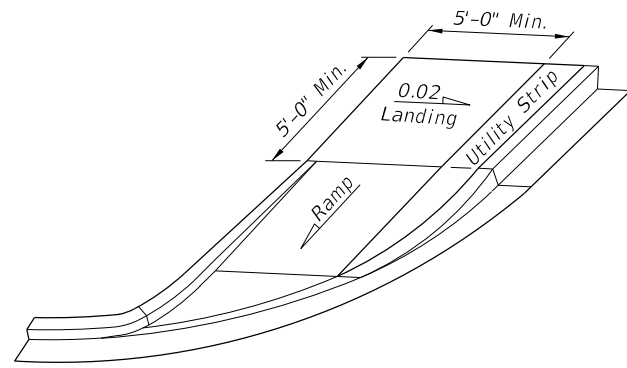

LANDINGS FOR CURB RAMPS WITHOUT SIDEWALKS

(See CR-F, CR-G & CR-K Respectively For Detectable Warning Details/Options)

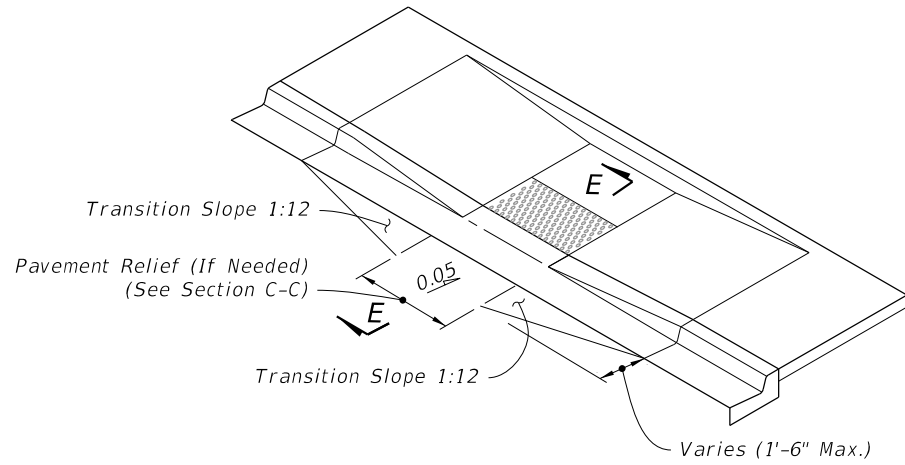

ISOMETRIC VIEW
(CR-C Shown, Other Similar)

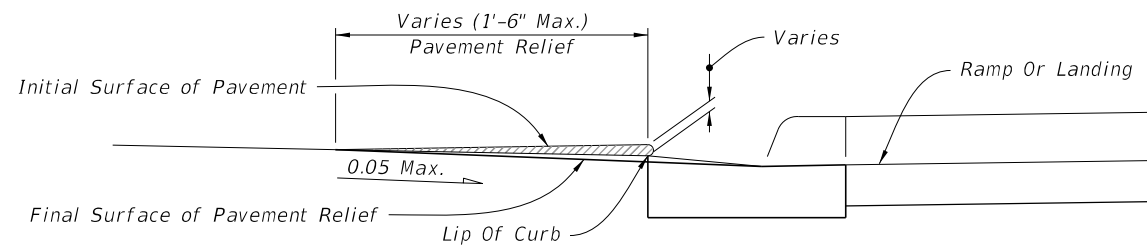

NOTE: Remove Elevated Pavement By Spading And Rolling, Smooth Milling, or Grinding.

SECTION E-E

PAVEMENT RELIEF DETAILS

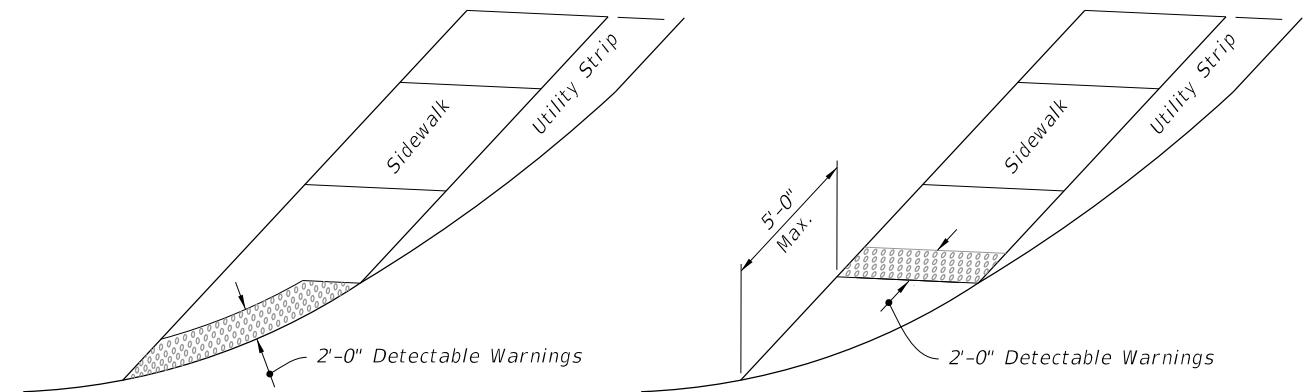

OPTION A

OPTION B

DETECTABLE WARNING ON FLUSH SHOULDER SIDEWALKS

CURB RAMPS WITHOUT SIDEWALKS AND FLUSH SHOULDER SIDEWALKS

10/20/2022 8:52:28 AM

LAST REVISION 11/01/20	REVISION	DESCRIPTION:
---------------------------	----------	--------------



FY 2023-24
STANDARD PLANS

DETECTABLE WARNINGS AND SIDEWALK CURB RAMPS

INDEX
522-002

SHEET
6 of 7

NOTES:

1. Where crosswalk markings are used, ramps must fall within the crosswalk limits. A clear space of 48" minimum is required at the bottom of the ramp within a marked crosswalk. If crosswalk markings are not present, a clear space of 48" minimum is required at the bottom of the ramp outside of active travel lanes.
2. Crosswalk widths and configurations vary; must conform to Index 711-001.
3. Flangeway Gap may be up to 3" for Freight-only Railways.

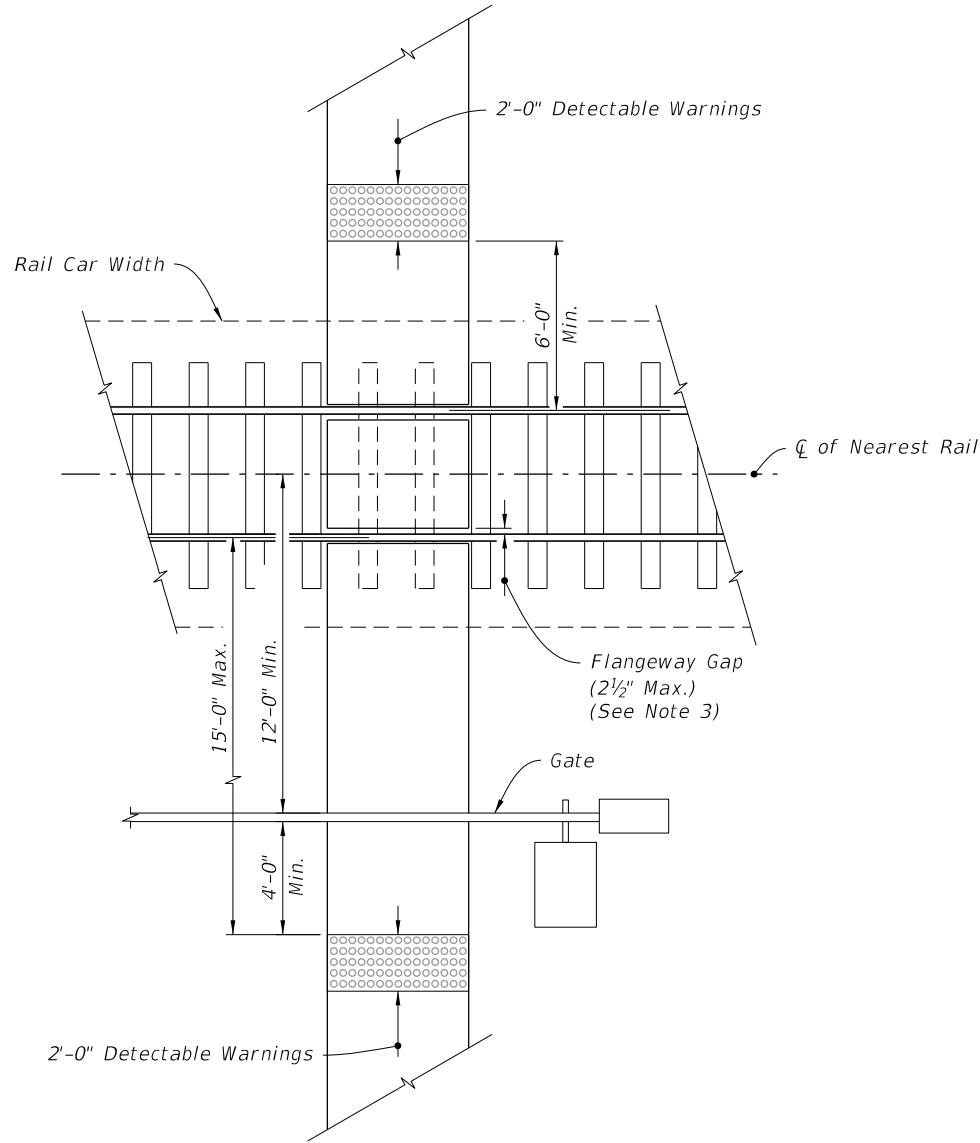

RAILROAD CROSSING

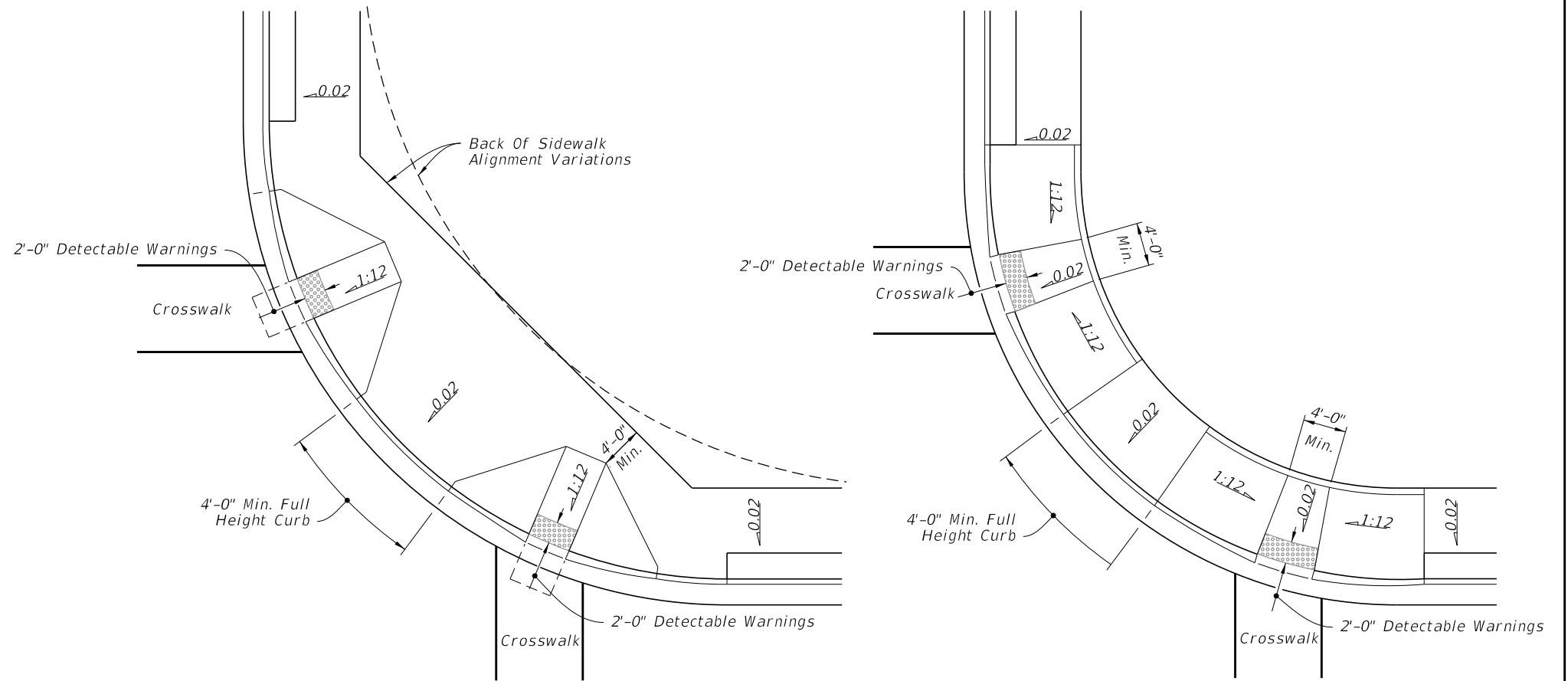

CURB RAMPS WITHIN RADIAL RETURN

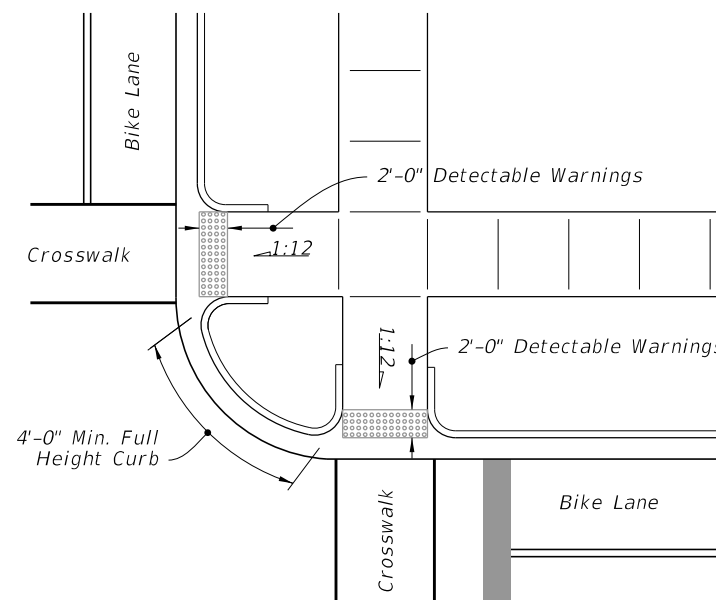

CURB RAMPS OUTSIDE RADIAL RETURN

PLACEMENT OF SIDEWALK CURB RAMPS AT CURBED RETURNS (TYP.)

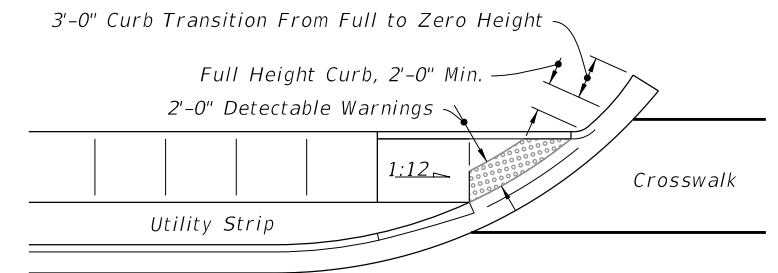

LINEAR SIDEWALK RAMPS

RAILROAD CROSSING AND CURB RAMPS AT CURBED RETURNS





12/13/2022 8:33:09 AM

LAST REVISION 11/01/20	REVISION	DESCRIPTION:		FY 2023-24 STANDARD PLANS	DETECTABLE WARNINGS AND SIDEWALK CURB RAMPS	INDEX 522-002	SHEET 7 of 7
---------------------------	----------	--------------	--	------------------------------	---	------------------	-----------------

GENERAL NOTES:

1. Work this Index with Specification 522.
2. Refer to Index 520-001 for drop curb details and Index 522-001 for joints between driveway, sidewalks, and curb.
3. Existing Curb and Gutter:
Remove existing curb and gutter to either the nearest joint beyond the flared point or to where no remaining section is less than 5 feet long.
4. Grades and cross slopes shown are maximums.
5. Longitudinal Joints:
Construct $\frac{1}{8}$ " open joints placed at equal (20' max.) intervals for driveways over 20' wide. Match joints in curb and gutter to match joints in driveways.
6. Transverse Joints:
Construct $\frac{1}{8}$ " open joints @ 10' Centers and $\frac{1}{2}$ " expansion joints with preformed joint filler every 5th joint.
7. Construct driveways (6" thick concrete) to a uniform width (W) to the R/W line or the extent shown in the Plans.
8. Width of Sidewalk Thru Driveway is 4'-0" minimum. Match sidewalk width when shown in Plans or when utility strip width is equal to or greater than the depth of the Driveway Apron.
9. Alpha-Numeric Identification:
Concrete Flared Driveway Alpha-Numeric Identifications (e.g. G4) are provided for reference purposes in the Plans.

LEGEND:

-  Sidewalk
-  Flared Driveway (6" Thick Concrete)
-  Sidewalk Thru Driveway (6" Thick Concrete)
-  Utility Strip
- G_A Grade of Apron
- G_D Grade of Driveway (Per Plans)

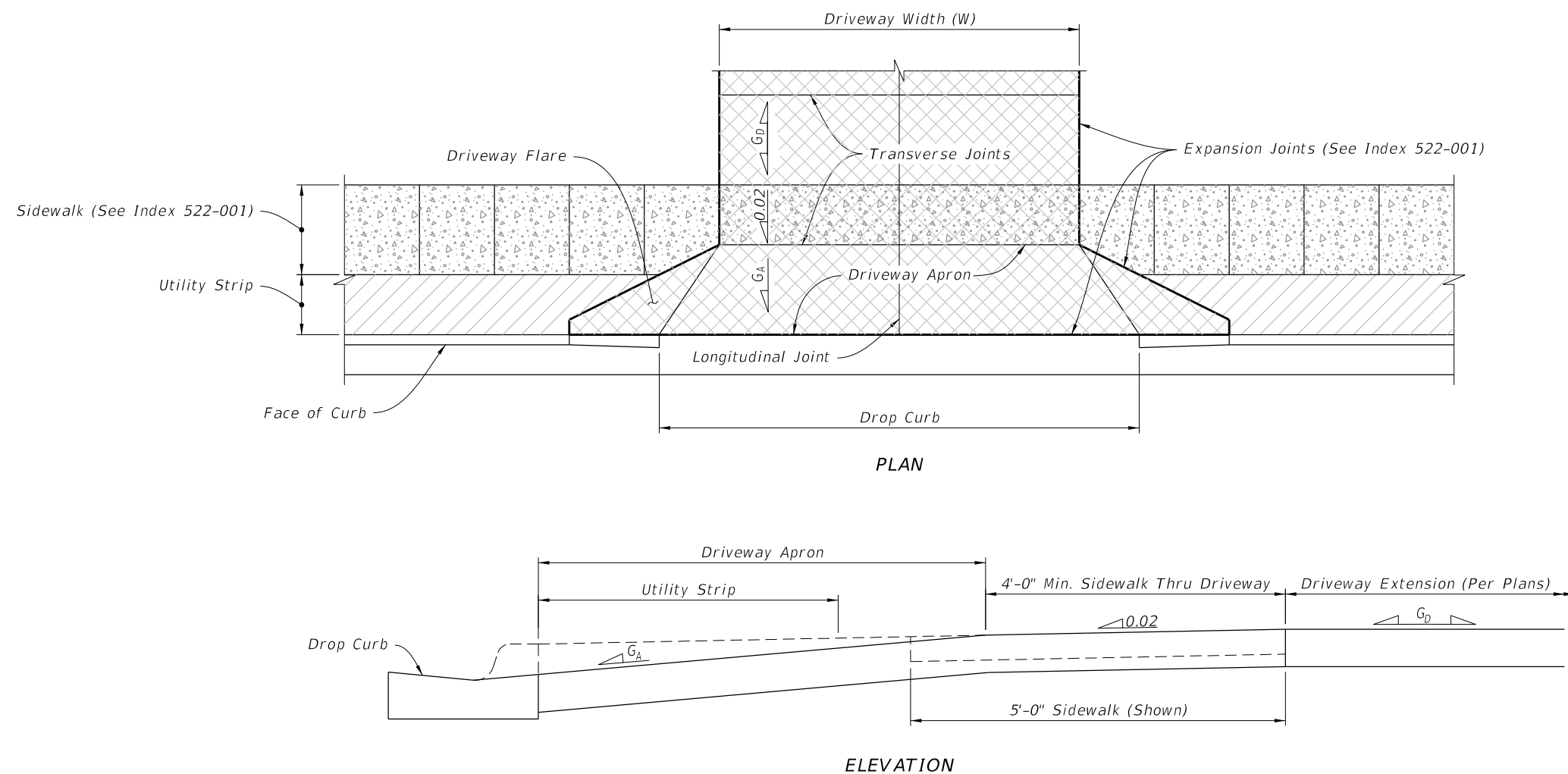

CONCRETE FLARED DRIVEWAY NOMENCLATURE

10/20/2022 8:52:30 AM

LAST REVISION 11/01/18	REVISION	DESCRIPTION:		FY 2023-24 STANDARD PLANS	CONCRETE FLARED DRIVEWAYS	INDEX 522-003	SHEET 1 of 4
---------------------------	----------	--------------	---	------------------------------	---------------------------	------------------	-----------------

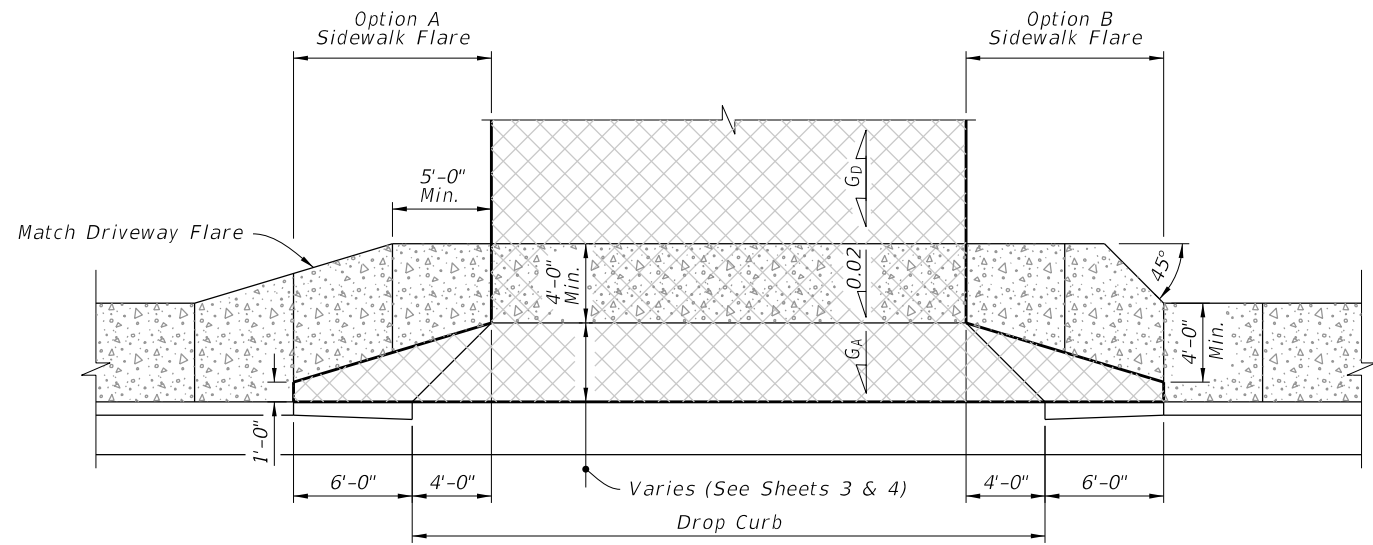

SIDEWALK WITHOUT UTILITY STRIP

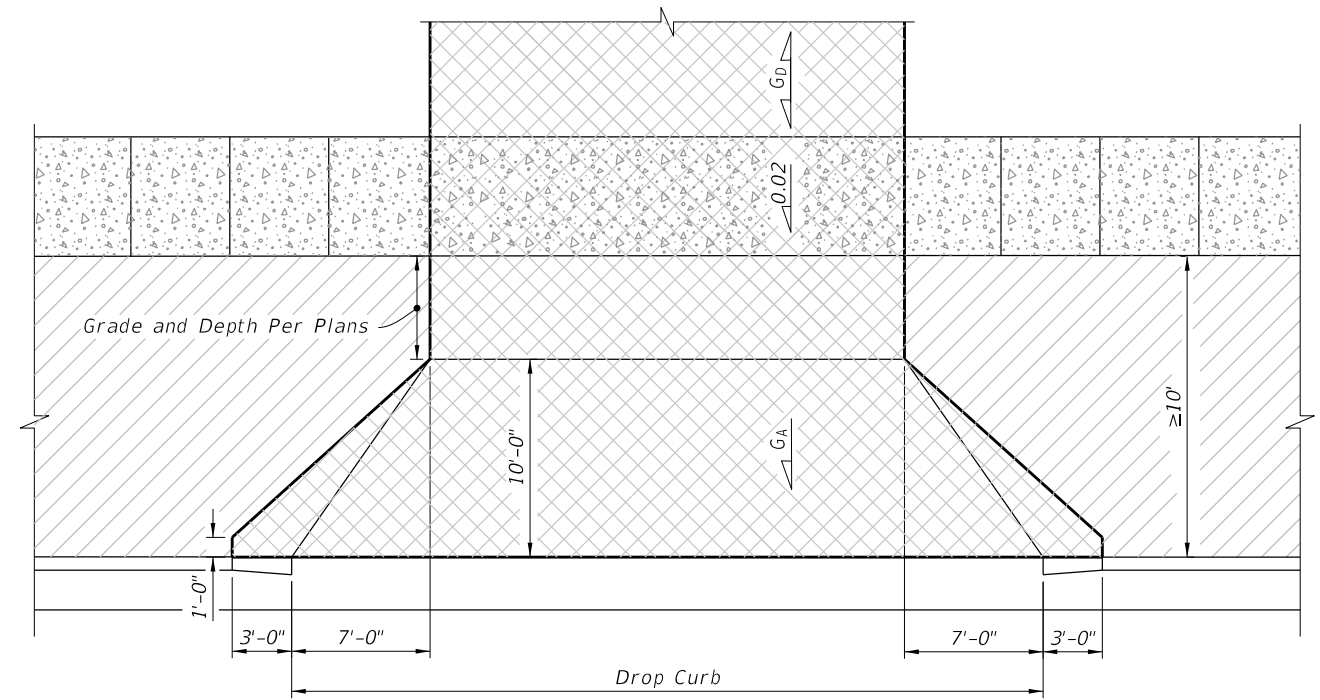

WITHOUT SIDEWALK OR UTILITY STRIP $\geq 10'$ WIDE

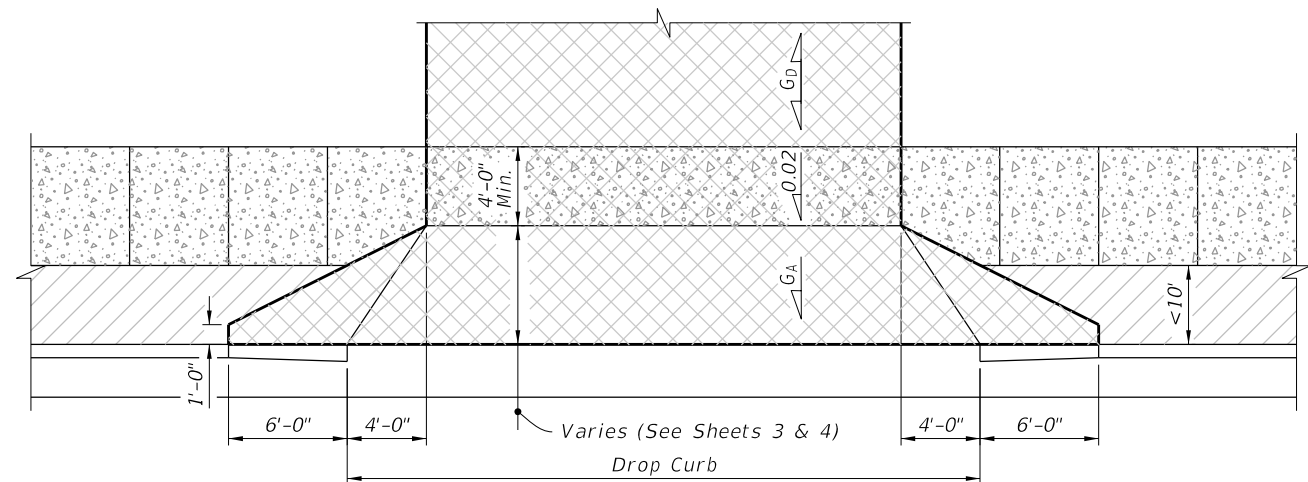

UTILITY STRIP $< 10'$ WIDE

LEGEND:

-  Sidewalk
-  Flared Driveway (6" Thick Concrete)
-  Sidewalk Thru Driveway (6" Thick Concrete)
-  Utility Strip

10/20/2022 8:52:31 AM

LAST REVISION 11/01/18	REVISION	DESCRIPTION:		FY 2023-24 STANDARD PLANS	CONCRETE FLARED DRIVEWAYS	INDEX 522-003	SHEET 2 of 4
---------------------------	----------	--------------	--	------------------------------	---------------------------	------------------	-----------------

10/20/2022 8:52:32 AM

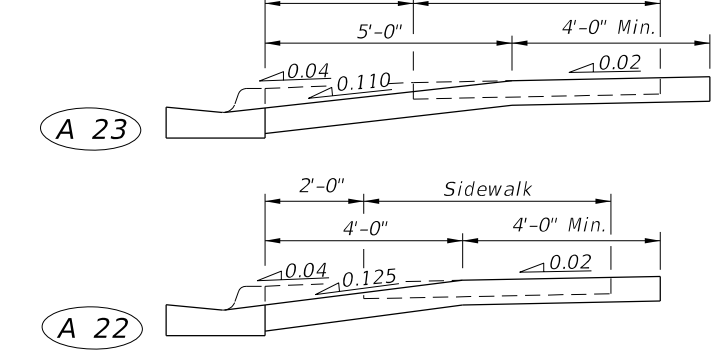
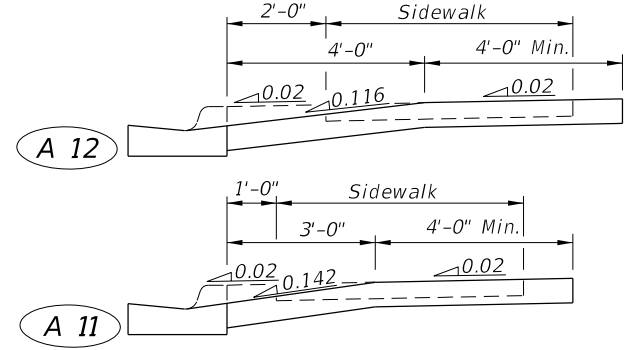
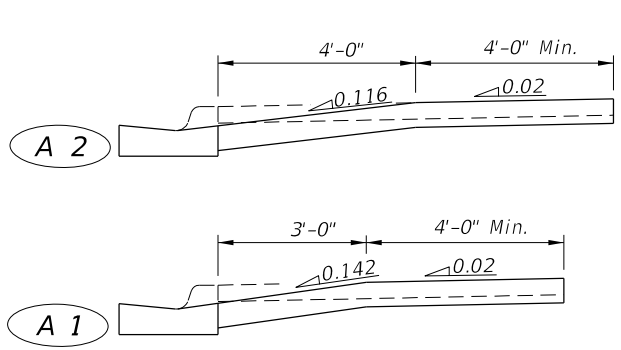
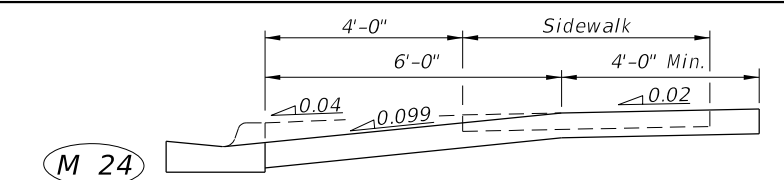
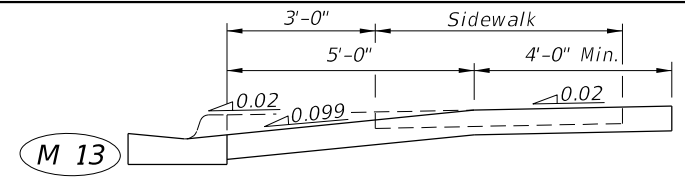
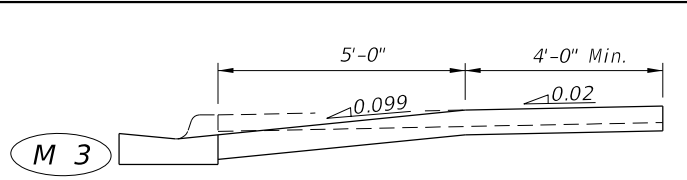
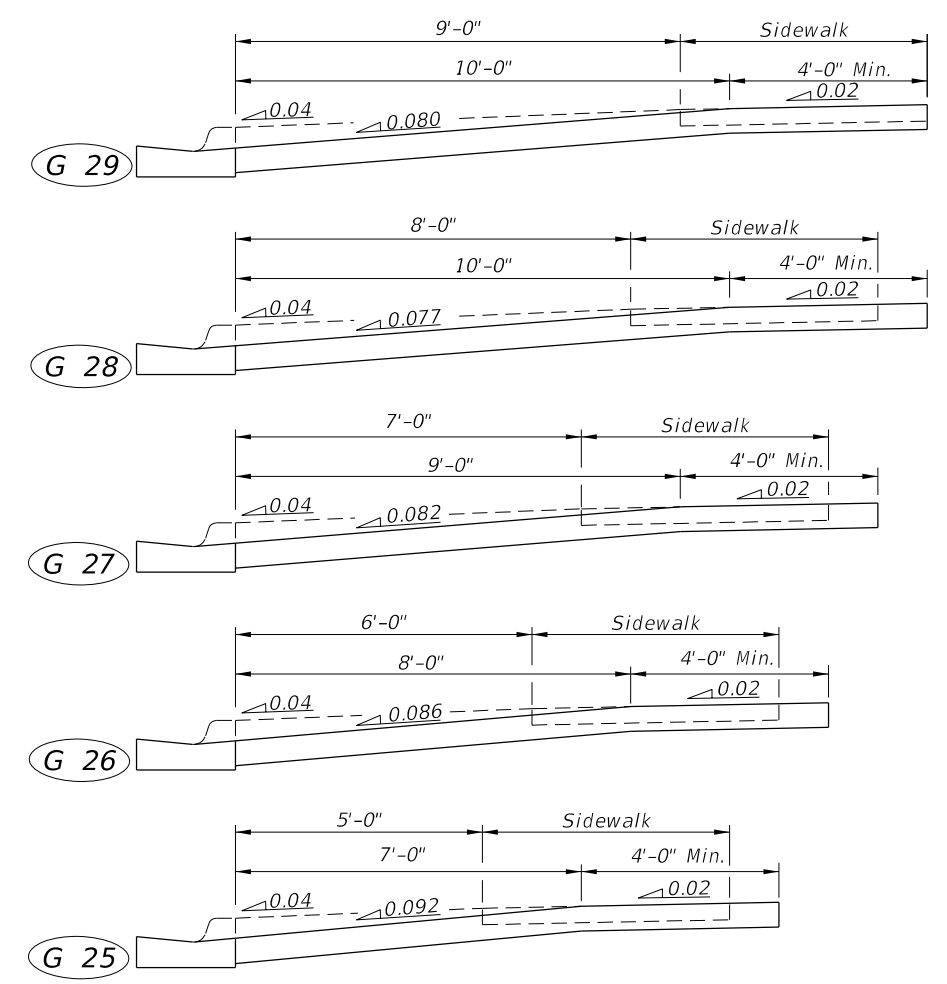
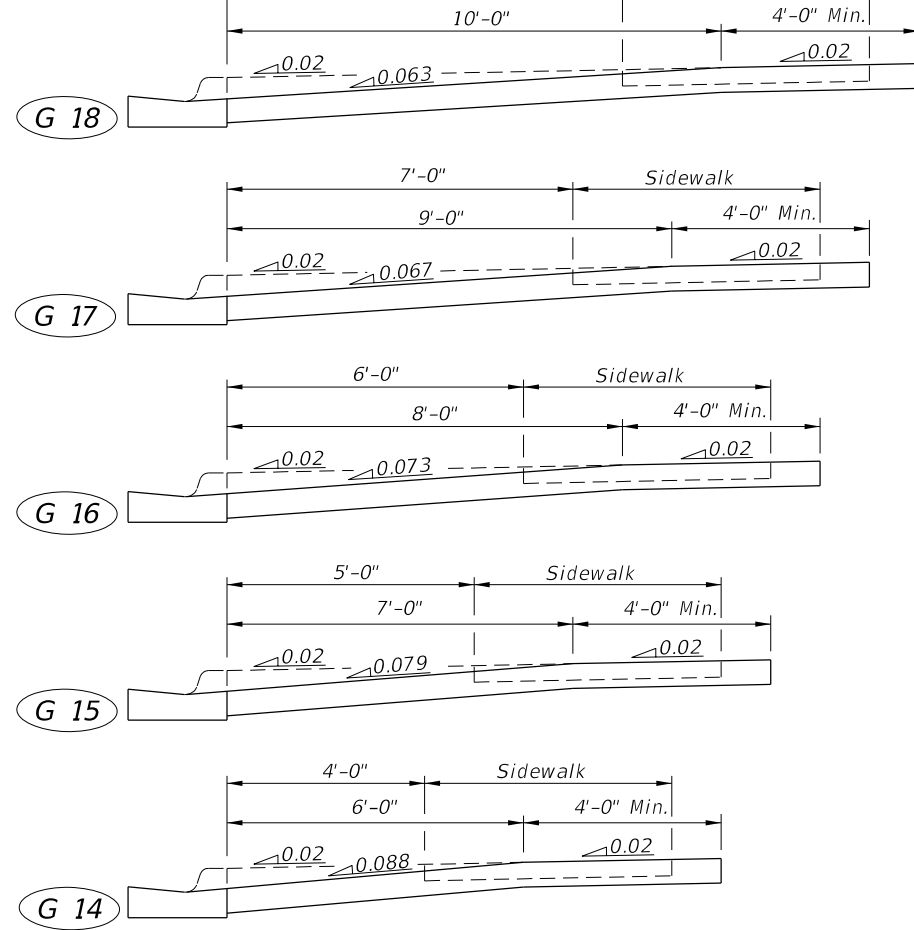
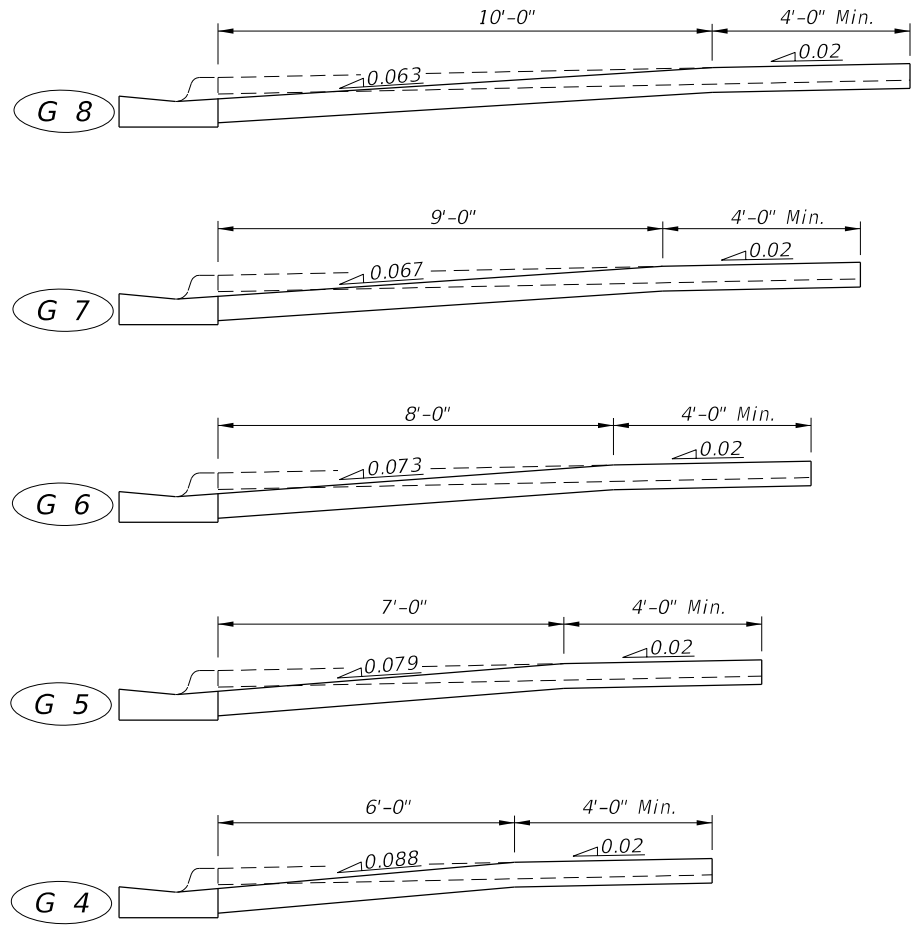

GENERAL APPLICATIONS

MARGINAL

ADVERSE

==== SIDEWALK WITHOUT UTILITY STRIP =====

==== SIDEWALK WITH UTILITY STRIP ON 0.02 SLOPE =====

==== SIDEWALK WITH UTILITY STRIP ON 0.04 SLOPE =====

NOTE:
5' sidewalks shown.

DRIVEWAY SECTIONS ON CURBED FACILITIES WITH SIDEWALKS

LAST REVISION 11/01/18	REVISION	DESCRIPTION:
---------------------------	----------	--------------



FY 2023-24
STANDARD PLANS

CONCRETE FLARED DRIVEWAYS

INDEX
522-003

SHEET
3 of 4

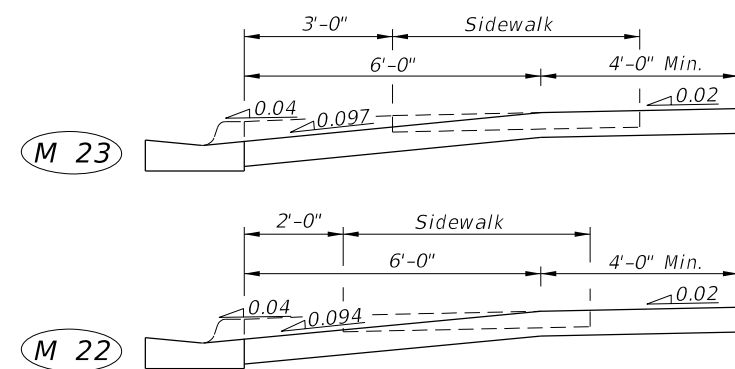
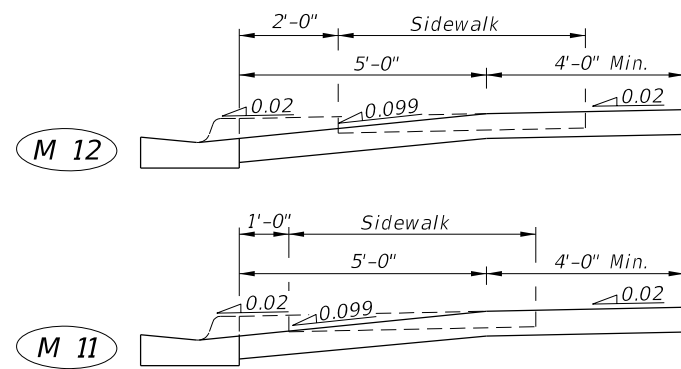
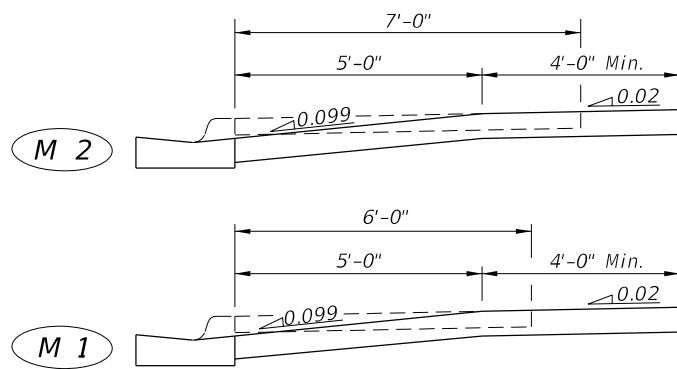
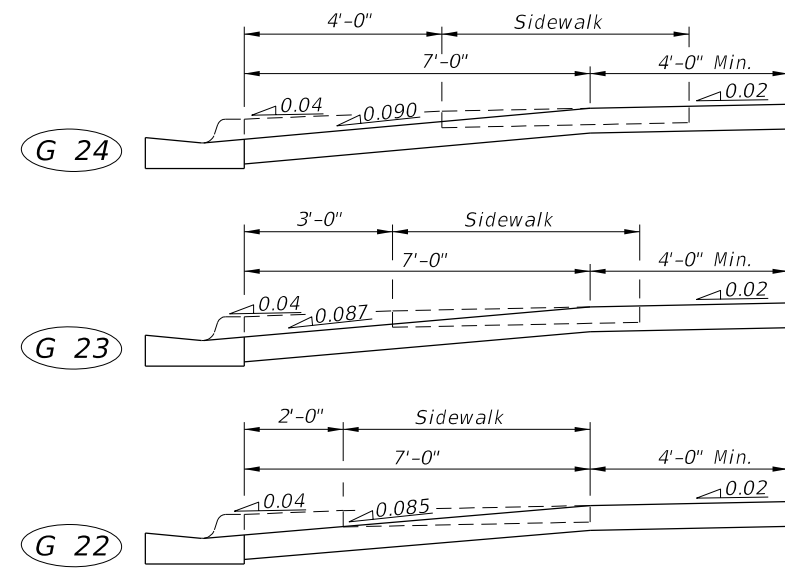
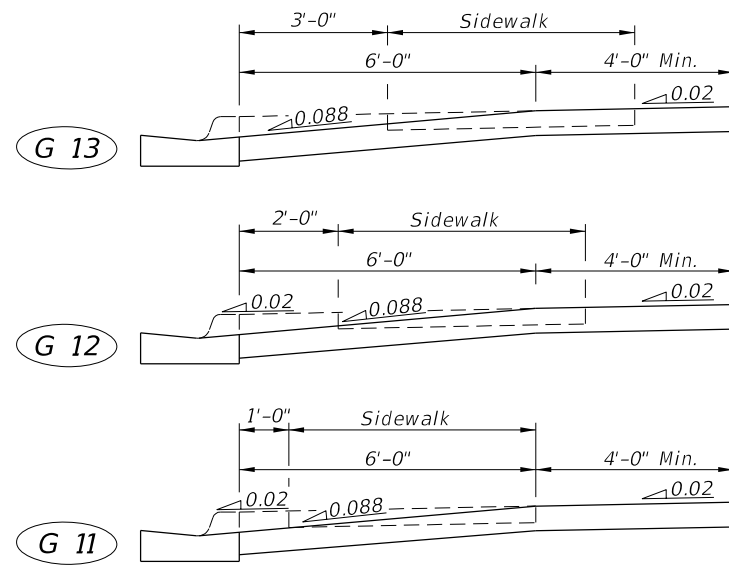
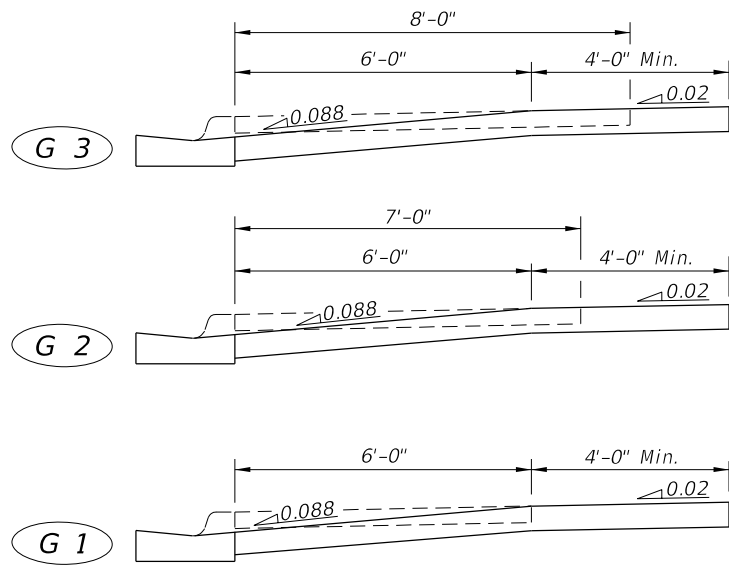

==== SIDEWALK WITHOUT UTILITY STRIP ====

==== SIDEWALK WITH UTILITY STRIP ON 0.02 SLOPE ====

==== SIDEWALK WITH UTILITY STRIP ON 0.04 SLOPE ====

NOTE:
5' sidewalks shown.

GENERAL APPLICATIONS

MARGINAL

DRIVEWAY SECTIONS ON CURBED FACILITIES WITH SIDEWALKS

LAST REVISION 11/01/18	REVISION	DESCRIPTION:
---------------------------	----------	--------------



CONCRETE FLARED DRIVEWAYS

INDEX 522-003	SHEET 4 of 4
------------------	-----------------

10/20/2022 8:52:33 AM

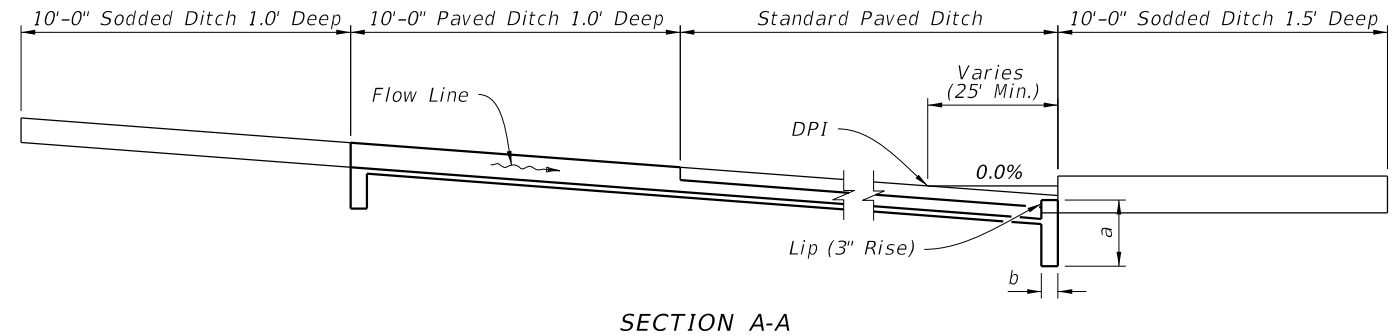
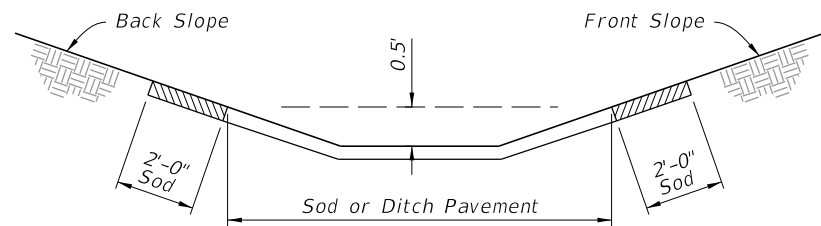
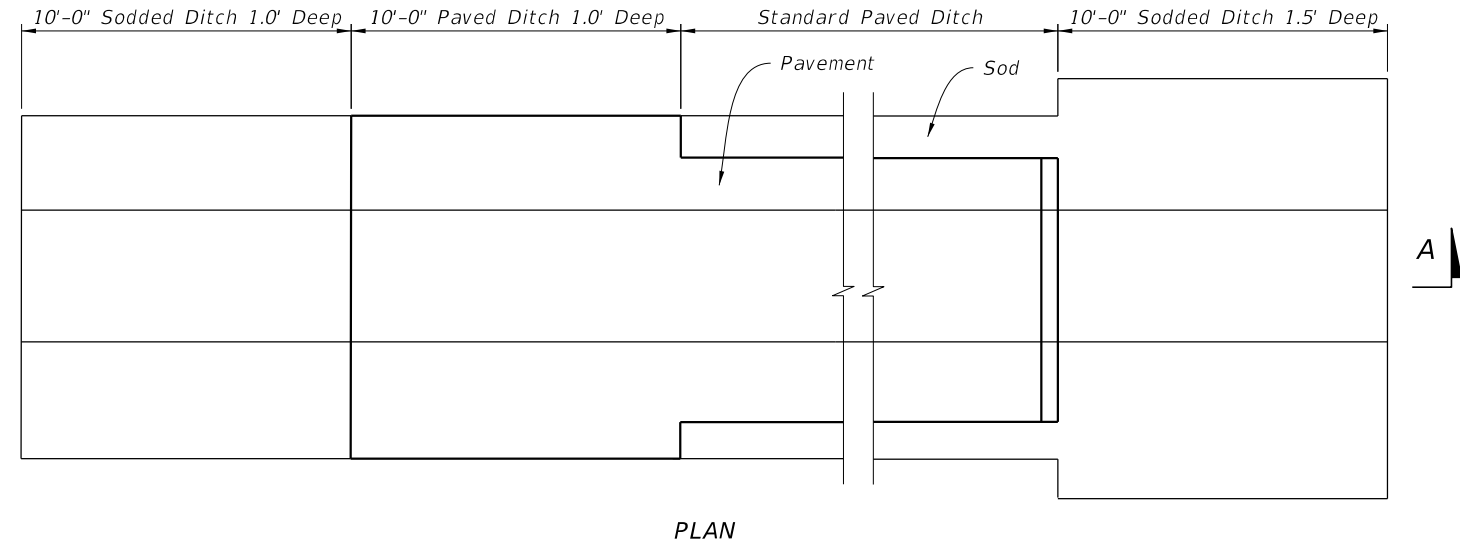
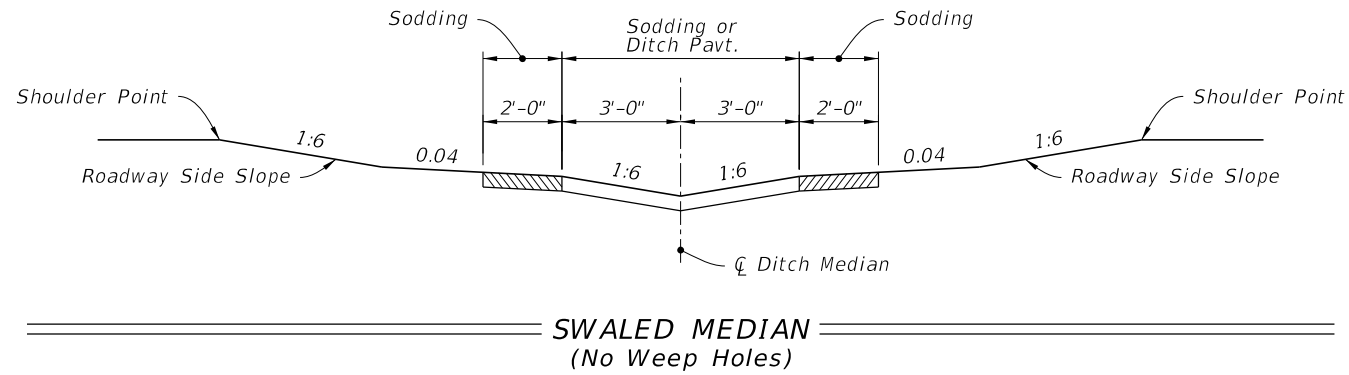

ROADWAY SIDE DITCH

PAVED DITCH END TREATMENT

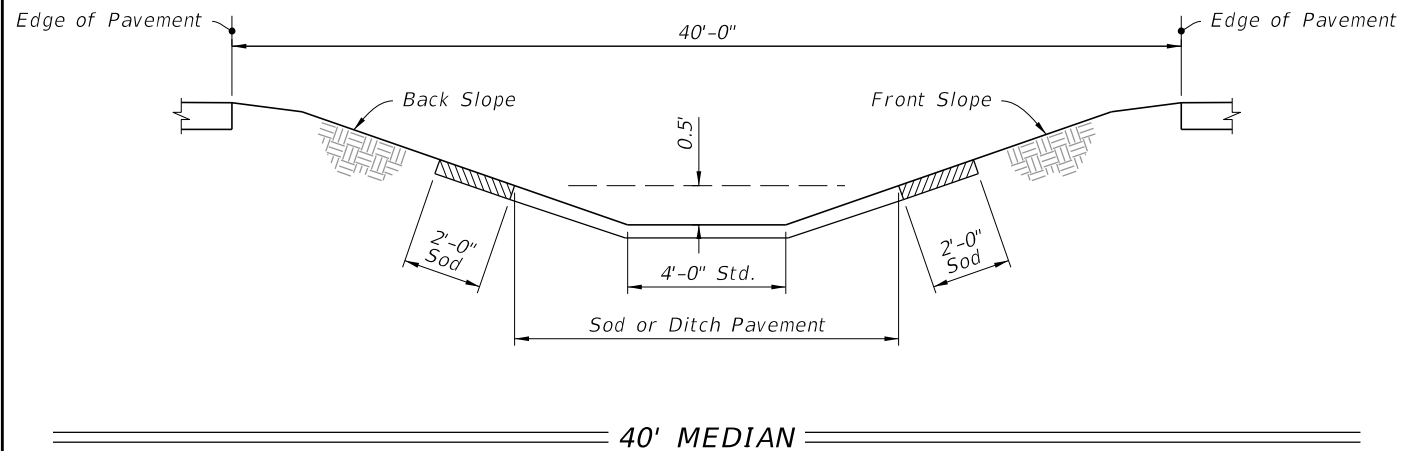

GENERAL NOTES:

1. Install type of ditch pavement shown on Plans.
2. Construct lip at the end of ditch pavement downstream of DPI or on flatter grades where there is a decrease in ditch velocity.
3. Use toewalls with all ditch paving, except adjacent to drainage structures.
4. Construct sides of paving with 1' minimum height for junction of R/W ditch spillway and lateral ditch.
5. Install filter fabric under all ditch pavement except for miscellaneous asphalt.
6. Install ditch pavement requiring reinforcement as detailed in Plans.

12/14/2023 3:13:22 PM

LAST REVISION 11/01/22	REVISION	DESCRIPTION:		FY 2023-24 STANDARD PLANS	DITCH PAVEMENT AND SODDING	INDEX 524-001	SHEET 1 of 3
---------------------------	----------	--------------	---	------------------------------	----------------------------	------------------	-----------------

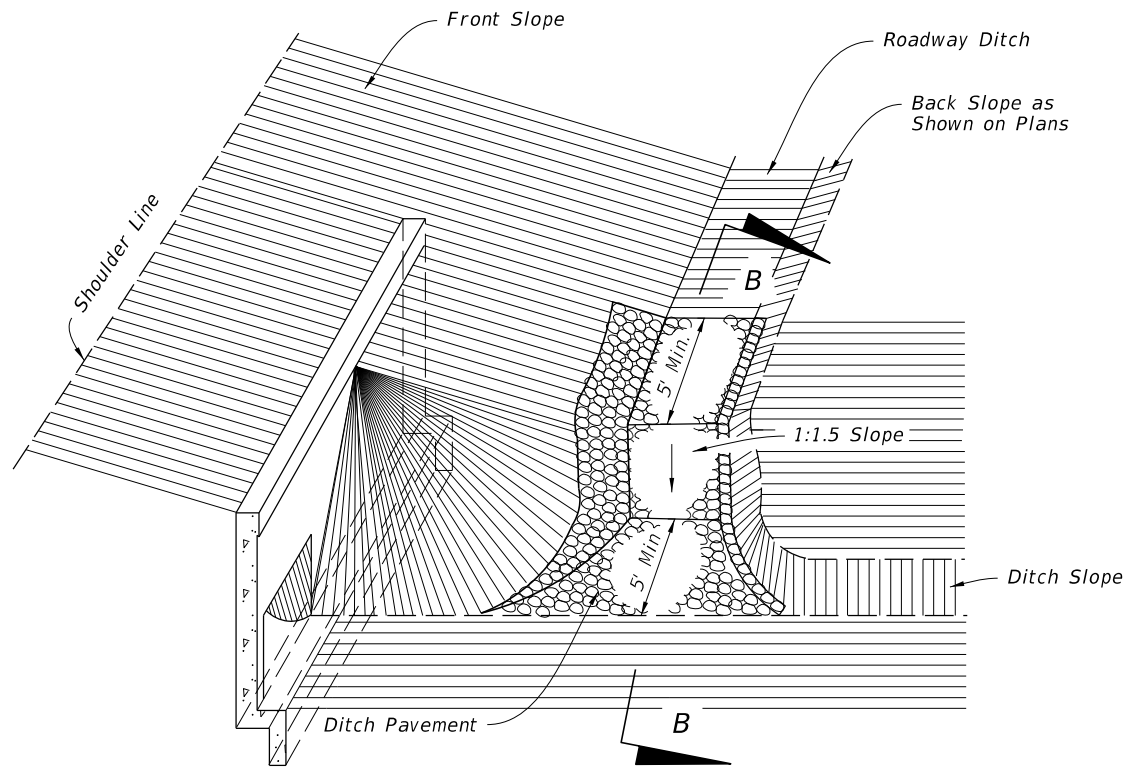

NOTE:
Miscellaneous asphalt will not be permitted for this type of construction.

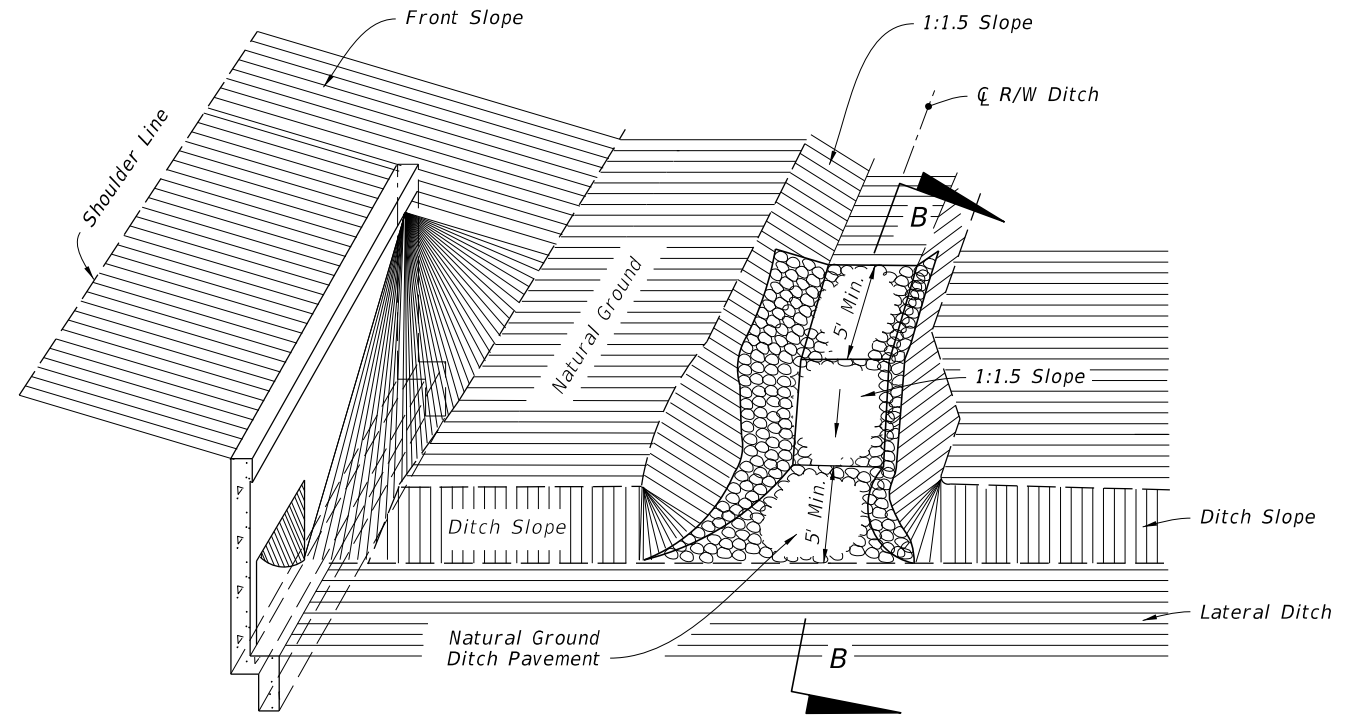

NOTE:
Miscellaneous asphalt will not be permitted for this type of construction.

JUNCTION OF ROADWAY DITCH AND LATERAL DITCH

JUNCTION OF R/W DITCH AND LATERAL DITCH

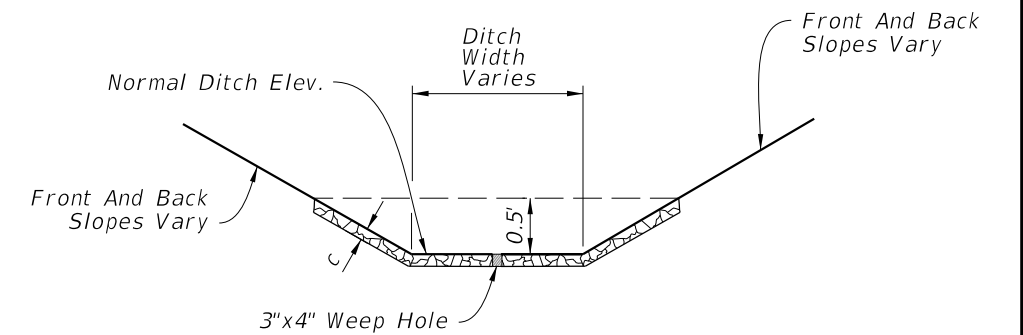
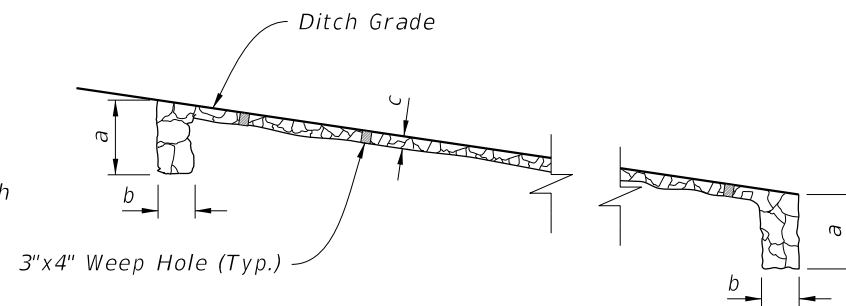
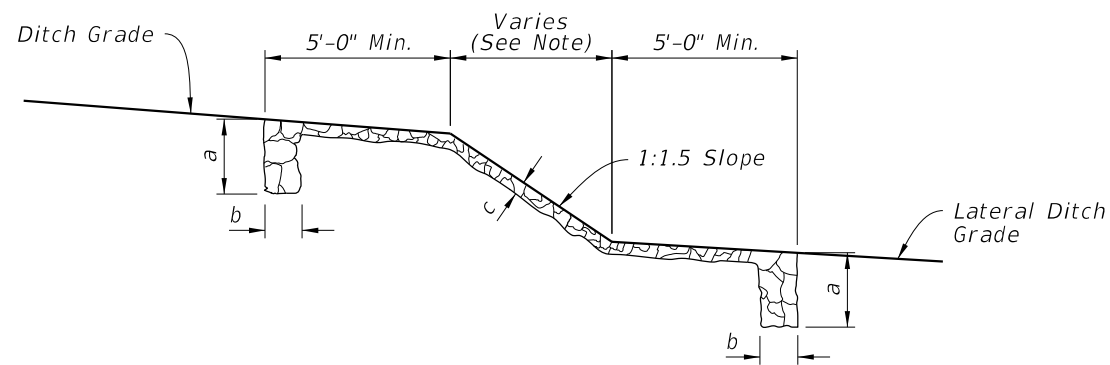

NOTE:
Do not construct weep holes in this area or 5' upstream

SECTION B-B
(As Shown)

SECTION B-B
(Locations Other Than Junction with Lateral Ditch)

TYPICAL SECTION

TABLE 1: DITCH PAVEMENT

Pavement Type	Dimensions			Filter Fabric Type	References & Remarks
	a	b	c		
Concrete	24"	6"	Varies	D-4	Specification 524
Miscellaneous Asphalt	24"	12"	4"	None	Specification 339
Riprap (Sand-Cement)	24"	12"	4"	D-4	Specification 530, Grouting of joints required
Riprap (Ditch Lining)	--	--	--	D-2	Specification 530

10/20/2022 8:52:34 AM

LAST REVISION 11/01/22	REVISION	DESCRIPTION:
---------------------------	----------	--------------

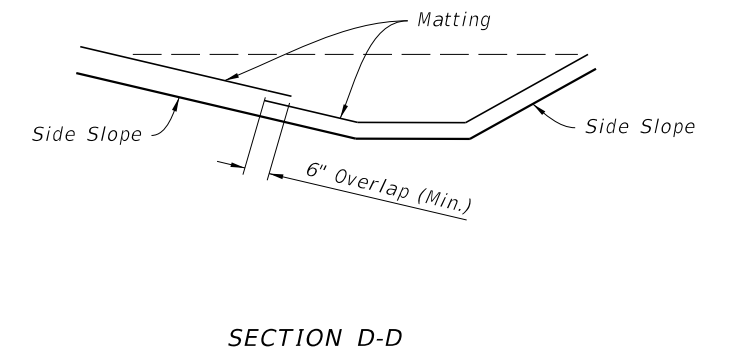
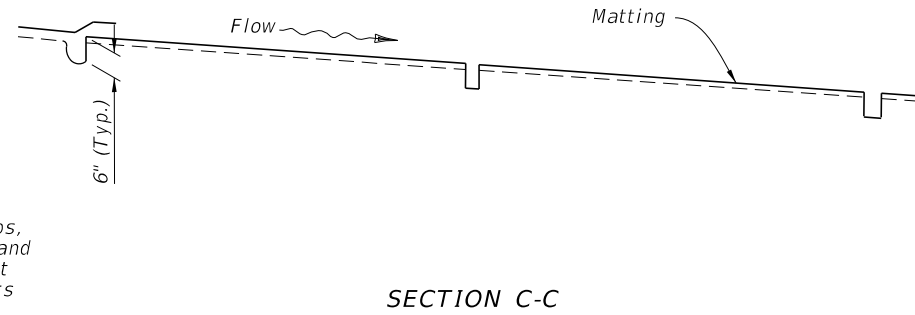
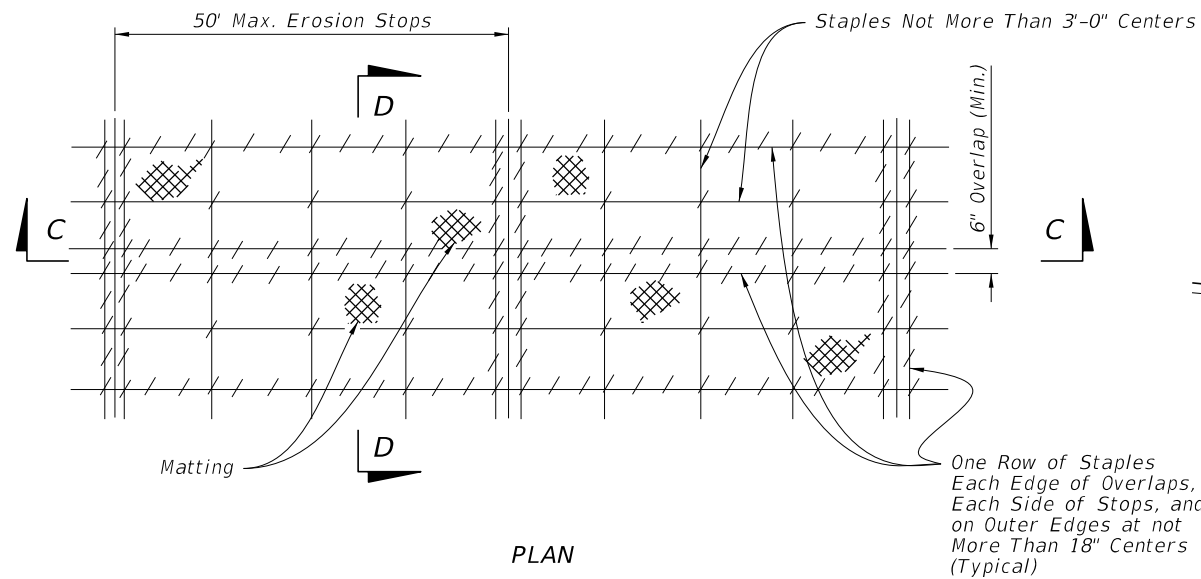

MATTING FOR DITCH

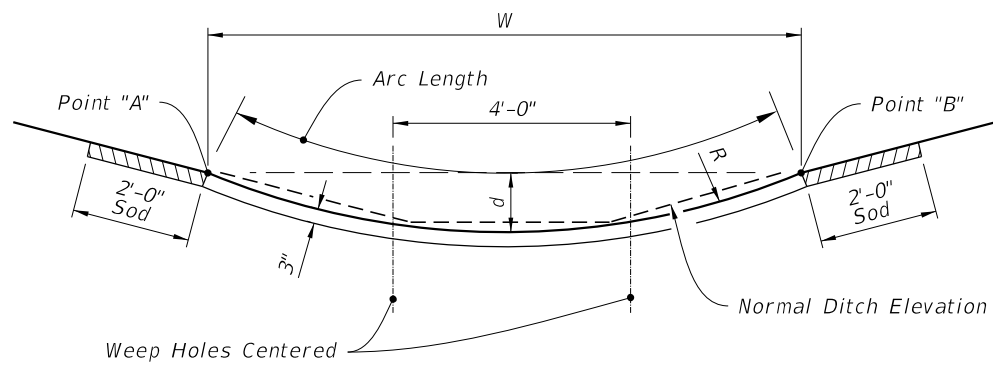
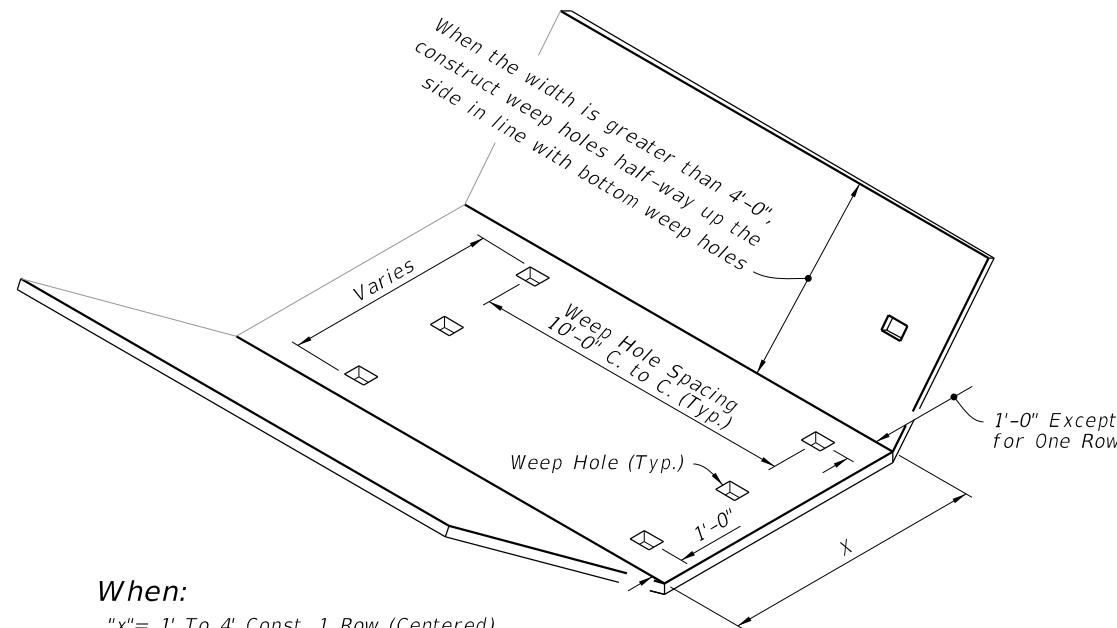

TABLE 2: ALTERNATE DITCH PAVEMENT					
TO REPLACE:	W	d	R	Rows Of Weep Holes	Arc Length
6' Median Swale	6'	0.24'	19'	0	6.0'
1:6 Front Slopes; 1:4 Back Slope					
5' Ditch Bottom Width	10'	0.67'	19'	2	10.1'
4' Ditch Bottom Width	9'	0.54'	19'	2	9.1'
1:4 Front Slopes & Back Slope					
5' Ditch Bottom Width	9'	0.74'	14'	2	9.2'
4' Ditch Bottom Width	8'	0.58'	14'	1 (in center)	8.1'

NOTE:
For use only where side slopes are 1:4 or flatter. Point "A" and "B" are at the same elevation and should be used to locate the paved section.



When:
 "x" = 1' To 4' Const. 1 Row (Centered)
 "x" = 5' To 7' Const. 2 Rows
 "x" = 8' To 12' Const. 3 Rows
 "x" = 13' To 17' Const. 4 Rows
 "x" = 18' To 22' Const. 5 Rows

- NOTES:**
- Construct all weep holes 3"x4" rectangle or 4" or 5" diameter circle hole. Place 1/2 cu. ft. (12" x 12" x 6") of No. 57 aggregate under each hole with 1 sq. ft. of galvanized wire mesh (1/4" openings) placed between the aggregate and the ditch pavement.
 - Rectangle weep holes shown, round weep holes similar.
 - Weep hole spacing may be reduced to 5' minimum when directed by the Engineer.

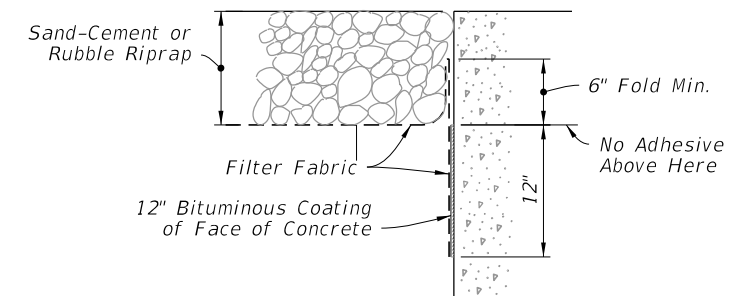

BONDED OPTION

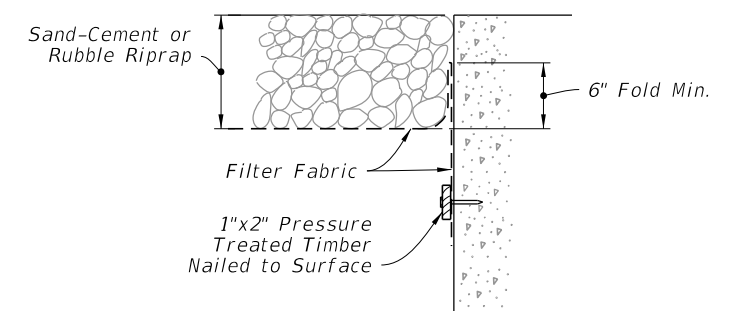

NAILED OPTION

NOTE:
Either option may be used, unless called for in the plans.

ALTERNATE DITCH PAVEMENT

WEEP HOLE ARRANGEMENT

FILTER FABRIC PLACEMENT AT CONCRETE STRUCTURE

10/20/2022 8:52:35 AM

LAST REVISION	DESCRIPTION:
11/01/22	



FY 2023-24
STANDARD PLANS

DITCH PAVEMENT AND SODDING

INDEX
524-001

SHEET
3 of 3

NOTES







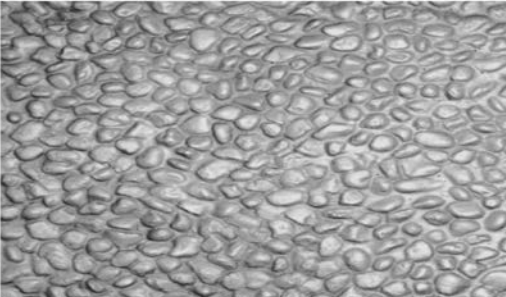
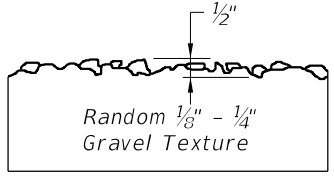

1. Work this Index with the Noise Wall Data Tables, and Wall Control Drawings in the Plans.
 - A. Prestressed concrete posts with equivalent strength resistance may be substituted for conventionally reinforced precast posts shown in this index when approved as part of a Producer's Quality Control Plan.
 - B. Producer shop drawings for prestressed concrete post designs must be approved by the State Structures Design Office prior to inclusion in the Quality Control Plan.
2. Construct Noise Walls in accordance with the requirements of Specification Section 534, and Augers Cast Piles in accordance with Specification Section 455.
3. Field verify the location of all overhead and underground services shown in the Wall Control Drawings.
4. Wall Height is the nominal height of the walls above finished grade. The Wall Embedment Depth for design is 1'-0". The actual embedment depth may vary plus or minus 6" along the length of the wall.
5. Post Spacing in this Index are nominal, and are measured from centerline to centerline of the auger cast piles. Actual post spacing may vary as shown in the Wall Control Drawings.
6. Panels:
 - A. The sum of the individual stacked panel heights is the Wall Height plus 1'-0" (embedment depth).
 - B. Where special graphics are required, locate the horizontal panel joints outside of the graphics. Where possible, hold horizontal panel joints at a constant elevation.
 - C. Side Installed Panels are only permitted when reduced overhead clearance between posts prohibits installing panels from the top.
 1. For Flush Face panels, install panel into posts from the back face of the wall. Recessed panels may be installed from the back or front face of the wall.
 2. After panels are installed and centered between posts, grout between both panel ends and the adjoining posts (see Sheets 4 and 5 for details).
 - D. Individual panel heights should be between 6'-0" and 12'-0" tall. The minimum panel height is 4'-0" and may be used where overhead clearance is limited, or where graphic panels are required on shorter walls.
7. Concrete And Grout:
 - A. Concrete Class and Compressive Strength for:
 1. Precast Panels, Posts, and Post Caps: Class IV
 2. Cast-In-Place Collars: Class IV
 - B. Minimum Compressive Strength for form removal and handling of posts and panels:
 1. 2,500 psi for horizontally cast post and panels
 2. 2,000 psi for vertically cast panels or when tilt-up tables are used for horizontally cast panels.
 - C. Grout for Auger Cast Piles:
 1. Maximum Working Compressive Strength = 2,000 psi
 2. Minimum 28 day strength = 5,000 psi
8. Reinforcing Steel:
 - A. In addition to the requirements of Specification Section 415, tie post and pile stirrups at the following locations as a minimum:
 1. Post Stirrups Tie at all four corner bars and at every third interior bar intersection.
 2. Pile Stirrups Tie to the main vertical reinforcing at alternate intersections for circular configurations and at the four corners and at every third interior bar intersection for rectangular configurations.
 - B. Provide 2" concrete cover unless noted otherwise.
9. Casting Tolerances for precast panels and posts:
 - A. Overall Height and Width: +/- 1/4"
 - B. Thickness: +/- 1/4"
 - C. Plane of side mold: +/- 1/16"
 - D. Openings: +/- 1/2"
 - E. Out of Square: 1/8" per 6 ft., but not more than 3/8" total along any side
 - F. Warping: 1/16" per foot distance to nearest corner
 - G. Bowing: 1/240 panel dimension
 - H. Surface Smoothness for Type "A" Smooth Surface Texture Option: +/- 1/16"
10. Provide Plain or Fiber Reinforced Bearing Pads meeting the requirements of Specification Section 932 for Ancillary Structures.
 - A. For Collar Bearing Points provide:
 1. 4"x 4"x 1/2" Fiber Reinforced Pads;
 2. Plain Pads may be substituted for Fiber Reinforced Pads when sufficient bearing area is available on the concrete collar for the following:
 - a. 10' Post Spacing: 4"x 4"x 1/2"
 - b. 20' Post Spacing and Wall Height < 17 feet: 4"x 4"x 1/2"
 - c. 20' Post Spacing and Wall Height ≥ 17 feet: 4"x 5"x 1/2"
 - B. At panel bearing points between stacked panels, use Plain or Fiber Reinforced Bearing Pads.

GENERAL NOTES

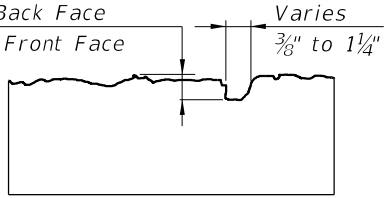
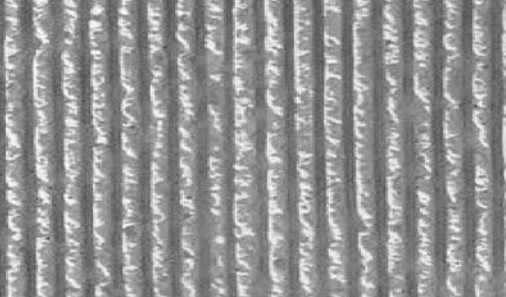
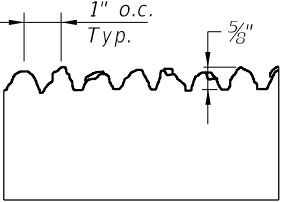
10/20/2022 8:52:36 AM

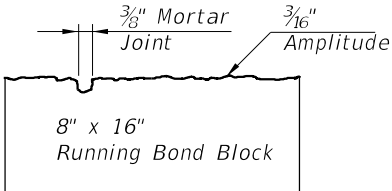
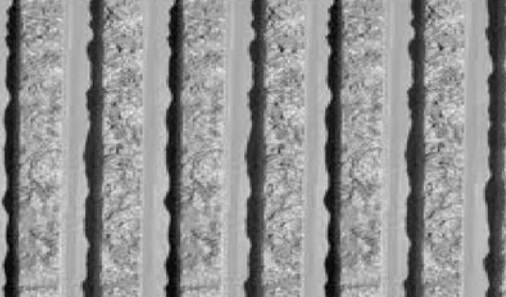
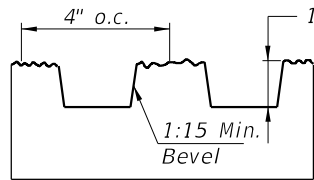
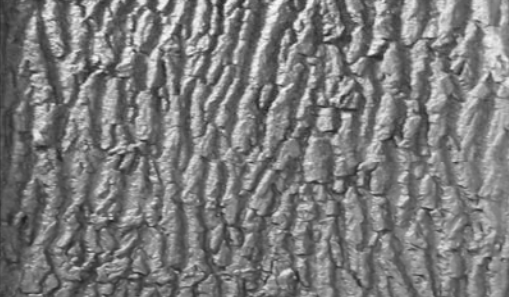
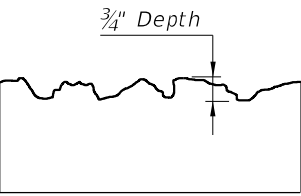
LAST REVISION 11/01/19	DESCRIPTION:	 FY 2023-24 STANDARD PLANS	NOISE WALLS - (PRECAST)	INDEX 534-200	SHEET 1 of 16
---------------------------	--------------	---	--------------------------------	------------------	------------------

10/20/2022 8:52:37 AM

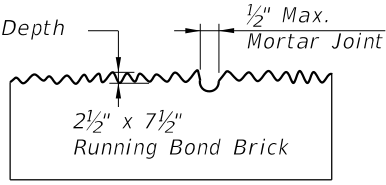
	<p>Type "A" SMOOTH</p>		<p>Type "F" PEA GRAVEL</p> 								
	<p>Type "B" ASHLAR STONE</p> 		<p>Type "G" VERTICAL FRACTURED FIN</p> 								
	<p>Type "C" SPLIT FACE RUNNING BOND BLOCK</p> 		<p>Type "H" TRAPEZOID VERTICAL FINNS W/ FRACTURED FACE (COLORADO DRAG AGGREGATE)</p> 								
	<p>Type "D" FRACTURED GRANITE</p> 		<p>Type "I" CUT CORAL BLOCK (RUNNING BOND)</p>  <p>Running Bond Block:</p> <table border="1" data-bbox="2209 1257 2660 1372"> <tr> <td>12" x (12", 14", 16" & 12")</td> <td>(1st course)</td> </tr> <tr> <td>6" x (21", 10" & 23")</td> <td>(2nd course)</td> </tr> <tr> <td>12" x (9", 10", 21" & 14")</td> <td>(3rd course)</td> </tr> <tr> <td>6" x (16", 14" & 24")</td> <td>(4th course)</td> </tr> </table>	12" x (12", 14", 16" & 12")	(1st course)	6" x (21", 10" & 23")	(2nd course)	12" x (9", 10", 21" & 14")	(3rd course)	6" x (16", 14" & 24")	(4th course)
12" x (12", 14", 16" & 12")	(1st course)										
6" x (21", 10" & 23")	(2nd course)										
12" x (9", 10", 21" & 14")	(3rd course)										
6" x (16", 14" & 24")	(4th course)										
	<p>Type "E" WIRE-CUT BRICK</p> 	<p>NOTES:</p> <ol style="list-style-type: none"> Surfaces shall be formed, rolled, or pressed using form liners in accordance with the Plans and Specifications for Class 3 Surface Finish. See Noise Wall Data Tables for project aesthetic requirements. 									

TEXTURE OPTIONS

<p>LAST REVISION 11/01/13</p>	<p>REVISION DESCRIPTION:</p>
-----------------------------------	------------------------------



FY 2023-24
STANDARD PLANS

NOISE WALLS - (PRECAST)

INDEX
534-200

SHEET
2 of 16

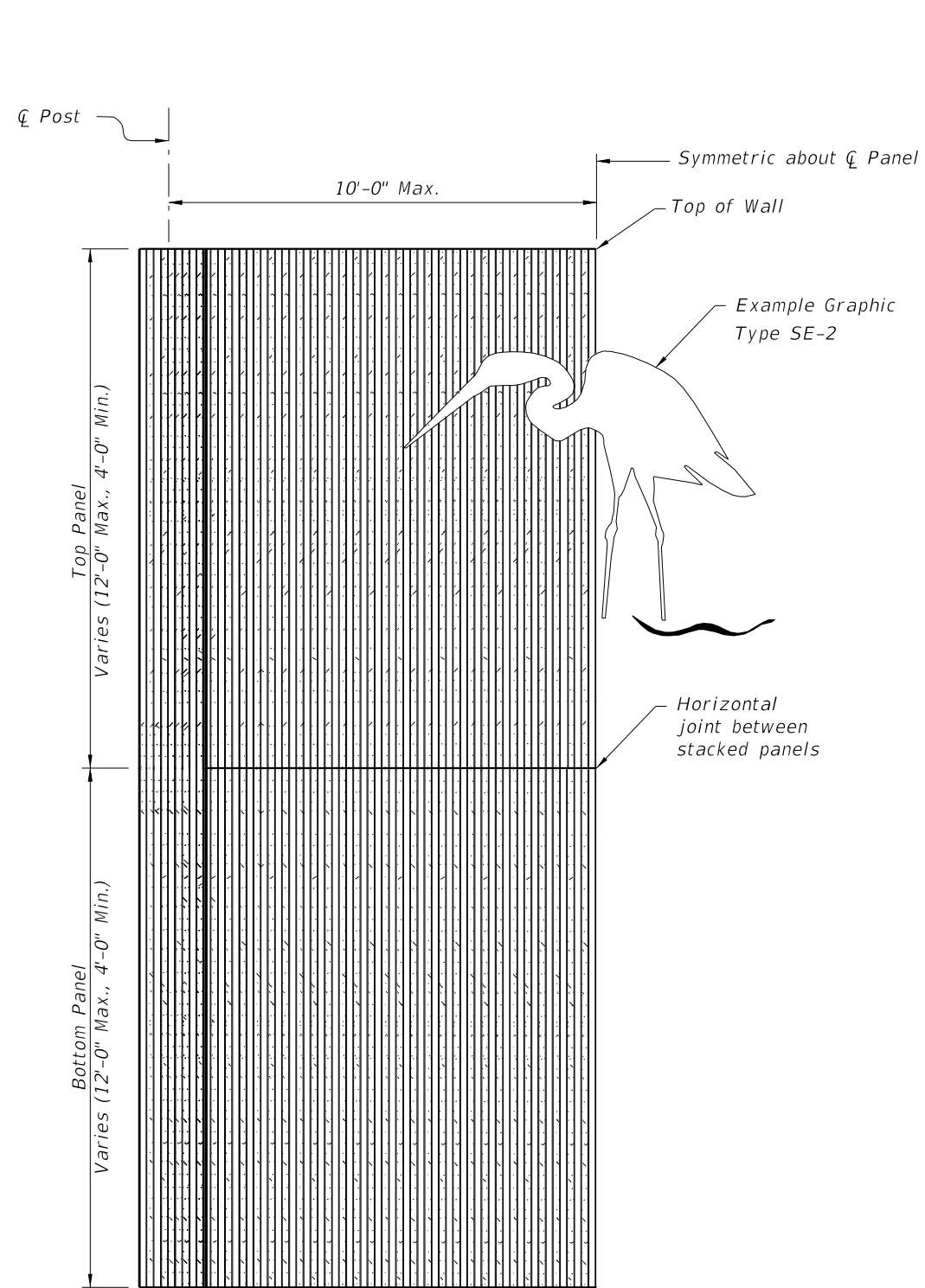

HALF ELEVATION
 (Front Face Post and Panel Texture Type "H" shown)
 (Graphic Type SE-2 shown)
 (Two stacked panels shown, three stacked panels similar)

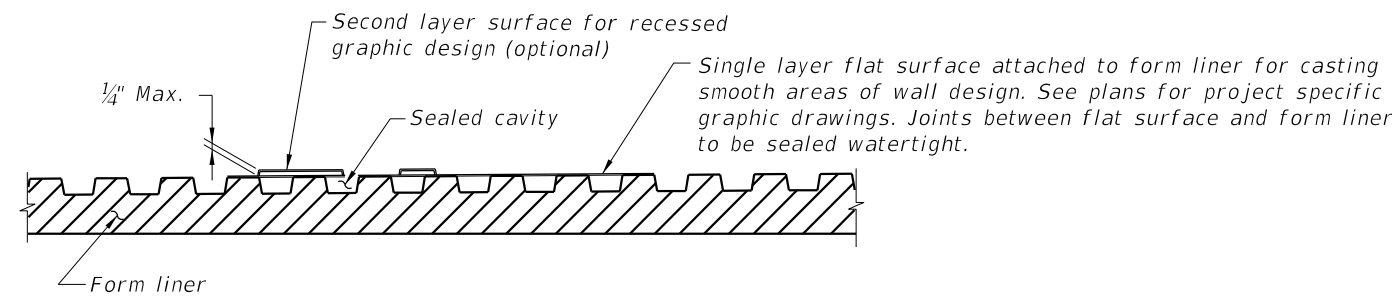
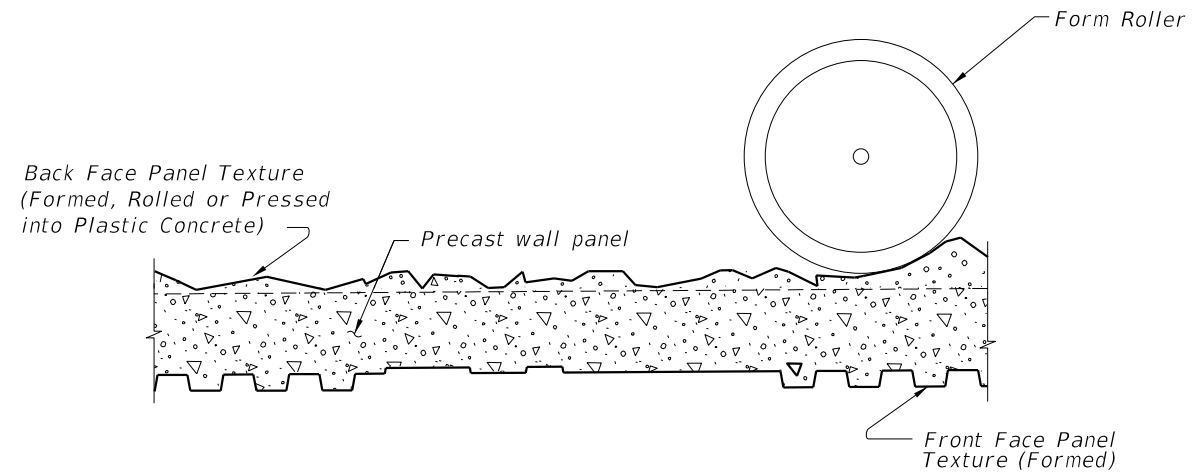

TYPICAL FORMING DETAIL
 (Front Face Panel Texture Type "H" shown)
 (Back Face Panel Texture Type "D" shown)
 (Post Forming Details Similar)

NOTES:

1. Submit specific form liner samples for approval by the Engineer.
2. Textures and graphics shown are for demonstration purposes only. See Noise Wall Data Tables in the plans for project specific texture and graphic requirements.

10/20/2022 8:52:38 AM

LAST REVISION 11/01/14	REVISION	DESCRIPTION:		FY 2023-24 STANDARD PLANS	NOISE WALLS - (PRECAST)	INDEX 534-200	SHEET 3 of 16
---------------------------	----------	--------------	---	------------------------------	-------------------------	------------------	------------------

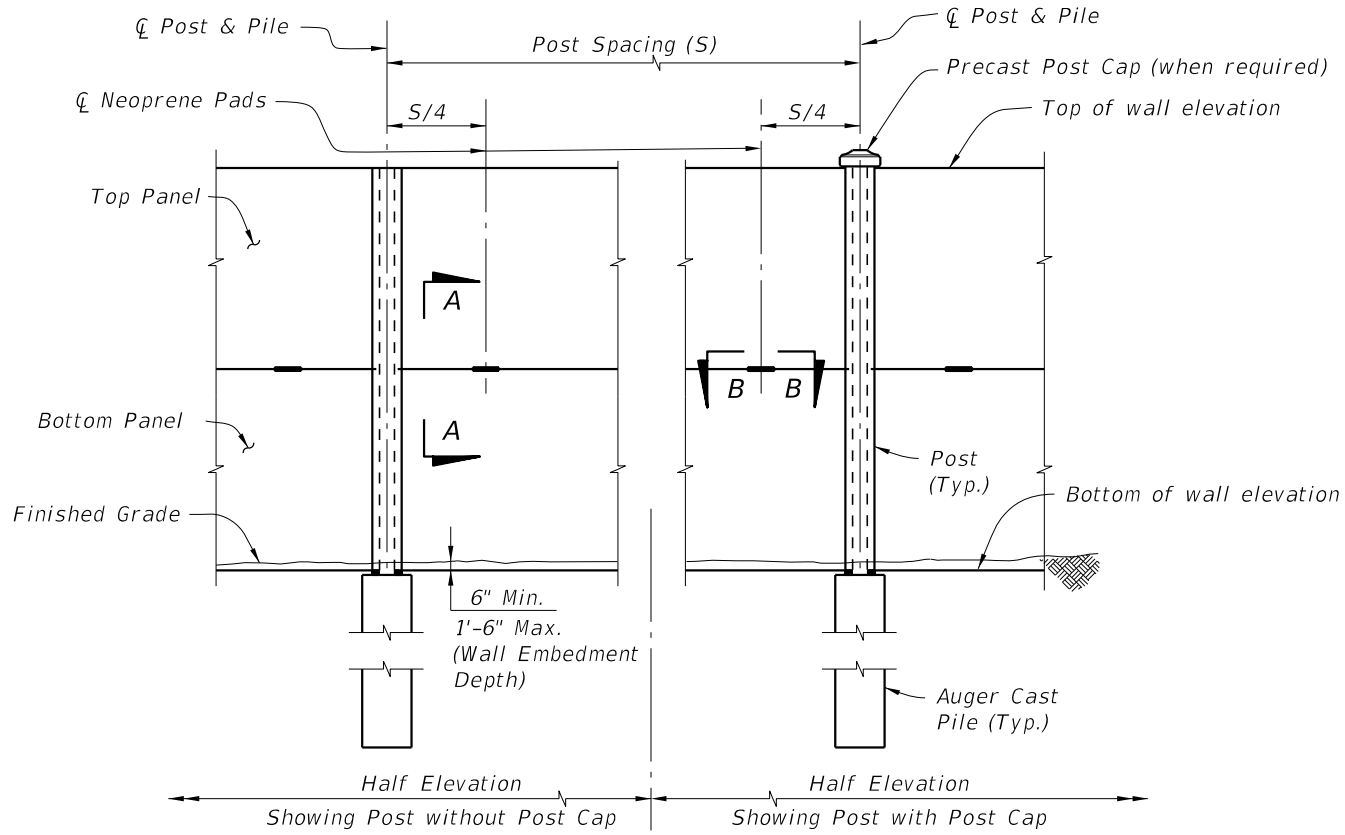

TYPICAL ELEVATION

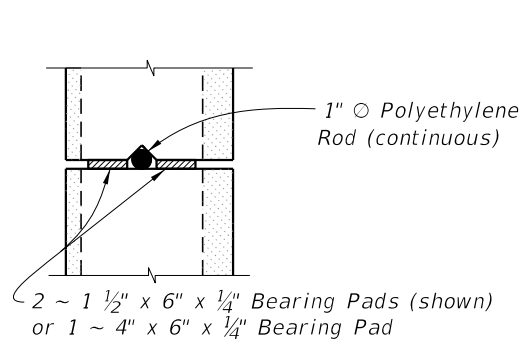

SECTION A-A

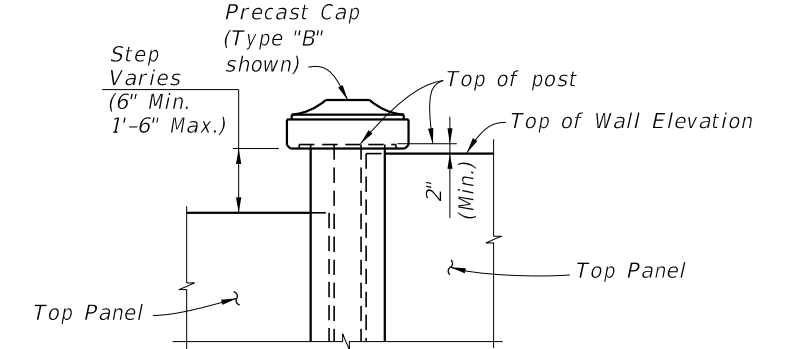

WITH POST CAP

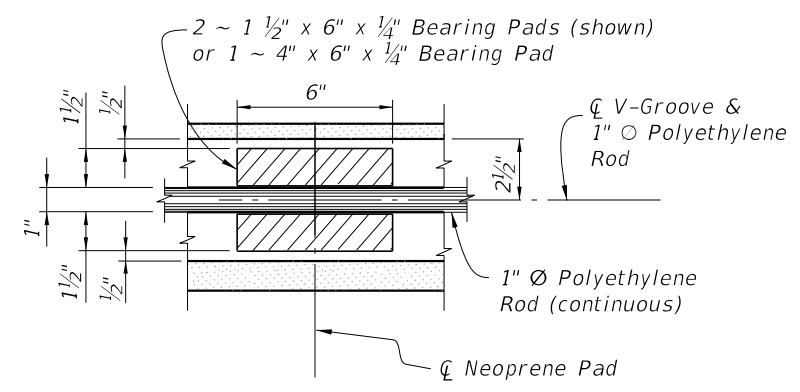

SECTION B-B

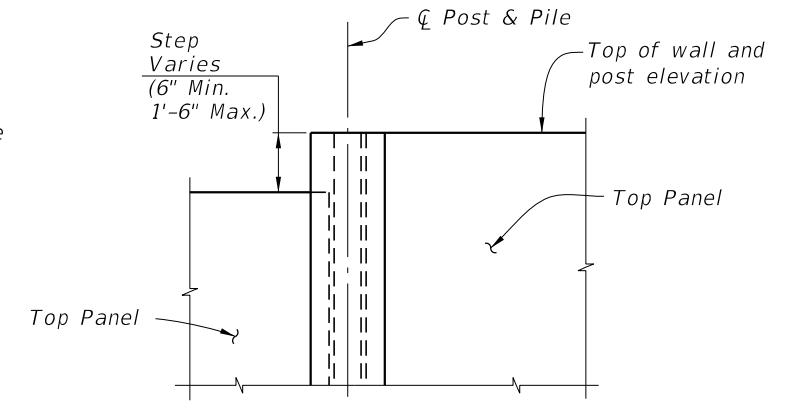

WITHOUT POST CAP

ELEVATION STEP AT TOP OF WALL

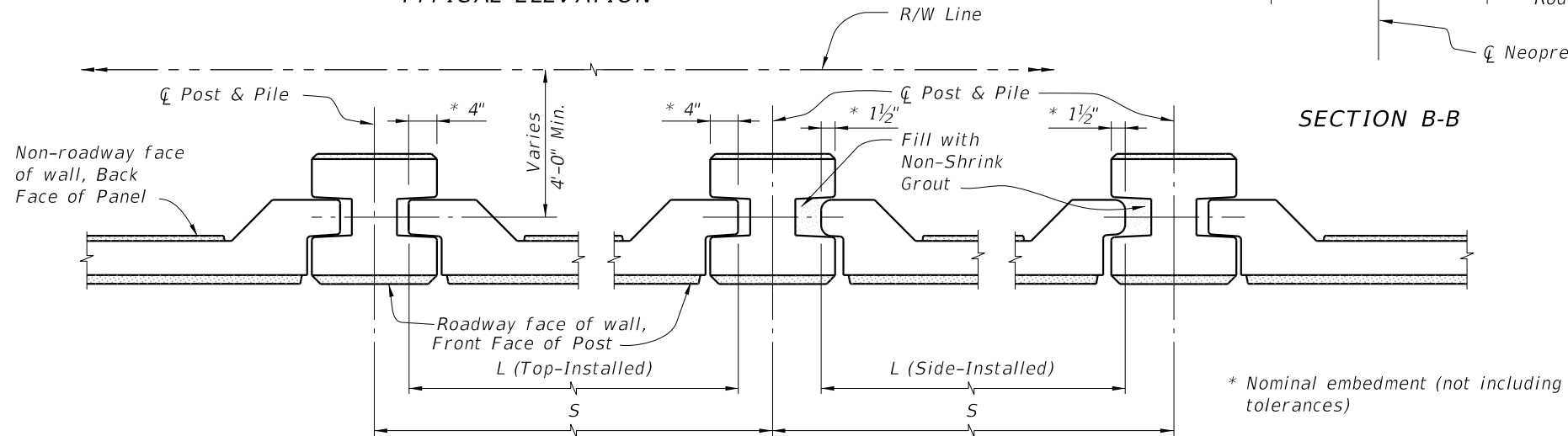

PLAN (Showing Flush Panel)

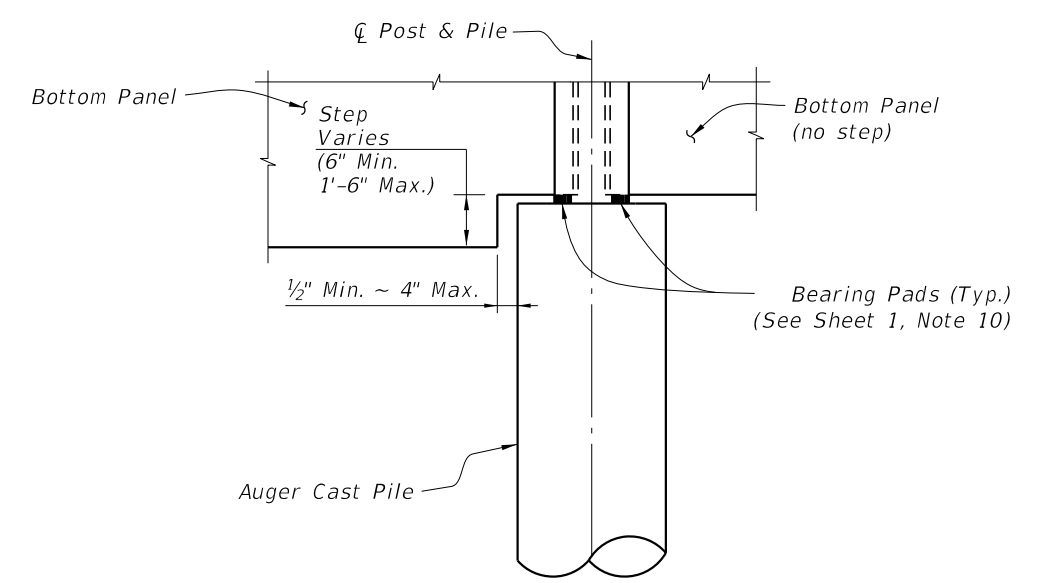

ELEVATION STEP AT BOTTOM OF WALL

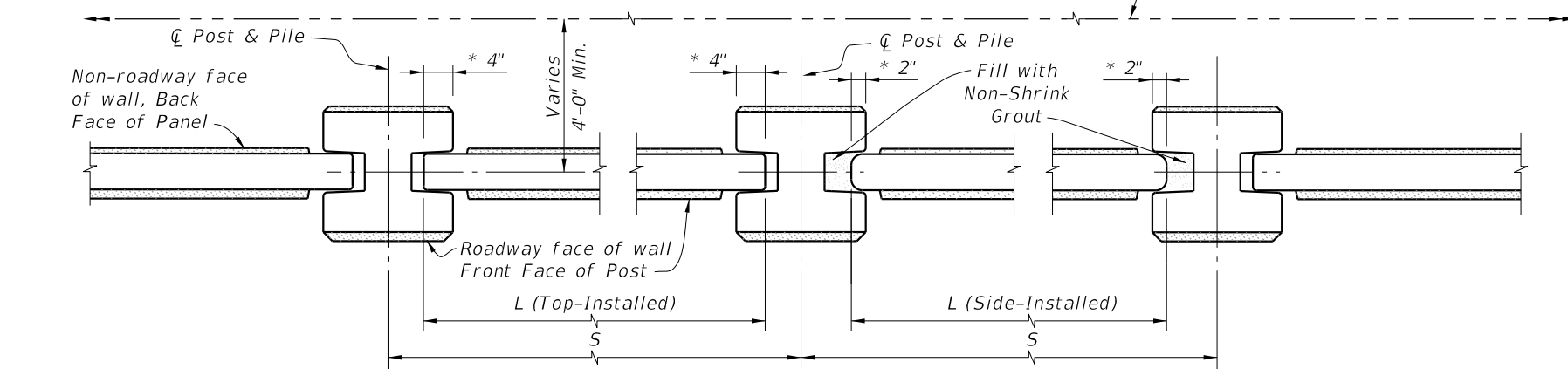

PLAN (Showing Recessed Panel)

Note:
See the plans for required post spacings (S).

TYPICAL DETAILS

10/20/2022 8:52:39 AM

LAST REVISION 11/01/16	DESCRIPTION:	 FY 2023-24 STANDARD PLANS	NOISE WALLS - (PRECAST)	INDEX 534-200	SHEET 4 of 16
---------------------------	--------------	--	-------------------------	------------------	------------------

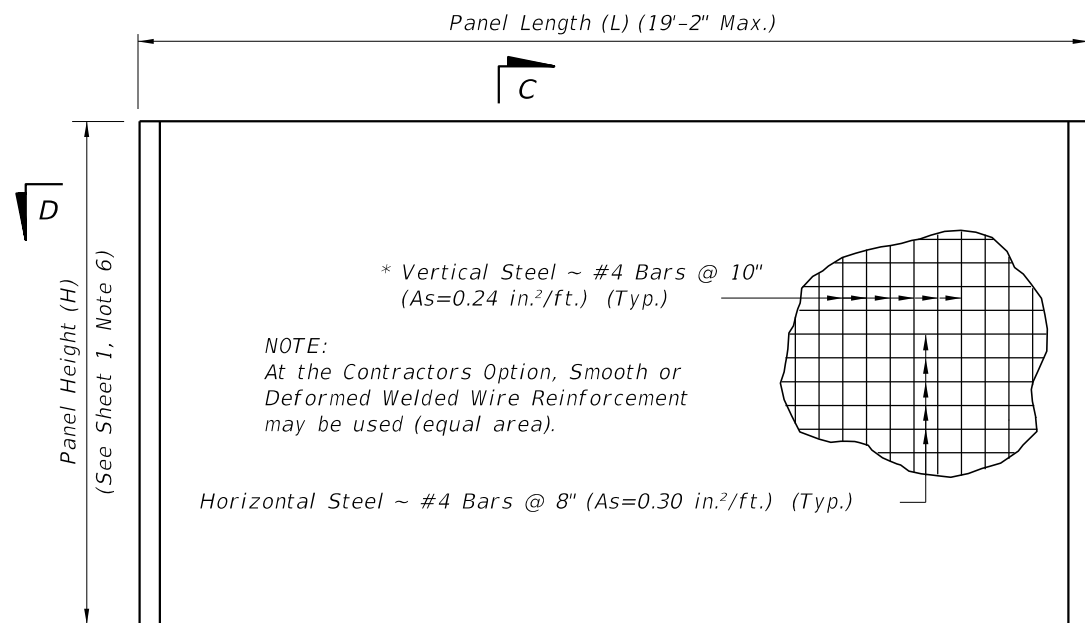

TYPICAL PANEL ELEVATION

* In lieu of utilizing the standard pick up points below, panels may be cast vertically or cast horizontally then tilted upright using tilt-tables prior to lifting from form. In this case, pick points must be placed in the top of panels only and transported maintaining the vertical orientation. If these criteria are met, the vertical steel may be reduced to #4 Bars @ 1'-3" (As=0.16 in.²/ft.).

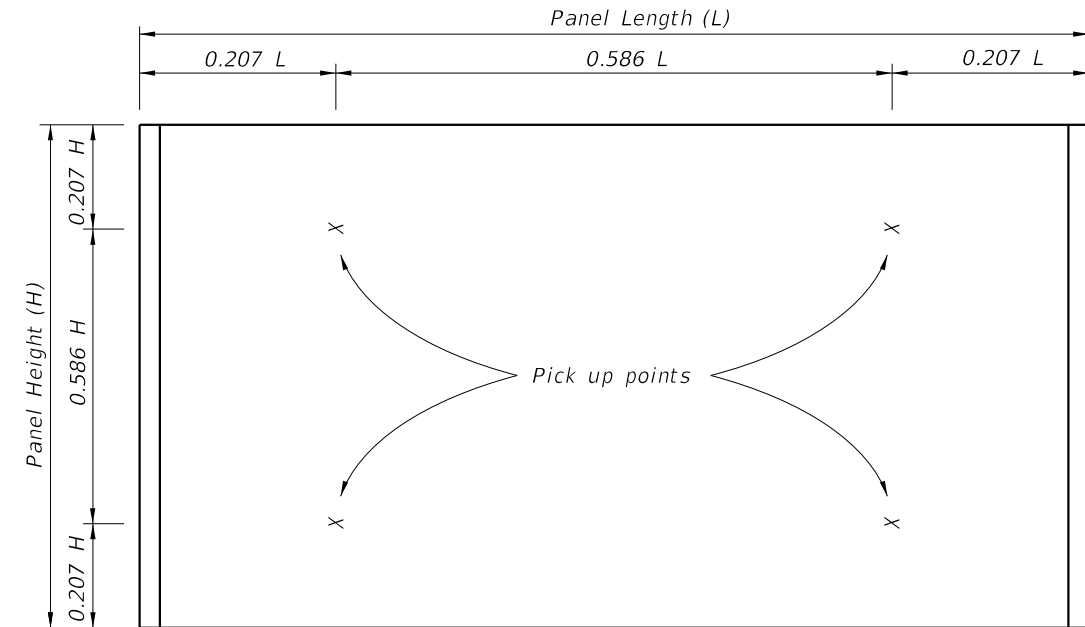

STANDARD PICK UP POINTS FOR PANELS
(Panels shall be rotated about long axis only)

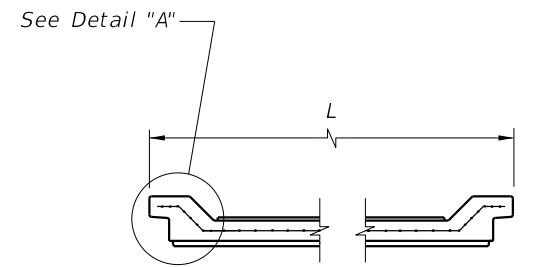

SECTION D-D
(Showing Flush Type Panel)

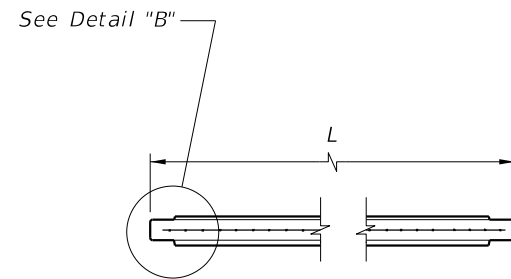

SECTION D-D
(Showing Recessed Type Panel)

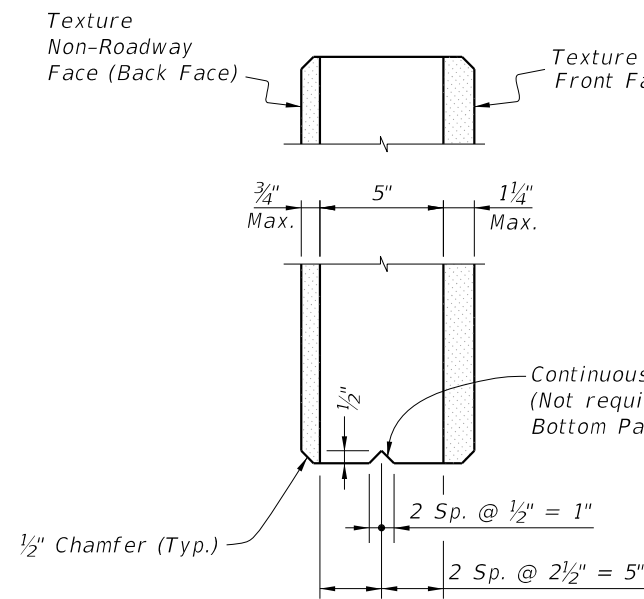

SECTION C-C

- Notes:
1. See Sheet 3 for allowable methods of applying textures.
 2. See plans for panel type and aesthetic requirements.
 3. For equal post spacing, side-installed panel length will be shorter than top-installed Panel length.

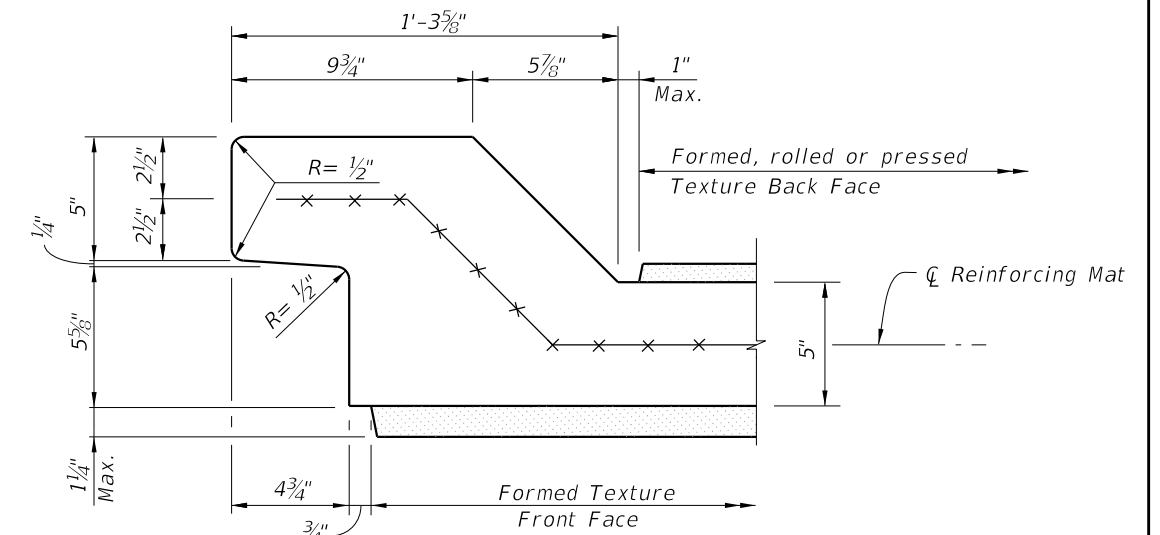

DETAIL "A" - TOP-INSTALLED
(Typical both ends)

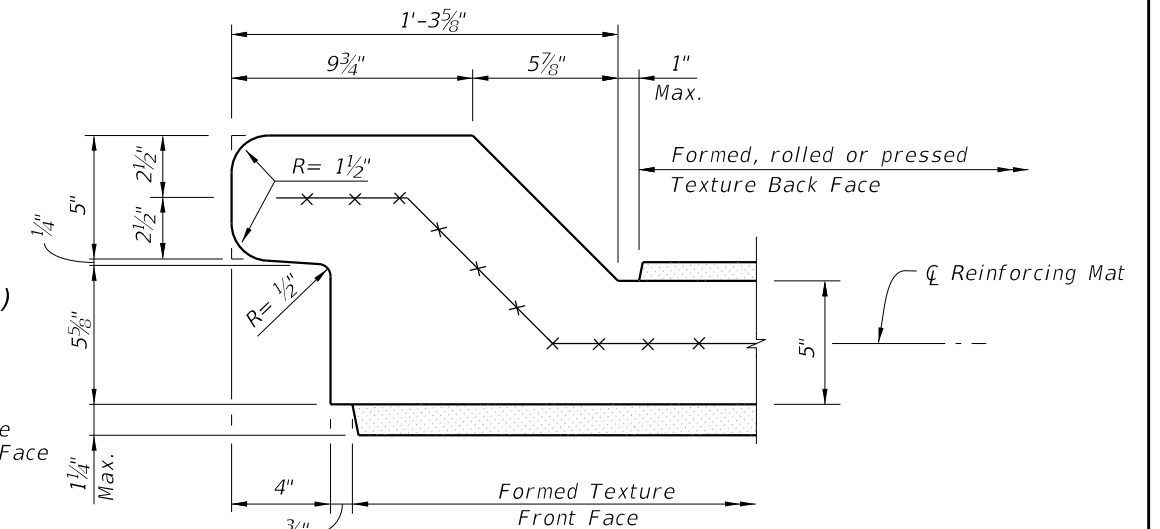

DETAIL "A" - SIDE-INSTALLED
(Typical both ends)

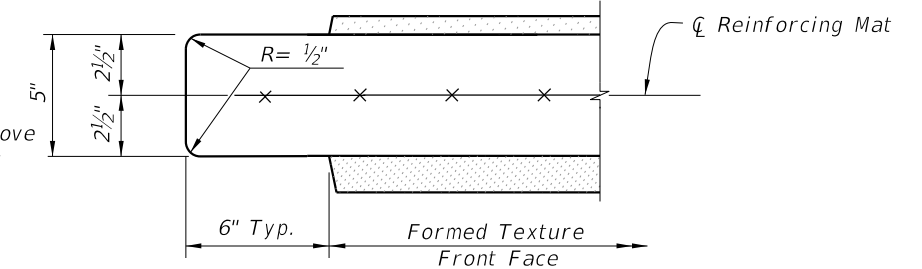

DETAIL "B" - TOP-INSTALLED
(Typical both ends)

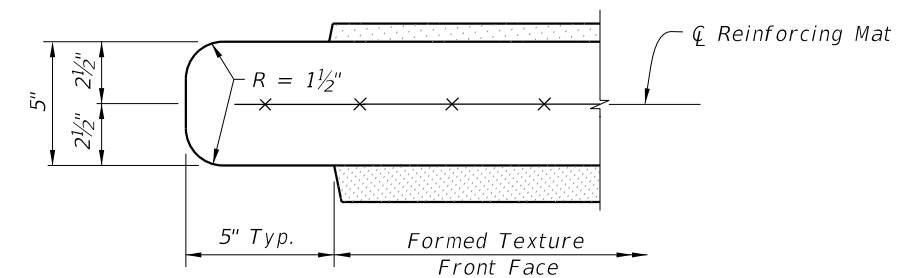

DETAIL "B" - SIDE-INSTALLED
(Typical both ends)

TYPICAL PANEL DETAILS

10/20/2022 8:52:40 AM

LAST REVISION	DESCRIPTION:
11/01/15	



FY 2023-24
STANDARD PLANS

NOISE WALLS - (PRECAST)

INDEX
534-200

SHEET
5 of 16

See Detail "C" for panel dimensions

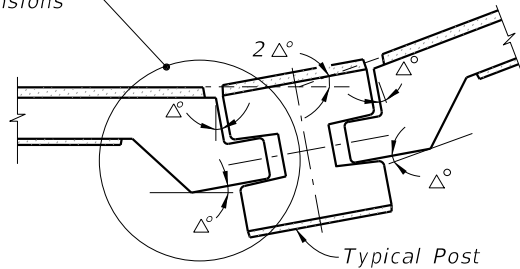

CASE 1
(Interior Angle)

See Detail "D" for panel dimensions

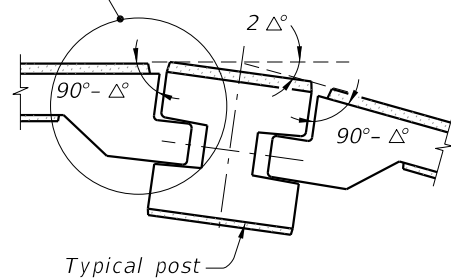

CASE 2
(Exterior Angle)

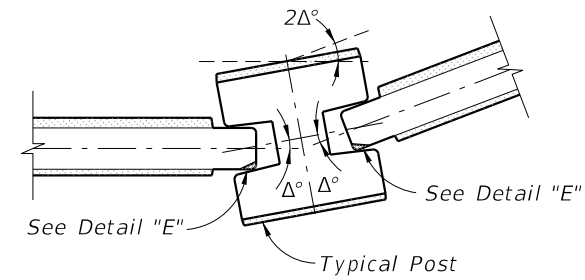

CASE 1
(Interior Angle)

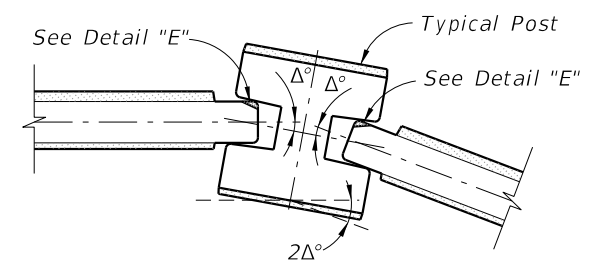

CASE 2
(Exterior Angle)

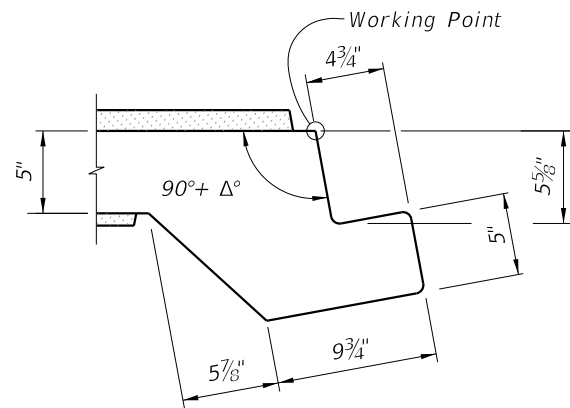

DETAIL "C"

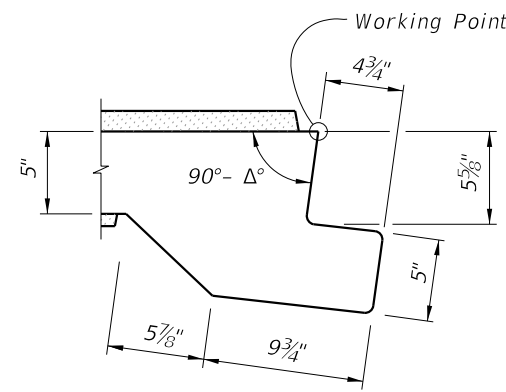

DETAIL "D"

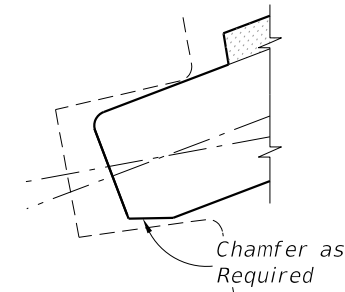

DETAIL "E"
(Back Face Chamfer Shown
Front Face Chamfer Similar)

NOTE:
The shop drawings shall include specific pivoting details of panel ends at locations where the deflection angle ($2\Delta^\circ$) between panels exceeds 7° .

NOTE:
The shop drawings shall include specific pivoting details of panel ends at locations where the deflection angle ($2\Delta^\circ$) between panels exceeds 20° .

PIVOTING DETAILS
(Flush Type Panel)

PIVOTING DETAILS
(Recessed Type Panel)

TYPICAL PANEL DETAILS

10/20/2022 8:52:41 AM

LAST REVISION 11/01/13	REVISION	DESCRIPTION:
---------------------------	----------	--------------



FY 2023-24
STANDARD PLANS

NOISE WALLS - (PRECAST)

INDEX
534-200

SHEET
6 of 16

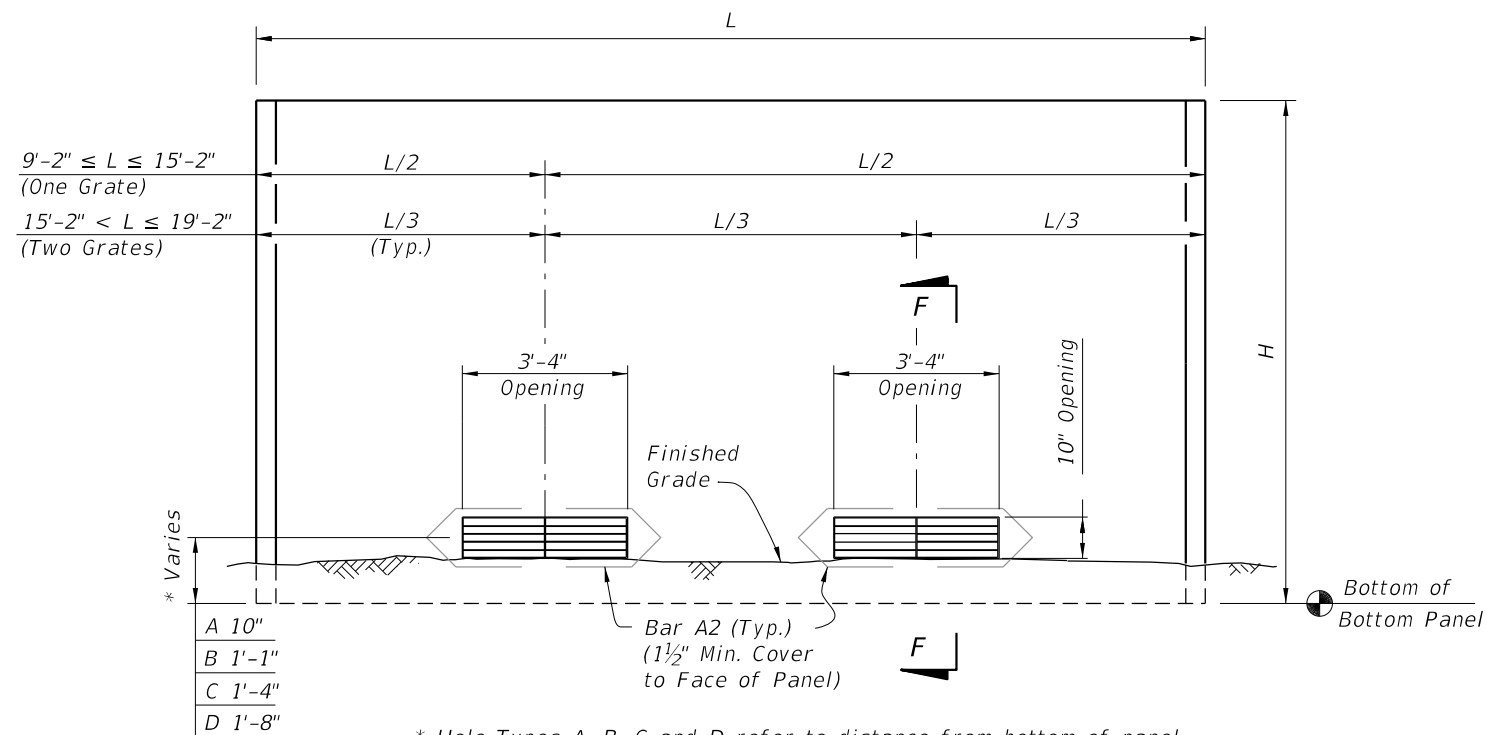

* Hole Types A, B, C and D refer to distance from bottom of panel to center of opening. See Wall Control Drawings in the plans.

DRAINAGE HOLES TYPES A, B, C & D
(Front Face of Wall Shown)
(Two Holes Shown,
One Hole Similar)

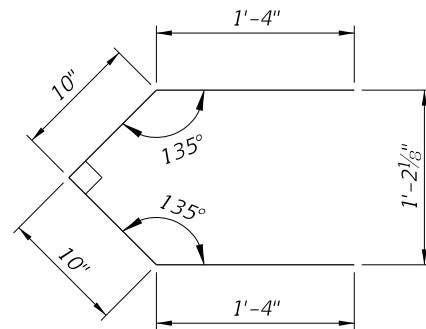

BAR A2 (Pair)
Bar Length = 4'-4"

BAR BENDING DETAILS (#3 Bars)

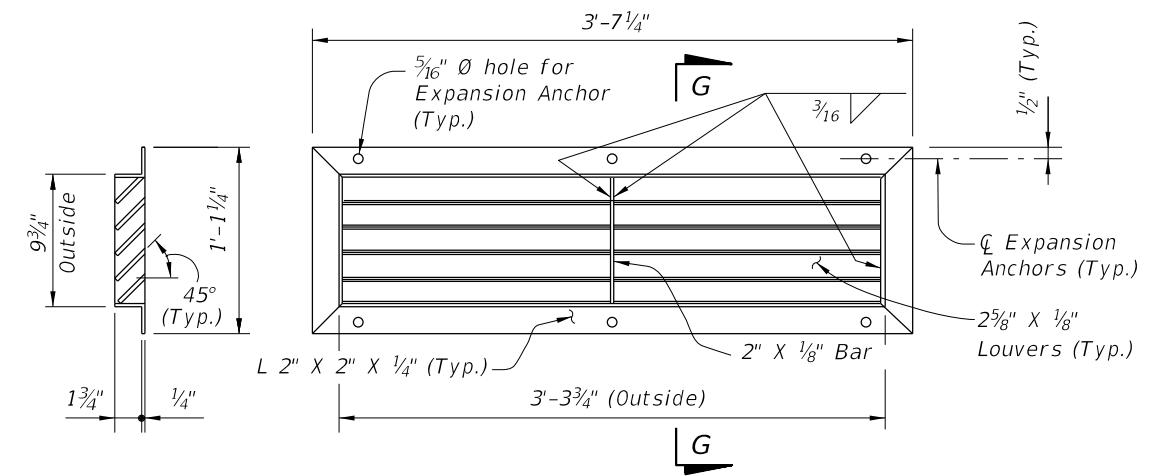

SECTION G-G

GRATING DETAIL

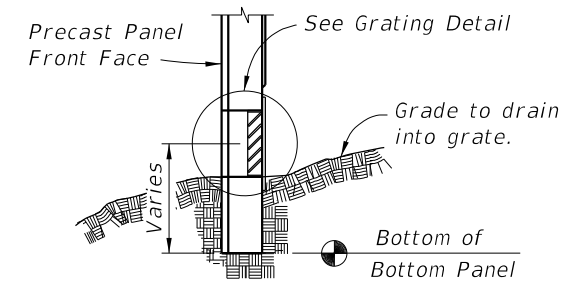

SECTION F-F

GRATING NOTES:

1. Grating shall be ASTM A36 steel welded in accordance with the current edition of ANSI/AWS D1.1 Steel Welding Code. Hot-dip galvanize grate after fabrication in accordance with Specification Section 962.
2. Expansion Anchors: Use 1/4" Ø x 2" min. corrosion resistant (zinc/aluminum alloy or stainless steel) expansion anchors to connect grates to panels.
3. Blockout textured concrete surface for a strip 2" wide around drainage hole to enable secure attachment of the drainage grate.

DRAINAGE HOLE DETAILS

10/20/2022 8:52:42 AM

LAST REVISION 11/01/17	DESCRIPTION:		FY 2023-24 STANDARD PLANS	NOISE WALLS - (PRECAST)	INDEX	SHEET
					534-200	7 of 16

10/20/2022 8:52:43 AM

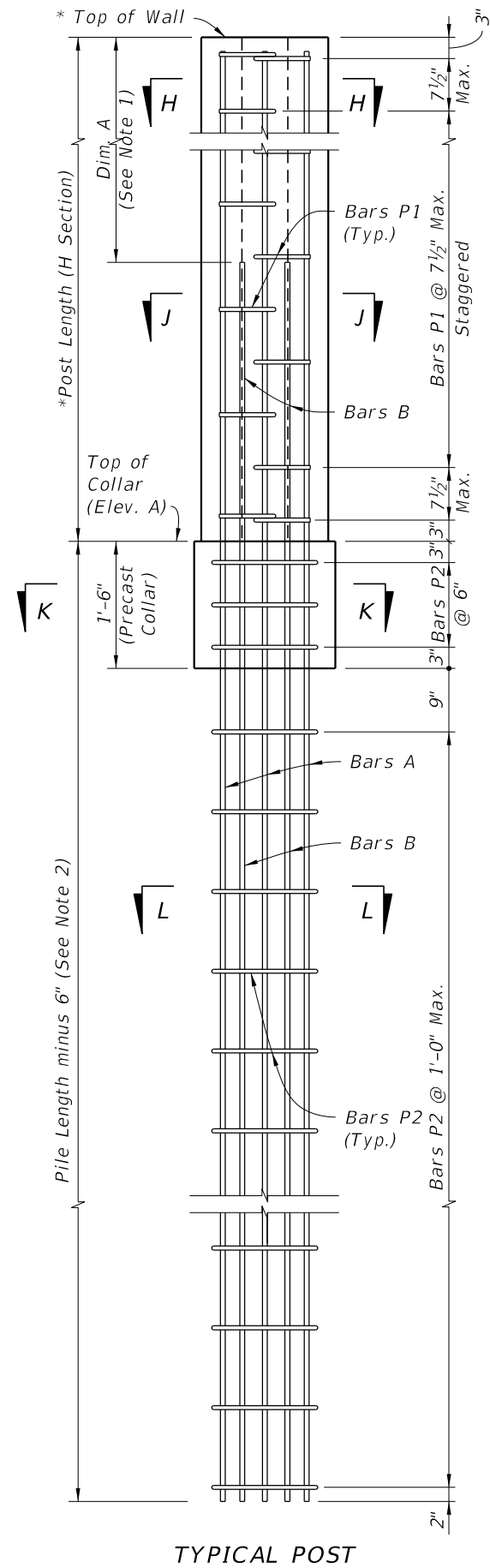

TYPICAL POST

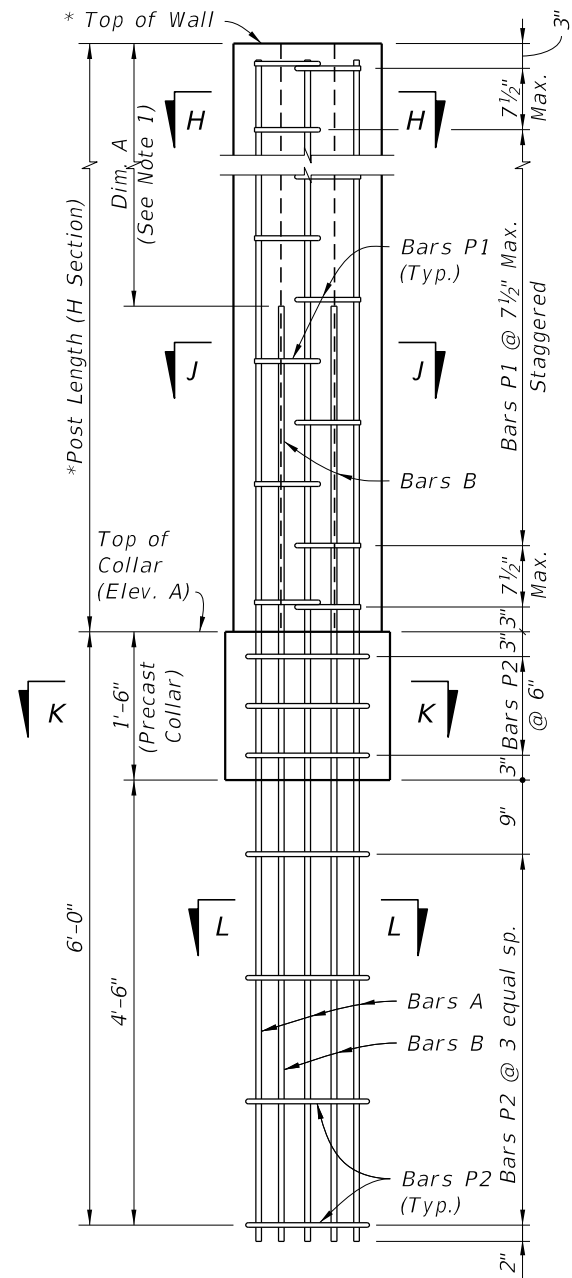

LOW CLEARANCE OPTION

* Extend Post 2" above top of high side wall panel when post caps are shown in plans. See Sheet 4, "ELEVATION STEP AT TOP OF WALL".

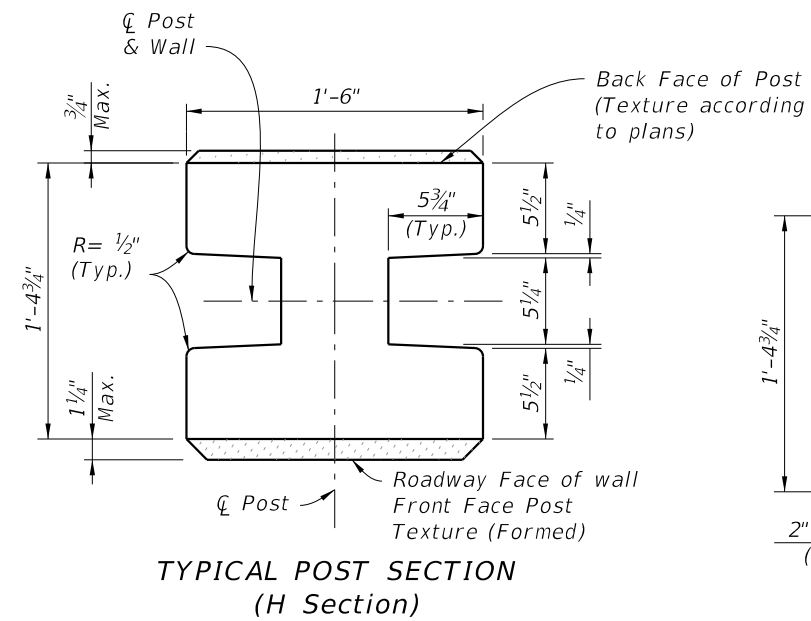

TYPICAL POST SECTION (H Section)

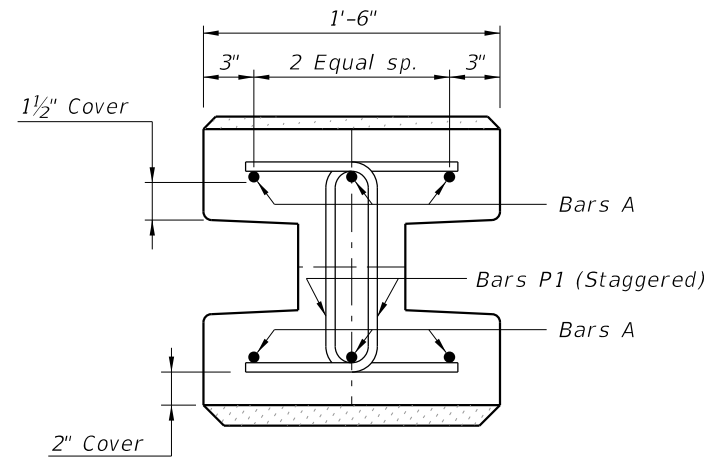

SECTION H-H

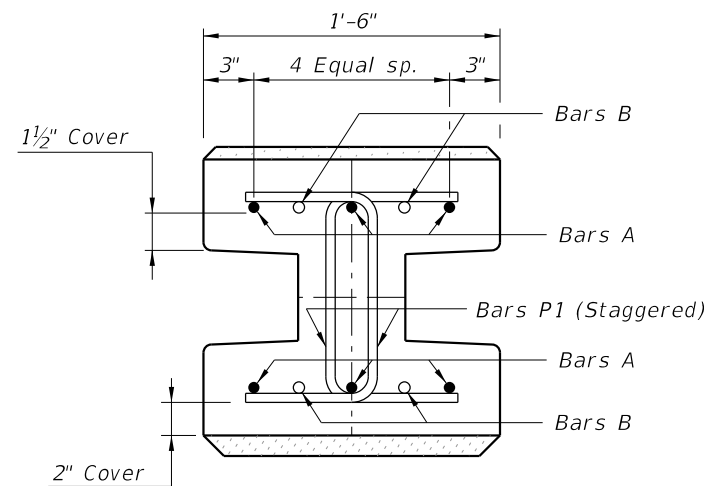

SECTION J-J

NOTES:
1. For Post Reinforcing see Sheets 15 and 16.
2. For Pile Lengths Tables see Sheets 15 and 16.

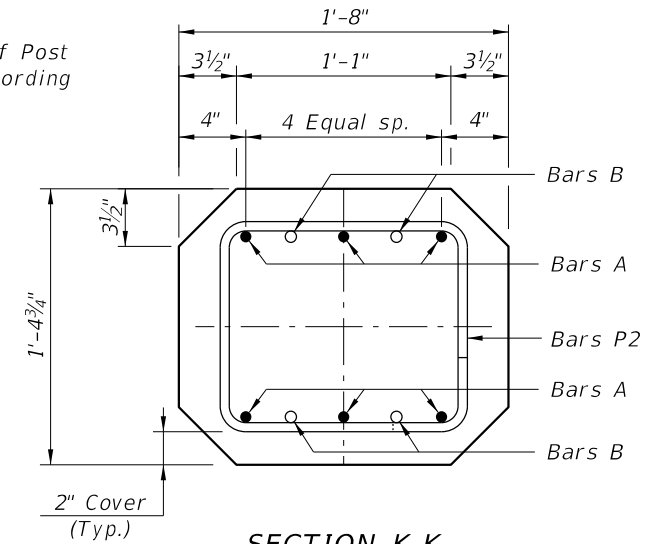

SECTION K-K (Collar Section)

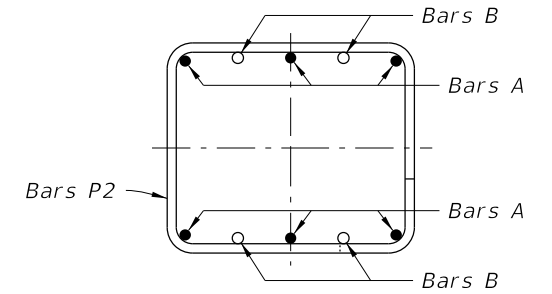

SECTION L-L

STANDARD POST REINFORCEMENT
(Standard Post Shown, 45° Corner Posts Similar)

STANDARD POST DETAILS

LAST REVISION 11/01/16	DESCRIPTION:
---------------------------	--------------



FY 2023-24
STANDARD PLANS

NOISE WALLS - (PRECAST)

INDEX
534-200

SHEET
8 of 16

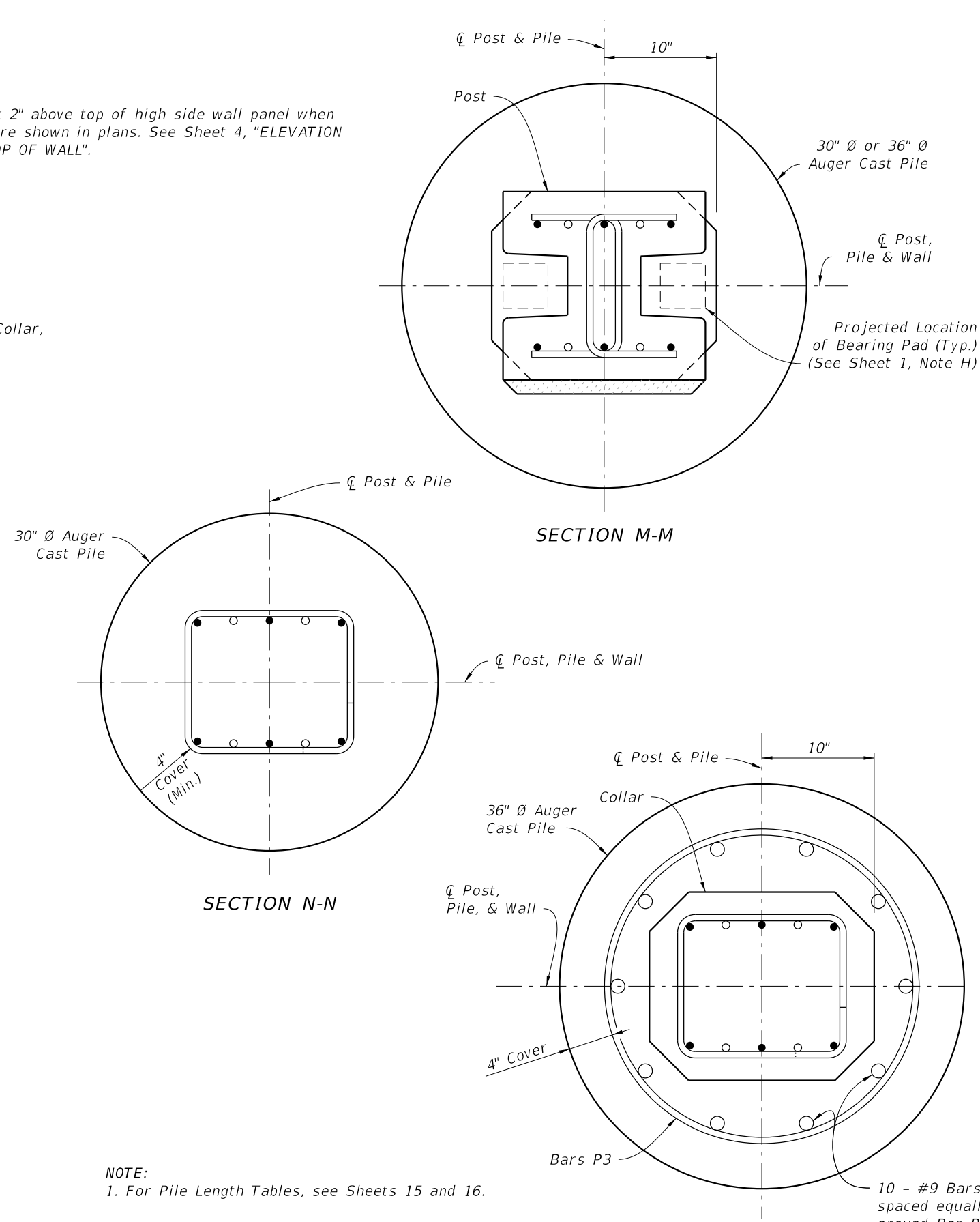
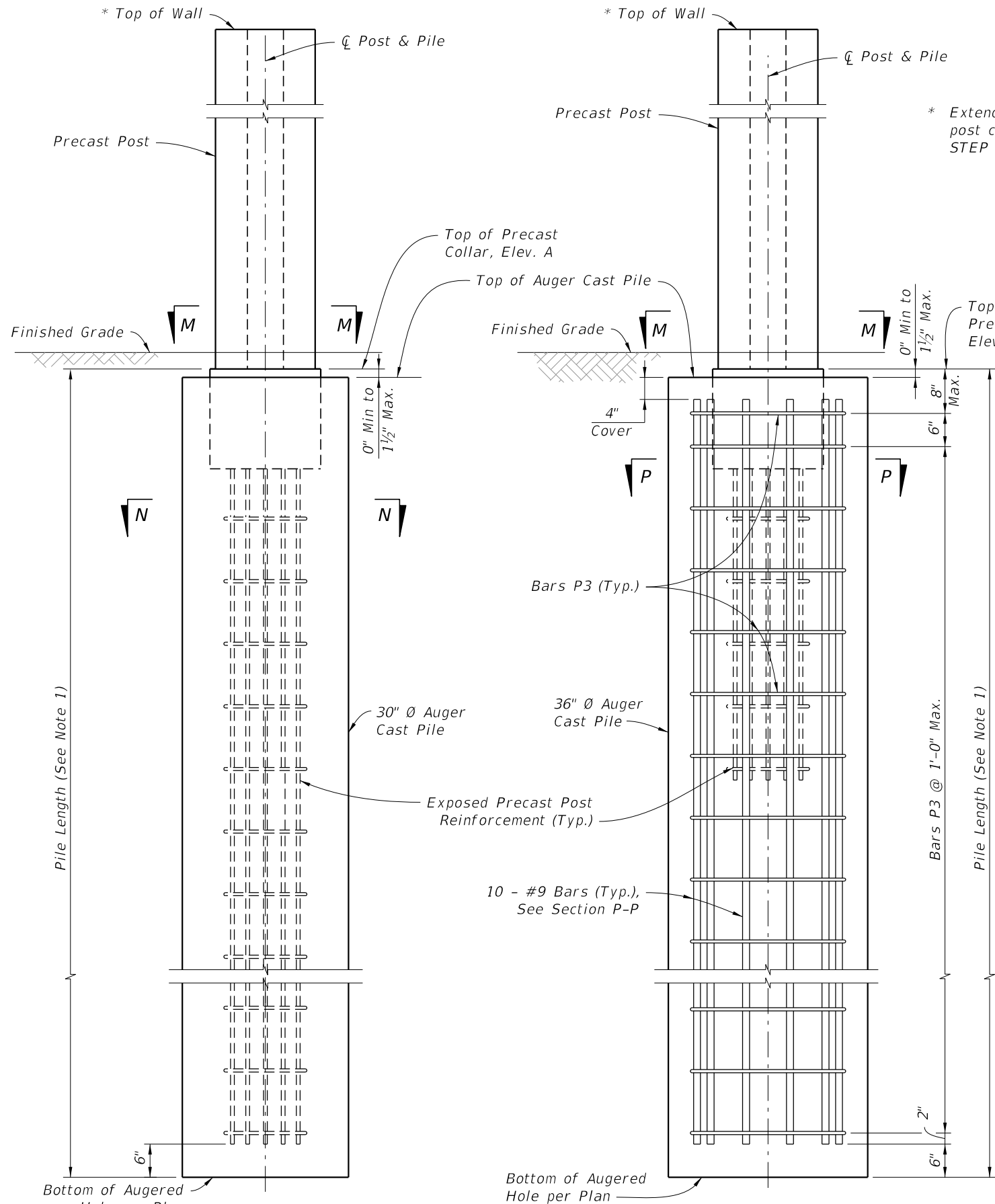

STANDARD POST PLACEMENT IN AUGER CAST PILE
(H-Post Shown, 45° Corner Posts Similar)

POST PLACEMENT & PILE REINFORCING STEEL DETAILS

10/20/2022 8:52:43 AM

LAST REVISION 11/01/16	REVISION	DESCRIPTION:		FY 2023-24 STANDARD PLANS	NOISE WALLS - (PRECAST)	INDEX 534-200	SHEET 9 of 16
---------------------------	----------	--------------	--	------------------------------	-------------------------	------------------	------------------

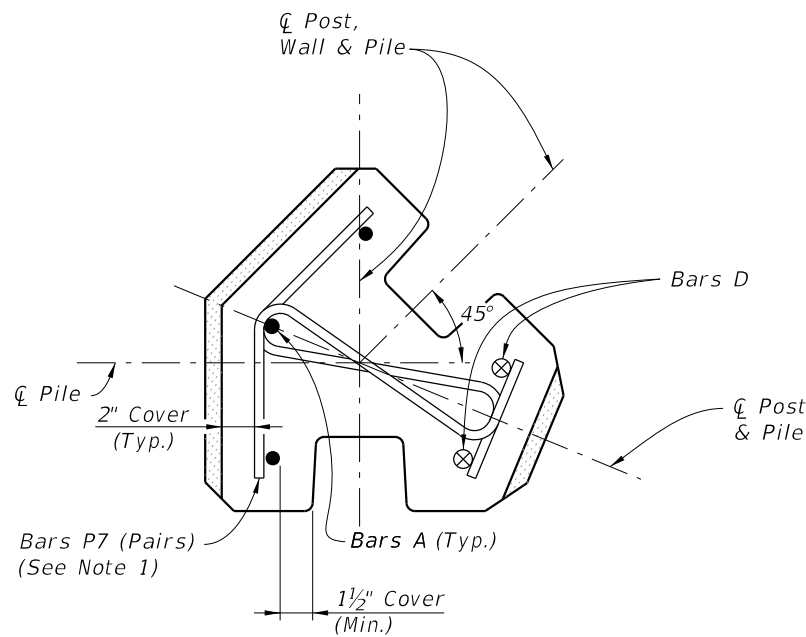

SECTION H-H
(45° Corner Post)

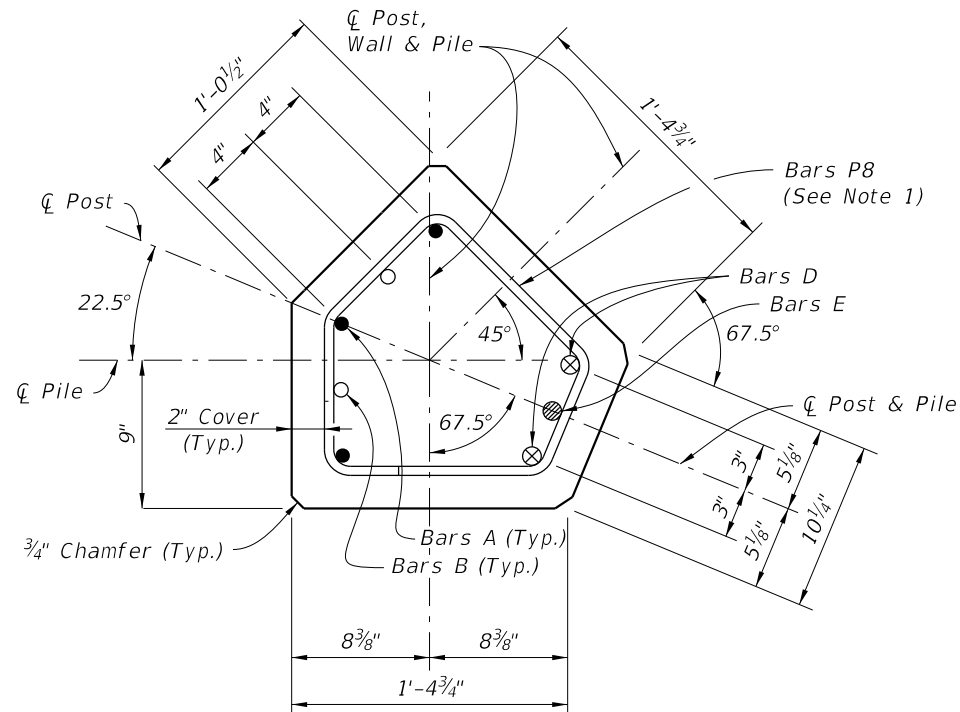

SECTION K-K
(Collar Section, 45° Corner Post)

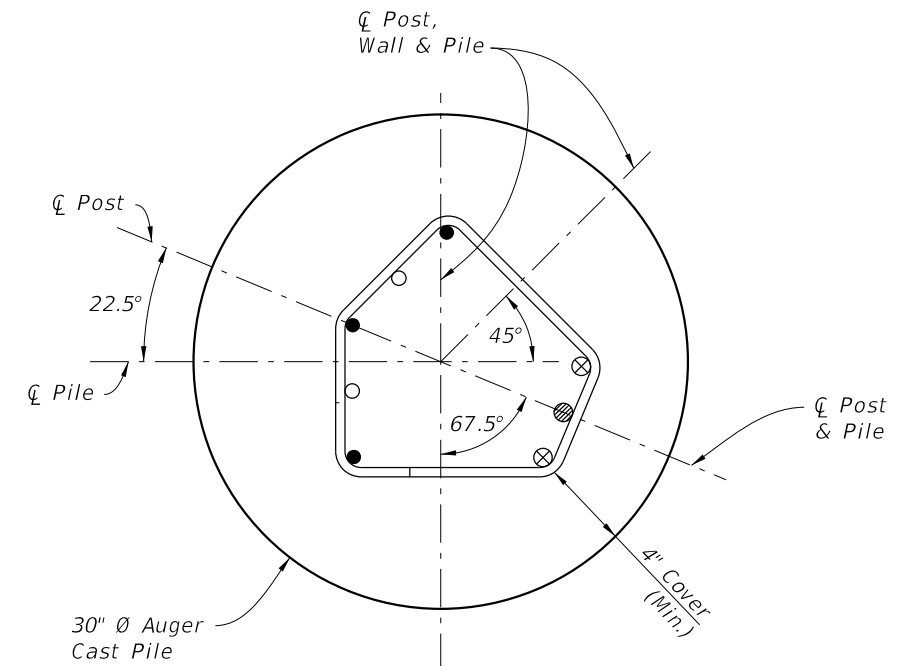

SECTION N-N
(45° Corner Post)

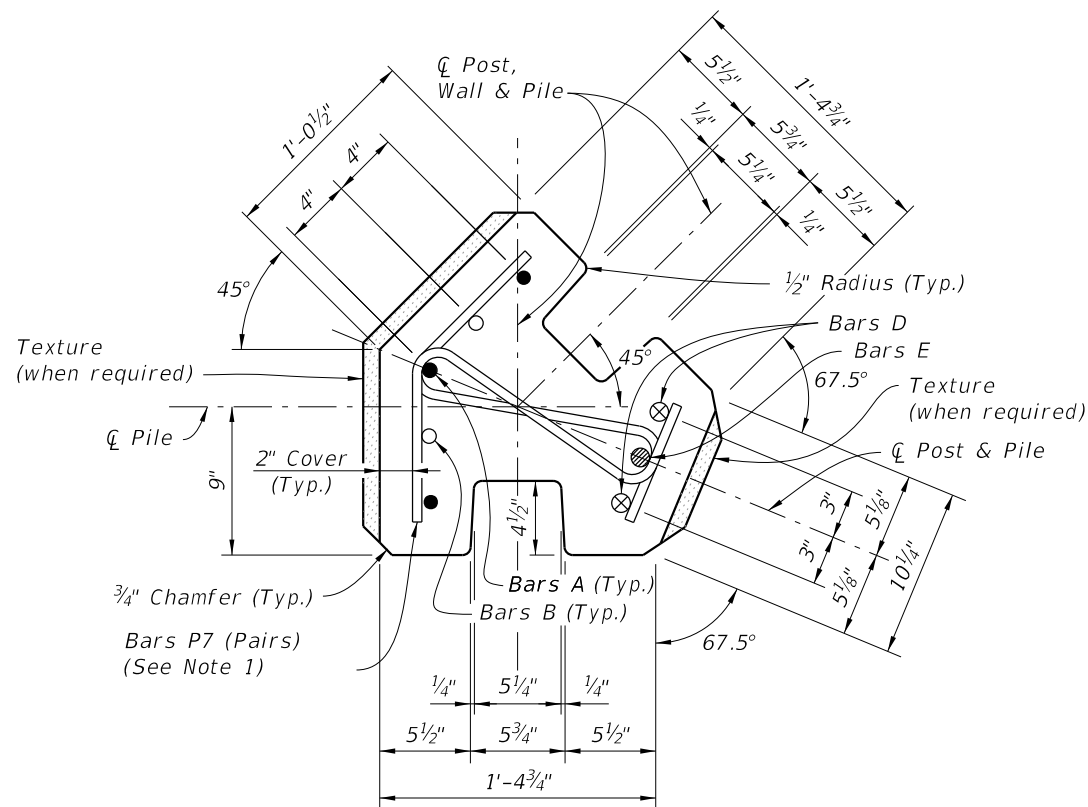

SECTION J-J
(45° Corner Post)

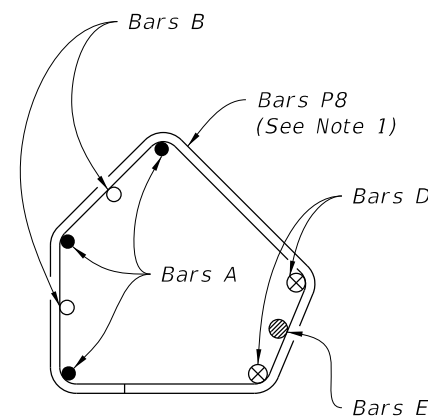

SECTION L-L
(45° Corner Post)

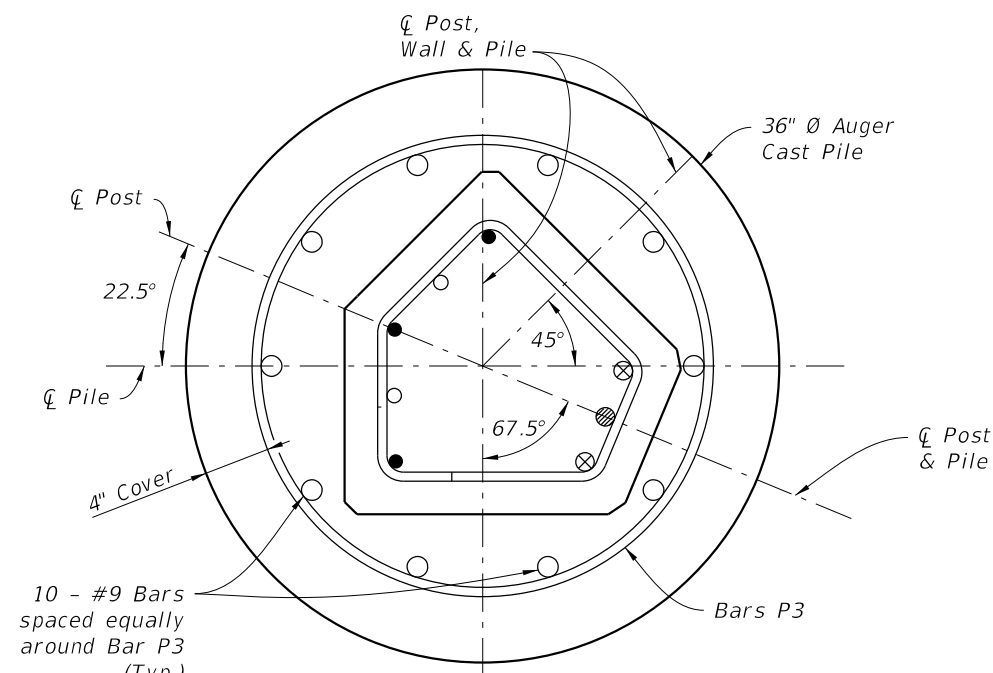

SECTION P-P
(45° Corner Post)

45° POST NOTES:

1. Reference Sheets 8 & 9 for location of Sections.
Space Bars P7 as shown for Bars P1.
Space Bars P8 as shown for Bars P2.
2. Match texture thickness with appropriate Panel face.
3. For Post Reinforcing, see sheets 15 & 16.
4. For Pile Length Tables, see sheets 15 & 16.

45° POST DETAILS

45° POST PLACEMENT IN AUGER CAST PILE

45° CORNER POST DETAILS

10/20/2022 8:52:45 AM

LAST REVISION 11/01/17	DESCRIPTION:
---------------------------	--------------



FY 2023-24
STANDARD PLANS

NOISE WALLS - (PRECAST)

INDEX
534-200

SHEET
10 of 16

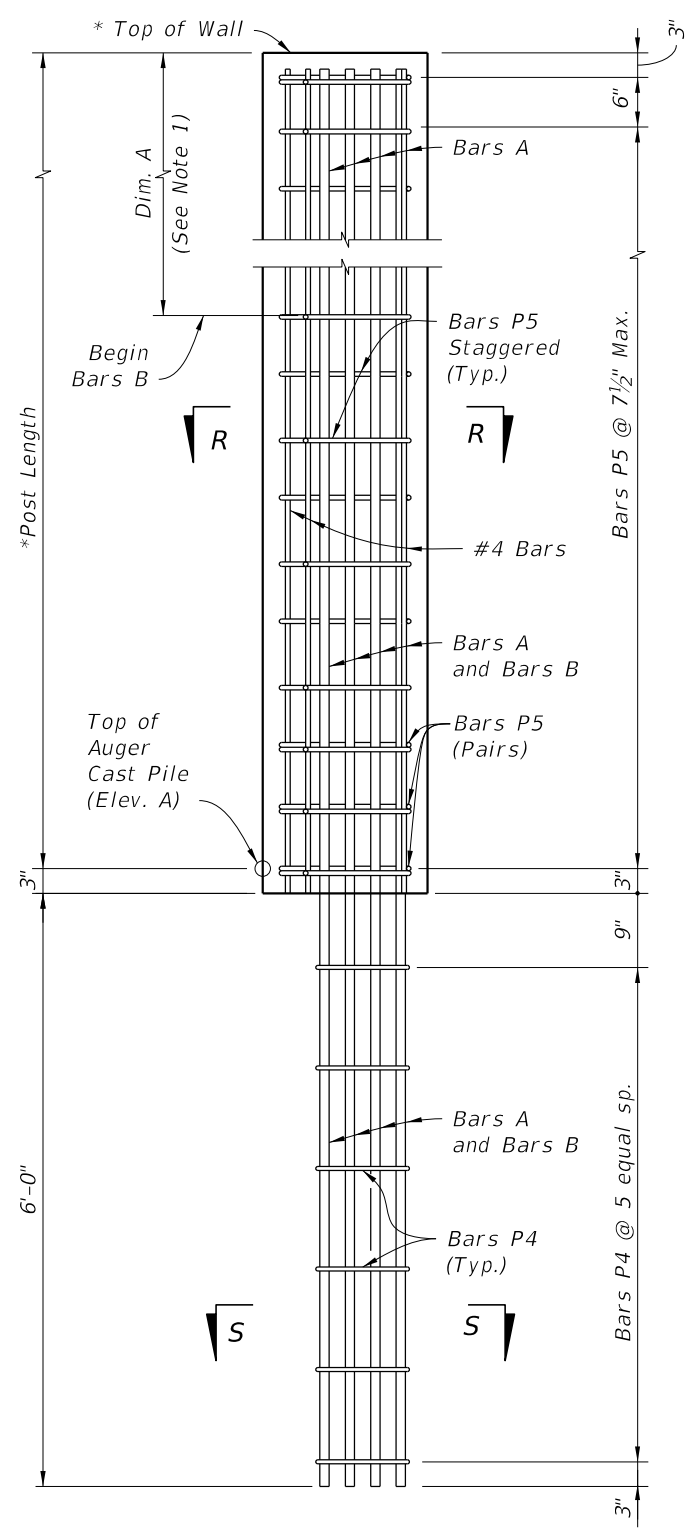
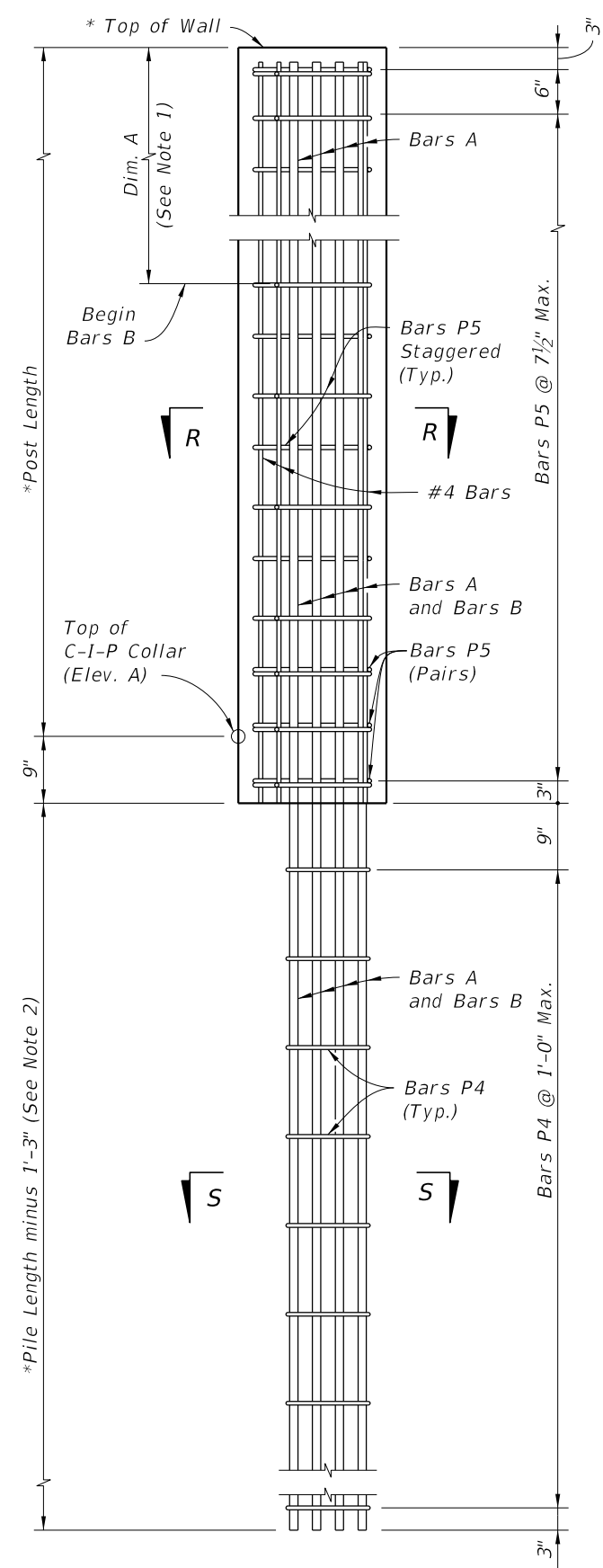

* Extend Post 2" above top of high side wall panel when post caps are shown in plans. See Sheet 4, "ELEVATION STEP AT TOP OF WALL".

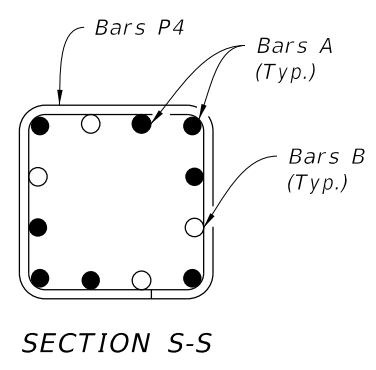
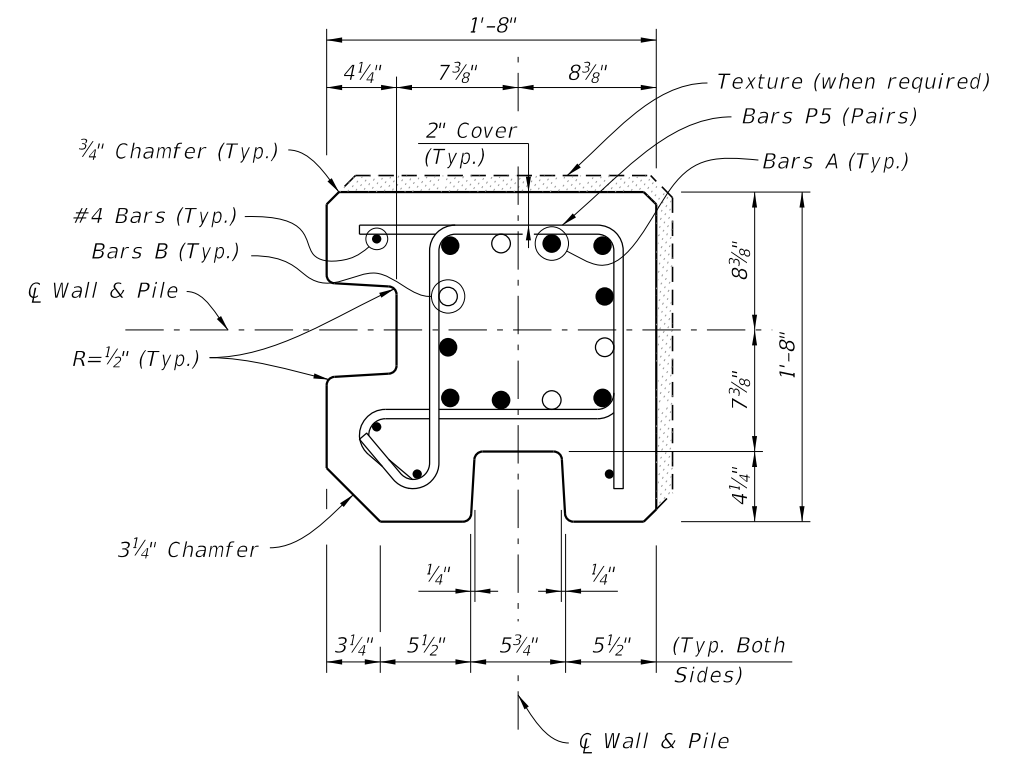

- 90° CORNER POST NOTES:**
1. For Post Reinforcing, see Sheets 15 and 16.
 2. For Pile Length Tables, see Sheets 15 and 16.
 3. Reduce typical panel length or adjust pile spacing at each 90° Corner Post.
 4. Match texture thickness with appropriate Panel face.

TYPICAL POST

LOW CLEARANCE OPTION

SECTION R-R

SECTION S-S

90° CORNER POST REINFORCMENT
(Post Surface Features Not Shown For Clarity)

90° CORNER POST DETAILS

10/20/2022 8:52:46 AM

LAST REVISION 11/01/16	DESCRIPTION:		FY 2023-24 STANDARD PLANS	NOISE WALLS - (PRECAST)	INDEX	SHEET
			534-200		11 of 16	

10/20/2022 8:52:46 AM

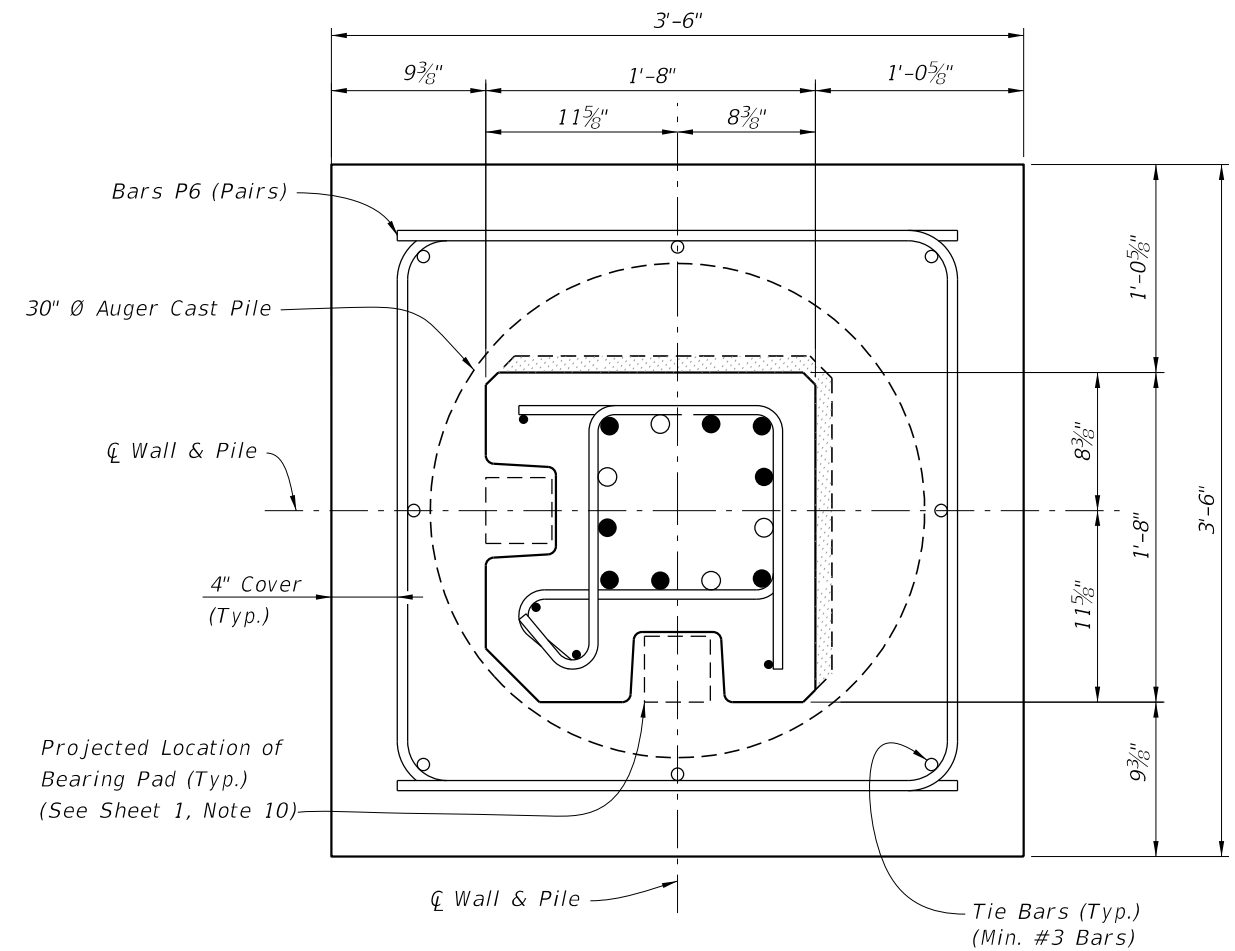
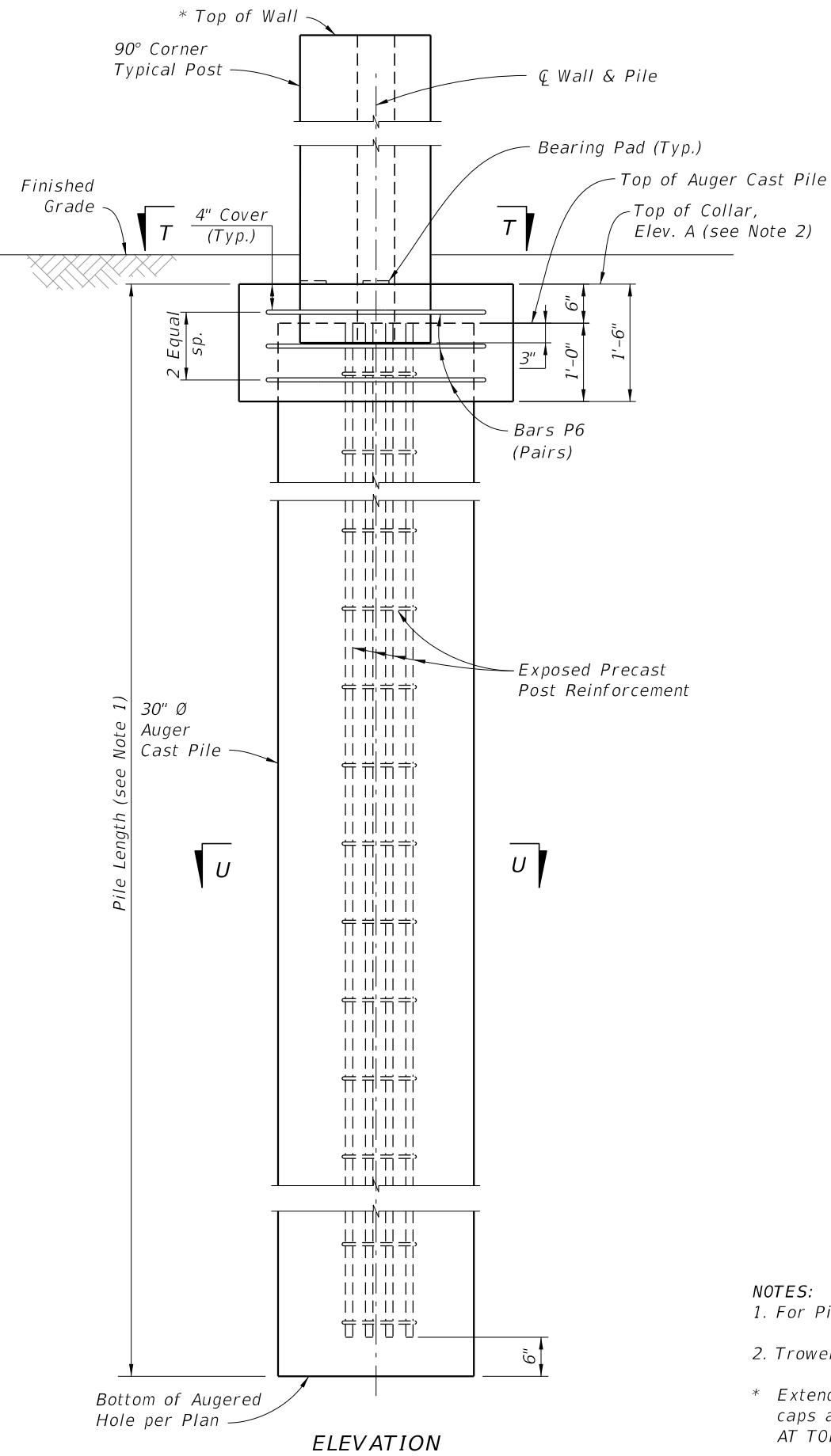

SECTION T-T
C-I-P COLLAR

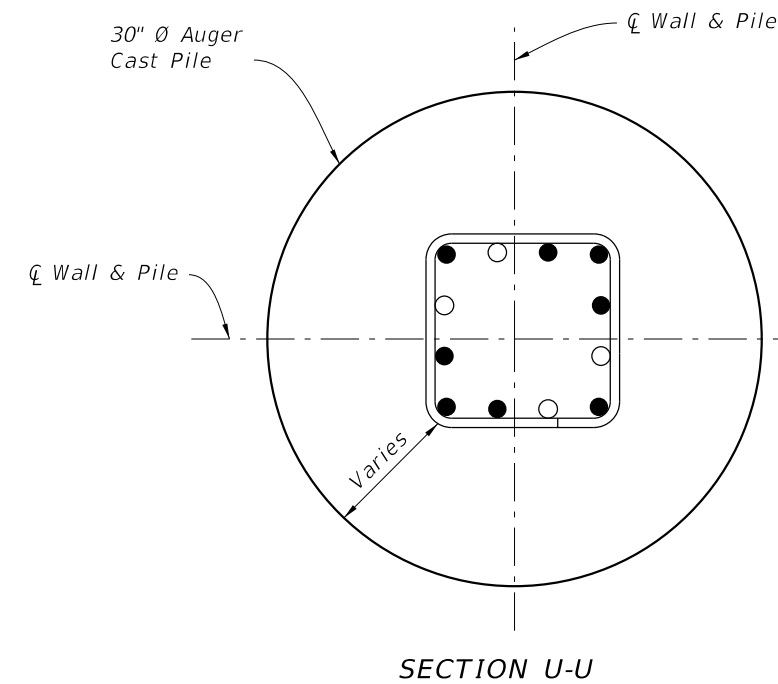

SECTION U-U

NOTES:

1. For Pile Length Tables, see Sheets 15 and 16.
 2. Trowel Finish top of Collar to allow placement of Bearing Pads.
- * Extend Post 2" above top of high side wall panel when post caps are shown in plans. See Sheet 4, "ELEVATION STEP AT TOP OF WALL".

90° CORNER TYPICAL POST PLACEMENT DETAILS

LAST REVISION 11/01/17	DESCRIPTION:
---------------------------	--------------



FY 2023-24
STANDARD PLANS

NOISE WALLS - (PRECAST)

INDEX
534-200

SHEET
12 of 16

10/20/2022 8:52:47 AM

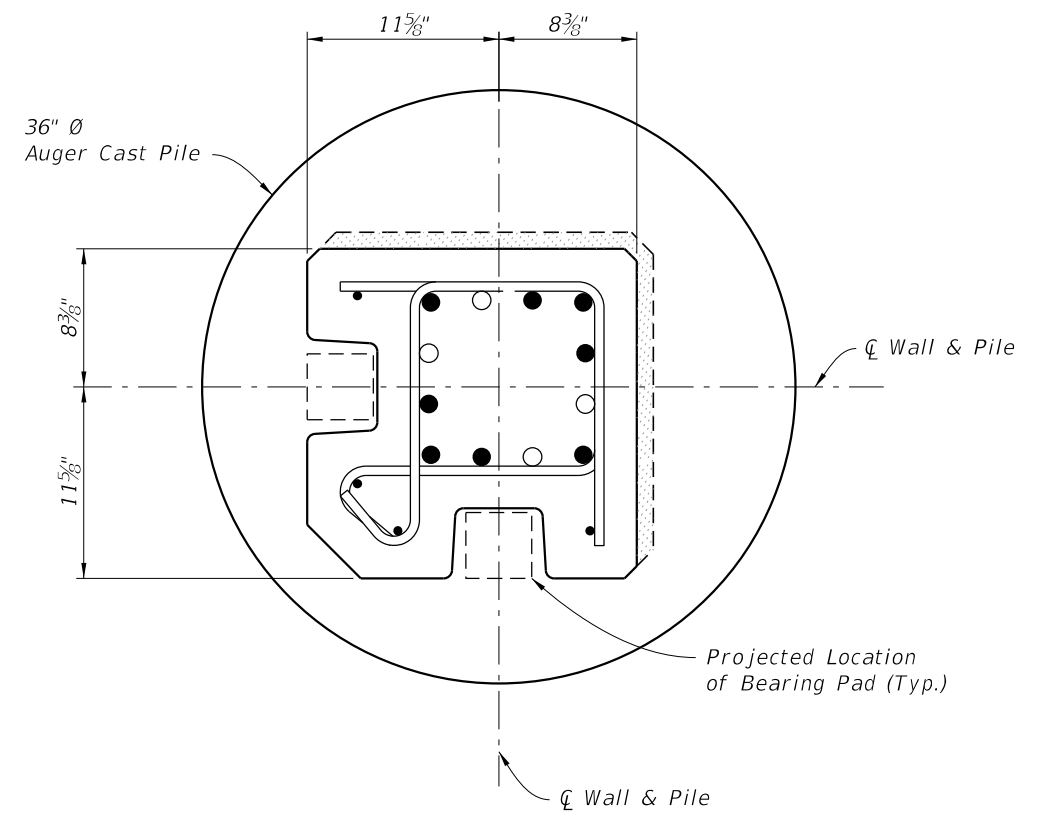
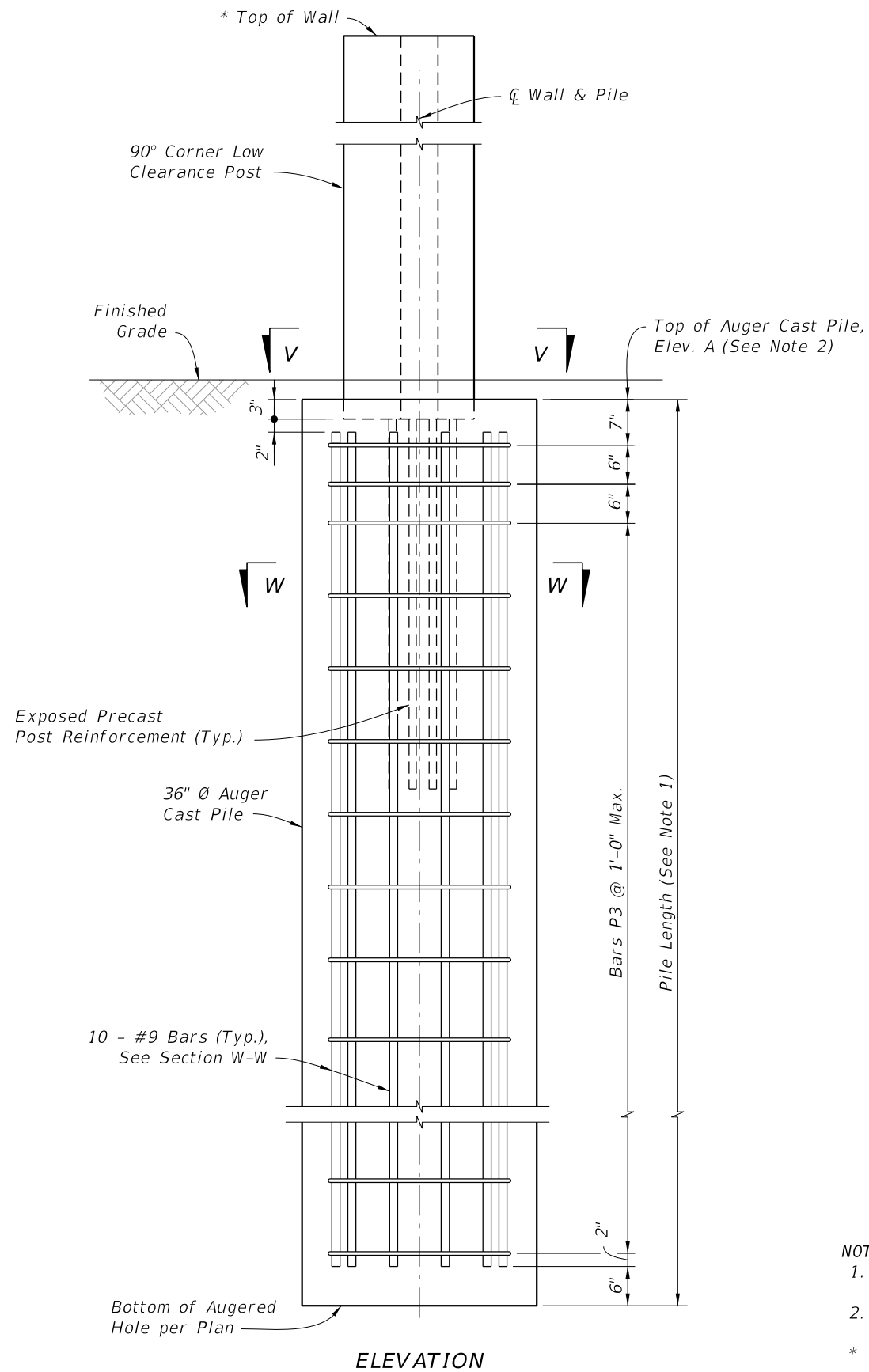

SECTION V-V

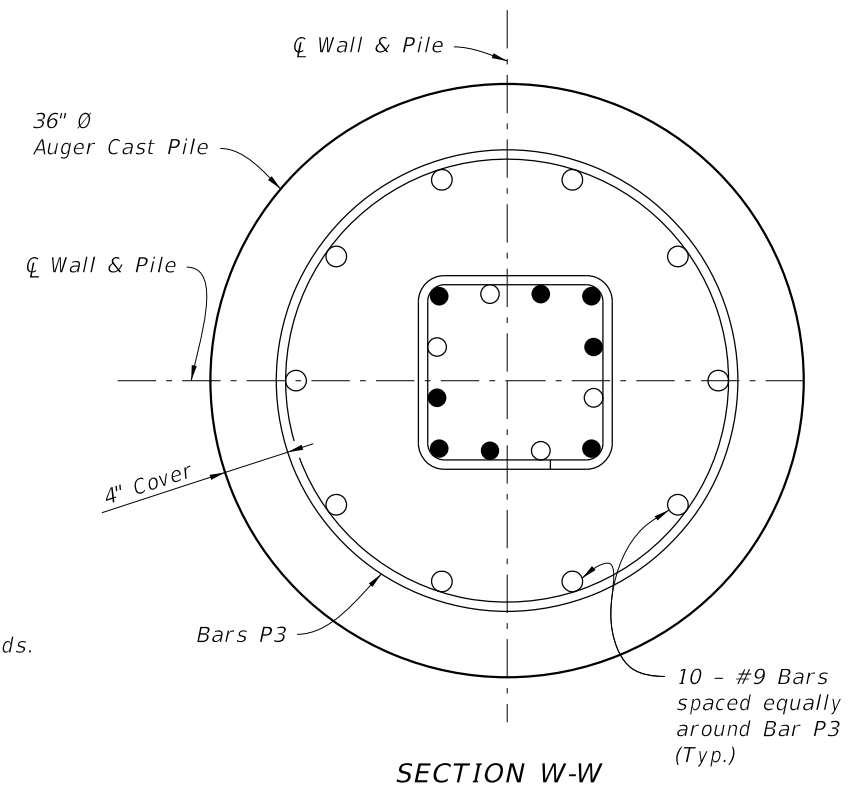

SECTION W-W

NOTES:

1. For Pile Length Tables, see Sheets 15 and 16.
 2. Trowel Finish top of auger cast pile to allow placement of Bearing Pads.
- * Extend Post 2" above top of high side wall panel when post caps are shown in plans. See Sheet 4, "ELEVATION STEP AT TOP OF WALL".

90° CORNER LOW CLEARANCE POST PLACEMENT & PILE REINFORCING STEEL DETAILS

LAST REVISION	DESCRIPTION:
11/01/12	

FY 2023-24
STANDARD PLANS

NOISE WALLS - (PRECAST)

INDEX	SHEET
534-200	13 of 16

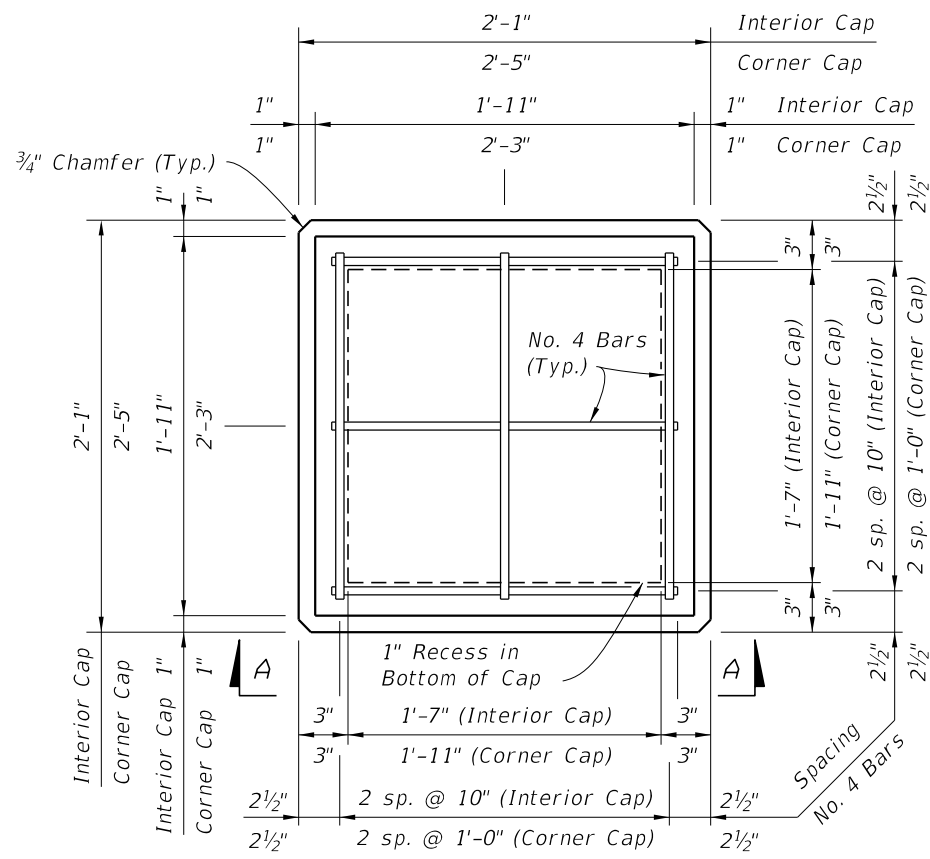

PLAN VIEW

(Type "A" Cap Shown, Type "B" & "C" Caps Similar)

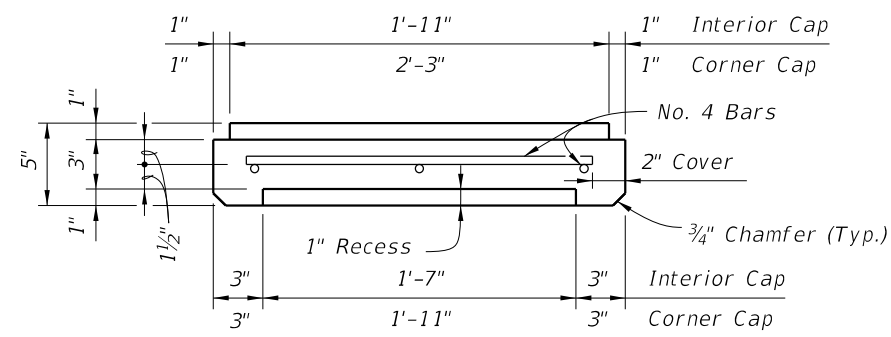

SECTION C-C

TYPE "A" CAP DETAILS

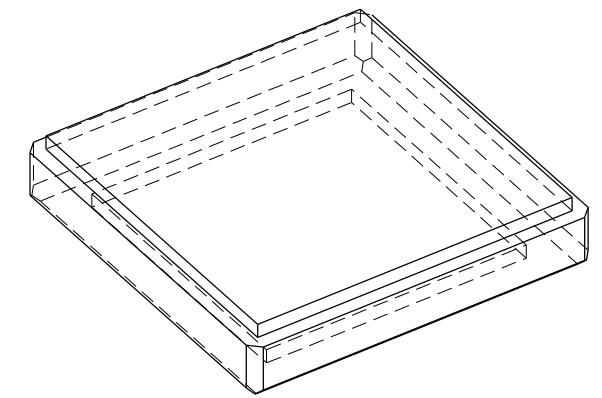

PICTORIAL VIEW

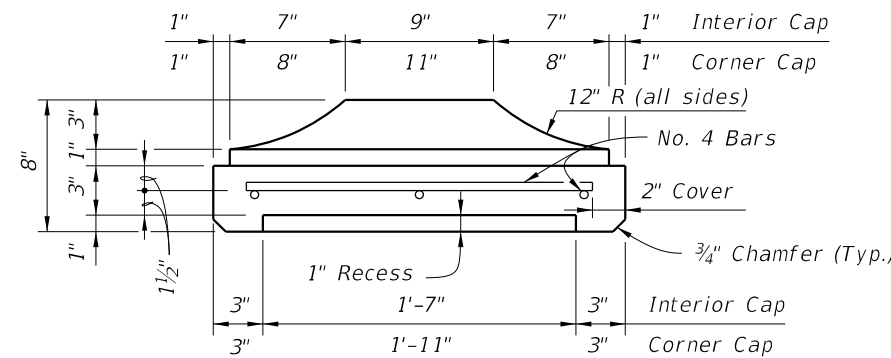

SECTION C-C

TYPE "B" CAP DETAILS

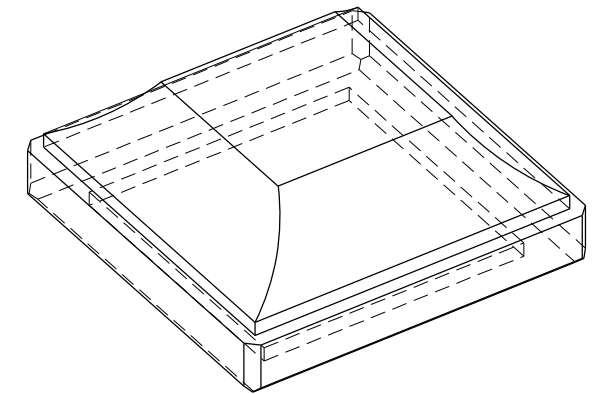

PICTORIAL VIEW

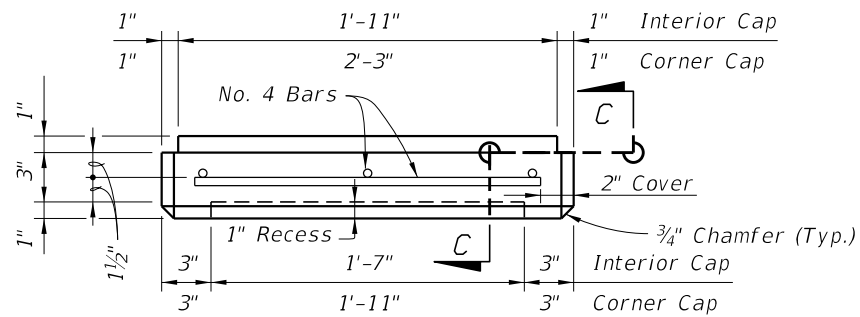

VIEW A-A SHOWN, VIEW B-B SIMILAR

(Type "A" Cap Shown, Type "B" & "C" Caps Similar)

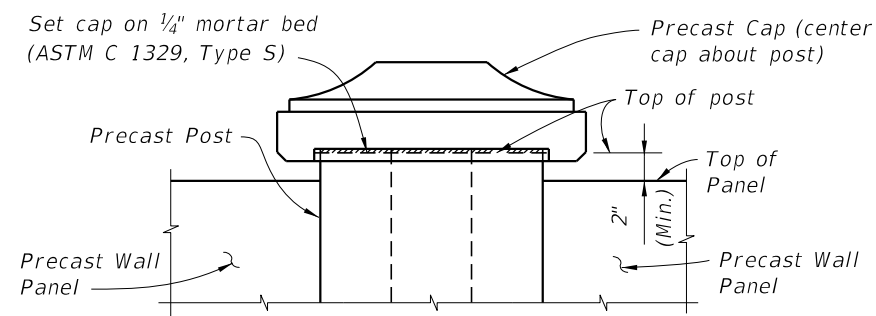

CAP PLACEMENT DETAIL

(Type "B" Cap Shown, Type "A" & "C" Caps Similar)

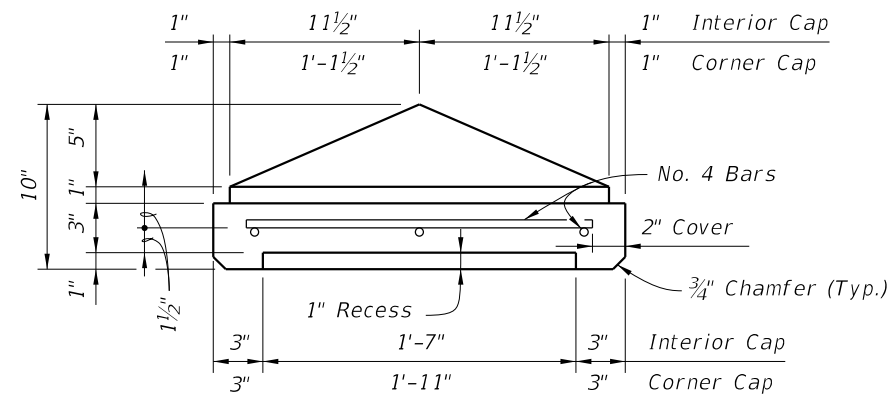

SECTION C-C

TYPE "C" CAP DETAILS

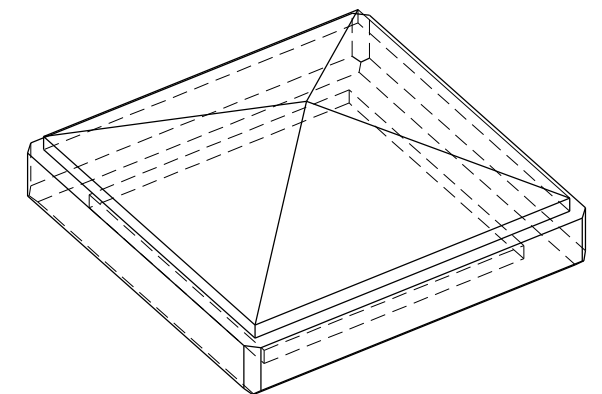

PICTORIAL VIEW

PRECAST POST CAPITAL

10/20/2022 8:52:48 AM

LAST REVISION 11/01/14	DESCRIPTION:
---------------------------	--------------



FY 2023-24
STANDARD PLANS

NOISE WALLS - (PRECAST)

INDEX
534-200

SHEET
14 of 16

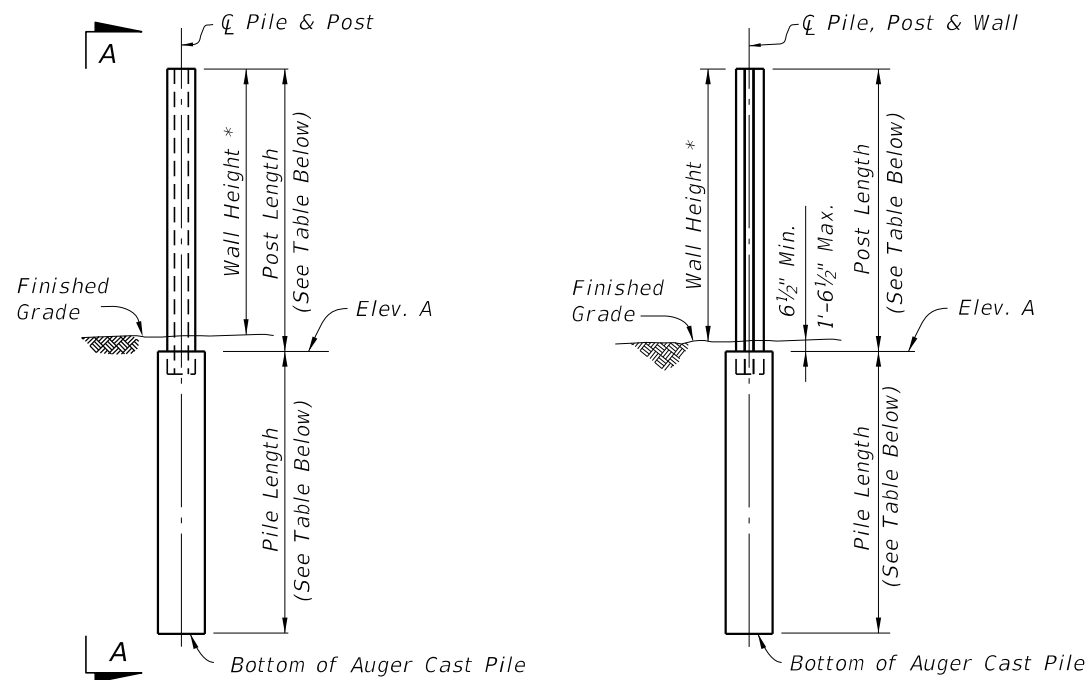

PILE/POST ELEVATION

VIEW A-A

* See Sheet 1, Note 4.

BAR BENDING DETAILS
All bar dimensions in bending diagrams are out-to-out. All bars not shown in the bending diagrams are straight.

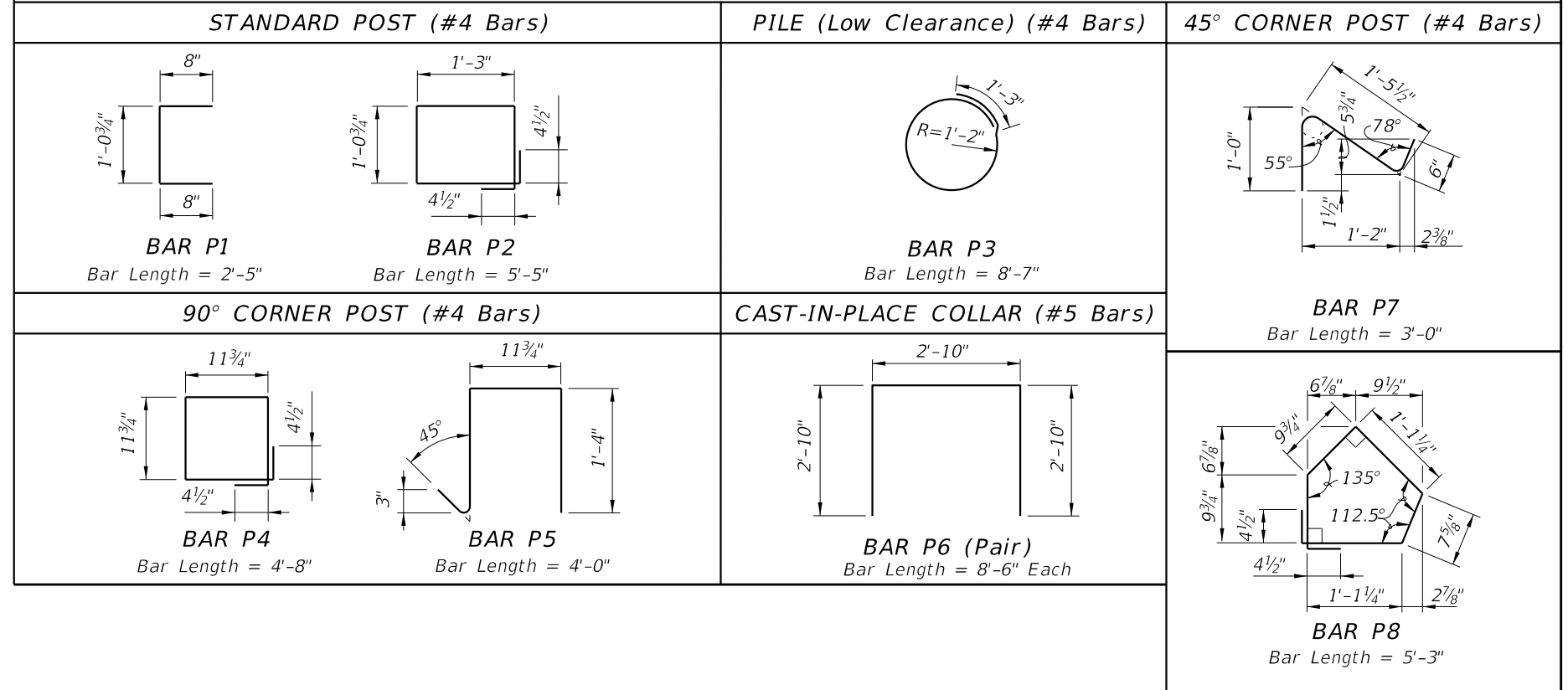

TABLE 1A - TABLE OF POST REINFORCING STEEL															TABLE 1B - PILE LENGTHS (Feet) - WIND SPEED = 130 MPH																
NOMINAL WALL HEIGHT (Feet)	POST LENGTHS		WIND SPEED = 130 MPH												NOMINAL WALL HEIGHT (Feet)	10'-0" POST SPACING								20'-0" POST SPACING							
	WITHOUT CAP	WITH CAP	10'-0" POST SPACING						20'-0" POST SPACING							H-POSTS				CORNER POSTS											
			BARS A		BARS B		BARS D		BARS E		BARS A		BARS B			BARS D		BARS E		SOIL 1		SOIL 2		SOIL 1		SOIL 2					
			SIZE	SIZE	DIM 'A'	SIZE	SIZE	DIM 'A'	SIZE	SIZE	DIM 'A'	SIZE	SIZE	DIM 'A'		SIZE	SIZE	DIM 'A'	SIZE	SIZE	DIM 'A'	SIZE	SIZE	DIM 'A'	SIZE	SIZE	DIM 'A'	SIZE	SIZE	DIM 'A'	
12	13'-0 1/2"	13'-2 1/2"	#4	#4	7'-11"	#4	#4	9'-11"	#5	#5	9'-8"	#6	#6	9'-4"	12	11	10	10	10	11	10	10	10	15	14	13	12	14	13	13	12
13	14'-0 1/2"	14'-2 1/2"	#4	#4	10'-11"	#4	#4	10'-11"	#5	#5	9'-8"	#6	#6	9'-4"	13	12	11	10	10	11	10	10	10	15	14	13	13	15	14	13	12
14	15'-0 1/2"	15'-2 1/2"	#4	#4	10'-11"	#5	#5	11'-8"	#6	#6	11'-4"	#7	#7	10'-8"	14	12	11	11	10	12	11	10	10	16	15	14	13	15	14	14	13
15	16'-0 1/2"	16'-2 1/2"	#4	#4	10'-11"	#5	#5	12'-8"	#6	#6	11'-4"	#7	#7	10'-8"	15	12	12	11	10	12	11	11	10	16	15	15	13	16	15	14	13
16	17'-0 1/2"	17'-2 1/2"	#5	#5	13'-8"	#5	#5	12'-8"	#6	#6	11'-4"	#7	#7	10'-8"	16	13	12	11	11	12	12	11	10	17	16	15	14	16	15	15	14
17	18'-0 1/2"	18'-2 1/2"	#5	#5	14'-8"	#5	#5	12'-8"	#7	#7	12'-8"	#7	#8	10'-0"	17	13	12	12	11	13	12	11	11	18	16	16	14	17	16	15	14
18	19'-0 1/2"	19'-2 1/2"	#5	#5	14'-8"	#6	#6	14'-4"	#7	#7	12'-8"	#8	#8	12'-0"	18	14	13	12	11	13	12	12	11	18	17	16	15	18	16	15	14
19	20'-0 1/2"	20'-2 1/2"	#5	#5	14'-8"	#6	#6	14'-4"	#7	#8	12'-0"	#8	#9	11'-3"	19	14	13	12	12	14	13	12	11	19	17	16	15	18	17	16	15
20	21'-0 1/2"	21'-2 1/2"	#6	#6	16'-4"	#6	#6	14'-4"	#8	#7	14'-8"	#9	#8	14'-0"	20	14	13	13	12	14	13	12	12	19	18	17	16	19	17	16	15
21	22'-0 1/2"	22'-2 1/2"	#6	#6	16'-4"	#6	#6	14'-4"	#8	#8	14'-0"	#9	#10	12'-4"	21	15	14	13	12	14	13	13	12	20	18	17	16	19	18	17	16
22	23'-0 1/2"	23'-2 1/2"	#6	#6	16'-4"	#7	#7	16'-8"	#8	#9	13'-3"	#10	#9	15'-3"	22	15	14	14	13	15	14	13	12	20	19	18	17	20	18	17	16

TABLE NOTE:
 1. Bars D and Bars E are for 45° Corner Posts only.
 2. See Contract Plans for project wind speed.
 3. Soil 1 = Loose Granular Soil, N = 4 to 9.
 Soil 2 = Medium Dense Granular Soil, N = 10 to 40.

PILE DEPTH & REINFORCING SUMMARY

LAST REVISION 11/01/16	DESCRIPTION:		FY 2023-24 STANDARD PLANS	NOISE WALLS - (PRECAST)	INDEX 534-200	SHEET 15 of 16
---------------------------	--------------	--	------------------------------	-------------------------	------------------	-------------------

GENERAL NOTES:

1. Construct Perimeter Walls in accordance with Specification Section 534.
2. Choice of either Precast Option or Masonry Option is at the discretion of the Contractor. Contractor must also select the desired foundation type. Modifications to this Index is restricted to those required for geometric needs only.
3. Post spacing is measured from centerline to centerline of foundation element. For this Index, posts and foundation elements have been designed for 20 ft. spacings. Use post spacings less than 20 feet only at changes in horizontal alignment, wall terminations or to accommodate steep grades.
4. See "Perimeter Wall Data Tables" in the plans for project requirements.
5. Field verify the locations of all overhead and underground utilities shown in the Wall Control Drawings.

PRECAST OPTION NOTES:

6. WALL NOTES:
 - A. Walls may consist of either a single height panel or two stacked panels. Minimum panel height is 4'-3".
 - B. Only when reduced overhead clearance between posts prohibits installation of panels from the top, side-installed panels are allowed. After panel is centered between posts, grout between panel ends and posts.
7. CONCRETE AND GROUT:
 - A. Cast-in-Place and Precast Concrete: Class IV
 - B. Grout for Auger Cast Piling: Minimum 28 Day Strength = 5000 psi
 - C. Minimum Compressive Strength for Form Removal and Handling of Posts, Panels and Precast Spread Footings:
 - i. 2,500 psi for horizontally cast post, panels and precast spread footings.
 - ii. 2,000 psi for vertically cast panels or when tilt-up form tables are used for horizontally cast panels.
8. REINFORCING STEEL:
 - A. Concrete Cover: 1 1/2" unless otherwise noted.
 - B. In addition to the requirements of Specification Section 415, tie post and pile stirrups at the following locations as a minimum:
 - i. Post Stirrups - Tie at all four corner bars and at every third interior bar intersection.
 - ii. Pile Stirrups - Tie to the main vertical reinforcing at alternate intersections.
9. BEARING PADS:
 - A. Bearing Pads for Collar or Pedestal Bearing Points and between stacked panels may be either Plain or Fiber Reinforced Neoprene Pads, in accordance with Specification Section 932 for ancillary structures.
10. CASTING TOLERANCES:
 - A. Overall Height & Width: +/- 1/4"
 - B. Thickness: +/- 1/4"
 - C. Plane of side mold: +/- 1/16"
 - D. Openings: +/- 1/2"
 - E. Out of Square: 1/8" per 6 ft., but not more than 3/8" total along any side
 - F. Warping: 1/16" per foot distance to nearest corner
 - G. Bowing: 1/240 panel dimension
11. PILING:
 - A. Construct Auger Cast Piling in accordance with the Plans and Specification Section 455.

MASONRY OPTION NOTES:

12. WALL NOTES:
 - A. Inspect construction in accordance with the International Building Code (IBC) Section 17.
 - B. Construct masonry walls with 8x8x16 block using a running bond pattern and concave tooled joints.
 - C. Make all elevation changes (steps) in footing and top of wall using full height blocks. Make top of wall steps at pilasters exclusively. Footing steps may be made between pilasters as necessary to maintain minimum soil cover.

MASONRY OPTION NOTES (CONT.):

- D. Fully Grout all cells with horizontal or vertical reinforcing bars.
 - E. Use reinforcing bar positioners to maintain vertical and horizontal bar placement.
 - F. Fully grout first three courses of the wall.
 - G. Joint Reinforcement: Use W 1.7 (9mm) galvanized ladder reinforcing spaced at 16" vertically. Provide special accessories for corners, intersections, etc. Joint reinforcing shall be continuous except it shall not pass through vertical masonry control joints. Lap joint reinforcing a minimum of 6".
 - H. Construct expansion joints in the foundation at 90 foot maximum intervals, and directly below a wall control joint.
 - I. Dowel Load Transfer Devices will be ASTM A 36 smooth round bars hot-dip galvanized in accordance with Specification Section 962. Install Dowel Load Transfer Devices in accordance with Specification Section 350.
 - J. For spread footings, use a walk-behind compactor of at least 600 lbs. in weight. Obtain a minimum density of 95% of the maximum dry density as determined by FM 1 T-180. Perform soil density tests at 100 foot intervals.
 - K. Protect walls during construction from soil, grout or mortar stains. Clean wall as work progresses by dry brushing to remove mortar fins and smears before tooling joints.
 - L. Use soap and potable water to clean walls. If stain removal is necessary, use a cleaning method indicated in NCMA TEK 8-2A applicable to the type of stain on the exposed surface.
 - M. During construction, cover tops of walls, with waterproof sheeting at the end of each day's work, or when construction is not in progress. Extend sheeting a minimum of 2 feet down each side and secure in place.
 - N. Comply with Hot Weather Requirements in ACI 530.1.
13. MATERIALS:
 - A. Concrete Masonry Units (CMU): Provide normal weight blocks.
 - B. Cast-In-Place Concrete: Class II for slightly to moderate aggressive environments or Class IV for extremely aggressive environments.
 - C. Mortar: Type S meeting requirements of ASTM C1329
 - D. Grout: Type S; coarse grout.
 - E. Aggregate for Grout: Meet the requirements of ASTM C404 or Specification Section 901 size 8 or 89.
 14. STORAGE OF MATERIALS:
 - A. Store CMU's on elevated platforms in a dry location or under cover. If units become wet, do not install until they are dry.
 - B. Store cementitious materials on elevated platforms, under cover, and in a dry location. Do not use cementitious materials that have become damp or exceeded the manufacturers shelf life.
 - C. Store masonry accessories and reinforcing to prevent corrosion and accumulation of dirt and oil.

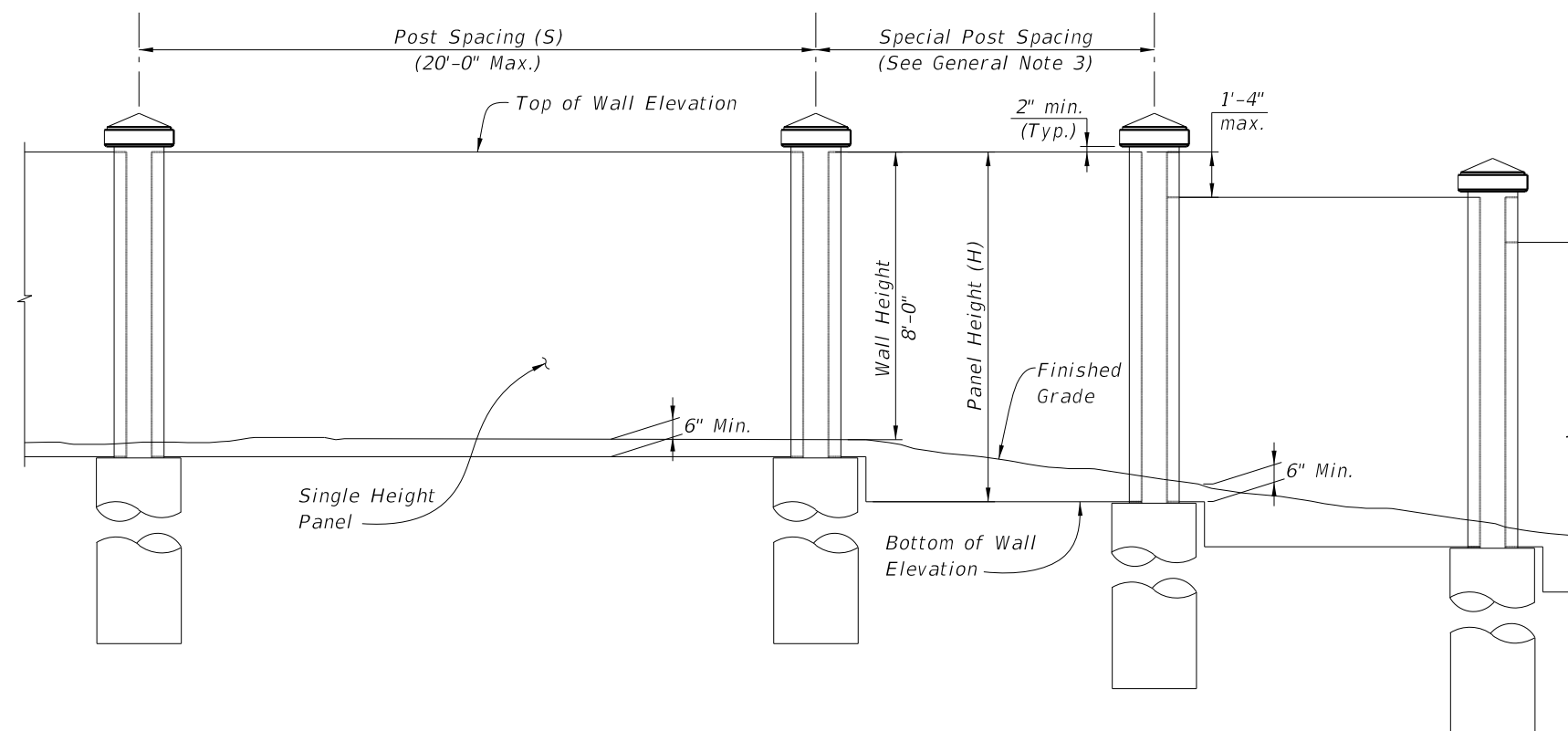

GENERAL WALL ELEVATION
(Precast Option with Single Height Panel Shown, Others Similar)

GENERAL NOTES

10/20/2022 8:52:50 AM

LAST REVISION 11/01/17	DESCRIPTION:	 FY 2023-24 STANDARD PLANS	PERIMETER WALLS	INDEX 534-250	SHEET 1 of 10
---------------------------	--------------	---	------------------------	-------------------------	-------------------------

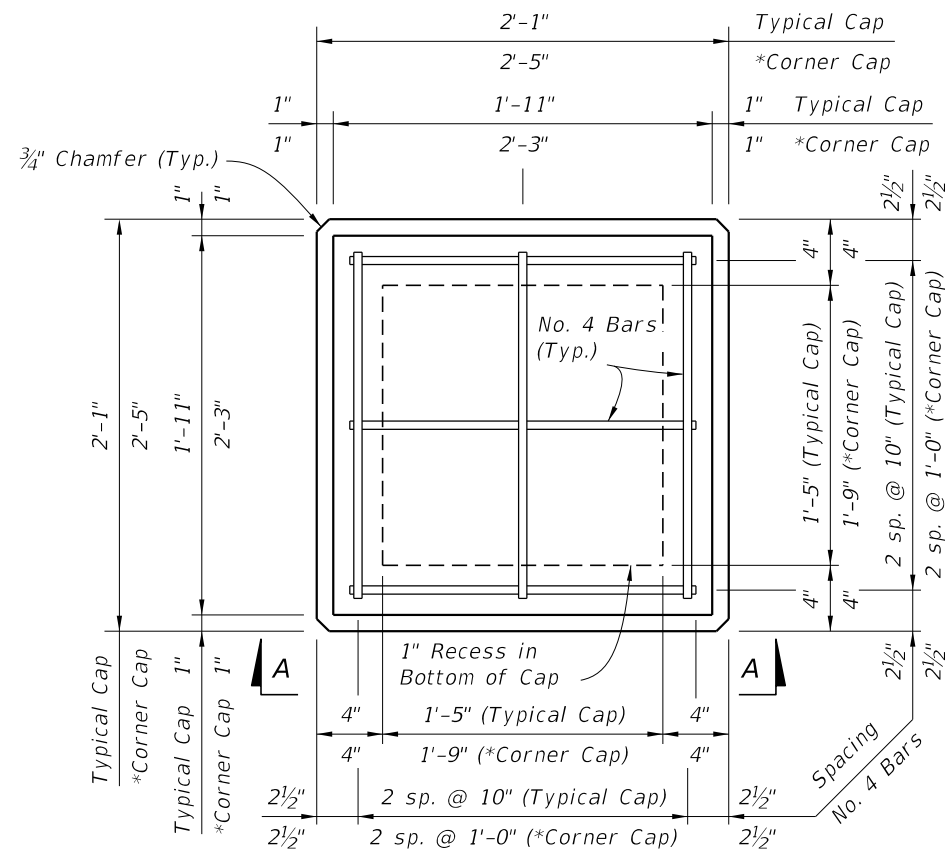

PLAN VIEW

(Type "A" Cap Shown, Type "B" & "C" Caps Similar)

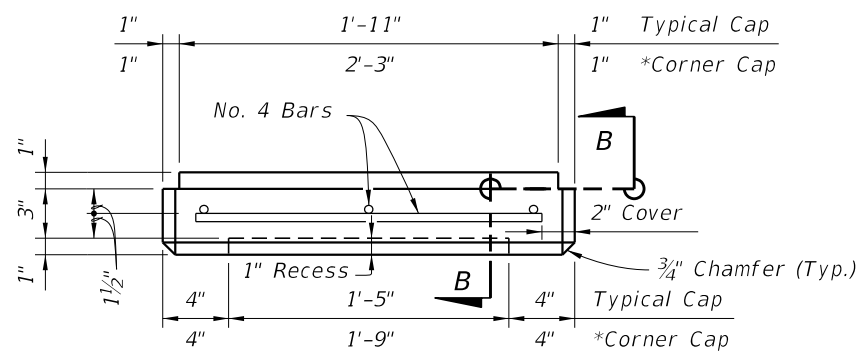

VIEW A-A

(Type "A" Cap Shown, Type "B" & "C" Caps Similar)

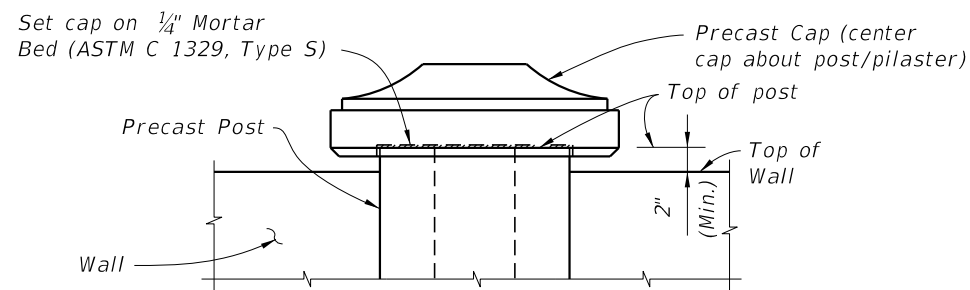

CAP PLACEMENT DETAIL

(Type "B" Post Cap with Precast Option Shown)

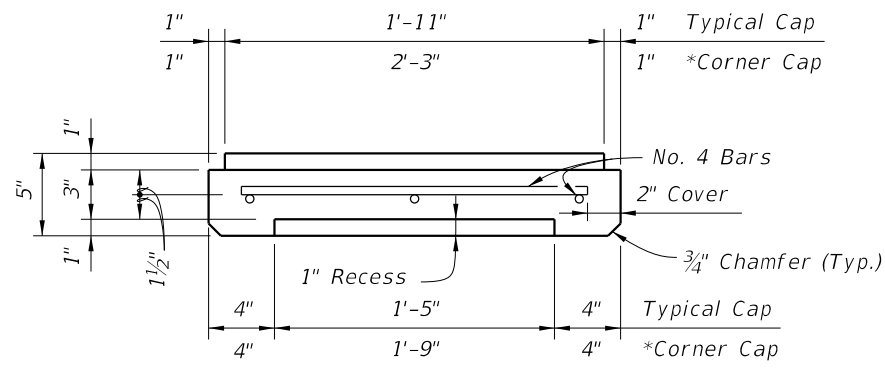

SECTION B-B

TYPE "A" CAP DETAILS

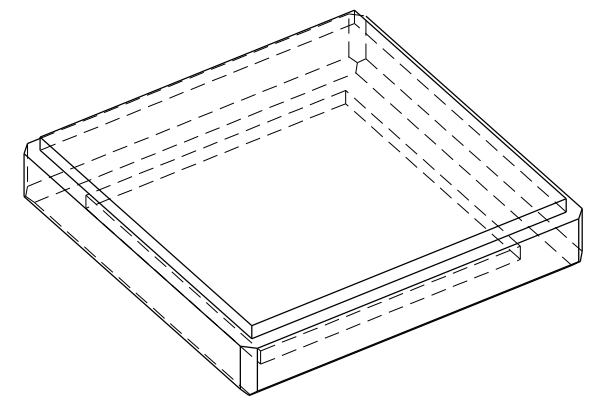

PICTORIAL VIEW

*Precast Option only

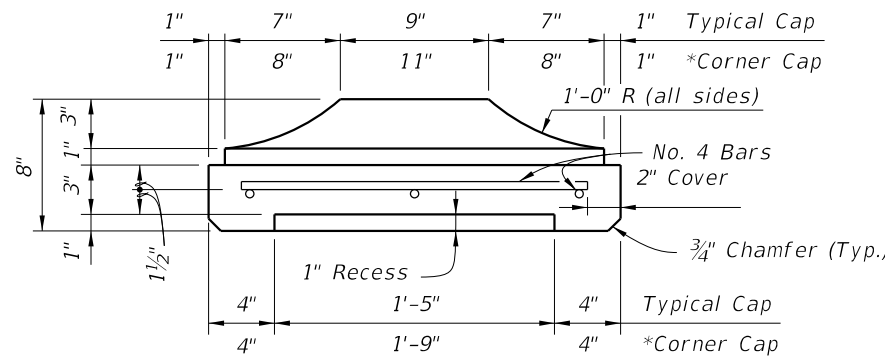

SECTION B-B

TYPE "B" CAP DETAILS

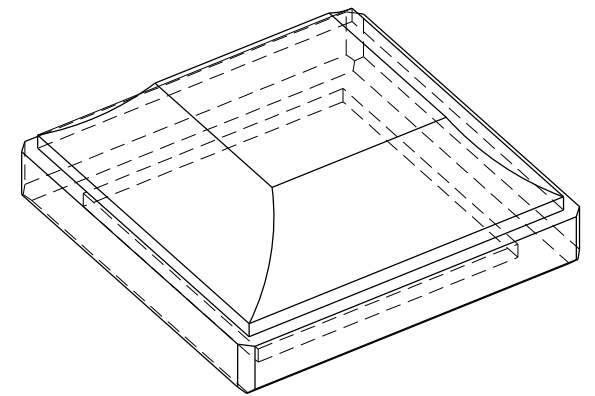

PICTORIAL VIEW

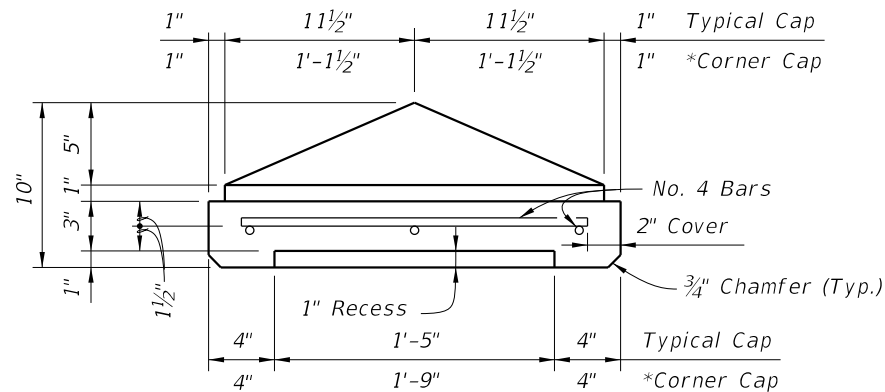

SECTION B-B

TYPE "C" CAP DETAILS

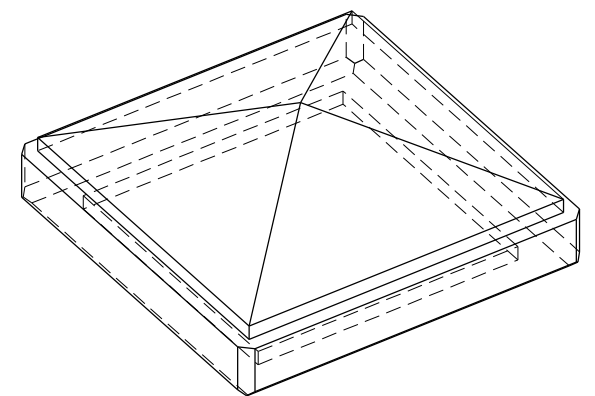

PICTORIAL VIEW

POST CAP DETAILS

10/20/2022 8:52:52 AM

LAST REVISION 11/01/14	DESCRIPTION:
---------------------------	--------------



FY 2023-24
STANDARD PLANS

PERIMETER WALLS

INDEX
534-250

SHEET
2 of 10

10/20/2022 8:52:52 AM

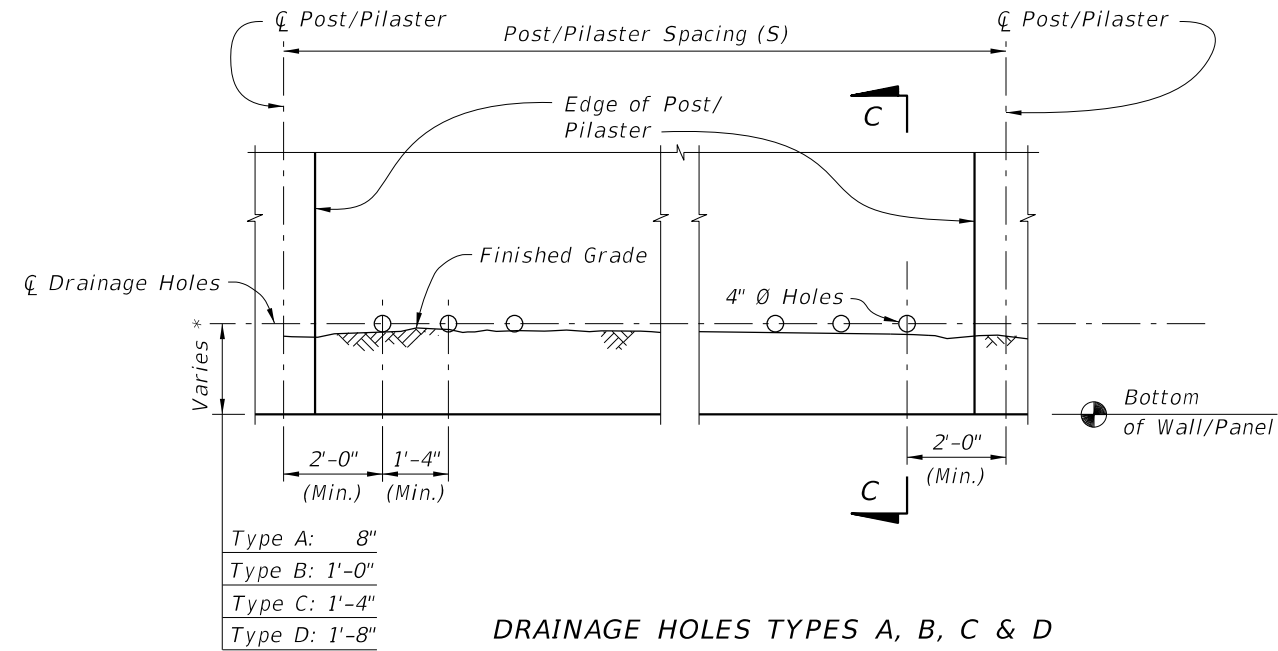

DRAINAGE HOLES TYPES A, B, C & D

* Hole Types A, B, C, & D refer to distance from bottom of panel/wall to center of the pipe.

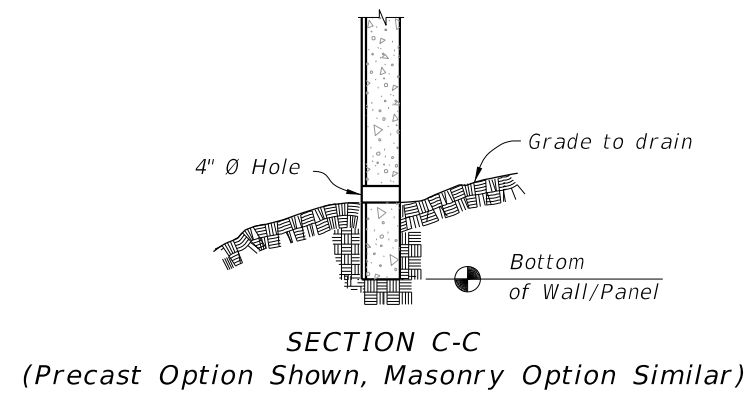

NOTES:

1. Drainage holes may be formed with 4" NPS PVC pipe that may remain in place.
2. See Wall Control drawings for number, Type and location/spacing of drainage holes.

DRAINAGE DETAILS

LAST REVISION 11/01/14	DESCRIPTION:
---------------------------	--------------



FY 2023-24
STANDARD PLANS

PERIMETER WALLS

INDEX
534-250

SHEET
3 of 10

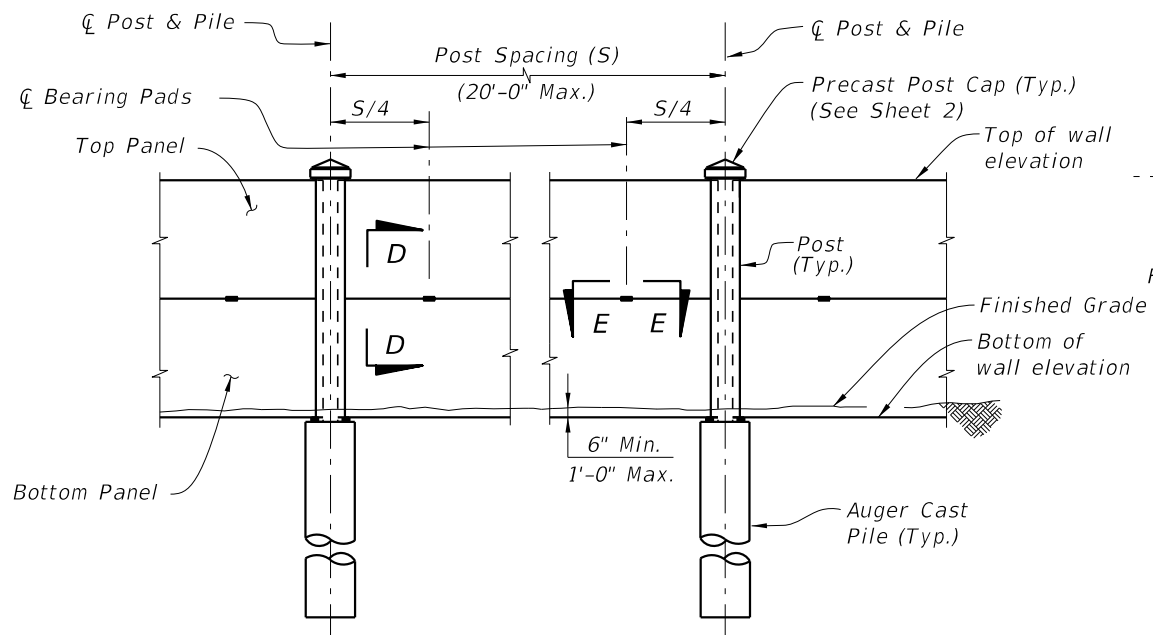

TYPICAL ELEVATION
(Front Face Shown, Textured Finish not Shown for Clarity)

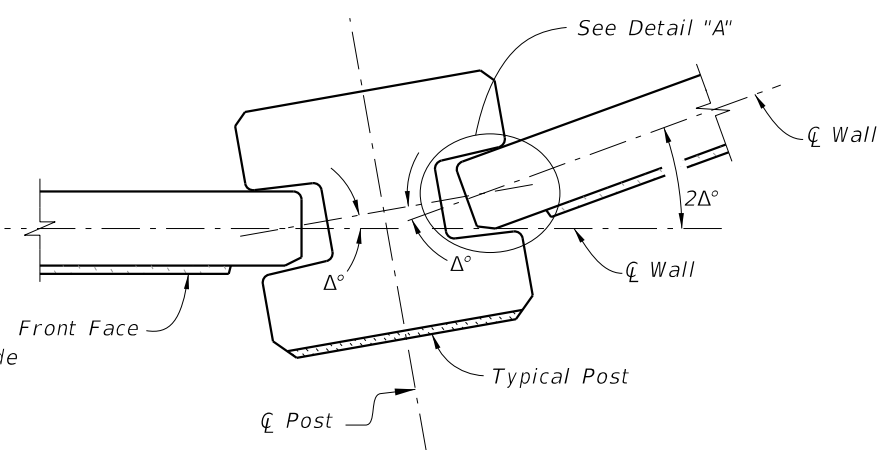

PIVOTING JOINT DETAILS

NOTE: Shop Drawings shall include specific pivoting point details of panel ends at locations where the deflection angle ($2\Delta^\circ$) between panels exceeds 20° .

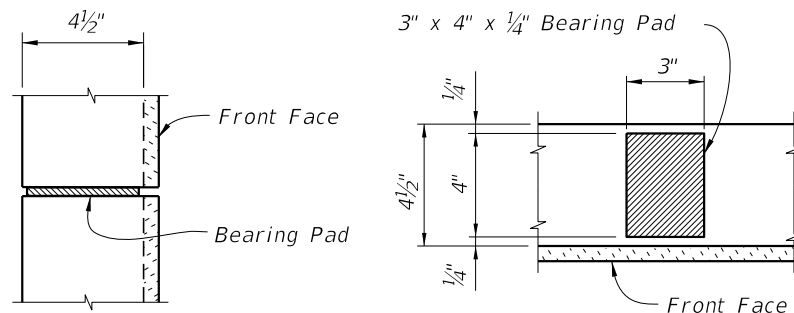

SECTION D-D

SECTION E-E

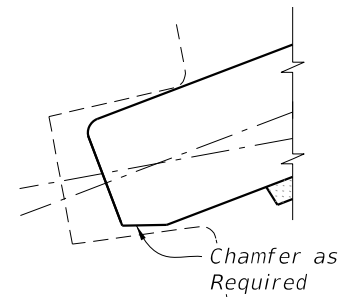

DETAIL "A"
(Back Face Chamfer Shown
Front Face Chamfer Similar)

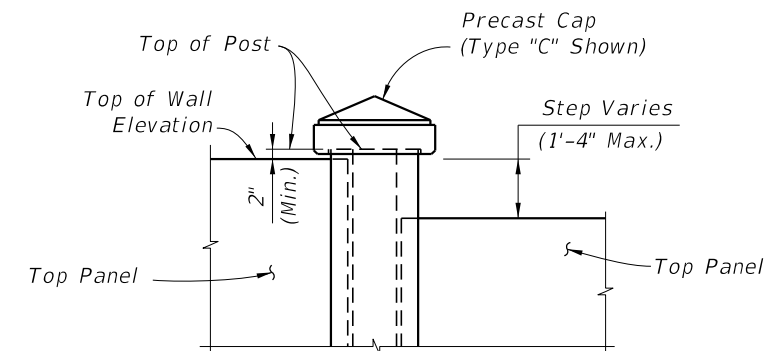

ELEVATION STEP AT TOP OF WALL
(Precast Panel Cap not Shown)

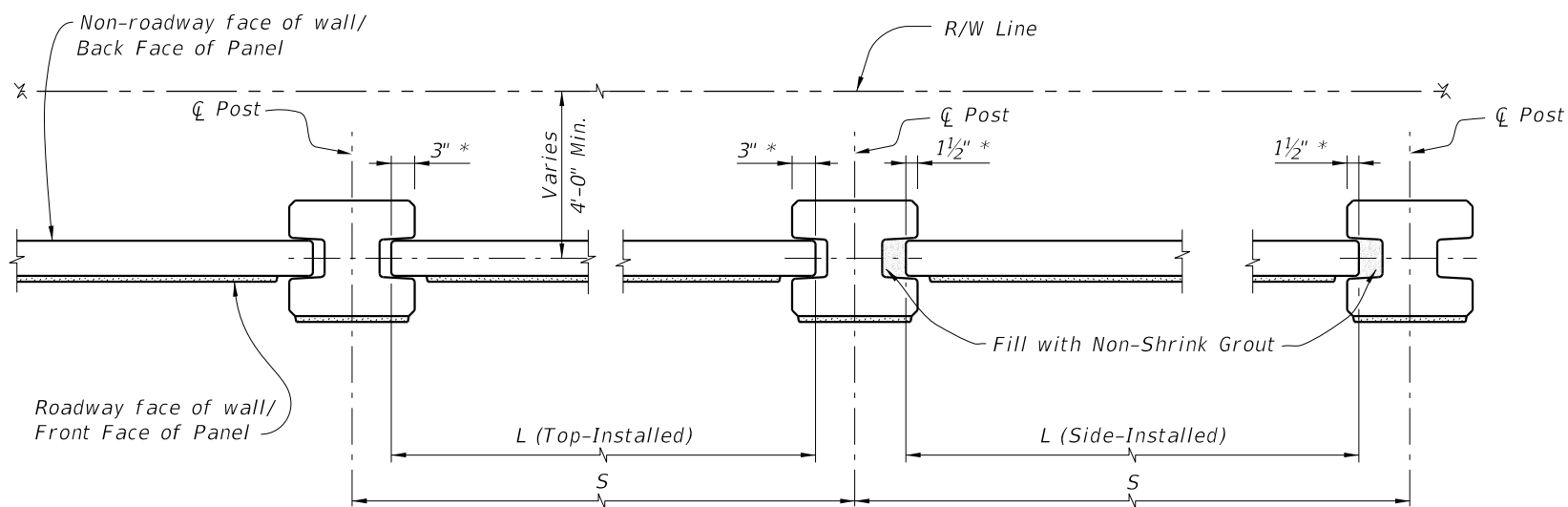

TYPICAL PLAN

* Nominal embedment (not including tolerances)

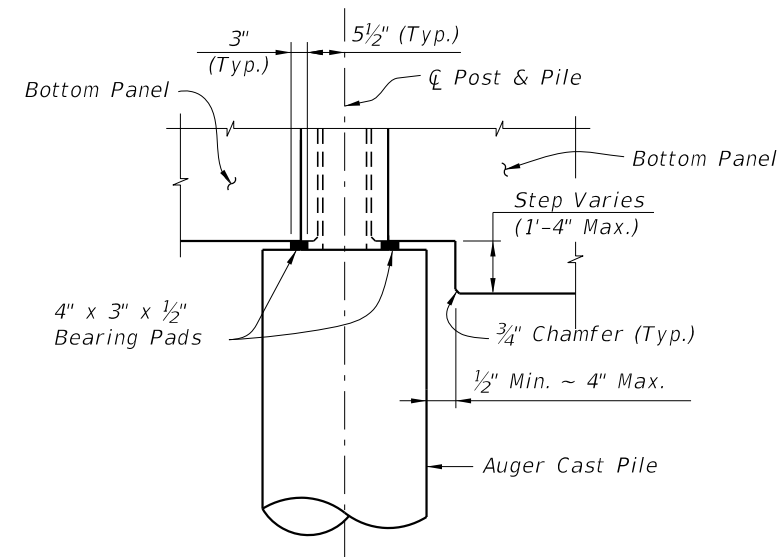

ELEVATION STEP AT BOTTOM OF WALL

PRECAST OPTION - TYPICAL DETAILS

10/20/2022 8:52:54 AM

LAST REVISION 11/01/17	REVISION	DESCRIPTION:
---------------------------	----------	--------------



FY 2023-24
STANDARD PLANS

PERIMETER WALLS

INDEX
534-250

SHEET
4 of 10

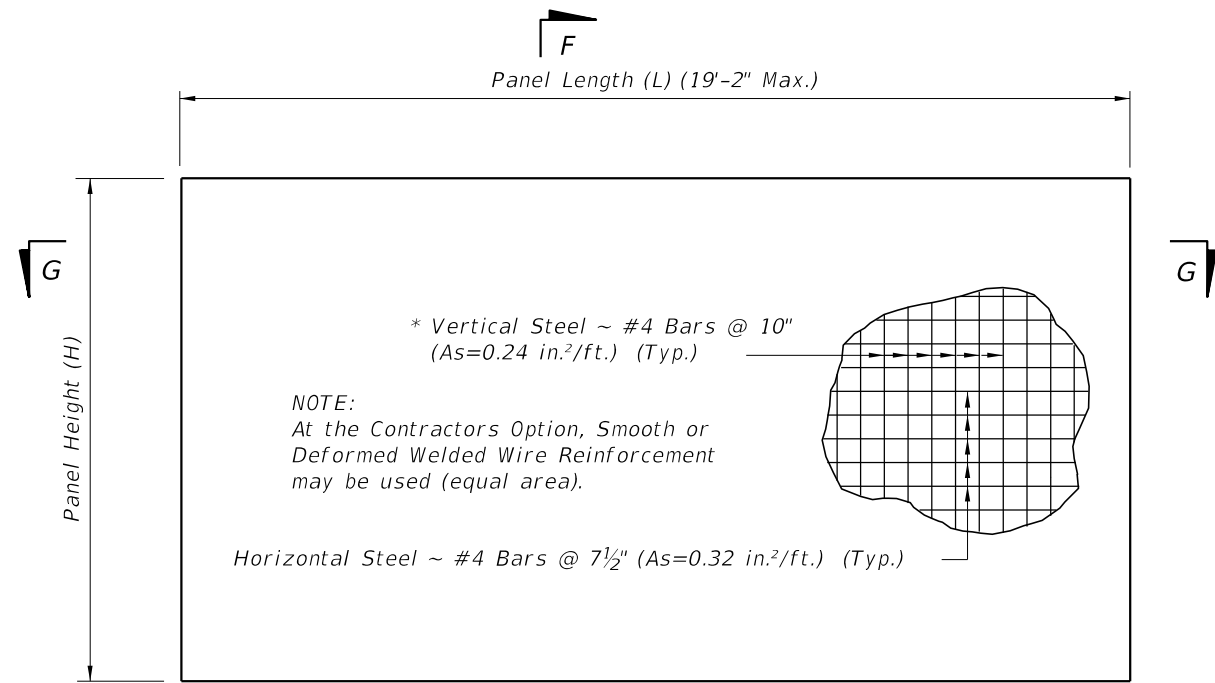

* Vertical Steel ~ #4 Bars @ 10"
(As=0.24 in.²/ft.) (Typ.)

NOTE:
At the Contractors Option, Smooth or
Deformed Welded Wire Reinforcement
may be used (equal area).

Horizontal Steel ~ #4 Bars @ 7½"
(As=0.32 in.²/ft.) (Typ.)

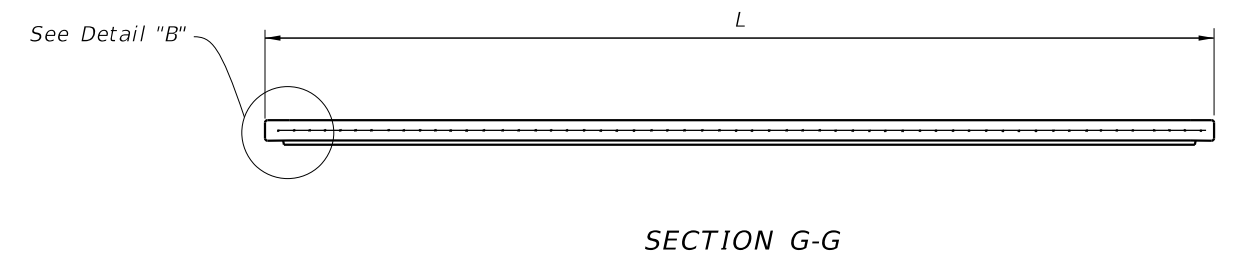

SECTION G-G

TYPICAL PANEL ELEVATION

* In lieu of utilizing the standard pick up points below, panels may be cast vertically or cast horizontally then tilted upright using tilt-tables prior to lifting from form. In this case, pick points must be placed in the top of panels only and transported maintaining the vertical orientation. If these criteria are met, the vertical steel may be reduced to #4 Bars @ 1'-3" (As=0.16 in.²/ft.).

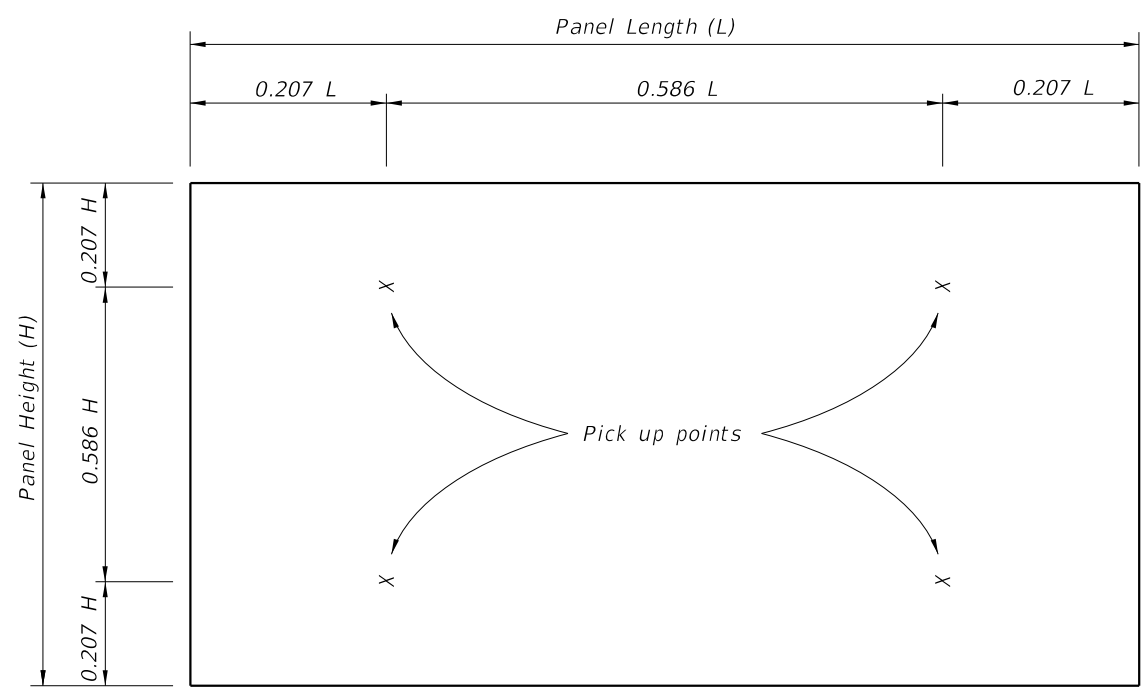

STANDARD PICK UP POINTS FOR PANELS
(Panels shall be rotated about long axis only)

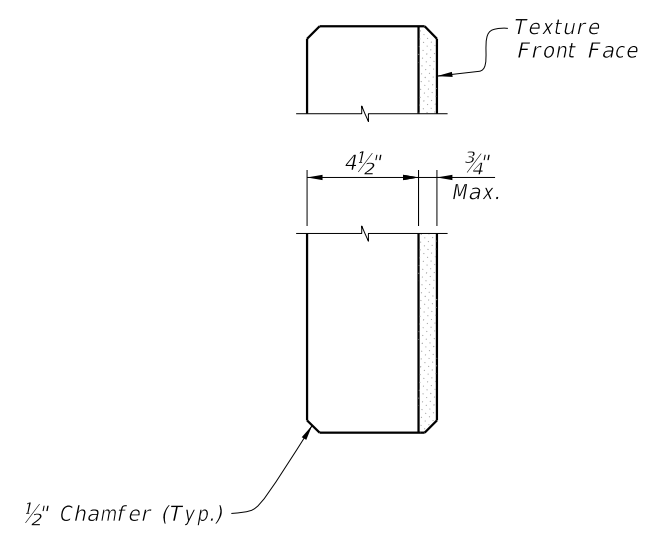

SECTION F-F

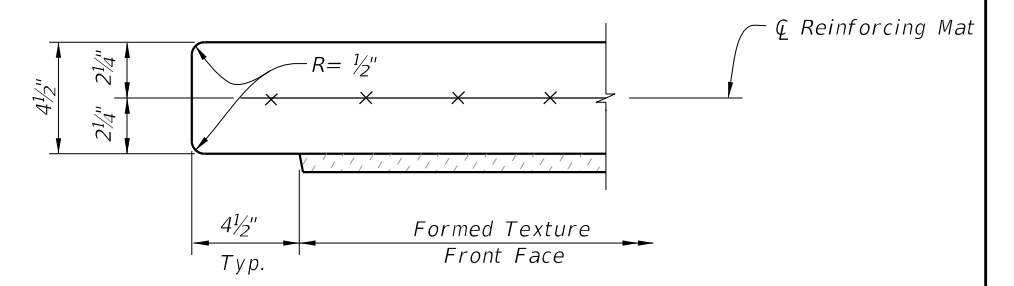

DETAIL "B" - TOP-INSTALLED
(Typ. Both Ends)

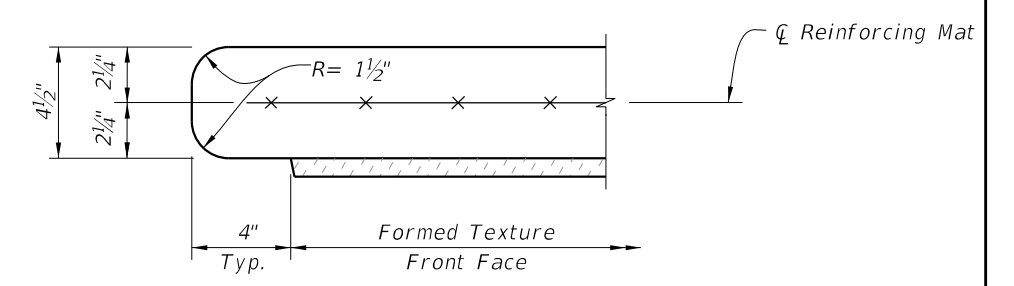

DETAIL "B" - SIDE-INSTALLED
(Typ. Both Ends)

PRECAST OPTION - TYPICAL PANEL DETAILS

10/20/2022 8:52:55 AM

LAST REVISION 11/01/14	DESCRIPTION:		FY 2023-24 STANDARD PLANS	PERIMETER WALLS	INDEX 534-250	SHEET 5 of 10
---------------------------	--------------	--	------------------------------	-----------------	------------------	------------------

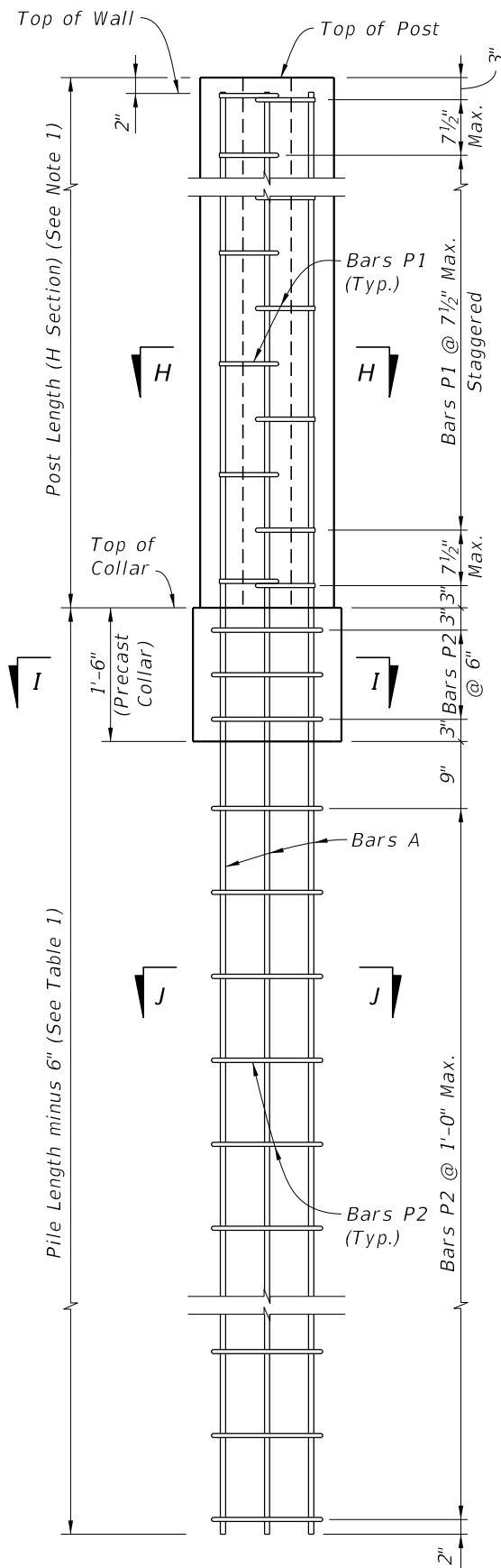

TYPICAL POST

STANDARD POST REINFORCEMENT

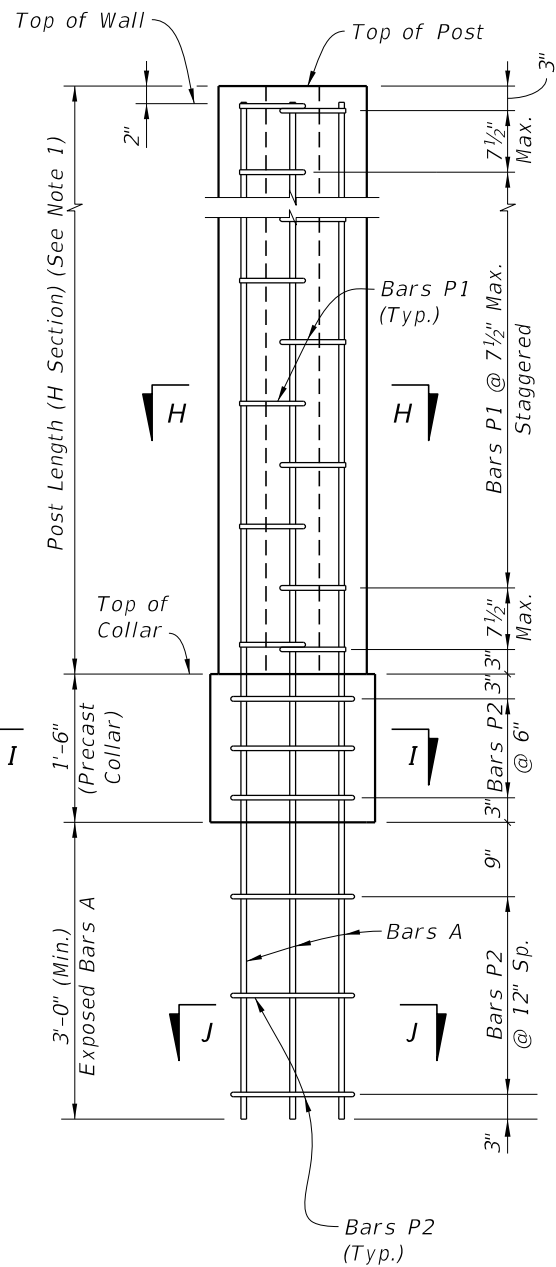

LOW CLEARANCE OPTION

NOTES:
1. See Shop Drawing for Post Lengths.

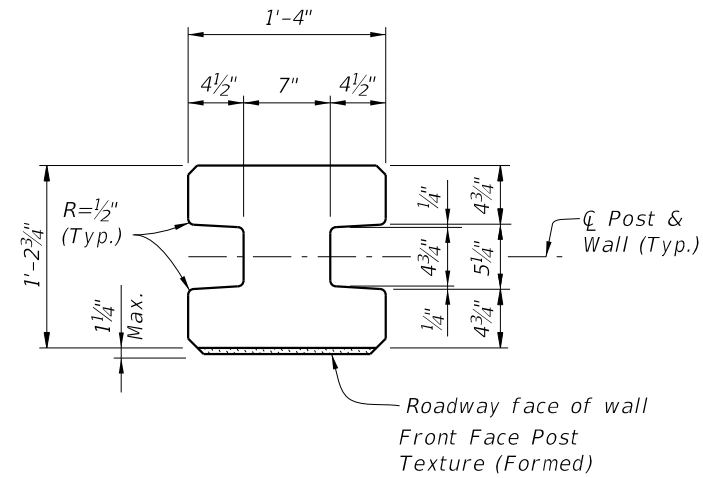

TYPICAL POST SECTION
(H Section)

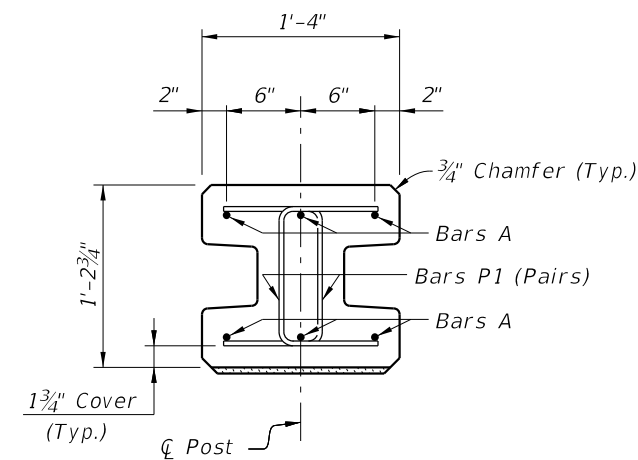

SECTION H-H
(H Section - Above Collar)

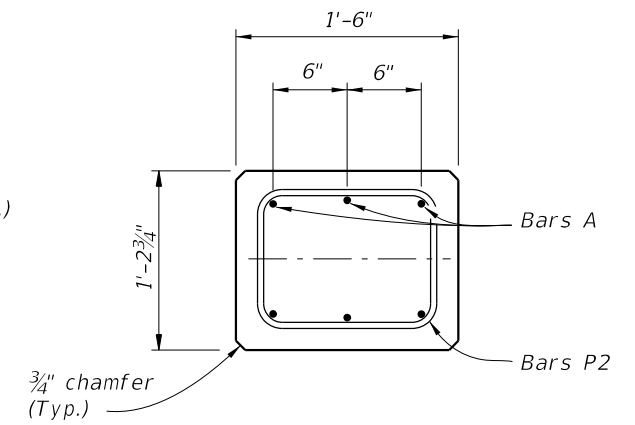

SECTION I-I
Precast Collar

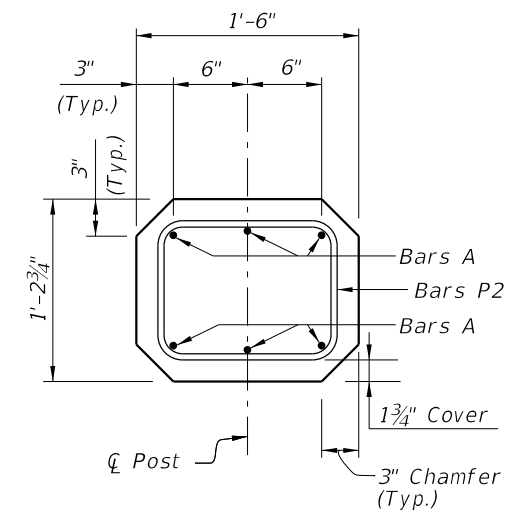

SECTION I-I
(for Low Clearance Option)

Wind Speed (MPH)	Pile Length	Bars A	Bars P1 thru P6	Bars S1
130	12'-0"	#5	#3	#4
150	13'-6"	#5	#3	#4
170	15'-0"	#6	#3	#4

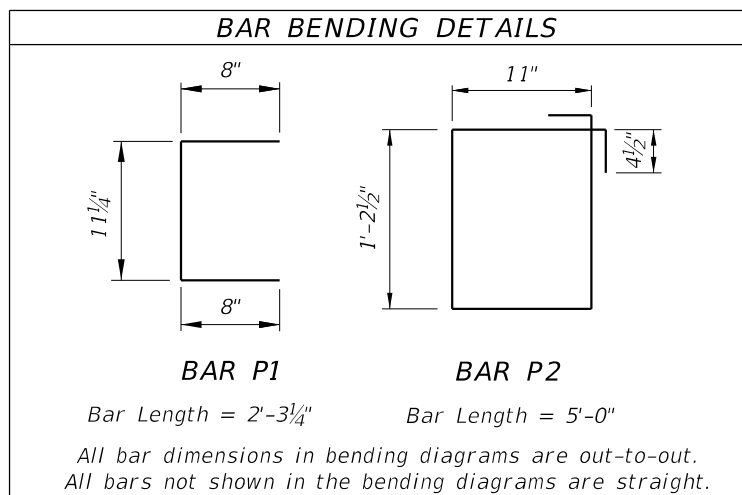

Bar Length = 2'-3 1/4" Bar Length = 5'-0"
All bar dimensions in bending diagrams are out-to-out.
All bars not shown in the bending diagrams are straight.

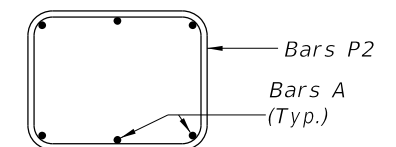

SECTION J-J

PRECAST OPTION - STANDARD POST DETAILS

10/20/2022 8:52:56 AM

LAST REVISION	DESCRIPTION:
11/01/17	



FY 2023-24
STANDARD PLANS

PERIMETER WALLS

INDEX
534-250

SHEET
6 of 10

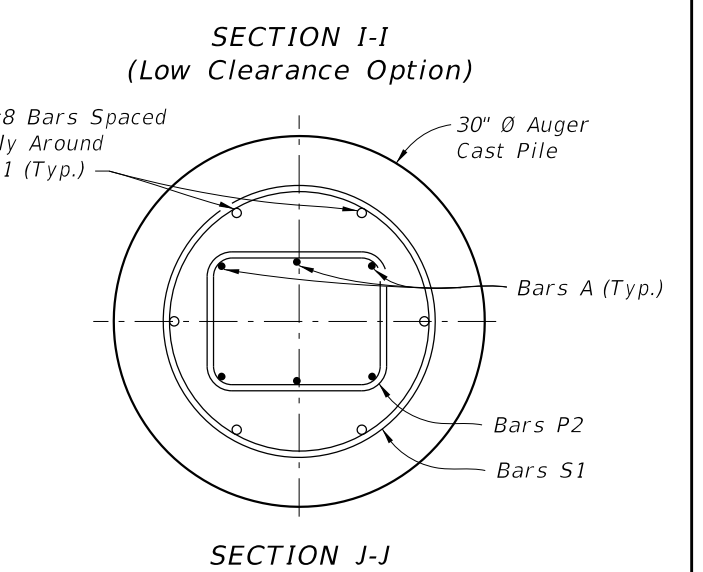
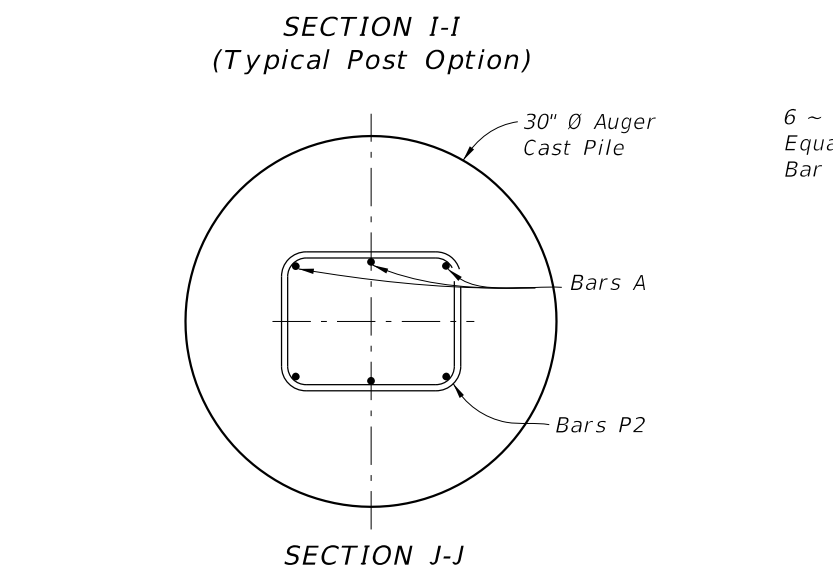
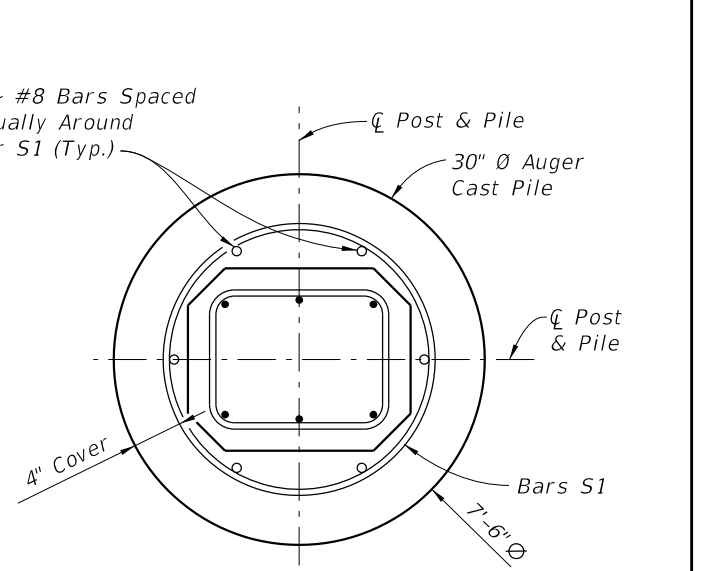
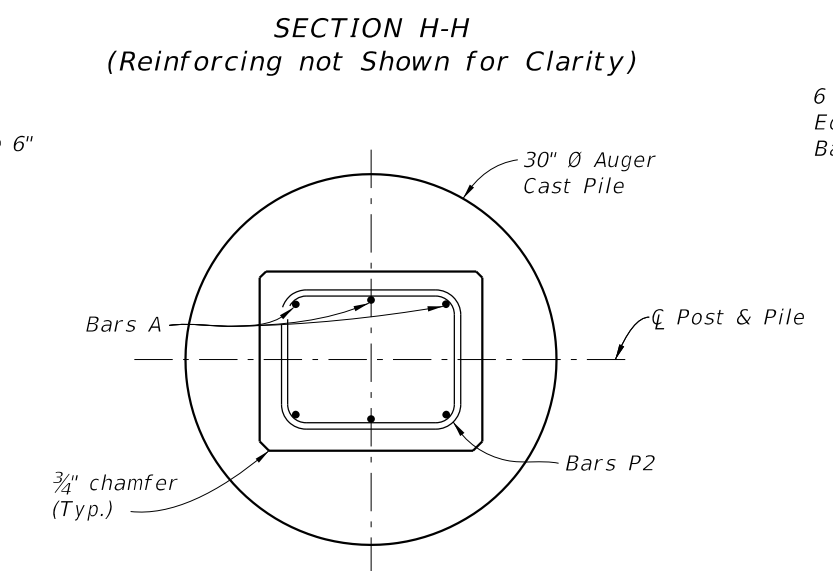
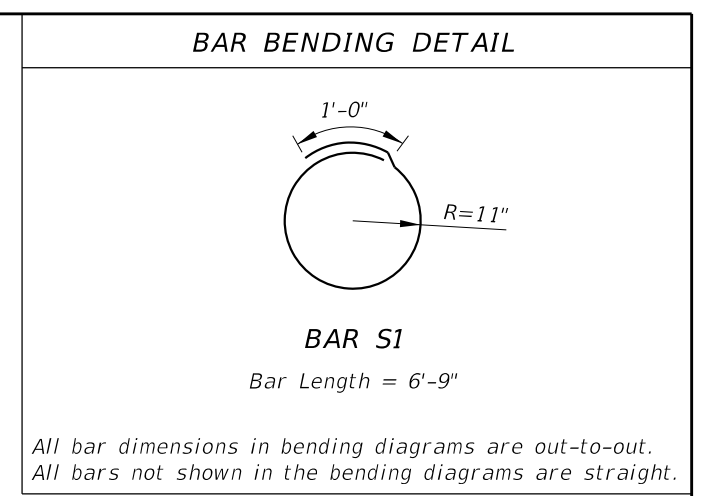
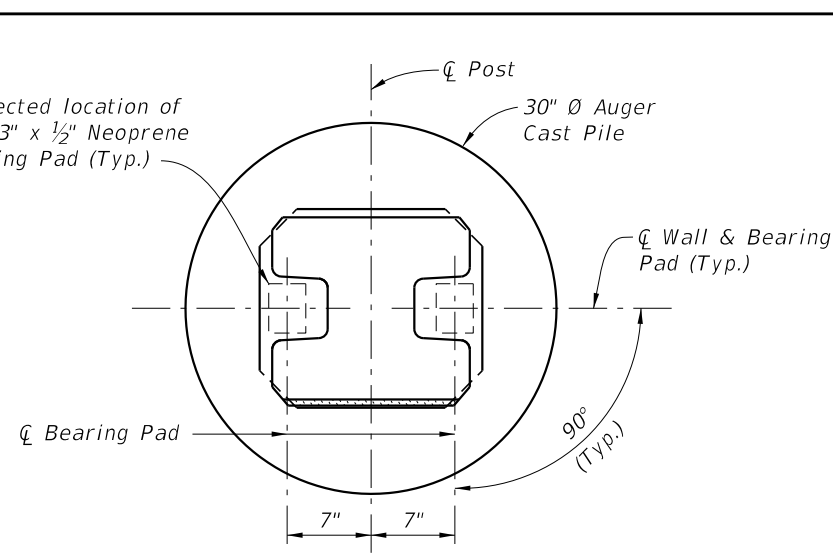
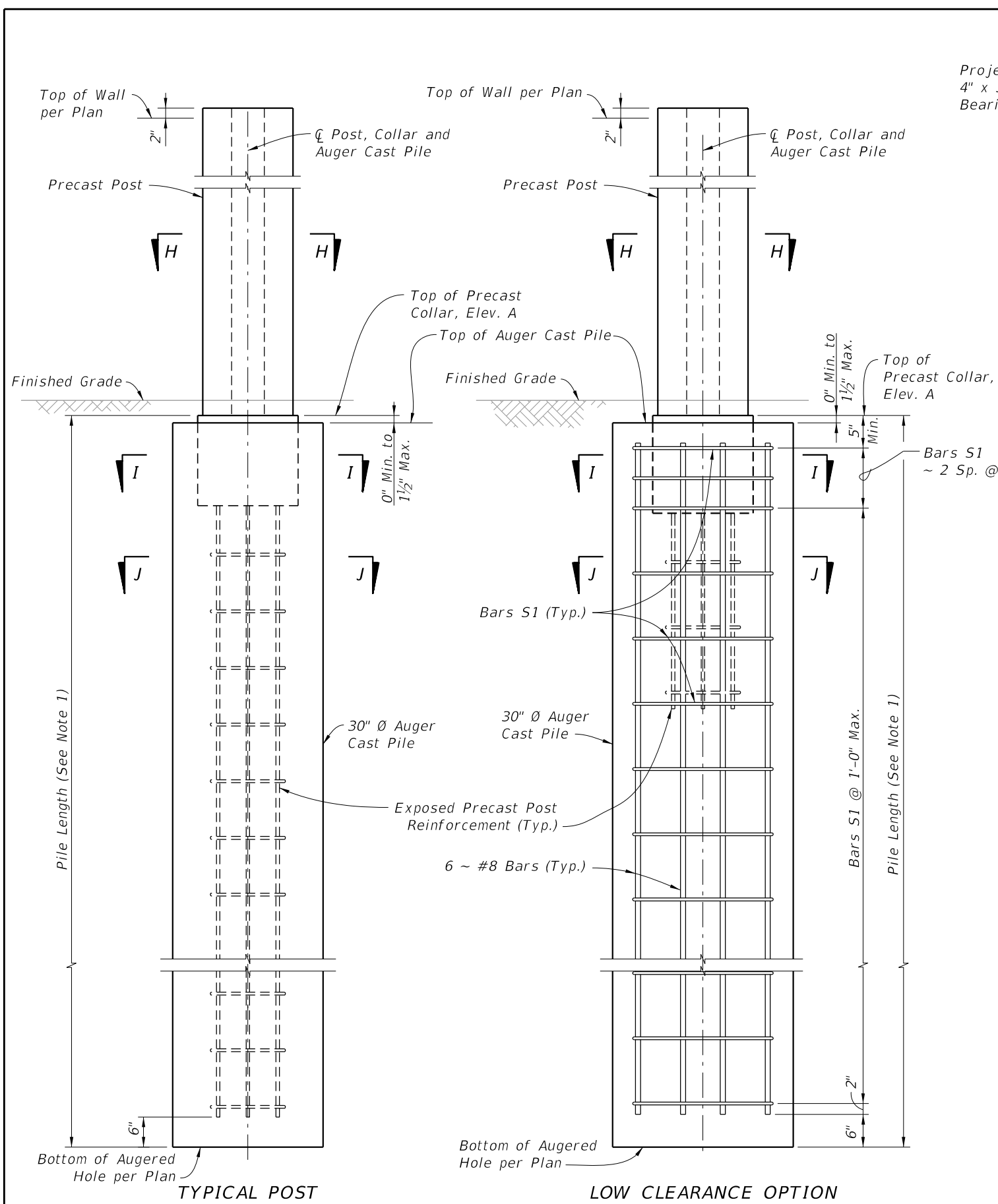

- Notes:
1. For Reinforcing Steel Sizes and Pile Lengths, see Table 1, Sheet 6.
 2. For Corner Posts, see Sheet 8.
 3. For Typical Post Section Dimensions, see Sheet 6.

STANDARD POST PLACEMENT IN AUGER CAST PILE
 (Standard Post Shown, 45° and 90° Corner Posts Similar)

PRECAST OPTION - POST PLACEMENT & PILE REINFORCING STEEL DETAILS

10/20/2022 8:52:57 AM

LAST REVISION 11/01/16	REVISION	DESCRIPTION:		FY 2023-24 STANDARD PLANS	PERIMETER WALLS	INDEX 534-250	SHEET 7 of 10
---------------------------	----------	--------------	--	------------------------------	-----------------	------------------	------------------

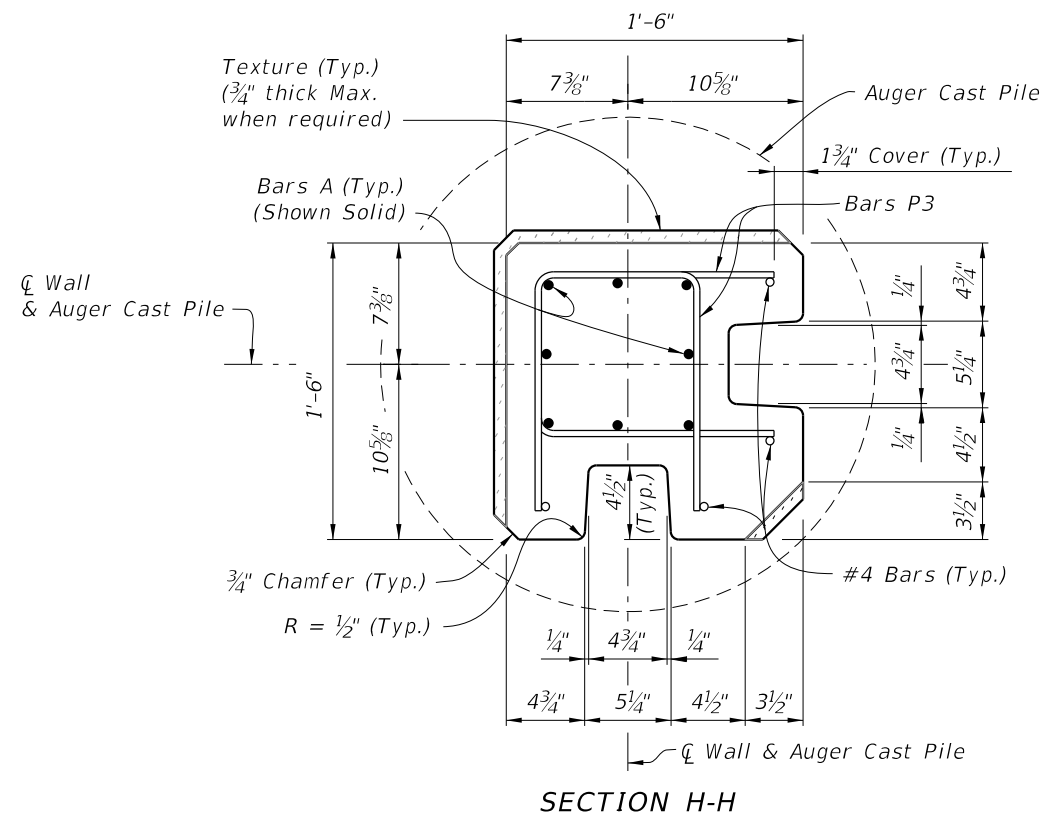

SECTION H-H

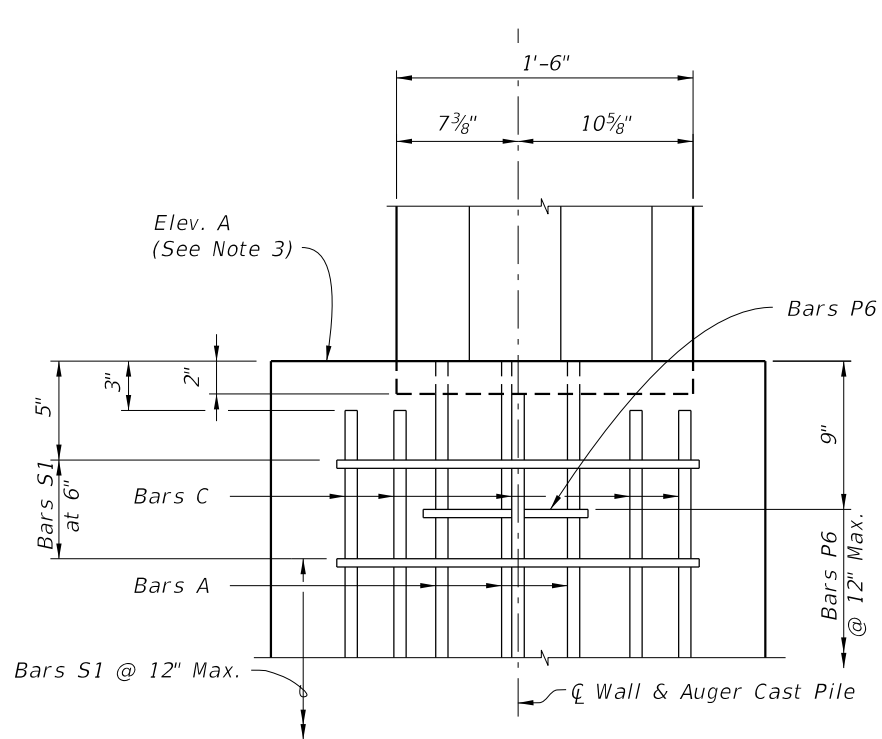

ELEVATION VIEW
(Low Clearance Shown)

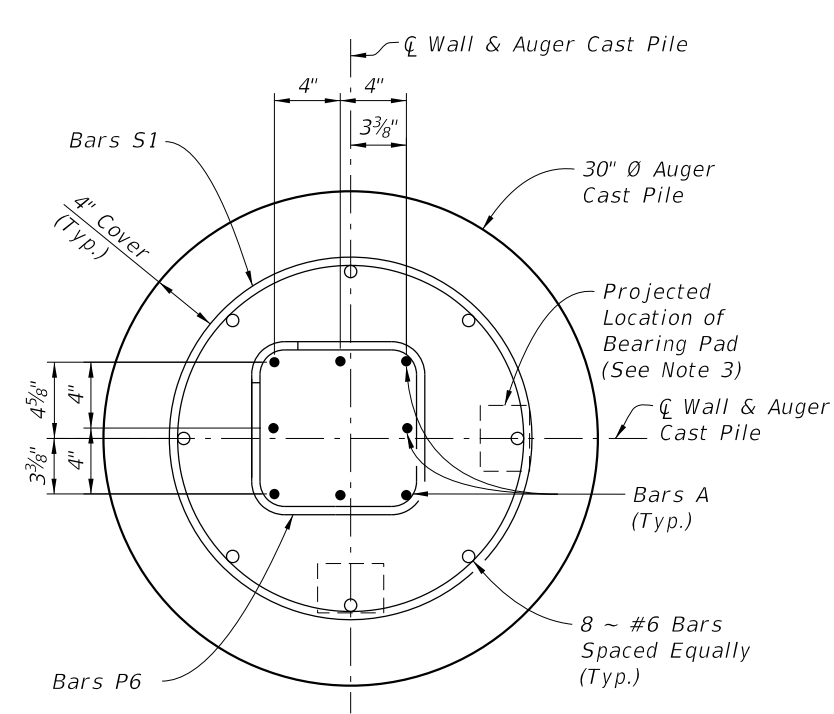

SECTION I-I
(See Note 3)

SPECIAL POST FOR 90° CORNERS

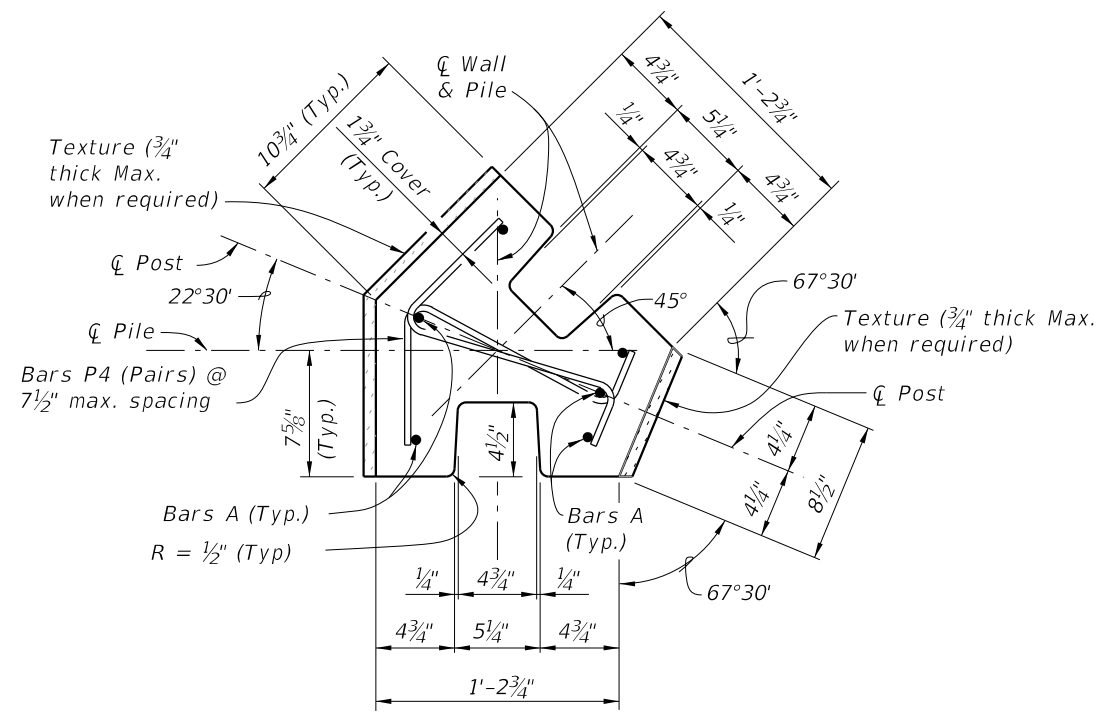

SECTION H-H

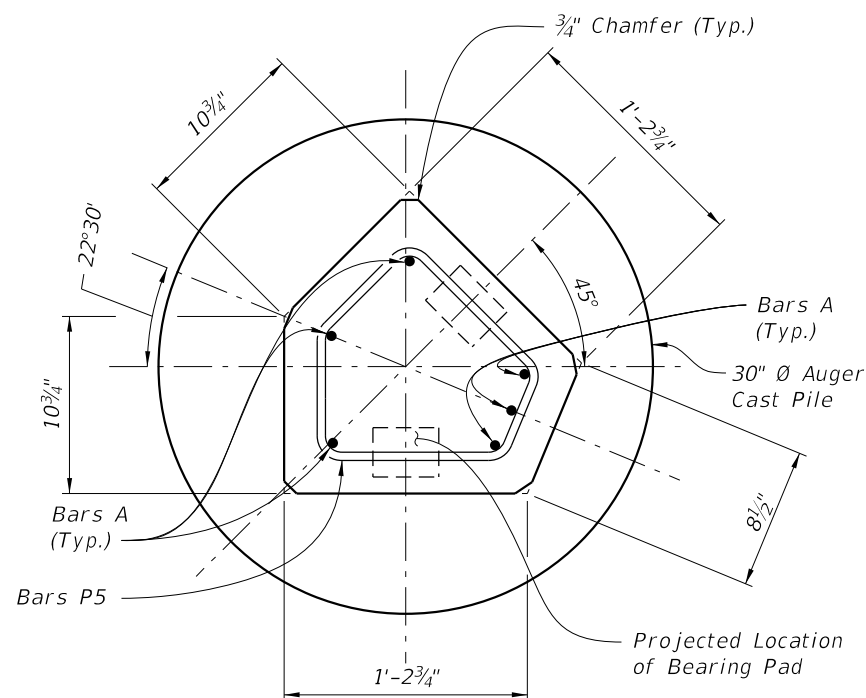

SECTION I-I
(Precast Collar)

BAR BENDING DETAILS

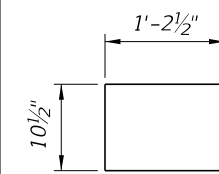

BAR P3
(90° Corner)
Bar Length = 3'-3 1/2"

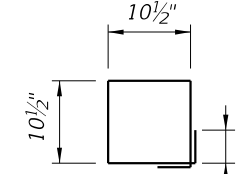

BAR P6
(90° Corner)
Bar Length = 4'-2"

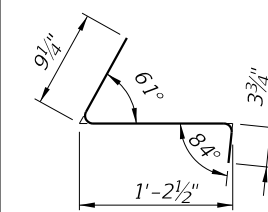

BAR P4
(45° Corner)
Bar Length = 2'-3 1/2"

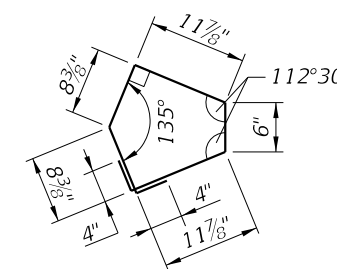

BAR P5
(45° Corner)
Bar Length = 4'-6 1/2"

All bar dimensions in bending diagrams are out-to-out.
All bars not shown in the bending diagrams are straight.

SPECIAL POSTS FOR 45° CORNERS

- NOTES:
1. For Reinforcing Steel Sizes, and Foundation Dimensions, see Table 1 Sheet 6.
 2. For location of Section H-H and I-I, see Sheet 6.
 3. The Bearing area beneath Neoprene Pads is formed by top of Auger Cast Pile Grout.

PRECAST OPTION - SPECIAL CORNER POSTS

10/20/2022 8:52:56 AM

LAST REVISION 11/01/17	DESCRIPTION:		FY 2023-24 STANDARD PLANS	PERIMETER WALLS	INDEX	SHEET
			534-250		8 of 10	

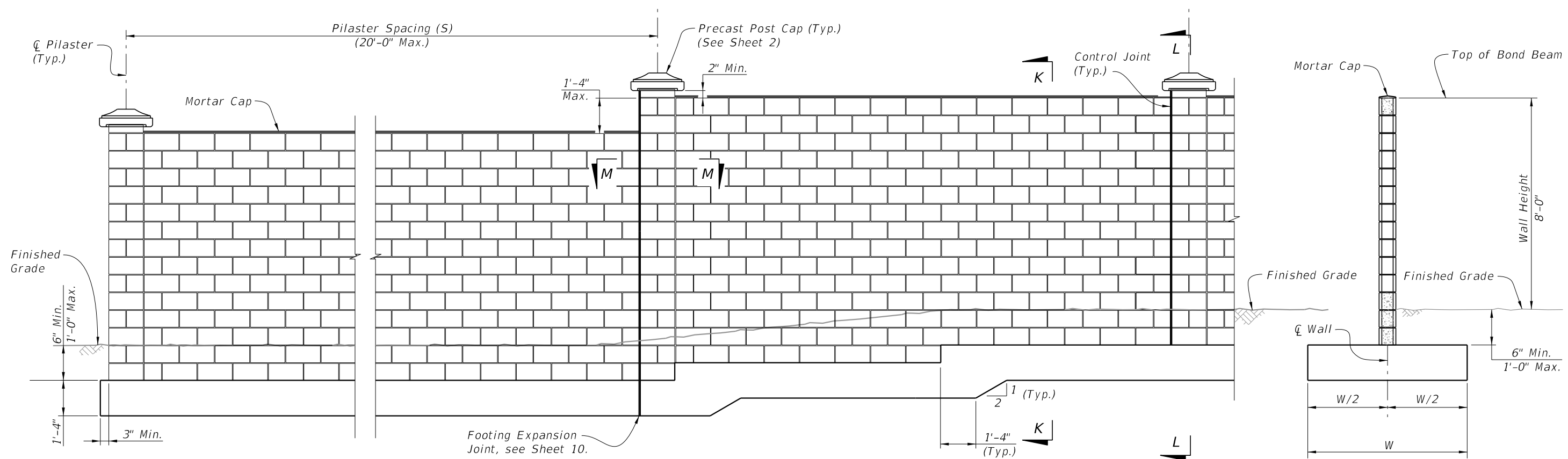

TYPICAL ELEVATION
(T-Footing Shown, Trench Footing Similar)

SECTION K-K
(Shown at Cell Without Vertical Reinforcing)

Wind Speed Category	Masonry Walls (8x8x16)		Foundations		
	Bars V1	SV Spacing	Bars F1 & F2	T-Footing Width (W)	Trench Footing Depth (D)
	130	#5	2'-8"	#5	4'-4"
150	#5	2'-0"	#5	5'-0"	6'-4"
170	#5	1'-4"	#5	6'-0"	7'-0"

- Notes:
- End vertical reinforcing bars 1/2" from top of bond beam blocks and horizontal bars 1/2" from edge of control joints.
 - Do not continue horizontal #4 Bond beam reinforcing through control joint.
 - Use stainless steel joint stabilizing anchors spaced at 16" vertically at all control joints. Install per manufacturers instructions.
 - Seal Control Joints with backer rod and Type "A" silicone sealant (top and both sides).
 - See Sheet 10 for Bar placement details.
 - For Pilaster Cap Details, see Sheet 2.

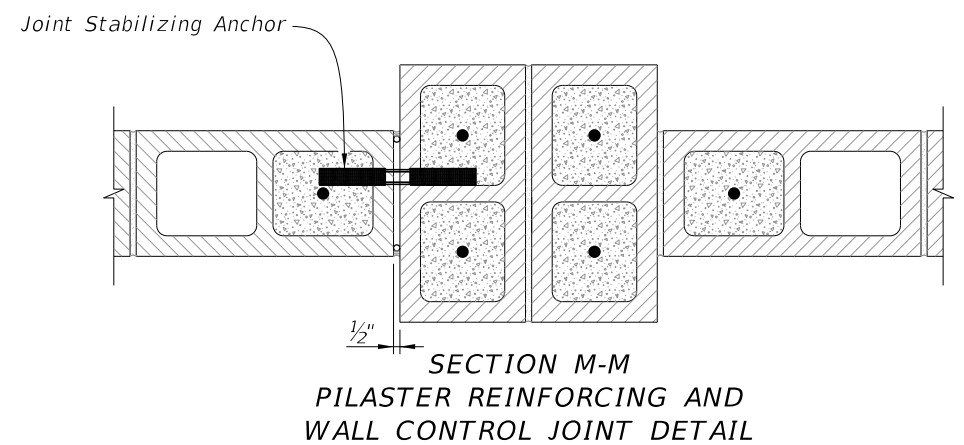

SECTION M-M
PILASTER REINFORCING AND
WALL CONTROL JOINT DETAIL

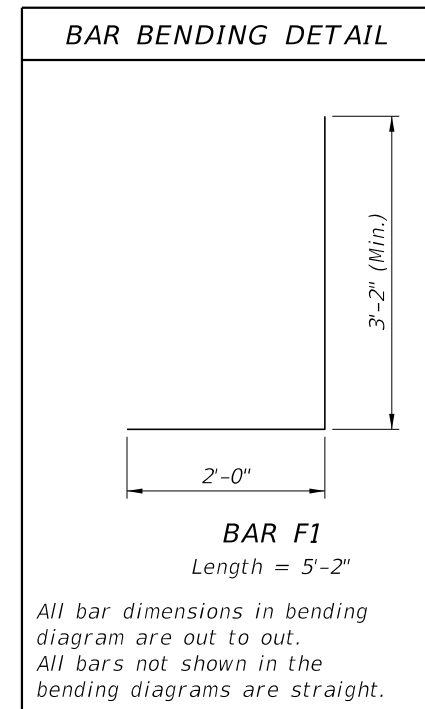

MASONRY OPTION

10/20/2022 8:52:59 AM

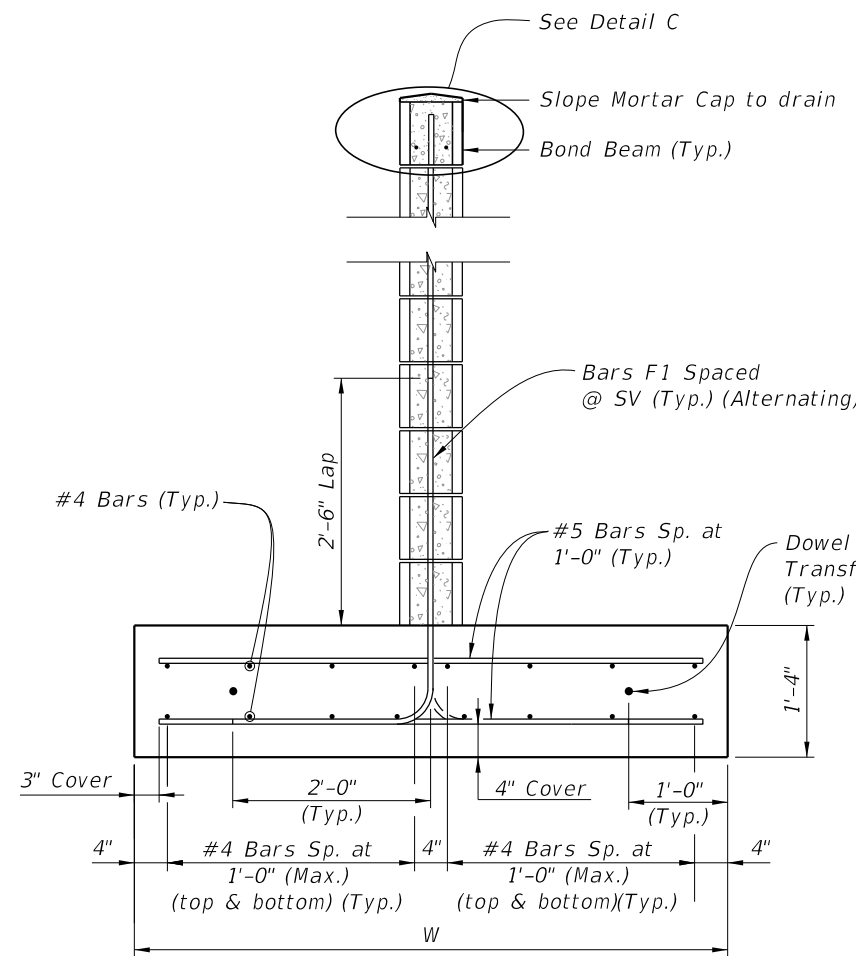

**SECTION K-K
TYPICAL WALL SECTION
WITH T-FOOTING**

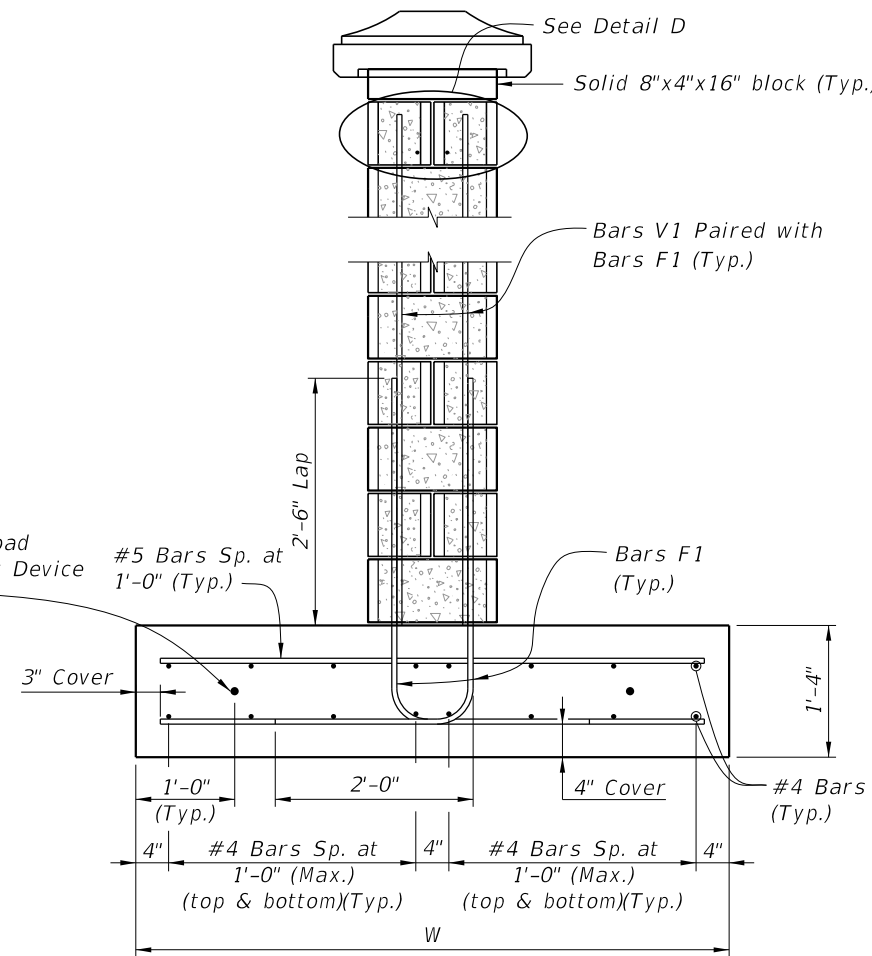

**SECTION L-L
PILASTER SECTION
WITH T-FOOTING**

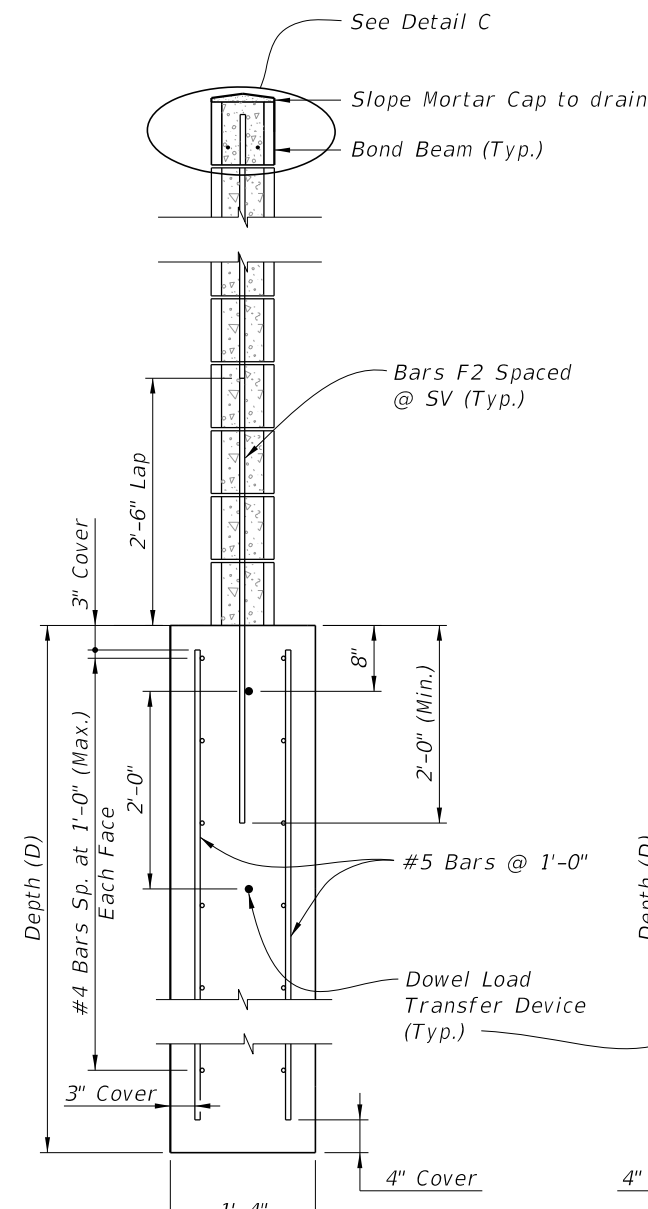

**SECTION K-K
TYPICAL WALL SECTION
WITH TRENCH FOOTING**

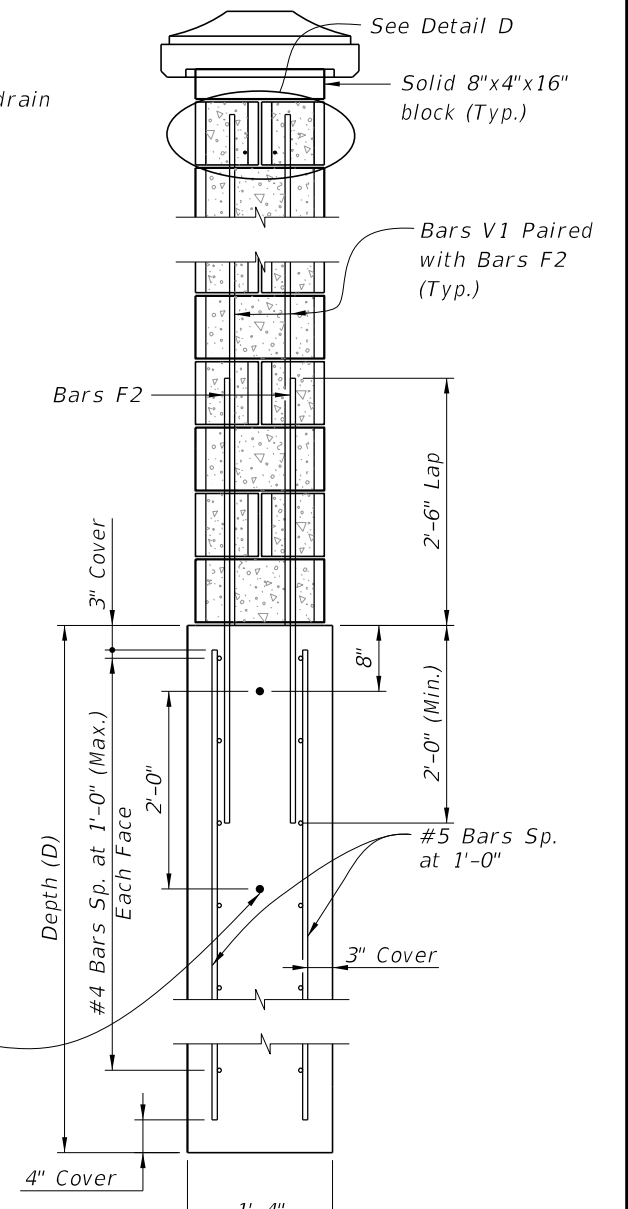

**SECTION L-L
TYPICAL PILASTER SECTION
WITH TRENCH FOOTING**

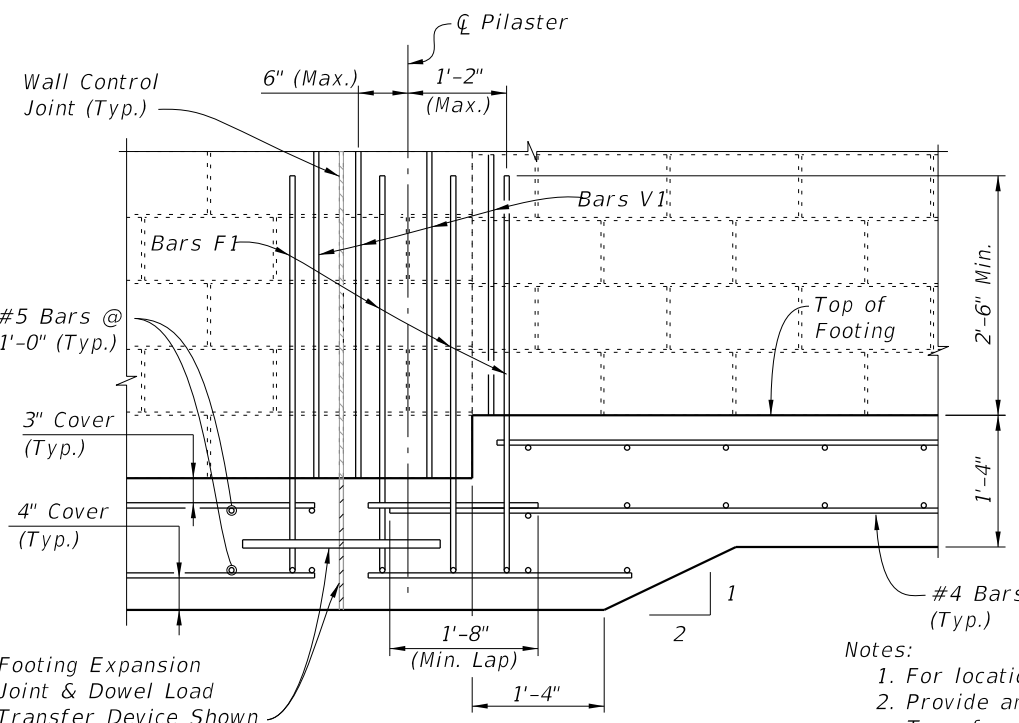

**REINFORCING AT PILASTER WITH EXPANSION JOINT
(Step Shown, without Step Similar)
(T-Footing Shown, Trench Footing Similar)**

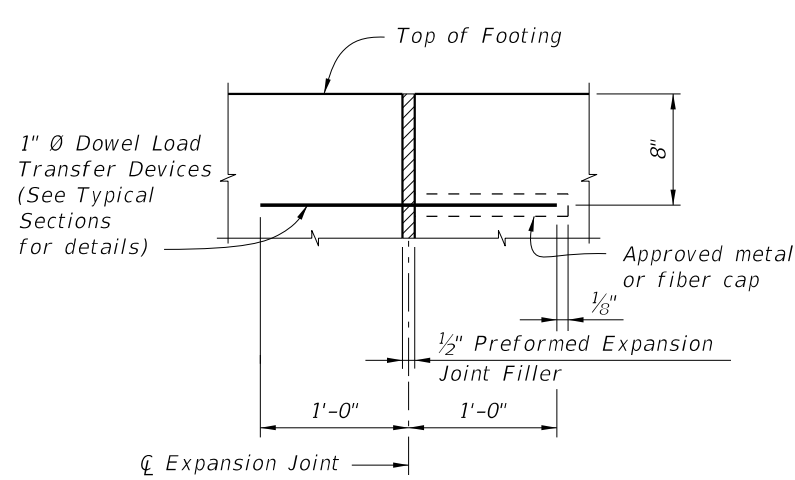

EXPANSION JOINT DETAILS

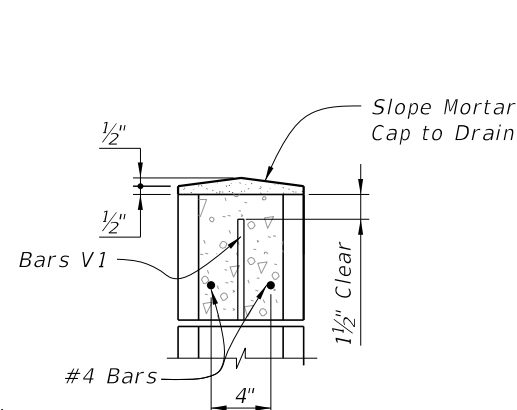

DETAIL C

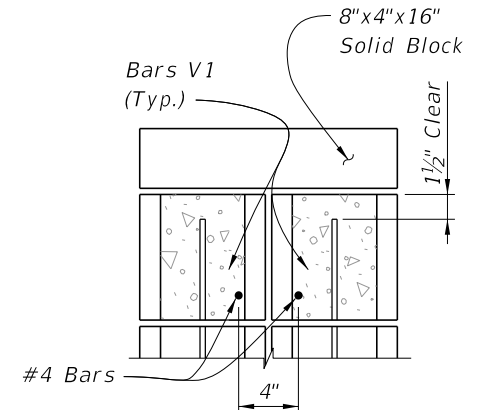

DETAIL D

MASONRY OPTION

- Notes:
1. For location of Sections K-K and L-L see Sheet 9.
 2. Provide and install 1/2" Preformed Expansion Joints with 2 ~ 1" Ø Dowel Load Transfer Devices at 90' Max. as shown. See Sections L-L for placement details.
 3. For Reinforcing sizes and spacings, see Table 2, Sheet 9.
 4. Pairs F1, V1 are required in the wall cells on both sides of pilasters, plus a pair in each pilaster cell. Space wall reinforcing per Table 2, Sheet 9.

10/20/2022 8:53:01 AM

LAST REVISION 11/01/16	DESCRIPTION:	 FY 2023-24 STANDARD PLANS	PERIMETER WALLS	INDEX	SHEET
				534-250	10 of 10

SHEET	CONTENTS
1	General Notes; Index Contents
2	General, TL-3 Guardrail - Installed Plan and Elevation
3	Low-Speed, TL-2 Guardrail - Installed Plan and Elevation
4	W-Beam and Thrie-Beam Panel Details
5	Post and Offset Block Details
6	Guardrail Sections - Heights and Adjacent Slopes
7	End Treatment - Approach Terminal Geometry, Parallel
8	End Treatment - Approach Terminal Geometry, Curbed and Double Faced
9	End Treatment - Trailing Anchorage
10	End Treatment - Component Details
11	End Treatment - Controlled Release Terminal (CRT) System
12	Layout for CRT System - Side Roads and Driveways
13	Approach Transition Connection to Rigid Barrier - General, TL-3
14	Approach Transition Connection to Rigid Barrier - General, TL-3 - Curb Connections
15	Approach Transition Connection to Rigid Barrier - Low-Speed, TL-2
16	Approach Transition Connection to Rigid Barrier - Low-Speed, TL-2 - Curb Connections
17	Approach Transition Connection to Rigid Barrier - Details
18	Approach Transition Connection to Rigid Barrier - Double Faced Guardrail
19	Layout to Rigid Barrier - Approach Ends
20	Layout to Rigid Barrier - Approach Ends with Double Faced Guardrail Layout to Rigid Barrier - Trailing Ends Trailing End Transition Connection to Rigid Barrier
21	Rub Rail Details
22	Pedestrian Safety Treatment - Pipe Rail
23	Modified Mount - Special Steel Post for Concrete Structure Mount; Modified Mount - Encased Post for Shallow Mount; Modified Mount - Frangible Leave-Out for Concrete Surface Mount
24	Barrier Delineators - Post Mounted; Clear Space - Reduced Post Spacing for Hazards; 5/8" Button-Head Bolt System

GENERAL NOTES:

1. **INSTALLATION:** Construct guardrail in accordance with Specification 536.

This Index, along with the plans and the manufacturers' drawings on the Approved Products List (APL), is sufficiently detailed for installation of General Guardrail, Low-Speed Guardrail, End Treatment assemblies, and their connecting options shown herein. This precludes requirements for shop drawing submittals unless otherwise specified in the plans.

2. **COMPATIBILITY:** The General Guardrail in this Index is based on the Midwest Guardrail System (MGS) design, with an approximate height of 31" at the top of the Panel (2'-1" mounting height at vertical \bar{C} of Panel) and a midspan panel splice as shown on Sheet 2. Guardrail components included on the APL, which are compatible with this Index, may also be identified as 31" or MGS Guardrail.

3. **STANDARD COMPONENTS:** Standard guardrail components, including posts, panels, and bolt systems, are based on the Task Force 13 Publication: Guide to Roadside Hardware Components (<http://tf13.org/Guides/componentGuide/>).

4. **BUTTON-HEAD BOLTS:** Install Button-Head Bolts where indicated using bolts, nuts, and washers as defined on Sheet 24. Place washers under nuts. Do not place washers between bolt heads and panels, except where otherwise shown in this Index.

5. **HEX-HEAD BOLTS:** Install Hex-Head Bolts where indicated using bolts, nuts, and washers in accordance with material properties of Specification 967. Place washers under nuts.

6. **MISCELLANEOUS ASPHALT PAVEMENT:** Install Miscellaneous Asphalt Pavement where indicated with a tolerance of $\pm 1/2$ " depth and in accordance with Specification 339.

7. **ADJACENT SIDEWALKS & SHARED USE PATHS:** When guardrail posts are placed within 4'-0" of a sidewalk or shared use path, use timber posts, or use steel posts only if treated with Pipe Rail as shown on Sheet 22.

When timber posts are used, one of the following safety treatments is required for the bolt(s) protruding from the back face of the posts:

- a. After tightening the nut, trim the protruding post bolt flush with the nut and galvanize per Specification 562.
- b. Use post bolts 15" in length and countersink the washer and nut between 1" and 1 1/2" deep into the back face of the post.
- c. Use 15" post bolts with sleeve nuts and washers.

When End Treatment posts are within 4'-0" of a sidewalk or shared use path, steel posts are not permitted within the End Treatment segment. Terminate the Pipe Rail outside of End Treatment segments, as noted per Sheet 22.

8. **NESTED W-BEAM:** Where called for in the plans, install two W-Beam Panels mounted flush per location, securing all panels with Button-Head Bolts threaded through aligned slots and holes. 2" Button-Head Bolts are permitted for panel splice locations.

9. **CONNECTION TO RIGID BARRIER:** The connections to Rigid Barrier in this Index only apply to newly constructed bridge Traffic Railing and Concrete Barrier or where the complete Approach Transition Connection to Rigid Barrier shown herein can be installed without conflicting with existing Traffic Railings, structures, or approach slabs.

For connecting guardrail to existing bridge Traffic Railings, see Indexes 536-002, 521-404, and 521-405.

10. **CONNECTION TO EXISTING GUARDRAIL:** Where a transition to existing guardrail at 27" height is required, linearly transition the new guardrail height over a distance ranging from 25'-0" to 31'-3". Height transitions must occur outside of End Treatment and Approach Transition segments.

Provide an immediate transition to the required midspan panel splice using the available panel options on Sheet 4 (9'-4 1/2" or 15'-7 1/2" panel). Alternatively, this transition to midspan panel splice may be achieved by installing a single reduced post spacing of 3'- 1 1/2" within the new guardrail, immediately adjacent to the connection location.

11. **PLANS CALLOUTS:** Begin/End Station labels are shown throughout this Index as they correspond to the station and offset callouts specified in the plans.

In the plans, Begin/End Guardrail Station refers to the General TL-3 Guardrail Pay Item, and it may be abbreviated as Begin/End GR. Station. Where the Low-Speed TL-2 Guardrail Pay Item is specifically required, the callout in the plans will then specify Begin/End TL-2 GR. Station.

12. **QUANTITY MEASUREMENT:** Measure guardrail and corresponding components as defined in Specification 536. The Guardrail length is measured along the centerline of installed Panels, between the points labeled Begin/End Guardrail Station shown on the following Index Sheets and defined in the plans (typically measured from the \bar{C} of the panel's post bolt slots at the approach/trailing ends).

10/20/2022 8:53:01 AM

LAST REVISION 11/01/19	REVISION	DESCRIPTION:	 FY 2023-24 STANDARD PLANS	GUARDRAIL	INDEX 536-001	SHEET 1 of 24
---------------------------	----------	--------------	---	------------------	------------------	------------------

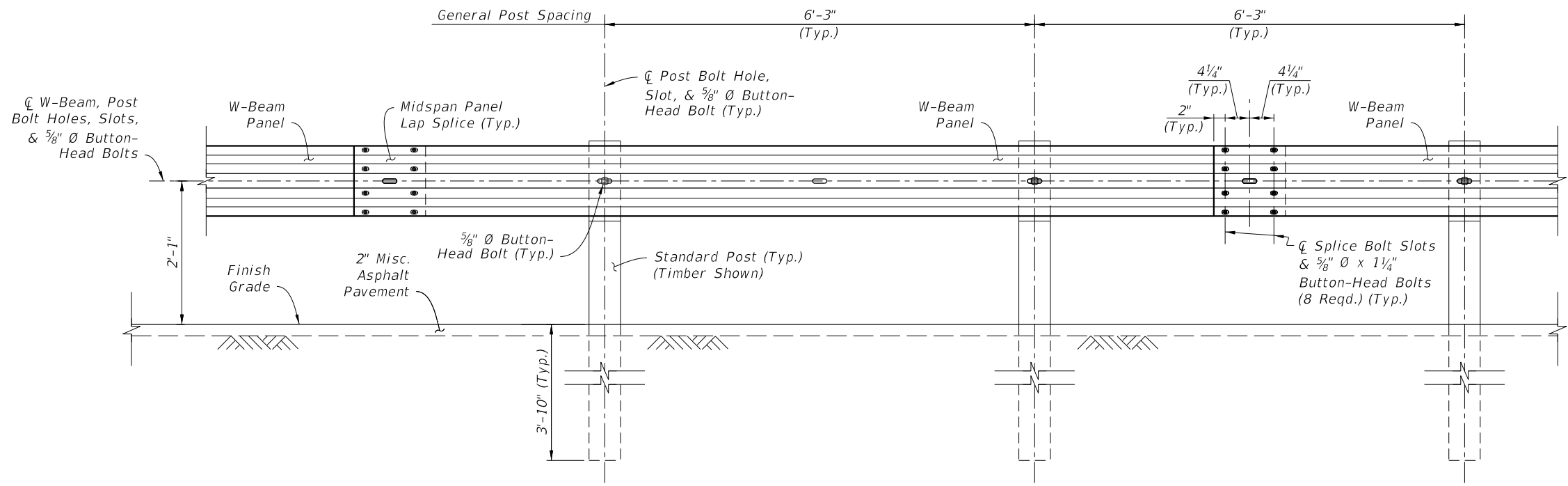

**GENERAL GUARDRAIL
INSTALLED ELEVATION**

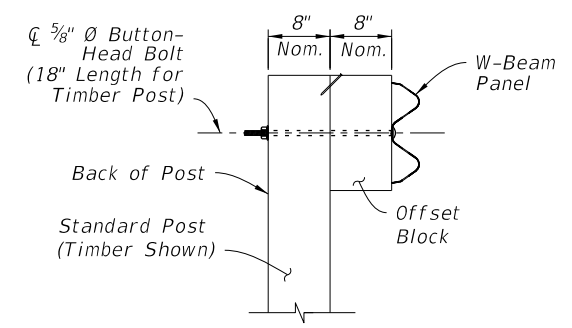

INSTALLED SECTION

NOTES:

- GENERAL:** Install the General Guardrail configuration where indicated in the plans. This may include tapered segments if called for in the plans.

Use 12'-6" or longer W-Beam Panels. A single 6'-3" Panel may be used at the end of the run to meet the nominal Begin/End Guardrail Sta. requirements.

Where a differing guardrail configuration is required for constructability beyond the options shown in this Index or the plans, obtain approval from the Engineer prior to installation.
- MIDSPAN PANEL LAP SPLICE:** For proper structural function, place all Lap Splices at midspan unless otherwise indicated.

Lap the Panels with the Splice Ridge oriented downstream of the final Direction of Traffic in the nearest traffic lane. For reverse lane conditions, orient the Splice Ridge downstream of the lane direction with the highest traffic volume. Orienting Lap Splices for Temporary Traffic Control phasing is not required.
- CONNECTION DETAILS:** Connections to End Treatments, Approach Transitions, or other segment types are defined in the following Index Sheets, APL Drawings, or the plans.
- W-BEAM PANEL DETAILS:** See Sheet 4.
- POST & OFFSET BLOCK DETAILS:** See Sheet 5.
- GUARDRAIL SECTIONS:** For Sections showing typical mounting heights, grading, and lateral offsets in relation to adjacent roadway features, see Sheet 6.
- MODIFIED MOUNTS:** Where concrete structures, concrete sidewalk, or shallow depth conditions are encountered, see Sheet 23 for additional post mounting options.
- DEFINED SEGMENTS:** The General Guardrail shown provides the base configuration, including Post Spacing and splice locations, for Defined Segment modifications where indicated in the plans and using the Guardrail Types, Sections, and/or hardware as shown in this Index (e.g. Double Faced W-Beam, Deep Posts at Slope Breaks, Pipe Rail, Rub Rail, or Reduced Post Spacing for Hazards).

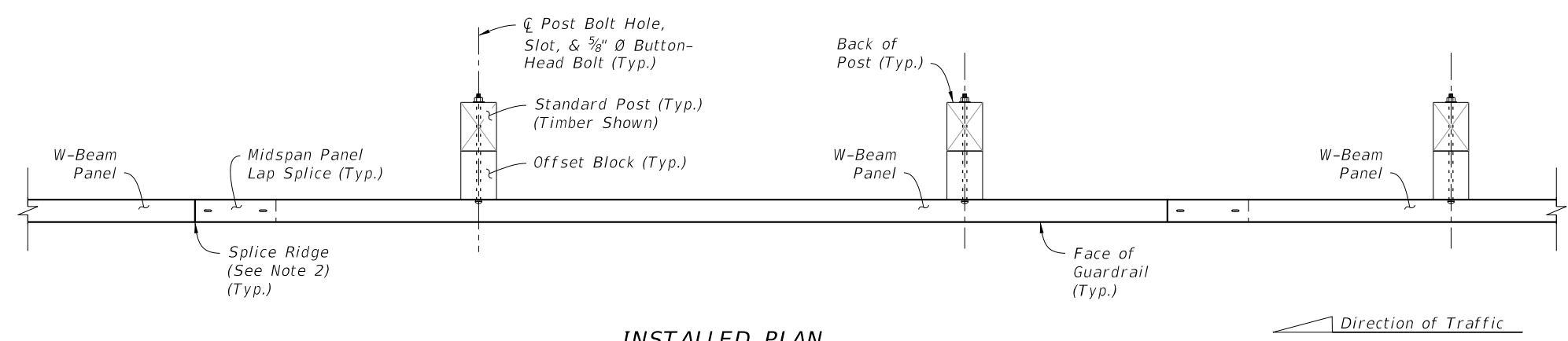

INSTALLED PLAN

GENERAL, TL-3 GUARDRAIL DETAILS

10/20/2022 8:53:02 AM

LAST REVISION 11/01/19	REVISION	DESCRIPTION:		FY 2023-24 STANDARD PLANS	GUARDRAIL	INDEX 536-001	SHEET 2 of 24
---------------------------	----------	--------------	--	------------------------------	-----------	------------------	------------------

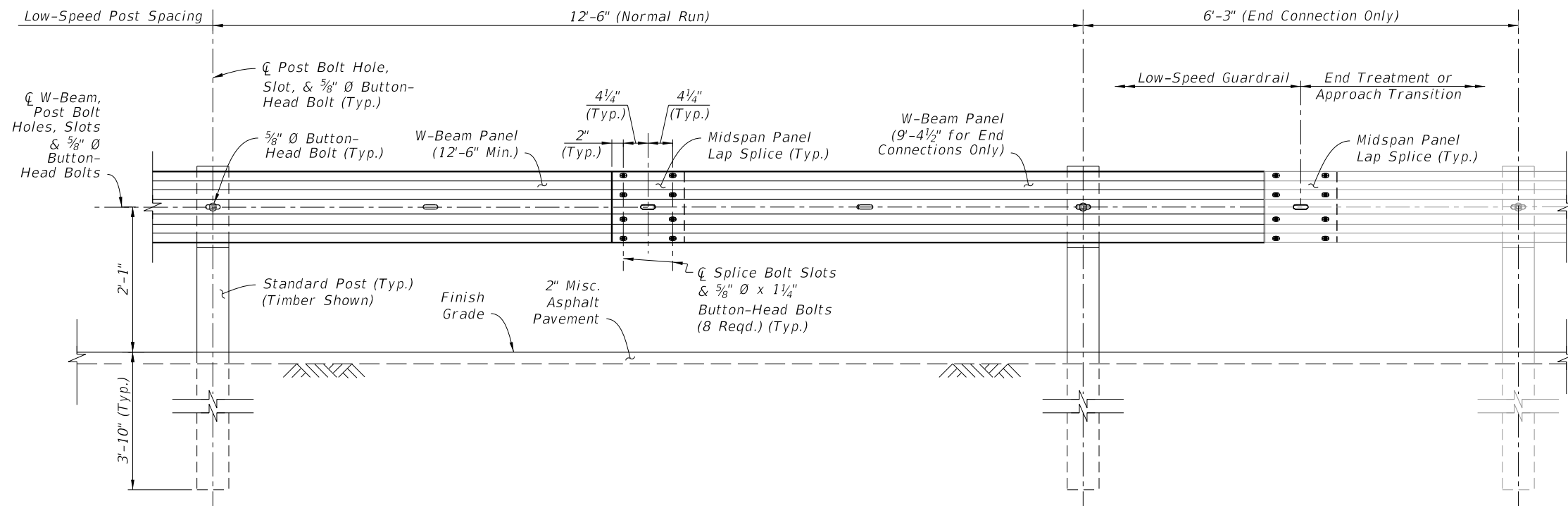

**LOW-SPEED GUARDRAIL
INSTALLED ELEVATION**

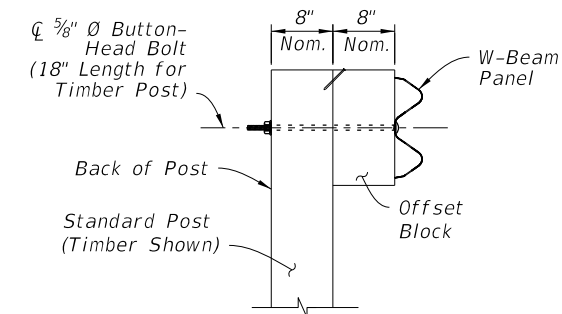

INSTALLED SECTION

NOTES:

1. **GENERAL:** Install the Low-Speed Guardrail configuration where indicated in the plans. Low-Speed Guardrail may include tapered segments if called for in the plans.

Use 12'-6" or 25'-0" W-Beam Panels for normal spans, and use 9'-4 1/2" Panels for end connections to adjoining segments as shown. A single 6'-3" Panel may be used at the end of the Low-Speed Guardrail run along with a single reduced 6'-3" post spacing to meet the nominal Begin/End Guardrail Sta. required.

Where a differing guardrail configuration is required for constructability beyond the options shown in this Index or the Plans, obtain approval from the Engineer prior to installation.

2. **MIDSPAN PANEL LAP SPLICE:** For proper structural function, place all Lap Splices at midspan unless otherwise indicated.

Lap the Panels with the Splice Ridge oriented downstream of the final Direction of Traffic in the nearest traffic lane. For reverse lane conditions, orient the Splice Ridge downstream of the lane direction with the highest traffic volume. Orienting Lap Splices for Temporary Traffic Control phasing is not required.

3. **CONNECTION DETAILS:** Connections to End Treatments, Approach Transitions, or other segment types are defined in the following Index Sheets, APL Drawings, or the plans.

4. **W-BEAM PANEL DETAILS:** See Sheet 4.

5. **POST & OFFSET BLOCK DETAILS:** See Sheet 5.

6. **GUARDRAIL SECTIONS:** For Sections showing typical mounting heights, grading, and lateral offsets in relation to adjacent roadway features, see Sheet 6.

7. **MODIFIED MOUNTS:** Where concrete structures, concrete sidewalk, or shallow depth conditions are encountered, see Sheet 23 for additional post mounting options.

8. **RESTRICTIONS:** Low-Speed Guardrail segments are not permitted for use with items including, but not limited to, Double Faced W-Beam, Deep Posts at Slope Breaks, Raised Curb, Pipe Rail, and/or Rub Rail.

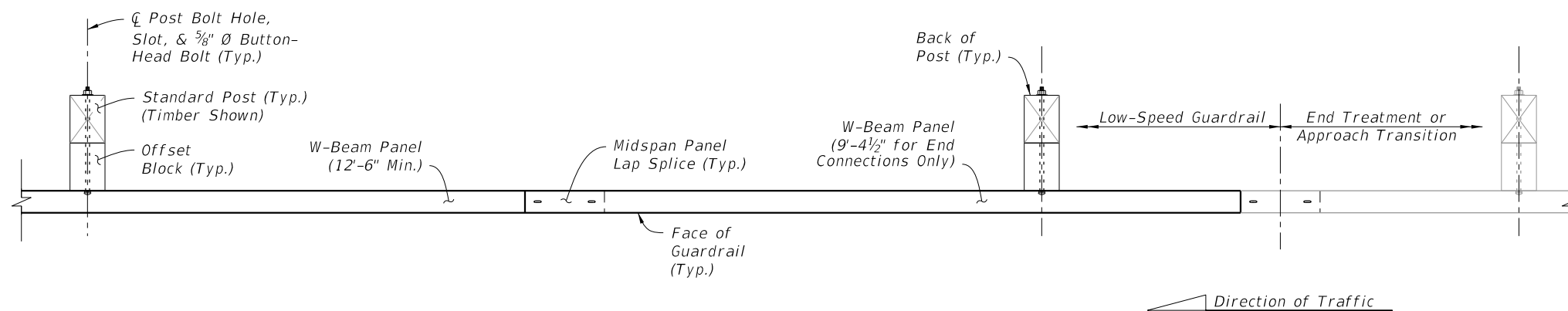

INSTALLED PLAN

LOW-SPEED, TL-2 GUARDRAIL DETAILS

10/20/2022 8:53:03 AM

LAST REVISION 11/01/19	REVISION	DESCRIPTION:	 FY 2023-24 STANDARD PLANS	GUARDRAIL	INDEX 536-001	SHEET 3 of 24
---------------------------	----------	--------------	---	------------------	------------------	------------------

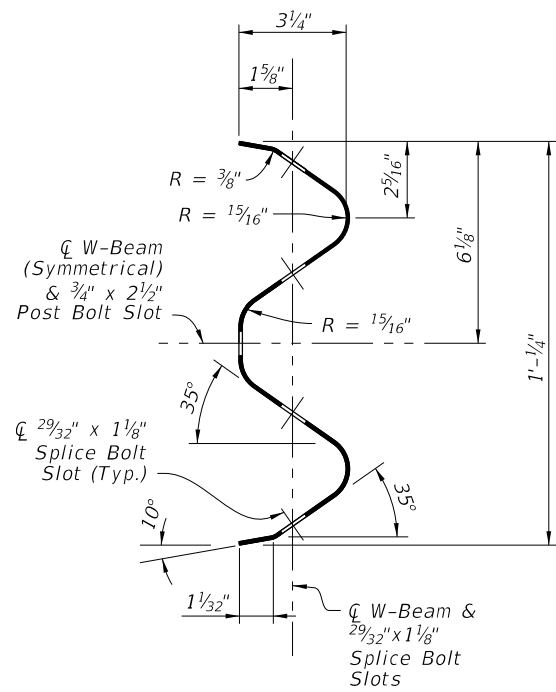

W-BEAM PANEL SECTION

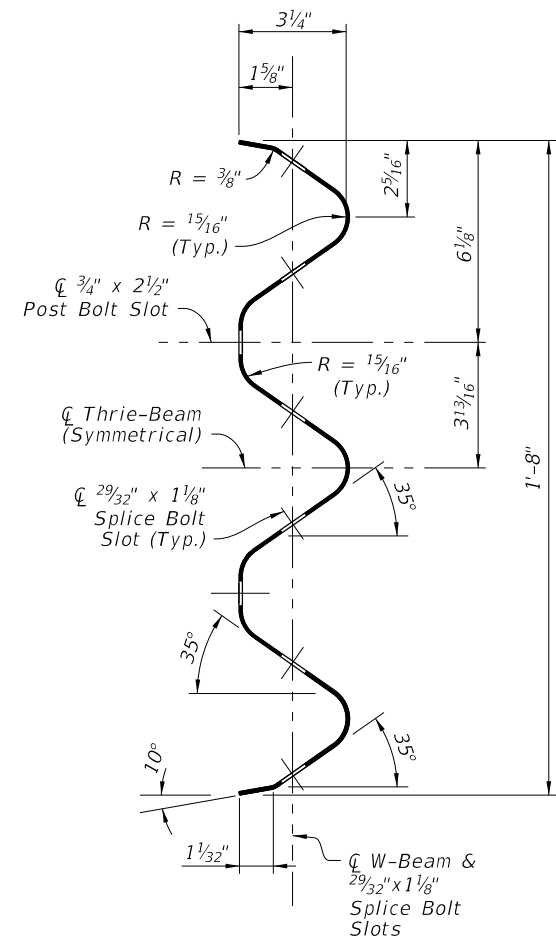

THRIE-BEAM PANEL SECTION

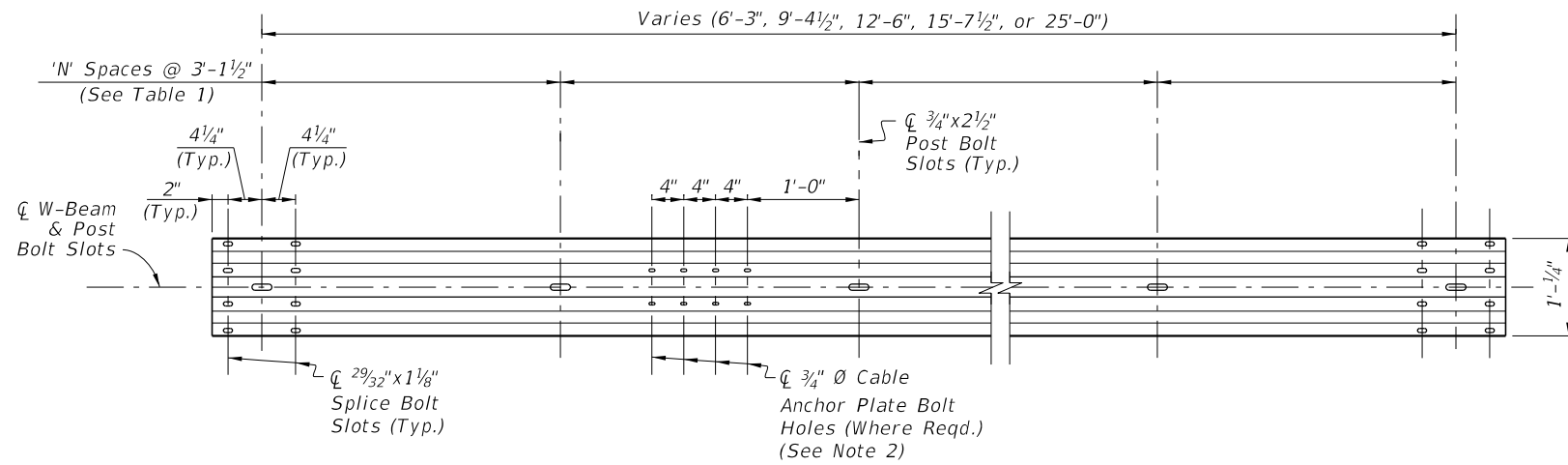

W-BEAM PANEL ELEVATION

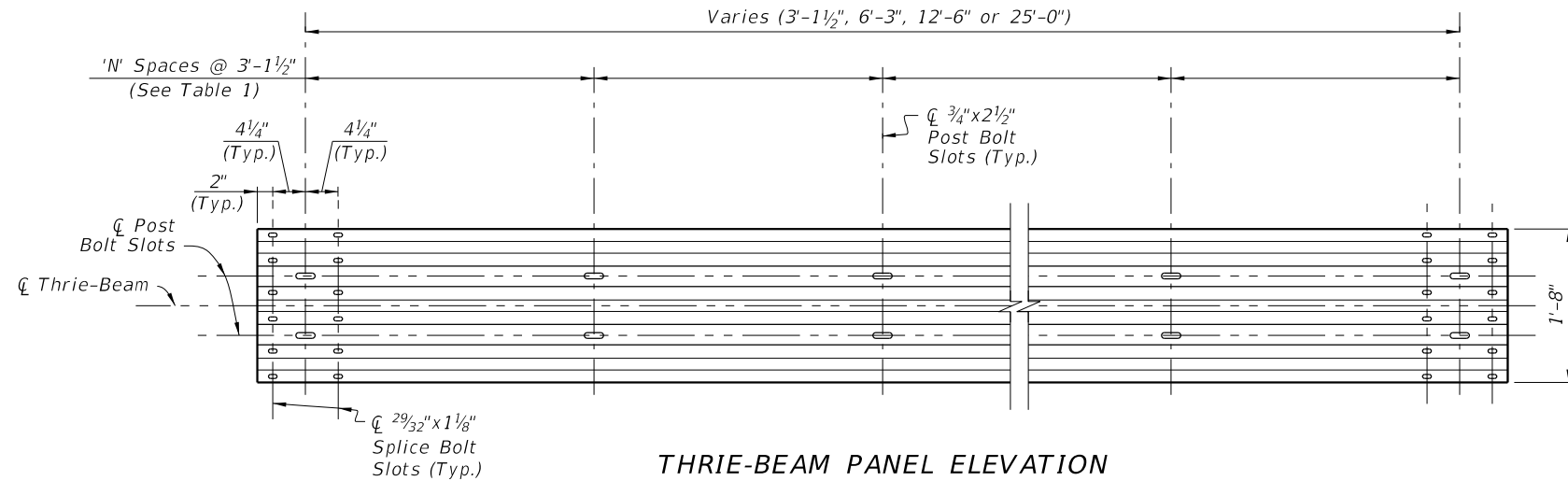

THRIE-BEAM PANEL ELEVATION

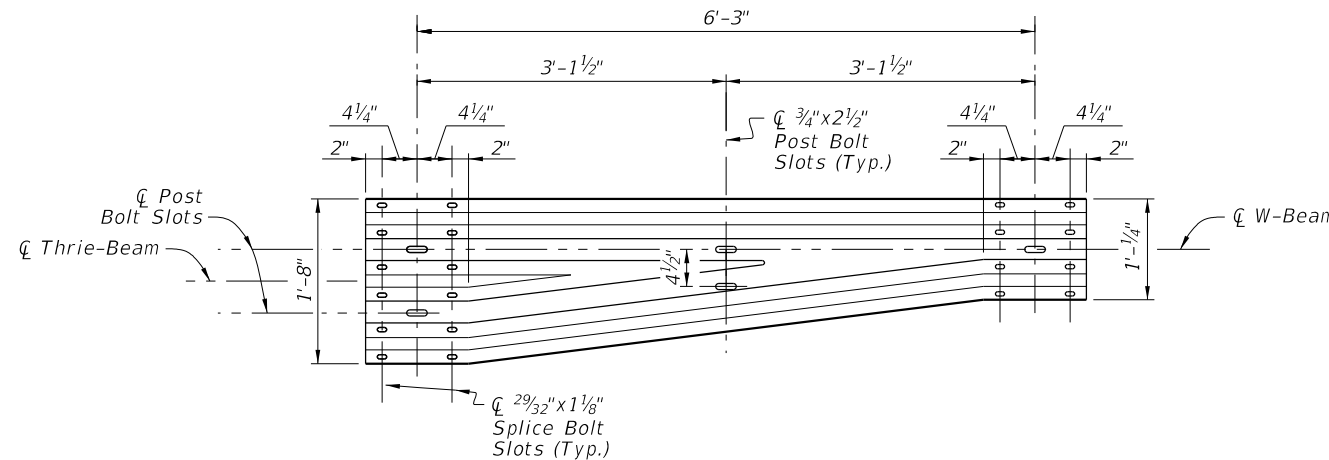

THRIE-BEAM TRANSITION PANEL ELEVATION
(Reverse Direction Similar by Opposite Hand)

PANEL SUMMARY TABLE:

Panel Type	Number of Spaces 'N'	Gauge
6'-3" W-Beam	2	12
9'-4 1/2" W-Beam	3	12
12'-6" W-Beam	4	12
15'-7 1/2" W-Beam	5	12
25'-0" W-Beam	8	12
3'-1 1/2" Thrie-Beam	1	10
6'-3" Thrie-Beam	2	12
12'-6" Thrie-Beam	4	12
25'-0" Thrie-Beam	8	12
Thrie-Beam Trans.	2	10

NOTES:

- MATERIALS:**
Use corrugated steel panels in accordance with Specification 967 and made from either Class A, 12 gauge steel or Class B, 10 gauge steel as specified in the 'Panel Summary Table' above.
- CABLE ANCHOR PLATE BOLT HOLES:**
Include 3/4 inch \emptyset Cable Anchor Plate Bolt Holes only where required for installation of the Cable Anchor Plate shown on Sheet 9, 10, & 11.

29/32 inch x 1 1/8 inch slots may substitute for the 3/4 inch \emptyset holes shown.

10/20/2022 8:53:04 AM

LAST REVISION 11/01/19	DESCRIPTION:
---------------------------	--------------

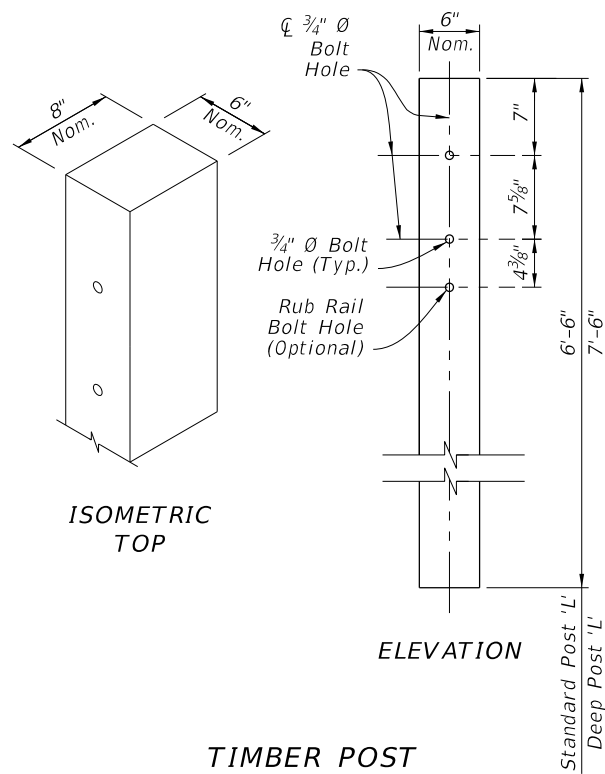

TIMBER POST
(6"X8" Nominal)

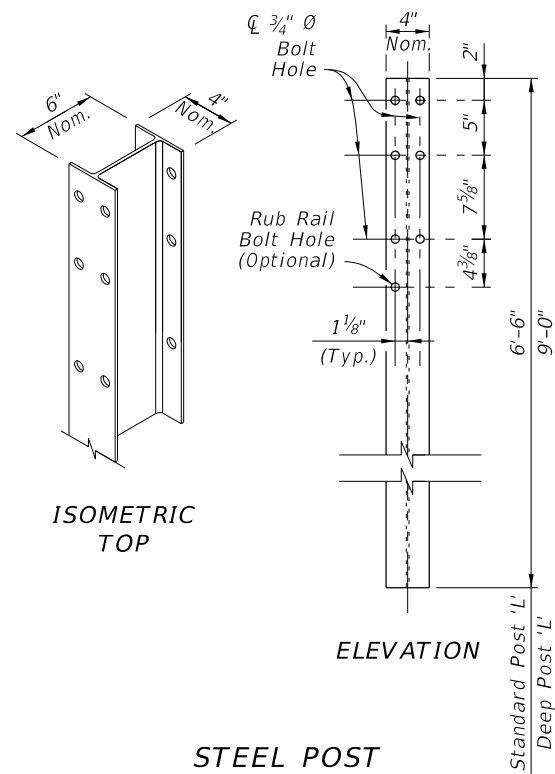

STEEL POST
(W6X8.5 or W6X9)

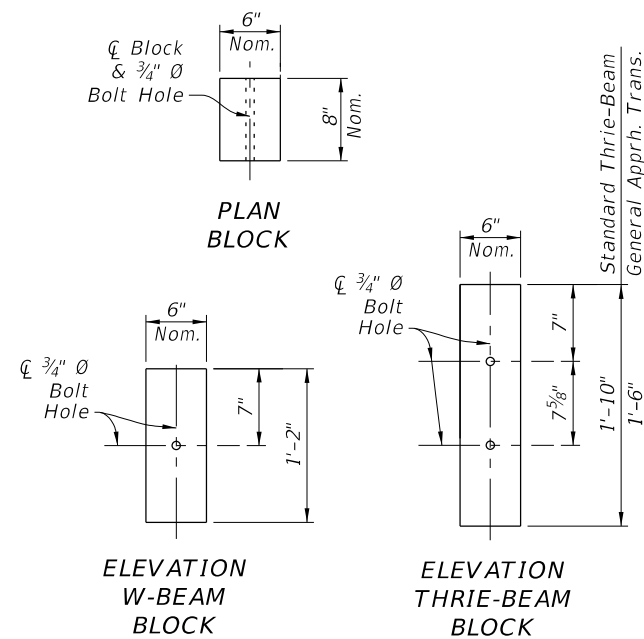

TIMBER OFFSET BLOCK
(6"X8" Nominal)

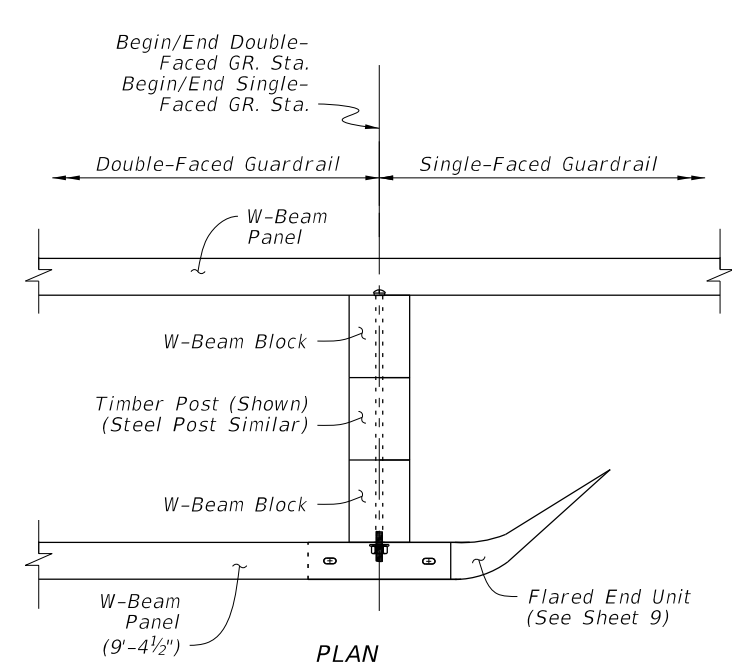

SINGLE-FACED / DOUBLE-FACED
GUARDRAIL CONNECTION

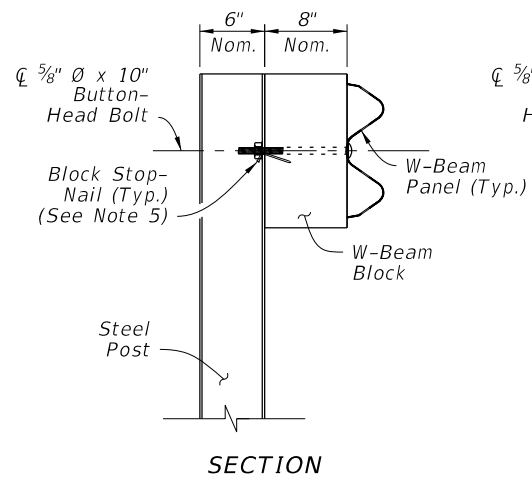

SECTION

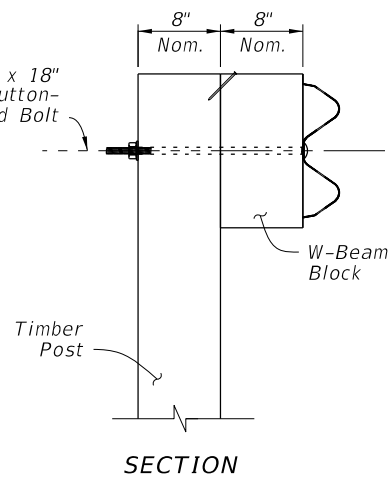

SECTION

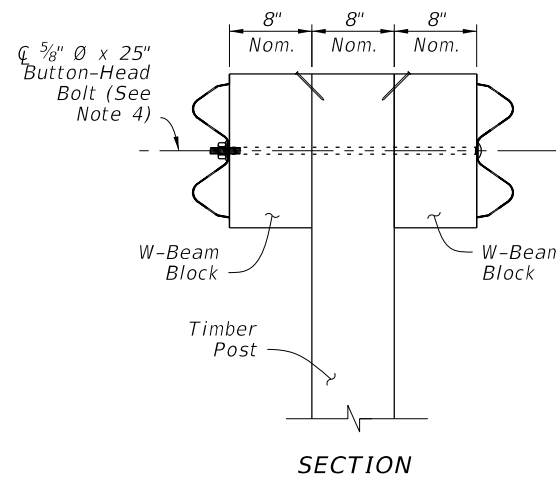

SECTION

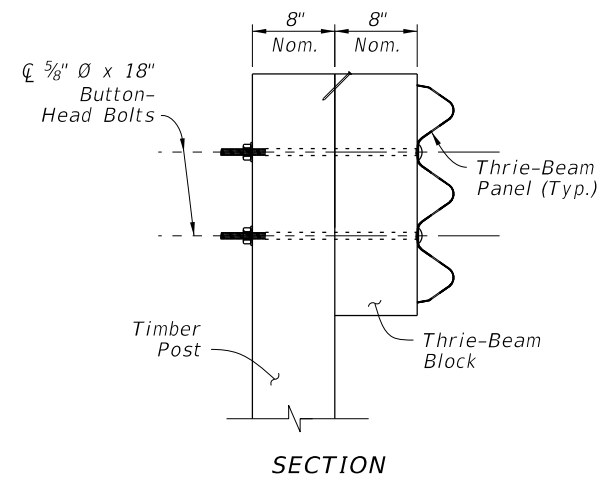

SECTION

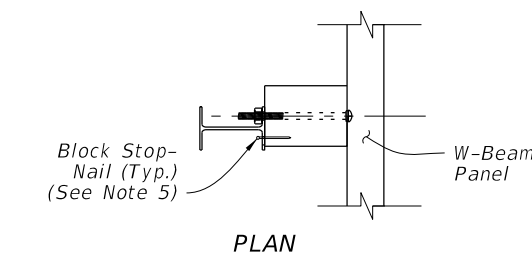

PLAN

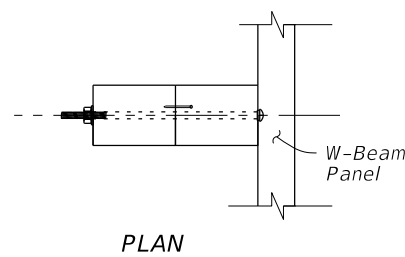

PLAN

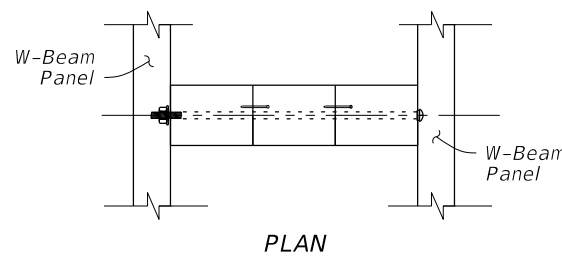

PLAN

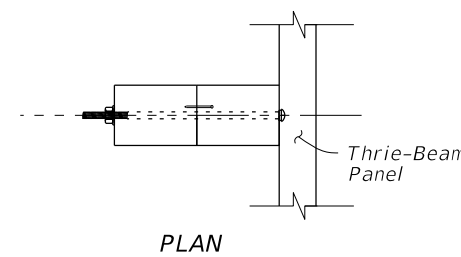

PLAN

SINGLE-FACED
W-BEAM
STEEL POST

SINGLE-FACED
W-BEAM
TIMBER POST

DOUBLE-FACED W-BEAM
TIMBER POST
(Thrie-Beam Similar)
(Steel Post Similar)

THRIE-BEAM
TIMBER POST
(Steel Post Similar)

NOTES:

- STANDARD POSTS:** Where Standard Posts are called for in this Index, use either a Timber Post or Steel Post at the Length, 'L', shown for Standard Posts. Use a single post material type consistently per each run of guardrail. Only where specified in the Plans, use the Deep Post 'L' for Slope Break Conditions as shown on Sheet 6.
- OFFSET BLOCKS:** For each Panel type, install the corresponding Offset Block type as shown. For General, TL-3 (Single Faced) Approach Transitions only, use the 1'-6" Thrie-Beam Block (See Sheet 13).
- BOLT HOLES:** 3/4" Ø Bolt Holes shown in posts within this Index may be substituted with 1 3/16" Ø Bolt Holes.
- DOUBLE FACED GUARDRAIL:** Orient Post Bolts with the Button-Head located on the side nearest the traffic lane. The bolt's threaded portion is not permitted to extend beyond 3/4" from the face of the tightened nut; trim the threaded portion as needed and galvanize in accordance with Specification 562.
- BLOCK STOP-NAIL:** Drive one nail per Standard Offset Block as shown to prevent Block rotation. Use steel 3 1/2" Type 16d nails with ASTM A153 hot-dip galvanization. For steel posts, drive the nail through the unused flange Bolt Hole and bend the nail so its head contacts the flange.
- MATERIALS:** Use timber and steel posts and offset blocks in accordance with Specification 967. Composite offset blocks may be substituted as approved on the APL. Use a single offset block type consistently per each run of guardrail. Steel offset blocks are only permitted For Modified Thrie Beam.

POST AND OFFSET BLOCK DETAILS

10/20/2022 8:53:05 AM

LAST REVISION 11/01/19	REVISION	DESCRIPTION:	 FY 2023-24 STANDARD PLANS	GUARDRAIL	INDEX 536-001	SHEET 5 of 24
---------------------------	----------	--------------	--	------------------	------------------	------------------

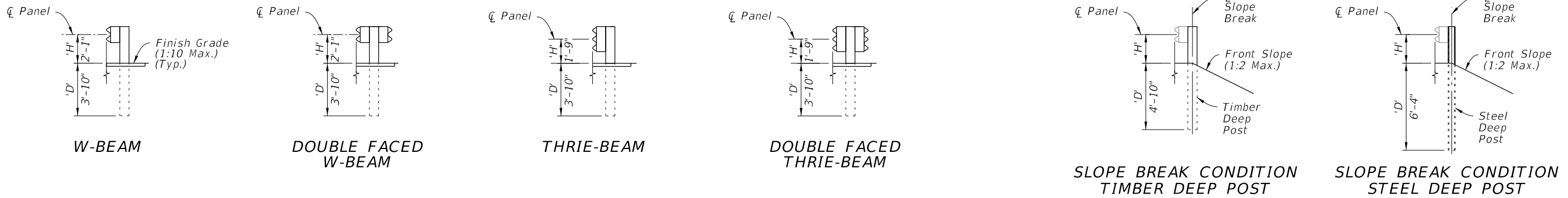

GUARDRAIL TYPES - MOUNTING HEIGHTS & POST DEPTHS

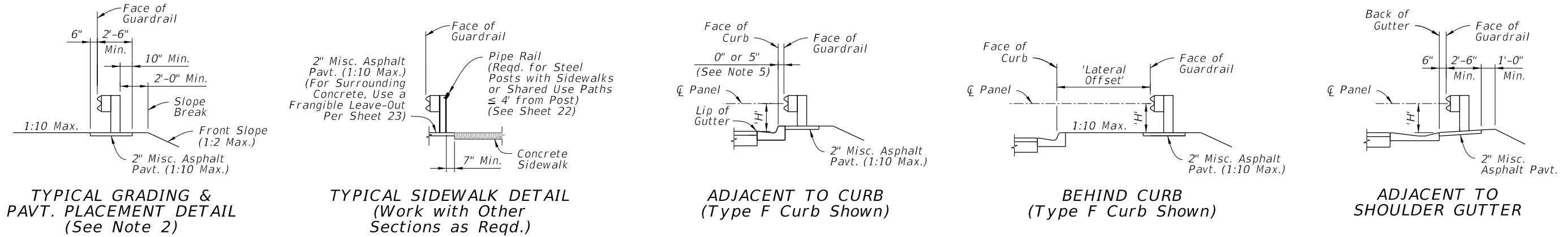

GUARDRAIL SECTIONS - TYPICAL

GUARDRAIL SECTIONS - CURB & GUTTER

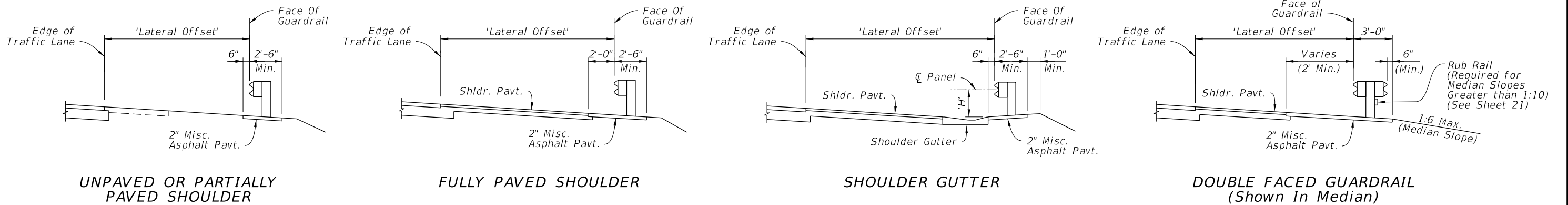

GUARDRAIL SECTIONS - SHOULDERS

GUARDRAIL HEIGHT SUMMARY TABLE:			
Type:	Min. Depth 'D':	Mounting Height 'H':	Post Length 'L':
W-Beam (Single and Double Faced)	3'-10"	2'-1"	6'-6"
Thrie-Beam (Single and Double Faced)	3'-10"	1'-9"	6'-6"
Timber Deep Post	4'-10"	See Above	7'-6"
Steel Deep Post	6'-4"	See Above	9'-0"

NOTES:

- GUARDRAIL SECTIONS: Construct Sections as indicated in the plans. The details shown herein depict W-Beam Guardrail, but are applicable to the other defined Guardrail Types placed at the corresponding height, 'H'. Use components per Sheets 4 & 5. Steel and timber post types are interchangeable unless otherwise defined. The 1:10 Max. cross slope shown is the maximum slope permitted for proper guardrail function, but project-specific cross slope requirements are governed by additional design criteria, per the plans.
- TYPICAL GRADING & PAVEMENT PLACEMENT DETAIL: Construct features as depicted except where superseded by specific Guardrail Sections or the plans. Place the Slope Break a Minimum of 2' behind the post. For Deep Posts, the slope break may be placed at the \bar{C} Post with the 2" Miscellaneous Asphalt Pavement omitted.
- SLOPE BREAK CONDITION: Install Deep Posts only where called for in the plans. Deep Posts are only permitted where post spacing is 6'-3" or less.
- LATERAL OFFSETS: The Lateral Offsets shown are governed by the station and offset call outs for Face of Guardrail, as shown in the plans.
- ADJACENT TO CURB: Place the Face of Guardrail consistently offset either flush with the Face of Curb or 5" behind the Face of Curb, as indicated by the plans station and offset callout. For offset changes, transition the Face of Guardrail as shown in the plans.

GUARDRAIL SECTIONS

10/20/2022 8:53:06 AM

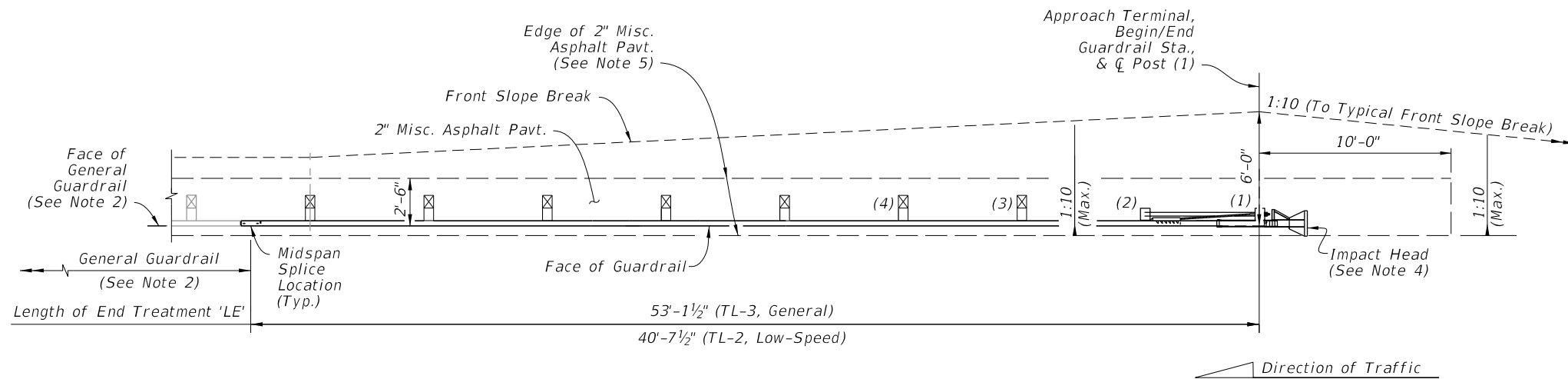

**APPROACH TERMINAL ASSEMBLY
'PARALLEL' TYPE - PLAN VIEW**

NOTES:

1. **INSTALLATION:** Locate Approach Terminals where called for in the plans, with the Post (1) placed at the Begin/End Guardrail Station indicated in the plans.

The Plan Views shown herein are schematic only, showing basic geometry for Approach Terminals listed on the APL. The predefined Length of End Treatment, 'LE', includes the proprietary portion of various Approach Terminals and provides for more consistent planning of assembly installations across the differing Approach Terminal types. Forward-anchoring style Approach Terminals may vary from the planned lengths shown by up to 3'-0".

Construct Approach Terminals as shown in the APL and in accordance with the manufacturer's unique drawing details, procedures, and specifications.

Install posts in accordance with the manufacturer's drawings. The Special Posts on Sheet 23, including Special Steel Posts, Encased Posts, and Frangible Leave-Outs, are not permitted within the Approach Terminal segment unless otherwise called for in the plans.

Align panel lap splices in accordance with the manufacturer's drawings, regardless of the direction of traffic.

Install adjacent grading, gutters, and/or curbing as shown herein.

2. **GENERAL GUARDRAIL:** General Guardrail typically includes Panels and Post Spacing as shown on Sheet 2, including parallel and tapered segments.

Approach Transitions, Low-Speed Guardrail, or Reduced Post Spacing Guardrail segments may be substituted for the General Guardrail shown herein if indicated in the plans.

3. **APPROACH TERMINAL TEST LEVEL:** Install either a Test Level 3 (TL-3) or Test Level 2 (TL-2) Approach Terminal as specified in the plans. TL-3 Approach Terminals may substitute for TL-2 Approach Terminals unless the substitution is specifically prohibited in the plans. TL-2 Approach Terminals may not substitute for TL-3 installations.

4. **IMPACT HEAD END DELINEATOR:** Apply Yellow Retroreflective Sheeting to the nose of the End Terminal in accordance with Specification 536.

5. **2" MISCELLANEOUS ASPHALT PAVEMENT:** The Plan View depicts the Unpaved Shoulder condition. For Fully Paved Shoulder and Shoulder Gutter conditions, extend the 2" Misc. Asphalt Pavement as shown in the corresponding 'Section at Post (1)' details below.

The 2" Misc. Asphalt Pavement shown upstream of Post (1) may be substituted with a different pavement type where called for in the Plans.

6. **CLEAR AREA REQUIREMENT:** Do not place any permanent aboveground installations within the areas shown with 1:10 maximum grading. For the finished condition, keep this area free of all aboveground obstructions, including dense vegetation and trees.

7. **'CURBED' AND 'DOUBLE FACED' GUARDRAIL SEGMENTS:** See Sheet 8.

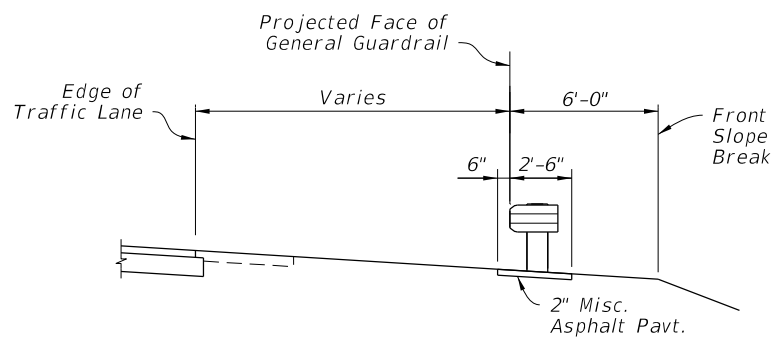

**SECTION AT POST (1)
WITH UNPAVED SHOULDER**

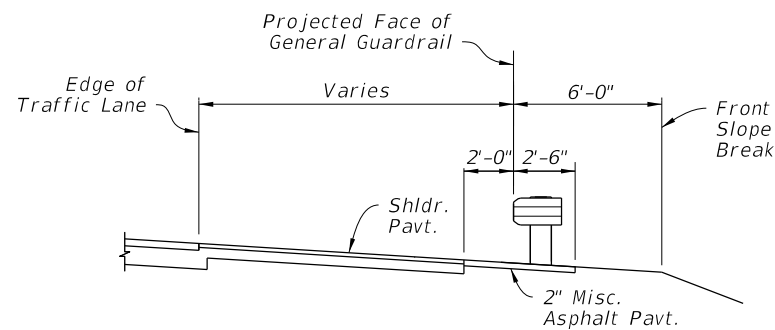

**SECTION AT POST (1)
WITH FULLY PAVED SHOULDER**

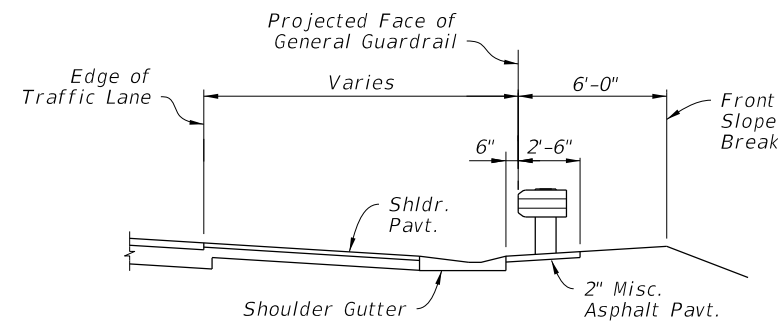

**SECTION AT POST (1)
WITH SHOULDER GUTTER**

END TREATMENT - APPROACH TERMINAL GEOMETRY - PARALLEL

10/20/2022 8:53:07 AM

LAST REVISION 11/01/20	REVISION	DESCRIPTION:		FY 2023-24 STANDARD PLANS	GUARDRAIL	INDEX	SHEET
						536-001	7 of 24

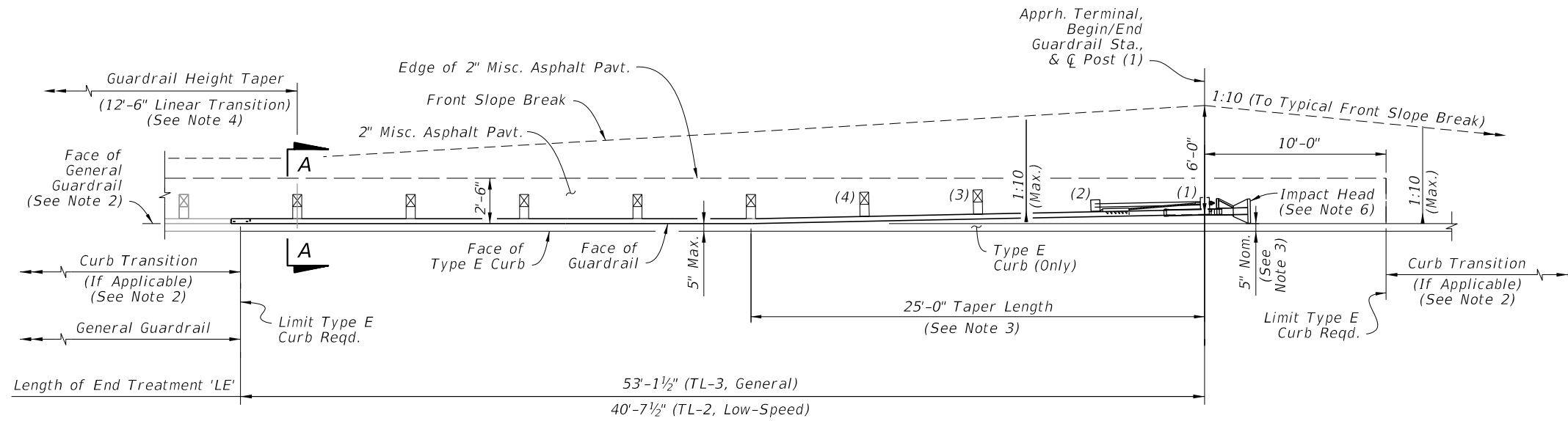

**APPROACH TERMINAL ASSEMBLY
'CURBED' SEGMENT - PLAN VIEW**

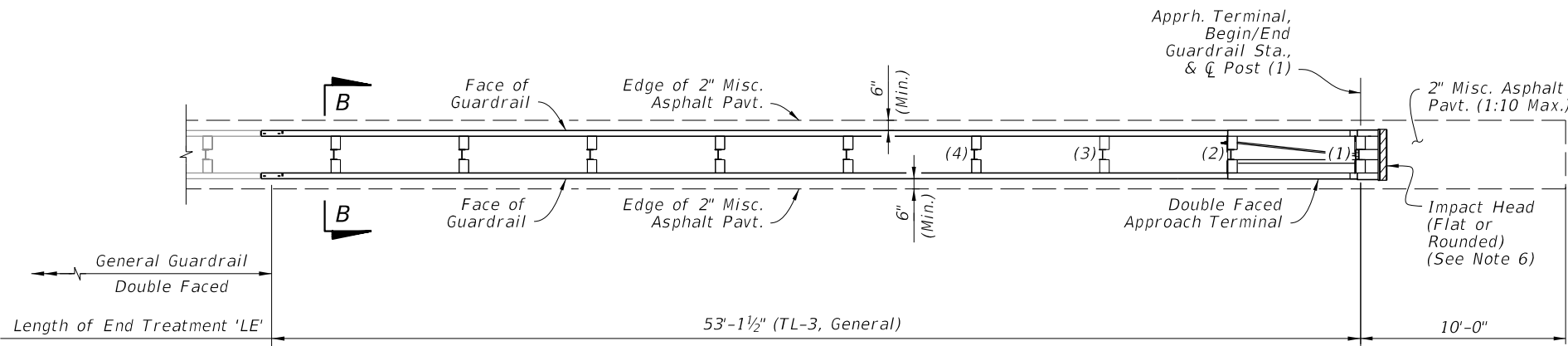

**APPROACH TERMINAL ASSEMBLY
'DOUBLE FACED' SEGMENT - PLAN VIEW**

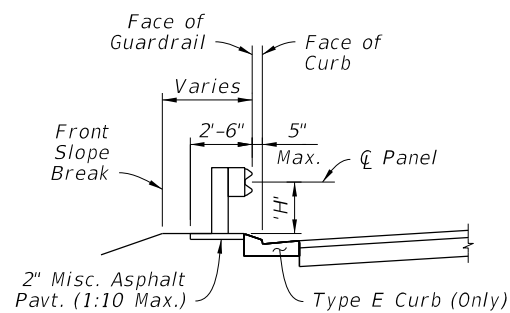

'CURBED' SECTION A-A
(Height, 'H', Measured from
Misc. Asphalt Pavt.)

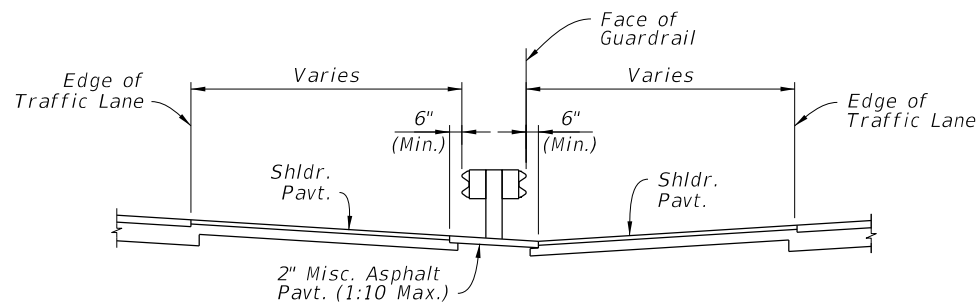

'DOUBLE FACED' SECTION B-B
(1:10 Slope or Flatter Reqd.)

NOTES:

1. GENERAL: See Notes 1 through 3 on Sheet 7.
2. CURBED SEGMENTS: Type E curb is required within the limits shown. When a different curb type is called for outside of the Type E curb limits, transition the curb shape linearly, over a nominal distance ranging 5'-0" to 10'-0"
3. TAPER LENGTH: For Curbed Segments, taper the guardrail away from the roadway where shown to place the inside edge of the Impact Head at 5" behind the face of the curb. Where additional lateral offset is required to fit the Approach Terminal Assembly hardware, such as a soil plate, place the Impact Head as close to the curb as the hardware allows, not to exceed 2'-0" from the face of curb.
4. GUARDRAIL HEIGHT TAPER: For Curbed Segments, the connecting General Guardrail Mounting Height, 'H', is typically measured from the Lip of Gutter (See Sheet 6 Guardrail Sections, 'Adjacent to Curb'), while the End Terminal Assembly 'H' is measured from the Misc. Asphalt Pavt. (See Section A-A). Linearly taper the difference in Mounting Height over a minimum length of 12'-6", starting where indicated herein.
5. DOUBLE FACED SEGMENT: Connect to Double Faced General Guardrail. Use consistent Posts and Offset Block types as specified in the APL drawings over the entire Length of End Treatment, 'LE'. Posts and Offset Blocks in the adjoining General Guardrail segment may be different from those inside of the 'LE'. A change in post type between timber and steel is permitted, immediately outside of the 'LE' segment.

Maintain the 1:10 maximum grading as shown in Section B-B throughout segment 'LE'. Where required, transition to differing adjacent slopes linearly, over a minimum longitudinal length of 25'-0".
6. IMPACT HEAD END DELINEATOR: Apply Yellow Retroreflective Sheeting to the nose of the End Terminal in accordance with Specification 536.
7. CLEAR AREA REQUIREMENT: Do not place any permanent aboveground installations within the areas shown with 1:10 maximum grading. For the finished condition, keep this area free of all aboveground obstructions, including dense vegetation and trees.
8. 2" MISCELLANEOUS ASPHALT PAVEMENT: The 2" Misc. Asphalt Pavement shown upstream of Post (1) may be substituted with a different pavement type where called for in the Plans.
9. SINGLE FACED 'PARALLEL' SEGMENTS: See Sheet 7.

END TREATMENT - APPROACH TERMINAL GEOMETRY CURBED AND DOUBLE FACED

10/20/2022 8:53:08 AM

LAST REVISION 11/01/19	DESCRIPTION:		FY 2023-24 STANDARD PLANS	GUARDRAIL	INDEX	SHEET
			536-001		8 of 24	

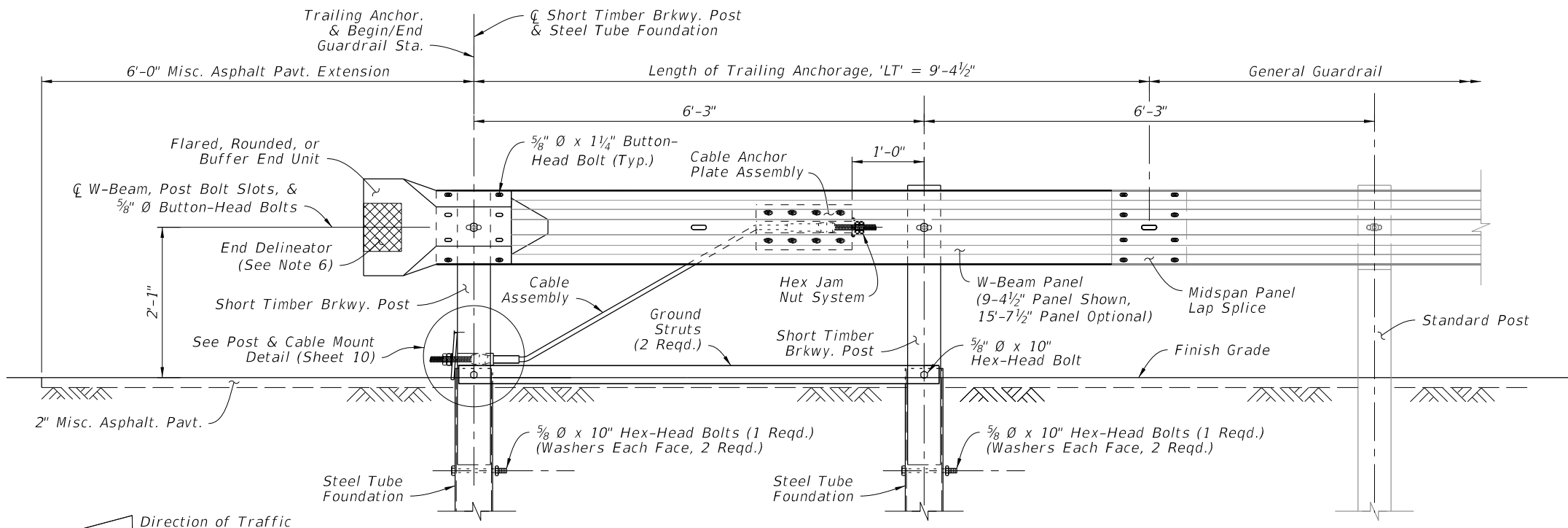

INSTALLED ELEVATION

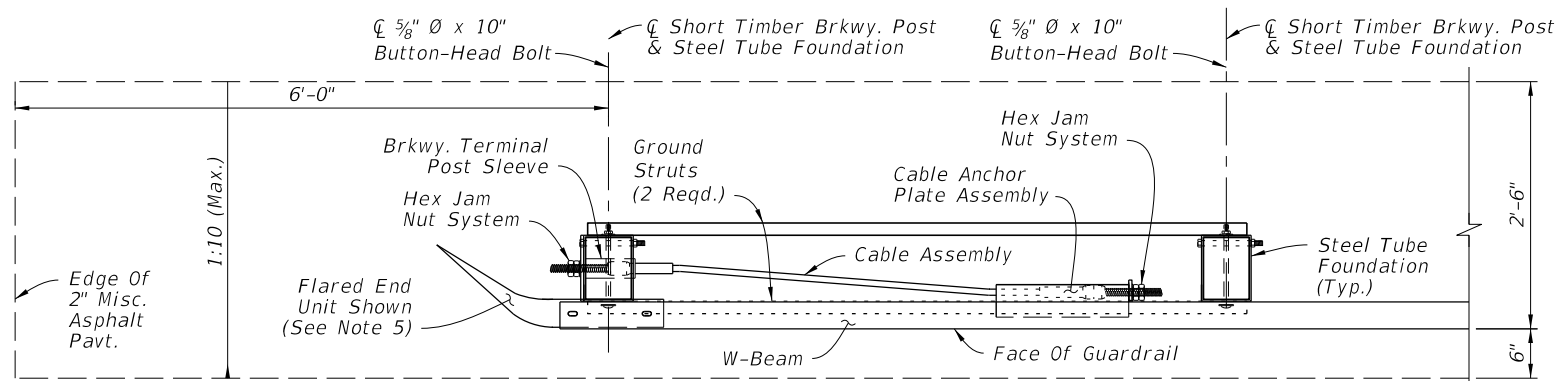

SINGLE FACE TRAILING ANCHORAGE
INSTALLED PLAN

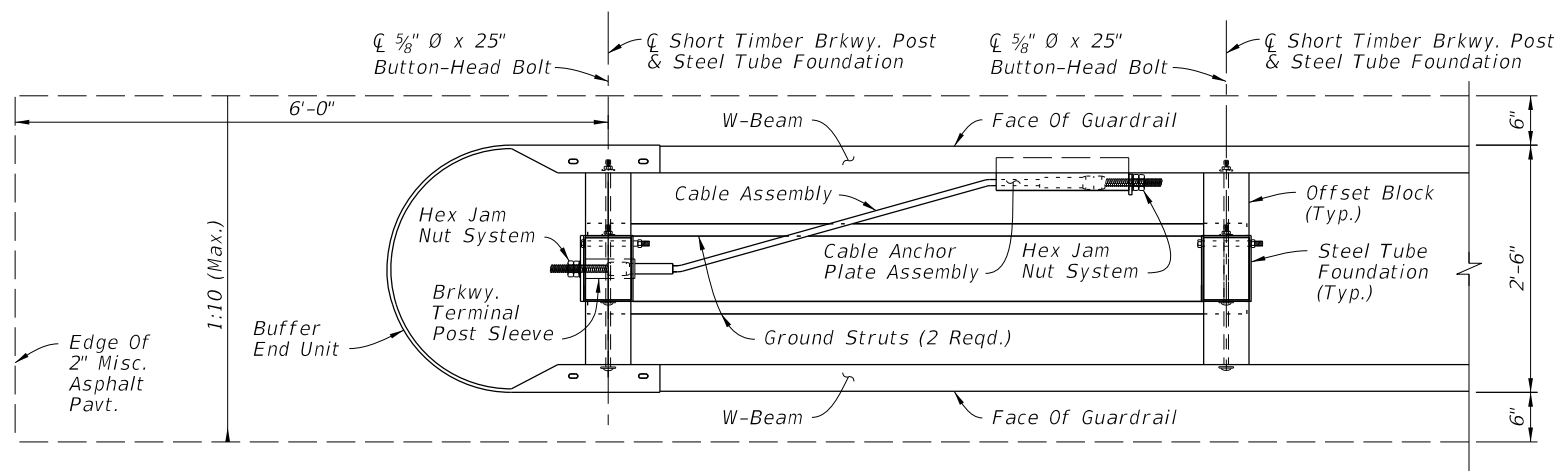

DOUBLE FACE TRAILING ANCHORAGE
INSTALLED PLAN

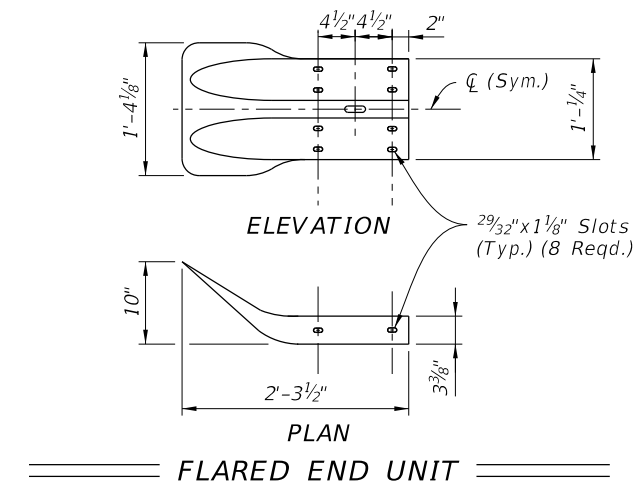

FLARED END UNIT

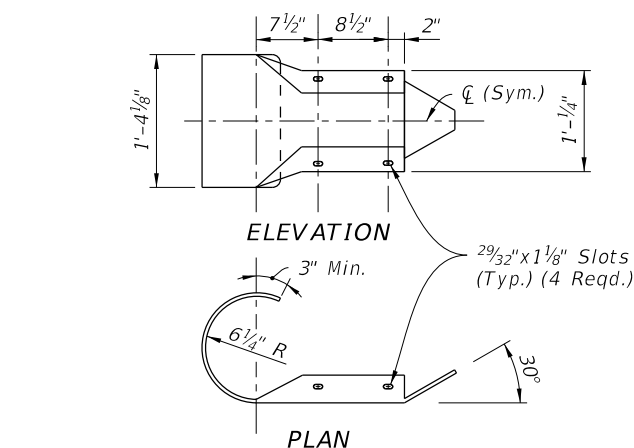

ROUNDED END UNIT

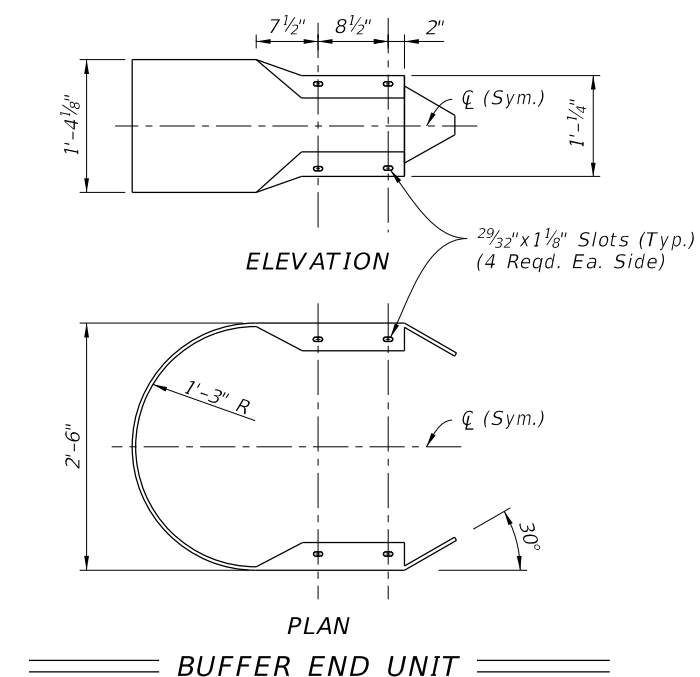

BUFFER END UNIT

NOTES:

- COMPONENT DETAILS: For additional component details, See Sheet 10.
- END UNITS: Use materials for end units as defined in Specifications Section 967. End Units are referred to as "End or Buffer Sections" in AASHTO M180.
Lap the Flared End Unit behind the W-Beam; lap the Rounded and Buffered End Units over the face of the W-Beam.
- FOUNDATIONS: Install Steel Tubes by either of the following methods:
 - Excavate, backfill, and compact material to provide full passive soil resistance to the surface of the Tube.
 - Drive the Tube using a dummy timber post to prevent damage to the Breakaway Post.
- GENERAL GUARDRAIL: General Guardrail typically includes Panels and Post Spacing as shown on Sheet 2, including parallel and tapered segments. Transitions, Low-Speed Guardrail, or Reduced Post Spacing Guardrail segments may be substituted for the General Guardrail shown herein if indicated in the plans.
- SIDEWALK REQUIREMENTS: When sidewalks are located adjacent to the End Treatment, install a Rounded End Unit (Flared End Unit not permitted for this case).
- END DELINEATOR: Mount retroreflective sheeting to the approach face of the End Unit in accordance with Specification Sections 536 and 967.

END TREATMENT - TRAILING ANCHORAGE

10/20/2022 8:53:09 AM

LAST REVISION 11/01/20	DESCRIPTION:		FY 2023-24 STANDARD PLANS	GUARDRAIL	INDEX	SHEET
			536-001		9 of 24	

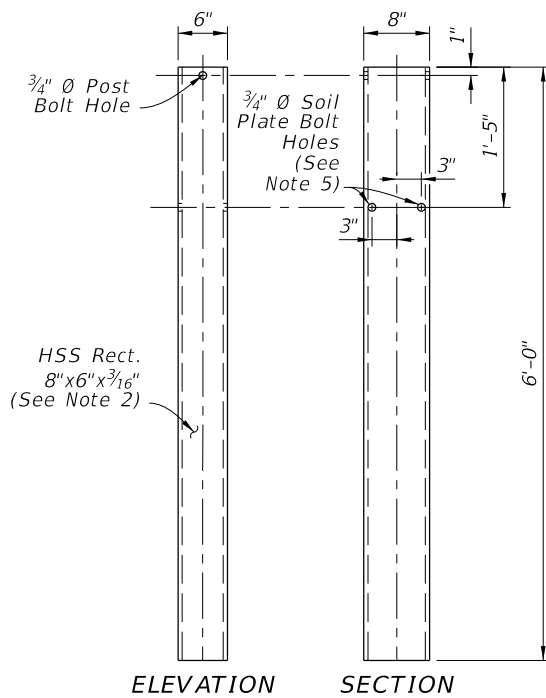

STEEL TUBE FOUNDATION

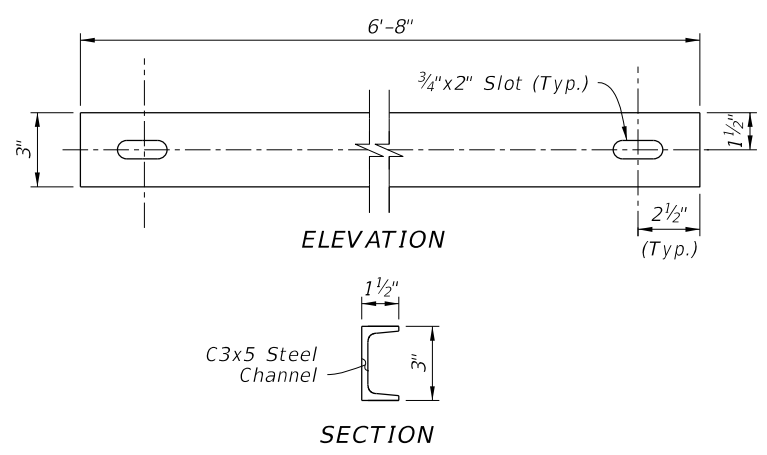

GROUND STRUT

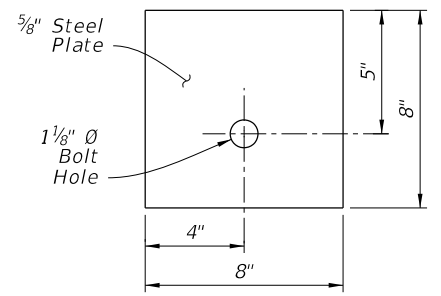

BEARING PLATE

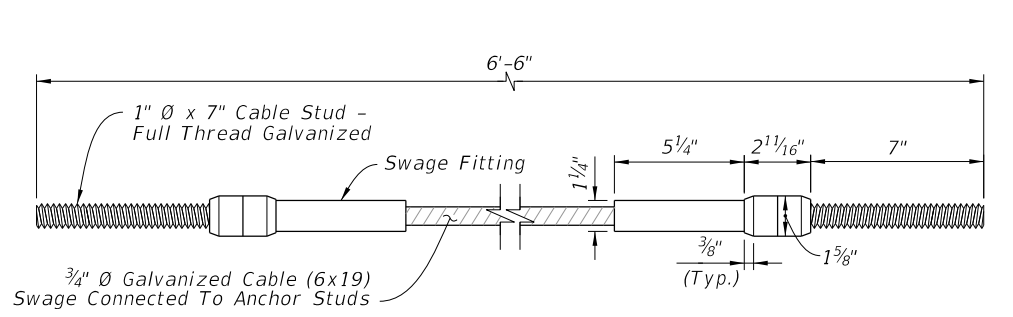

CABLE ASSEMBLY

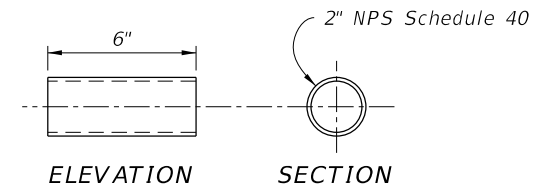

BREAKAWAY TERMINAL POST SLEEVE

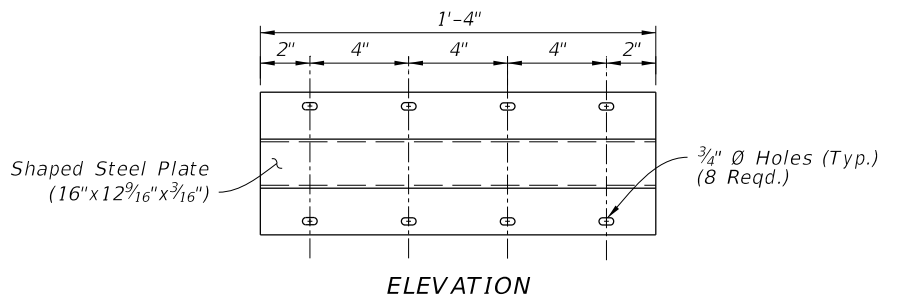

CABLE ANCHOR PLATE

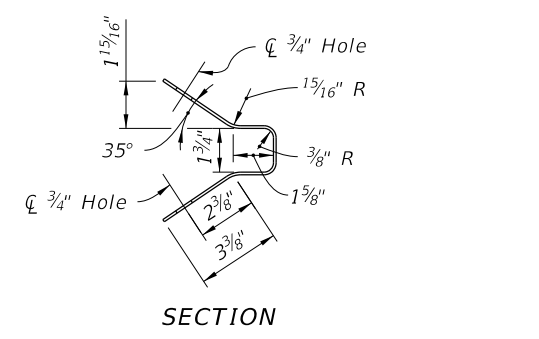

SECTION

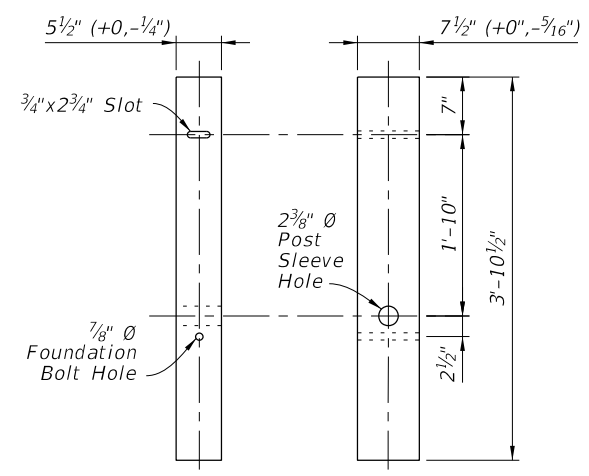

SHORT TIMBER BREAKAWAY POST (6"x8" Nom.)

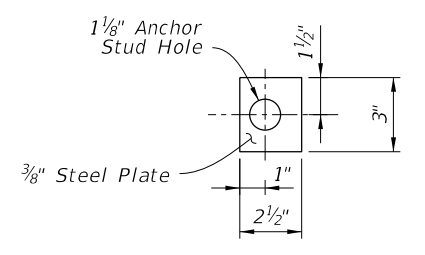

STEEL END PLATE

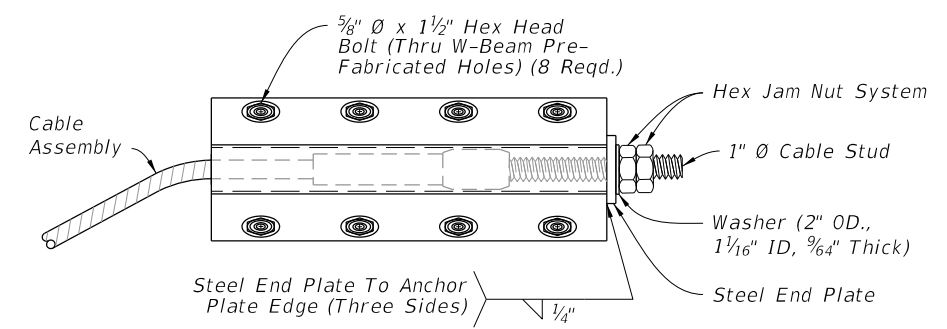

CABLE ANCHOR PLATE ASSEMBLY

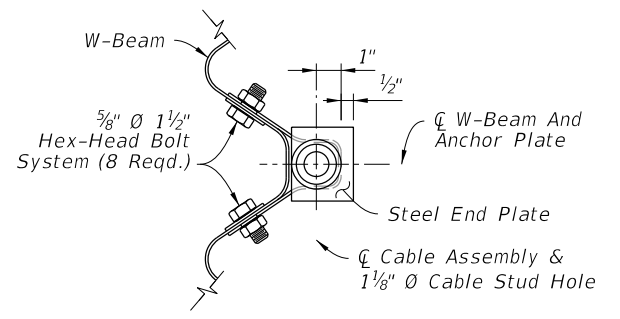

SECTION

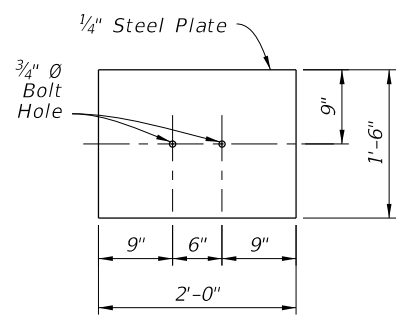

SOIL PLATE

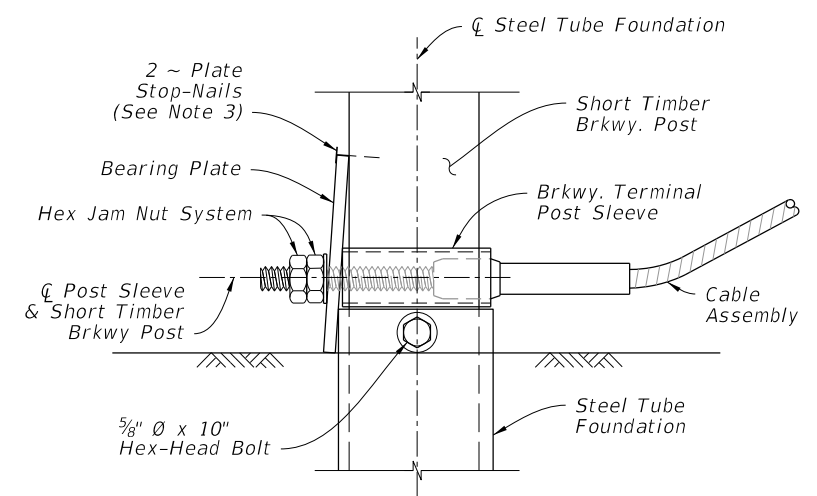

POST & CABLE MOUNT ASSEMBLY

NOTES:

- INSTALLATION: Use components as shown on Sheets 9 & 11.
- MATERIALS: Use steel plates, channels, and Cable Assemblies in accordance with Specification 967. Use Short Timber Breakaway Posts and Steel Tube Foundations in accordance with Specification 536. Use Hex Nuts, Hex Jam Nuts, and Washers in accordance with the AASHTO-AGC-ARTBA Guide to Standardized Barrier Hardware with English unit equivalents of components FN24a and FWC24a, respectively. Two Hex Nuts may be used for the Hex Jam Nut System.
- PLATE STOP-NAILS: To prevent rotation of the Bearing Plate, drive steel 2 1/2 inch Type 8d nails with ASTM A153 hot-dip galvanization.
- CABLE ANCHOR PLATE ASSEMBLY INSTALLATION: Mount to the pre-fabricated Cable Anchor Plate Bolt Holes in the W-Beam Panel, as shown on Sheet 4. These panel holes are only permitted for this Cable Anchor Plate Assembly application.
- SOIL PLATE BOLT HOLE(S): For Trailing Anchorage installations as shown on Sheet 9, the two bolt holes shown may be substituted with a single bolt hole located at the tube centerline.

END TREATMENT - COMPONENT DETAILS

10/20/2022 8:53:10 AM

LAST REVISION 11/01/19	DESCRIPTION:		FY 2023-24 STANDARD PLANS	GUARDRAIL	INDEX	SHEET
			536-001		10 of 24	

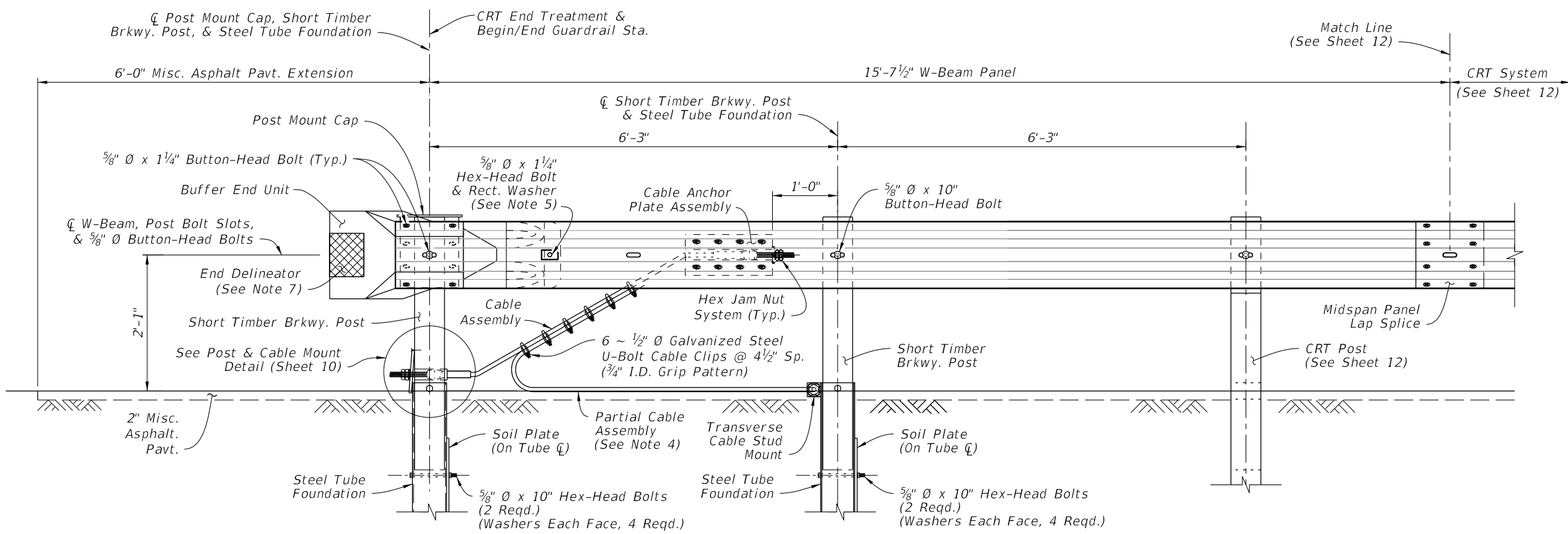

INSTALLED ELEVATION

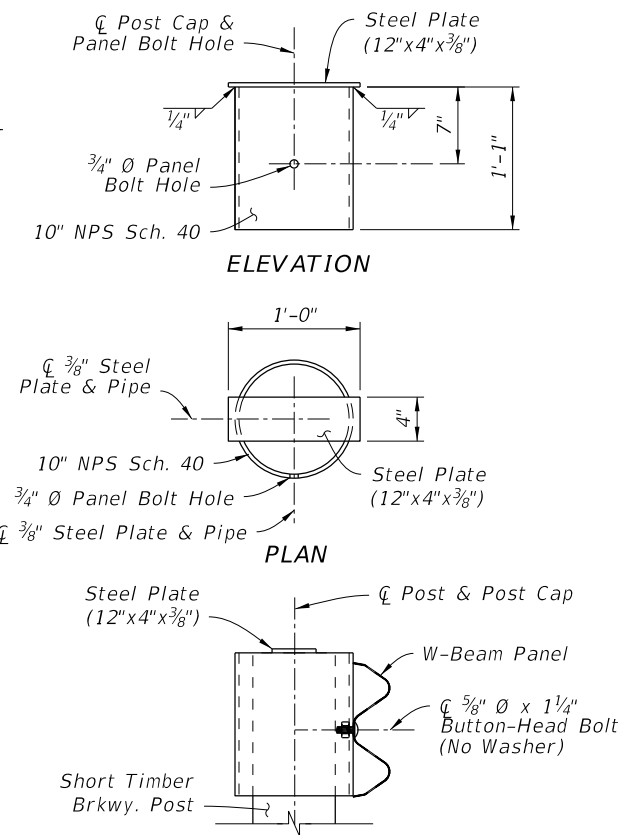

INSTALLED SECTION

POST MOUNT CAP

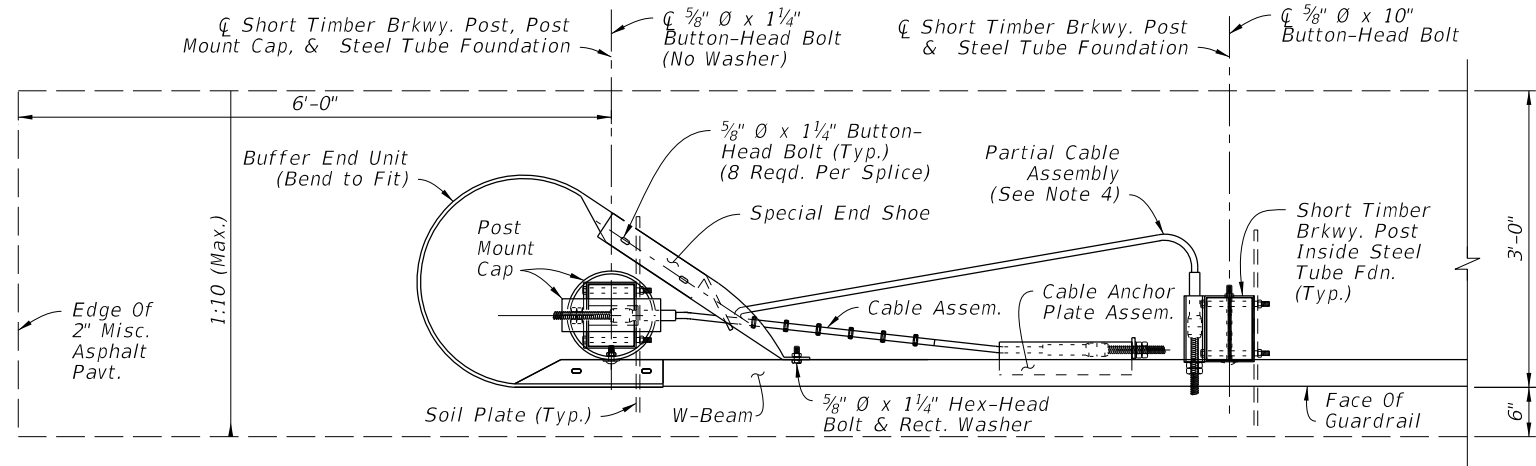

INSTALLED PLAN

CRT END TREATMENT ASSEMBLY

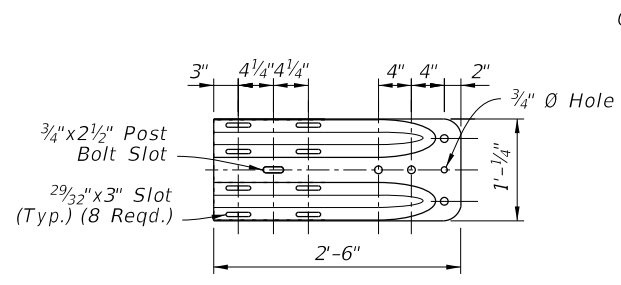

ELEVATION

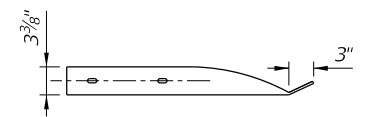

PLAN

SPECIAL END SHOE

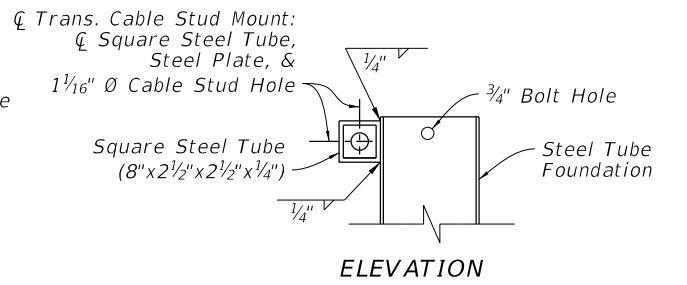

ELEVATION

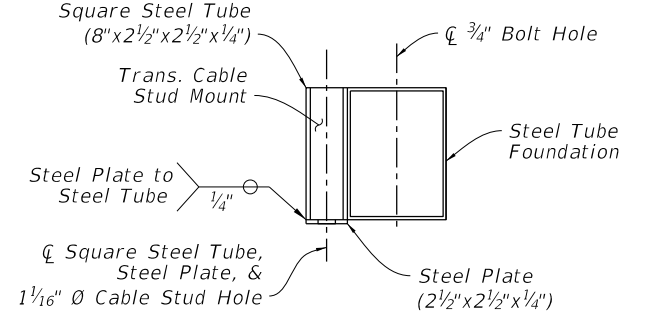

PLAN

TRANSVERSE CABLE STUD MOUNT

NOTES:

- INSTALLATION:** Use with CRT Systems as required on Sheet 12.
- COMPONENT DETAILS:** For additional component details, See Sheet 10 & 12. For the Rectangular Washer detail, see Sheet 24.
- MATERIALS:** Use steel End Shoes, Plates, Tubes, and pipes in accordance with Specification 967.
- PARTIAL CABLE ASSEMBLY:** The Partial Cable Assembly is similar to the Cable Assembly defined on Sheet 10, except with a 9'-0" total length and the Swage Fitting and Cable Stud omitted from one end.
Feed the Cable Stud through the Cable Stud Hole of the Transverse Cable Stud Mount as shown, and secure it with the Hex Jam Nut System as defined on Sheet 10.
- SPECIAL END SHOE MOUNT:** Punch a 3/4" Ø hole in the W-Beam Panel as needed to secure the Special End Shoe with the 5/8" Ø Hex-Head Bolt. Galvanize hole per Specification 562.
- FOUNDATIONS:** Install Steel Tubes with attached Soil Plates by either of the following methods:
 - Excavate, backfill, and compact material to provide full passive soil resistance to all surfaces of the tube and soil plate.
 - Drive the steel tube and soil plate as a single unit using a dummy timber post to prevent damage to the breakaway post.
- END DELINEATOR:** Mount retroreflective sheeting to the approach face of the Buffer End Unit in accordance with Specifications 536 and 967.

END TREATMENT - CONTROLLED RELEASE TERMINAL (CRT) SYSTEM

10/20/2022 8:53:11 AM

LAST REVISION 11/01/19	DESCRIPTION:	 FY 2023-24 STANDARD PLANS	GUARDRAIL	INDEX 536-001	SHEET 11 of 24
---------------------------	--------------	--	-----------	------------------	-------------------

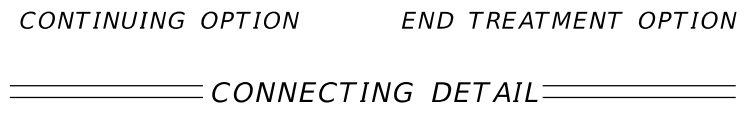
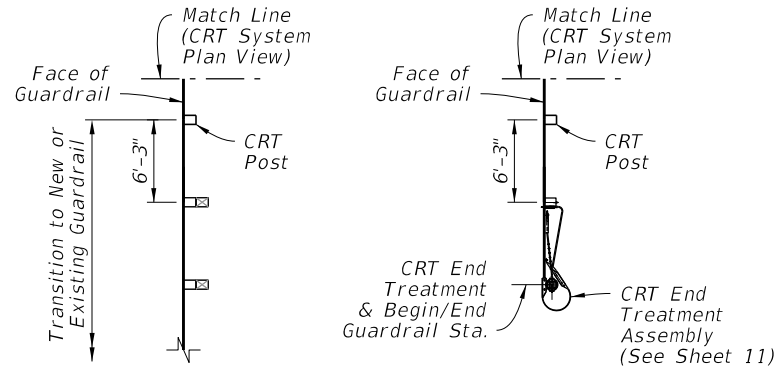
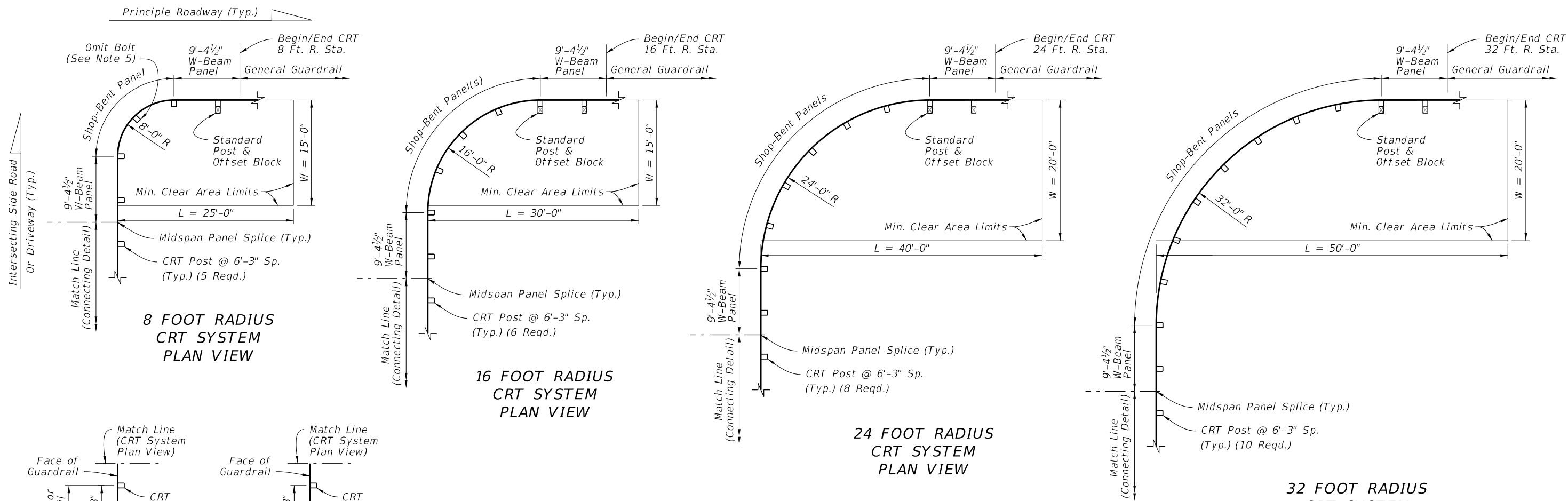

CRT SYSTEM SUMMARY TABLE:

RETURN RADIUS (FT.)	LENGTH OF SHOP-BENT PANEL(S) (FT.)	QUANTITY OF CRT POSTS	AREA CLEAR OF HAZARDS 'L' x 'W' (FT.)
8	12.5	5	25 x 15
16	25.0	6	30 x 15
24	37.5	8	40 x 20
32	50.0	10	50 x 20

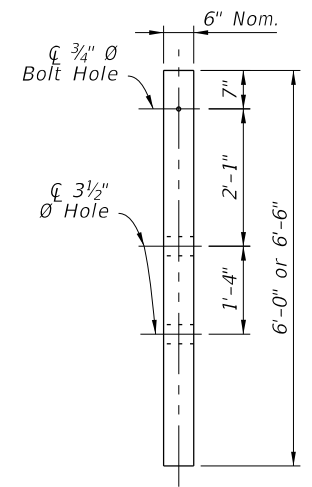

CRT POST ELEVATION (6"x8" Nom. Timber)

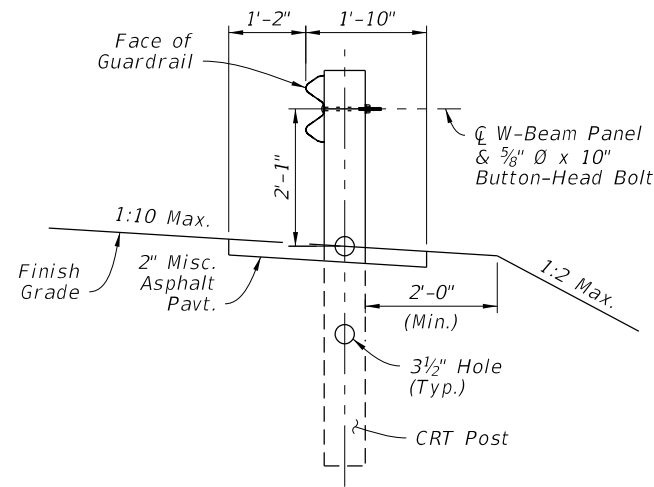

CRT INSTALLED SECTION

NOTES:

1. INSTALLATION: Construct the specified radius layout and Connecting Detail option as shown in the plans.
2. MIN. CLEAR AREA: Keep the area behind the CRT free of fixed objects and aboveground hazards within the Min. Clear Area limits shown. Maintain a slope not steeper than 1:10 for a minimum 2' behind the posts, and maintain a slope not steeper than 1:2 beyond 2' from the posts.
3. APPROACH GRADING: Maintain grading on the roadway side of the guardrail face at a maximum slope of 1:10.
4. MATERIALS: For CRT Posts, use Timber Post material in accordance with Specification 967. Use steel panels and hardware in accordance with Specification 967.
5. BOLT OMISSION: For the 8 Foot Radius CRT System only, do not place a panel-to-post mount bolt at the center CRT Post (omit the 5/8" Button-Head Bolt only at the location shown).
6. SHOP-BENT PANELS: Install Shop-Bent panel(s) where indicated using 12'-0" or 25'-0" W-Beam Panels. Splice at post locations within the CRT radius using the General configuration of 5/8" Ø Button-Head Bolts (8 reqd. per splice).
7. GENERAL GUARDRAIL: General Guardrail typically includes Panels and Post Spacing as shown on Sheet 2, including parallel and tapered segments. Approach Transitions, Low-Speed Guardrail, or Reduced Post Spacing Guardrail segments may be substituted for the General Guardrail shown herein if indicated in the plans.

LAYOUT FOR CONTROLLED RELEASE TERMINAL (CRT) SYSTEMS - SIDE ROADS AND DRIVEWAYS

10/20/2022 8:53:12 AM

LAST REVISION 11/01/19	DESCRIPTION:	 FY 2023-24 STANDARD PLANS	GUARDRAIL	INDEX 536-001	SHEET 12 of 24
---------------------------	--------------	----------------------------------	-----------	------------------	-------------------

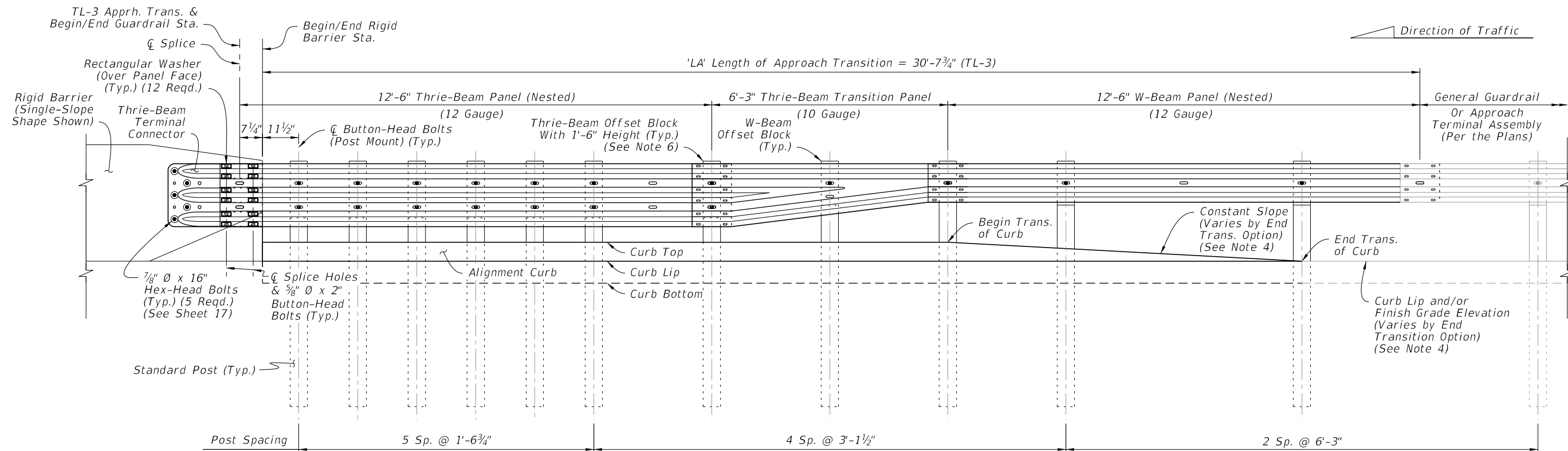

**TL-3 APPROACH TRANSITION
INSTALLED ELEVATION**

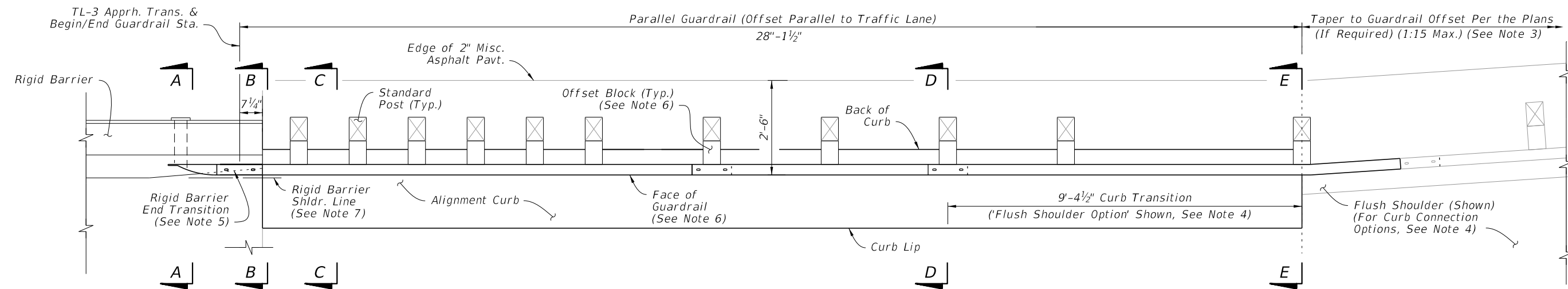

**TL-3 APPROACH TRANSITION
INSTALLED PLAN**

NOTES:

- INSTALLATION:** Construct the Approach Transition segment where indicated in the plans. For example Layouts showing the Approach Transition's fit among other guardrail segments, see Sheet 19.
For existing bridge connection options, see Indexes 536-002, 521-404, and 521-405.
- SECTION VIEWS & DETAILS:** For cross sections and details, including the barrier mounting hardware, curb transition, adjacent grading, and installation dimensions, see Sheet 17.
- GUARDRAIL TAPER:** The connecting guardrail may require a different lateral offset if shown in the plans. At the location shown herein, taper the guardrail to the connecting guardrail offset. If the adjacent guardrail segment has the same offset as the Approach Transition segment, then no taper is required.
- END TRANSITION OF CURB OPTIONS:** The Plan and Elevation views depict an example Curb Transition to Flush Shoulder from Section D-D to E-E, but this transition may require a different shape depending on the End Transition option shown in the plans (Either a 'Shoulder Gutter Option', 'Raised Curb Option', or 'Flush Shoulder Option'). See Sheet 14 for additional curb options and Sheet 17 for curb shape details.
- RIGID BARRIER END TRANSITION:** Taper the Rigid Barrier toe as shown. See Concrete Barrier, Index 521-001, and Traffic Railing, Indexes 521-422 and 521-428, for details.
- OFFSET BLOCKS:** For Thrie-Beam post locations within the Length of Approach Transition segment, use the Timber Offset Blocks with 1'-6" height shown on Sheet 6.
For the midspan of the Thrie-Beam Transition Panel and for all other W-Beam locations shown herein, use the W-Beam Offset Blocks with 1'-2" height.
- OFFSET:** The required offset difference between the Face of Guardrail and Rigid Barrier Shoulder Line is considered negligible and may not be shown in the guardrail offset callouts in the plans. A consistent guardrail offset deviation of up to 4 inches outside of the Rigid Barrier Shoulder Line is permitted over the length 'LA'.
- GENERAL GUARDRAIL:** General Guardrail typically includes Panels and Post Spacing as shown on Sheet 2, including parallel and tapered segments. Approach Terminals, Low-Speed Guardrail, or Reduced Post Spacing Guardrail segments may be substituted for the General Guardrail shown herein if indicated in the plans.

APPROACH TRANSITION CONNECTION TO RIGID BARRIER - GENERAL, TL-3

10/20/2022 8:53:13 AM

LAST REVISION 11/01/19	REVISION	DESCRIPTION:		FY 2023-24 STANDARD PLANS	GUARDRAIL	INDEX 536-001	SHEET 13 of 24
---------------------------	----------	--------------	---	------------------------------	-----------	------------------	-------------------

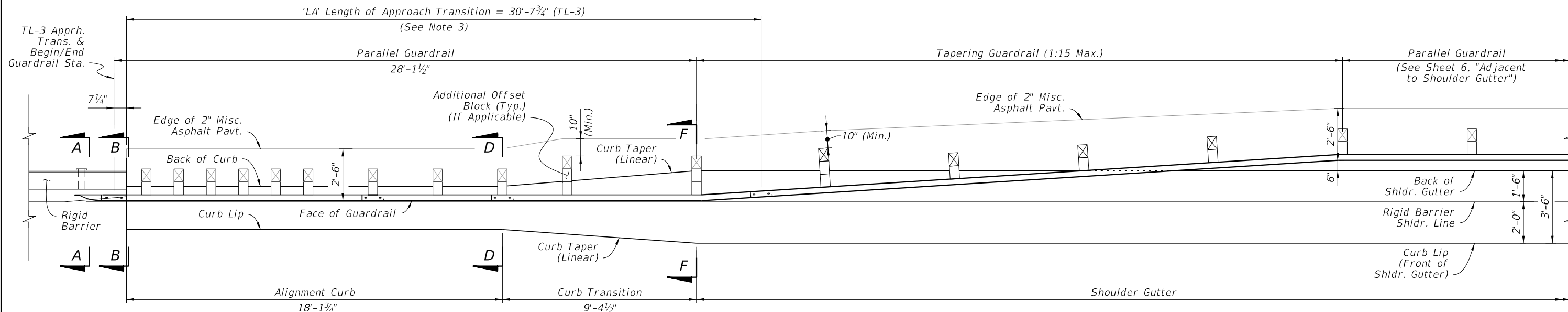

TL-3 APPROACH TRANSITION WITH 'SHOULDER GUTTER' CONNECTION - PLAN VIEW

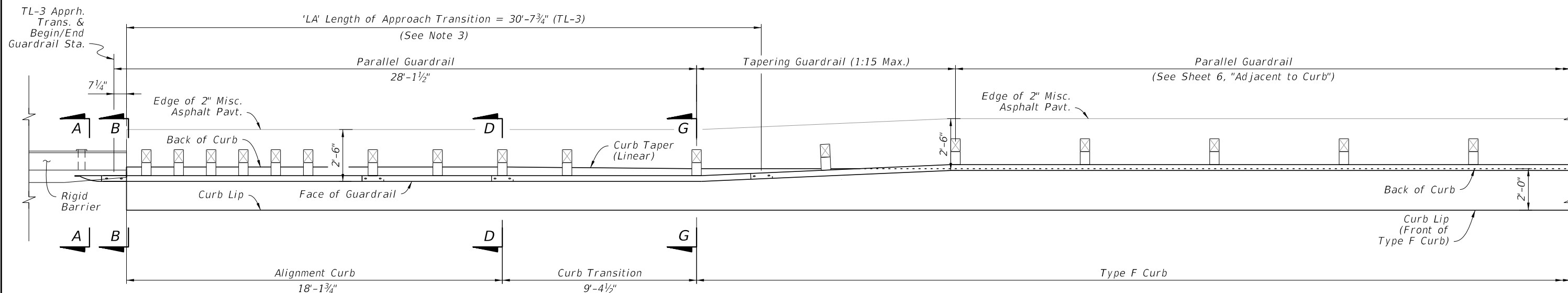

TL-3 APPROACH TRANSITION WITH 'TYPE F CURB' CONNECTION - PLAN VIEW

NOTES:

1. GENERAL: See the applicable notes and details on Sheet 13.
2. SECTION VIEWS & DETAILS: For cross sections and details, including the barrier mounting hardware, curb transition, adjacent grading, and installation dimensions, see Sheet 17.
3. ELEVATION VIEW: For post and panel installation details within 'LA', see the elevation view on Sheet 13. The curb details will differ depending on curb option required.

APPROACH TRANSITION CONNECTION TO RIGID BARRIER - GENERAL, TL-3 CURB CONNECTIONS

LAST REVISION 11/01/19	REVISION	DESCRIPTION:	 FY 2023-24 STANDARD PLANS	GUARDRAIL	INDEX 536-001	SHEET 14 of 24
---------------------------	----------	--------------	---	-----------	------------------	-------------------

10/20/2022 8:53:14 AM

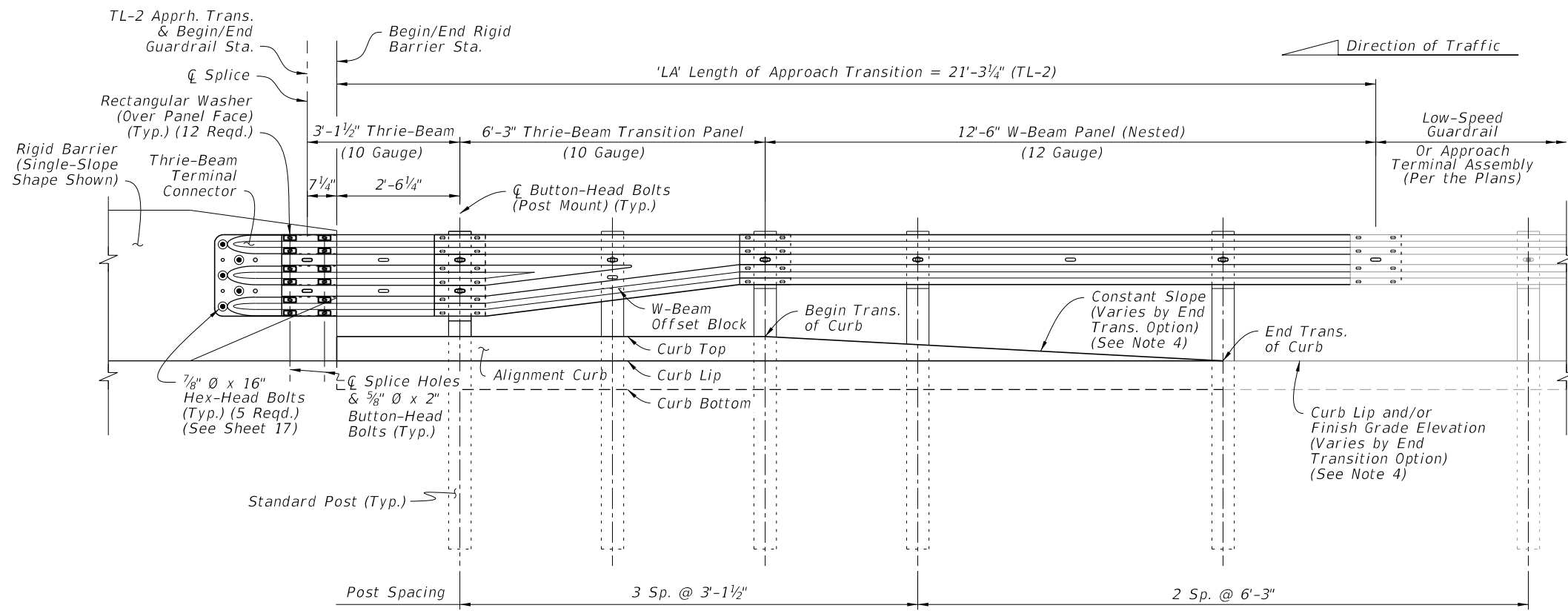

**TL-2 APPROACH TRANSITION
INSTALLED ELEVATION**

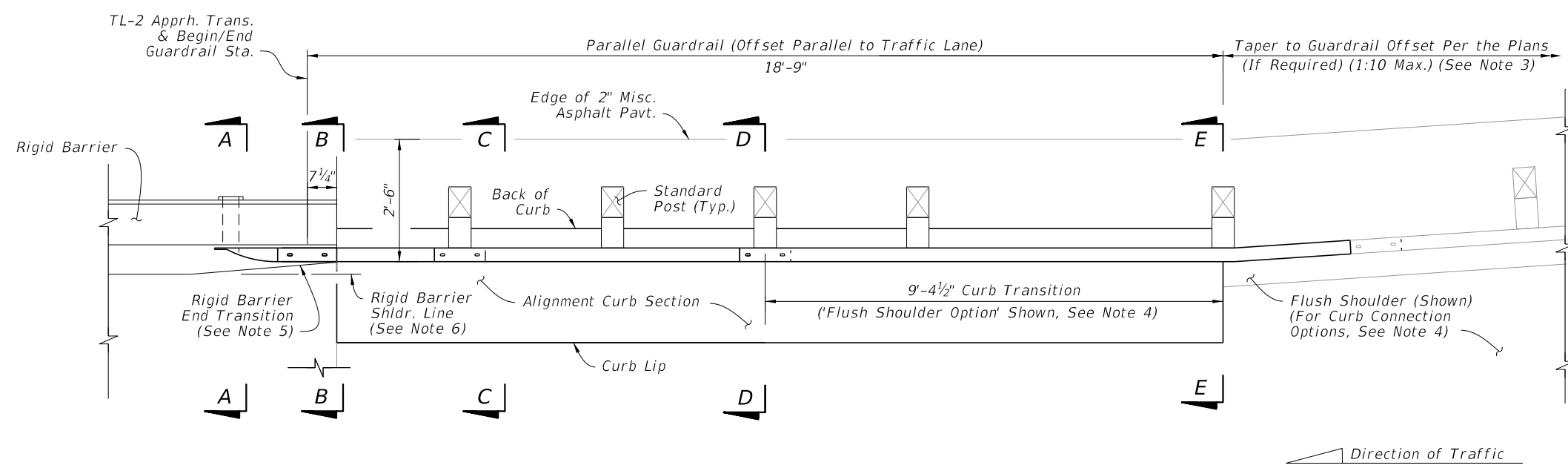

**TL-2 APPROACH TRANSITION
INSTALLED PLAN**

NOTES:

1. **INSTALLATION:** Construct the Approach Transition segment where indicated in the plans. For example Layouts showing the Approach Transition's fit among other guardrail segments, see Sheet 19.

For existing bridge connection options, see Indexes 536-002, 521-404, and 521-405.
2. **SECTION VIEWS & DETAILS:** For cross sections and details, including the barrier mounting hardware, curb transition, adjacent grading, and installation dimensions, see Sheet 17.
3. **GUARDRAIL TAPER:** The connecting guardrail may require a different lateral offset if shown in the plans. At the location indicated herein, taper the guardrail to the connecting guardrail offset. If the adjacent guardrail segment has the same offset as the Approach Transition segment, then no taper is required.
4. **END TRANSITION OF CURB OPTIONS:** The Plan and Elevation views depict an example Curb Transition to Flush Shoulder from Section D-D to E-E, but this transition may require a different shape depending on the End Transition option shown in the plans (Either a 'Shoulder Gutter Option', 'Raised Curb Option', or 'Flush Shoulder Option'). See Sheet 16 for additional curb options and Sheet 17 for curb shape details.
5. **RIGID BARRIER END TRANSITION:** Taper the Rigid Barrier toe as shown. See Concrete Barrier, Index 521-001, and Traffic Railing, Indexes 521-422 and 521-428, for details.
6. **OFFSET:** The required offset difference between the Face of Guardrail and Rigid Barrier Shoulder Line is considered negligible and may not be shown in the guardrail offset callouts in the plans. A consistent guardrail offset deviation of up to 4 inches outside of the Rigid Barrier Shoulder Line is permitted over the length 'LA'.
7. **GENERAL GUARDRAIL:** General Guardrail typically includes Panels and Post Spacing as shown on Sheet 2, including parallel and tapered segments. Approach Terminals, Low-Speed Guardrail, or Reduced Post Spacing Guardrail segments may be substituted for the General Guardrail shown herein if indicated in the plans.

APPROACH TRANSITION CONNECTION TO RIGID BARRIER - LOW-SPEED, TL-2

10/20/2022 8:53:15 AM

LAST REVISION 11/01/19	REVISION	DESCRIPTION:		FY 2023-24 STANDARD PLANS	GUARDRAIL	INDEX 536-001	SHEET 15 of 24
---------------------------	----------	--------------	--	------------------------------	-----------	------------------	-------------------

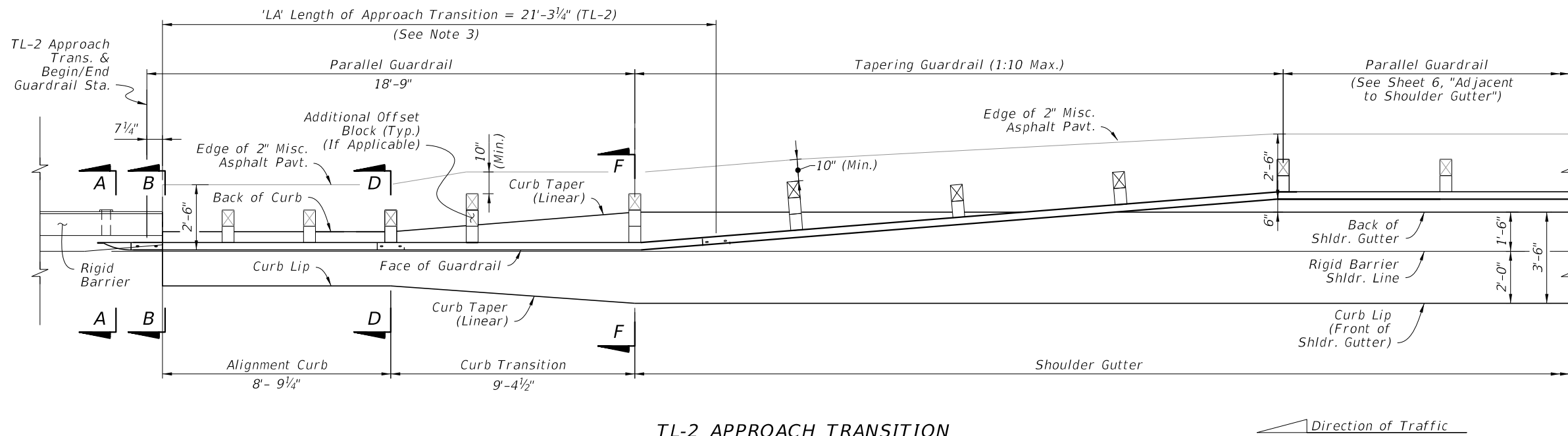

TL-2 APPROACH TRANSITION WITH 'SHOULDER GUTTER' CONNECTION - PLAN VIEW

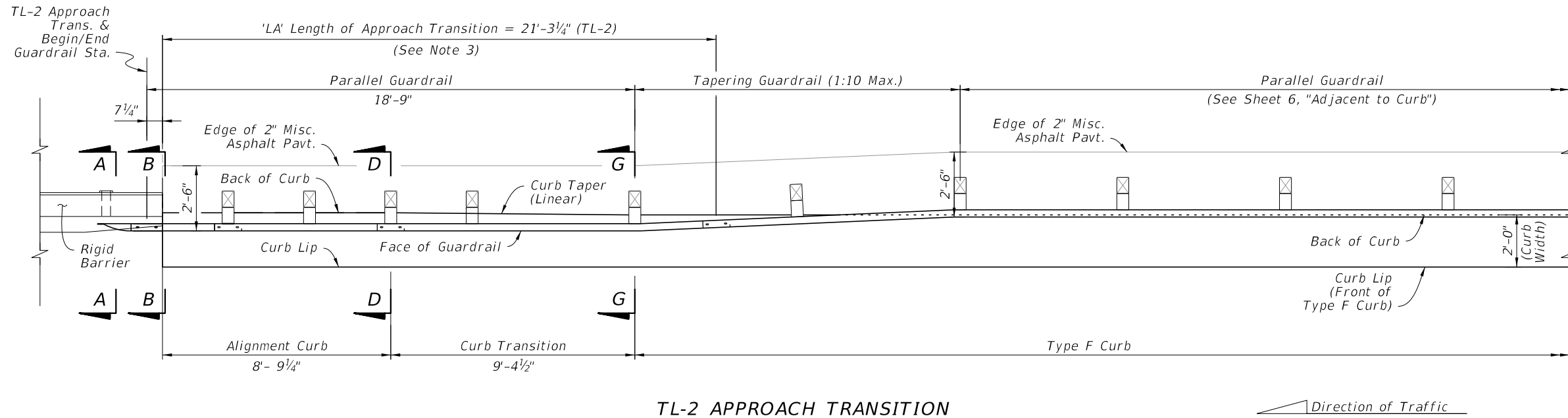

TL-2 APPROACH TRANSITION WITH 'TYPE F CURB' CONNECTION - PLAN VIEW

NOTES:

1. GENERAL: See the applicable notes and details on Sheet 15.
2. SECTION VIEWS & DETAILS: For cross sections and details, including the barrier mounting hardware, curb transition, adjacent grading, and installation dimensions, see Sheet 17.
3. ELEVATION VIEW: For post and panel installation details within 'LA', see the elevation view on Sheet 15. The curb details will differ depending on curb option required.

APPROACH TRANSITION CONNECTION TO RIGID BARRIER - LOW-SPEED, TL-2 CURB CONNECTIONS

10/20/2022 8:53:16 AM

LAST REVISION 11/01/19	REVISION	DESCRIPTION:		FY 2023-24 STANDARD PLANS	GUARDRAIL	INDEX 536-001	SHEET 16 of 24
---------------------------	----------	--------------	--	------------------------------	-----------	------------------	-------------------

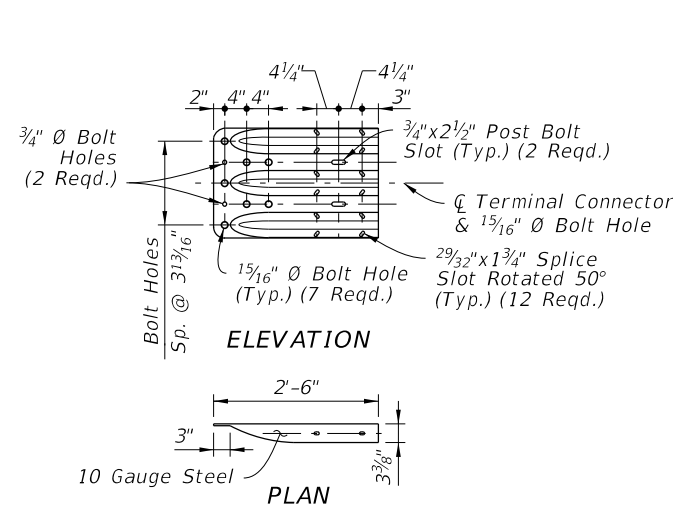

THRIE-BEAM TERMINAL CONNECTOR DETAIL

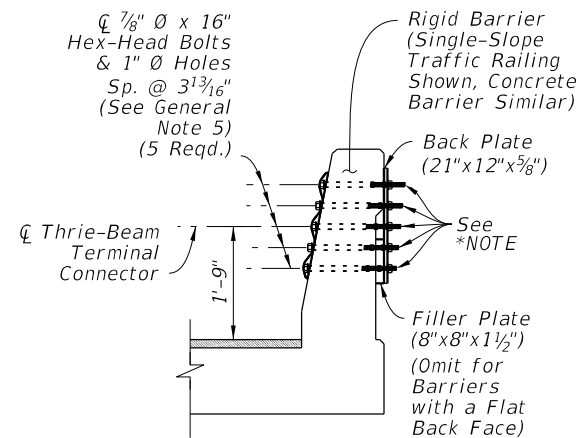

SECTION A-A RIGID BARRIER TERMINAL CONNECTOR MOUNT

*NOTE: For locations within 4'-0" of a sidewalk or shared use path, trim bolts down to within 1/4" of tightend nut. Deform exposed threads. File down sharp edges and burrs.

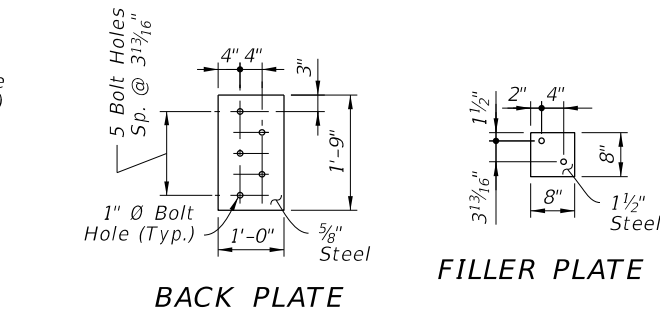

BACK PLATE

FILLER PLATE

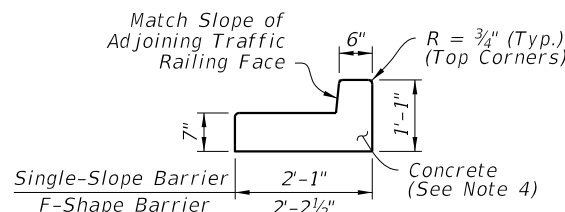

ALIGNMENT CURB SECTION

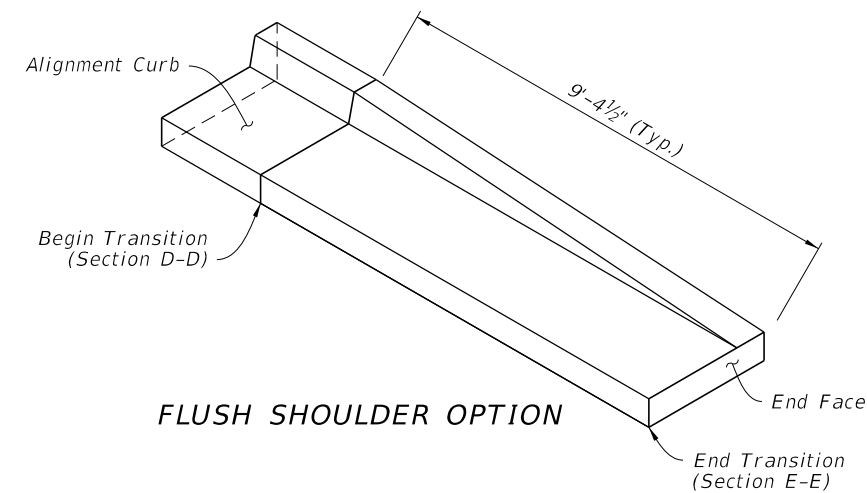

FLUSH SHOULDER OPTION

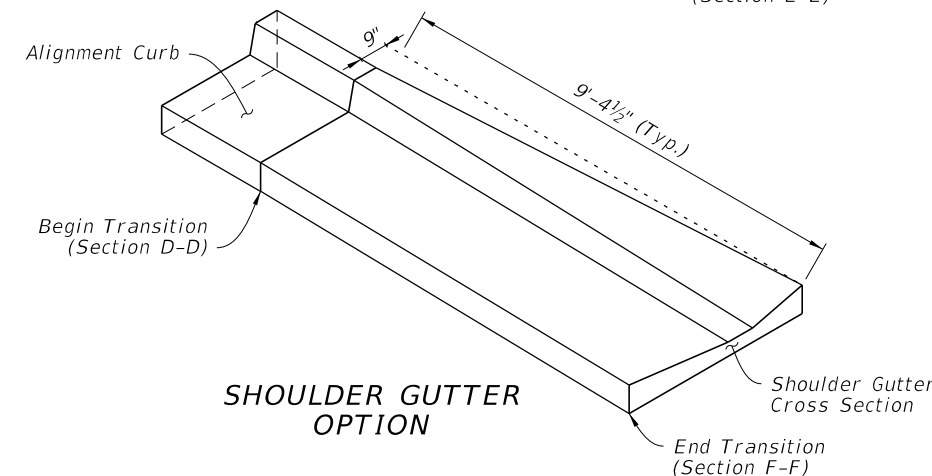

SHOULDER GUTTER OPTION

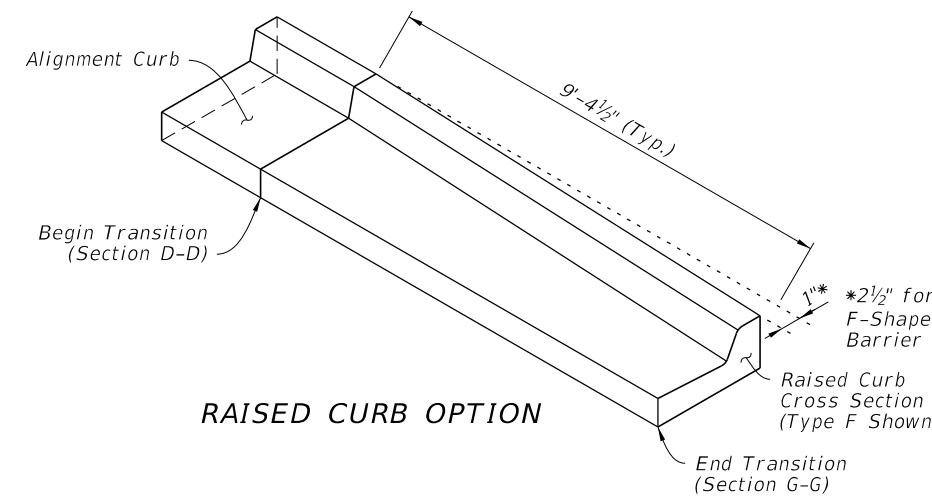

RAISED CURB OPTION

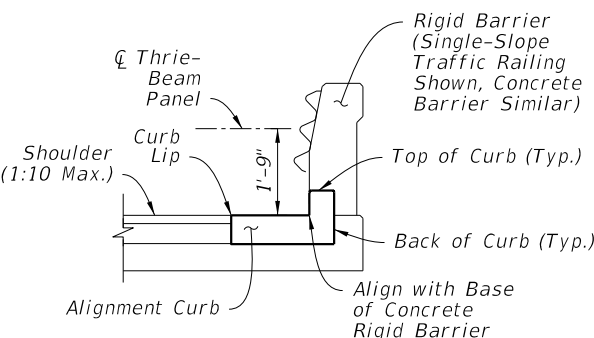

SECTION B-B BEGIN ALIGNMENT CURB (Mate to Rigid Barrier)

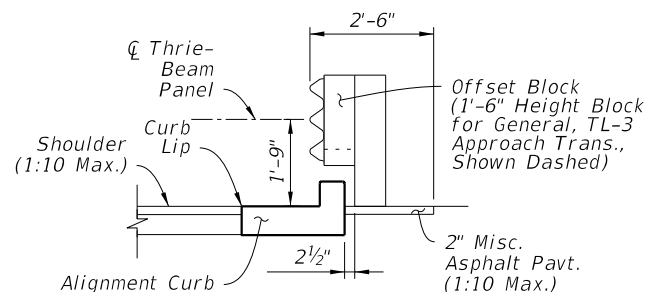

SECTION C-C ALIGNMENT CURB (Intermediate)

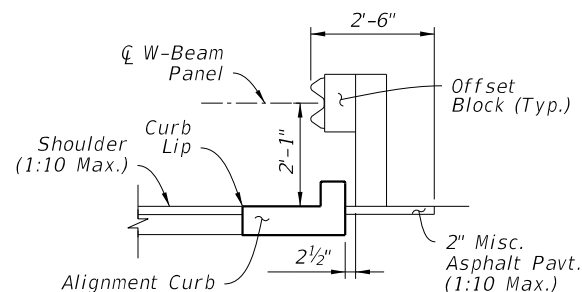

SECTION D-D BEGIN TRANSITION (End Alignment Curb)

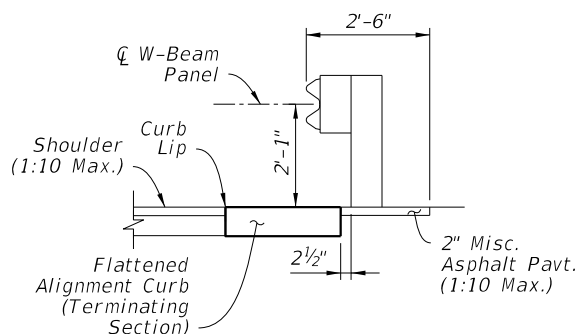

SECTION E-E END TRANSITION FLUSH SHOULDER OPTION

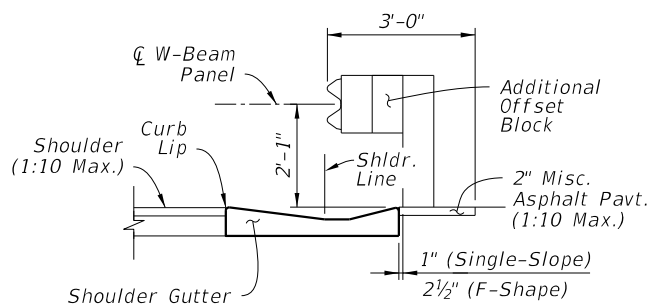

SECTION F-F END TRANSITION SHOULDER GUTTER OPTION

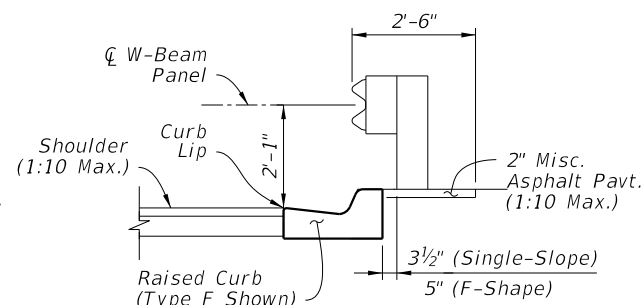

SECTION G-G END TRANSITION RAISED CURB OPTION

CURB TRANSITION ISOMETRIC VIEWS

- NOTES:**
1. PLAN AND ELEVATION VIEWS: Work with Sheets 13 thru 16.
 2. END TRANSITION OF CURB OPTION: Install one of the three End Transition types shown per Section E-E as indicated by the plans.
 3. GRADING BEHIND POSTS: Place Slope Break a Min. 2'-0" behind the post, per Sheet 6.
 4. MATERIALS & CONSTRUCTION: Construct the concrete Aligning Curb and Curb transition in accordance with Specification 520. Use steel Plates and Thrie-Beam Terminal Connectors in accordance with Specification 967.

APPROACH TRANSITION CONNECTION - DETAILS

CURB TYPICAL SECTIONS

10/20/2022 8:53:17 AM

LAST REVISION 11/01/19	DESCRIPTION:		FY 2023-24 STANDARD PLANS		INDEX 536-001	SHEET 17 of 24
REVISION						

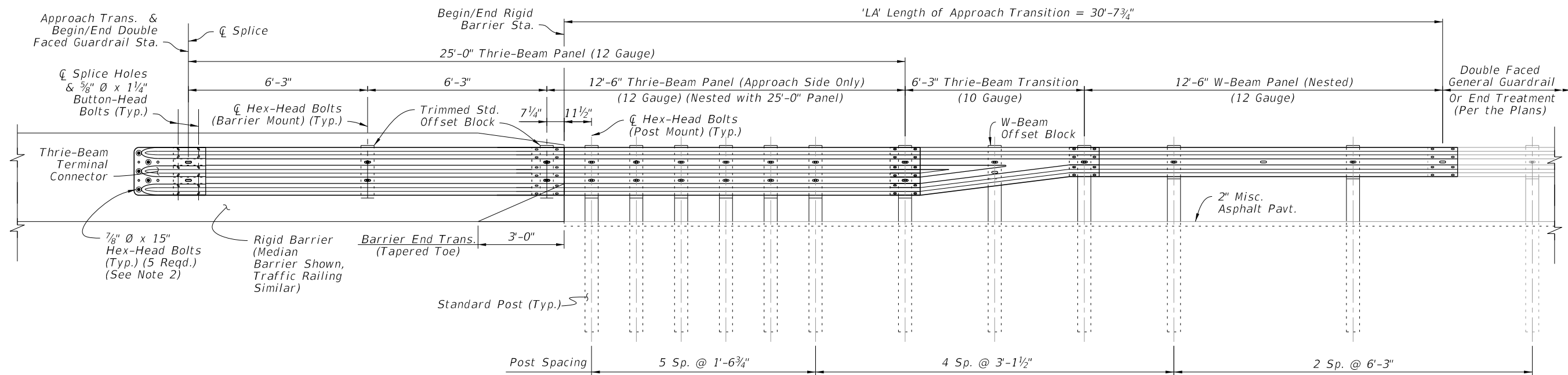

**TL-3 DOUBLE FACED APPROACH TRANSITION
INSTALLED ELEVATION**

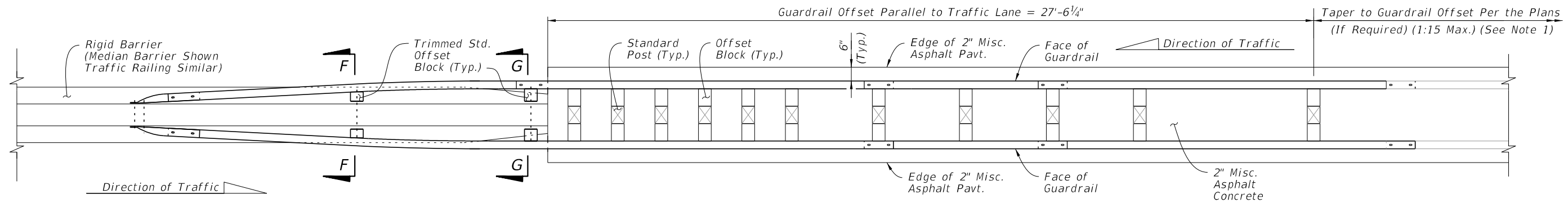

**TL-3 DOUBLE FACED APPROACH TRANSITION
INSTALLED PLAN**

NOTES:

- INSTALLATION:** Construct the Approach Transition segment where indicated in the plans. The required offset of the connecting adjacent guardrail is shown in the plans.
The Layout given on Sheet 20 provides a basic scheme for connections to adjacent guardrail, where a taper to a differing guardrail offset may be required. If the adjacent guardrail has the same offset as the Approach Transition segment, then no taper is required.
- THRIE-BEAM TERMINAL CONNECTOR:** See Sheet 17 for Details. The installed bolt's threaded portion is not permitted to extend beyond 3#4" from the face of the nut; trim the threaded portion as needed and galvanize in accordance with Specification 562.
- GENERAL GUARDRAIL:** General Guardrail typically includes Panels and Post Spacing as shown on Sheet 2, including parallel and tapered segments. End Treatments or Reduced Post Spacing Guardrail segments may be substituted for the General Guardrail shown herein if indicated in the plans.

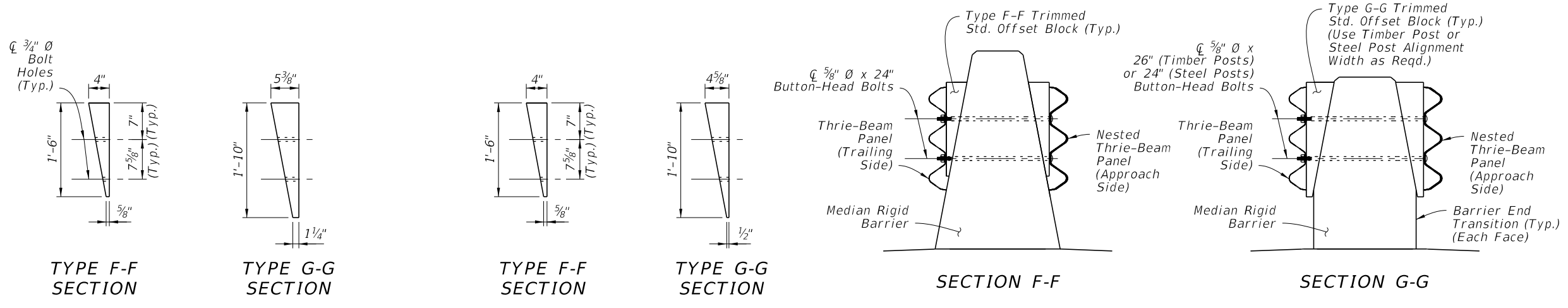

APPROACH TRANSITION CONNECTION TO RIGID BARRIER WITH DOUBLE FACED GUARDRAIL

10/20/2022 8:53:19 AM

LAST REVISION 11/01/19	REVISION	DESCRIPTION:		FY 2023-24 STANDARD PLANS	GUARDRAIL	INDEX	SHEET
						536-001	18 of 24

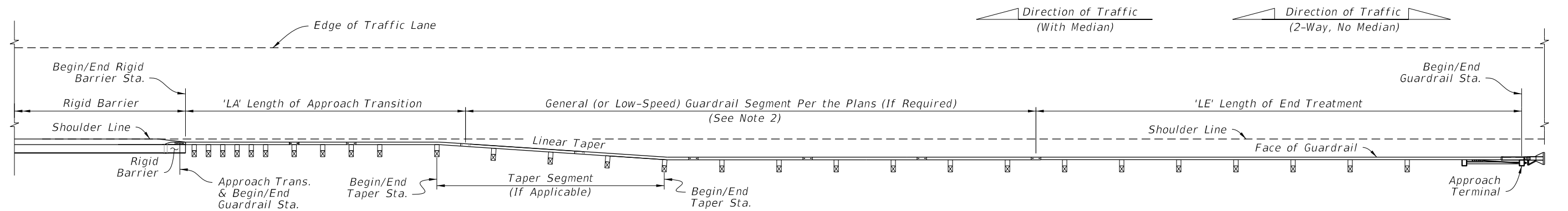

**TYPE A APPROACH TO RIGID BARRIER - PLAN VIEW
MEDIAN OR OUTSIDE SHOULDERS
(Mirror Horiz. and/or Vert. for Opposite
Direction and/or Side of Road)**

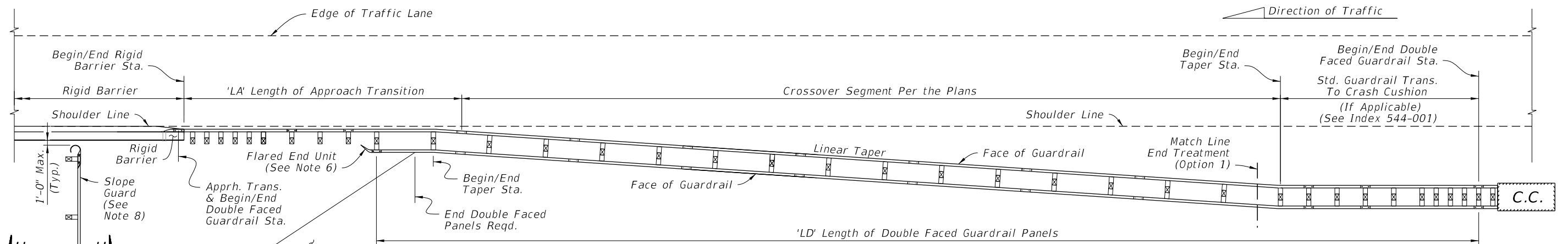

**TYPE B APPROACH TO RIGID BARRIER - PLAN VIEW
CROSSOVER GUARDRAIL FOR MEDIAN SHOULDERS ONLY
DUAL BRIDGE APPROACH CONFIGURATION
(Mirror Horiz. and Vert. for Opposite Direction)**

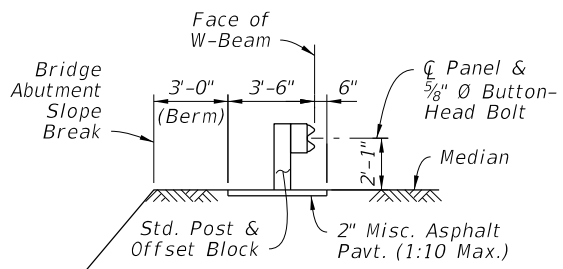
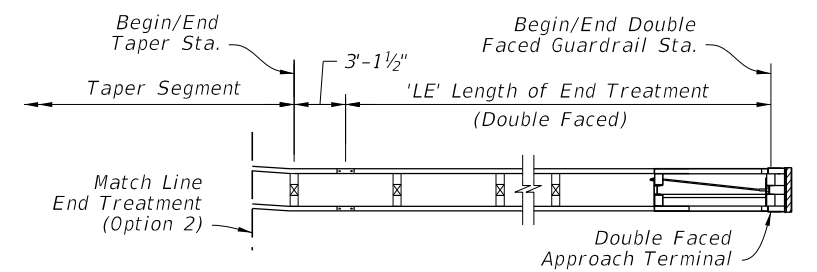

**SECTION H-H
BRIDGE ABUTMENT
SLOPE GUARD
(Between Bridges)**

NOTES:

- INSTALLATION:** The Plan Views shown are schematic only, showing example geometry for connecting guardrail segments including taper locations and Double Faced Guardrail requirements as applicable. Work this Sheet with the plans, where stationing and offsets for Begin/End Guardrail, Begin/End Rigid Barrier, and Begin/End Taper are specified. For existing bridge layouts, see Index 536-002, 521-404, and 521-405.
- GENERAL (OR LOW-SPEED) GUARDRAIL SEGMENT:** Construct this segment if shown in the plans. For the case where this segment's offset differs from the Approach Transition offset, linearly taper the guardrail between the Begin/End Taper Stations and offsets as specified in the plans.
For the shortest length case of a direct connection between the End Treatment and the Approach Transition, this segment may be omitted as shown in the plans.
- LENGTH OF APPROACH TRANSITION 'LA':** Install the applicable Approach Transition as shown per Sheets 13 thru 16, where called for in the plans.
- LENGTH OF END TREATMENT 'LE':** Install the Approach Terminal End Treatment as shown per Sheet 7 or 8, where called for in the plans. Use the corresponding APL drawings for construction details.
- CROSSOVER GUARDRAIL (FOR TYPE B APPROACH):** Install the Crossover Segment tapering linearly from the Begin Taper Sta. and offset to the End Taper Sta. and offset as specified in the plans.
- LENGTH OF DOUBLE FACED GUARDRAIL PANELS, 'LD' (FOR TYPE B APPROACH):** Terminate the Double Faced Guardrail panels as shown (based upon the 30° line measured from the hazard on the opposite side of the median). Extend the panel segment longer than the dimension 'LD' as needed for the Panel's end Bolt Slot to align with a post Bolt hole.
Install a Flared End Unit where shown, as defined on Sheet 9.
- END TREATMENT OPTIONS (FOR TYPE B & C APPROACH):** For Double Faced applications, use either a Double Faced Approach Terminal Assembly per Sheet 8 or a Crash Cushion per Index 544-001. For either Option, meet the 1:10 adjacent grading requirements for Approach Terminals as shown on Sheet 8.
- SLOPE GUARD:** Where indicated in the plans, install a Guardrail segment between bridge approaches and offset from the bridge abutment's Slope Break as shown. Install posts at the end bolt slots of the panel system. Use post spacing of either 3'-1 1/2" or 6'-3", as needed to correctly fit system between barriers. The system may also be lengthened to fit by installing two Rounded End Units as defined on Sheet 9.

LAYOUT TO RIGID BARRIER - APPROACH ENDS

10/20/2022 8:53:20 AM

LAST REVISION 11/01/19	DESCRIPTION:		FY 2023-24 STANDARD PLANS	GUARDRAIL	INDEX	SHEET
			536-001		19 of 24	

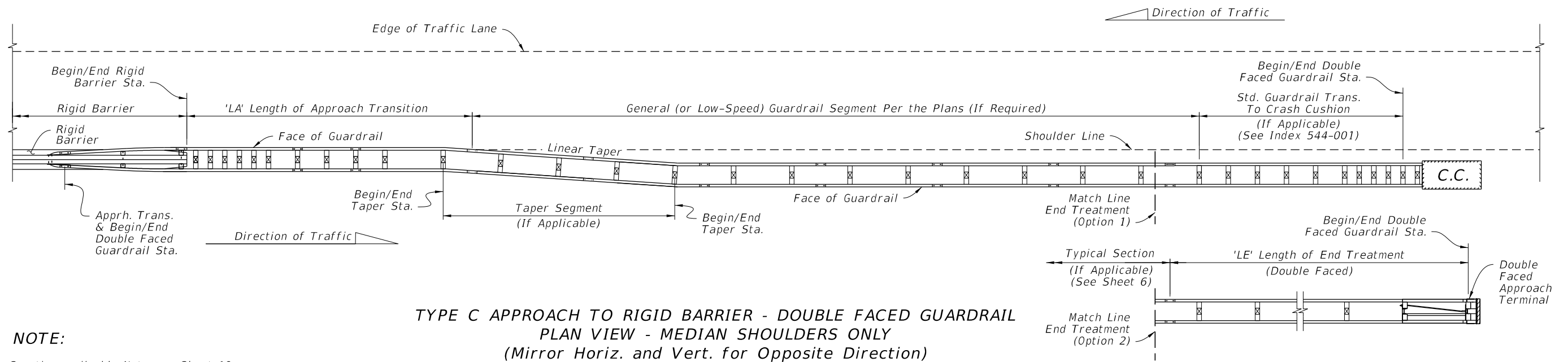

**TYPE C APPROACH TO RIGID BARRIER - DOUBLE FACED GUARDRAIL
PLAN VIEW - MEDIAN SHOULDERS ONLY
(Mirror Horiz. and Vert. for Opposite Direction)**

NOTE:
See the applicable Notes on Sheet 19.

**LAYOUT TO RIGID BARRIER -
APPROACH ENDS WITH
DOUBLE FACED GUARDRAIL**

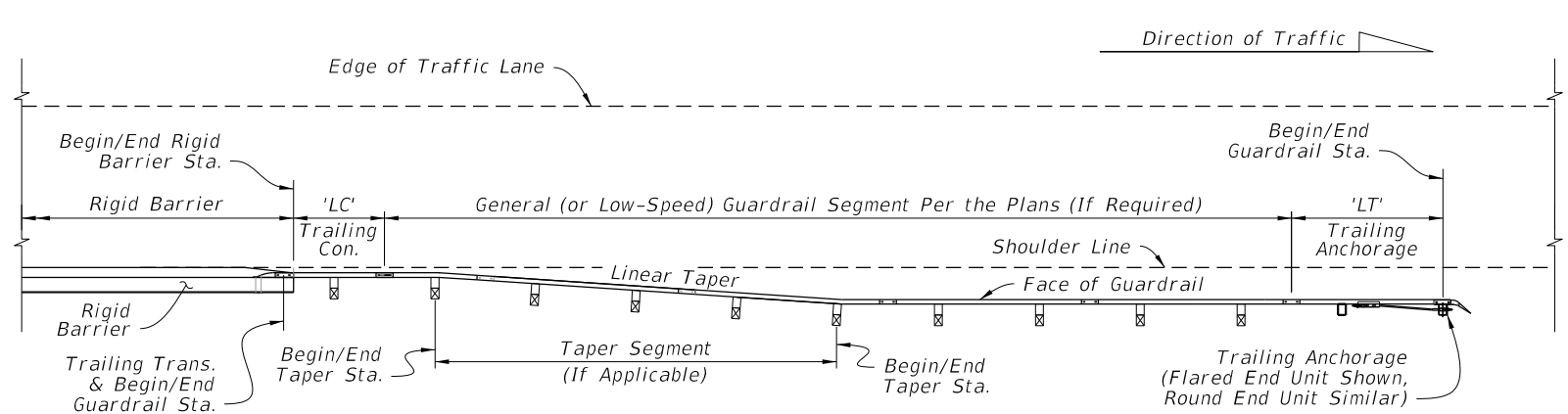

**TYPE D TRAILING CONNECTION FROM RIGID BARRIER
PLAN VIEW - MEDIAN OR OUTSIDE SHOULDER
(Mirror Horiz. and/or Vert. for Opposite
Direction and/or Side of Road)**

- NOTES:**
1. See the applicable Notes on Sheet 19.
 2. LENGTH OF TRAILING ANCHORAGE, 'LT': Install the Trailing Anchorage as shown on Sheet 9, where called for in the plans.
 3. THRIE-BEAM TERMINAL CONNECTOR: Install connector and bolts as shown on Sheet 17.
 4. RIGID BARRIER SINGLE SLOPE END FACE: See Concrete Barrier Wall, Index 521-001, and Traffic Railing, Indexes 521-422 and 521-423, for details.

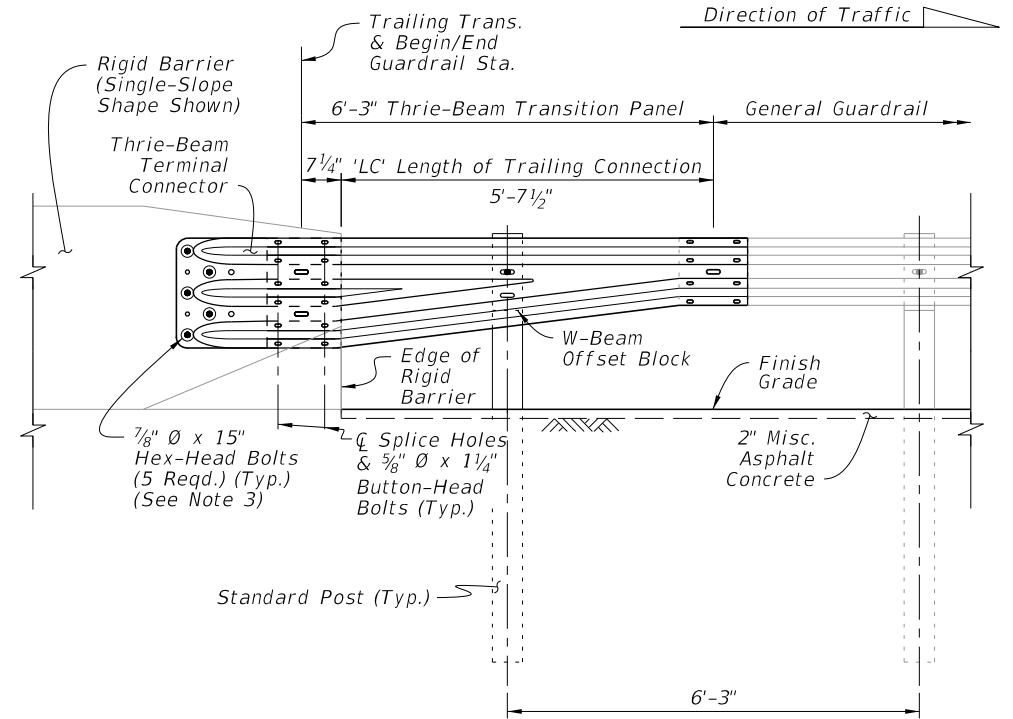

**TRAILING END TRANSITION CONNECTION
TO RIGID BARRIER - INSTALLED ELEVATION**

LAYOUT TO RIGID BARRIER - TRAILING ENDS

12/13/2022 8:36:04 AM

LAST REVISION 11/01/19	REVISION	DESCRIPTION:		FY 2023-24 STANDARD PLANS	GUARDRAIL	INDEX 536-001	SHEET 20 of 24
---------------------------	----------	--------------	--	------------------------------	-----------	------------------	-------------------

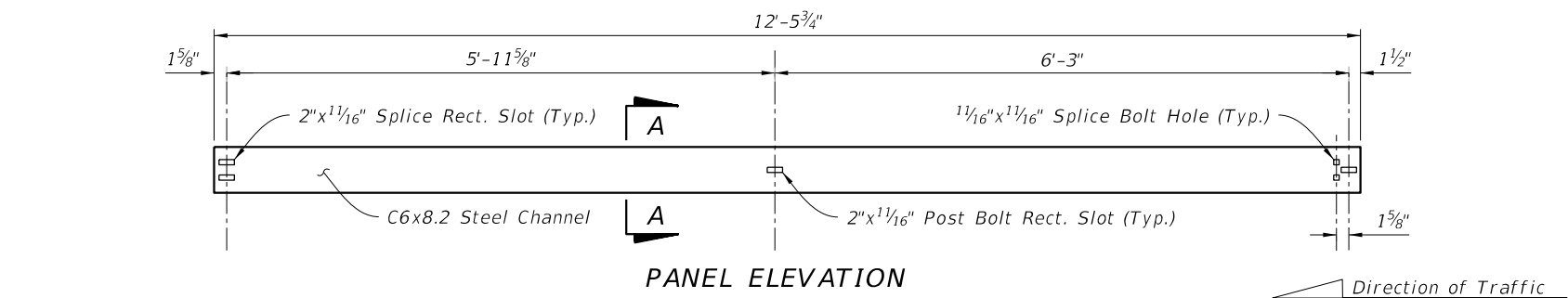

PANEL ELEVATION

Direction of Traffic

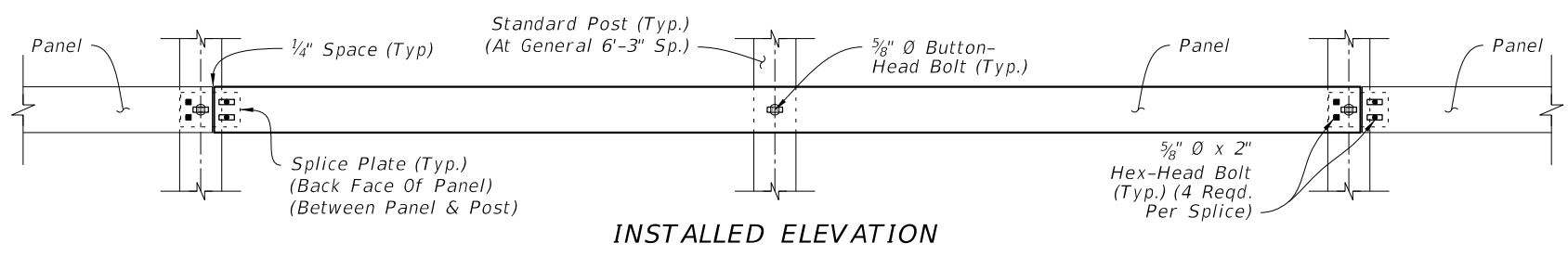

INSTALLED ELEVATION

CHANNEL SECTION RUB RAIL

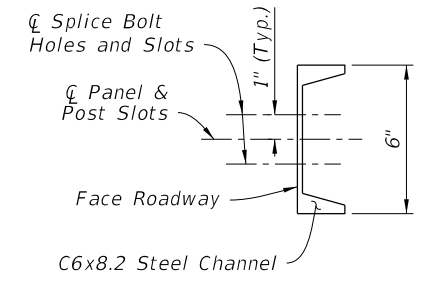

SECTION A-A (Panel Typical)

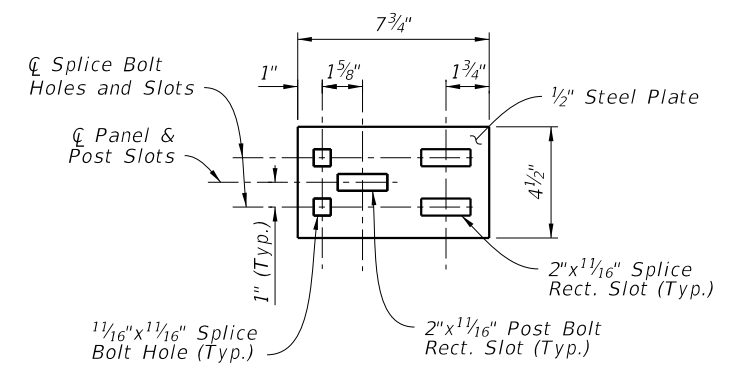

SPLICE PLATE ELEVATION

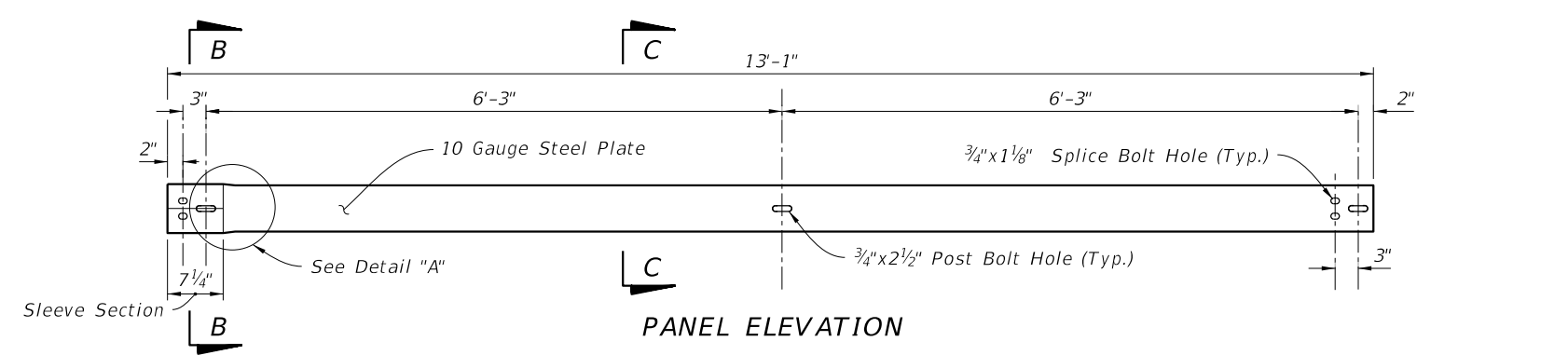

PANEL ELEVATION

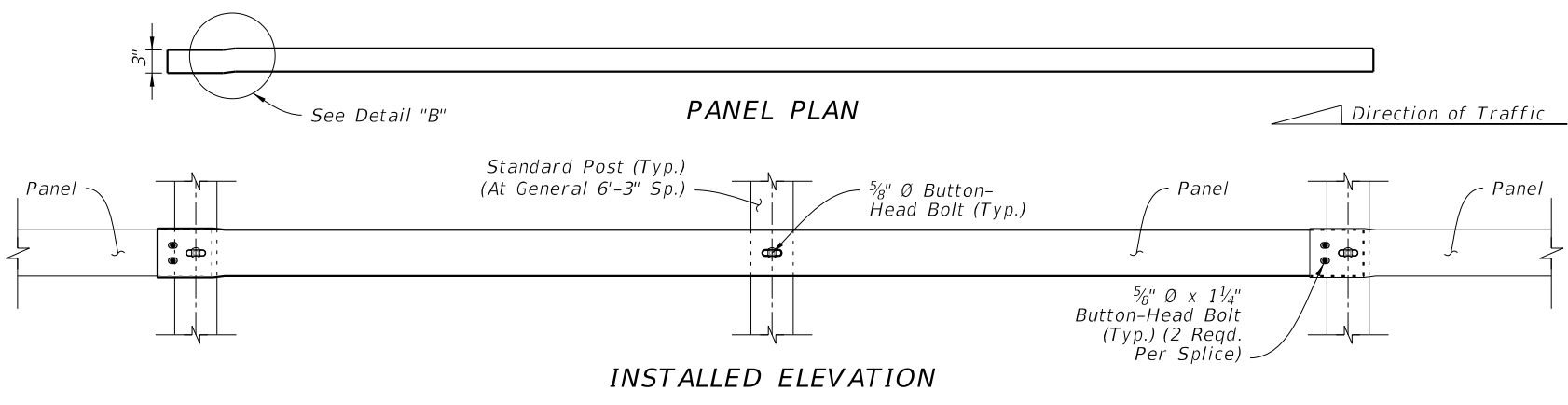

INSTALLED ELEVATION

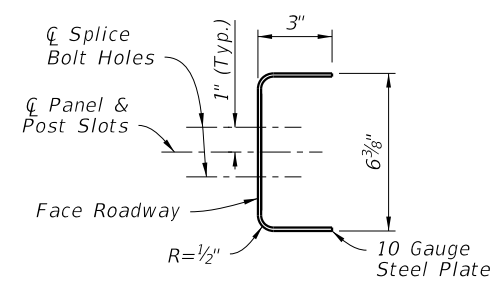

SECTION B-B (Panel Sleeve End)

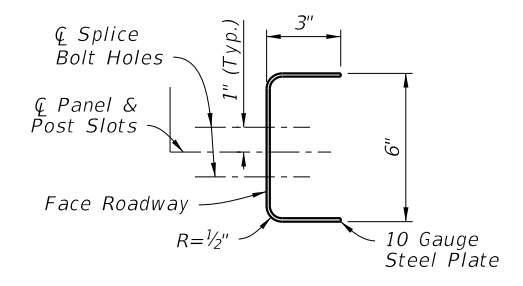

SECTION C-C (Panel Typical)

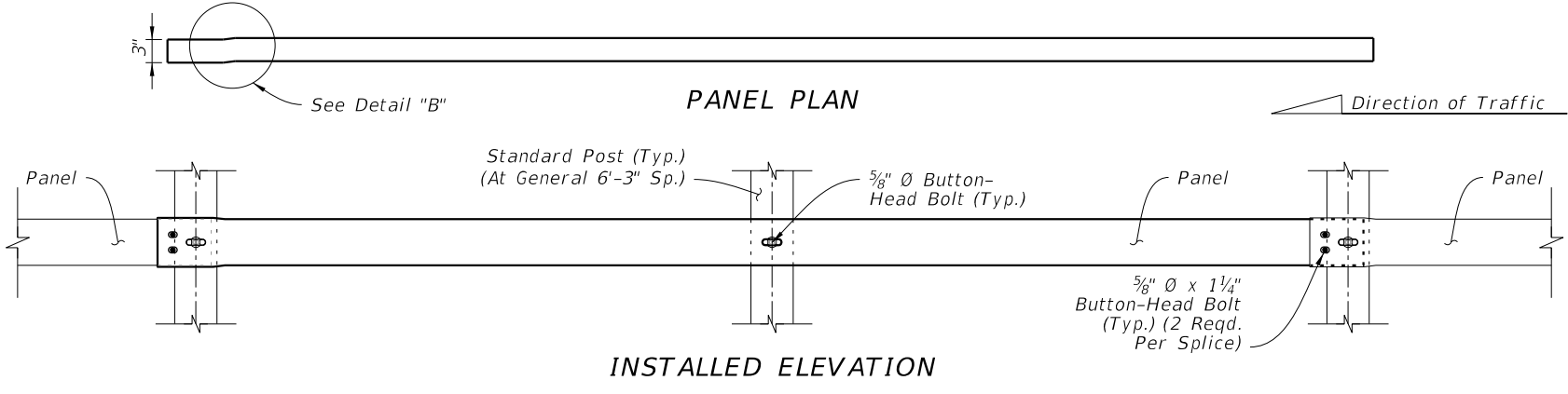

PANEL PLAN

Direction of Traffic

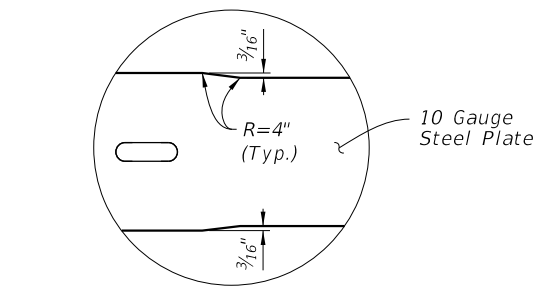

DETAIL "A" (Sleeve Transition Elevation)

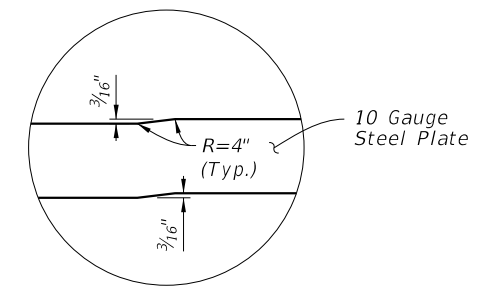

DETAIL "B" (Sleeve Transition Plan)

BENT-PLATE PANEL RUB RAIL

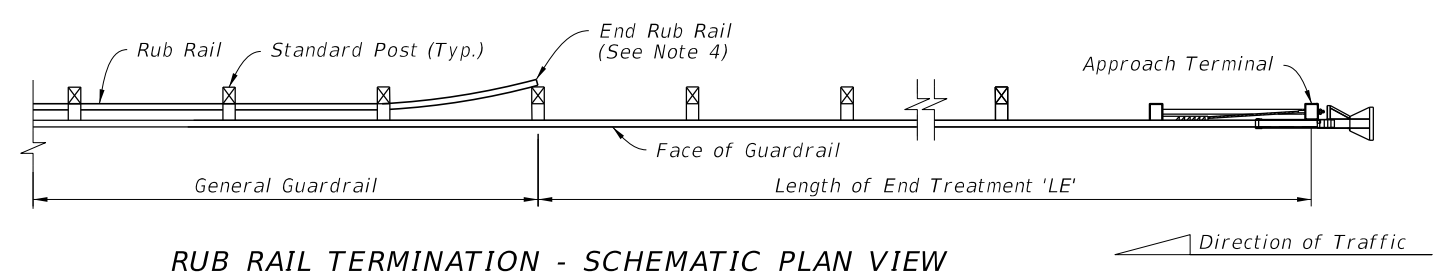

RUB RAIL TERMINATION - SCHEMATIC PLAN VIEW

NOTES:

1. GENERAL: Install Rub Rail where called for in the plans. Position as shown on Sheet 6 unless otherwise shown in the plans. Install the backs of Rub Rail panels flush against Standard Posts. Either of the Channel Section or Bent-Plate Panel Rub Rail options may be used (consistent type per project). Where Double Sided Rub Rail is called for, thread the Button-Head Bolt through the Post Bolt Hole(s) and the panels on either side, and tighten the nut against the face of the panel farthest from adjacent traffic lanes. Trim the bolt's threaded portion in accordance with Note 4 on Sheet 5.
2. MOUNTING HEIGHT: Mount to the Standard Post's Rub Rail Bolt Hole as defined on Sheet 5.
3. MATERIALS: Use steel components in accordance with Specification 967.
4. END RUB RAIL: For Single Sided Rub Rail, terminate the run of Rub Rail by bending the panel behind the post and securing in place (as shown). For Double Sided Rub Rail, terminate the runs of Rub Rail on their respective front face of the post and secure with the typical Button-Head bolt.

RUB RAIL DETAILS

10/20/2022 8:53:22 AM

LAST REVISION 11/01/19	DESCRIPTION:		FY 2023-24 STANDARD PLANS	GUARDRAIL	INDEX	SHEET
					536-001	21 of 24

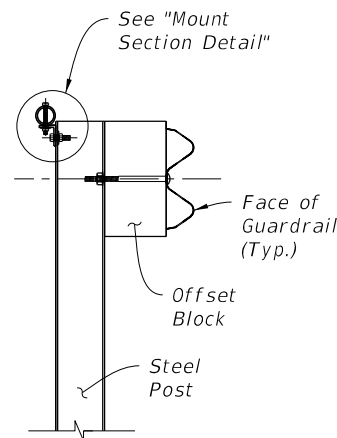

GENERAL PIPE RAIL SECTION

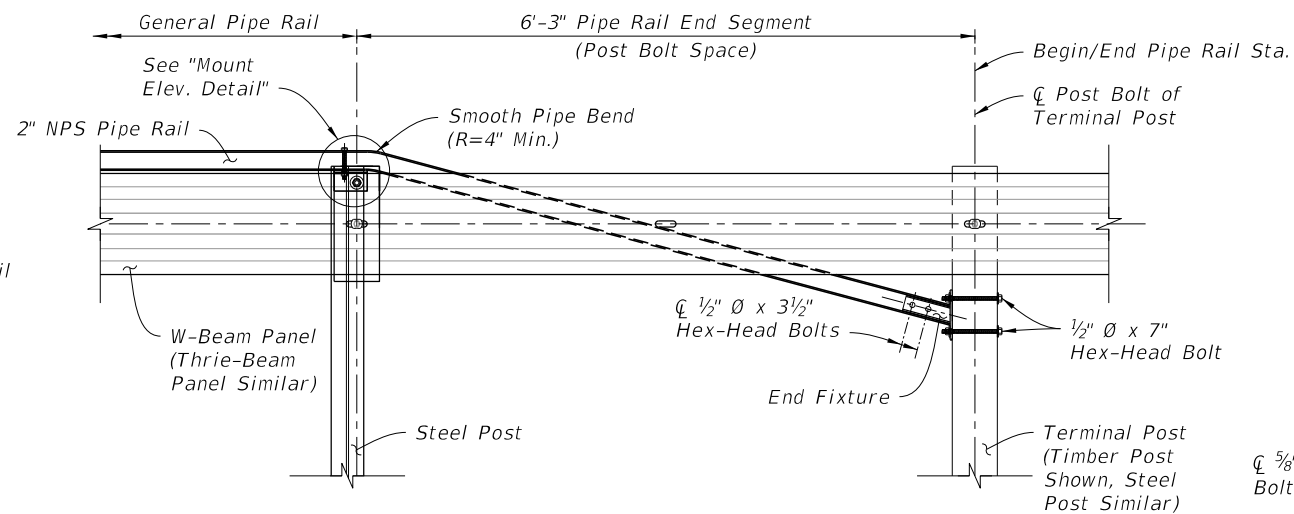

PIPE RAIL INSTALLED ELEVATION (End Segment Shown)

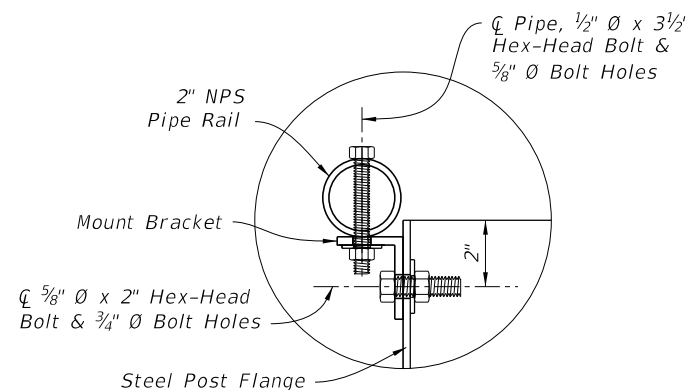

MOUNT SECTION DETAIL

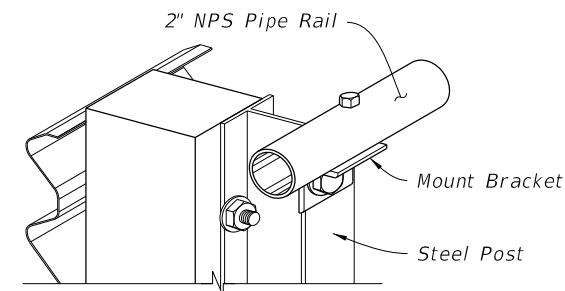

MOUNT ISOMETRIC CUT-AWAY

NOTES:

1. GENERAL: Install General Pipe Rail where indicated in the plans or when existing sidewalks or shared use paths are located less than 4'-0" from the back of Steel Posts as shown on Sheet 6.
2. PIPE RAIL END SEGMENTS: Place End Segments on both ends of General Pipe Rail runs, with End Fixtures mounted to Terminal Posts located outside of Approach Terminal Assembly ('LE'), Trailing Anchorage Assembly ('LT'), and Approach Transition ('LA') segments.
3. MATERIALS: Use steel brackets, fixtures, and pipes in accordance with Specification 967.
4. RAIL SPLICES: Install Rail Splices to join pieces of 2" NPS Pipe Rail into a continuous system. Place splices as needed, at a spacing of 18'-0" or greater. Orient the head of bolt on the top of the pipe.

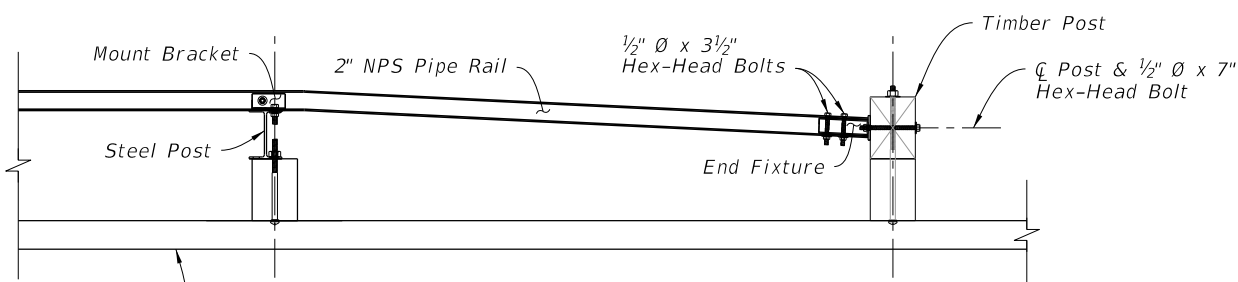

PIPE RAIL INSTALLED PLAN END AT TIMBER POST OPTION

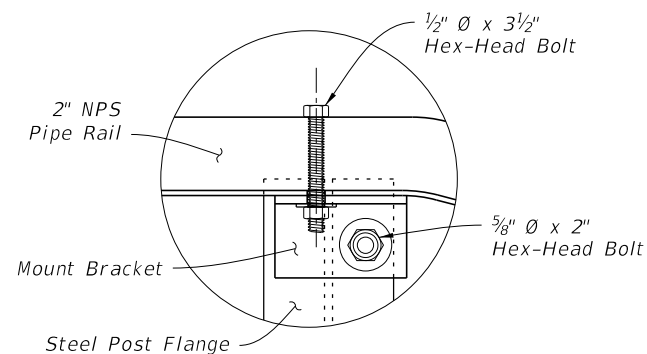

MOUNT ELEVATION DETAIL (Back View - Mirrored)

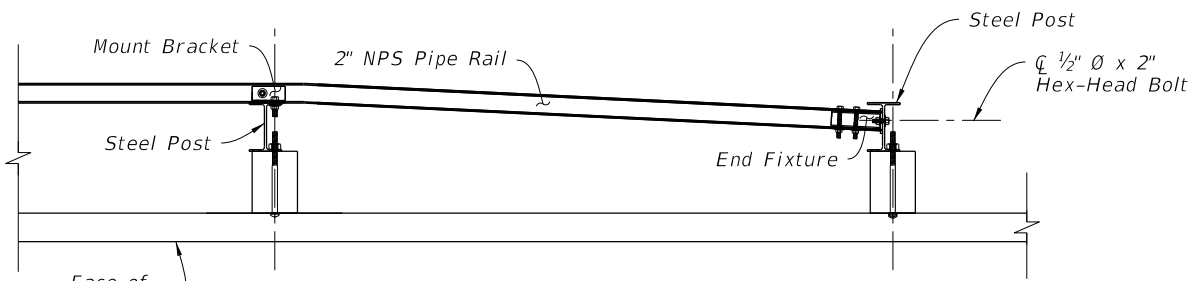

PIPE RAIL INSTALLED PLAN END AT STEEL POST OPTION

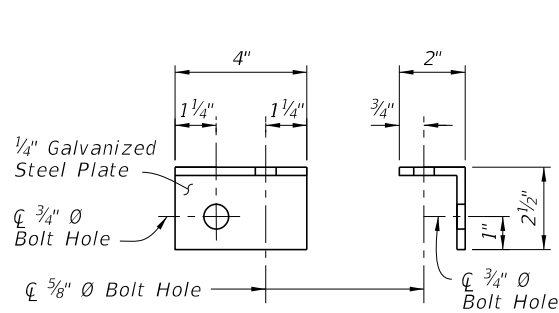

ELEVATION SECTION

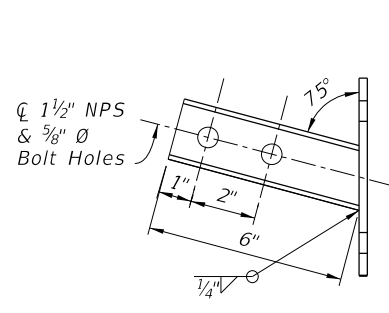

ELEVATION

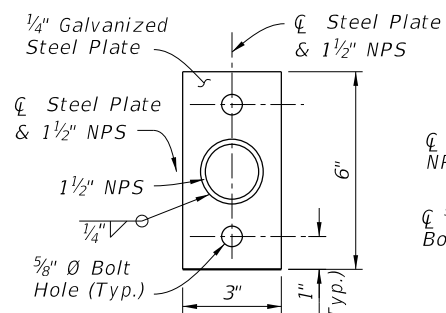

SECTION

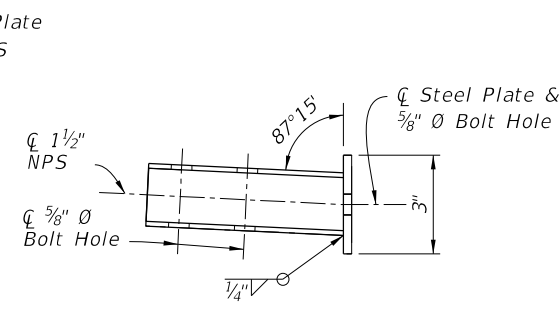

PLAN

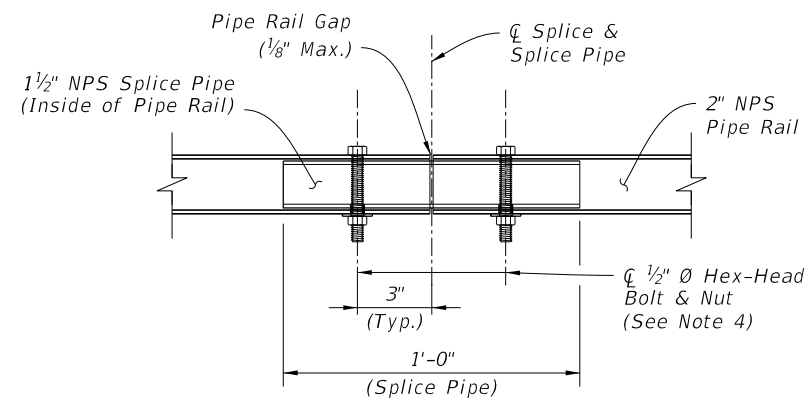

RAIL SPLICE DETAIL

10/20/2022 8:53:23 AM

PEDESTRIAN SAFETY TREATMENT - PIPE RAIL

LAST REVISION 11/01/19	DESCRIPTION:		FY 2023-24 STANDARD PLANS	GUARDRAIL	INDEX	SHEET
						536-001

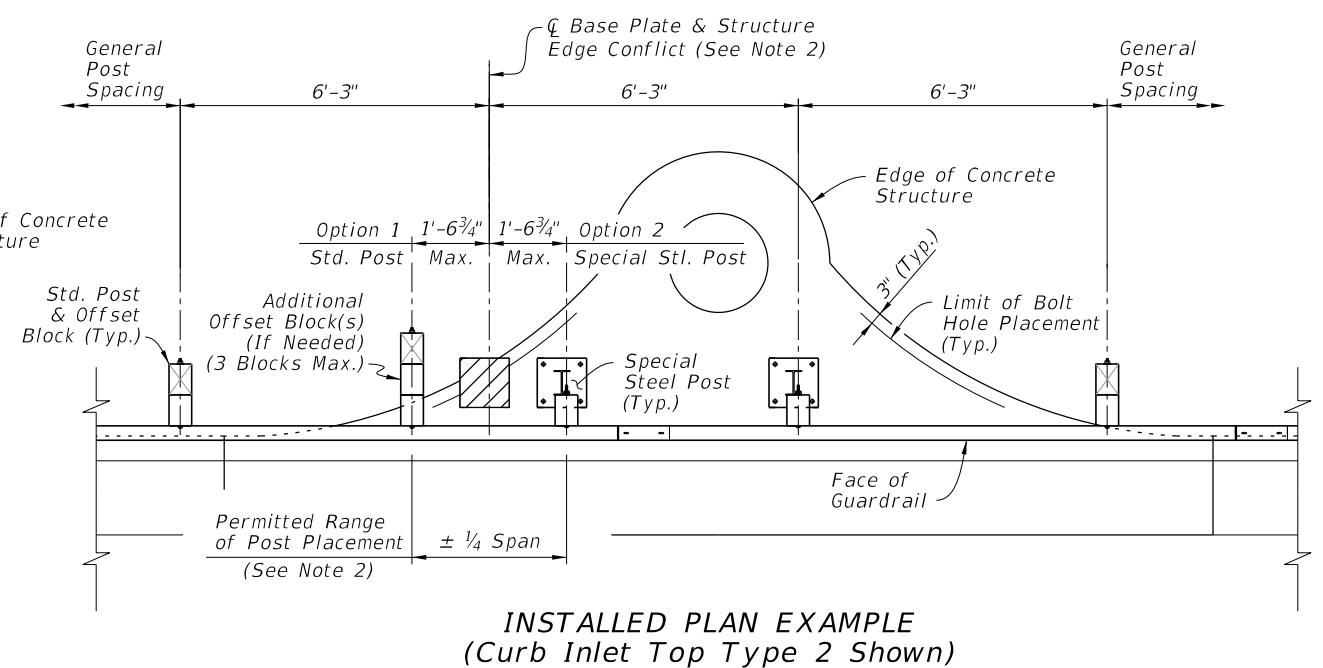
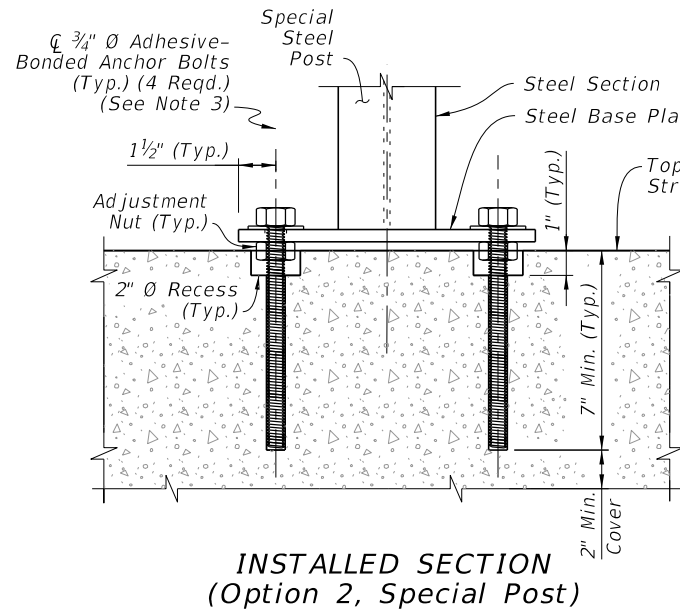
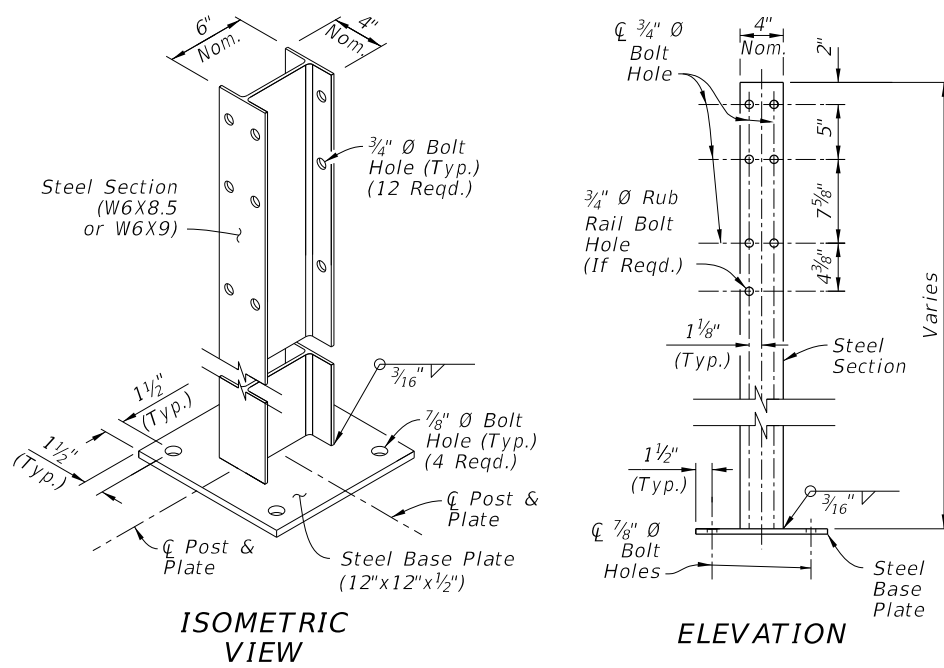

SPECIAL STEEL POST

STRUCTURE MOUNTING

NOTES:

- INSTALLATION:** When the construction of Guardrail at the required post spacing results in post(s) located atop culverts, inlets, pier footings, or similar concrete structures, a Special Steel Post may be substituted for a Standard Post. Install where shown in the plans and/or as-needed, in accordance with Specification 536.
- EDGE CONFLICT:** When a required post location causes an Edge Conflict with the structure, where the Steel Base Plate is not located entirely on the structure at least 3" from the Edge of Concrete, the longitudinal post location may be altered by up to 1'-6 3/4" (Quarter Span) from the original required spacing location to prevent the Edge Conflict. With the post location adjusted, use a Std. Post mounted in soil (Option 1) or a Special Steel Post with its Base Plate mounted entirely on the structure (Option 2). Maintain the original required spacing locations upstream and downstream of the structure.

- BASE PLATE MOUNT:** Install Special Steel Posts as shown using steel Adhesive-Bonded Anchor Bolts in accordance with Specification 536. Use 3/4" Hex-Head Bolts for structures less than 9" deep as defined in the Specification.
- PANEL MOUNT TO ADJUSTED POST:** Punch additional 3/4"x2 1/2" Post Bolt Slot(s) in the W-Beam or Thrie-Beam Panel only where needed to mount the panel to a post in an adjusted location. Meet the Panel Post Bolt Slots requirements of Specification 536.
- MATERIALS:** Use steel base plates in accordance with Specification 536.

SPECIAL STEEL POST FOR CONCRETE STRUCTURE MOUNT

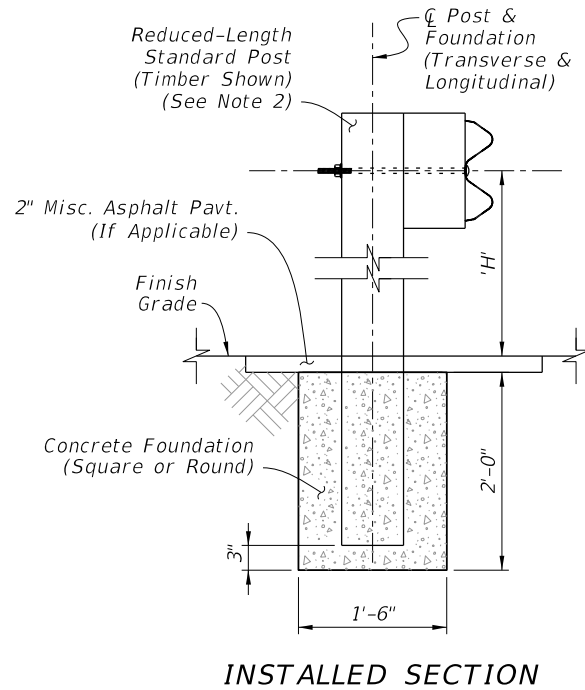

NOTES:

- INSTALLATION:** When the construction of Guardrail at the required post spacing results in post(s) conflicting with underground utilities or other underground obstructions, an Encased Post may be used where a 2'-0" depth will avoid the conflict. Install where shown in the plans and/or as-needed, in accordance with Specification 536.
- REDUCED-LENGTH STANDARD POST:** Use a Standard Post with reduced Length such that the Panel Height 'H' is maintained while the post bottom terminates 3" from the bottom of the Concrete Foundation. Typically, the Post Length 'L' is 4'-7" for W-Beam Guardrail.
- FOUNDATION:** Use non-reinforced Class NS Concrete material in accordance with Specification 347. After casting the concrete, ensure the surrounding soil material is completely backfilled and tamped to provide full passive resistance.
- LIMIT:** Encased Posts are not permitted for more than 3 consecutive posts.

ENCASED POST FOR SHALLOW MOUNT

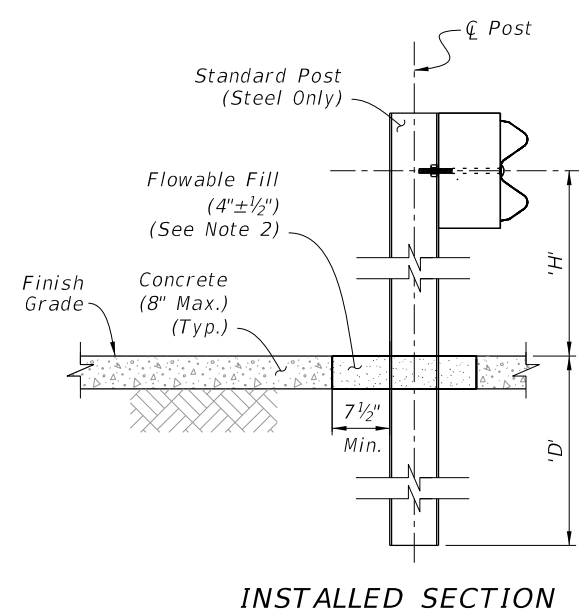

INSTALLED SECTION

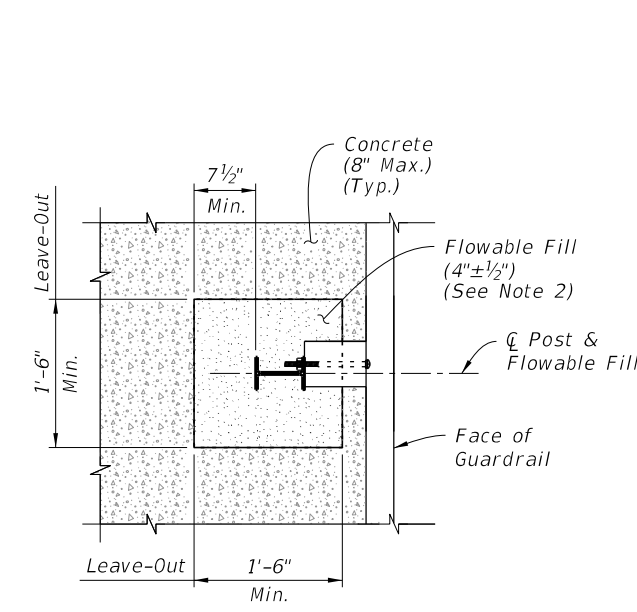

INSTALLED PLAN

NOTES:

- INSTALLATION:** When the construction of Guardrail at the required post spacing results in post(s) placed within a concrete surface (typically a sidewalk), use a Frangible Leave-Out around the post base as shown. Install where shown in the plans and/or as-needed, in accordance with Specification 536.
Use Standard steel posts. Timber posts are not permitted for frangible leave-outs.
For the required 1'-6" x 1'-6" Leave-Out, smoothly cut the existing concrete surface or form-up the square shape when an application has new surrounding concrete.
Ensure Flowable Fill surface is smooth and even with the adjacent concrete surface.
- MATERIALS:** Use Non-Excavatable Flowable Fill in accordance with Specification 121, not to exceed 150 psi.

FRANGIBLE LEAVE-OUT FOR CONCRETE SURFACE MOUNT

12/13/2022 8:36:50 AM

LAST REVISION 11/01/19	DESCRIPTION:		FY 2023-24 STANDARD PLANS	GUARDRAIL	INDEX	SHEET
			536-001		23 of 24	

NOTES:

- INSTALLATION:** Install Barrier Delineators as shown in accordance with the plans, with Specifications 536 and 705, and with the manufacturer's design as approved on the APL.
- MATERIALS:** Use materials of the size and type defined for Barrier Delineators in Specification 993.
- COLOR:** Use either white or yellow retroreflective sheeting to match the color of the nearest lane's edgeline.
- MOUNT LOCATIONS:** Mount Barrier Delineators atop posts as shown, starting with Post (3) of Approach Terminals and incrementally increasing spacing towards the downstream direction. Install the Barrier Delineators at the following spacing:

- S1 = 25' x 1 Space
- S2 = 50' x 1 Space
- S3 = 75' x 1 Space
- S4 = 100' x For the Remaining Run

Additionally, place a Barrier Delineator on Post (2) of the Trailing Anchorage or on the post nearest the Rigid Barrier.

- MEDIAN GUARDRAIL:** Install retroreflective sheeting on both sides of the barrier delineator for Guardrail on medians.

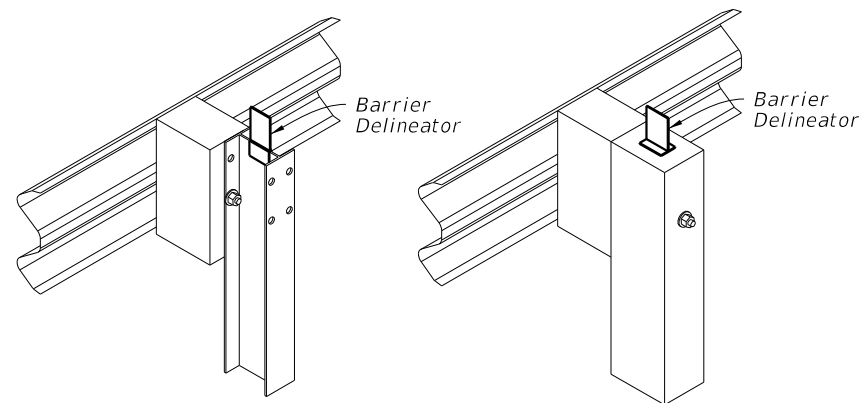

STEEL POSTS TIMBER POSTS

MOUNT LOCATION - ISOMETRIC VIEWS

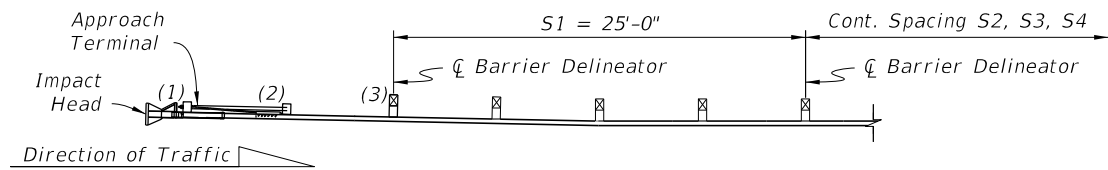

MOUNT LOCATION - PLAN VIEW

BARRIER DELINEATORS

NOTES:

- INSTALLATION:** Work these details with the plans, where Stationing for Begin/End Half Spacing and Begin/End Quarter Spacing are indicated if required.

Where the Begin/End Stations indicated in the plans do not correspond exactly to post locations in construction, extend the Reduced Post Spacing segment to the nearest post(s) before the Begin Station and/or after the End Station called for.

- PANEL SPLICES:** Midspan Panel Splices are not required in Transition and Reduced Post Spacing segments, however they are required for General segments. To place midspan splices in General segments, use one Non-General panel length (9'-4½" or 15'-7½") or add an additional Transition spaced post where required.

- LOW-SPEED GUARDRAIL:** For Reduced Post Spacing with Low-Speed Guardrail (12'-6" post spacing), the Reduced Spacing pattern requires a 6'-3" space between the 12'-6" and 3'-1½" spaces.

- PANEL POST BOLT SLOTS:** For Quarter Spacing configurations, punch additional ¾"x2½" Post Bolt Slots in the panels only where required for mounting and in accordance with Specification 536.

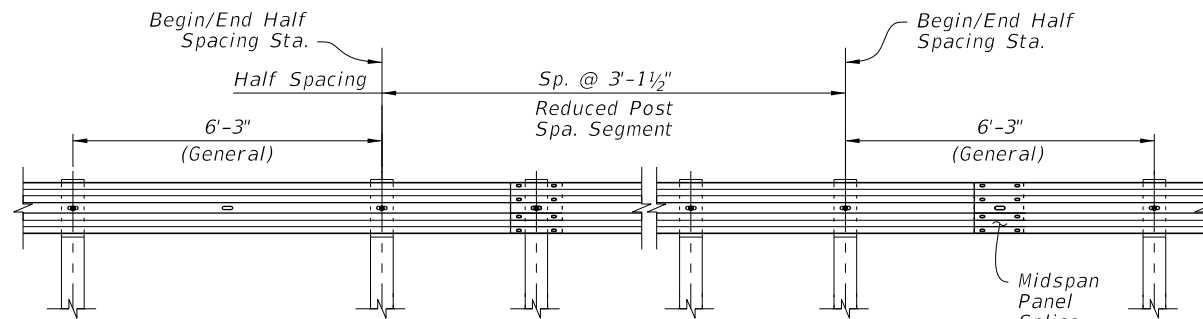

DETAIL 'S' - HALF SPACING ELEVATION
(AS REQD. PER THE PLANS)

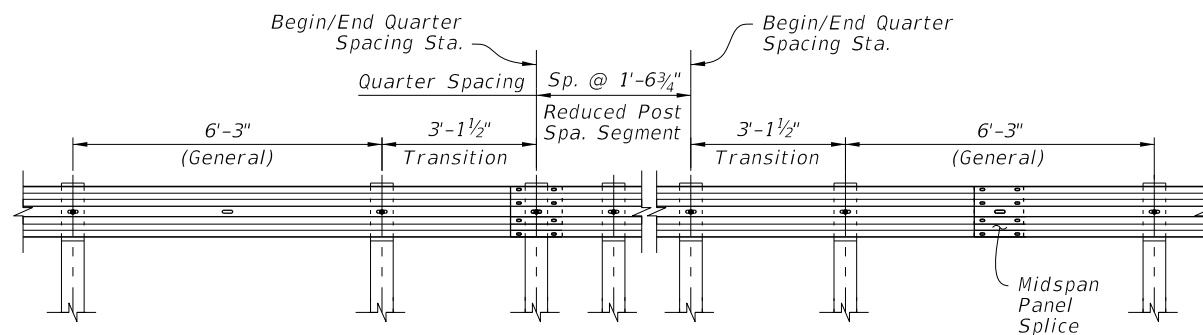

DETAIL 'S' - QUARTER SPACING ELEVATION
(AS REQD. PER THE PLANS)

REDUCED POST SPACING FOR HAZARDS

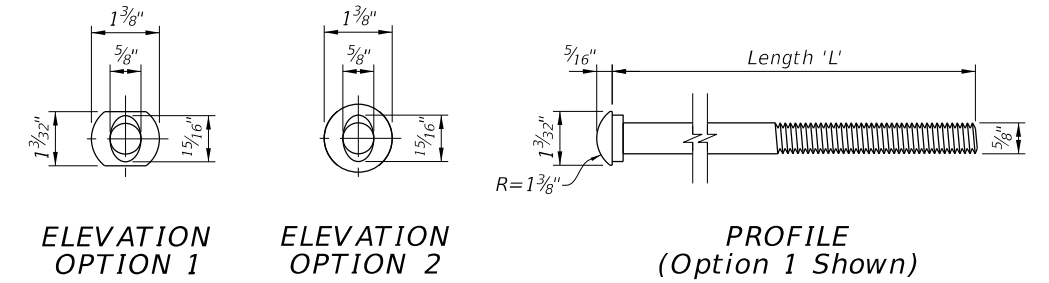

ELEVATION OPTION 1

ELEVATION OPTION 2

PROFILE (Option 1 Shown)

BUTTON-HEAD BOLT

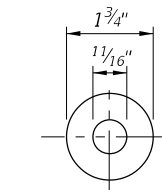

ELEVATION PROFILE

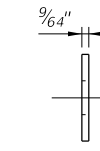

WASHER

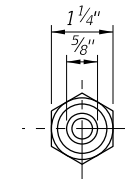

ELEVATION PROFILE

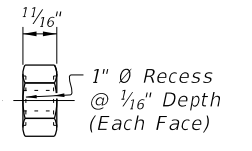

HEX-NUT

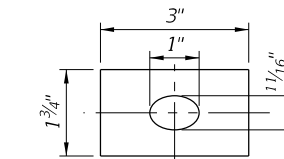

ELEVATION

PROFILE

RECTANGULAR WASHER
(For CRT & Terminal Connectors Where Shown - Install Over Panel Face)

BUTTON-HEAD BOLT LENGTHS:

Application(s):	Length 'L':	Min. Thread Length:
Panel Splice	1¼"	Full Length
Steel Post Mount - Single Faced Guardrail	10"	4"
Timber Post Mount - Single Faced Guardrail	18"	4"
Steel or Timber Post Mount - Double Faced Guardrail	25"	4"

NOTES:

- Use nuts, bolts, and washers in accordance with Specification 967.
- For Steel Posts with Double Faced Guardrail, the single 25" Length bolt (one bolt thru both post flanges) may be replaced with two 10" Length bolts (one bolt per post flange).
- Use bolts listed in Table 2 in corresponding locations shown in this Index.

5/8" BUTTON-HEAD BOLT

12/13/2022 8:36:51 AM

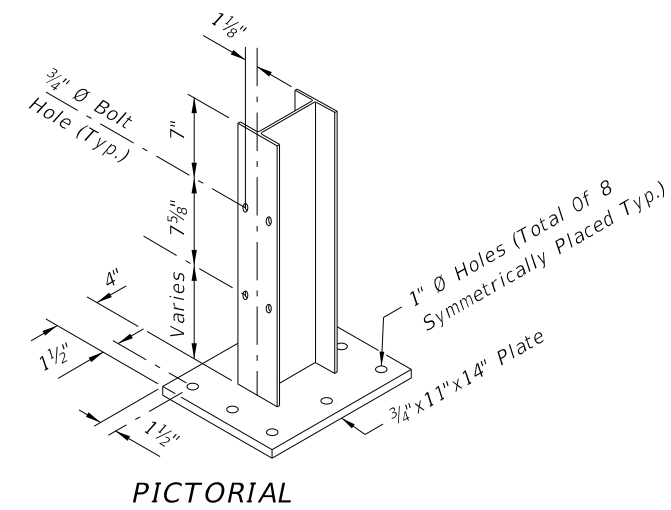

PICTORIAL

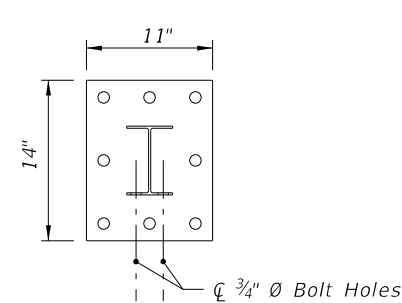

TOP VIEW

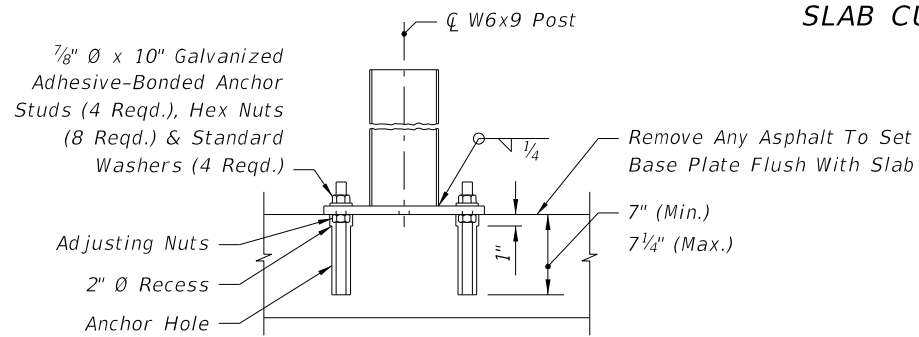

SIDE VIEW

SPECIAL STEEL POST FOR ROADWAY THRIE-BEAM TRANSITIONS TO BRIDGE TRAFFIC RAILING RETROFITS

CURB TYPE F FLARE WHEN END OF EXISTING APPROACH SLAB CURB EXPOSED

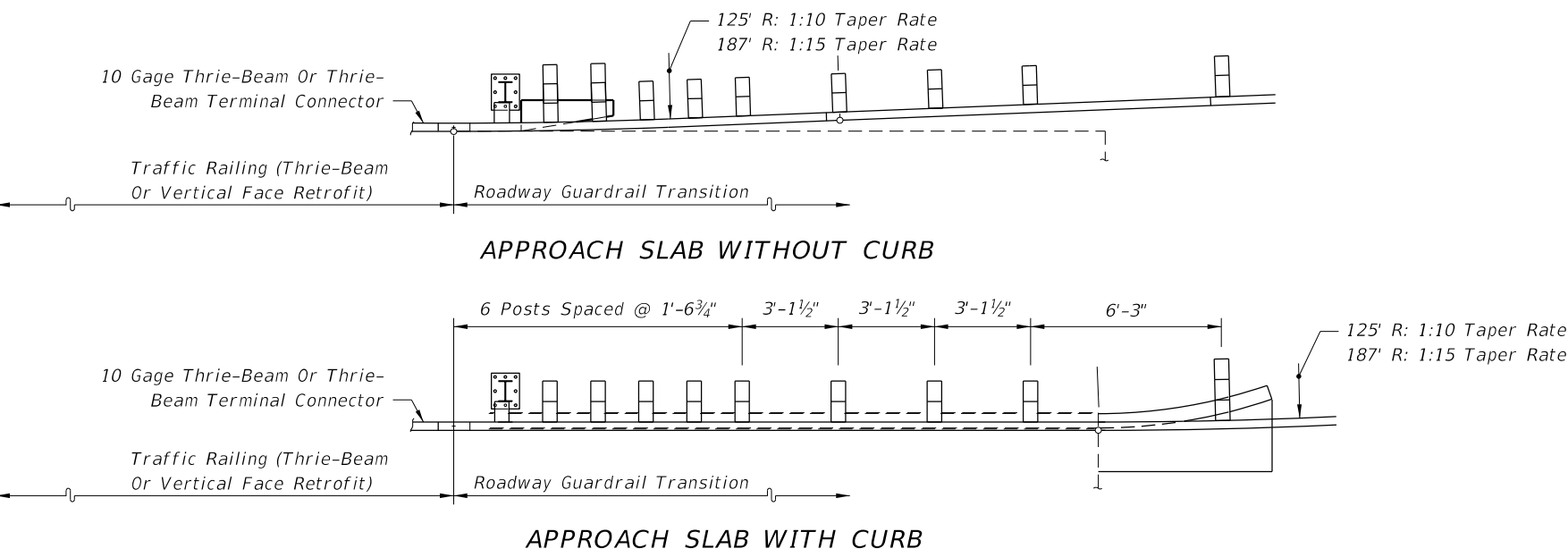
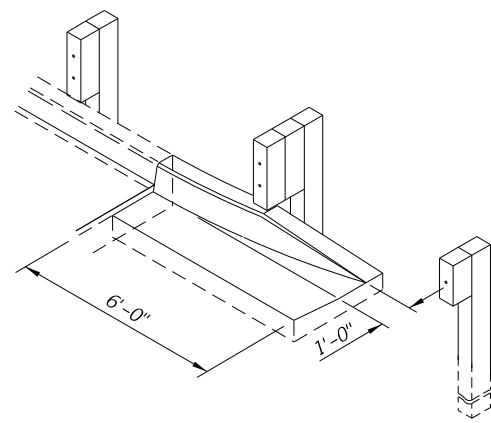

APPROACH SLAB WITH CURB

Longitudinal Location Of Transition Blocks And Curb End Flares Will Vary With Scheme Type

PARTIAL PLAN VIEWS

GUARDRAIL TRANSITION ALIGNMENTS FOR BRIDGE THRIE-BEAM AND VERTICAL FACE TRAFFIC RAILING RETROFIT

GENERAL NOTES

1. This index provides guardrail transition details for approach and trailing end guardrail connections to existing bridges, including details for connecting to traffic railing retrofits and safety shape barriers on existing bridges. Sheets 1 through 26 apply to bridges with retrofitted traffic railings (Sheet 26 shows the trailing end guardrail connections). Sheets 27 and 28 apply to bridges with safety shape traffic railing, and they provide approach and trailing end transition connection details for guardrail. Construct these guardrail transitions and connections where called for in the plans.
2. For miscellaneous guardrail components and construction details that are not provided in this Index, refer to Index 536-001.

NOTES FOR GUARDRAIL TRANSITIONS CONNECTING TO TRAFFIC RAILING RETROFITS ON EXISTING BRIDGES

1. The transition detail shown on this sheet shows (a) the standard post spacings within the typical thrie-beam approach transitions connecting to existing bridges with retrofit traffic railings, and (b) depict the typical alignments of the approach transitions.
2. The curb and gutter flare shown on this sheet is typical of flares that are to be constructed when approach slab curbs extend to the beginning of the slab, and where other treatment to curb blunt ends are not in place.
3. The special steel post for roadway thrie-beam transitions detailed on this sheet is specific to all transition applications on this index that require one or more steel posts.

The special steel post and base plate assembly shall be fabricated in accordance with Specification 967.

Anchor studs shall be fully threaded rods in accordance with ASTM F1554 Grade 36 or ASTM A193 Grade B7. All nuts shall be heavy hex in accordance with ASTM A563 or ASTM A19

4. Anchor studs and nuts shall be hot-dip zinc coated in accordance with the Specifications. After the nuts have been snug tightened, the anchor stud threads shall be single punch distorted immediately above the top nuts to prevent loosening of the nuts. Distorted threads shall be coated with a galvanizing compound in accordance with the Specifications.

Adhesive bonding material systems for anchors shall comply with Specification 937 and be installed in accordance with Specification 416.4. Nested beam extensions and points for terminal connector attachments will vary for traffic railing barrier vertical face retrofits. The plan views for the vertical face retrofit barriers show the primary configurations for each particular scheme. The associated pictorial views show the variations.

5. For installing thrie-beam terminal connector to traffic railing vertical face retrofits, see notations on Sheets 15 through 18 and the flag notation on Sheet 26.

10/20/2022 8:53:27 AM

LAST REVISION 11/01/19	REVISION	DESCRIPTION:		FY 2023-24 STANDARD PLANS	GUARDRAIL TRANSITIONS AND CONNECTIONS FOR EXISTING BRIDGES	INDEX 536-002	SHEET 1 of 28
---------------------------	----------	--------------	---	------------------------------	---	------------------	------------------

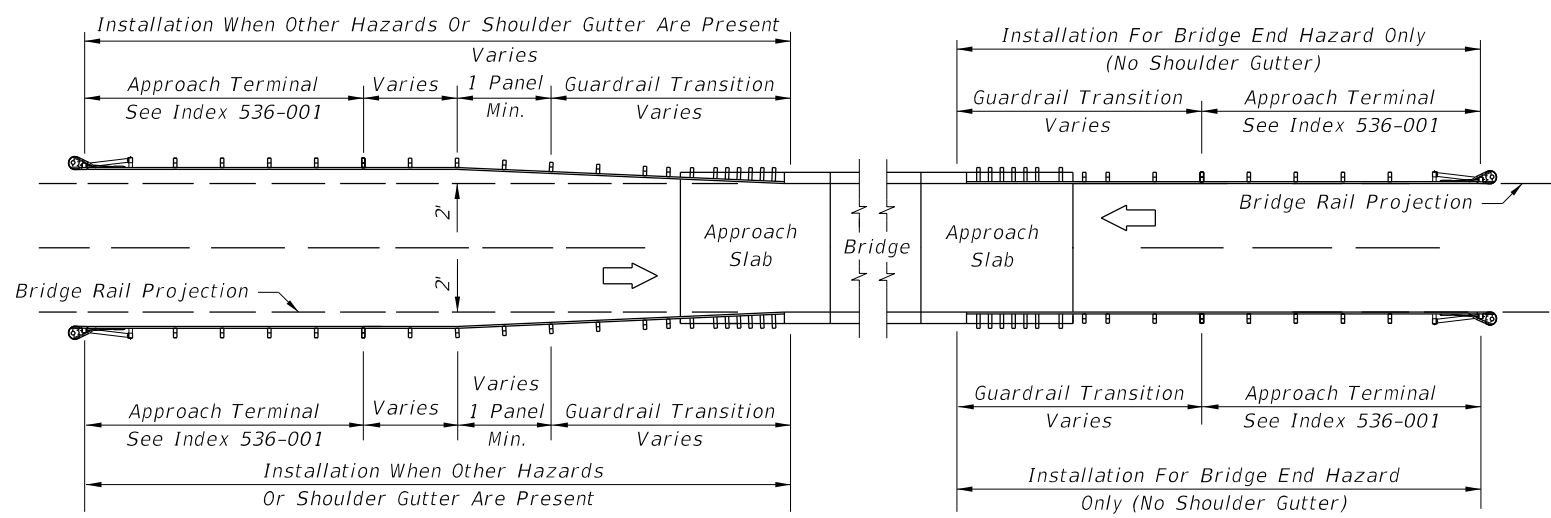

UNDIVIDED ROADWAY - DETAIL H

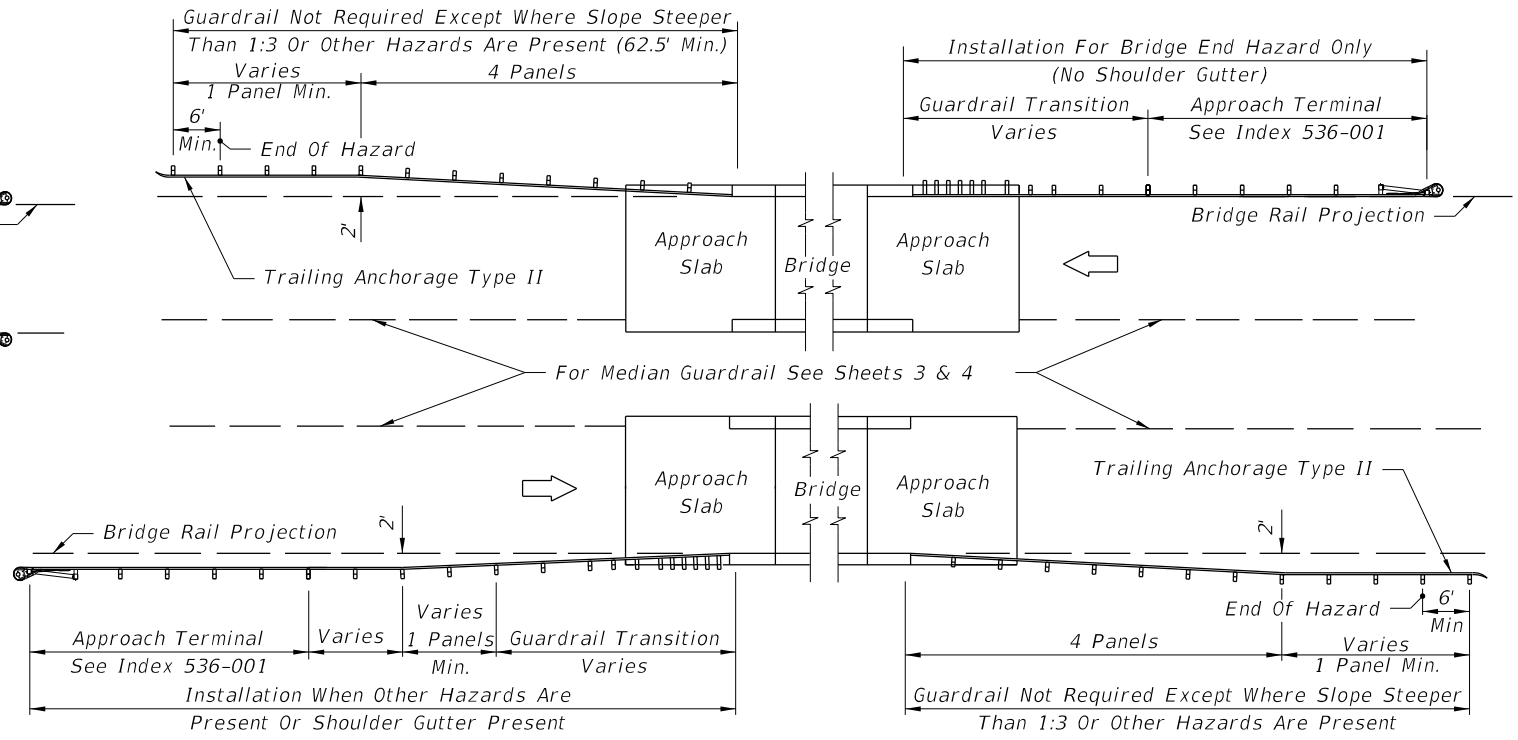

DIVIDED ROADWAY - DETAIL I

GUARDRAIL APPLICATIONS FOR BRIDGES WITH FULL WIDTH SHOULDERS AND SAFETY SHAPE TRAFFIC RAILING BARRIER EXTENDING LESS THAN FULL APPROACH SLAB LENGTH

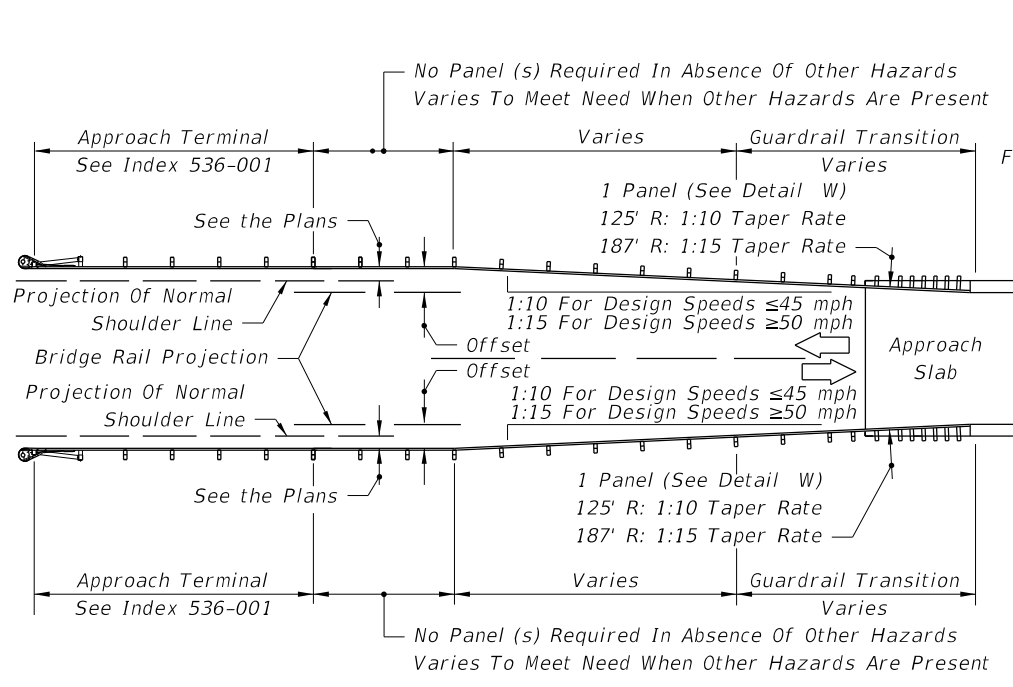

UNDIVIDED ROADWAY - DETAIL S

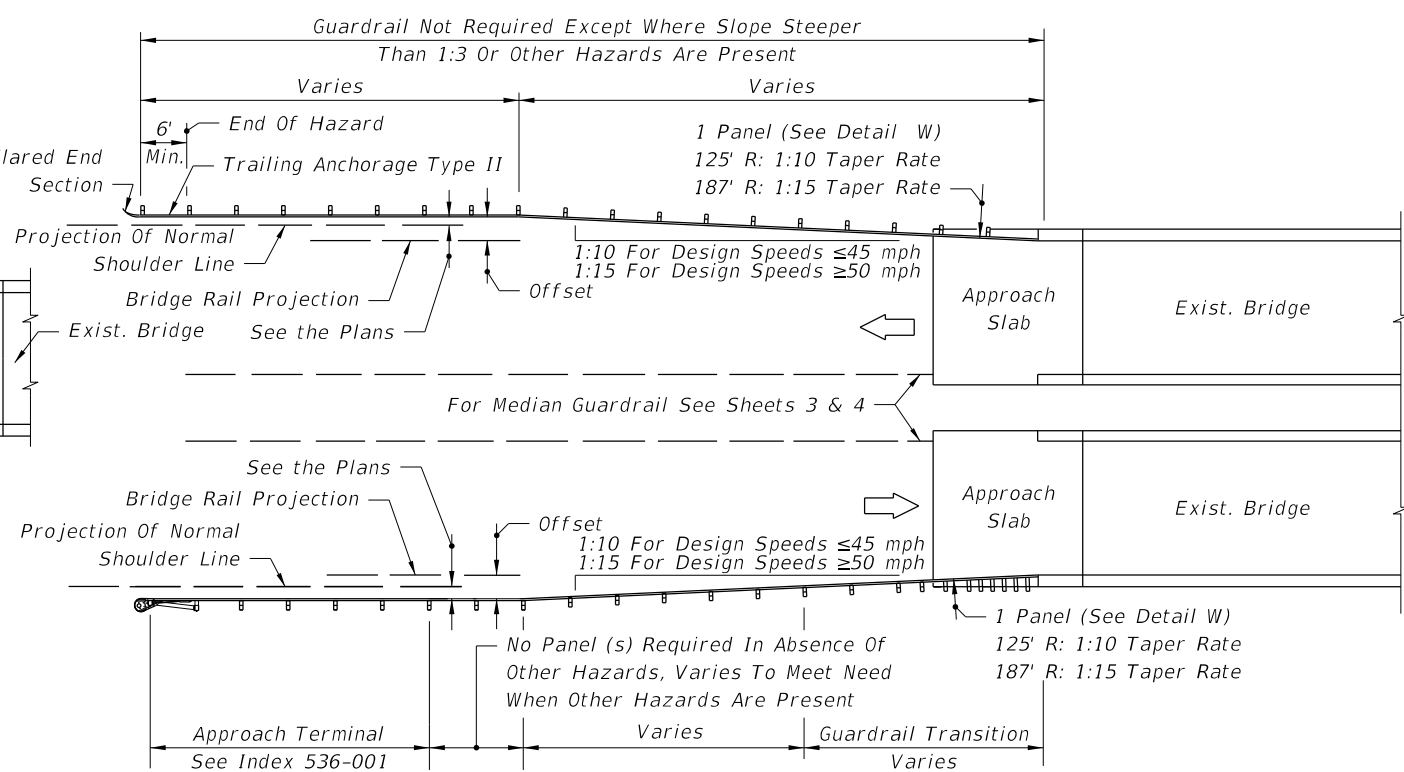

DIVIDED ROADWAY - DETAIL T

GUARDRAIL APPLICATIONS FOR BRIDGES WITH LESS THAN FULL WIDTH SHOULDERS AND CONCRETE TRAFFIC RAILING EXTENDING LESS THAN FULL APPROACH SLAB LENGTH

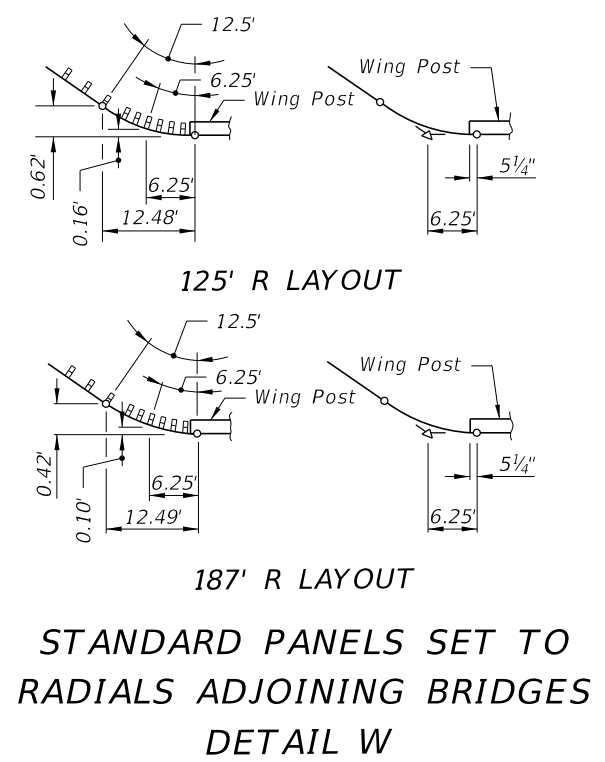

10/20/2022 8:53:28 AM

LAST REVISION 11/01/19	DESCRIPTION:	FDOT	FY 2023-24 STANDARD PLANS	GUARDRAIL TRANSITIONS AND CONNECTIONS FOR EXISTING BRIDGES	INDEX 536-002	SHEET 2 of 28
---------------------------	--------------	------	------------------------------	---	------------------	------------------

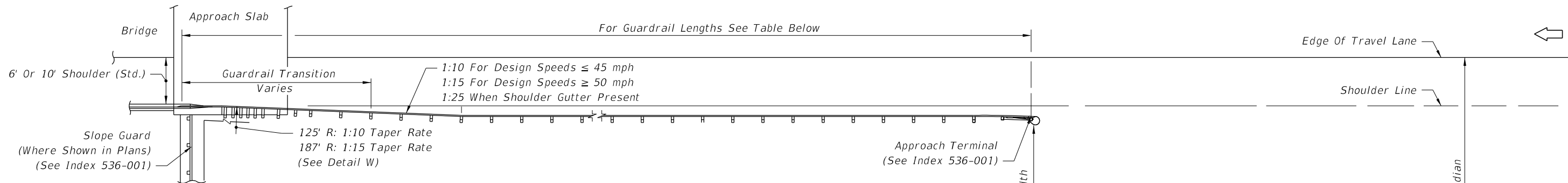

GUARDRAIL LENGTH (Ft.)						
Design Speed (mph)	Projected ADT	CZ (Ft.)	6' & 8' Rdwy. Shldr.		10' & 12' Rdwy. Shldr.	
			Min. Median Width	Guardrail Length	Min. Median Width	Guardrail Length
60-70	≥ 1500	36	50	362.5	54	312.5
60-70	< 1500	30	44	287.5	48	237.5
55	≥ 1500	30	44	287.5	48	237.5
55	< 1500	24	38	212.5	42	162.5
45-50	≥ 1500	24	38	212.5	42	162.5
45-50	< 1500	20	34	162.5	38	112.5
45-50	Urban w/o Curb	24	38	212.5	42	162.5
35-40	Urban w/o Curb	18	32	162.5	36	100.0

Notes:
 Lengths shown in the tables are based on Length of Advancement design and consider minimum median widths and clear zone widths for opposing travel lanes. Length of Advancement values are intended to better match existing conditions and layouts. Where a designer chooses to use the newer Length of Need process, the lengths shown in the tables may be superseded as detailed in the Plans. Lengths may also require adjustment for connection location on wing post or bridge traffic railing barrier, auxiliary lanes, skewed crossings, and other hazards if present.

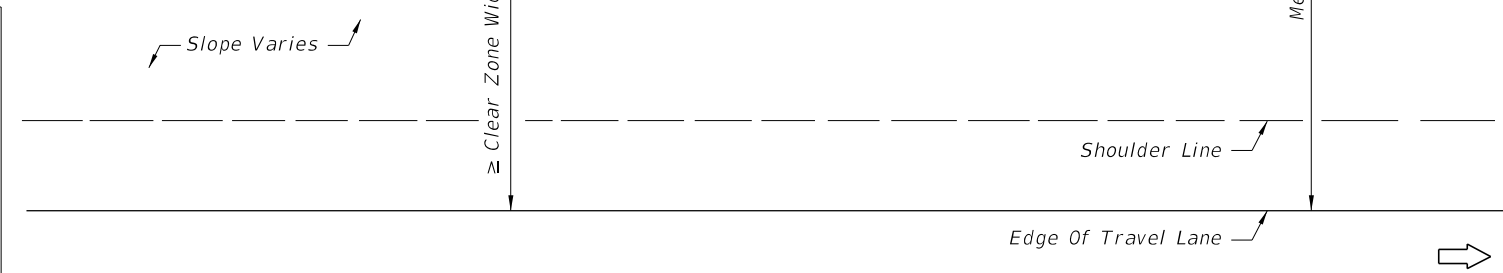

Note: For Approach Terminals, see sheets elsewhere in this Index and the plans.

WHEN END TERMINAL IS OUTSIDE OF OPPOSING ROADWAY CLEAR ZONE

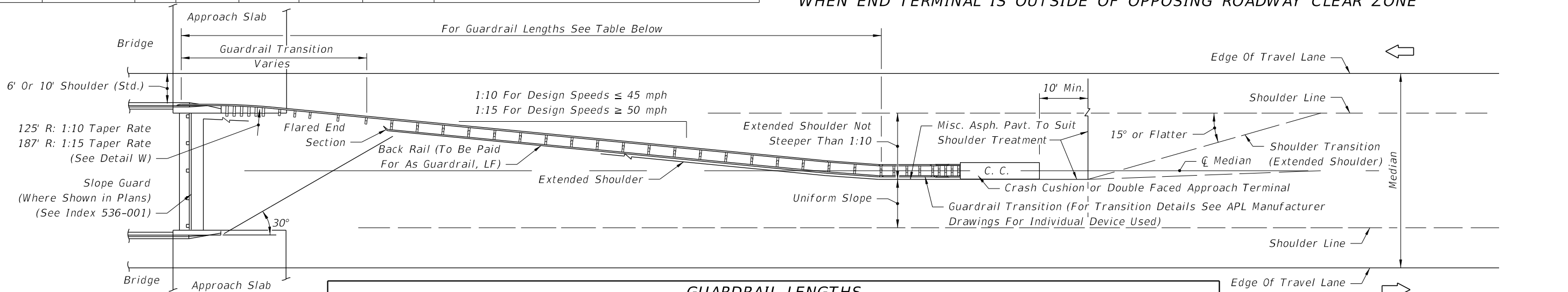

GUARDRAIL LENGTHS																
Median Width (ft.)	1:10 TAPER RATE								1:15 TAPER RATE							
	6' Bridge Shoulder				10' Bridge Shoulder				6' Bridge Shoulder				10' Bridge Shoulder			
	Panels (No.)		Length (Ft.)		Panels (No.)		Length (Ft.)		Panels (No.)		Length (Ft.)		Panels (No.)		Length (Ft.)	
	Front	Back	Total	Total	Front	Back	Total	Total	Front	Back	Total	Total	Front	Back	Total	Total
32	7.5	6	13.5	168.75	4.5	3	7.5	93.75	11.5	9	20.5	256.25	7.5	6	13.5	168.75
34	8.5	6	14.5	181.25	5.5	4	9.5	118.75	12.5	10	22.5	281.25	7.5	6	13.5	168.75
36	9.5	7	16.5	206.25	6.5	5	11.5	143.75	13.5	11	24.5	306.25	8.5	7	15.5	193.75
38	10.5	8	18.5	231.25	7.5	6	13.5	168.75	14.5	12	26.5	331.25	10.5	9	19.5	243.75
40	10.5	8	18.5	231.25	7.5	6	13.5	168.75	16.5	13	29.5	368.75	11.5	9	20.5	256.25
42	11.5	8	19.5	243.75	8.5	6	14.5	181.25	17.5	14	31.5	393.75	12.5	10	22.5	281.25
44	12.5	9	21.5	268.75	9.5	7	16.5	206.25	18.5	15	33.5	418.75	13.5	11	24.5	306.25
46	12.5	9	21.5	268.75	10.5	8	18.5	231.25	19.5	16	35.5	443.75	14.5	12	26.5	331.25
48	14.5	11	25.5	318.75	11.5	9	20.5	256.25	20.5	16	36.5	456.25	16.5	13	29.5	368.75

The lengths shown on this table are typical for roadways with standard width shoulders and a relocated connection to the existing wing post. Length requirements shall be determined on a site specific basis for both standard width and narrow bridge shoulders and for end anchorage or end shielding use. See design notes in above table.

WHEN END TERMINAL CANNOT BE LOCATED OUTSIDE OF OPPOSING ROADWAY CLEAR ZONE

**APPROACH GUARDRAIL TREATMENTS FOR BRIDGES WITH CONCRETE TRAFFIC RAILING
 EXTENDING LESS THAN FULL APPROACH SLAB LENGTH IN WIDE MEDIANS WITH FLUSH SHOULDERS**

10/20/2022 8:53:29 AM

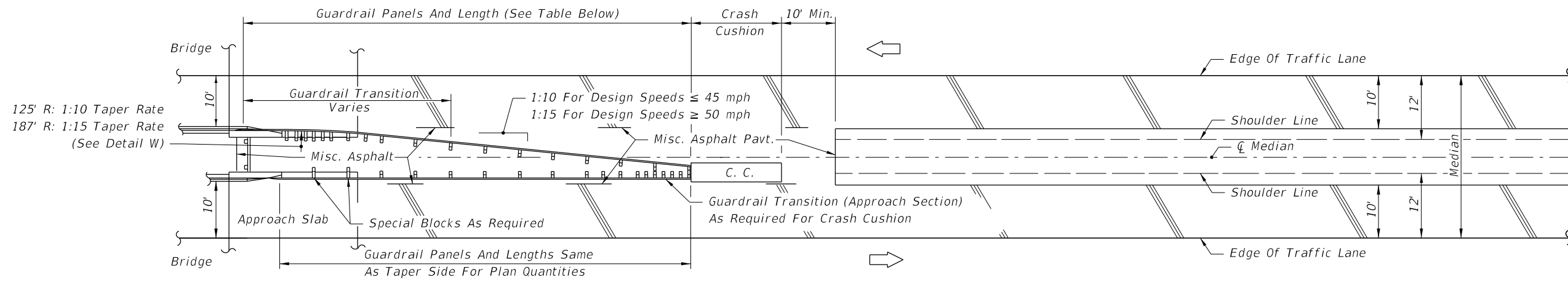

MEDIANS WITH 10' BRIDGE SHOULDERS

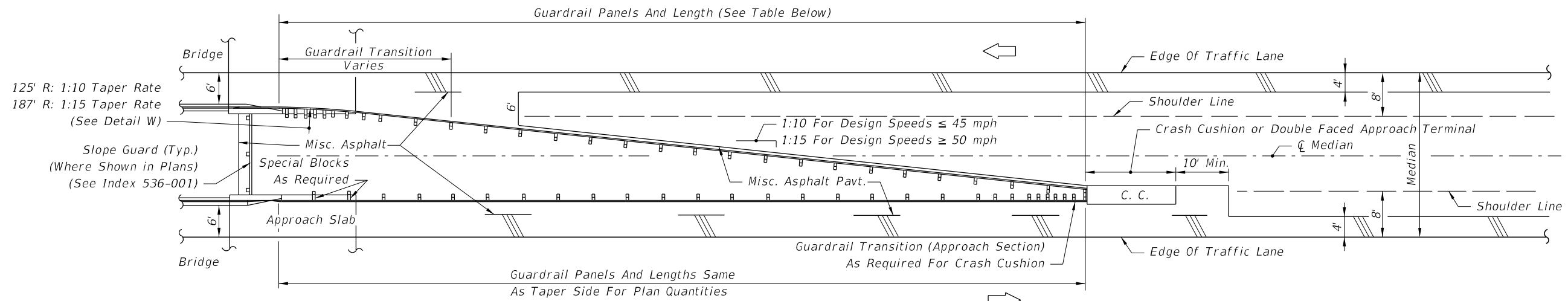

MEDIANS WITH 6' BRIDGE SHOULDERS

Note: The guardrail configurations shown apply only to parallel or near parallel bridges with open medians.

GUARDRAIL LENGTHS								
MEDIAN WIDTH (Ft.)	6' BRIDGE SHOULDERS				10' BRIDGE SHOULDERS			
	1:10 TAPER RATE		1:15 TAPER RATE		1:10 TAPER RATE		1:15 TAPER RATE	
	PANELS (No.)	LENGTH (Ft.)	PANELS (No.)	LENGTH (Ft.)	PANELS (No.)	LENGTH (Ft.)	PANELS (No.)	LENGTH (Ft.)
30	12.5	156.25	18.5	231.25	6.5	81.25	9.5	118.75
28	11.5	143.75	16.5	206.25	5.5	68.75	7.5	93.75
26	9.5	118.75	14.5	181.25	5.5*	68.75	5.5*	68.75
24	8.5	106.25	11.5	143.75	5.5*	68.75	5.5*	68.75

The lengths shown in this table are based on standard widths for roadway and bridge median shoulders. Length requirements for both standard width and narrow bridge shoulders and end anchorage or end shielding requirements shall be determined on a site specific basis. The number of panels may be reduced when installing a crash cushion more than 2.5' in width; see * below.

*Number shown is the minimum number of panels plus a W-Three beam transition panel; single faced guardrail must have a length of five (5) or more panels.

**APPROACH GUARDRAIL TREATMENTS FOR BRIDGES WITH CONCRETE TRAFFIC RAILING
EXTENDING LESS THAN FULL APPROACH SLAB LENGTH IN NARROW MEDIANS WITH FLUSH SHOULDERS**

10/20/2022 8:53:30 AM

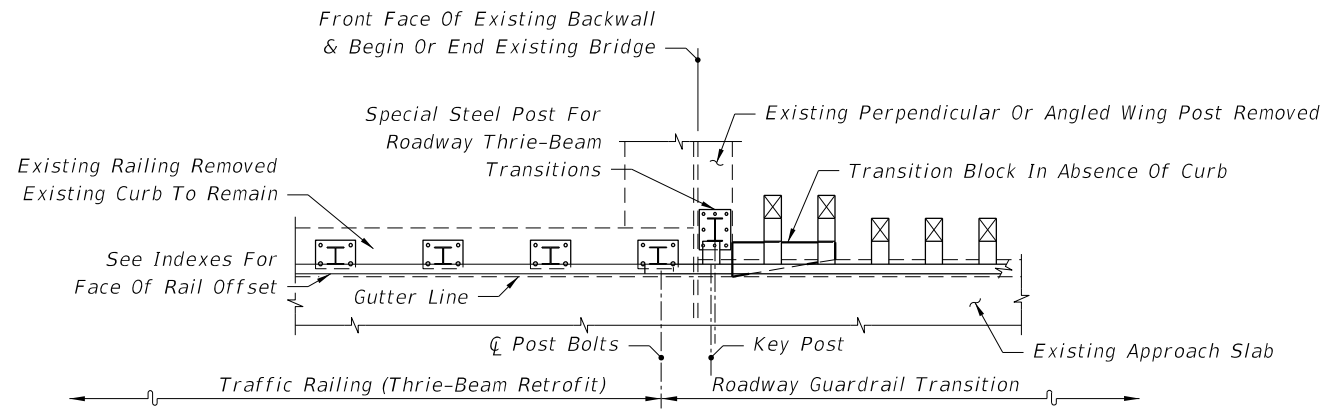

SEE INDEX 460-471 - SCHEME 1

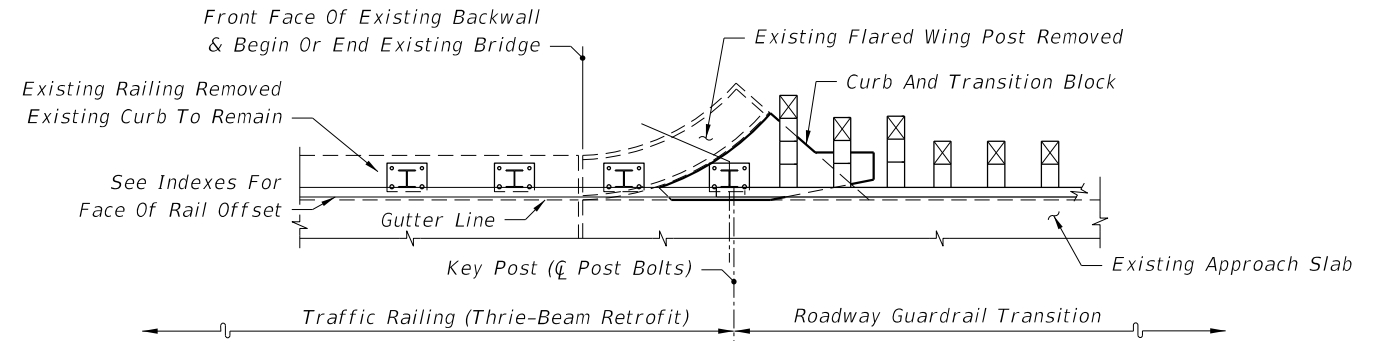

SEE INDEX 460-471 - SCHEME 3

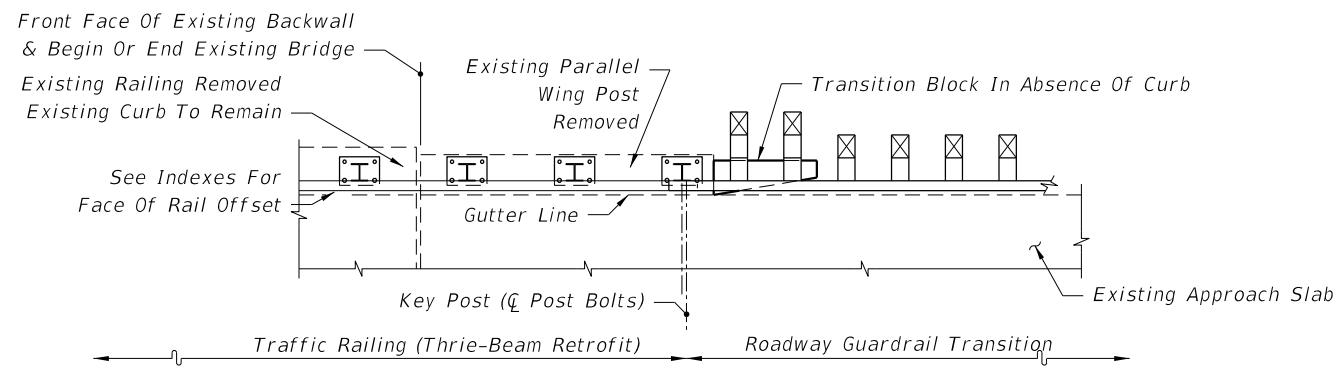

SEE INDEX 460-471 - SCHEME 2

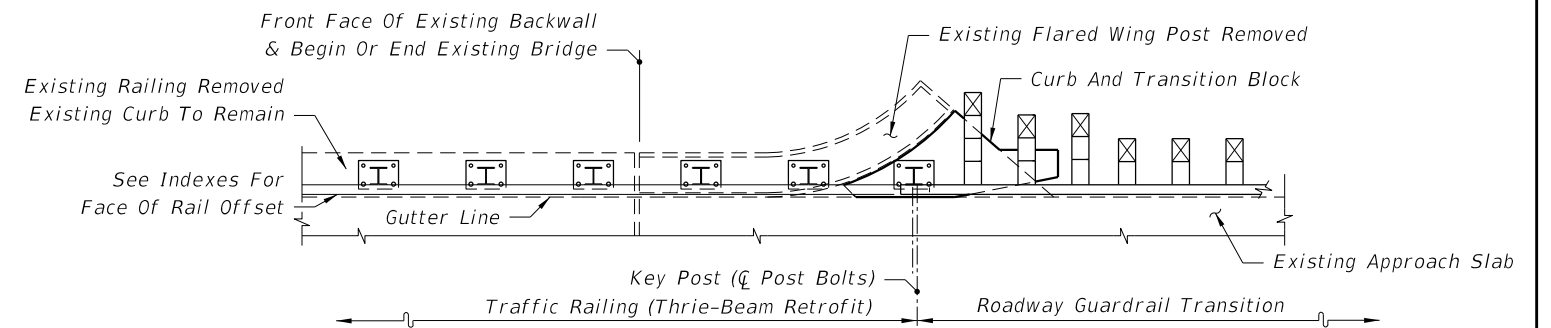

SEE INDEX 460-471 - SCHEME 3

PARTIAL PLAN VIEWS OF GUARDRAIL APPROACH TRANSITIONS AND CONNECTIONS
FOR BRIDGE TRAFFIC RAILING (THRIE-BEAM RETROFIT)

10/20/2022 8:53:31 AM

LAST REVISION 11/01/19	REVISION	DESCRIPTION:	 FY 2023-24 STANDARD PLANS	GUARDRAIL TRANSITIONS AND CONNECTIONS FOR EXISTING BRIDGES	INDEX 536-002	SHEET 5 of 28
---------------------------	----------	--------------	---	---	------------------	------------------

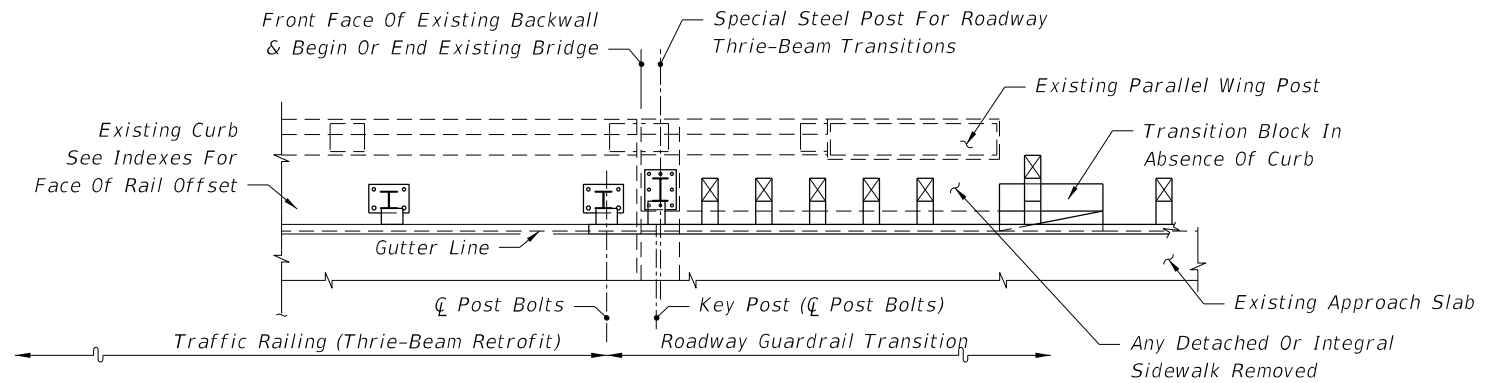

SEE INDEXES 460-472 & 460-475 - SCHEME 2

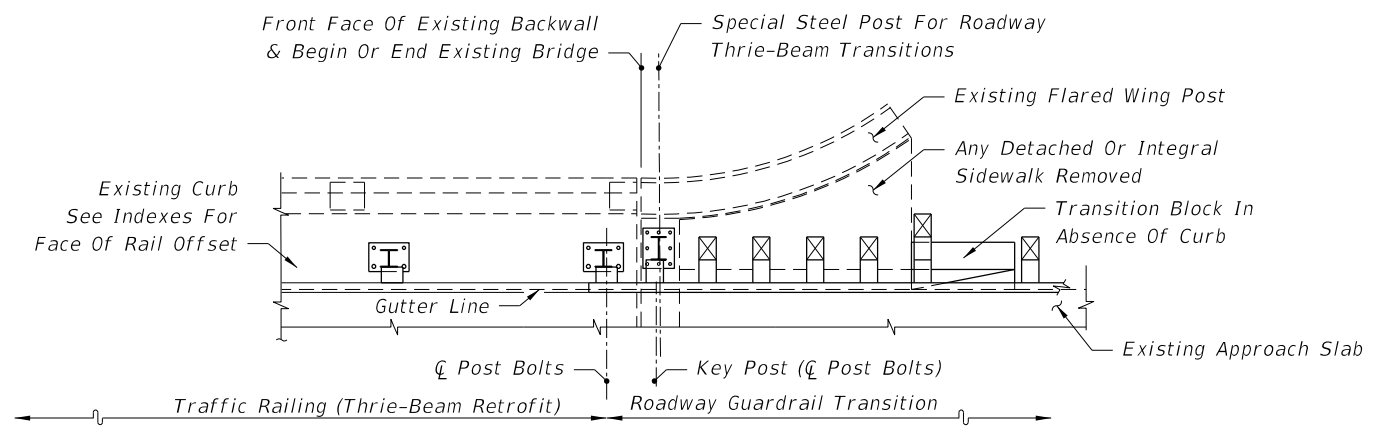

SEE INDEXES 460-472 & 460-475 - SCHEME 2

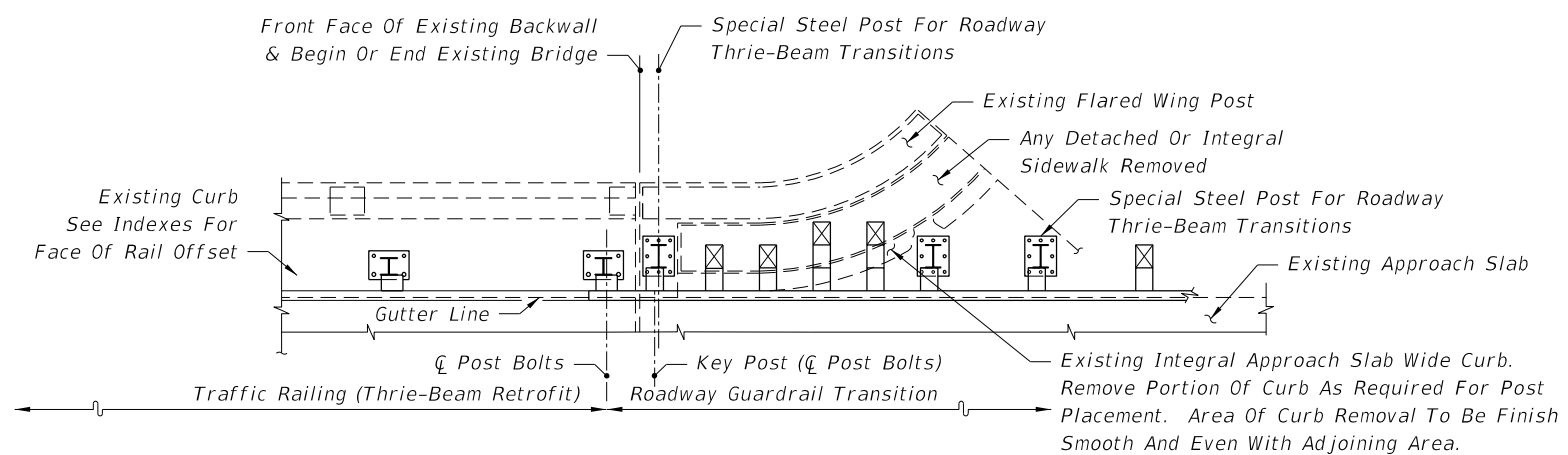

SEE INDEXES 460-472 & 460-475 - SCHEME 2

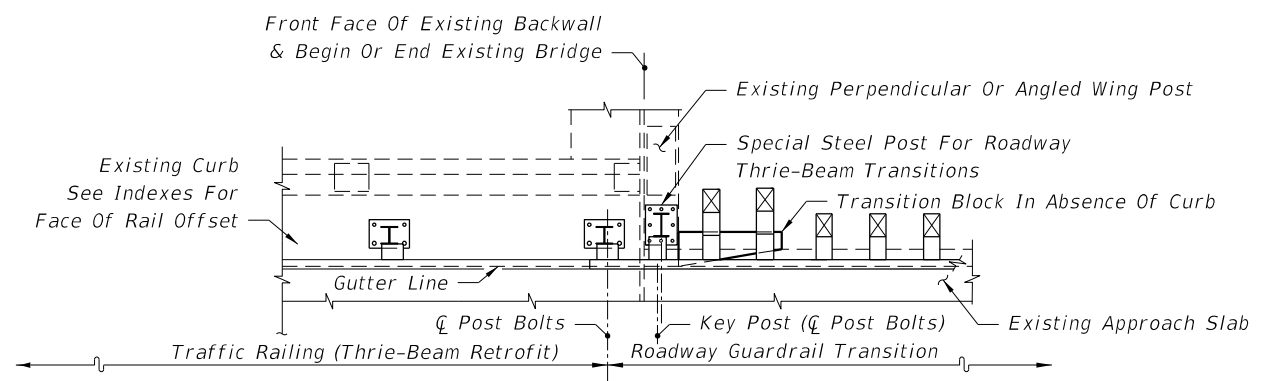

SEE INDEXES 460-472 & 460-475 - SCHEME 1

PARTIAL PLAN VIEWS OF GUARDRAIL APPROACH TRANSITIONS AND CONNECTIONS FOR BRIDGE TRAFFIC RAILING (THRIE-BEAM RETROFIT)

10/20/2022 8:53:32 AM

LAST REVISION 11/01/19	REVISION	DESCRIPTION:	 FY 2023-24 STANDARD PLANS	GUARDRAIL TRANSITIONS AND CONNECTIONS FOR EXISTING BRIDGES	INDEX 536-002	SHEET 6 of 28
---------------------------	----------	--------------	--	---	------------------	------------------

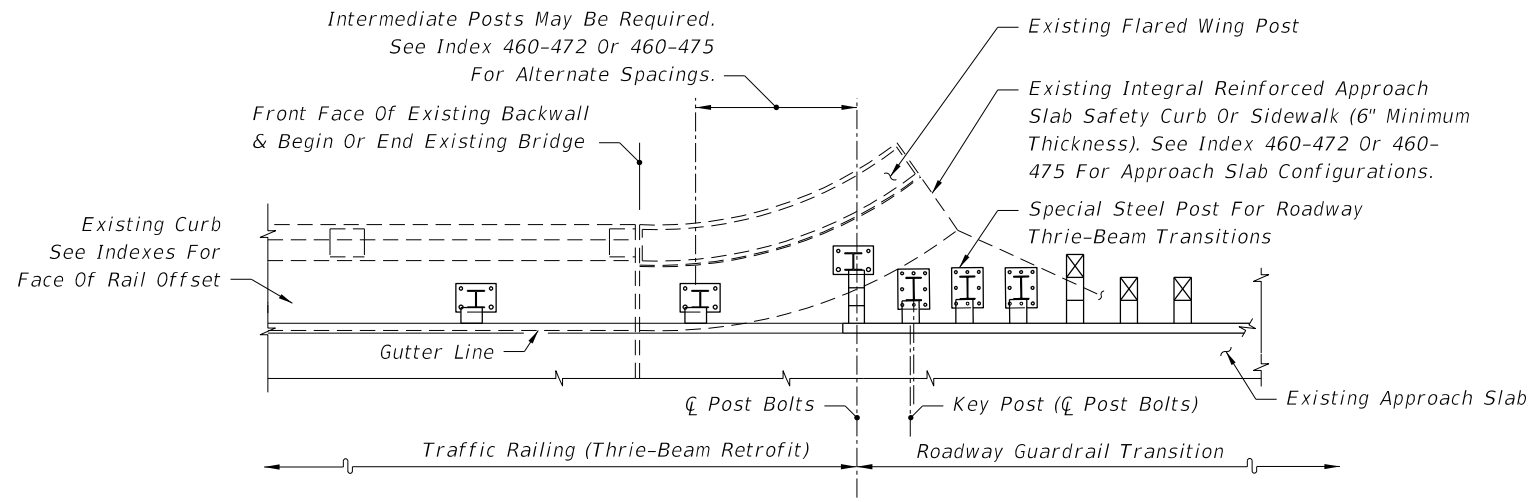

SEE INDEXES 460-472 & 460-475 - SCHEMES 3 & 4

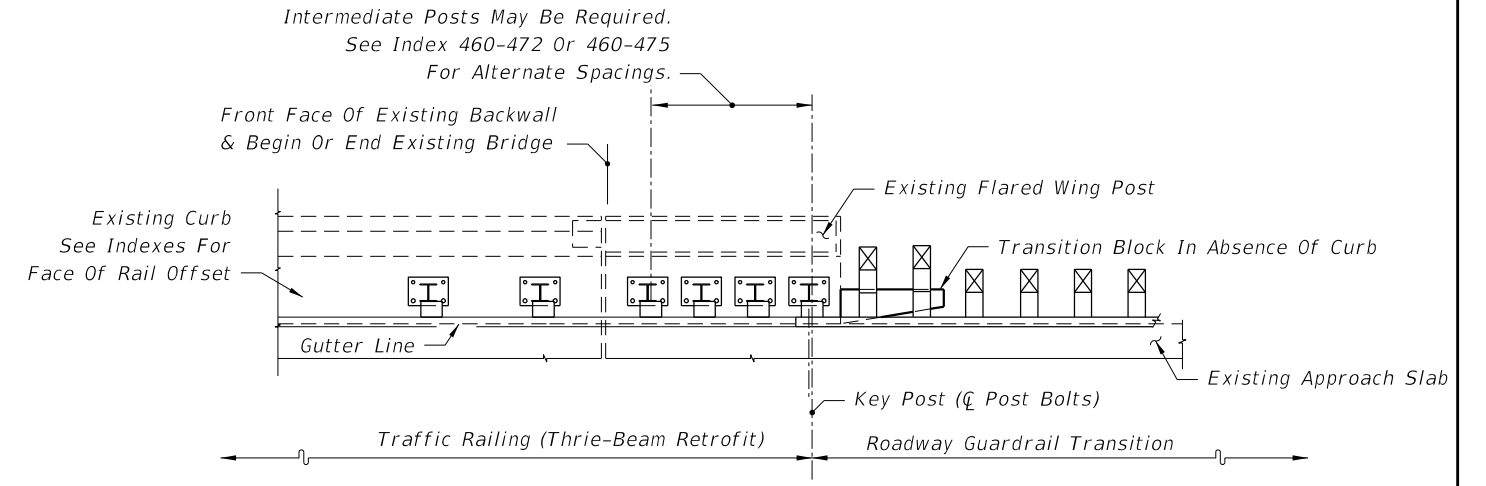

SEE INDEXES 460-472 & 460-475 - SCHEMES 5 & 6

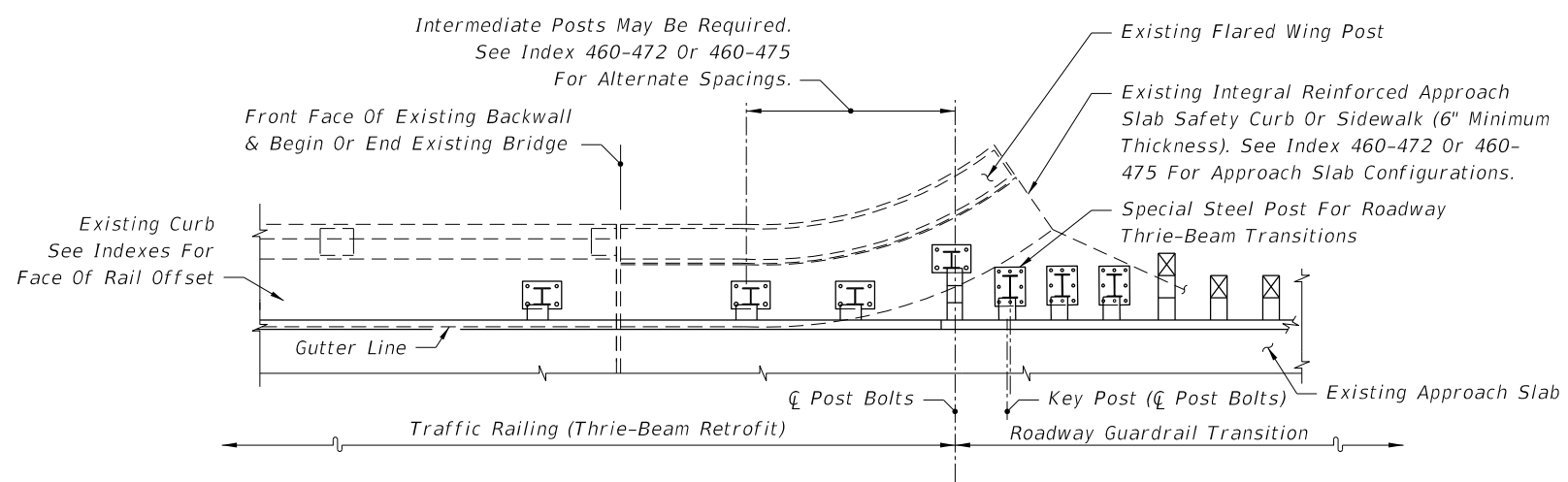

SEE INDEXES 460-472 & 460-475 - SCHEMES 3 & 4

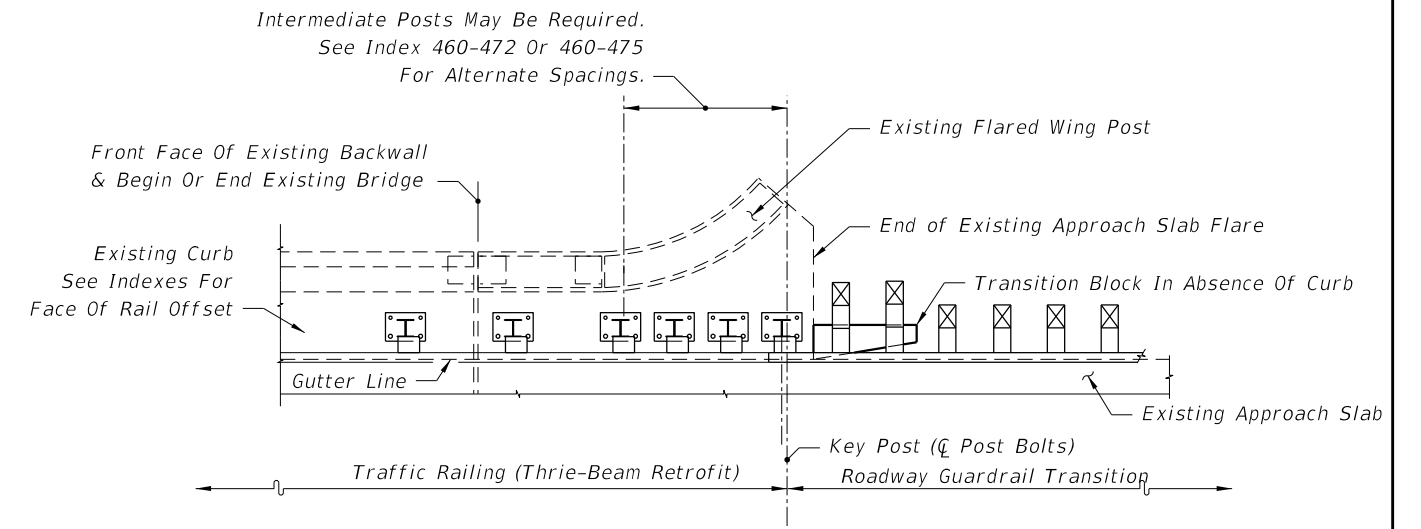

SEE INDEXES 460-472 & 460-475 - SCHEMES 5 & 6

PARTIAL PLAN VIEWS OF GUARDRAIL APPROACH TRANSITIONS AND CONNECTIONS FOR BRIDGE TRAFFIC RAILING (THRIE-BEAM RETROFIT)

10/20/2022 8:53:33 AM

LAST REVISION 11/01/19	REVISION DESCRIPTION:	 FY 2023-24 STANDARD PLANS	GUARDRAIL TRANSITIONS AND CONNECTIONS FOR EXISTING BRIDGES	INDEX 536-002	SHEET 7 of 28
---------------------------	-----------------------	---	--	------------------	------------------

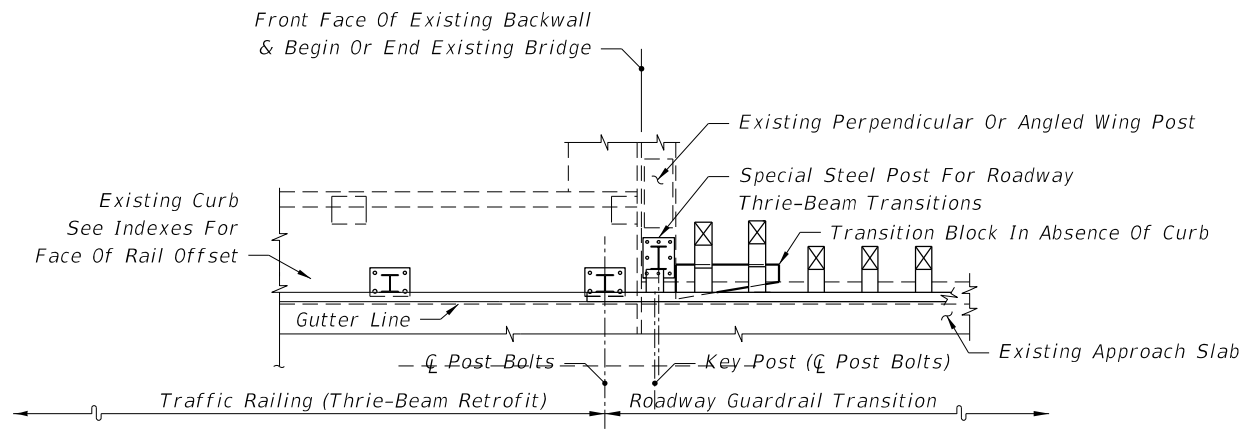

SEE INDEXES 460-473 & 460-476 - SCHEME 1

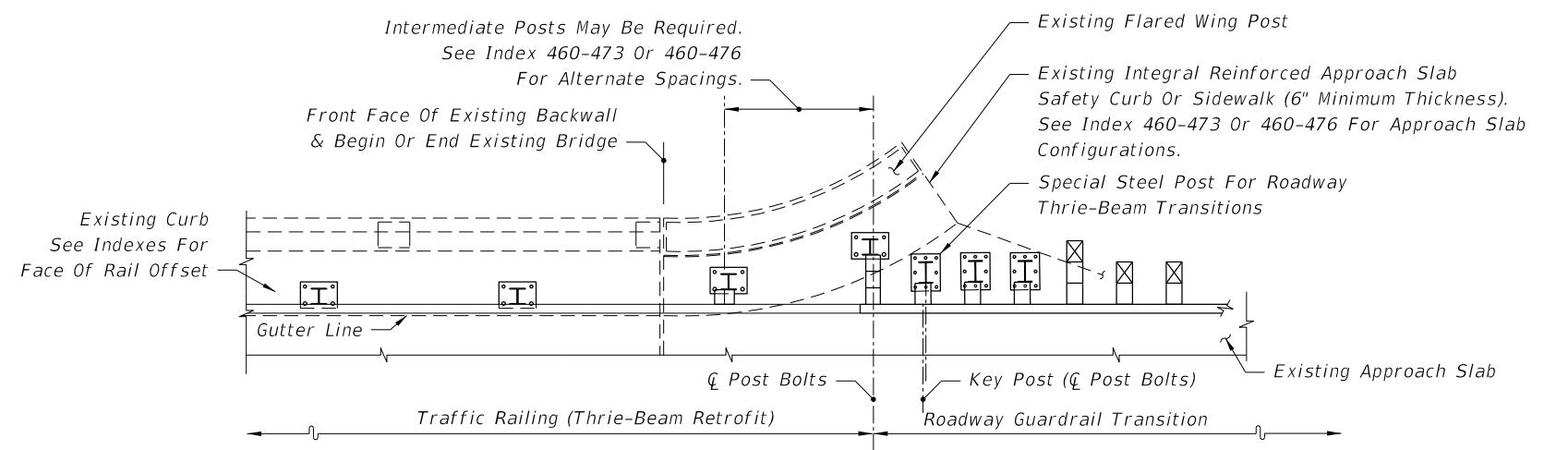

SEE INDEXES 460-473 & 460-476 - SCHEMES 3 & 4

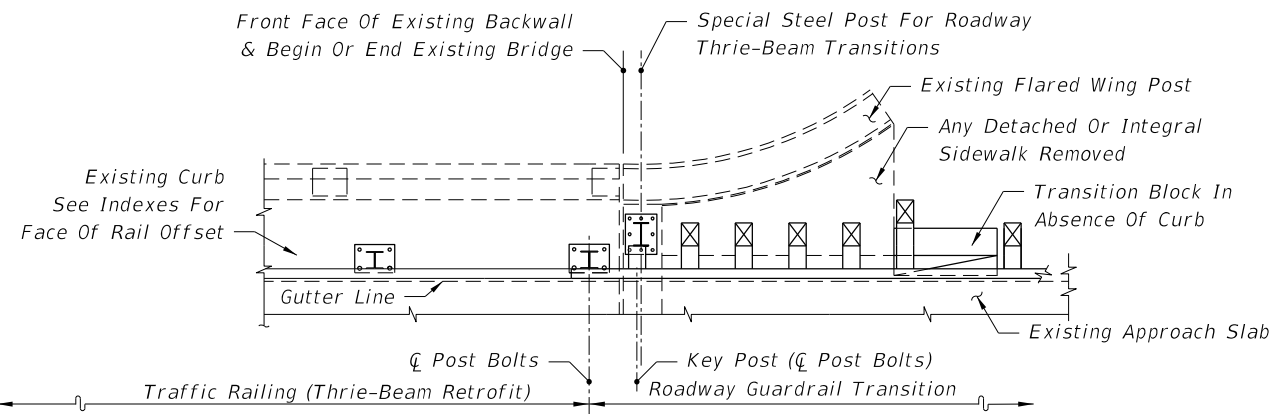

SEE INDEXES 460-473 & 460-476 - SCHEME 2

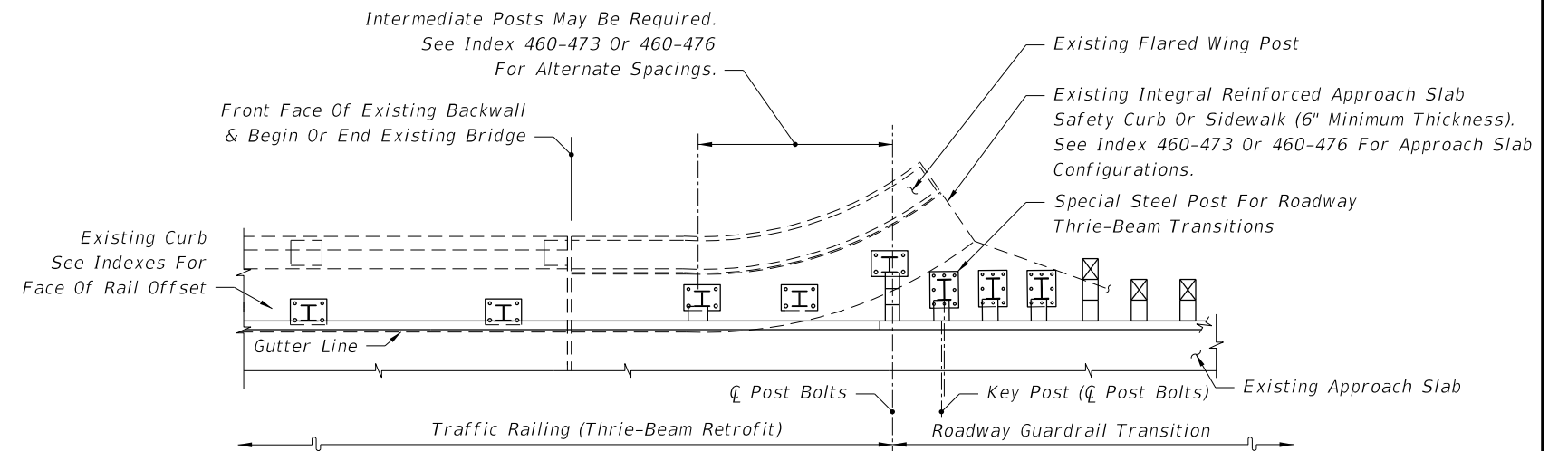

SEE INDEXES 460-473 & 460-476 - SCHEMES 3 & 4

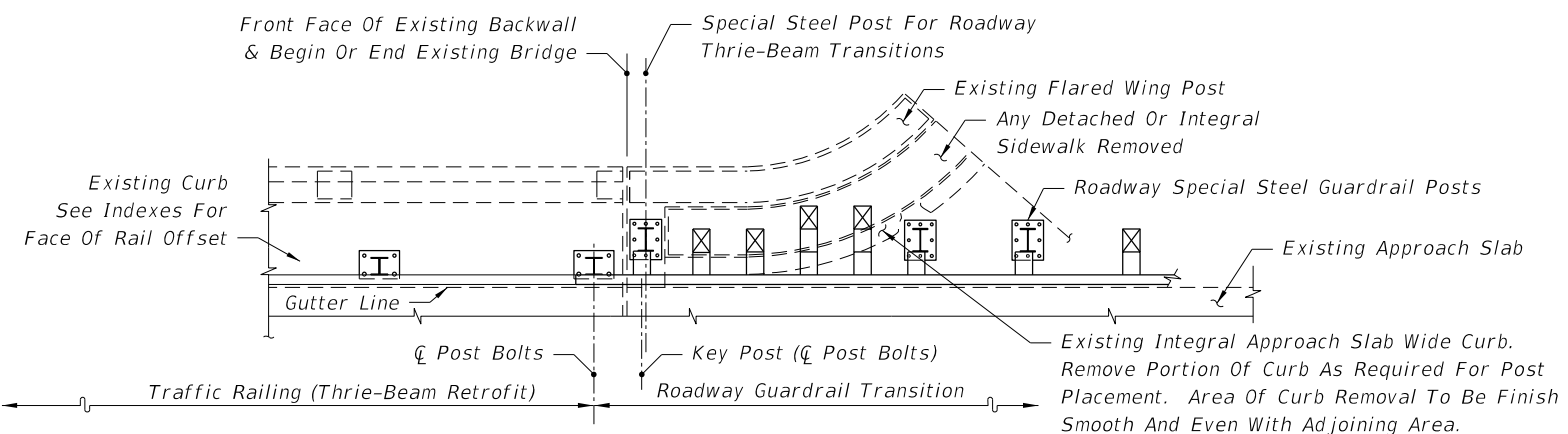

SEE INDEXES 460-473 & 460-476 - SCHEME 2

PARTIAL PLAN VIEWS OF GUARDRAIL APPROACH TRANSITIONS AND CONNECTIONS FOR BRIDGE TRAFFIC RAILING (THRIE-BEAM RETROFIT)

10/20/2022 8:53:34 AM

LAST REVISION 11/01/19	REVISION	DESCRIPTION:		FY 2023-24 STANDARD PLANS	GUARDRAIL TRANSITIONS AND CONNECTIONS FOR EXISTING BRIDGES	INDEX 536-002	SHEET 8 of 28
---------------------------	----------	--------------	--	------------------------------	---	------------------	------------------

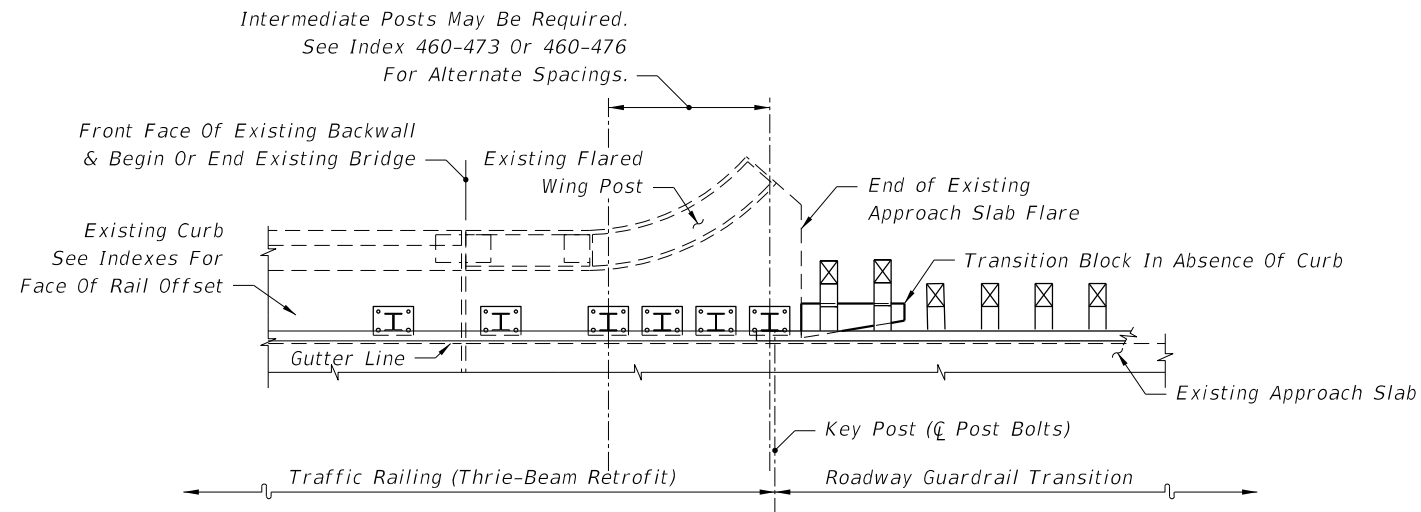

SEE INDEXES 460-473 & 460-476 - SCHEMES 5 & 6

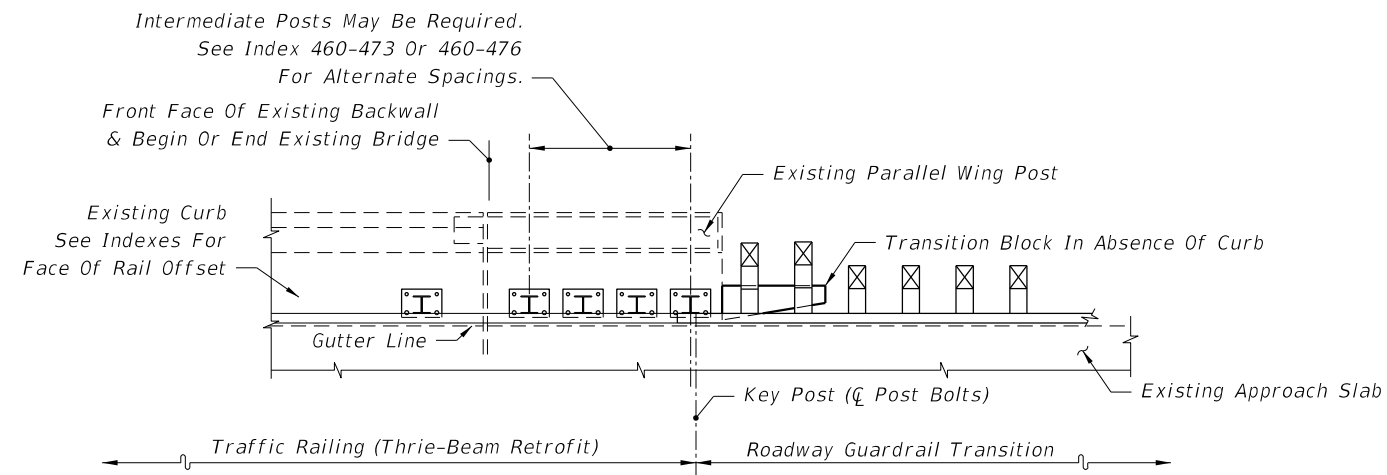

SEE INDEXES 460-473 & 460-476 - SCHEMES 5 & 6

PARTIAL PLAN VIEWS OF GUARDRAIL APPROACH TRANSITIONS AND CONNECTIONS
FOR BRIDGE TRAFFIC RAILING (THRIE-BEAM RETROFIT)

10/20/2022 8:53:35 AM

LAST REVISION 11/01/19	REVISION DESCRIPTION:	 FY 2023-24 STANDARD PLANS	GUARDRAIL TRANSITIONS AND CONNECTIONS FOR EXISTING BRIDGES	INDEX 536-002	SHEET 9 of 28
---------------------------	-----------------------	--	---	------------------	------------------

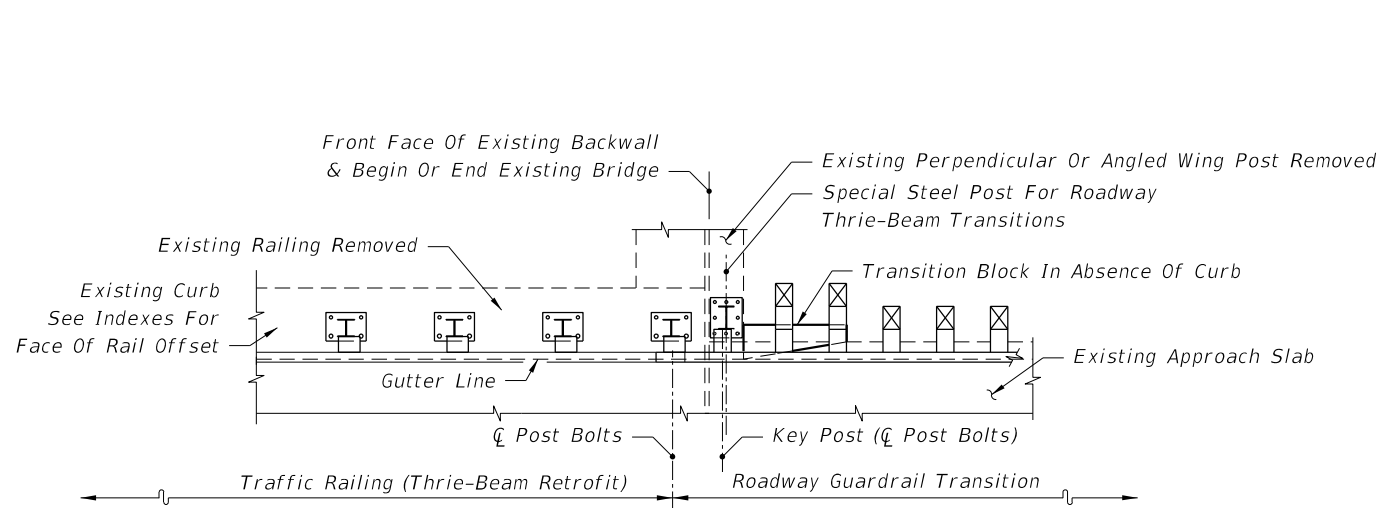

SEE INDEX 460-474 - SCHEME 1

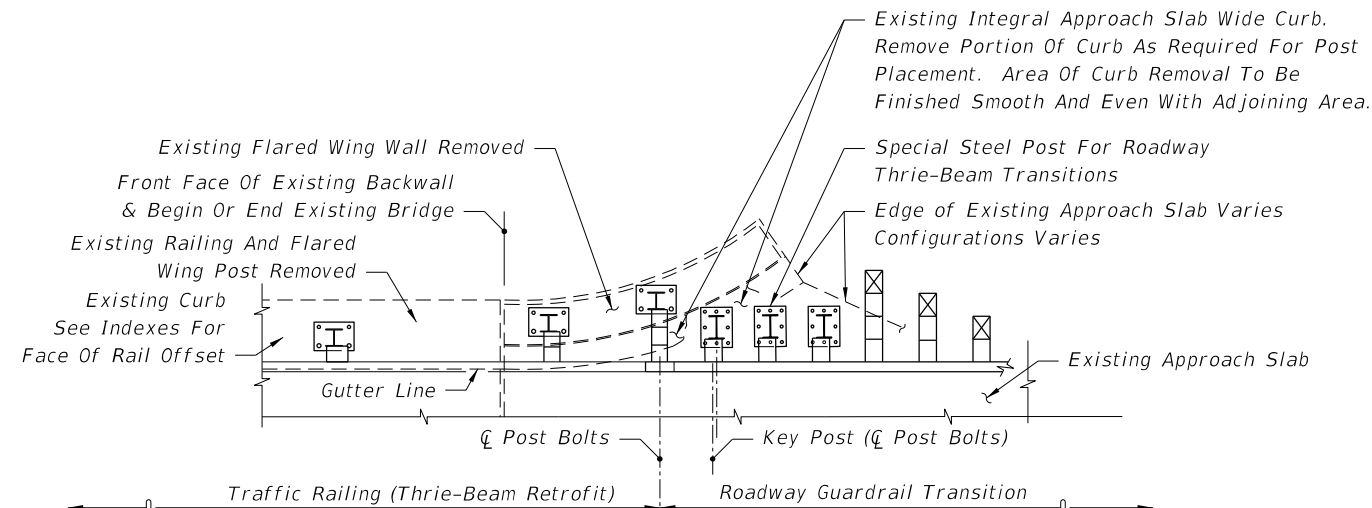

SEE INDEX 460-474 - SCHEME 3

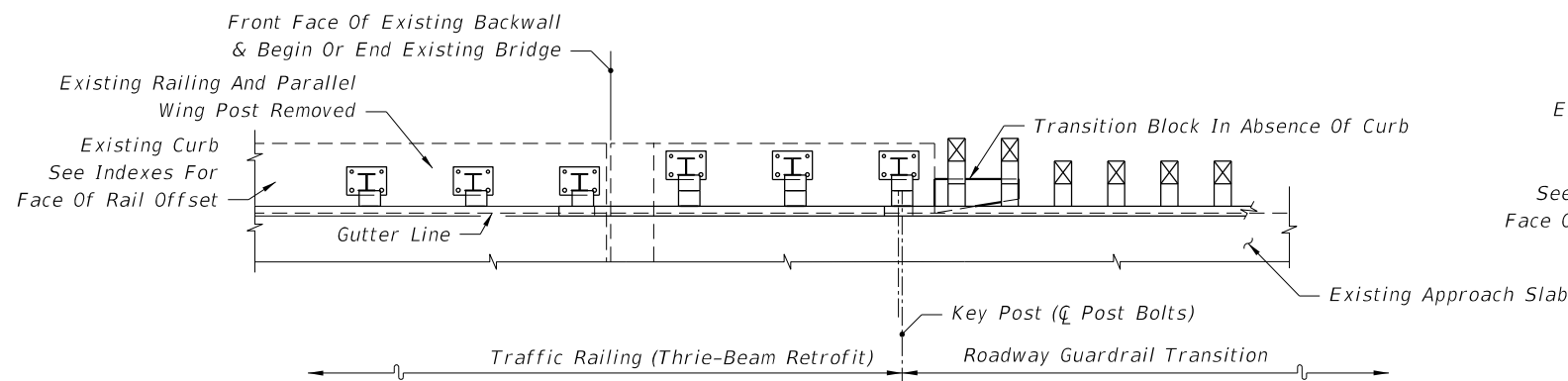

SEE INDEX 460-474 - SCHEME 2

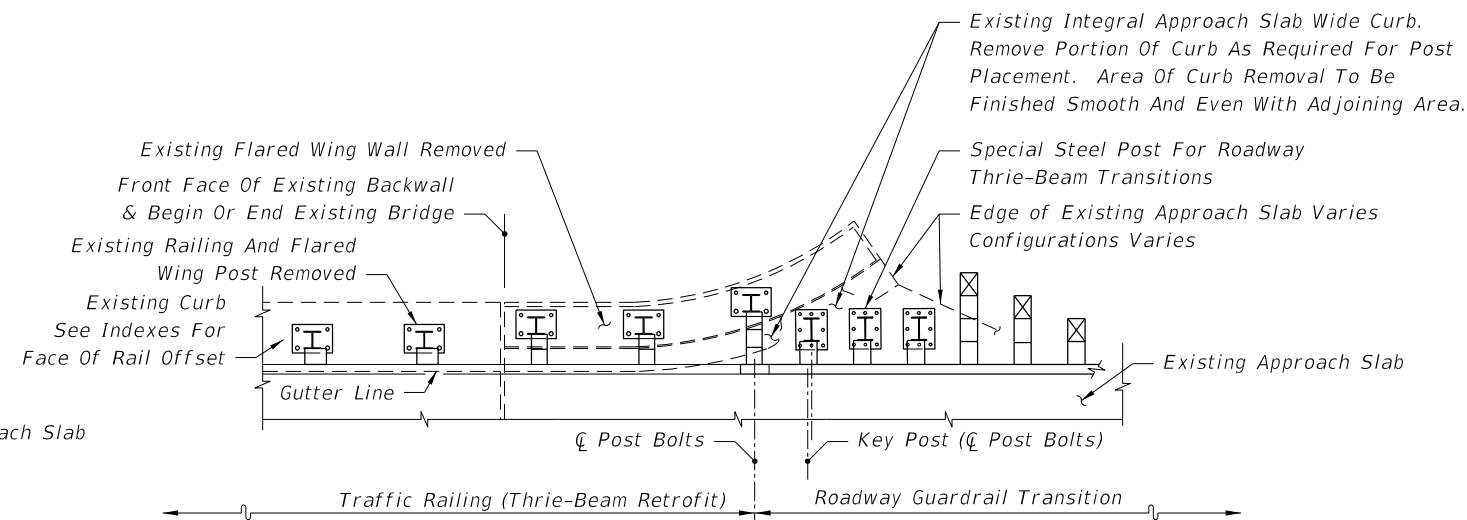

SEE INDEX 460-474 - SCHEME 3

PARTIAL PLAN VIEWS OF GUARDRAIL APPROACH TRANSITIONS AND CONNECTIONS FOR BRIDGE TRAFFIC RAILING (THRIE-BEAM RETROFIT)

10/20/2022 8:53:35 AM

LAST REVISION 11/01/19	REVISION DESCRIPTION:	 FY 2023-24 STANDARD PLANS	GUARDRAIL TRANSITIONS AND CONNECTIONS FOR EXISTING BRIDGES	INDEX 536-002	SHEET 10 of 28
---------------------------	-----------------------	--	--	------------------	-------------------

10/20/2022 8:53:36 AM

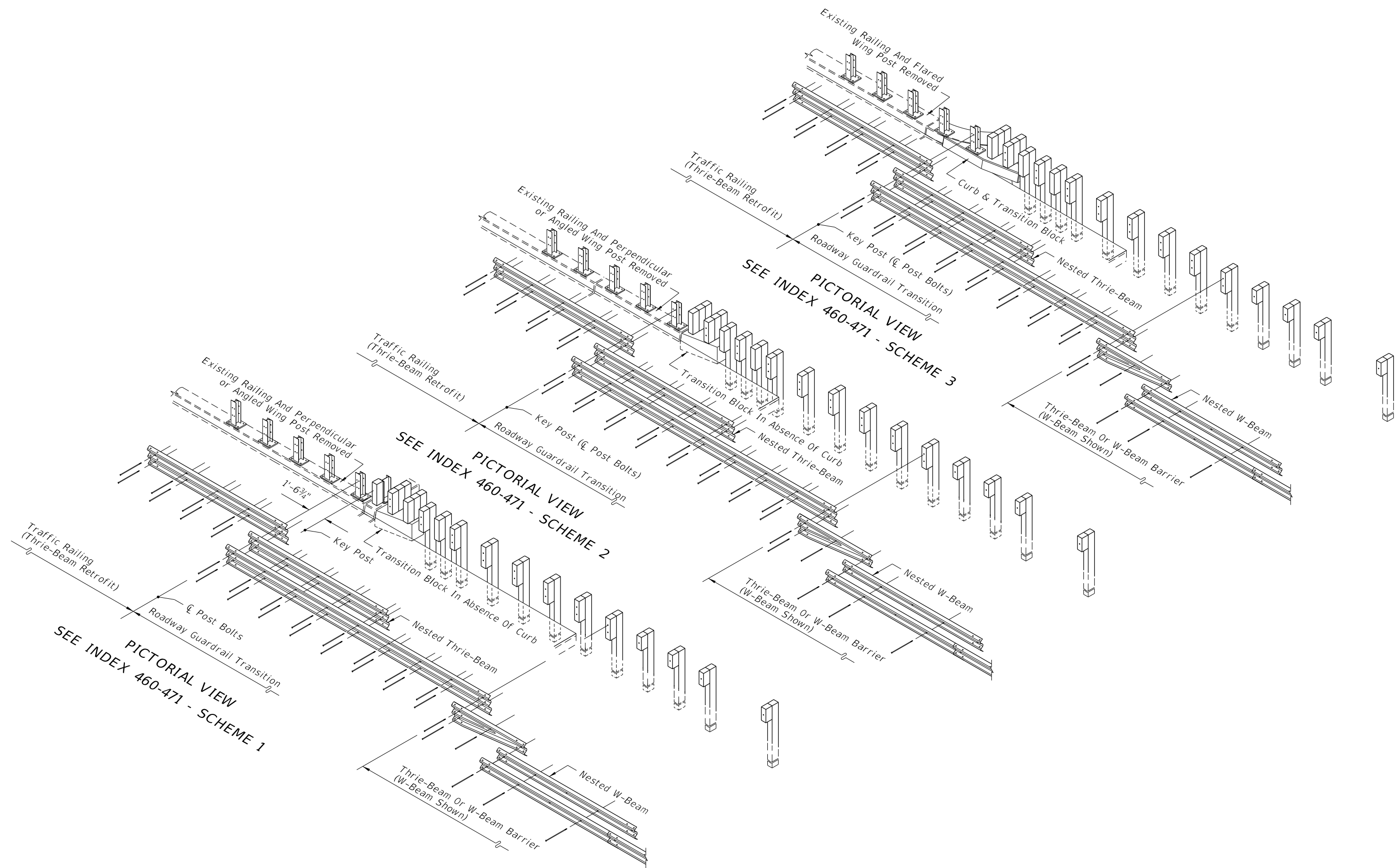

PICTORIAL VIEWS OF GUARDRAIL APPROACH TRANSITIONS AND CONNECTIONS FOR BRIDGE TRAFFIC RAILING (THRIE-BEAM RETROFIT)

LAST REVISION 11/01/19	DESCRIPTION:
---------------------------	--------------

FY 2023-24
STANDARD PLANS



GUARDRAIL TRANSITIONS AND CONNECTIONS FOR EXISTING BRIDGES

INDEX 536-002	SHEET 11 of 28
------------------	-------------------

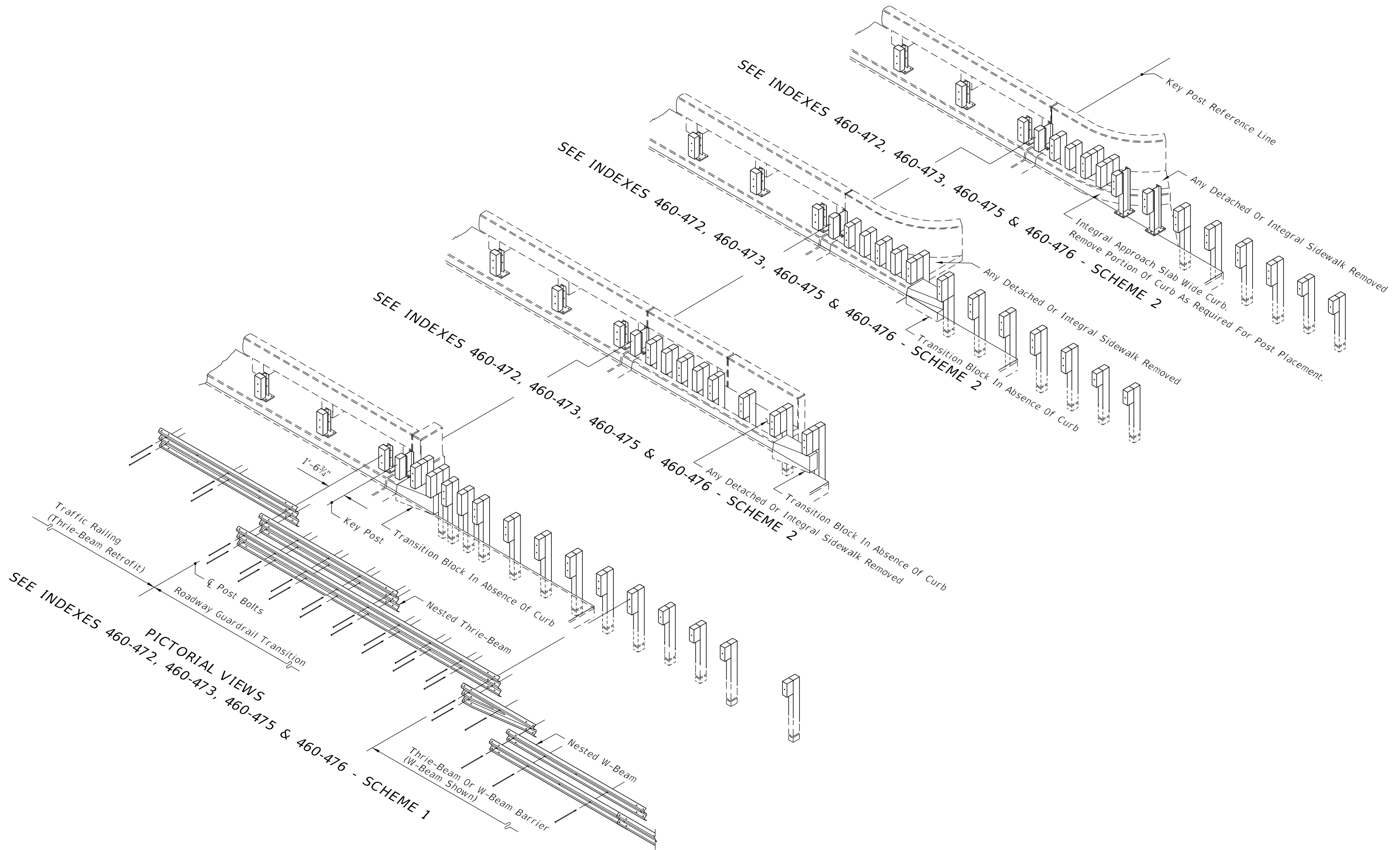

PICTORIAL VIEWS OF GUARDRAIL APPROACH TRANSITIONS AND CONNECTIONS FOR BRIDGE TRAFFIC RAILING (THRIE-BEAM RETROFIT)

10/20/2022 8:53:37 AM

LAST REVISION 11/01/19	DESCRIPTION: 	FY 2023-24 STANDARD PLANS	GUARDRAIL TRANSITIONS AND CONNECTIONS FOR EXISTING BRIDGES	INDEX 536-002	SHEET 12 of 28
---------------------------	---	------------------------------	--	------------------	-------------------

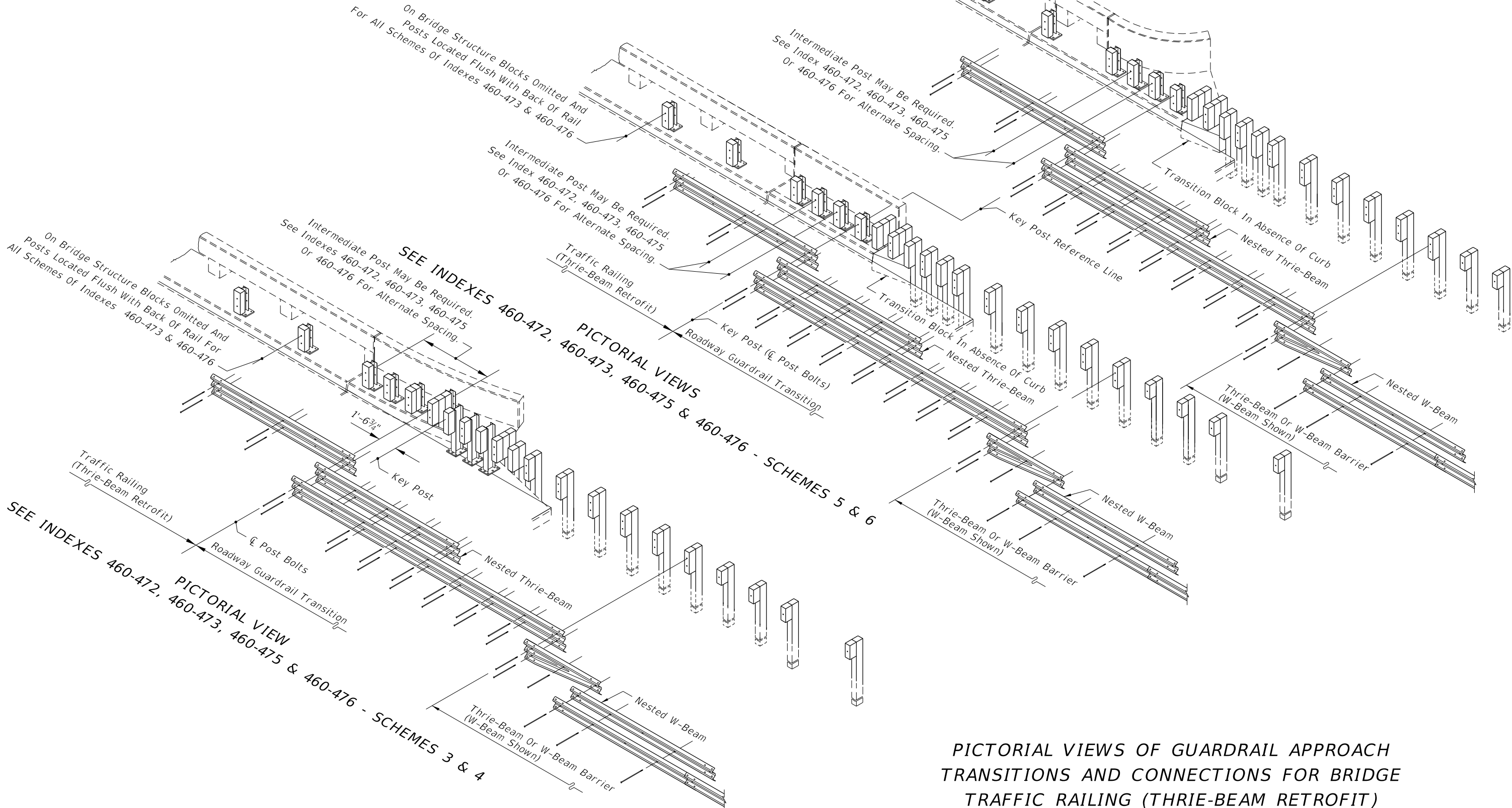

PICTORIAL VIEWS OF GUARDRAIL APPROACH TRANSITIONS AND CONNECTIONS FOR BRIDGE TRAFFIC RAILING (THRIE-BEAM RETROFIT)

10/20/2022 8:53:36 AM

LAST REVISION 11/01/19	DESCRIPTION:  FY 2023-24 STANDARD PLANS	GUARDRAIL TRANSITIONS AND CONNECTIONS FOR EXISTING BRIDGES	INDEX 536-002	SHEET 13 of 28
---------------------------	---	--	------------------	-------------------

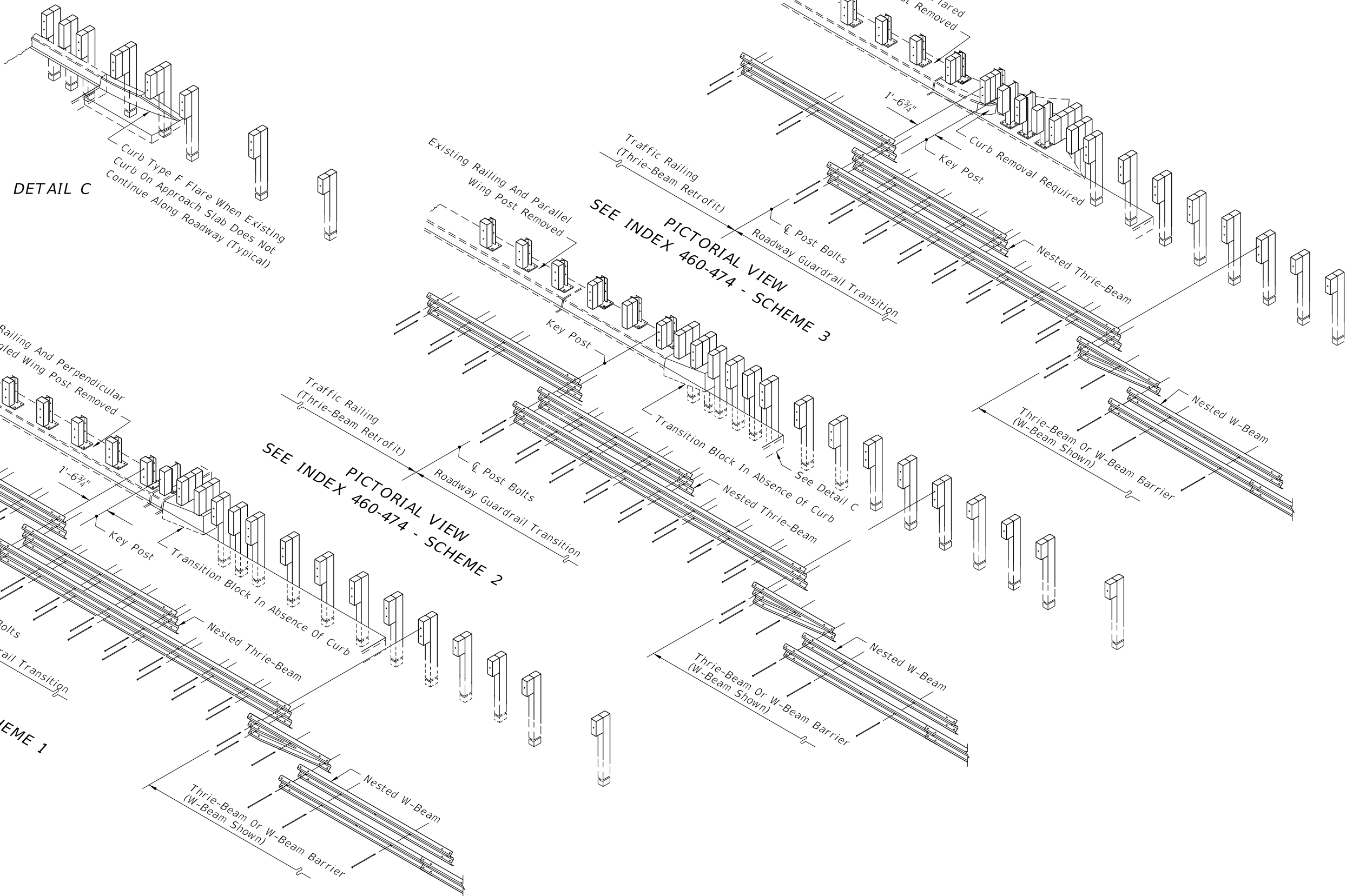

PICTORIAL VIEWS OF GUARDRAIL APPROACH TRANSITIONS AND CONNECTIONS FOR BRIDGE TRAFFIC RAILING (THRIE-BEAM RETROFIT)

10/20/2022 8:53:39 AM

LAST REVISION 11/01/19	DESCRIPTION:	 FY 2023-24 STANDARD PLANS	GUARDRAIL TRANSITIONS AND CONNECTIONS FOR EXISTING BRIDGES	INDEX 536-002	SHEET 14 of 28
---------------------------	--------------	--	--	------------------	-------------------

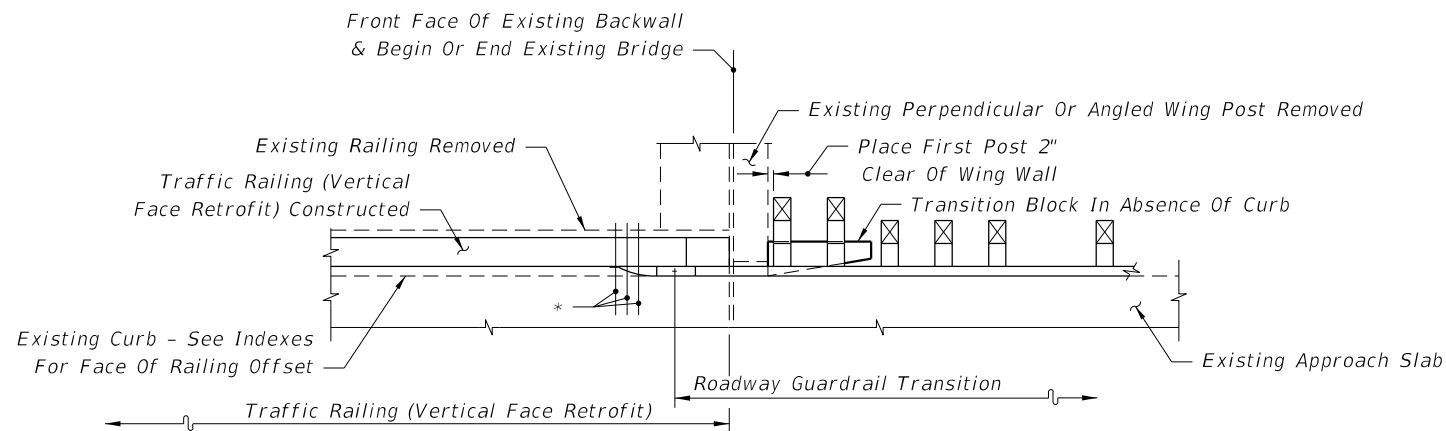

SEE INDEX 521-481 - SCHEME 1

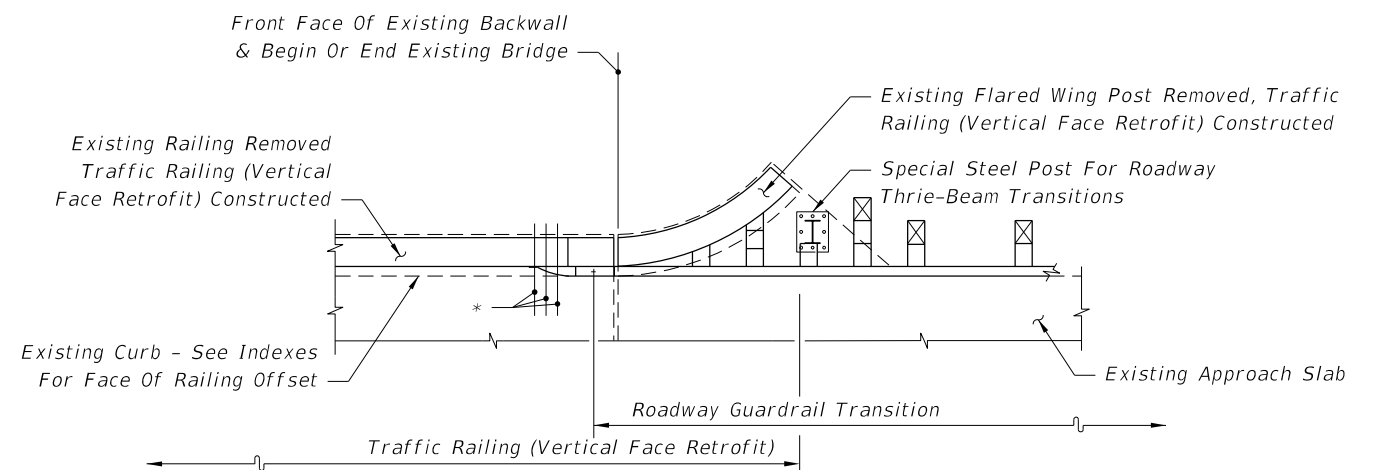

SEE INDEX 521-481 - SCHEME 3

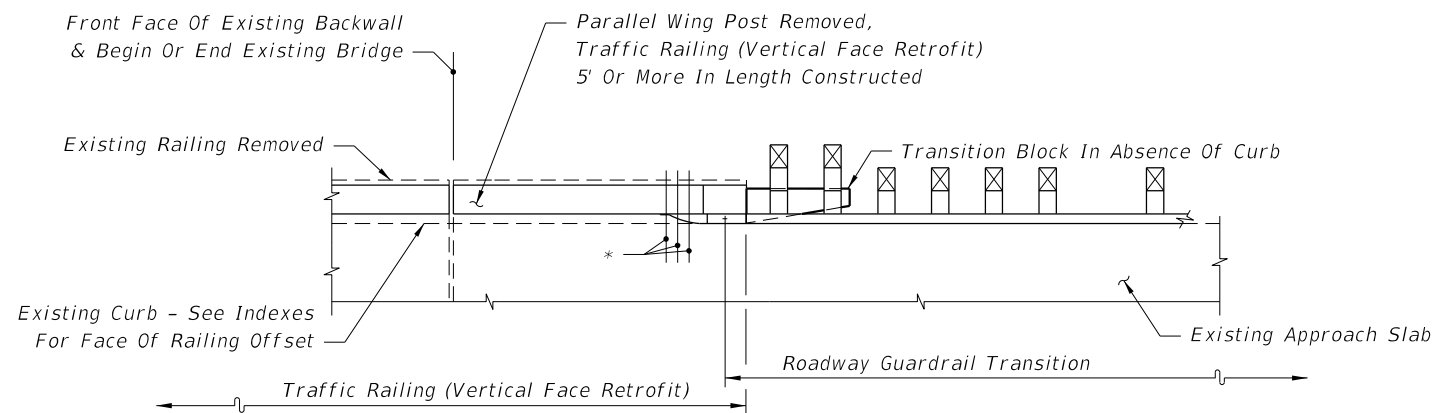

SEE INDEX 521-481 - SCHEME 2

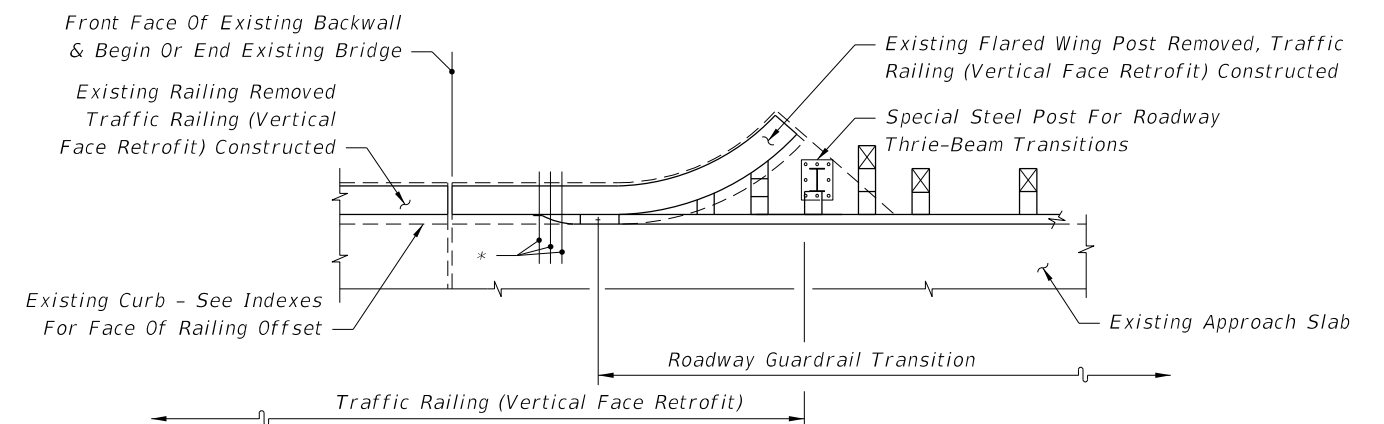

SEE INDEX 521-481 - SCHEME 3

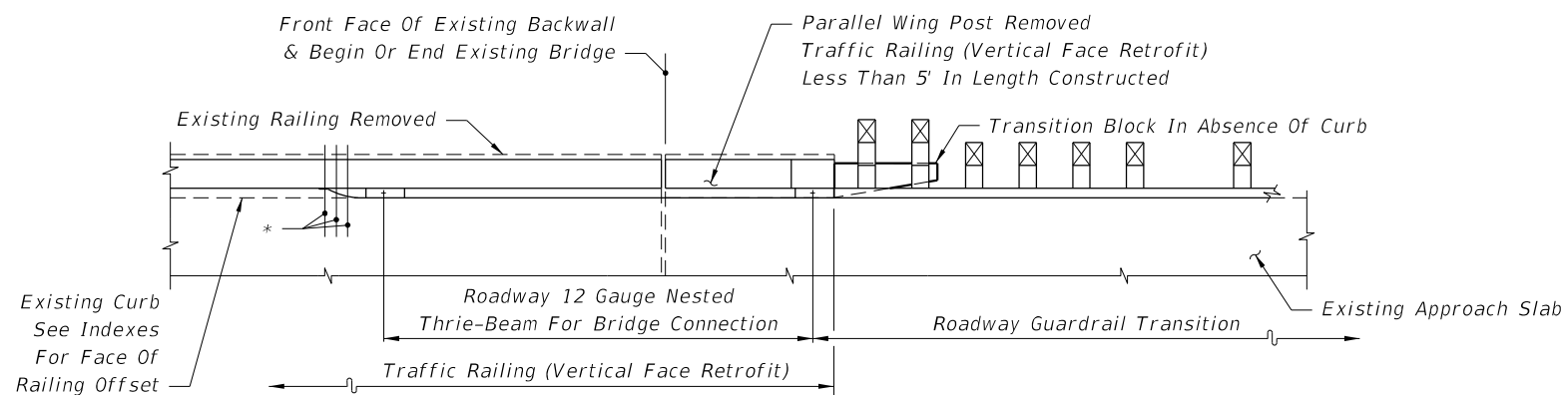

SEE INDEX 521-481 - SCHEME 2

Note:
 * 21" x 12" x 5/8" Thrie-Beam Terminal Connector Plate (Back-Up Plate), And 7/8"Ø x 12" Long HS
 Hex Bolts And Nuts (5 Req'd.) With 2 1/4" OD Plain Round Washers Under Heads And Nuts

PARTIAL PLAN VIEWS OF TRAFFIC RAILING (VERTICAL FACE RETROFIT)

10/20/2022 8:53:40 AM

LAST REVISION 11/01/19	REVISION	DESCRIPTION:		FY 2023-24 STANDARD PLANS	GUARDRAIL TRANSITIONS AND CONNECTIONS FOR EXISTING BRIDGES	INDEX 536-002	SHEET 15 of 28
---------------------------	----------	--------------	---	------------------------------	---	------------------	-------------------

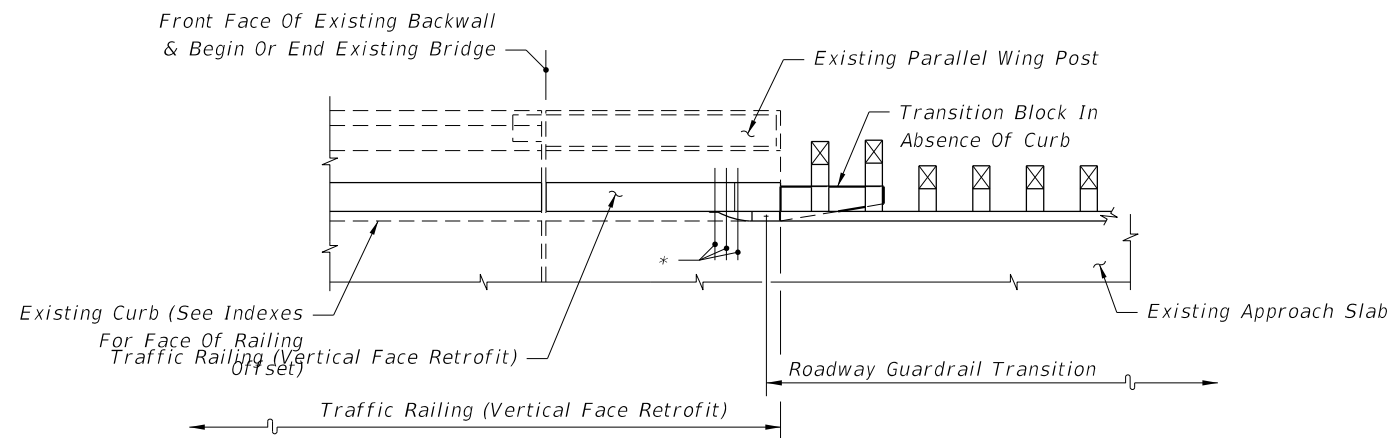

SEE INDEX 521-405 OR 521-482 - SCHEME 2

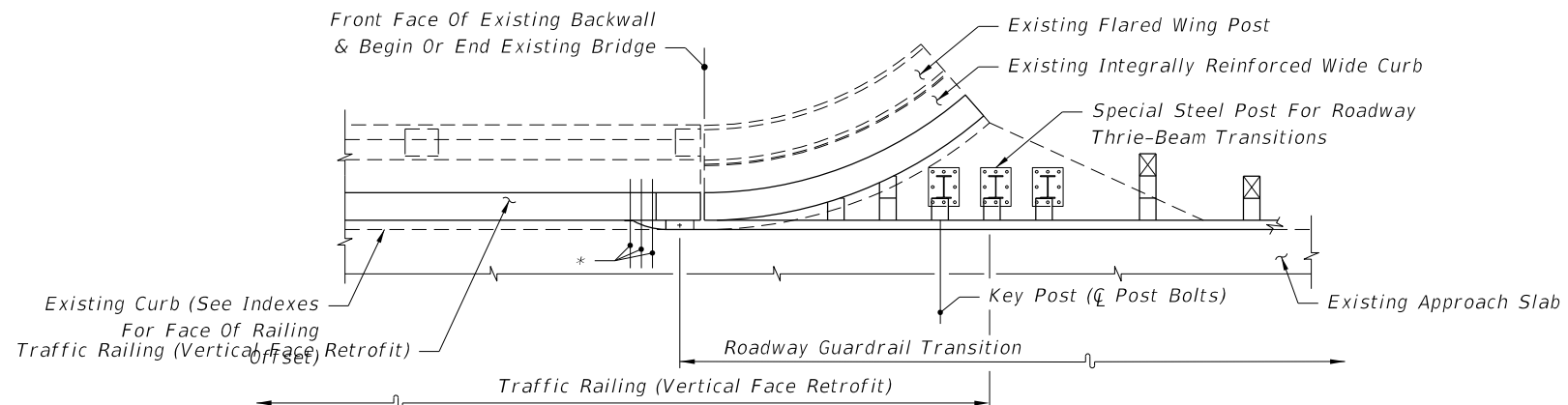

SEE INDEX 521-405 OR 521-482 - SCHEME 3

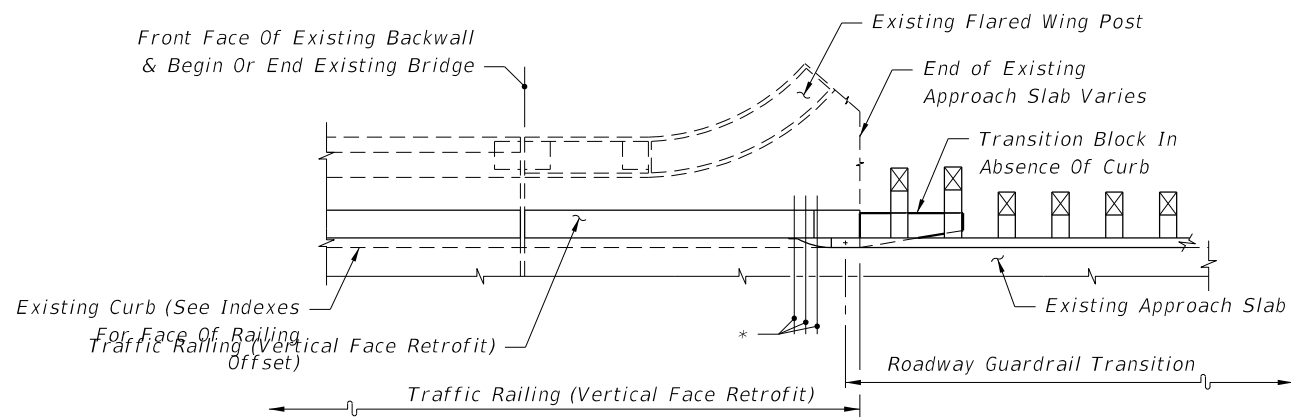

SEE INDEX 521-405 OR 521-482 - SCHEME 2

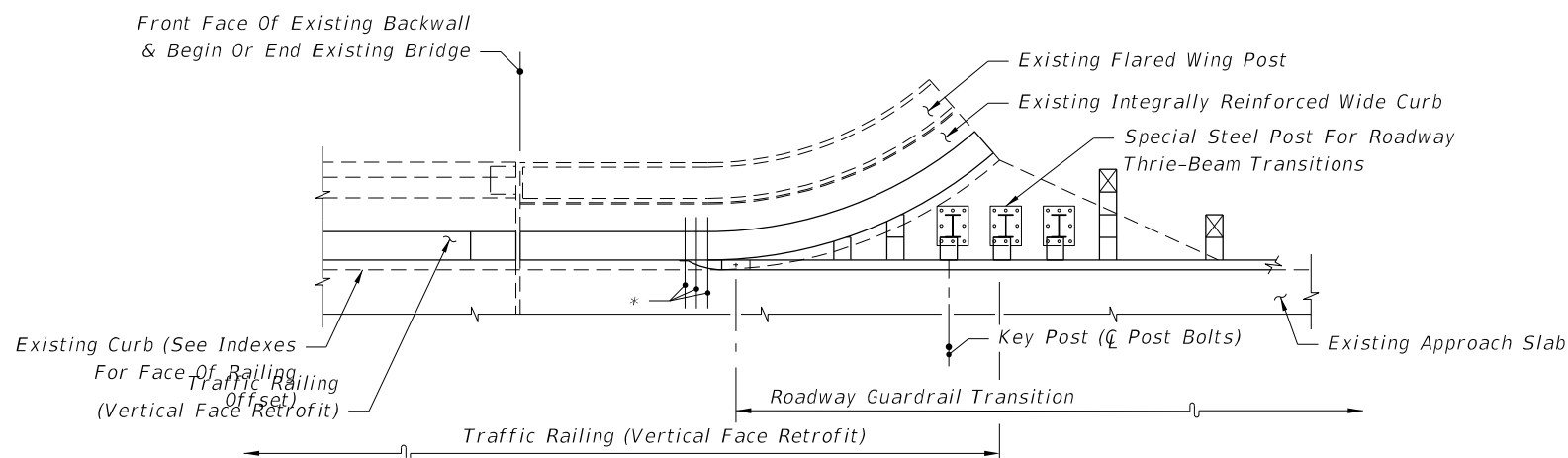

SEE INDEX 521-405 OR 521-482 - SCHEME 3

Note:
 * 21" x 12" x 5/8" Thrie-Beam Terminal Connector Plate (Back-Up Plate), And 7/8"Ø x 12" Long
 HS Hex Bolts And Nuts (5 Reqd.) With 2 1/4" OD Plain Round Washers Under Heads And Nuts

PARTIAL PLAN VIEWS OF TRAFFIC RAILING (VERTICAL FACE RETROFIT)
 (INDEX 521-482 SHOWN, INDEX 521-405 SIMILAR)

10/20/2022 8:53:41 AM

LAST REVISION 11/01/19	REVISION DESCRIPTION:	 FY 2023-24 STANDARD PLANS	GUARDRAIL TRANSITIONS AND CONNECTIONS FOR EXISTING BRIDGES	INDEX 536-002	SHEET 16 of 28
---------------------------	--------------------------	--	---	------------------	-------------------

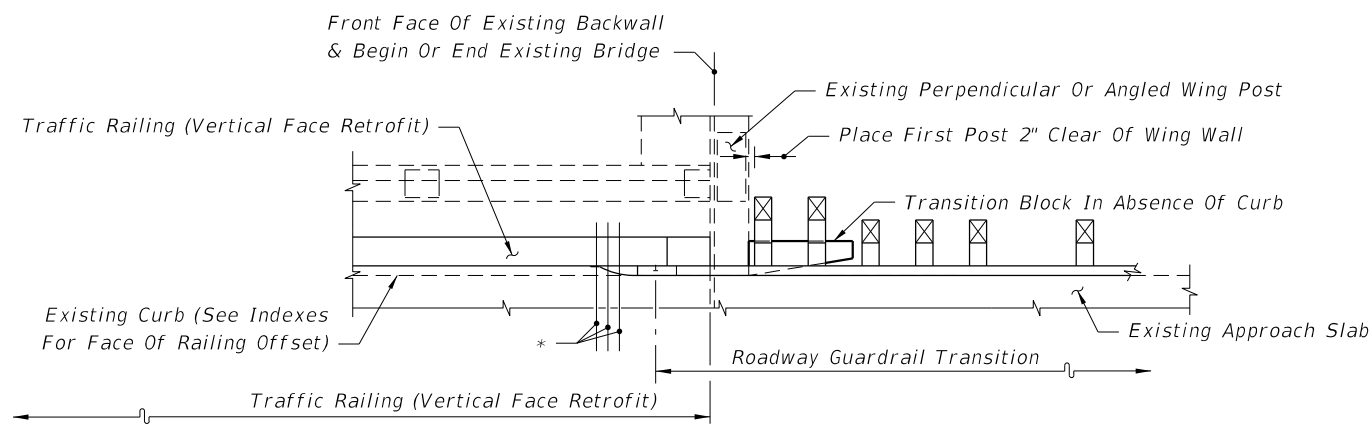

SEE INDEX 521-405 OR 521-482 - SCHEME 1

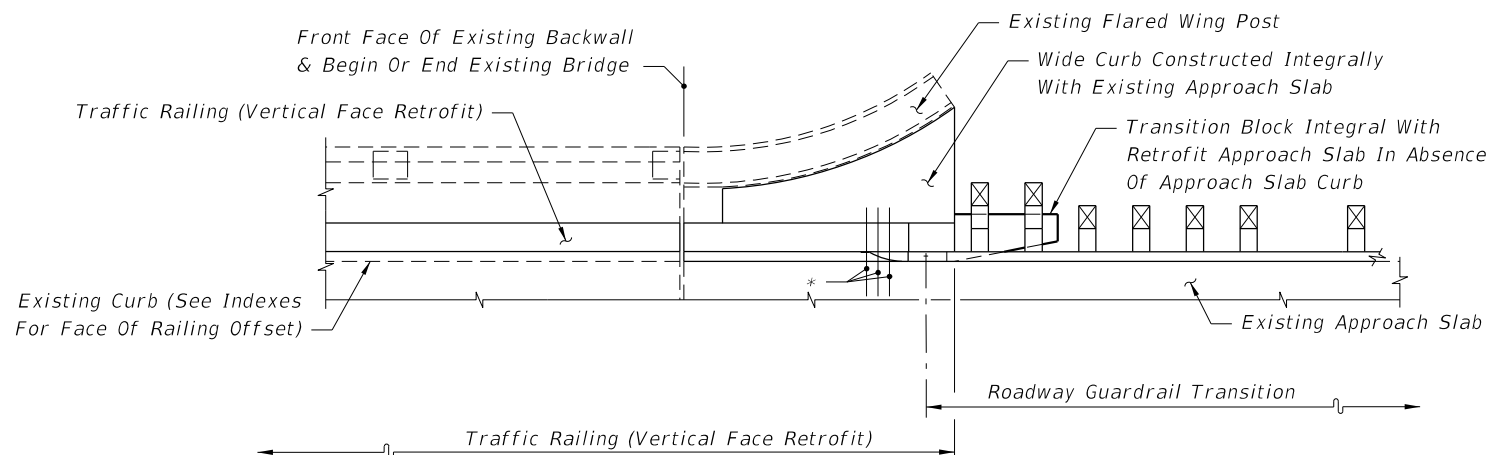

SEE INDEX 521-405 OR 521-482 - SCHEME 5

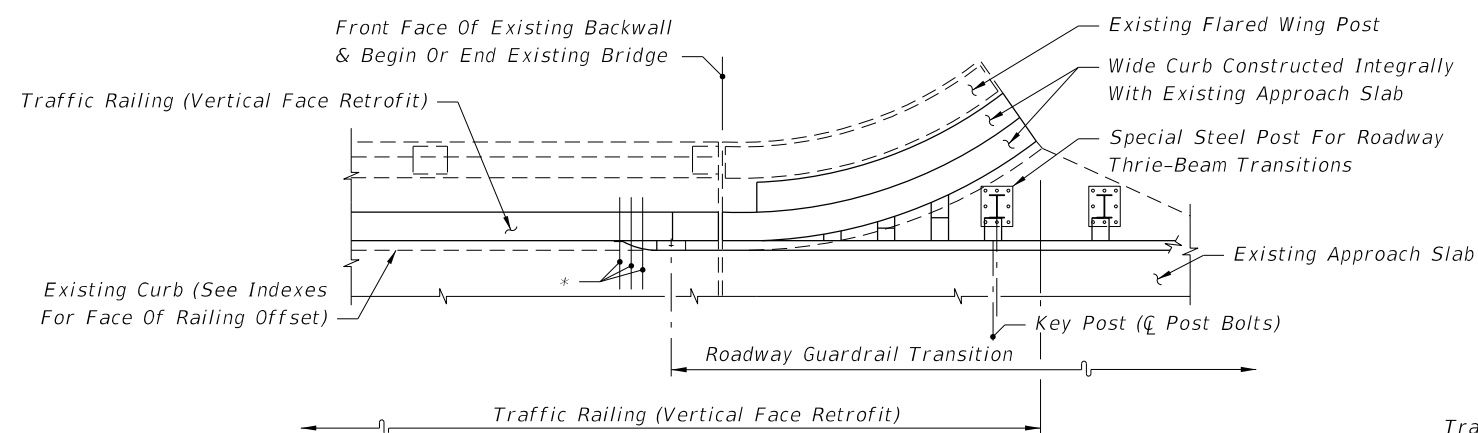

SEE INDEX 521-405 OR 521-482 - SCHEME 4

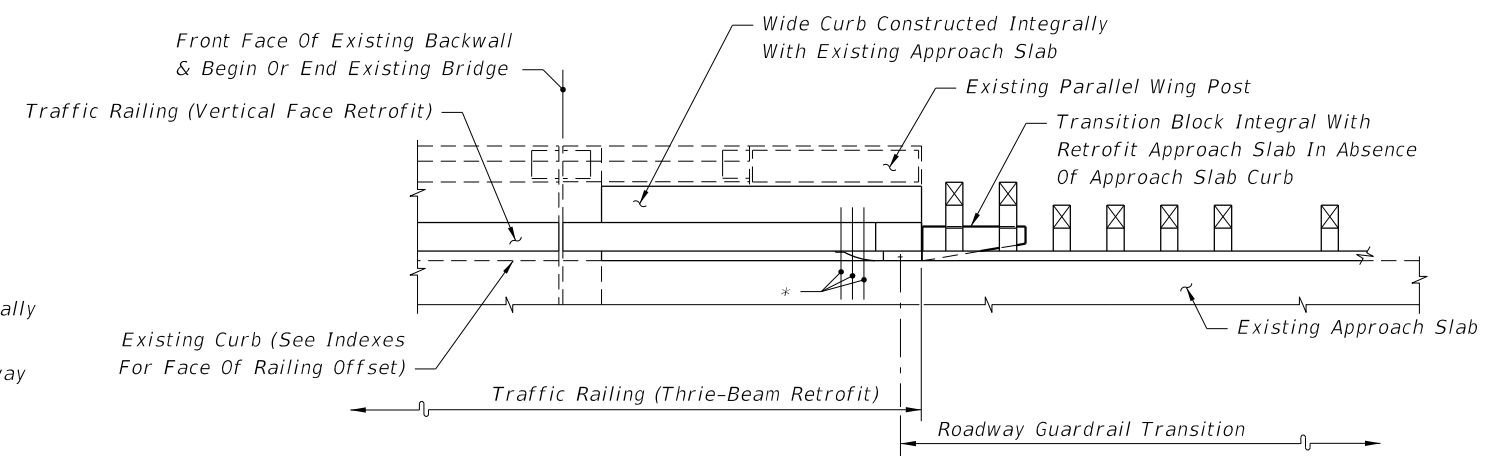

SEE INDEX 521-405 OR 521-482 - SCHEME 5

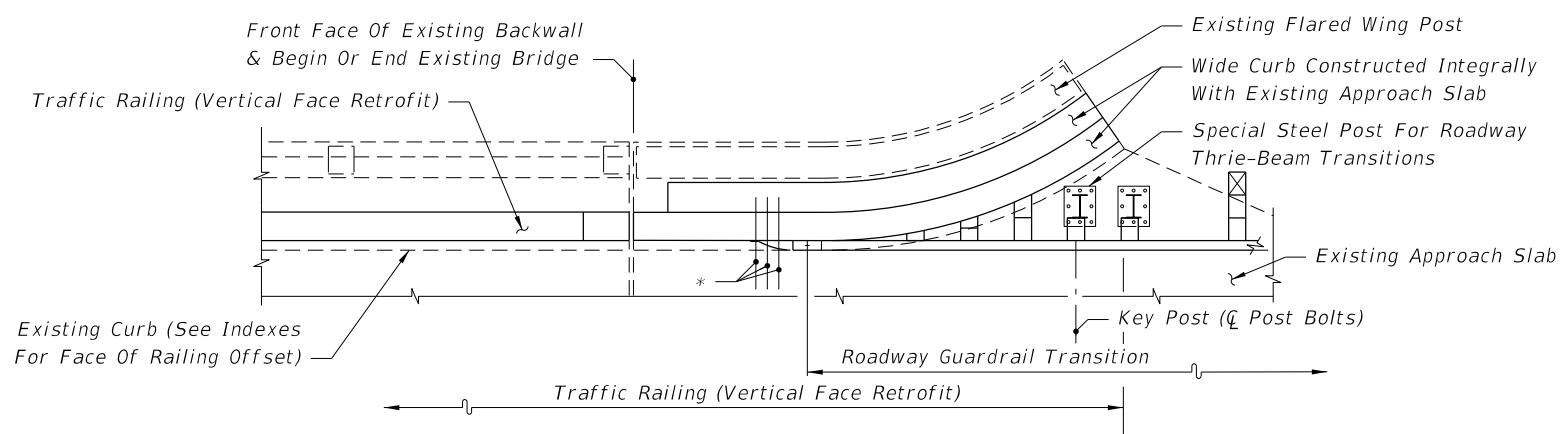

SEE INDEX 521-405 OR 521-482 - SCHEME 4

Note:
 *21" x 12" x 5/8" Thrie-Beam Terminal Connector Plate (Back-Up Plate), And 7/8"Ø x 12" Long HS Hex Bolts And Nuts (5 Req'd.) With 2 1/4" OD Plain Round Washers Under Heads And Nuts

PARTIAL PLAN VIEWS OF TRAFFIC RAILING (VERTICAL FACE RETROFIT)
 (INDEX 521-482 SHOWN, INDEX 521-405 SIMILAR)

10/20/2022 8:53:42 AM

LAST REVISION 11/01/19	REVISION	DESCRIPTION:		FY 2023-24 STANDARD PLANS	GUARDRAIL TRANSITIONS AND CONNECTIONS FOR EXISTING BRIDGES	INDEX 536-002	SHEET 17 of 28
---------------------------	----------	--------------	--	------------------------------	---	------------------	-------------------

10/20/2022 8:53:43 AM

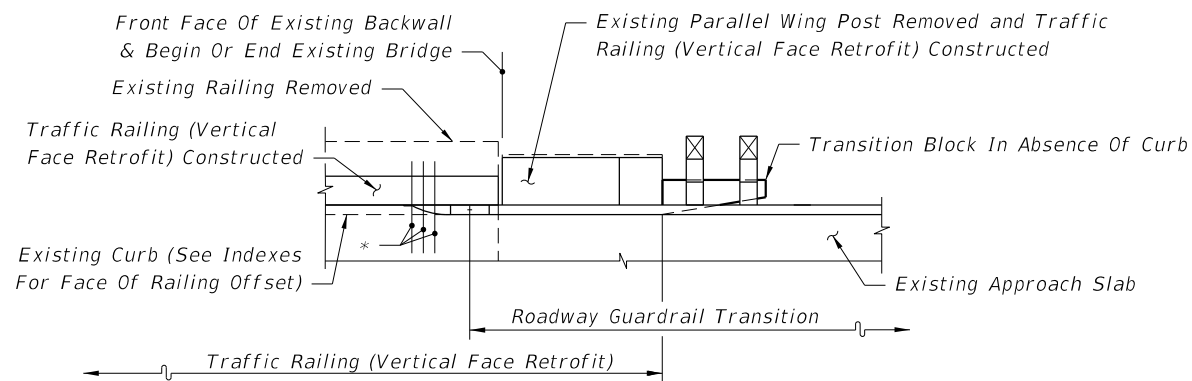

SEE INDEX 521-483 - SCHEME 2

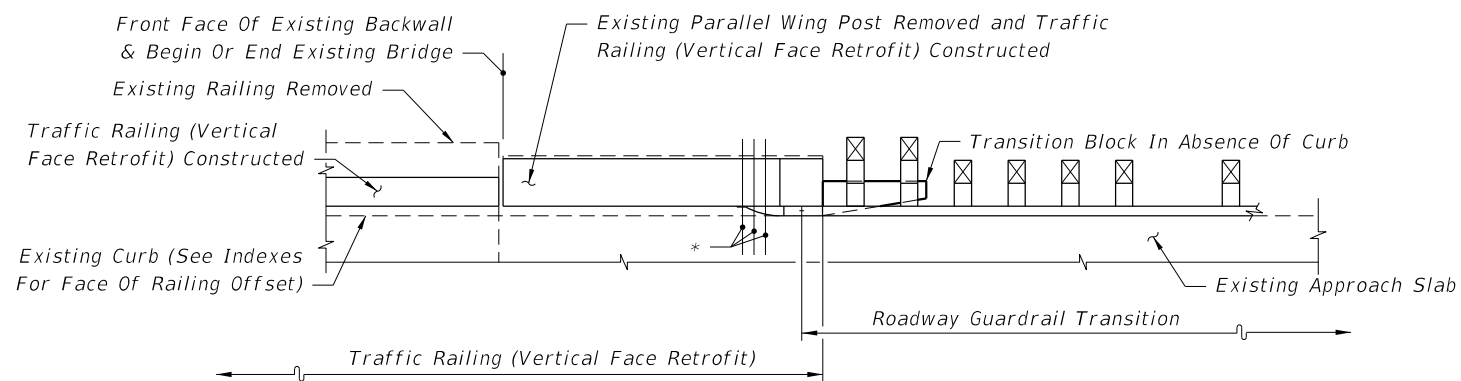

SEE INDEX 521-483 - SCHEME 2

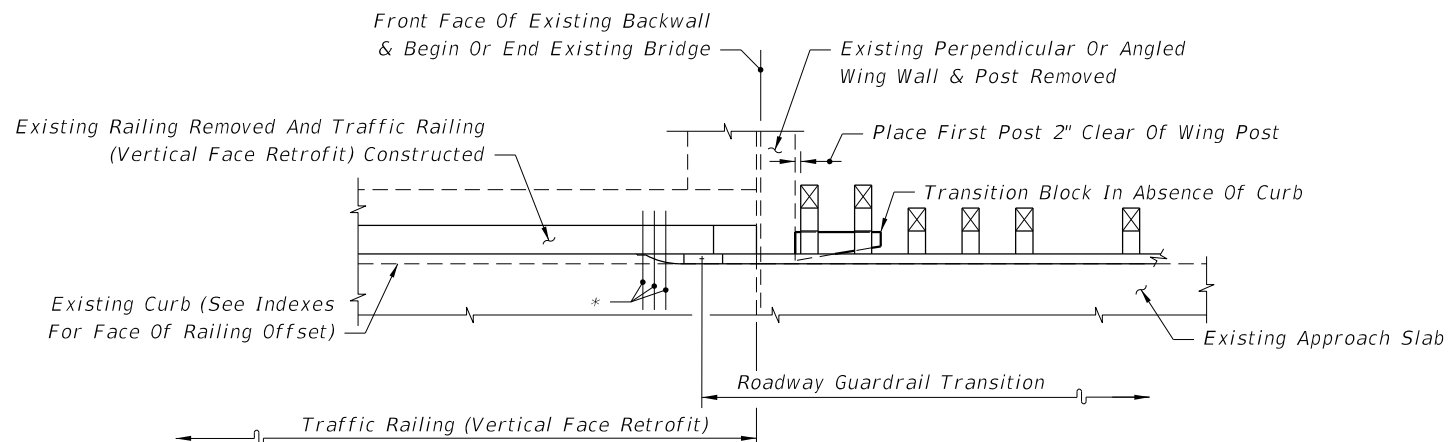

SEE INDEX 521-483 - SCHEME 1

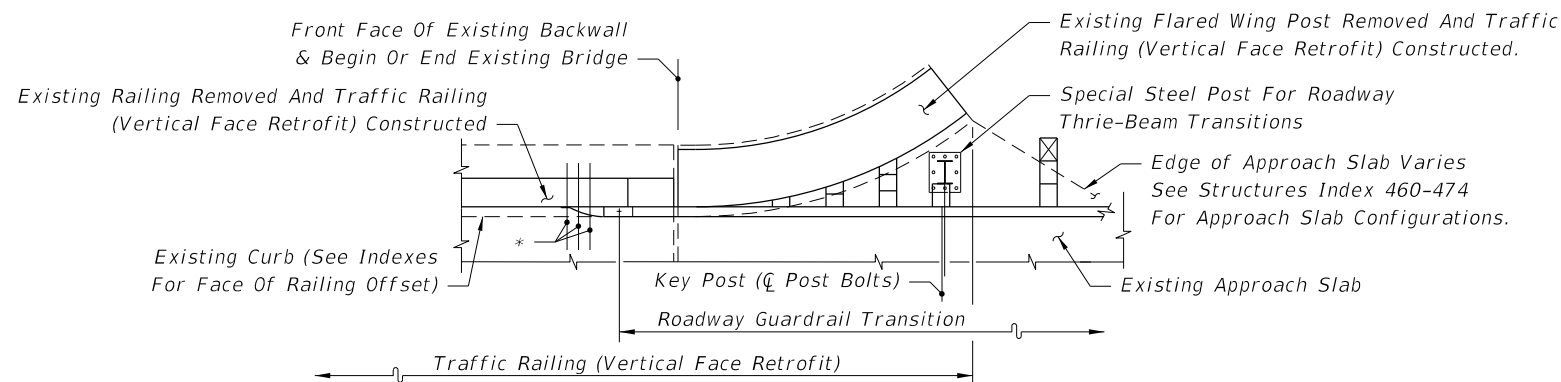

SEE INDEX 521-483 - SCHEME 3

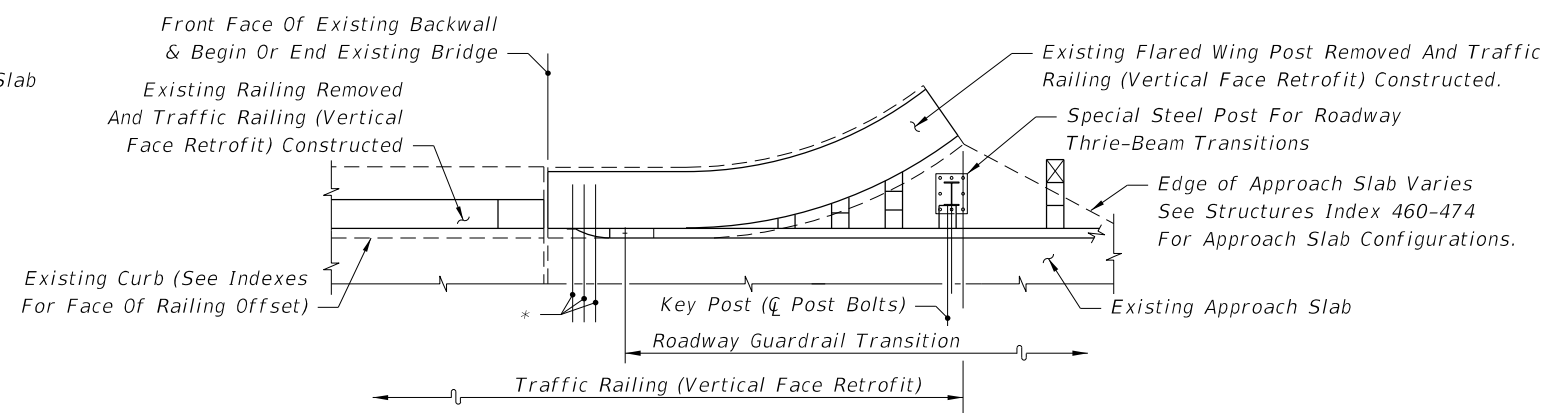

SEE INDEX 521-483 - SCHEME 3

Note:

* 21" x 12" x 5/8" Thrie-Beam Terminal Connector Plate (Back-Up Plate), And 7/8"Ø HS Hex Bolts And Nuts (12" Long For Scheme 1 And Length To Fit For Schemes 2 And 3) (5 Req'd.) With 2 1/4" OD Plain Round Washers Under Heads And Nuts

PARTIAL PLAN VIEWS OF TRAFFIC RAILING (VERTICAL FACE RETROFIT)

LAST REVISION 11/01/19	REVISION	DESCRIPTION:		FY 2023-24 STANDARD PLANS	GUARDRAIL TRANSITIONS AND CONNECTIONS FOR EXISTING BRIDGES	INDEX 536-002	SHEET 18 of 28
---------------------------	----------	--------------	---	------------------------------	---	------------------	-------------------

10/20/2022 8:53:44 AM

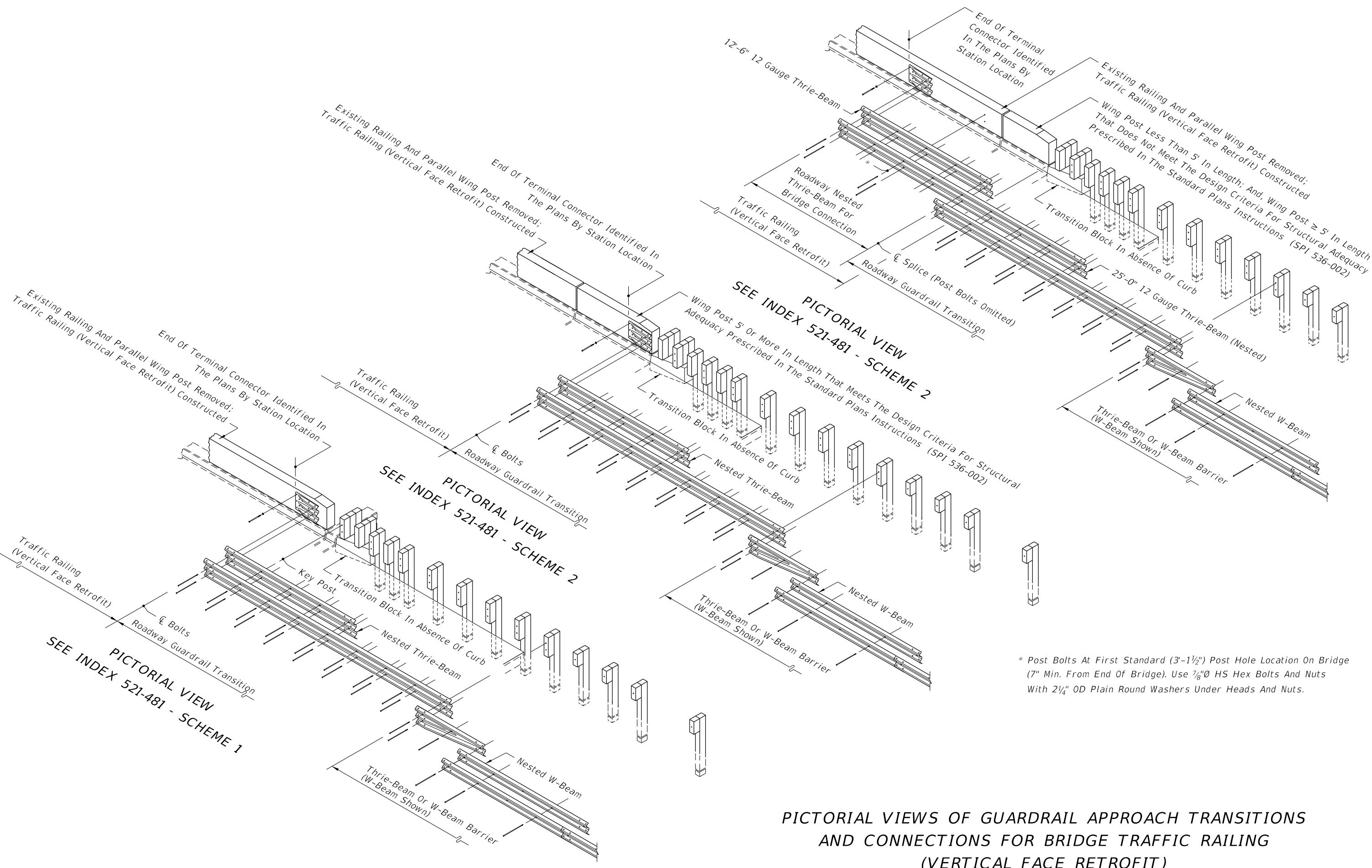

* Post Bolts At First Standard (3'-1 1/2") Post Hole Location On Bridge (7" Min. From End Of Bridge). Use 7/8" HS Hex Bolts And Nuts With 2 1/4" OD Plain Round Washers Under Heads And Nuts.

PICTORIAL VIEWS OF GUARDRAIL APPROACH TRANSITIONS AND CONNECTIONS FOR BRIDGE TRAFFIC RAILING (VERTICAL FACE RETROFIT)

LAST REVISION 11/01/19	REVISION DESCRIPTION:	 FY 2023-24 STANDARD PLANS	GUARDRAIL TRANSITIONS AND CONNECTIONS FOR EXISTING BRIDGES	INDEX 536-002	SHEET 19 of 28
---------------------------	-----------------------	---	--	------------------	-------------------

10/20/2022 8:53:45 AM

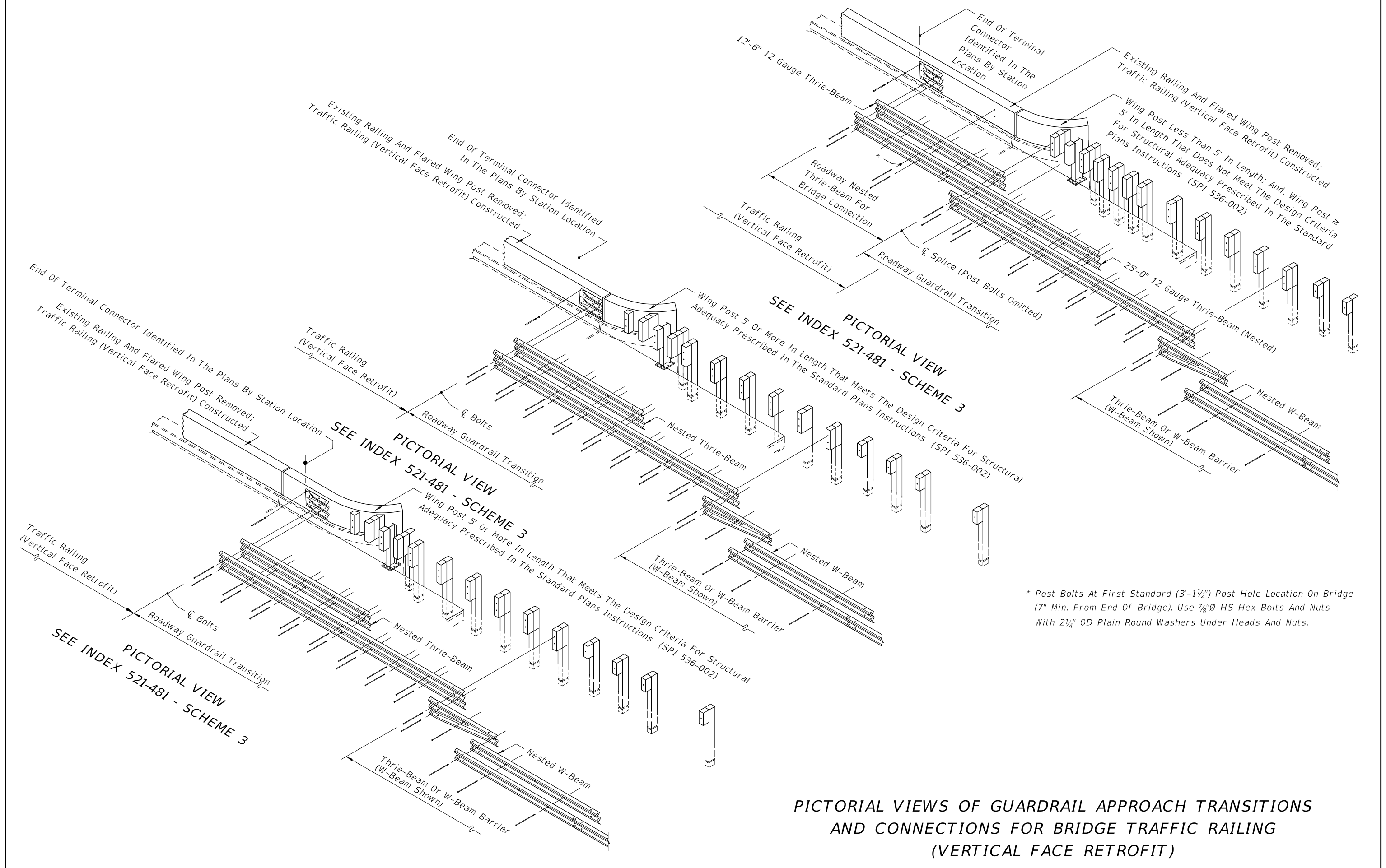

PICTORIAL VIEWS OF GUARDRAIL APPROACH TRANSITIONS AND CONNECTIONS FOR BRIDGE TRAFFIC RAILING (VERTICAL FACE RETROFIT)

LAST REVISION 11/01/19	DESCRIPTION:  FY 2023-24 STANDARD PLANS	GUARDRAIL TRANSITIONS AND CONNECTIONS FOR EXISTING BRIDGES	INDEX 536-002	SHEET 20 of 28
---------------------------	---	--	------------------	-------------------

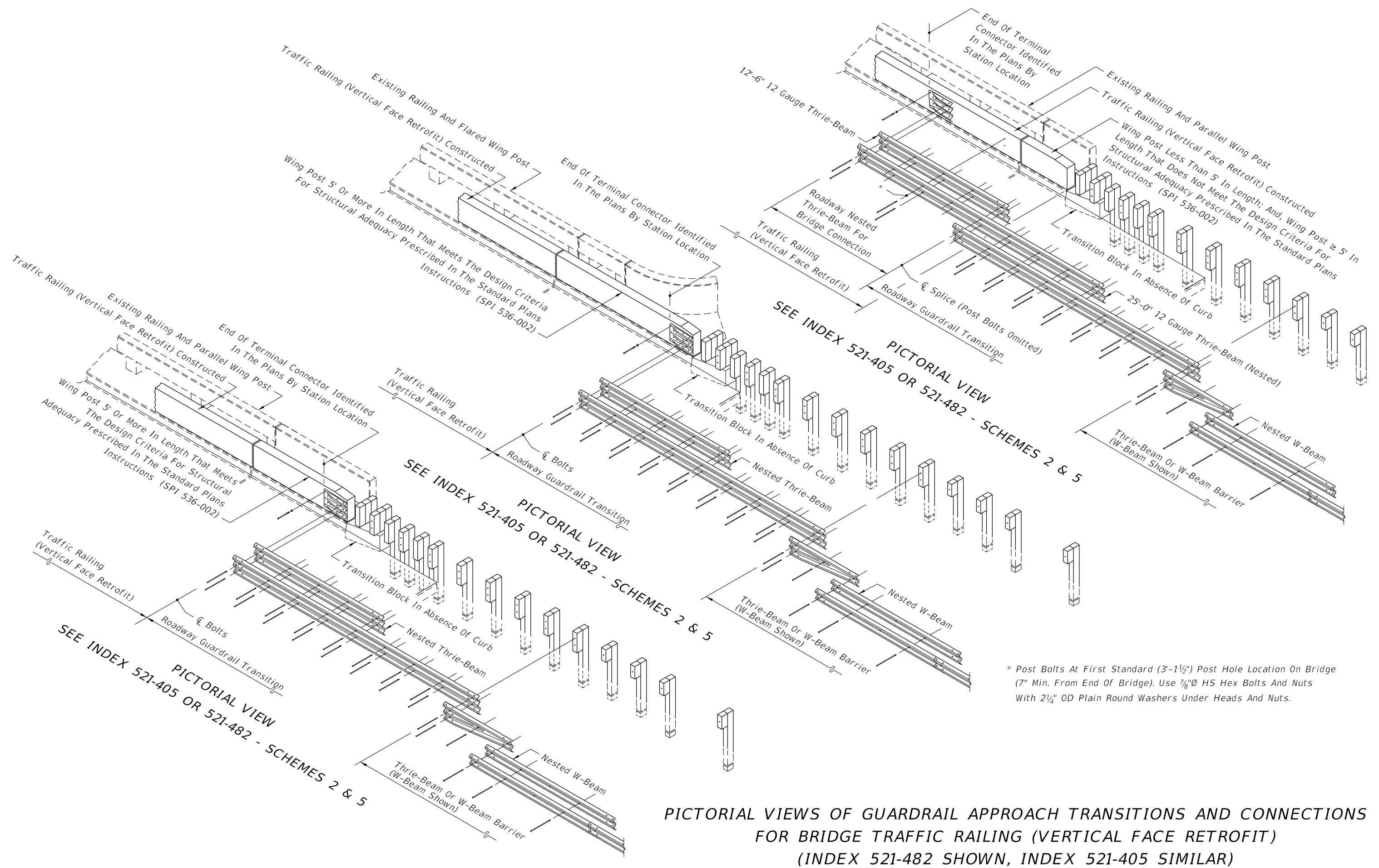

PICTORIAL VIEWS OF GUARDRAIL APPROACH TRANSITIONS AND CONNECTIONS FOR BRIDGE TRAFFIC RAILING (VERTICAL FACE RETROFIT) (INDEX 521-482 SHOWN, INDEX 521-405 SIMILAR)

10/20/2022 8:53:47 AM

LAST REVISION 11/01/19	REVISION DESCRIPTION:	 FY 2023-24 STANDARD PLANS	GUARDRAIL TRANSITIONS AND CONNECTIONS FOR EXISTING BRIDGES	INDEX 536-002	SHEET 21 of 28
---------------------------	-----------------------	---	--	------------------	-------------------

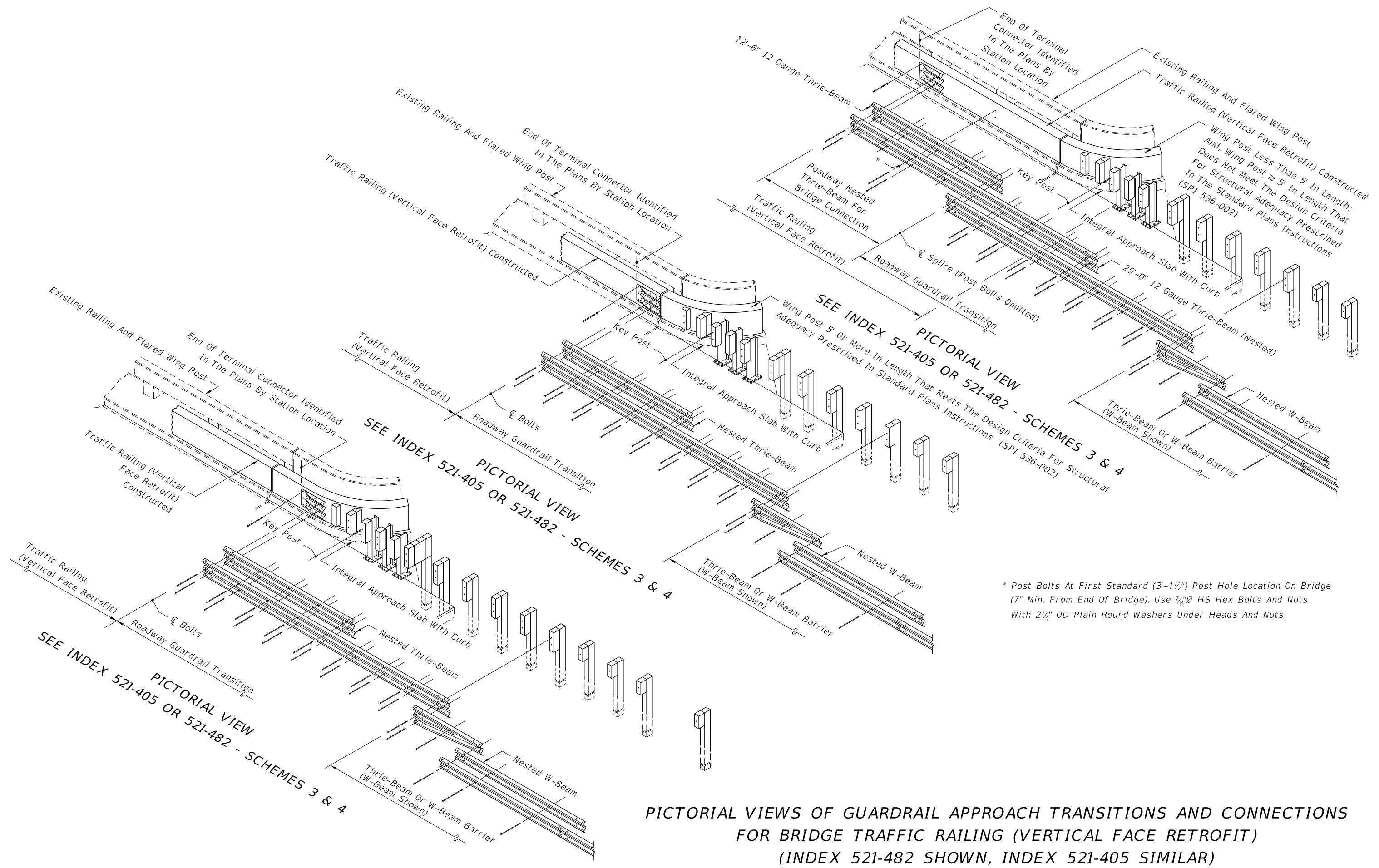

* Post Bolts At First Standard (3'-1 1/2") Post Hole Location On Bridge (7" Min. From End Of Bridge). Use 7/8" Ø HS Hex Bolts And Nuts With 2 1/4" OD Plain Round Washers Under Heads And Nuts.

PICTORIAL VIEWS OF GUARDRAIL APPROACH TRANSITIONS AND CONNECTIONS FOR BRIDGE TRAFFIC RAILING (VERTICAL FACE RETROFIT) (INDEX 521-482 SHOWN, INDEX 521-405 SIMILAR)

10/20/2022 8:53:48 AM

LAST REVISION 11/01/19	REVISION DESCRIPTION:	 FY 2023-24 STANDARD PLANS	GUARDRAIL TRANSITIONS AND CONNECTIONS FOR EXISTING BRIDGES	INDEX 536-002	SHEET 22 of 28
---------------------------	-----------------------	---	--	------------------	-------------------

10/20/2022 8:54:17 AM

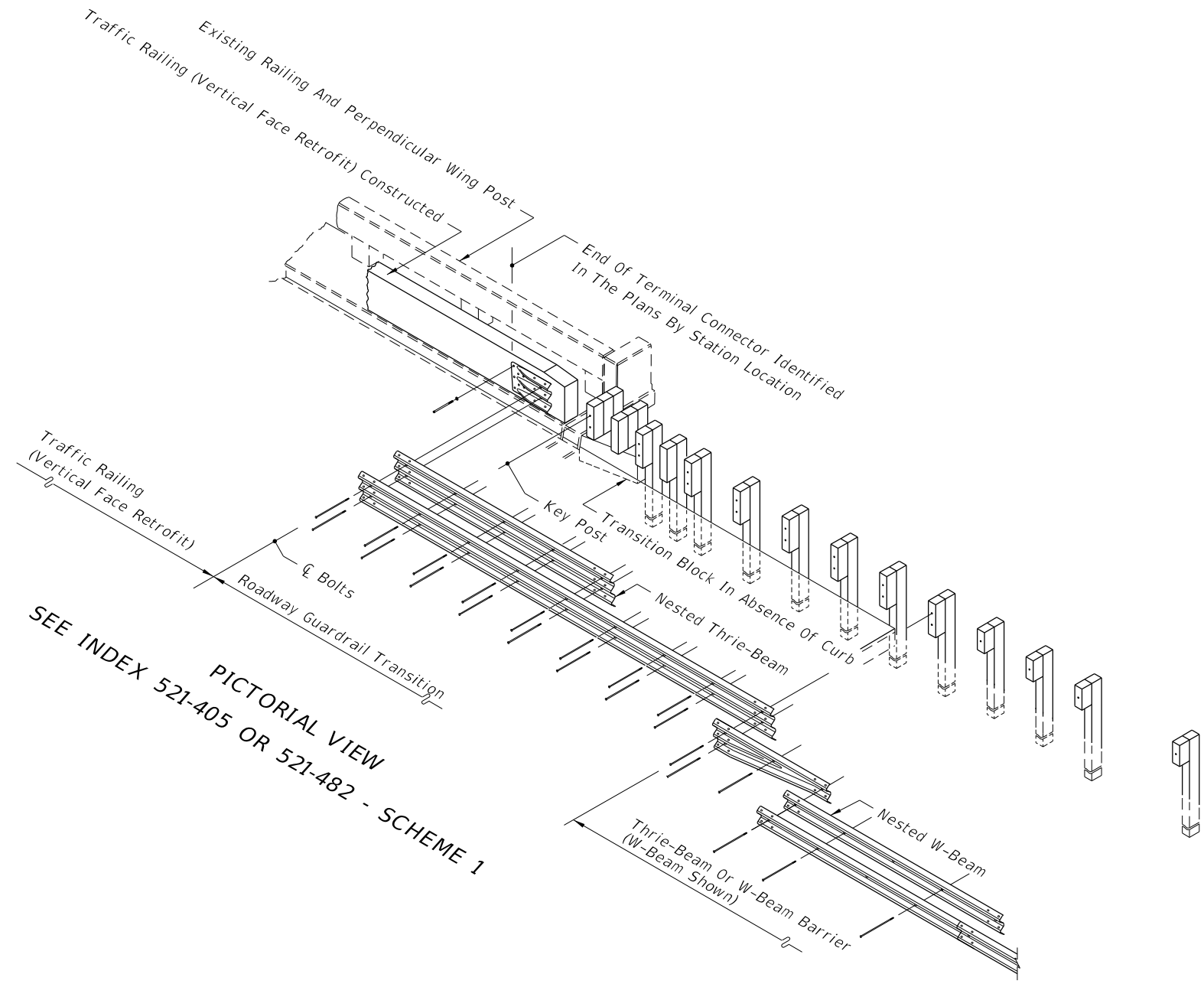

PICTORIAL VIEWS OF GUARDRAIL APPROACH TRANSITIONS AND CONNECTIONS FOR BRIDGE TRAFFIC RAILING (VERTICAL FACE RETROFIT) (INDEX 521-482 SHOWN, INDEX 521-405 SIMILAR)

LAST REVISION 11/01/19	DESCRIPTION:	 FY 2023-24 STANDARD PLANS	GUARDRAIL TRANSITIONS AND CONNECTIONS FOR EXISTING BRIDGES	INDEX 536-002	SHEET 23 of 28
---------------------------	--------------	---	--	------------------	-------------------

10/20/2022 8:54:18 AM

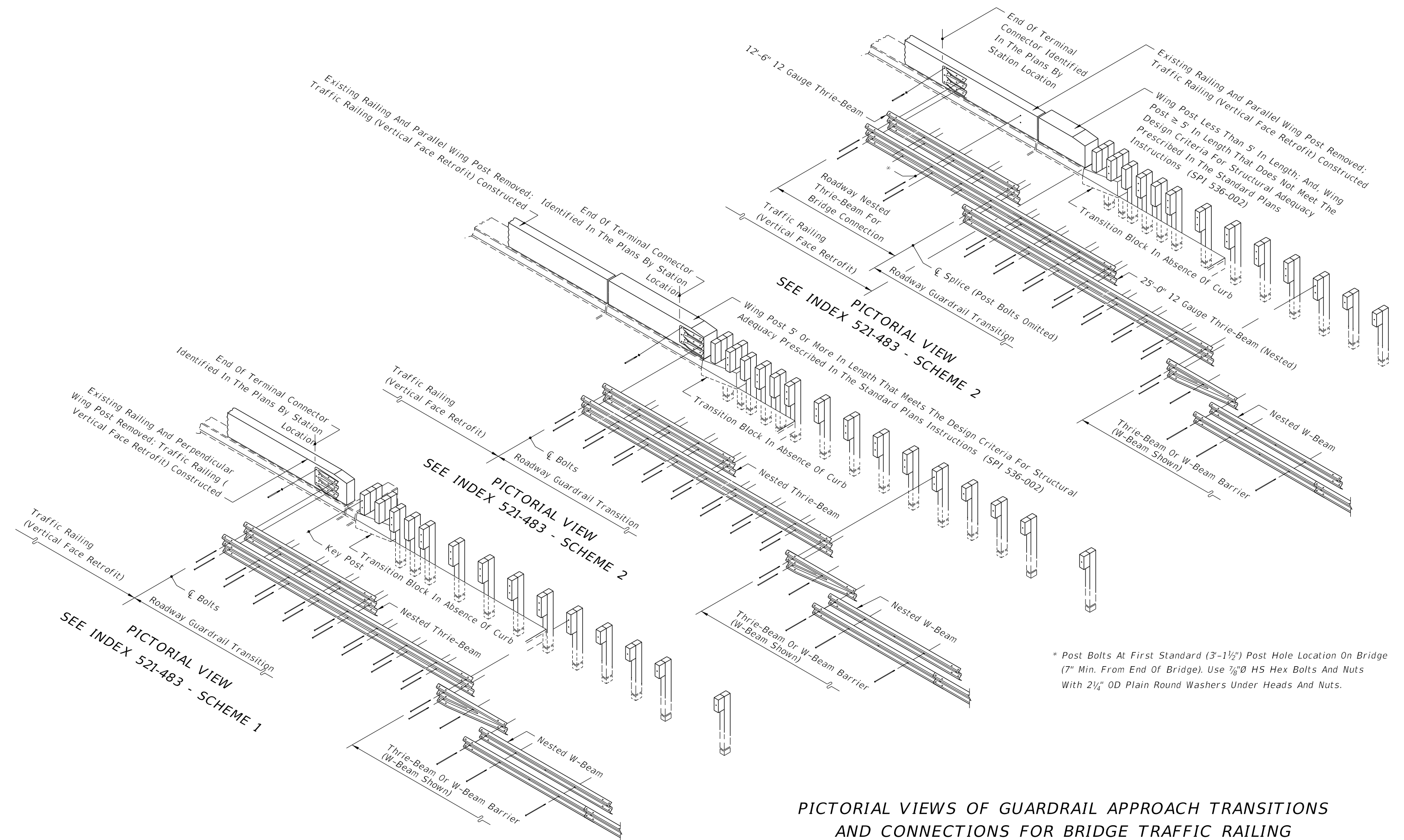

* Post Bolts At First Standard (3'-1 1/2") Post Hole Location On Bridge (7" Min. From End Of Bridge). Use 7/8"Ø HS Hex Bolts And Nuts With 2 1/4" OD Plain Round Washers Under Heads And Nuts.

PICTORIAL VIEWS OF GUARDRAIL APPROACH TRANSITIONS AND CONNECTIONS FOR BRIDGE TRAFFIC RAILING (VERTICAL FACE RETROFIT)

LAST REVISION 11/01/19	REVISION DESCRIPTION:	 FY 2023-24 STANDARD PLANS	GUARDRAIL TRANSITIONS AND CONNECTIONS FOR EXISTING BRIDGES	INDEX 536-002	SHEET 24 of 28
---------------------------	--------------------------	---	--	------------------	-------------------

10/20/2022 8:54:20 AM

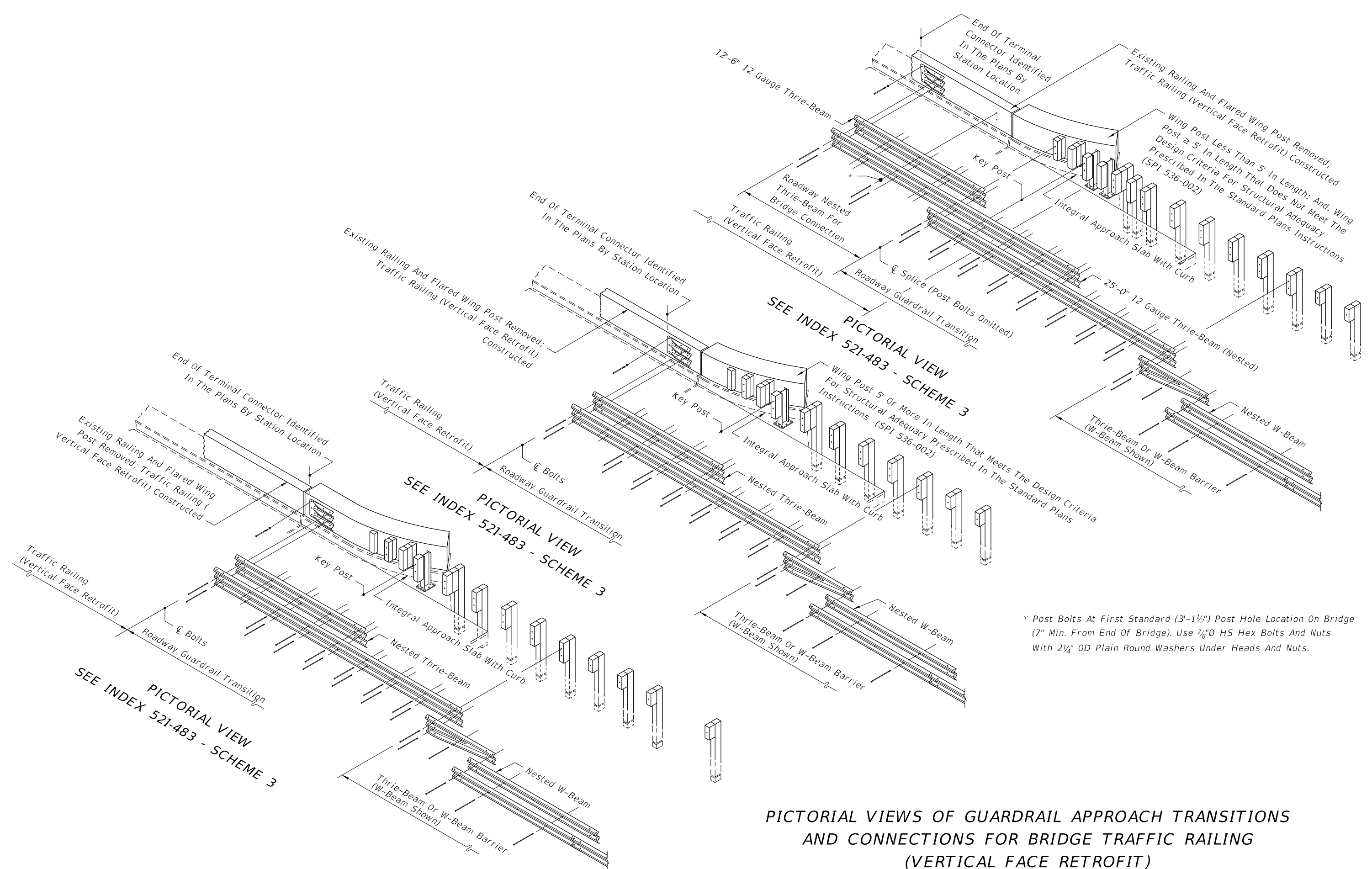

* Post Bolts At First Standard (3'-1 1/2") Post Hole Location On Bridge (7" Min. From End Of Bridge). Use 7/8"Ø HS Hex Bolts And Nuts With 2 1/4" OD Plain Round Washers Under Heads And Nuts.

PICTORIAL VIEWS OF GUARDRAIL APPROACH TRANSITIONS AND CONNECTIONS FOR BRIDGE TRAFFIC RAILING (VERTICAL FACE RETROFIT)

LAST REVISION 11/01/19	DESCRIPTION: 	 FY 2023-24 STANDARD PLANS	GUARDRAIL TRANSITIONS AND CONNECTIONS FOR EXISTING BRIDGES	INDEX 536-002	SHEET 25 of 28
---------------------------	----------------------	---	--	------------------	-------------------

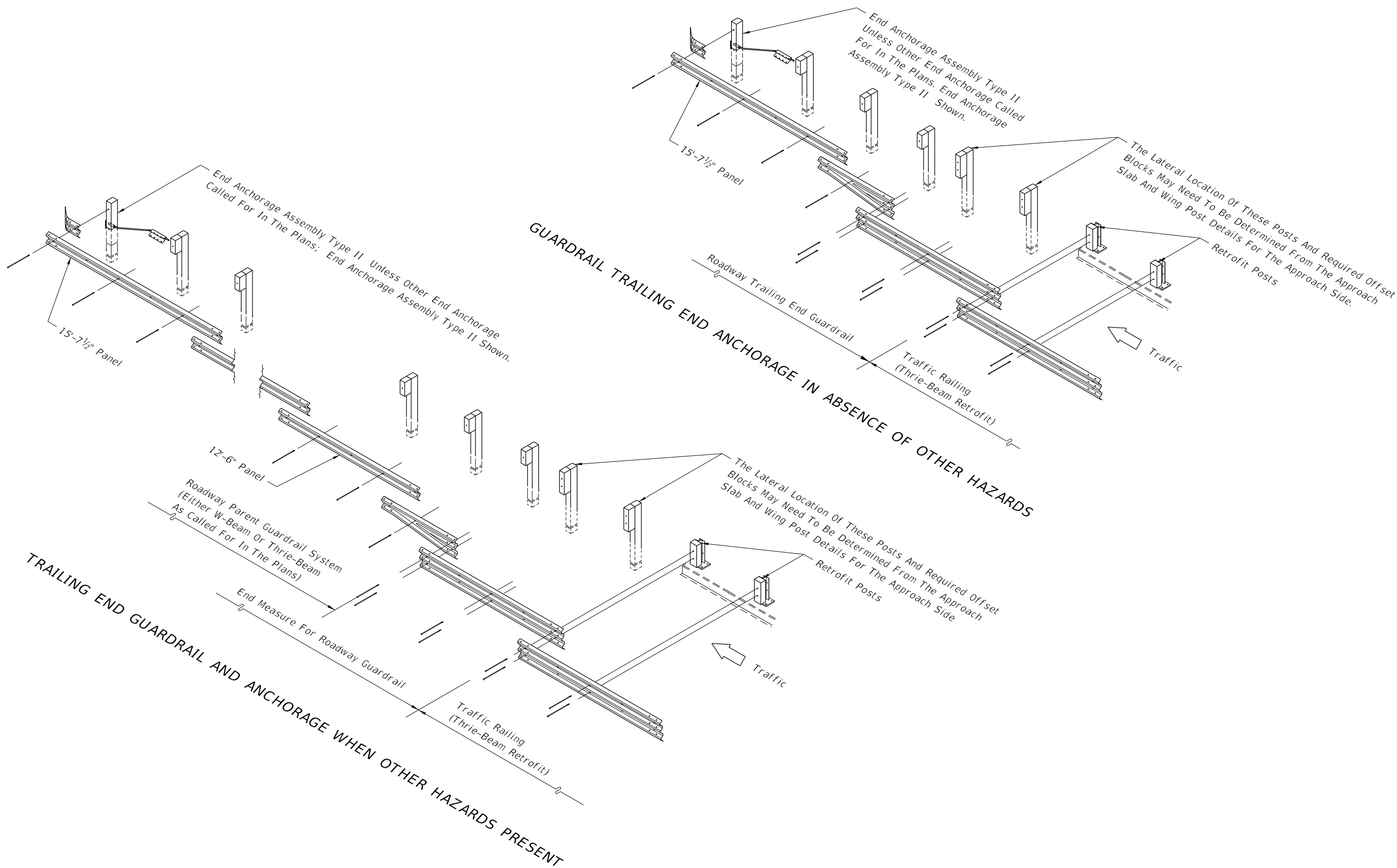

TRAILING END GUARDRAIL AND ANCHORAGE FOR BRIDGE TRAFFIC RAILING (THRIE BEAM RETROFITS)

10/20/2022 8:54:21 AM

LAST REVISION 11/01/19	REVISION DESCRIPTION:	 FY 2023-24 STANDARD PLANS	GUARDRAIL TRANSITIONS AND CONNECTIONS FOR EXISTING BRIDGES	INDEX 536-002	SHEET 26 of 28
---------------------------	-----------------------	--	--	------------------	-------------------

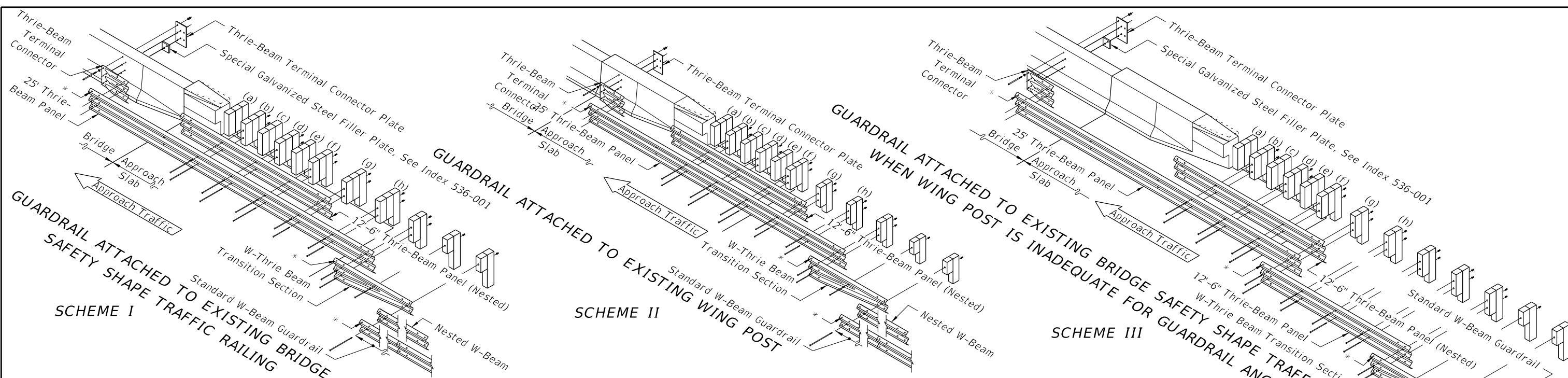

Use Of Scheme I Shall Be Determined
 In Accordance With The Standard Plans Instructions (SPI 536-002).
GUARDRAIL TRANSITION TO EXISTING FLAT SLAB BRIDGES

* Splice Locations: Thrie-Beam - 12 Guardrail Splice Bolts And Recessed Nuts
 W-Beam - 8 Guardrail Splice Bolts And Recessed Nuts
 Use Of Schemes II And III Shall Be Determined In Accordance With The Standard Plans Instructions (SPI 536-002).
GUARDRAIL TRANSITIONS TO EXISTING PRESTRESSED BEAM OR GIRDER BRIDGES

APPROACH POSTS AND SPECIAL OFFSET BLOCKS

Block assemblies for special offsets can be made up of one special block plus one standard size block or of three standard size blocks field dressed to approximately equal size, with the pieces secured for relative position by 16d galvanized nails, see '16d NAIL FOR PREVENTION OF OFFSET BLOCK ROTATION' - Index 536-001. The nested rails shall not be bolted to the blocks and posts at posts (a), (c) and (e). The details shown are for approach slabs with internal edge dike extending beyond parapet type traffic railing termini.

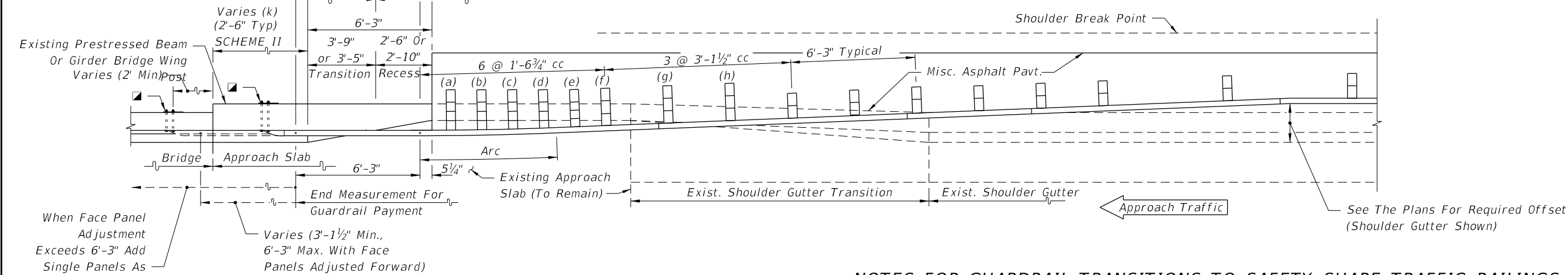

PLAN

NOTES FOR GUARDRAIL TRANSITIONS TO SAFETY SHAPE TRAFFIC RAILINGS ON EXISTING BRIDGES

- When the guardrail attachment overlays the Bridge Number, Bridge Name or Date on the traffic railing, provide an aluminum sign panel with the obscured information. Attach the sign panel to the face of the traffic railing adjacent to the Thrie-Beam Terminal Connector with 1/4"Ø x 1" long concrete screws or expansion anchors at each corner, as approved by the Engineer. The sign panel shall be a minimum 1/16" thick and meet the requirements of Specification 700 with a white background and 3" tall black letters and sized appropriately to contain the information required. The cost of the sign panel shall be included in the cost of the Guardrail Bridge Anchorage Assembly.
- When retrofitting thrie-beam guardrail to existing wing posts or existing bridge safety shape traffic railing, attachment construction to be paid for under the contract unit price for Guardrail Bridge Anchorage Assembly, EA., and shall be full compensation for bolt hole construction, terminal connector, terminal connector plate(s) and bolts, nuts and washers.

GUARDRAIL APPROACH TRANSITION CONNECTIONS FOR EXISTING FLAT SLAB, PRESTRESSED BEAM AND GIRDER BRIDGES WITH SAFETY SHAPE TRAFFIC RAILING EXTENDING LESS THAN FULL APPROACH SLAB LENGTH

LAST REVISION 11/01/19	DESCRIPTION:	 FY 2023-24 STANDARD PLANS	GUARDRAIL TRANSITIONS AND CONNECTIONS FOR EXISTING BRIDGES	INDEX 536-002	SHEET 27 of 28
---------------------------	--------------	----------------------------------	---	------------------	-------------------

10/20/2022 8:54:22 AM

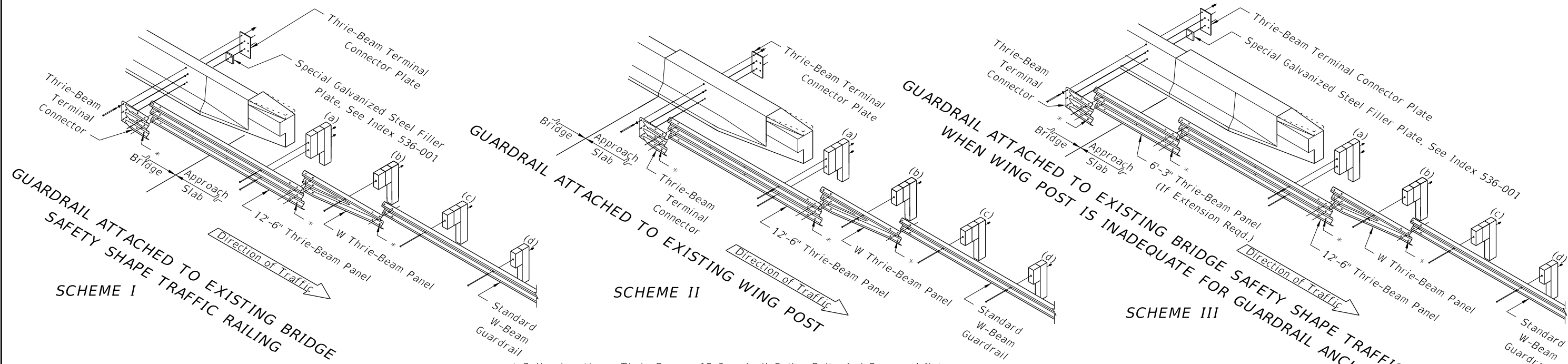

Use Of Scheme I Shall Be Determined In Accordance With The Standard Plans Instructions (SPI 536-002).
GUARDRAIL TRANSITION TO EXISTING FLAT SLAB BRIDGES

* Splice Locations: Thrie-Beam - 12 Guardrail Splice Bolts And Recessed Nuts
 W-Beam - 8 Guardrail Splice Bolts And Recessed Nuts
 Use Of Schemes II And III Shall Be Determined In Accordance With The Standard Plans Instructions (SPI 536-002).
GUARDRAIL TRANSITIONS TO EXISTING PRESTRESSED BEAM OR GIRDER BRIDGES

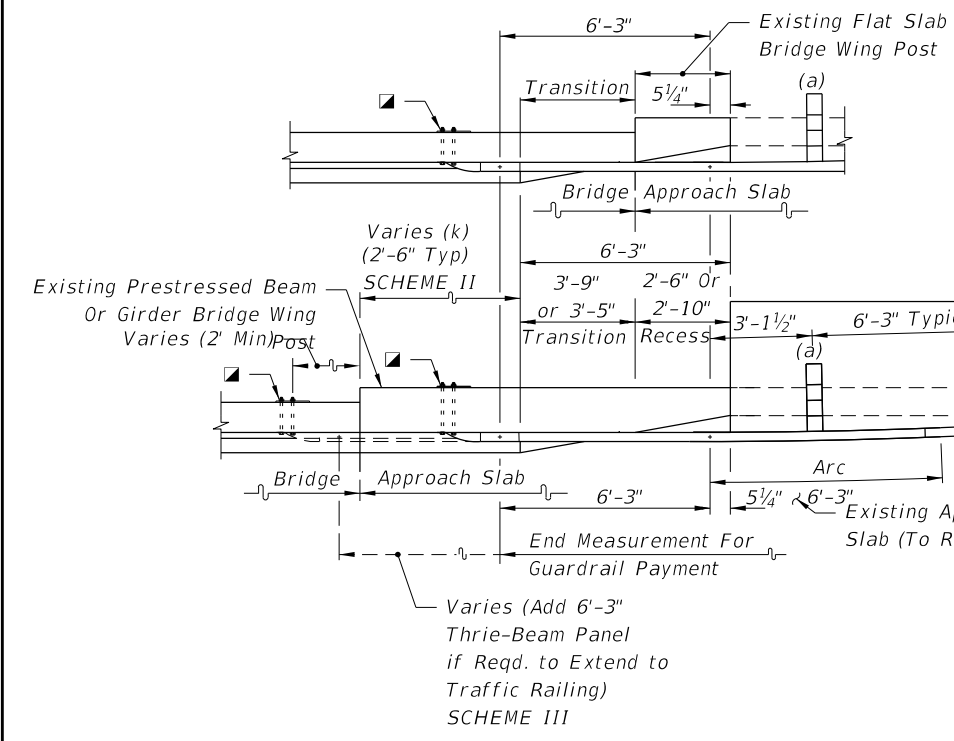

TRAILING END POSTS AND SPECIAL OFFSET BLOCKS
 Block assemblies for special offsets can be made up of one special block plus one standard size block or of three standard size blocks field dressed to approximately equal size, with the pieces secured for relative position by 16d galvanized nails, see '16d NAIL FOR PREVENTION OF OFFSET BLOCK ROTATION' - Index 536-001. The nested rails shall not be bolted to the blocks and posts at posts (a), (c) and (e). The details shown are for approach slabs with internal edge dike extending beyond parapet type traffic railing termini.

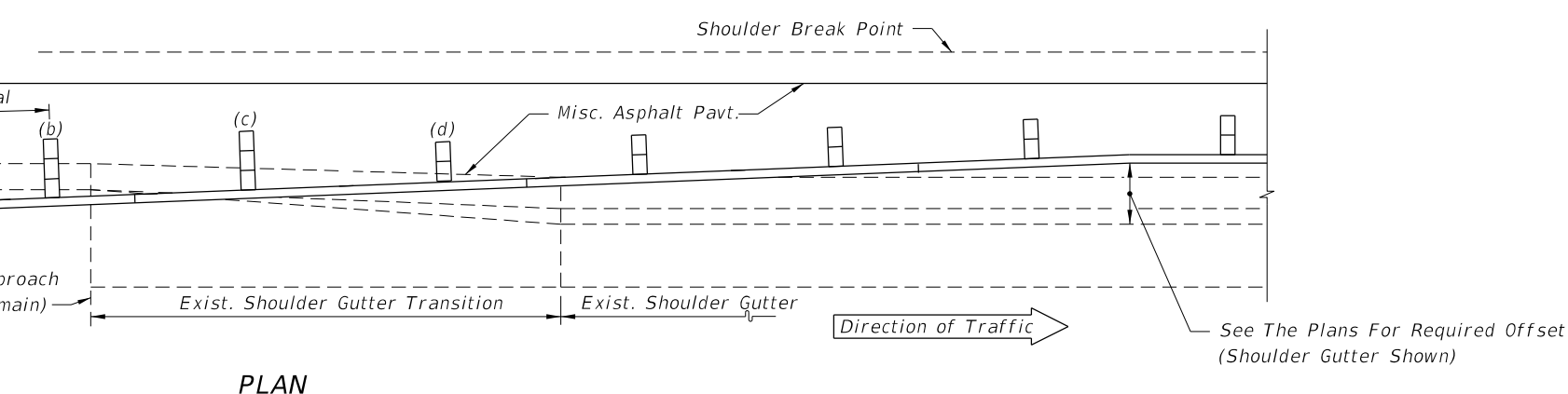

PLAN

NOTES FOR GUARDRAIL TRANSITIONS TO SAFETY SHAPE TRAFFIC RAILINGS ON EXISTING BRIDGES

1. When the guardrail attachment overlays the Bridge Number, Bridge Name or Date on the traffic railing, provide an aluminum sign panel with the obscured information. Attach the sign panel to the face of the traffic railing adjacent to the Thrie-Beam Terminal Connector with 1/4"Ø x 1" long concrete screws or expansion anchors at each corner, as approved by the Engineer. The sign panel shall be a minimum 1/16" thick and meet the requirements of Specification 700 with a white background and 3" tall black letters and sized appropriately to contain the information required. The cost of the sign panel shall be included in the cost of the Guardrail Bridge Anchorage Assembly.
2. When retrofitting thrie-beam guardrail to existing wing posts or existing bridge safety shape traffic railing, attachment construction to be paid for under the contract unit price for Guardrail Bridge Anchorage Assembly, EA., and shall be full compensation for bolt hole construction, terminal connector, terminal connector plate(s) and bolts, nuts and washers.

GUARDRAIL TRAILING END TRANSITION CONNECTIONS FOR EXISTING FLAT SLAB, PRESTRESSED BEAM AND GIRDER BRIDGES WITH SAFETY SHAPE TRAFFIC RAILING EXTENDING LESS THAN FULL APPROACH SLAB LENGTH

LAST REVISION 11/01/19	DESCRIPTION:  FY 2023-24 STANDARD PLANS	GUARDRAIL TRANSITIONS AND CONNECTIONS FOR EXISTING BRIDGES	INDEX 536-002	SHEET 28 of 28
---------------------------	---	--	------------------	-------------------

10/20/2022 8:54:23 AM

GENERAL NOTES:

1. **GENERAL:** Work this Index in accordance with Specification 544 and the "Summary of Permanent Crash Cushions" table in the Plans. Where applicable, use Guardrail components and panel lap splices in accordance with Index 536-001.

2. **TRANSITION PANEL:** Where crash cushions are placed between two-way traffic or adjacent to two-way two-lane traffic, place a Transition Panel from the Concrete Barrier to the Crash Cushion on the downstream side of the barrier end (as shown). Follow the requirements of the APL drawing.

3. **MANUFACTURER'S TRANSITION:** Construct the proprietary guardrail transition only if shown in the applicable APL drawing. See Note 4 below.

4. **STANDARD GUARDRAIL TRANSITION:** If the APL drawing does not provide a guardrail transition to w-beam guardrail, construct the Standard Guardrail Transition segment from thrie-beam to w-beam as shown per Sheet 2. This 21'-10 1/2" segment must remain parallel to the roadway.

If the APL drawing does provide a guardrail transition to w-beam guardrail, replace the Standard Guardrail Transition segment with a w-beam guardrail segment at 6'-3" post spacing, except that Post (10) will remain where shown herein if it is located at a guardrail begin or end taper station callout per the Plans. This 21'-10 1/2" segment must also remain parallel to the roadway.

5. **LENGTH OF END TREATMENT:** For Crash Cushions, the Length of End Treatment includes all proprietary elements of the design as shown in the APL drawing, including the manufacturer's transition of guardrail if applicable.

The actual Length of End Treatment varies per Crash Cushion type, but an estimated Length of End Treatment is generally shown in the Plans to provide sufficient space for the Contractor's option of differing Crash Cushion types.

6. **LENGTH RESTRICTION:** In the "Summary of Permanent Crash Cushions" table, if a value is provided in the Length Restriction column, then select a Crash Cushion from the APL which has a Length of End Treatment less than or equal to the value shown. If the table instead shows not applicable (N/A), then Crash Cushion selection is unrestricted regarding length.

7. **CRASH CUSHION STATION:** The Crash Cushion Station point shown herein corresponds to the station provided in the "Summary of Permanent Crash Cushions" table in the Plans.

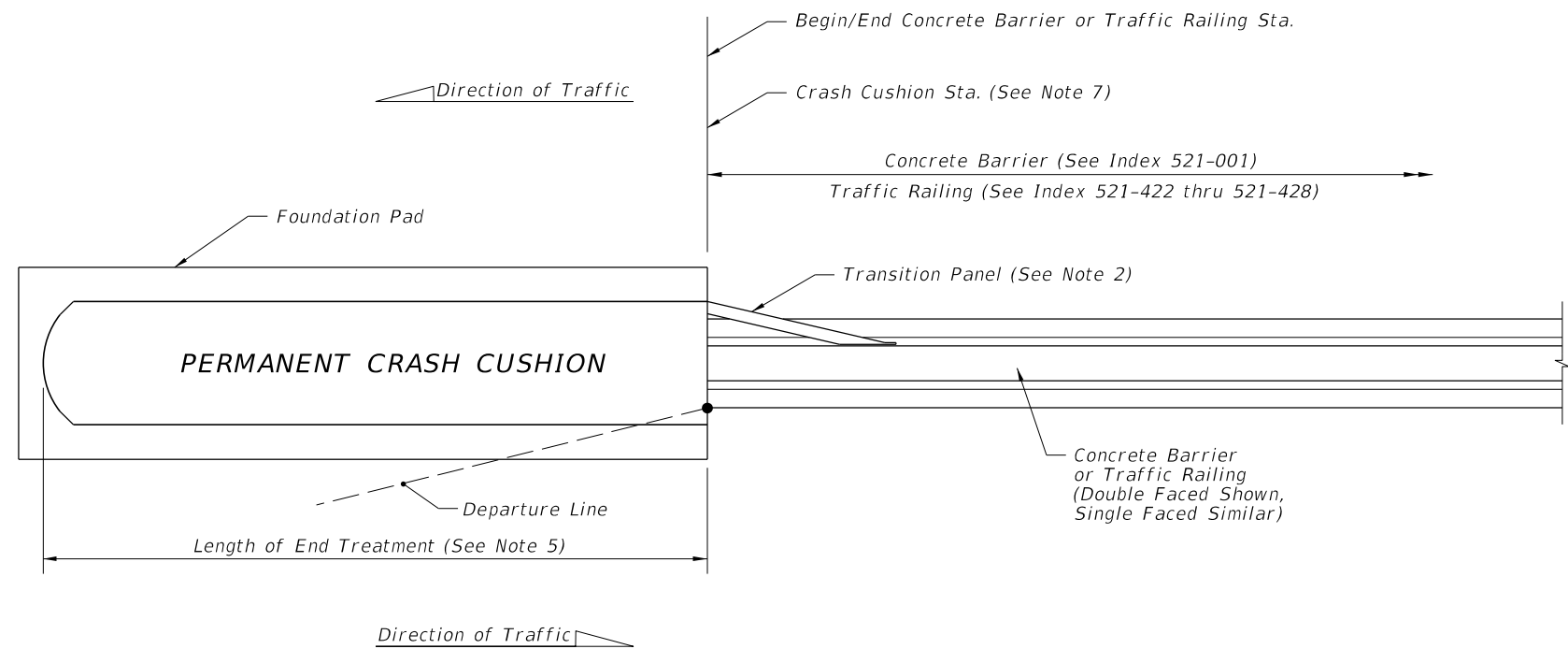

CONCRETE BARRIER APPLICATION

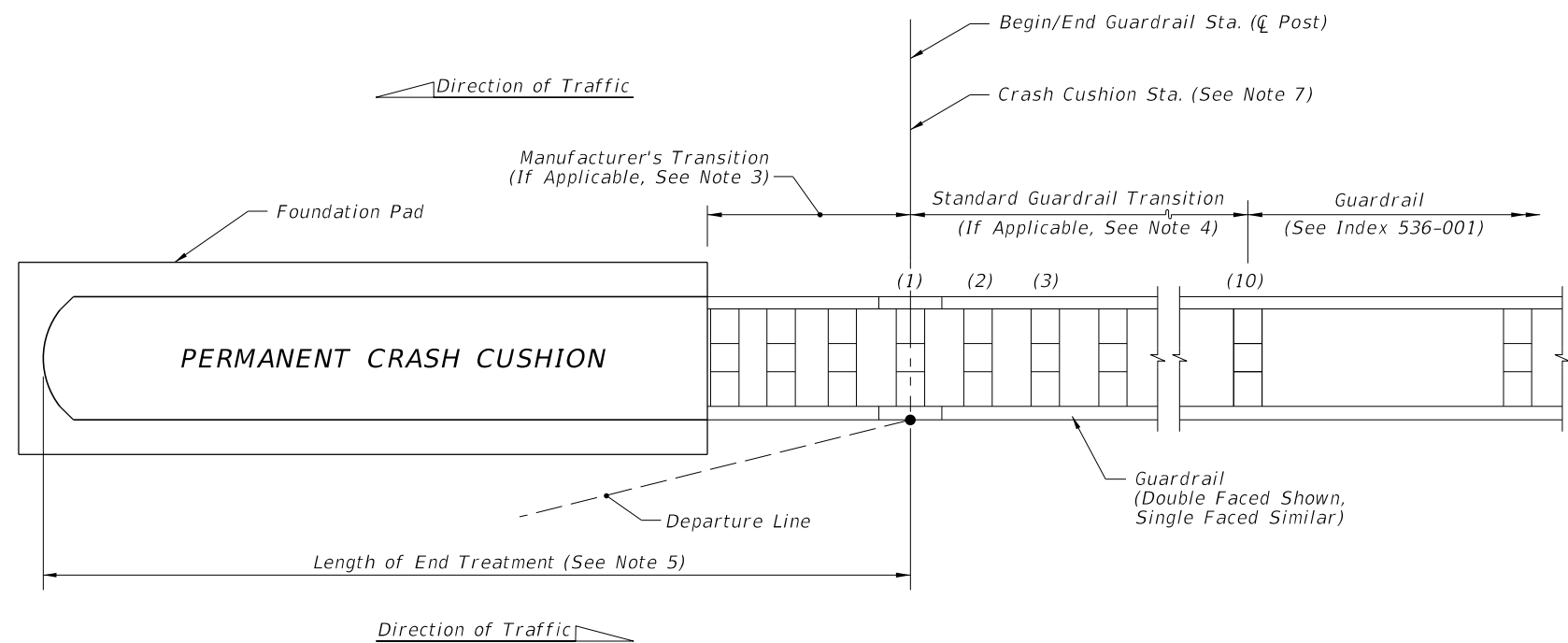

GUARDRAIL APPLICATION

PERMANENT CRASH CUSHION APPLICATIONS

10/20/2022 8:54:24 AM

LAST REVISION 11/01/19	REVISION	DESCRIPTION:		FY 2023-24 STANDARD PLANS	CRASH CUSHION DETAILS	INDEX 544-001	SHEET 1 of 3
---------------------------	----------	--------------	---	------------------------------	-----------------------	------------------	-----------------

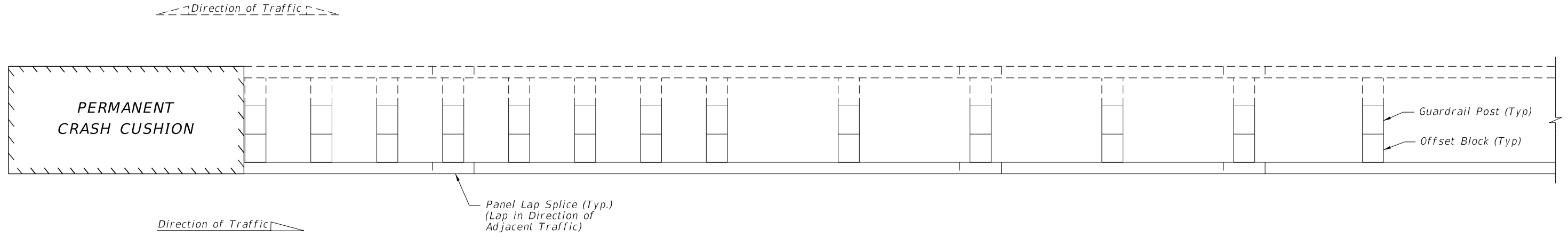

PLAN VIEW

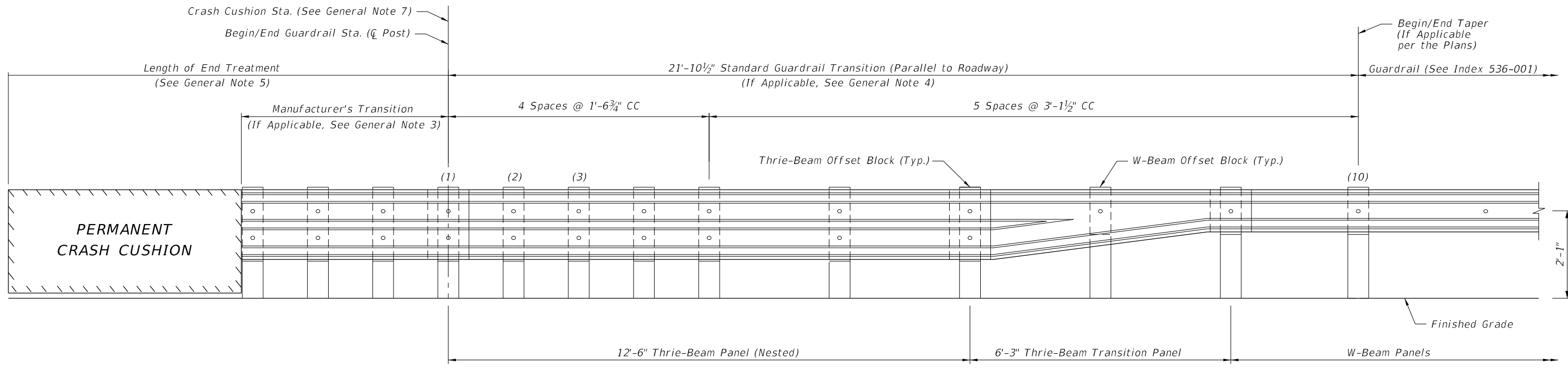

ELEVATION VIEW

NOTE:
Work this Sheet with the details and General Notes on Sheet 1.

STANDARD GUARDRAIL TRANSITION

10/20/2022 8:54:24 AM

LAST REVISION 11/01/19	REVISION	DESCRIPTION:	 FY 2023-24 STANDARD PLANS	CRASH CUSHION DETAILS	INDEX 544-001	SHEET 2 of 3
---------------------------	----------	--------------	--	-----------------------	------------------	-----------------

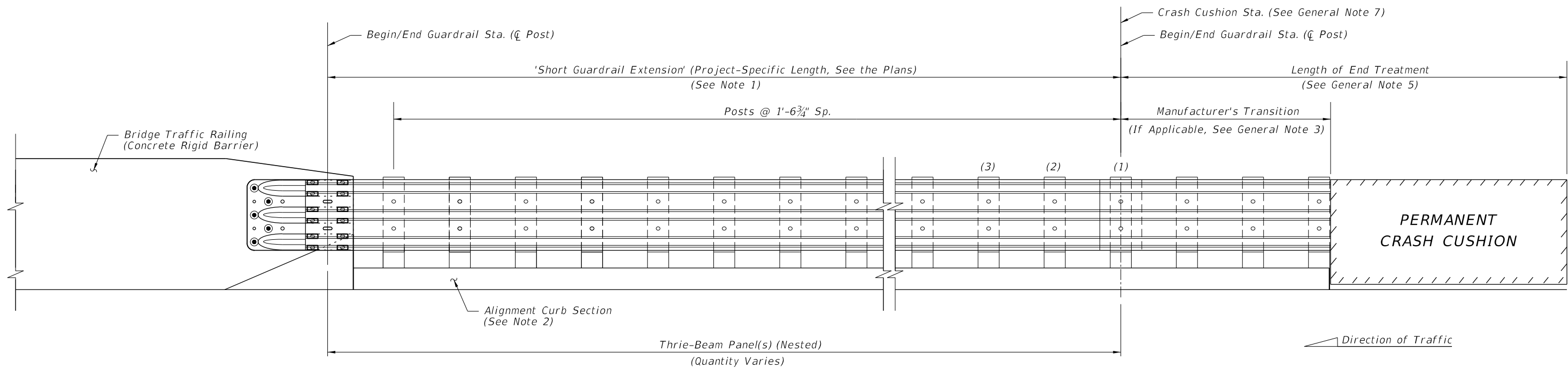

ELEVATION - CONNECTION TO CONCRETE TRAFFIC RAILING (See Note 2)

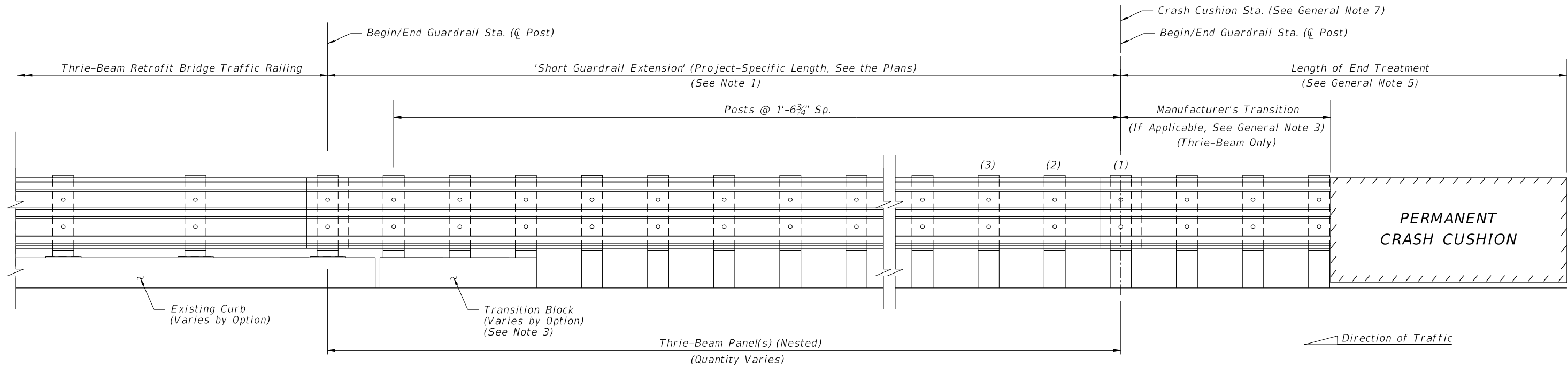

ELEVATION - CONNECTION TO THRIE-BEAM RETROFIT (See Note 3)

NOTES:

1. GENERAL: Work this Sheet with the details and General Notes on Sheet 1.

Install short guardrail extension only where called for in the plans, using the project-specific length specified. Short guardrail extensions are typically used where adding length to a barrier system is warranted, but a full Approach Transition Connection to Rigid Barrier will not fit.
2. CONNECTION TO CONCRETE TRAFFIC RAILING: See Index 536-001 for connection details to rigid barrier, including the Thrie-Beam Terminal Connector and Alignment Curb details. Install the Alignment Curb section with no curb transition, and extend the curb to the crash cushion as shown. The crash cushion must laterally extend beyond the above-ground portion of the alignment curb to shield its end face from approaching traffic.
3. CONNECTION TO THRIE-BEAM RETROFIT: Provide Thrie-Beam Retrofit guardrail connection splice, curb, and Transition Block per Index 536-002 and the applicable Index 460-470 series.

**ADDITIONAL BRIDGE CONNECTION OPTIONS
SHORT GUARDRAIL EXTENSIONS**

10/20/2022 8:54:25 AM

LAST REVISION 11/01/19	REVISION	DESCRIPTION:		FY 2023-24 STANDARD PLANS	CRASH CUSHION DETAILS	INDEX 544-001	SHEET 3 of 3
---------------------------	----------	--------------	---	------------------------------	-----------------------	------------------	-----------------

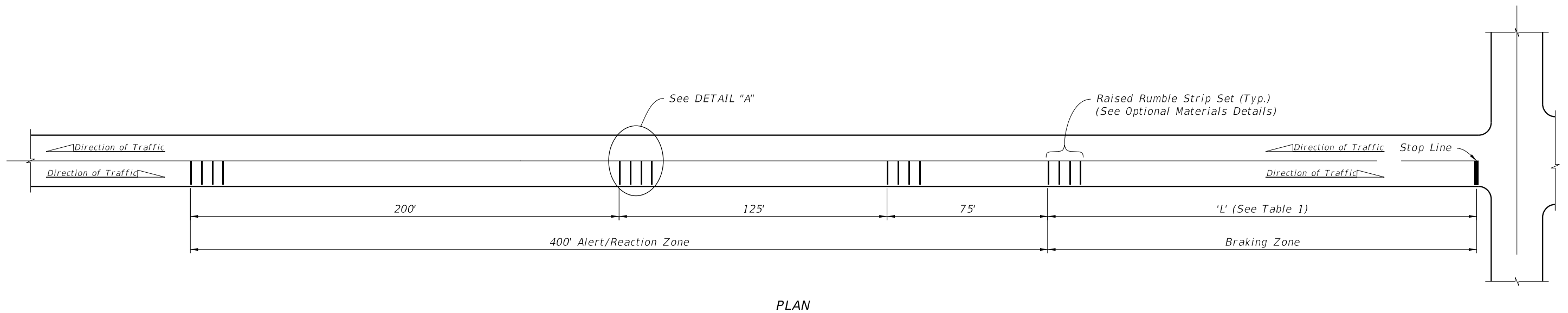

SPACING OF RAISED RUMBLE STRIP SETS AT INTERSECTIONS
(Preformed Thermoplastic Set Shown, Others Similar)

TABLE 1 - BRAKING ZONE	
Posted Speed (mph)	'L' (Feet)
≤ 30	150
35	200
40	250
45	300
50	350
55	410
60	470
65	550

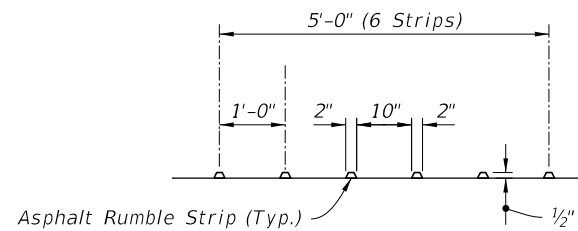

OPTION P1 - ASPHALT SET

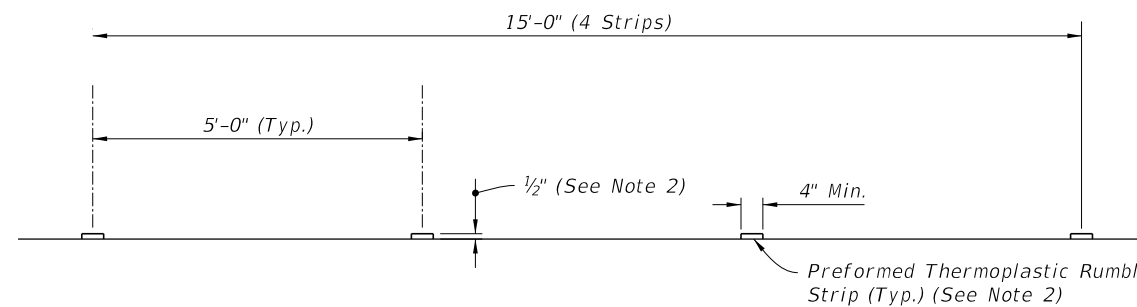

OPTION P2 - PREFORMED THERMOPLASTIC SET

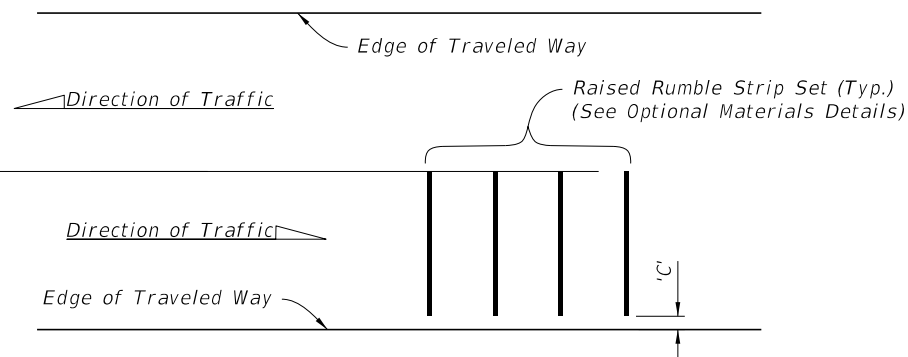

'C' = 0' For Roadways With Paved Shoulders
'C' = 1.5' For Roadways Without Paved Shoulders

DETAIL "A"

OPTIONAL MATERIALS DETAILS

NOTES:

- Construct permanent raised rumble strips where shown in the Plans and in accordance with Specification 546.
- Preformed Thermoplastic Set:
 - Use multiple applications to achieve desired 1/2" thickness.
 - Use color white.

PERMANENT RAISED RUMBLE STRIPS

10/20/2022 8:54:27 AM

LAST REVISION 04/23/18	REVISION	DESCRIPTION:	 FY 2023-24 STANDARD PLANS	RAISED RUMBLE STRIPS	INDEX 546-001	SHEET 1 of 2
---------------------------	----------	--------------	----------------------------------	----------------------	------------------	-----------------

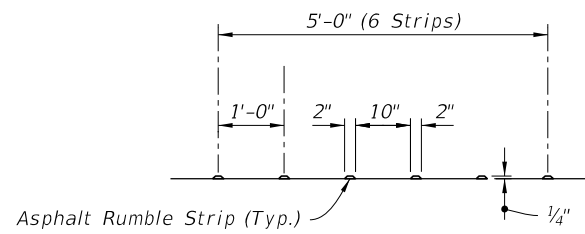

OPTION ST1 - ASPHALT SET

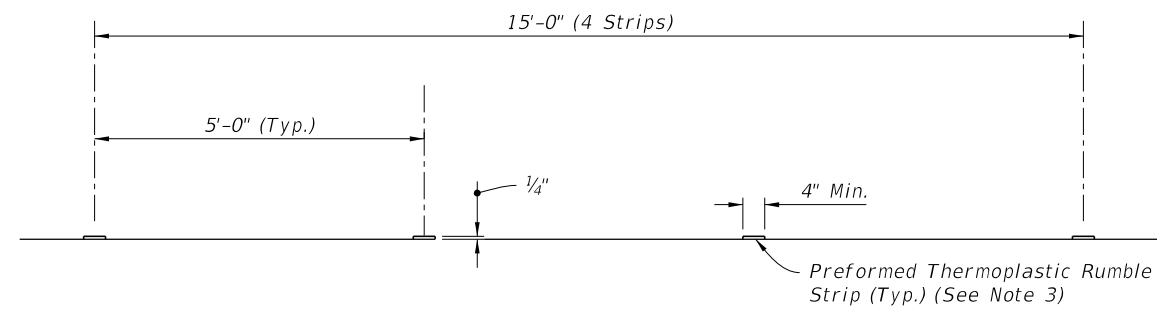

OPTION ST2 - PREFORMED THERMOPLASTIC SET

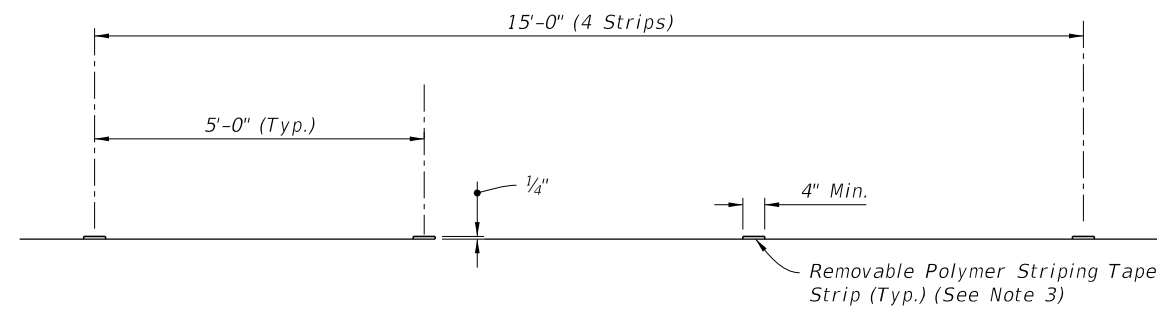

OPTION ST3 - REMOVABLE POLYMER STRIPING TAPE SET

OPTIONAL MATERIALS DETAILS

NOTES:

1. Construct short-term raised rumble strips where noted in the Plans and in accordance with Specification 546.
2. See Sheet 1 for placement and additional details.
3. Use color white for Preformed Thermoplastic and Removable Polymer Striping Tape Sets.

10/20/2022 8:54:27 AM

SHORT-TERM RAISED RUMBLE STRIPS

LAST REVISION 04/23/18	REVISION	DESCRIPTION:	 FY 2023-24 STANDARD PLANS	RAISED RUMBLE STRIPS	INDEX 546-001	SHEET 2 of 2
---------------------------	----------	--------------	---	----------------------	------------------	-----------------

NOTES:

1. When friction course extends more than 8" beyond the edge of the traveled way, blade off the extended friction course to the 8" line prior to rumble strip grinding.
2. Use the continuous array on both inside and outside shoulders 1,000 feet in advance of bridge ends or back to the gore recovery area for mainline interchange bridges. Use the skip array for all other locations.
3. Exclude rumble strips at the following locations:
 - A. At mainline tolling areas, terminate rumble strips at the end of the mainline normal section.
 - B. At All Electronic Tolling (AET) facilities, terminate rumble strips within 50 feet of the centerline of the overhead gantry.
 - C. On outside shoulders of entrance ramp terminals, terminate rumble strips at the point of the physical gore and resume at the end of the acceleration lane taper.
 - D. On outside shoulders of exit ramp terminals, terminate rumble strips at the start of the deceleration lane taper and resume at the point of the physical gore.
 - E. On approaches to bridges, terminate rumble strips at the approach slab joint.

RUMBLE STRIP DEPTH TABLE	
LOCATION	DEPTH FROM SURFACE (IN.)
A	0
B	$\frac{9}{16}$ ($\pm\frac{1}{16}$)

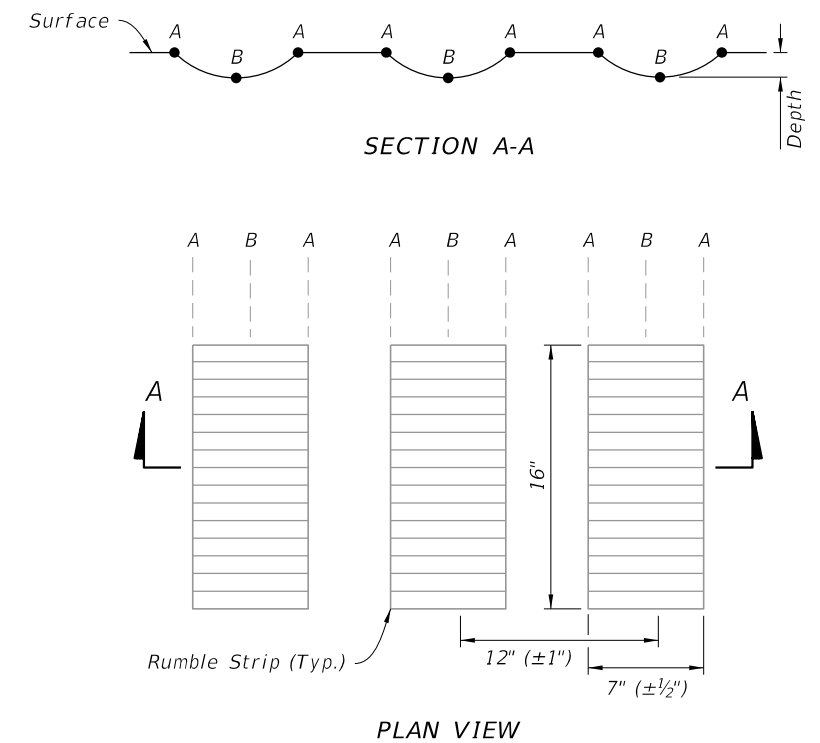
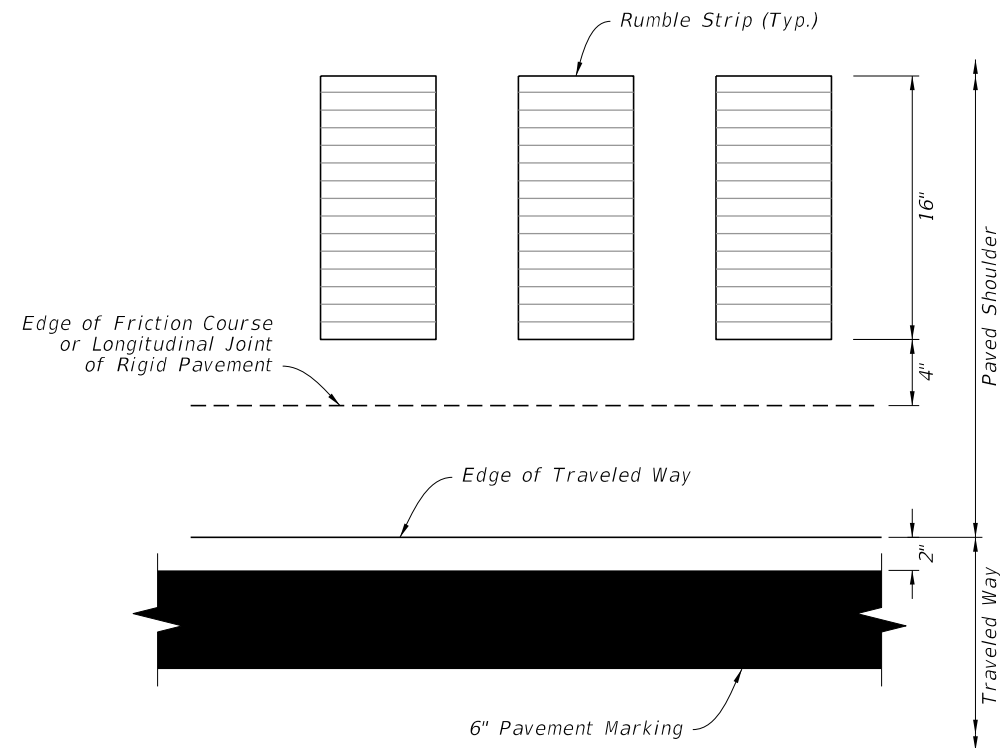

RUMBLE STRIP PLACEMENT
(Plan View)

RUMBLE STRIP DETAILS

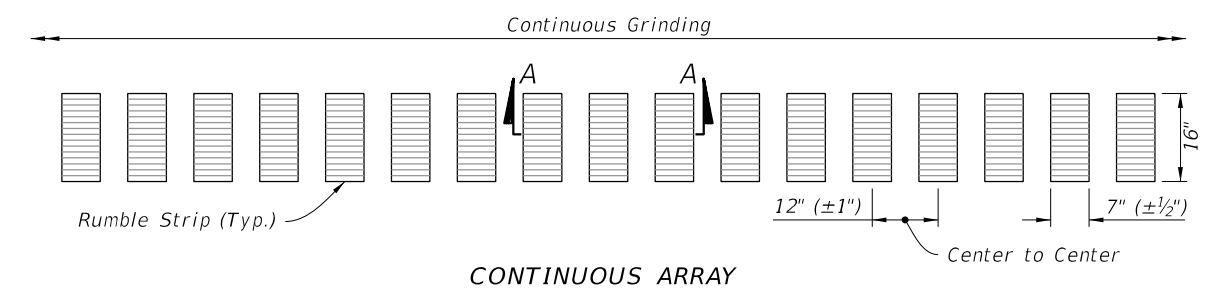
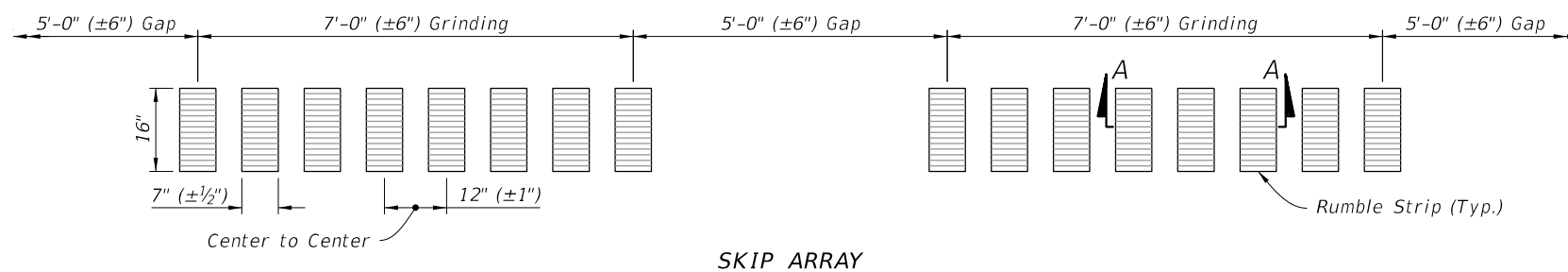

RUMBLE STRIP ARRAY DETAILS

10/20/2022 8:54:28 AM

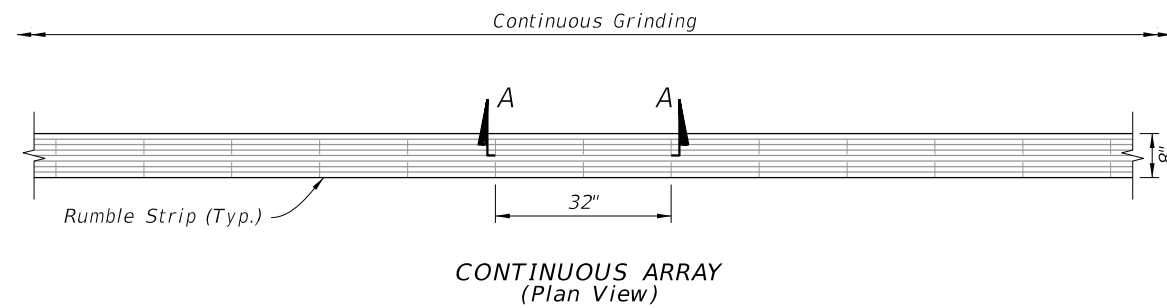
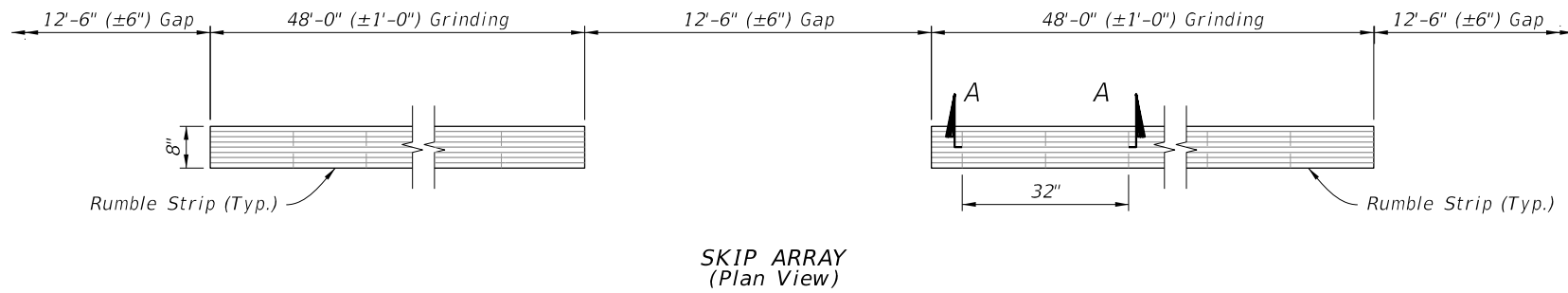

**TABLE 2
RUMBLE STRIP DEPTH**
(Depth Tolerance = $\pm\frac{1}{16}$)

LOCATION	DEPTH FROM SURFACE (IN.)
A	$\frac{1}{16}$
B	$\frac{9}{16}$

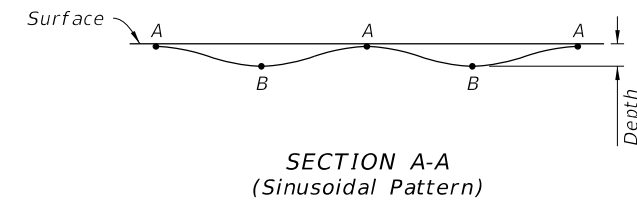

**TABLE 1
SKIP AND CONTINUOUS ARRAY APPLICATIONS**

Rumble Strip Placement	Array
Outside Shoulder with Buffered Bike Lane	Skip
Outside Paved Shoulder Width Greater than or Equal to 5'-0"	Skip
Outside Paved Shoulder Width Greater than 0'-0" and Less Than 5'-0"	Skip
Outside Paved Shoulder Equal to 0'-0"	Skip
Inside Paved Shoulder Width Greater Than or Equal to 1'-0"	Continuous
Inside Paved Shoulder Width Greater Than 0'-0" and Less Than 1'-0"	Skip
Inside Paved Shoulder Width Equal to 0'-0"	Skip
One - Direction Passing Centerline	Continuous (See Note 3)
Two - Direction Passing Centerline	Continuous (See Note 3)
Two - Direction No-Passing Centerline	Continuous

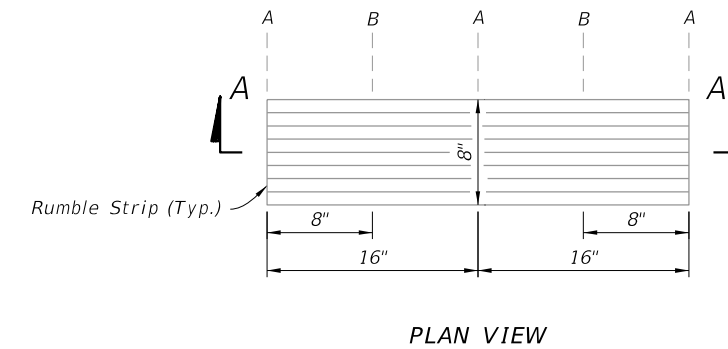

RUMBLE STRIP ARRAY DETAILS

RUMBLE STRIP DETAILS

GENERAL NOTES:

- Straightness tolerance of ground-in rumble strips in the roadway longitudinal direction is plus or minus 1/2".
- At intersections and major driveways:
 - Terminate outside shoulder rumble strips at the radius return.
 - Terminate median shoulder rumble strips at the radial return of median nose.
 - Terminate centerline rumble strips on undivided highways at the termination of centerline striping.
 - Terminate rumble strips at auxiliary lane tapers.
- For Centerlines in passing zones, provide 2 foot gaps in the continuous array spaced at 40 feet and centered on RPM locations.

12/22/2022 12:41:08 PM

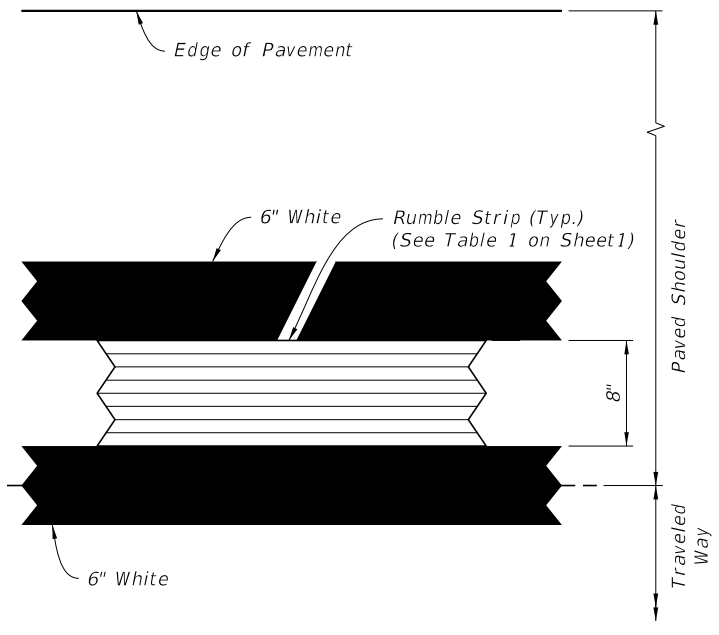

Outside Shoulder with Buffered Bike Lane

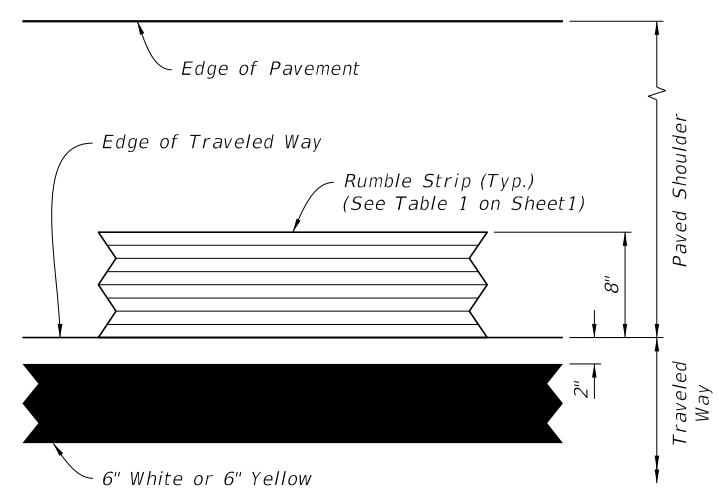

Outside Paved Shoulder Width
Greater Than or Equal to 5'-0"
or
Inside Paved Shoulder Width
Greater Than or Equal to 1'-0"

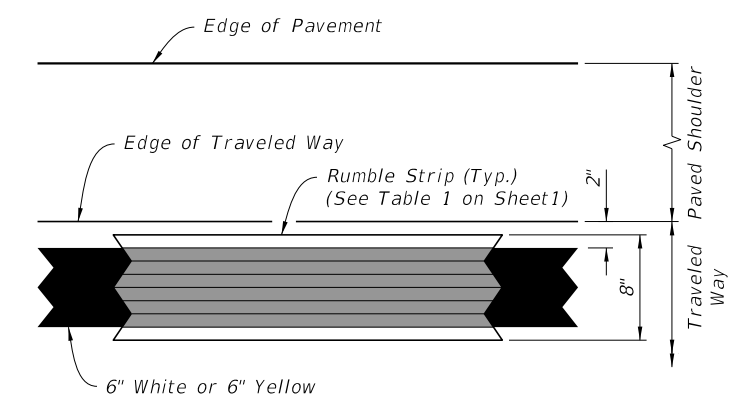

Outside Paved Shoulder Width
Greater Than 0'-0" and Less Than 5'-0"
or
Inside Paved Shoulder Width
Greater Than 0'-0" and Less Than 1'-0"

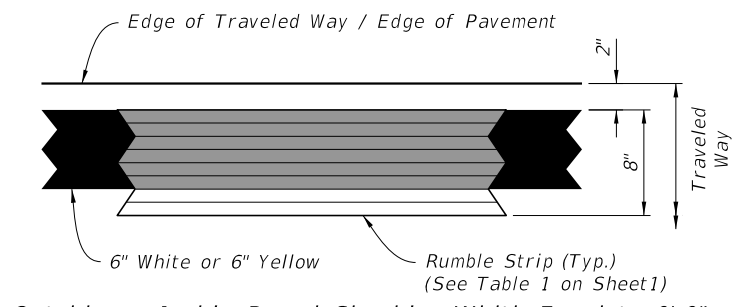

Outside or Inside Paved Shoulder Width Equal to 0'-0"

EDGE LINE AND SHOULDER RUMBLE STRIP PLACEMENT
(Plan View)

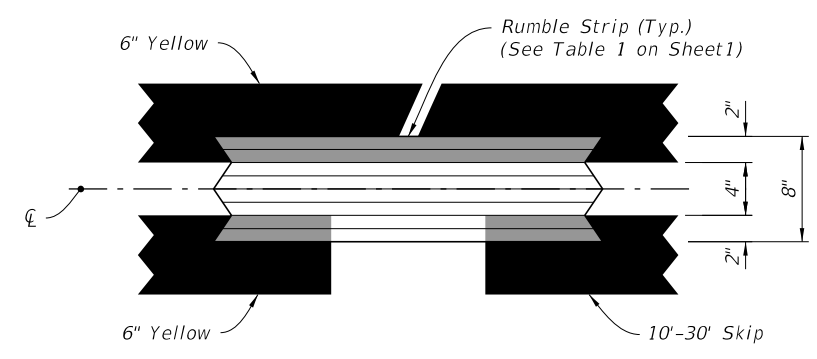

ONE-DIRECTION PASSING CENTERLINE

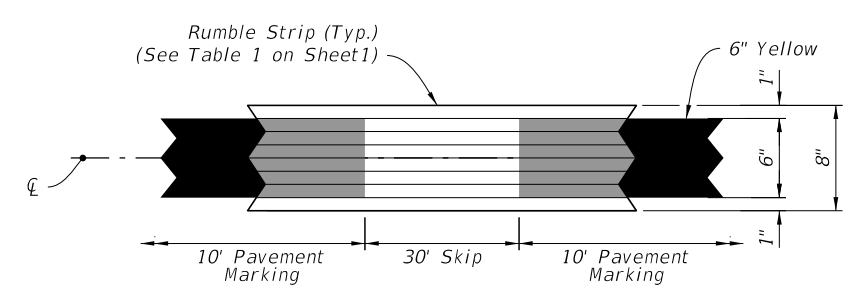

TWO-DIRECTION PASSING CENTERLINE

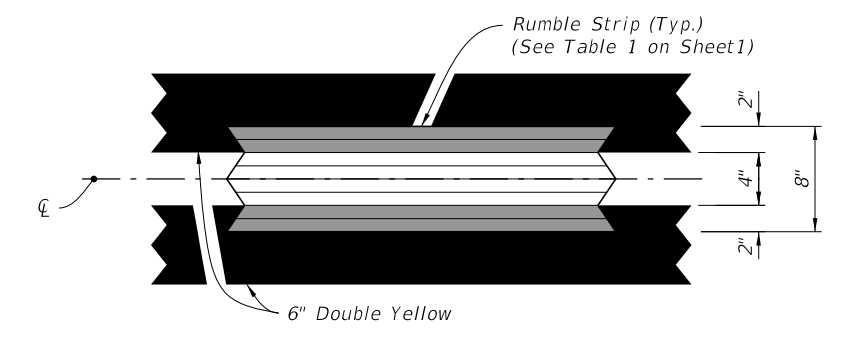

TWO-DIRECTION NO-PASSING CENTERLINE

CENTERLINE RUMBLE STRIP PLACEMENT
(Plan View)

12/22/2022 12:41:10 PM

NOTES

DESIGN CRITERIA:

- Design is based on the assumption that the material contained within the reinforced soil volume, methods of construction and quality of prefabricated materials are in accordance with Specification Section 548 and Chapter 3 of the FDOT Structures Design Guidelines.

SOIL PARAMETERS:

- See Wall Control Drawings for soil characteristics of foundation material to be used in the design of the wall system.
- The Contractor will provide soil design parameters for backfill material based on the actual soil characteristics utilized at the site.

MATERIALS:

- See Specification Section 548 for material requirements.

CONSTRUCTION:

- Walls will be constructed in accordance with Specification Section 548 and the Wall Company's instructions.
- For location and alignment of retaining walls, see Wall Control Drawings.
- If required, locate manholes and drop inlets as shown on wall elevations.
- Refer to Wall Control Drawings of individual walls for minimum reinforcement strip/mesh length, factored bearing resistance's, minimum wall embedment and anticipated long term and differential settlements.
- The Contractor is responsible for controlling water during storm events as needed during construction.
- It is the Contractor's responsibility to determine the location of any guardrail posts behind retaining wall panels. Prior to placement of the top layer of soil reinforcement, individual reinforcing strips/mesh may be skewed (15° maximum) to avoid the post locations if authorized by the Engineer. No cutting of soil reinforcement is allowed unless shown on Shop Drawings and approved by the Engineer. Any damage done to the soil reinforcement due to installation of the guardrail will be repaired by the Contractor at the Contractor's expense. Repair method will be approved by the Engineer.
- If existing or future structures, pipes, foundations or guardrail posts within the reinforced soil volume interfere with the normal placement of soil reinforcement and specific directions have not been provided on the plans, the Contractor will notify the Engineer to determine what course of action shall be taken.
- The Contractor is responsible for gradually displacing upper layer(s) of soil reinforcement downward (15° maximum from horizontal) to avoid cutting soil reinforcement and conflicts with paving and subgrade preparation. The Contractor's attention is directed especially to situations where roadway superelevation and/or soil mixing are anticipated.
- For concrete facing panel surface treatment, see Wall Control Drawings. Extend surface treatment a minimum of 6" below final ground line.
- Drive piles located within the soil volume prior to construction of the retaining wall, unless a method to protect the structure, acceptable to both the Engineer and Wall Company, is proposed and approved in writing. The portion of piles or drilled shafts extensions within the soil volume will be wrapped with polyethylene sheeting in accordance with Specification Section 459.
- A structural extension of the connection of the retaining wall panel to soil reinforcement will be used whenever necessary to avoid cutting or excessive skewing (greater than 15°) of the soil reinforcement around obstructions (i.e., piles, pipes, manholes, drop inlets, etc.).
- Steps in leveling pads will occur at MSE Wall panel interfaces. Panels will not cantilever more than 2" past the end of the upper tier leveling pad.
- The top of the leveling pad or footing will be 2'-0" minimum below final ground line.
- Top of leveling pad elevations shown in the Wall Control Drawings are maximum elevations. The constructed leveling pad elevations may be deeper based on the panel layout shown in the shop drawings.
- The height of panels in the bottom course of MSE Walls must not be less than half the height of a standard panel.
- Work this Index with Index 521-600 thru 521-650.

SHOP DRAWINGS:

See Specification Section 548 for shop drawing requirements.

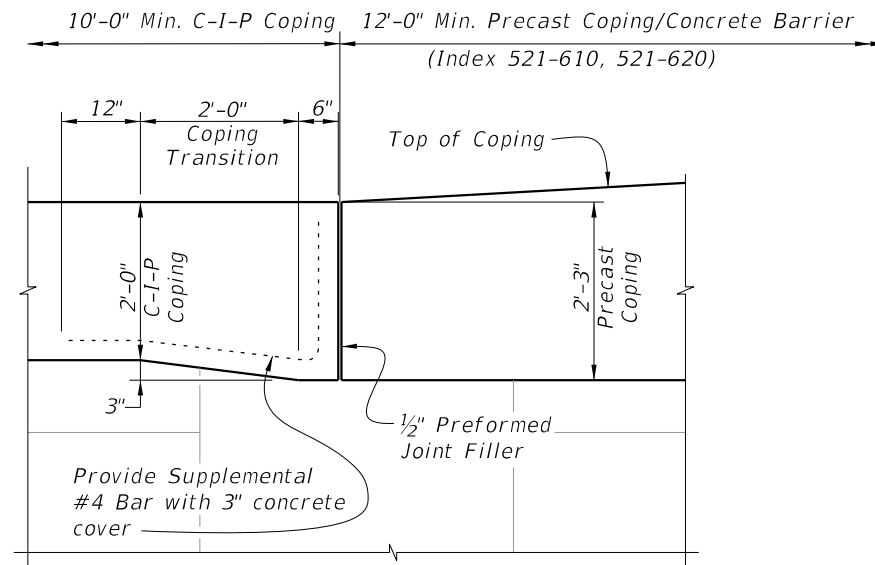

ELEVATION VIEW OF COPING HEIGHT TRANSITION

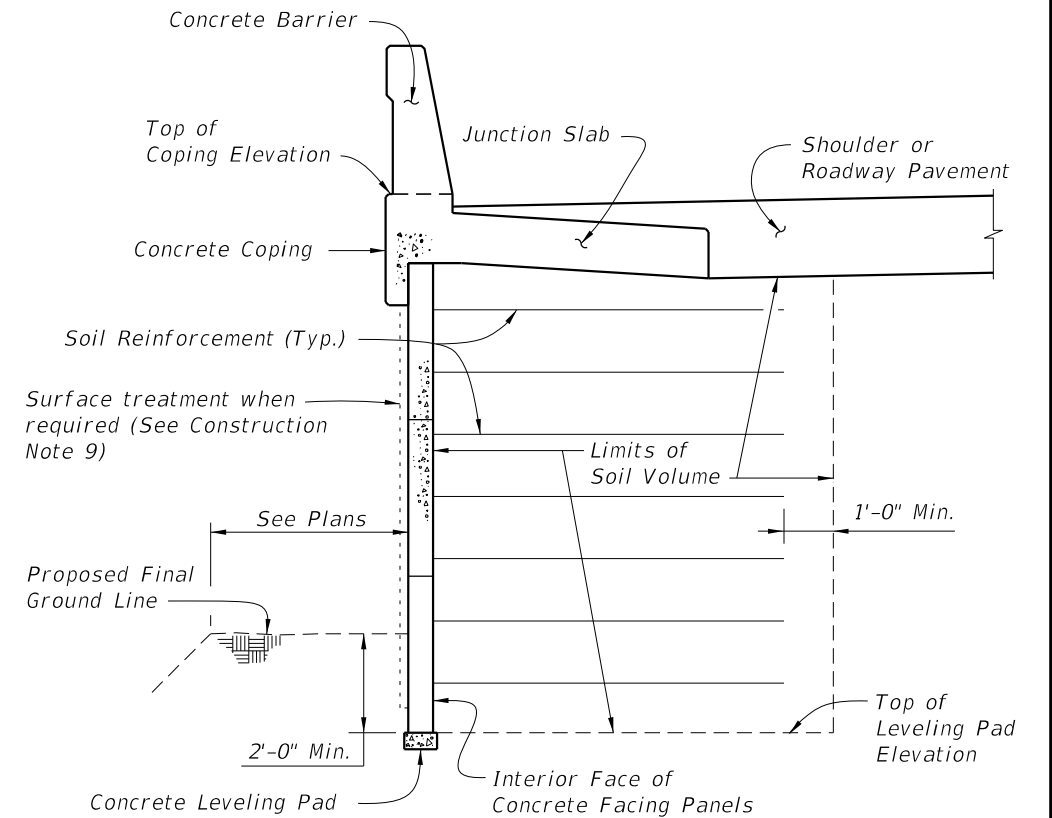

TYPICAL MSE RETAINING WALL SECTION WITH A CONCRETE BARRIER (Showing Limits of the Reinforced Soil Volume)

FDOT MSE RETAINING WALL CLASSIFICATION TABLE

Applicable FDOT Wall Type *	Durability Requirements (Carbon-Steel Reinforcing)			Durability Requirements (FRP Reinforcing)			Soil Reinforcement Type	Other Allowable FDOT Wall Types					
	Concrete Cover (in.)	Concrete Class for Panels	Pozzolan Additions? **	Concrete Cover (in.)	Concrete Class for Panels	Pozzolan Additions? **		2A	2B	2C	2D	2E	2F
Type 2A	2	II	No	1.5	II	No	Metal		✓	✓	✓	✓	✓
Type 2B	2	IV	No	1.5	IV	No	Metal			✓	✓	✓	✓
Type 2C	3	IV	No	1.5	IV	No	Metal				✓	✓	✓
Type 2D	3	IV	Yes	2	IV	No	Metal						✓
Type 2E	3	IV	No	2	IV	No	Plastic						✓
Type 2F	3	IV	Yes	2	IV	No	Plastic						

* See Data Table in Contract Plans.

** Highly Reactive Pozzolans.

GENERAL NOTES AND DETAILS

10/20/2022 8:54:30 AM

LAST REVISION 11/01/21	DESCRIPTION:		FY 2023-24 STANDARD PLANS	MSE RETAINING WALL SYSTEMS - PERMANENT	INDEX	SHEET
					548-020	1 of 1

NOTES

DESIGN CRITERIA:

1. Design is based on the assumption that the material contained within the reinforced soil volume, methods of construction and quality of prefabricated materials are in accordance with Specification Section 548 and FDOT Structures Design Guidelines Section 3.13.2.
2. It is the responsibility of the Engineer to determine that the factored bearing pressure shown for the wall does not exceed the factored bearing resistance of the foundation for that specific wall location.
3. The Wall Company is responsible for internal stability of the wall. External stability design, including foundation and slope stability, is the responsibility of the Engineer.
4. If present, consider in design and analysis and locate manholes and drop inlets as shown on wall elevations.

SOIL PARAMETERS:

1. See wall control drawings for soil characteristics of foundation material to be used in the design of the wall system. The Contractor must provide soil design parameters for backfill material based on the actual soil characteristics utilized at the site. Provide the values of unit weight, cohesion and internal friction angle in the Shop Drawings.

MATERIALS:

1. Provide soil reinforcement in accordance with Specification Section 548.
2. For additional material notes, see Wall Company General Notes.

CONSTRUCTION:

1. Walls must be constructed in accordance with Specification Section 548 and the Wall Company's instructions.
2. For location and alignment of retaining walls, see Wall Control Drawings.
3. Refer to Plan and Elevation sheets of individual walls for minimum reinforcement strip/mesh length, factored bearing resistance's, minimum wall embedment and anticipated long term and differential settlements.
4. If existing or future structures, pipes, foundations or guardrail posts within the reinforced soil volume interfere with the normal placement of soil reinforcement and specific directions have not been provided on the plans, the Contractor must notify the Engineer to determine what course of action should be taken.
5. The Contractor is responsible for gradually deflecting upper layer(s) of soil reinforcement downward (15° maximum from horizontal) to avoid cutting soil reinforcement and conflicts with paving and subgrade preparation. The Contractor's attention is directed especially to situations where roadway superelevation and/or soil mixing are anticipated.

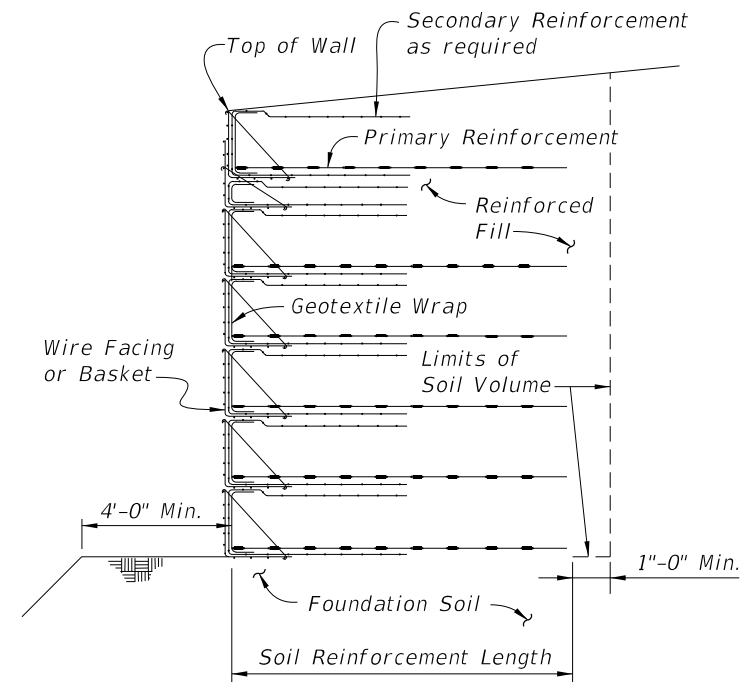

**TYPICAL RETAINING WALL SECTION
(Showing Limits of the Reinforced Soil Volume)**

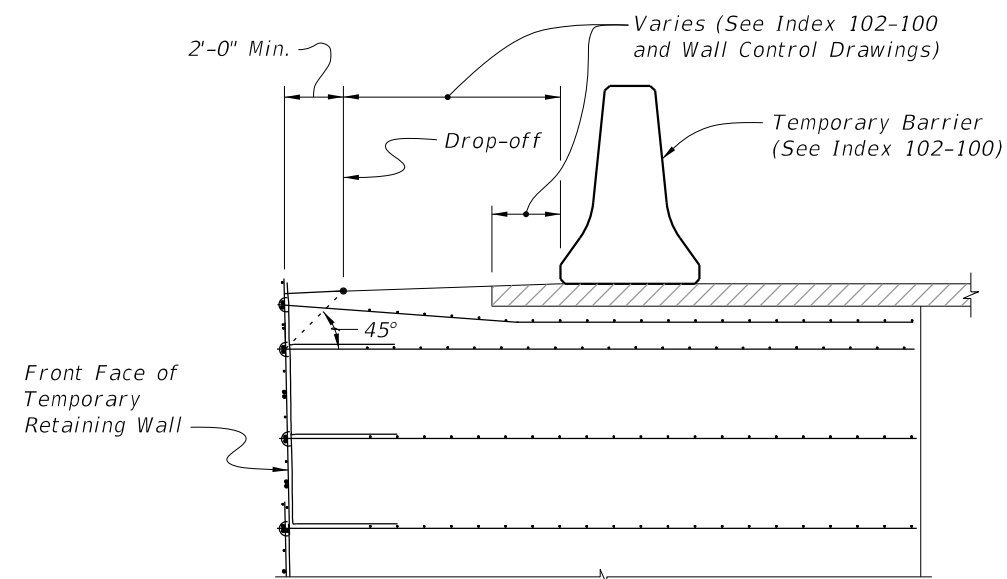

**TEMPORARY TRAFFIC RAILING
PLACEMENT DETAIL**

GENERAL NOTES AND DETAILS

10/20/2022 8:54:31 AM

LAST REVISION 11/01/17	REVISION	DESCRIPTION:		FY 2023-24 STANDARD PLANS	MSE RETAINING WALL SYSTEMS - TEMPORARY	INDEX 548-030	SHEET 1 of 1
---------------------------	----------	--------------	---	------------------------------	--	------------------	-----------------

GENERAL NOTES:

1. This fence to be provided generally in rural areas. For supplemental information see Specifications 550.
2. Fabric shall be woven wire, either galvanized steel, meeting the requirements of ASTM A116, No. 9 Grade 60, Design Number 1047-6-9, with Class 3 zinc coating; No. 12 1/2 Grade 175, Design Number 1047-6-12 1/2, with a 10 1/2 gage top and bottom wire and with Class 3 zinc coating; or aluminum coated steel, meeting the requirements of ASTM A584, No. 9 Farm, Design Number 1047-6-9, with a minimum coating weight of 0.40 oz./ft.². For additional information see payment note below.
3. Fence shall be installed with wire side to private property except on horizontal curves greater than 3° the fence shall be installed so as to pull against all posts.
4. Posts may be either timber, steel, recycled plastic or concrete. Unless a specific post material is called for in the plans, the Contractor may elect to use either a single material or a combination of timber, steel, recycled plastic or concrete materials, but must comply with the electrical grounding requirements in Specification 550. Line posts of one material may be used with corner, pull and end post assemblies of a different material. Line posts of only one optional material and pull post assemblies of only one optional material will be permitted between corner and end post assemblies. Within individual corner and end post assemblies only one optional material will be permitted.
5. Timber posts shall meet the material requirements of Specification 954. Timber line posts are to be minimum 4" diameter. Timber corner, pull, approach and end posts are to be a minimum 5" diameter. Timber braces are to be minimum 4" diameter.
 - (A) Staples for line posts to be 1 1/4" minimum length; for approach, corner and pull posts 1 1/2" minimum length. At approach, corner and pull posts, staple every line wire in top half and alternate line wires in bottom half. Staples shall be driven diagonally across the line wire with the points in separate grains.
 - (B) Connections between timber posts and braces to be provided by dowels as shown in fastener details.
 - (C) Wire to be wrapped and tied, as shown in the splice details, at the following locations:
 - (a) All end posts, (b) Corner post, including the assemblies at vertical breaks of 15° or more and
 - (c) Pull posts where the wire is not spliced and pulled through the assembly; see General Note 18.
6. Steel posts and braces shall be standard steel posts, galvanized at the rate of 2 oz./ft.², together with necessary hardware and wire clamps and meeting the following requirements:
 - (A) Line posts: 8' long; 1.33 lbs./ft.; hot rolled studded; anchor plate attached, ASTM A702 (18 in.²).
 - (B) Approach posts: 2 1/2"x2 1/2"x1/4" angles, 8' long; fabricated for attaching brace; with necessary hardware, clamps, etc.
 - (C) Pull, end and corner posts: 2 1/2"x2 1/2"x1/4" angles, 8' long; fabricated for attaching brace; with necessary hardware, clamps, etc.
 - (D) Braces: 2"x2"x1/4" angles with necessary hardware and fabricated for attaching to post.
 - (E) The pull, corner, approach and end posts are to be set in concrete as per detail. (Also see General Note 15)
7. Recycled plastic posts shall meet the following material requirements: Line posts shall have a minimum section of 4" round or 4" square. Plastic posts shall not be used as corner, pull, end or approach posts unless such use is specifically detailed in the plans. The straightness of the post shall comply with Specification 954 for timber post. The flexural strength shall meet the requirements of the latest edition of the Southern Pine Inspection Bureau's Standard Grading Rules for Southern Pine Lumber for No. 2SR Stress Rated Grade Timber. Plastic posts can be set by either digging and tamped backfill or by driving into full depth preformed holes 1/4" to 1/2" smaller than cross section of post. Staples for fabric and barbed wire connection to plastic line posts shall be the same size, count and location as that for timber posts.
8. The Contractor, at his option, may use any suitable precast or prestressed concrete posts; however, approval by the Engineer, of posts not shown on this index, will be required prior to construction of the fence. Precast posts shall be Class II concrete. Prestressed posts shall be Class III concrete. Lengths of concrete post to be as indicated for timber posts.
9. Aluminum post, braces and accessory framing hardware shall not be used unless the plans specifically detail their application or the Engineer approves their incorporation in fence construction or repair. Aluminum framed gates are permitted as described in General Note 19.
10. The woven wire shall be attached to steel and concrete posts by a minimum of five tie wires. The single wire ties shall be applied to the top, bottom and three intermittent line wires. The ends of each tie wire shall have a minimum of two tight turns around the line wire. Tie wires shall be steel wire not less than 0.120" diameter, zinc coating Class 3, soft temper, in accordance with ASTM A641.
11. Steel Barbed Wire can be either of the following types:
 - Type I: This type shall conform to the requirements of ASTM A121, with two strands of 12 1/2 gage wire; four-point barbs, wire size 14 gage, twisted around both line wires; and, Class 3 coating, Design No. 12-4-5-14R.
 - Type IIA: This type same as Type I except the two strand wires are twisted in alternating directions between consecutive barbs.
 - Type IIB: This type shall conform to the requirements of ASTM A121 with two strands of 15 1/2 gage high tensile wire; four-point barbs, wire size 16 1/2 gage twisted around both line wires; and Class 3 coating, Design No. 15-4-5-16R.
 Aluminum Barbed Wire shall be fabricated of two strands of 0.110-inch wire with 0.08-inch diameter four-point barbs spaced at approximately 5 1/2", and at a maximum spacing of 6". The wire for the strands and for the barbs shall be of ASTM B211M Alloy 5052-H38 or equal.
12. The woven wire shall be stretched only until one-half the tension curl has been pulled out of the line wires.
13. Posts to be set by driving or digging. If by digging, the posts shall be set at the center of the hole and the soil tamped securely on all sides.
14. Longer posts than those indicated above may be required by the plans or for deeper installations.
15. Concrete bases for angular steel posts (pull, corner, end and approach) shall be Class NS in accordance with Specification 347. Materials for Class NS concrete may be proportioned by volume and/or by weight.
16. Pull post assemblies shall be installed at approximately 330° centers except that this maximum interval may be reduced by the Engineer on curves where the radius is less than 3°.
17. Corner post assemblies are to be installed at all horizontal and vertical breaks in fence of 15° or more.
18. A maximum length of 1320' of wire may be installed as a unit. For pulls through a pull post assembly the fabric shall be spliced by crimping sleeves only. Pulls through a corner post assembly will not be permitted.
19. Unless otherwise called for in the plans gates shall be commercially available metal swing gates assembled and installed in accordance with the manufacturer's specifications as approved by the Engineer. Chain link swing gates in accordance with Index 550-002 may be substituted for metal swing gates as approved by the Engineer. Gate size is full opening width whether single leaf or double leaves. Payment for gates shall include the gate, single or double, all necessary hardware for installation and any additional length and/or size for posts at the opening. Gates shall be paid for under the contract unit price for Fence Gates, EA.
20. For construction purposes, assemblies are defined as follows: End post assemblies shall consist of: one end post, one approach post, two braces, four diagonal tension wires and all necessary fittings and hardware. Pull post assemblies shall consist of: one pull post, two braces, four diagonal tension wires and necessary fittings and hardware. Corner post assemblies shall consist of: one corner post, two approach posts, four braces, eight diagonal tension wires and all necessary fittings and hardware.
21. All posts, braces, tension wires, fabric, tie wires, Class NS concrete, and all miscellaneous fittings and hardware to be included in the cost for Fencing, LF. Fencing shall be inclusive of the lengths of pull, end and corner post assemblies, but exclusive of gate widths.

10/20/2022 8:54:32 AM

LAST REVISION 11/01/21	REVISION	DESCRIPTION:	 FY 2023-24 STANDARD PLANS	FENCE TYPE A	INDEX 550-001	SHEET 1 of 3
---------------------------	----------	--------------	---	--------------	------------------	-----------------

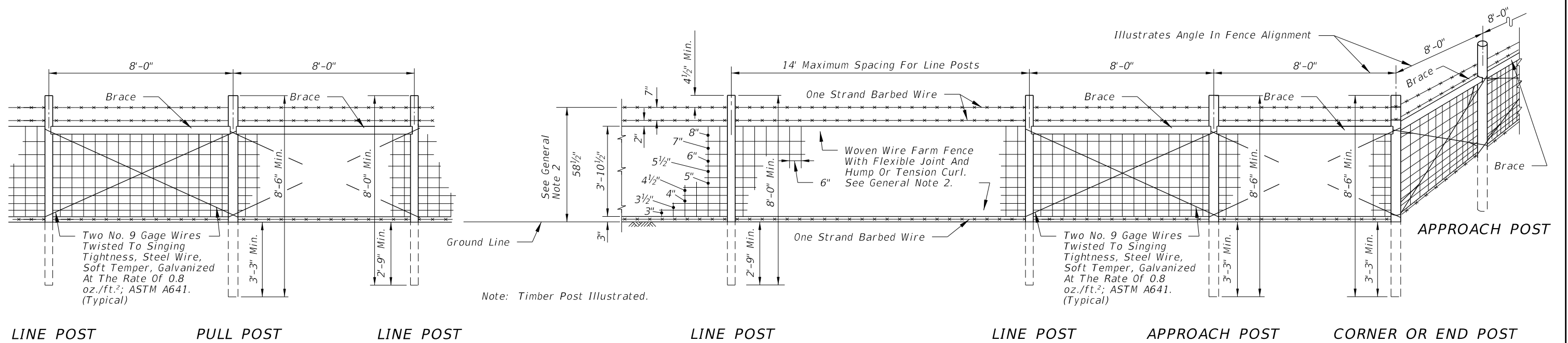

LINE POST PULL POST LINE POST LINE POST LINE POST APPROACH POST CORNER OR END POST

DESIGN NOTE:
 This index details fencing that is constructed with farm fabric 46½" (47" nominal) in height and with specific ground clearance and specific barbed wire spacings. For fencing of different height or installation details, the fence shall be fully detailed in the Contract plans.

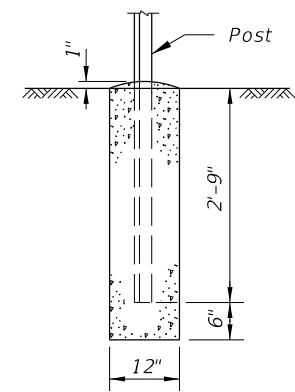

(Pull, Corner, End And Approach Posts)
CONCRETE BASE FOR ANGULAR STEEL POST

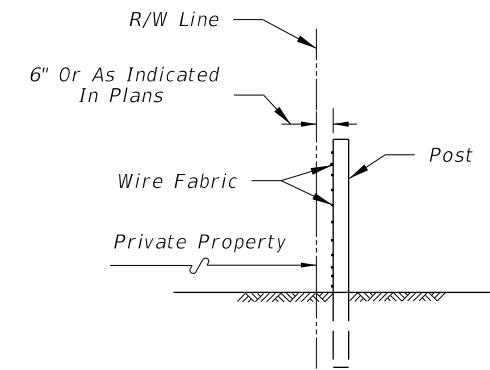

FENCE POSITION AT LOCATIONS WITHOUT FRONTAGE ROADS
 (REFER TO DETAIL PLANS FOR FENCE POSITION AT LOCATIONS WITH FRONTAGE ROADS)

10/20/2022 8:54:33 AM

LAST REVISION 11/01/17	REVISION	DESCRIPTION:	 FY 2023-24 STANDARD PLANS	FENCE TYPE A	INDEX 550-001	SHEET 2 of 3
---------------------------	----------	--------------	--	---------------------	------------------	-----------------

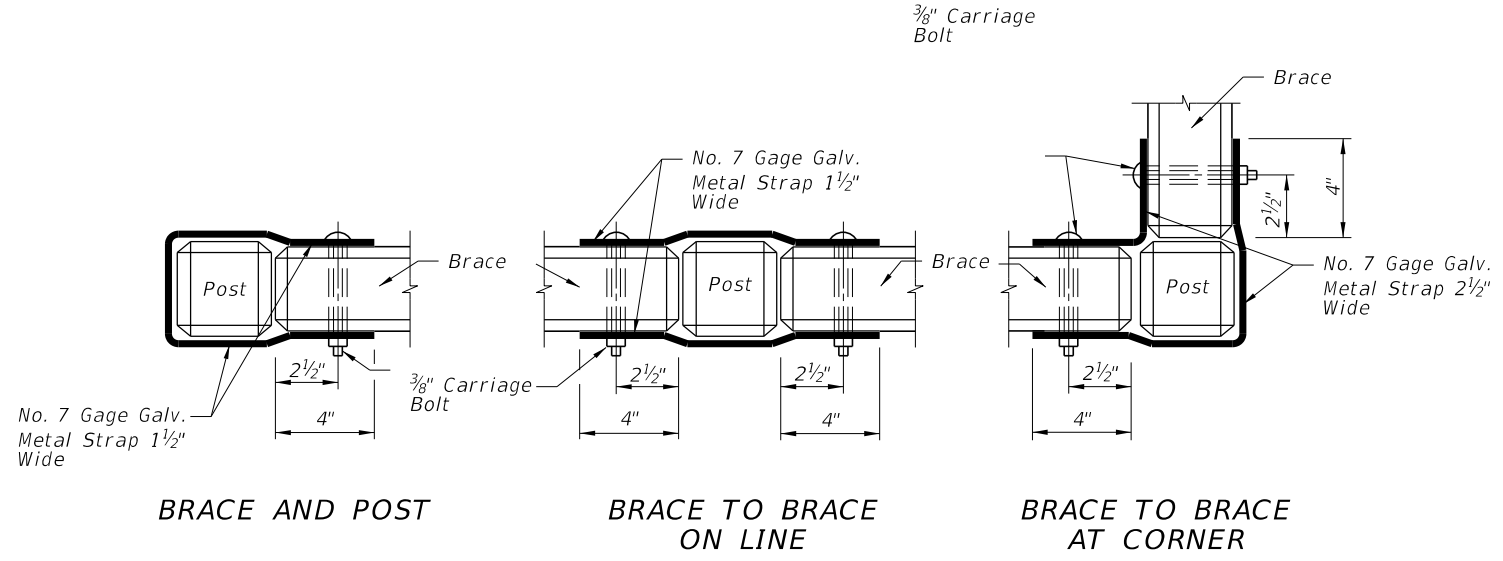

BRACE AND POST

BRACE TO BRACE ON LINE

BRACE TO BRACE AT CORNER

FASTENER FOR CONCRETE POST AND BRACES

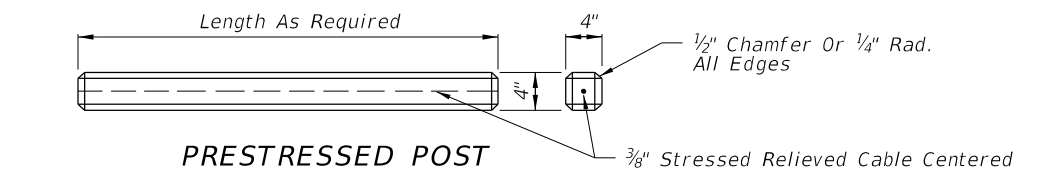

PRESTRESSED POST

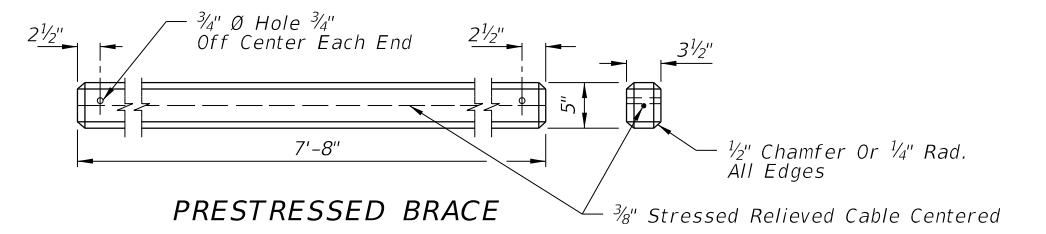

PRESTRESSED BRACE

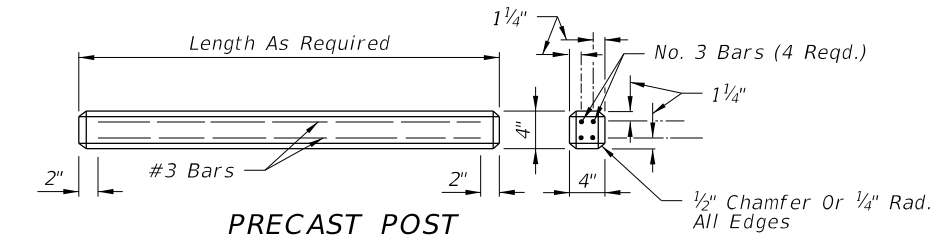

PRECAST POST

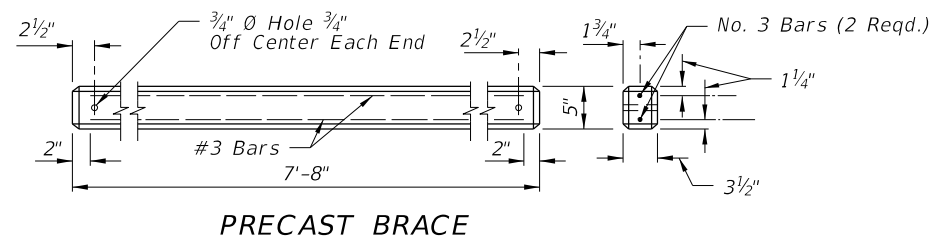

PRECAST BRACE

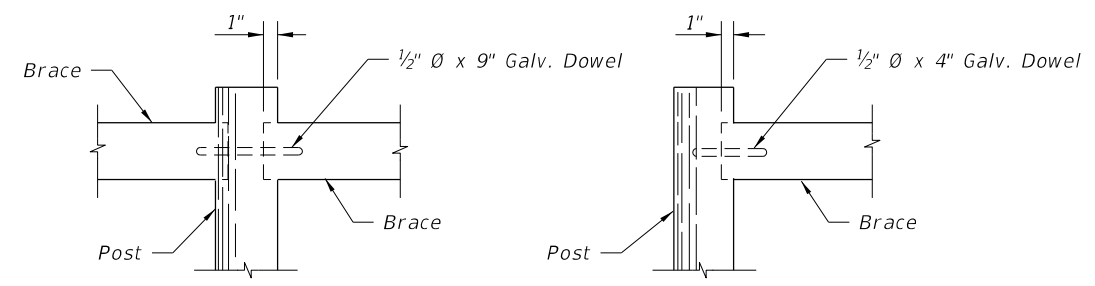

FASTENER FOR TIMBER POST AND BRACE

ALTERNATE CONCRETE POSTS AND BRACES

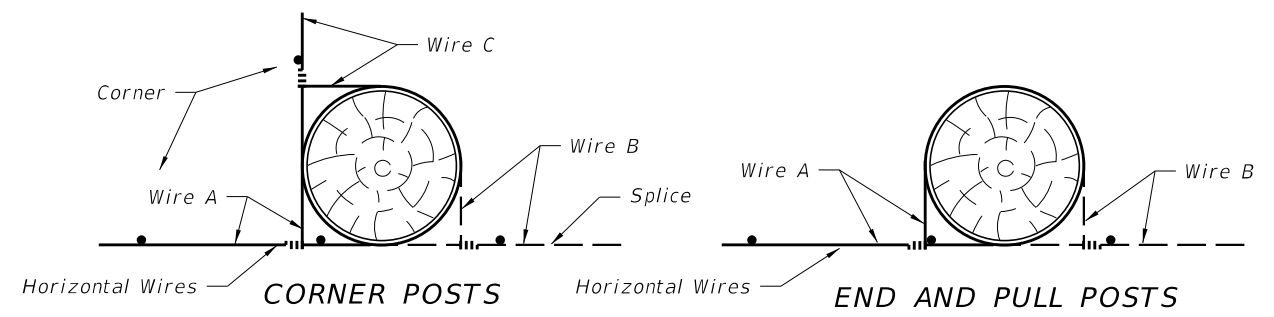

CORNER POSTS

END AND PULL POSTS

Each horizontal wire to be wrapped around corner, end and pull posts and tied to same wire. See General Notes 5 and 17. Timber post illustrated. These methods also apply to steel and concrete post illustrations.

SPLICES

10/20/2022 8:54:34 AM

LAST REVISION 11/01/17	REVISION	DESCRIPTION:		FY 2023-24 STANDARD PLANS	FENCE TYPE A	INDEX 550-001	SHEET 3 of 3
---------------------------	----------	--------------	--	------------------------------	--------------	------------------	-----------------

GENERAL NOTES:

1. This fence to be used generally in urban areas.
2. For supplemental information refer to Specification 550.
3. Chain link fabric, post, truss rods, tension wires, tie wires, stretcher bars, gates and all miscellaneous fittings and hardware shall meet the requirements of AASHTO and ASTM signify current reference.
4. Fence Component Options:
 - A. Line post options:
 - (1) Galvanized steel pipe, Schedule 40- 1 1/2" nominal dia. zinc galvanized at the rate of 1.8 oz./ft².: ASTM A53 Table 2 (Grade A or B), ASTM F1083, and AASHTO M111.
 - (2) Aluminum coated steel pipe: ASTM A53, Table 2 (Grade A or B): Schedule 40- 1 1/2" nominal dia., 1.90" OD; coated at the rate 0.40 oz./ft.: AASHTO M111.
 - (3) Aluminum alloy pipe- 2" nominal dia.: ASTM B241 or B221, Alloy 6063, T6.
 - (4) Steel H-Beam- 1 7/8" x 1 5/8": Zinc Galv. 1.8 oz./ft.: AASHTO M111 and Detail.
 - (5) Aluminum alloy H-Beam- 1 7/8" x 1 5/8" Detail.
 - (6) Steel C- 1 7/8" x 1 5/8": Galv.: 1.8 oz./ft. zinc: AASHTO M111; OR , 0.9 oz./ft². zinc-5% aluminum-mischmetal: ASTM F1043 and Detail.
 - (7) Resistance welded steel pipe; 50,000 psi min. yield strength ASTM A569/A569M, A653/A653M or undepleted stock of discontinued A446/A446M base materials; ASTM F669 Group IV (Alternative Design); fence industry 2" OD, 1 1/2" NPS, 1,900" dec. equiv., 0.120" min. wall thick. and min. wt. 2.28 lb./ft.; with ASTM F1043 metric equivalent internal coating Types A, B, C or D and external coating Types A, B, or C; the chromate conversion coating of external Type B shall have a thickness of 15µg/in². min. and the polymer film topcoat shall have a thickness of 0.0003" min.; internal and external coatings are not restricted to the combinations of Table 2, ASTM F1043.
 - B. Corner, end, and pull post options:
 - (1) Galvanized steel pipe, Schedule 40- 2" nominal dia. zinc galvanized at the rate of 1.8 oz./ft².: ASTM A53 Table X 2, ASTM F1083, and AASHTO M111.
 - (2) Aluminum coated steel pipe: ASTM A53 steel, X 2 Tables: Schedule 40; 2" nominal dia., 2.375" OD; coated at the rate 0.40 oz./ft.: AASHTO M111.
 - (3) Aluminum alloy pipe- 2 1/2" nominal dia.: ASTM B241 or B221, Alloy 6063, T6.
 - (4) Resistance welded steel pipe; 50,000 psi min. yield strength ASTM A569/A569M, A653/A653M or undepleted stock of discontinued A446/A446M base materials; ASTM F669 Group IV (Alternative Design); fence industry 2 1/2" OD, 2" NPS, 2.375" dec. equiv., 0.130" min. wall thick. and min. wt. 3.117 lb./ft.; with ASTM F1043 metric equivalent internal coating Types A, B, C or D and external coating Types A, B, or C; the chromate conversion coating of external Type B shall have a thickness of 15µg/in². min. and the polymer film topcoat shall have a thickness of 0.0003" min.; internal and external coatings are not restricted to the combinations of Table 2, ASTM F1043.
 - C. Rail options:
 - (1) Galvanized steel pipe, Schedule 40- 1 1/4" nominal dia. zinc galvanized at the rate of 1.8 oz./ft².: ASTM A53 Table X 2, ASTM F1083, and AASHTO M111.
 - (2) Aluminum coated steel pipe; ASTM A53 steel, X 2 Tables: Schedule 40; 1 1/4" nominal dia., 1.660" OD; coated at the rate 0.40 oz./ft.: AASHTO M111.
 - (3) Aluminum alloy pipe- 1 1/4" nominal dia.: ASTM B241 or B221, Alloy 6063, T6.
 - (4) Resistance welded steel pipe; 50,000 psi min. yield strength ASTM A569/A569M, A653/A653M or undepleted stock of discontinued A446/A446M base materials; ASTM F669 Group IV (Alternative Design); fence industry 1 5/8" OD, 1 1/4" NPS, 1.660" dec. equiv., 0.111" min. wall thick. and min. wt. 1.836 lb./ft.; with ASTM F1043 metric equivalent internal coating Types A, B, C or D and external coating Types A, B, or C; the chromate conversion coating of external Type B shall have a thickness of 15µg/in². min. and the polymer film topcoat shall have a thickness of 0.0003" min.; internal and external coatings are not restricted to the combinations of Table 2, ASTM F1043.
 - D. Chain link fabric options (2" mesh with twisted and barbed selvage top and bottom for all options except as described in Note 10):
 - (1) AASHTO M181 Type I - Zinc Coated Steel, No. 9 gage (coated wire diameter), coated at the rate of 1.8 oz./ft². (M181 Class D 2.0 oz./ft². modified to 1.8 oz./ft²).
 - (2) AASHTO M181 Type II - Aluminum Coated Steel, No. 9 gage (coated wire diameter), coated at the rate of 0.40 oz./ft².
 - (3) AASHTO M181 Type IV - Polyvinyl Chloride (PVC) Coated Steel, No. 9 gage (coated core wire diameter), core wire-zinc coated steel. PVC coating: M181 Class A (either extruded or extruded and bonded) or Class B (bonded). See table right. Unless the plans call for M181 standard colors medium green, dark green or black the coating color shall be soft gray matching that of No. 36622 of Federal Standard 595a.
 - E. Tension wire options:
 - (1) Steel wire No. 7 gage zinc galvanized at the rate of 1.2 oz./ft².: AASHTO M181.
 - (2) Aluminum alloy wire with a diameter of 0.1875" or larger conforming to the requirements of ASTM B211, Alloy 5056 Temper H38, or, Alclad Alloy 5056 Temper H192.
 - (3) Aluminum coated steel wire No.7 gage coated at the rate of 0.040 oz./ft².: AASHTO M181.
 - F. Tie wire and hog ring options:
 - (1) Steel wire No.9 gage zinc galvanized at the rate of 1.2 oz./ft².
 - (2) Aluminum alloy wire with a diameter of 0.1443" or larger conforming to the requirements of ASTM B211, Alloy 5056 Temper H38, or, Alclad Alloy 5056 Temper H192.
 - (3) Aluminum coated steel wire No. 7 gage coated at the rate of 0.040 oz./ft².

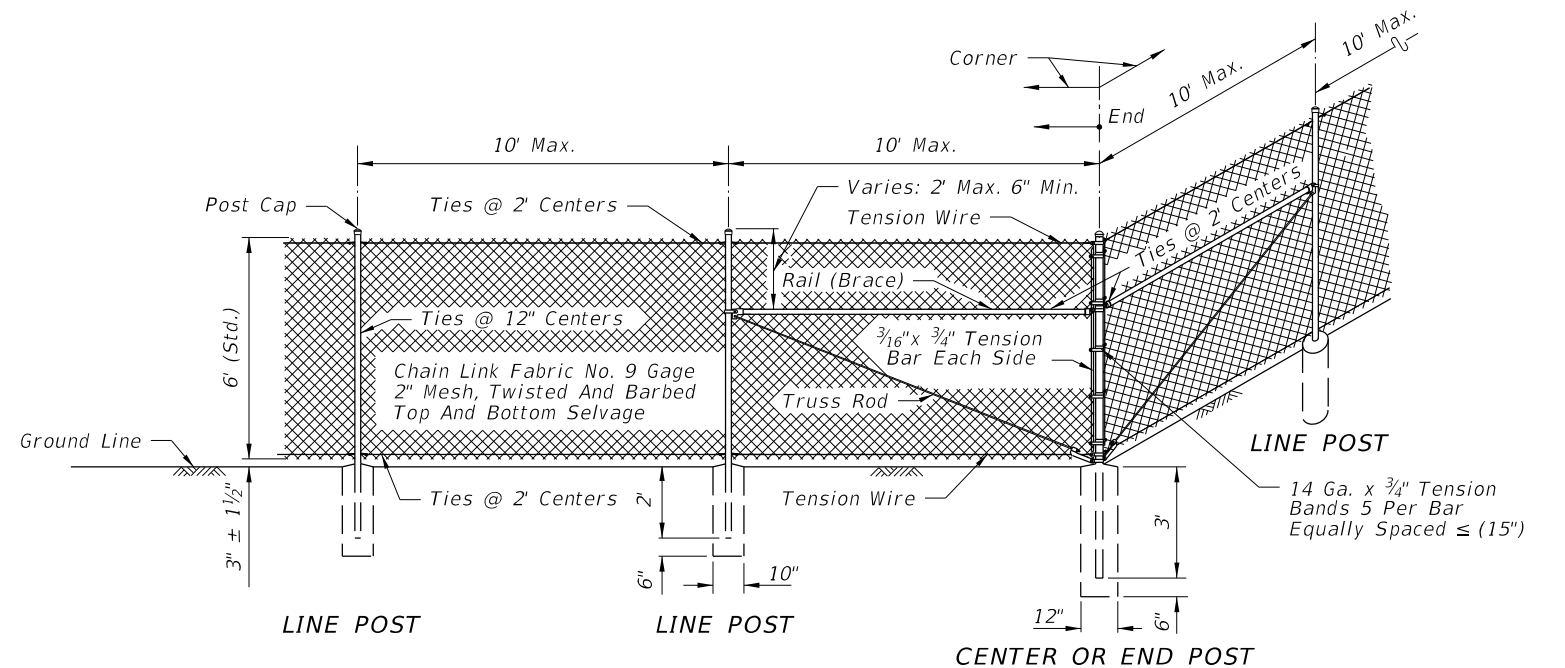

CORNER OR END POST

NOTE: Tubular Post Illustrated

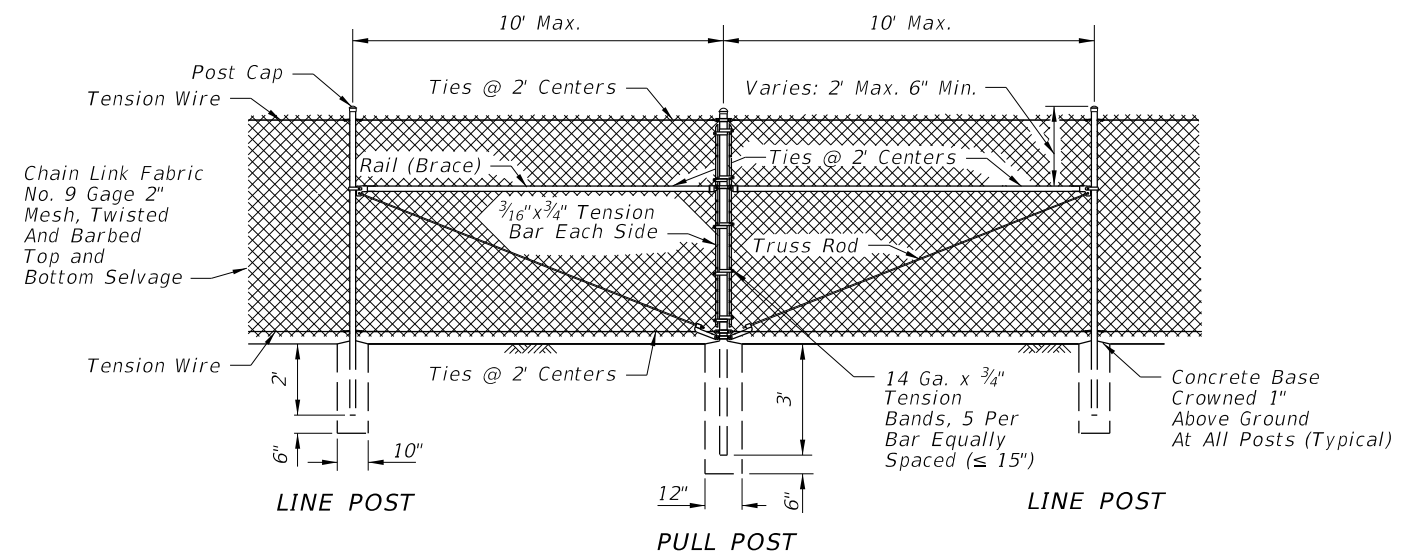

PULL POST

NOTE: Tubular Post Illustrated

10/20/2022 8:54:35 AM

LAST REVISION 11/01/17	REVISION	DESCRIPTION:	FY 2023-24 STANDARD PLANS	FENCE TYPE B	INDEX 550-002	SHEET 1 of 3
---------------------------	----------	--------------	--------------------------------------	---------------------	------------------	-----------------

GENERAL NOTES CONTINUED

5. Unless a specific material is called for in the plans the Contractor may elect to use either a single type of material or a combination of material types from the component options listed in note 4. Combinations of optional materials are restricted as follows:
 - (a) Only one fabric optional material will be permitted between corner and/or end post assemblies.
 - (b) Only one line post optional material will be permitted between corner and/or end post assemblies.
 - (c) Pull post assemblies shall be optional materials identical to either the line post optional material or the corner and end post assembly optional material; but, pull post assemblies shall be the same optional material between any set of corner and/or end post assemblies.
6. Concrete for bases shall be Class NS concrete as specified in Specification 347 or a packaged, dry material meeting the requirements of a concrete under ASTM C-387. Materials for Class NS concrete may be proportioned by volume and/or by weight.
7. Line post shall be 8'-6" long (Standard). Line post are to be set in concrete as described above or by the following methods:
 - (a) In accordance with special details and/or as specifically described in the Contract Plans and Specifications.
 - (b) In accordance with ASTM F567 Subsections 5.4 through 5.10 as approved by the Engineer. Line post installed in accordance with Section 5.8 shall be 9'-6" long.
 - (c) Post mounted on concrete structure or solid rock shall be mounted in accordance with the base plate detail "Fence Mounting On Concrete Endwalls And Retaining Wall", Sheet 3; or, by embedment in accordance with ASTM F567 Subsection 5.5.

End, pull and corner post assemblies shall be in concrete as detailed above for all soil conditions other than solid rock. Post within assemblies that are located on concrete structures or solid rock shall be set by base plate or by embedment as prescribed under (b) above for line post.

Line and assembly posts for 6' fence which must be lengthened due to a variation in the normal ground clearance, shall be set an additional 3" in depth for each 1' of additional ground clearance.
8. Pull post shall be used at breaks in vertical grades of 15° or more, or at approximately 350' centers except that this maximum interval may be reduced by the Engineer on curves where the curve is greater than 3°.
9. Corner post are to be installed at all horizontal breaks in fence at 15° or more and as required at vertical breaks over 15° as determined by the Engineer.
10. When fence has an installed top of fabric height less than 6' knuckled top and bottom selvages shall be used unless the plans specifically identify locations for twisted selvage fabrics.
11. Unless sliding gates or special gates are called for in the plans, all gates shall be chain link swing gates meeting the material requirements described and as approved by the Engineer. Payment shall include the gates, single or double, all necessary hardware for installation and any additional length and/or size for posts at the opening. Gates shall be paid for under the contract unit price for Fence Gates, EA.
12. For construction purposes corner post assemblies shall consist of one corner post, two braces, two truss rods, and all necessary fittings and hardware as detailed. End post assemblies shall consist of one end post, one brace, one truss rod and all necessary fittings and hardware as detailed.
13. In areas where there are physical constraints outside the right-of-way which restricts the fence construction, the fabric may be installed on the inside of the posts..

TYPE IV VINYL COATED FABRIC								
AASHTO M181 Table 4 Redefined As Follows								
Specified Diameter Of Metallic Coated Core Wire		Minimum Weight Of Zinc Coating		PVC Thickness Range				
				M181 Class A (Extruded Or Extruded And Bonded Coating)		M181 Class B (Bonded Coating)		
in.	mm	gage	oz./ft ² .	g/m ²	in.	mm	in.	mm
0.148	3.77	9	0.30	92	0.015 to 0.025	0.38 to 0.64	0.006 to 0.010	0.15 to 0.25

DESIGN NOTE

This index details fencing that is constructed with chain link fabric 6' (nominal) in height and with specific ground clearance. For fencing of different height or installation details, the fence shall be fully detailed in the Contract plans.

10/20/2022 8:54:36 AM

LAST REVISION 11/01/17	REVISION	DESCRIPTION:	 FY 2023-24 STANDARD PLANS	FENCE TYPE B	INDEX 550-002	SHEET 2 of 3
---------------------------	----------	--------------	---	---------------------	-------------------------	------------------------

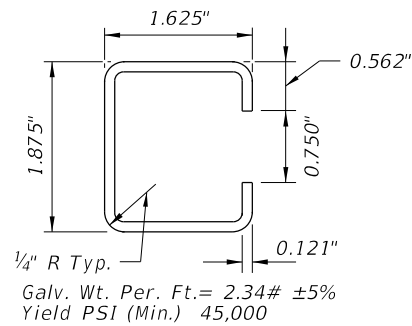

STANDARD WALL

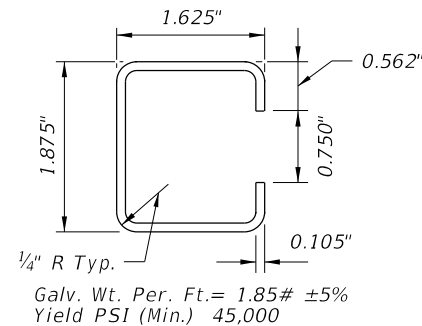

THINWALL

OPTIONAL "C" LINE POST

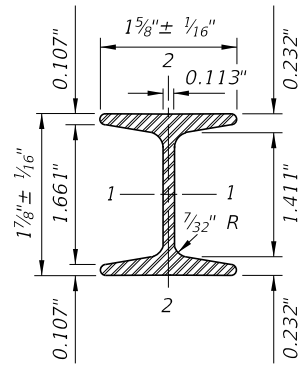

	STEEL		ALUMINUM	
	1-1	2-2	1-1	2-2
Area (Sq. In.)	724		724	
Weight (Lb./Ft.)	2.72 ± 5% (Galv.)		0.91 ± 5%	
Surface Area (SF/Ft.)	0.776		0.776	
Tensile Strength (psi Min.)	80,000		30,000	
Yielding Point (psi Min.)	48,000		25,000	
Moment of Inertia	0.428	0.101	0.428	0.101
Section Modulus	0.456	0.124	0.456	0.124
Rad. of Gyration	0.779	0.373	0.779	0.373

OPTIONAL 1 7/8" x 1 5/8" H-BEAM LINE POST

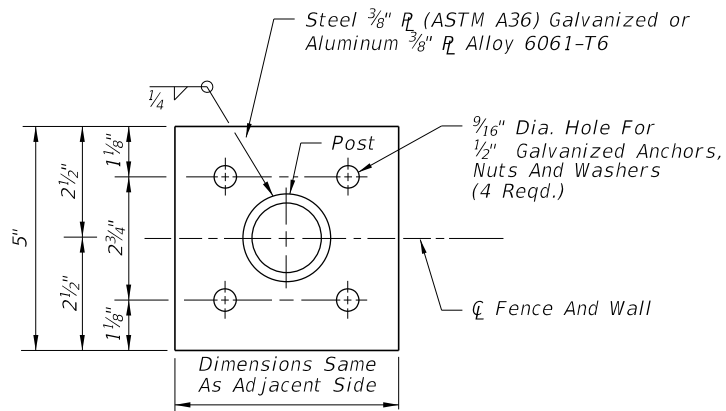

**TOP VIEW
FOUR ANCHOR PLATE OPTION**

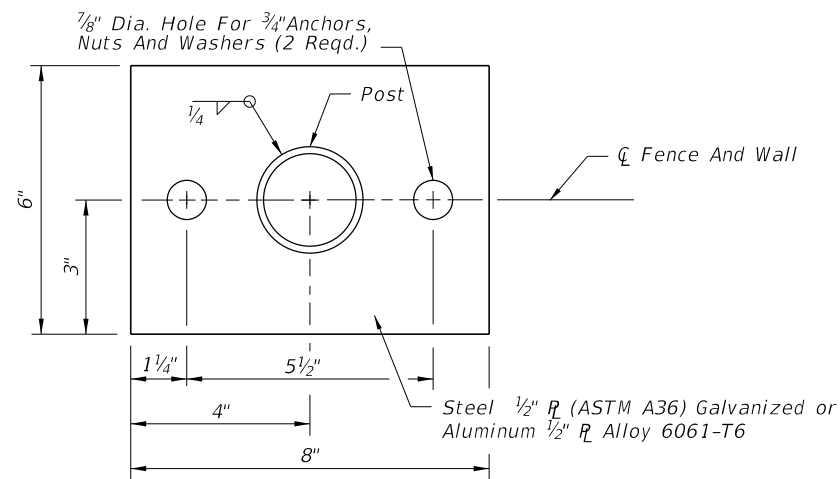

**TOP VIEW
TWO ANCHOR PLATE OPTION**

FENCE MOUNTING ON CONCRETE ENDWALL AND RETAINING WALLS

FENCE POSITION AT LOCATIONS WITHOUT FRONTAGE ROADS

(REFER TO DETAIL PLANS FOR FENCE POSITION AT LOCATIONS WITH FRONTAGE ROADS)

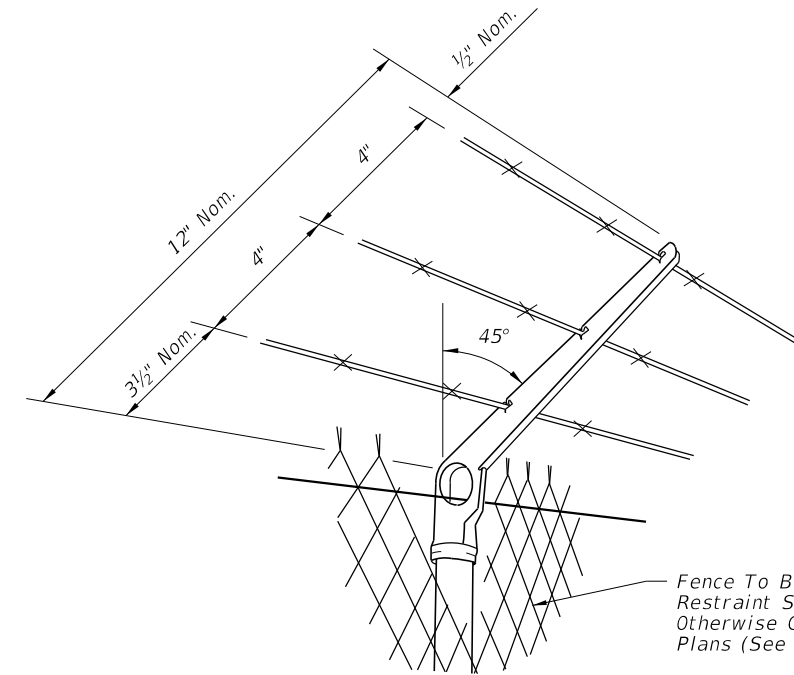
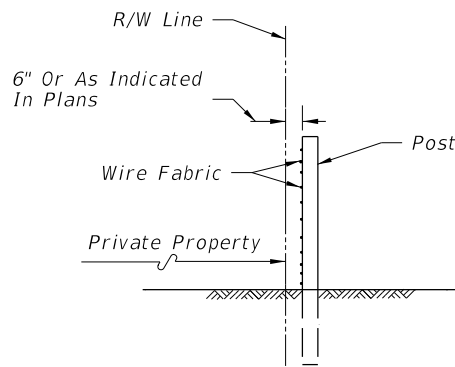

NOTES

- Attachments to be used only when called for in the plans. Attachments to extend in direction of restraint. Unless otherwise called for in plans, direction of restraint will be as follows:
- Outward on limited access right of way line.
 - Outward on controlled access right of way line.
 - Outward from utilities and hazardous facilities located within highway right of way.
 - Outward from lateral ditches, outfalls, retention basins, canals, borrow areas and similar support facilities.
 - Inward on pedestrian ways.
- The cap-arm shall be designed to provide a drive fit over the top of posts and to exclude moisture in posts with tubular sections.

BARB WIRE ATTACHMENT

BASE PLATE AND ANCHOR NOTES:

- Base plate identical for line, pull, end and corner posts and shall be considered an integral part of the respective posts for basis of payment.
- Post to be plumbed by grout shim under base plate.
- Anchors (Galvanized Steel):
12" Cast In Place, 10 1/2" Embedment:
Headed Bolts, U-Bolts or Cluster Plates.
8" Adhesive Anchors, 6" Min. Embedment.*
*Adhesive anchors shall be headless anchor bolts set in drilled holes with an Adhesive Material System in accordance with Specifications 416 and 937; drilled holes shall be 1/8" larger in diameter than the anchor bolt.
Expansion Bolts Not Permitted.

10/20/2022 8:54:37 AM

LAST REVISION 11/01/17	DESCRIPTION:	FDOT	FY 2023-24 STANDARD PLANS	FENCE TYPE B	INDEX 550-002	SHEET 3 of 3
---------------------------	--------------	------	------------------------------	--------------	------------------	-----------------

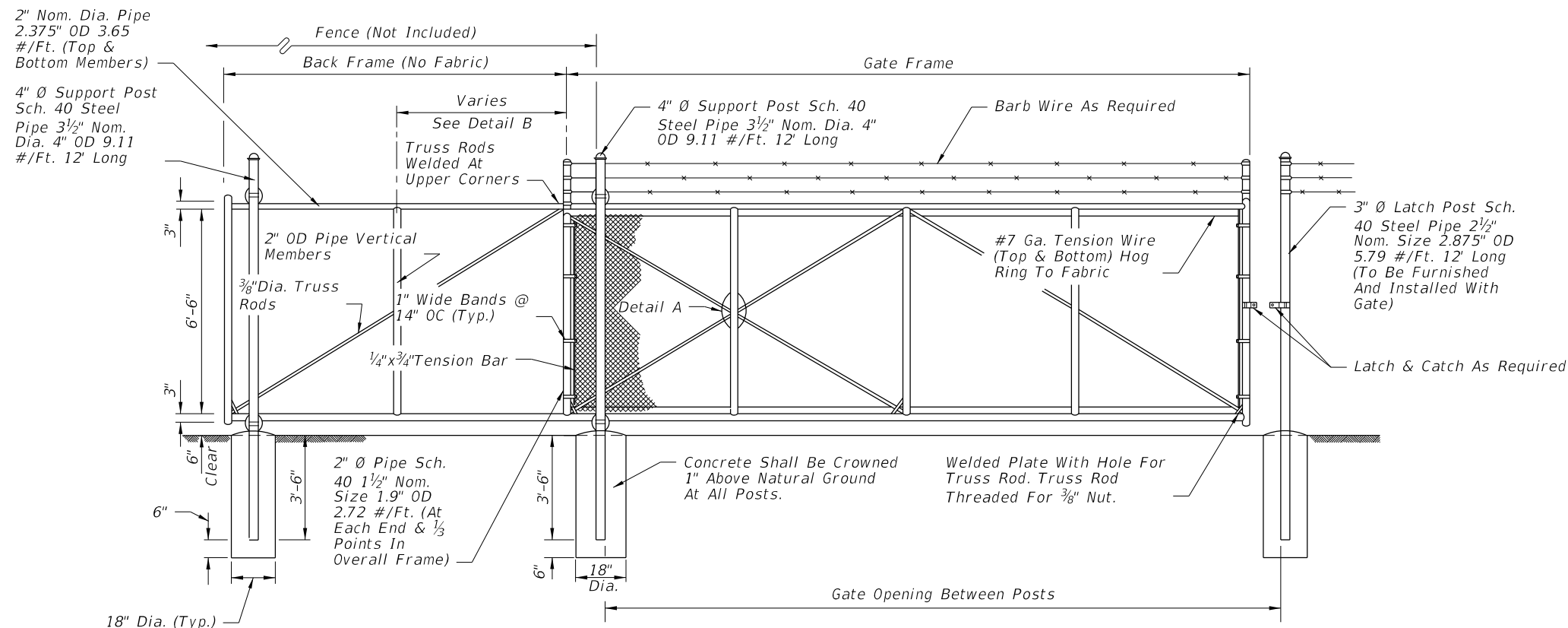

FRONT ELEVATION

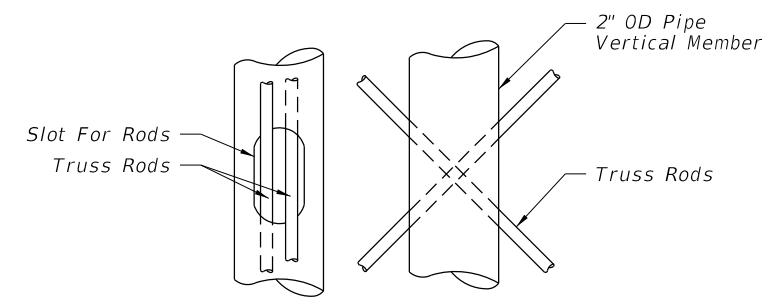

DETAIL A

GENERAL NOTES:

- Extruded, rolled or formed components that provide equal strength and stability may be used in lieu of the pipe components shown; and, internal rollers may be used in lieu of the external roller units shown.
- Gate components shall meet or exceed the protective coatings specified on Index 550-002.
- Steel gate frame shall be fabricated prior to galvanizing, except that truss rods may be fabricated following frame galvanizing provided surfaces damaged during welding are galvanized in accordance with Section 24 of AASHTO M36; or, fabricated from pipe components with protective coating meeting the requirements of Index 550-002 that are tolerant of welding (low burn back), and a protective coating applied to the weld and damaged pipe surfaces that is equivalent to the protective coating of the fabricated pipe stock.
- All fabric shall be knuckled top and bottom selvages.
- Concrete for bases shall be either Class NS concrete in accordance with Specification 347 or a packaged, dry material meeting the requirements of a concrete under ASTM C-387. Materials for Class NS concrete may be proportioned by volume and/or by weight.
- Cost of all gate components shall be included in the contract unit price for Sliding Fence Gate (Cantilever), EA.

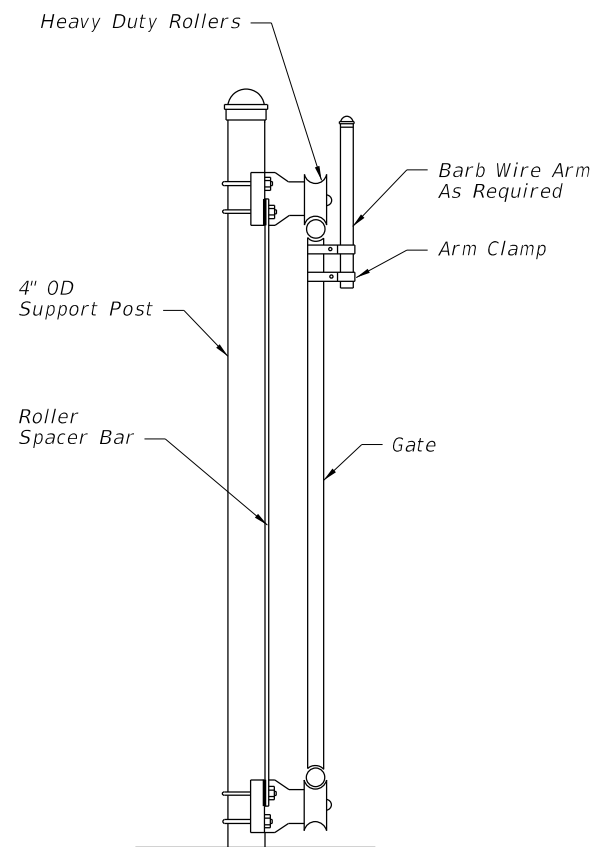

SUPPORT POST DETAIL

GATE OPENING	GATE FRAME	BACK FRAME
12'	12'-3"	6'
16'	16'-3"	8'
20'	20'-3"	10'
24'	24'-3"	12'

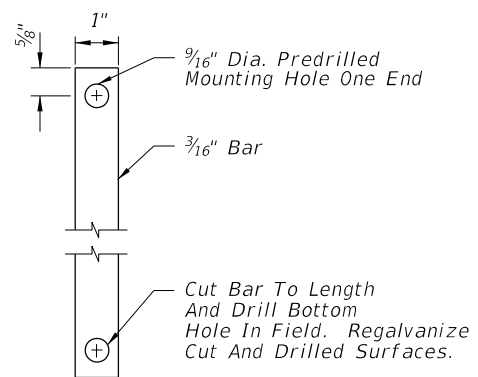

ROLLER SPACER BAR

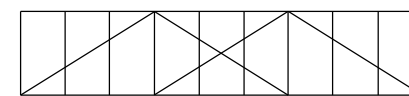

TYPICAL FRAME - 24' Opening

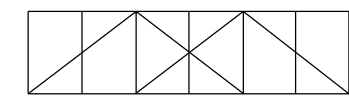

TYPICAL FRAME - 12', 16' & 20' Opening

DETAIL B

10/20/2022 8:54:36 AM

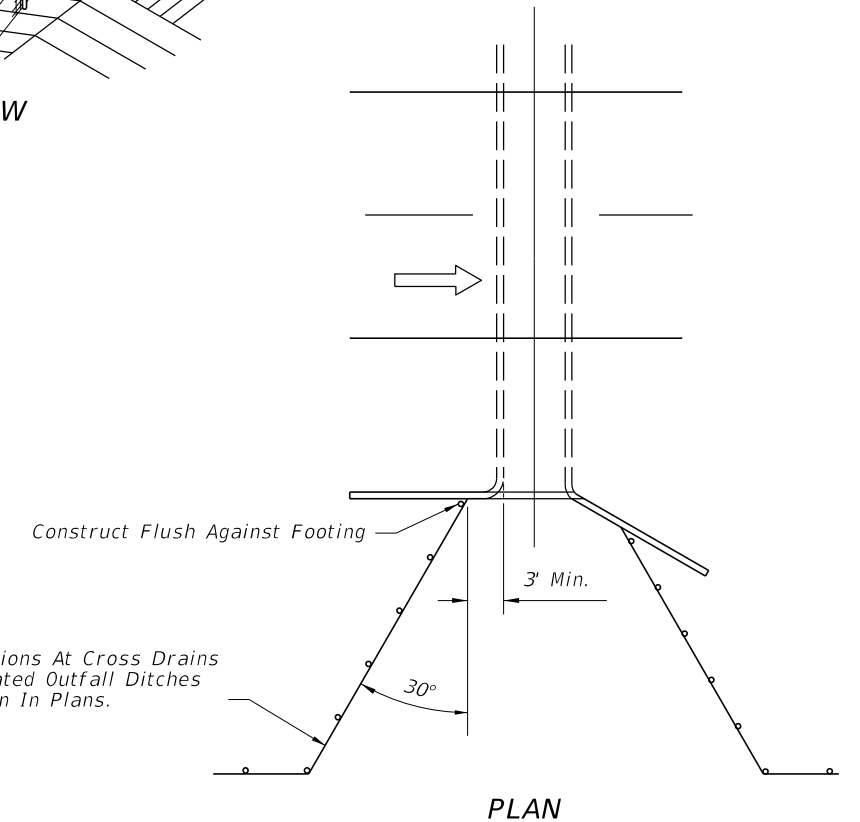
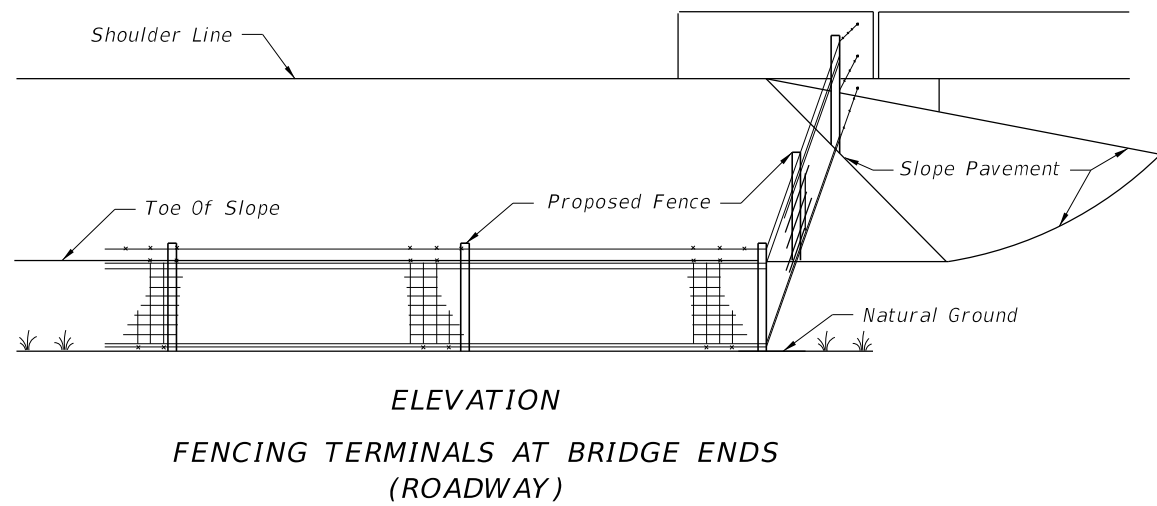
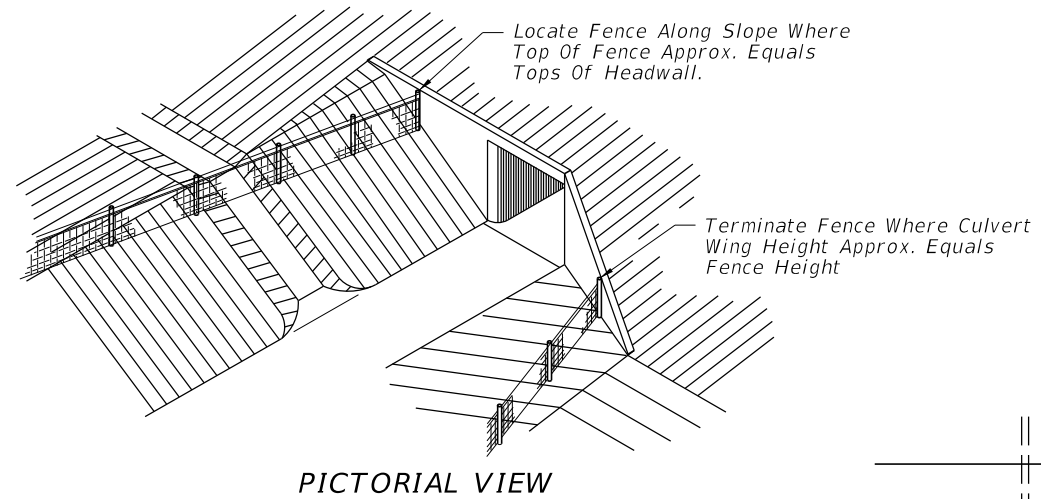
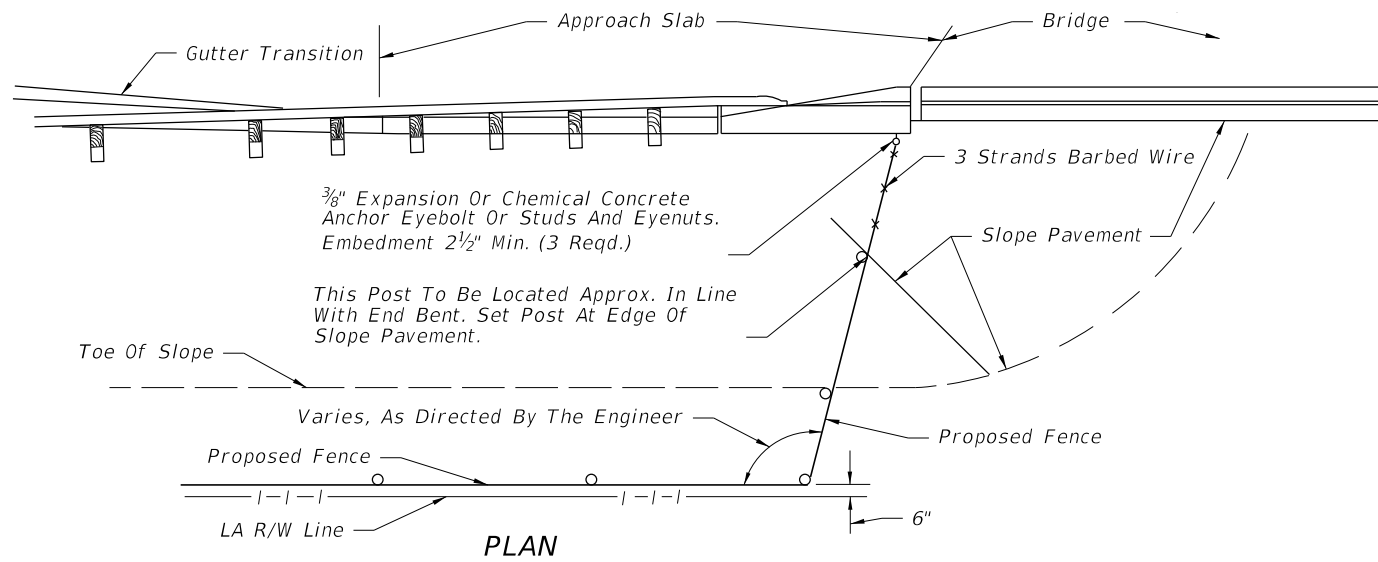

PLAN
(For Heights Of Headwall Greater Than 4')
FENCING TERMINALS AT BOX CULVERTS

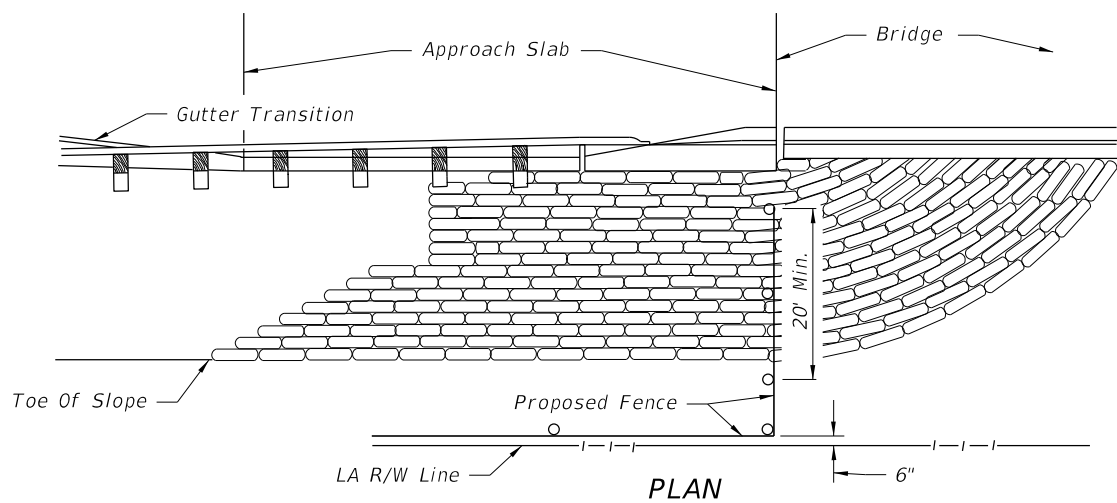

FENCING TERMINALS AT BRIDGE ENDS
(STREAM CROSSING)

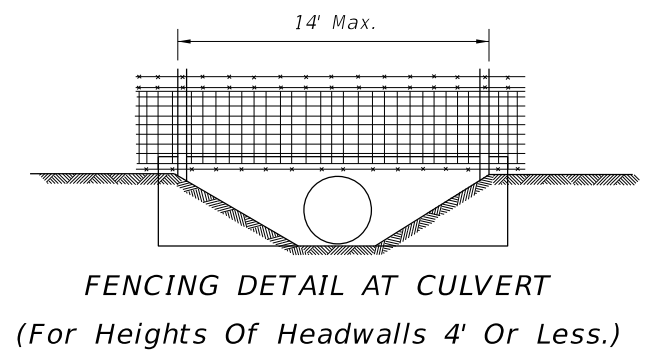
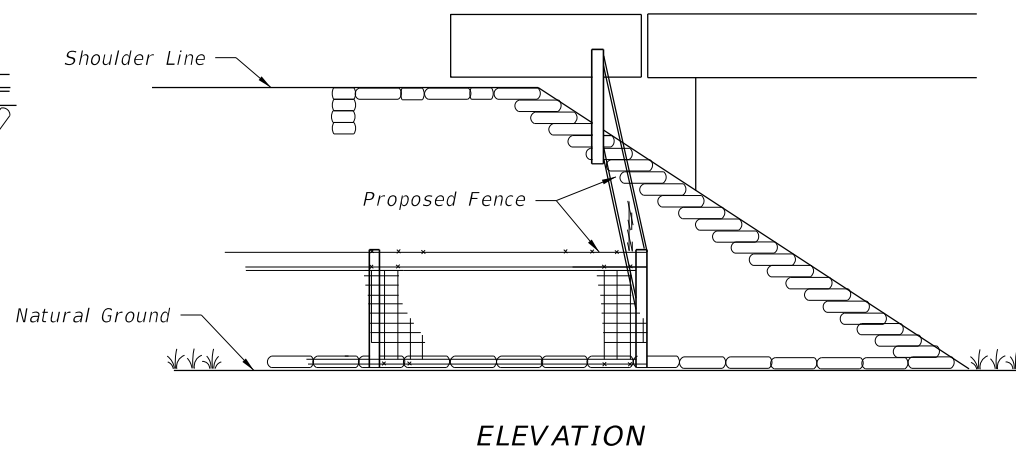

FENCING DETAIL AT CULVERT
(For Heights Of Headwalls 4' Or Less.)

Note: When height of headwall is 4' or less (drainage pipe 36" or less) the fence shall not be tied to the headwall, but shall span the lateral ditch.

10/20/2022 8:54:39 AM

LAST REVISION 11/01/17	REVISION	DESCRIPTION:		FY 2023-24 STANDARD PLANS	FENCE LOCATION	INDEX 550-004	SHEET 1 of 2
---------------------------	----------	--------------	--	------------------------------	----------------	------------------	-----------------

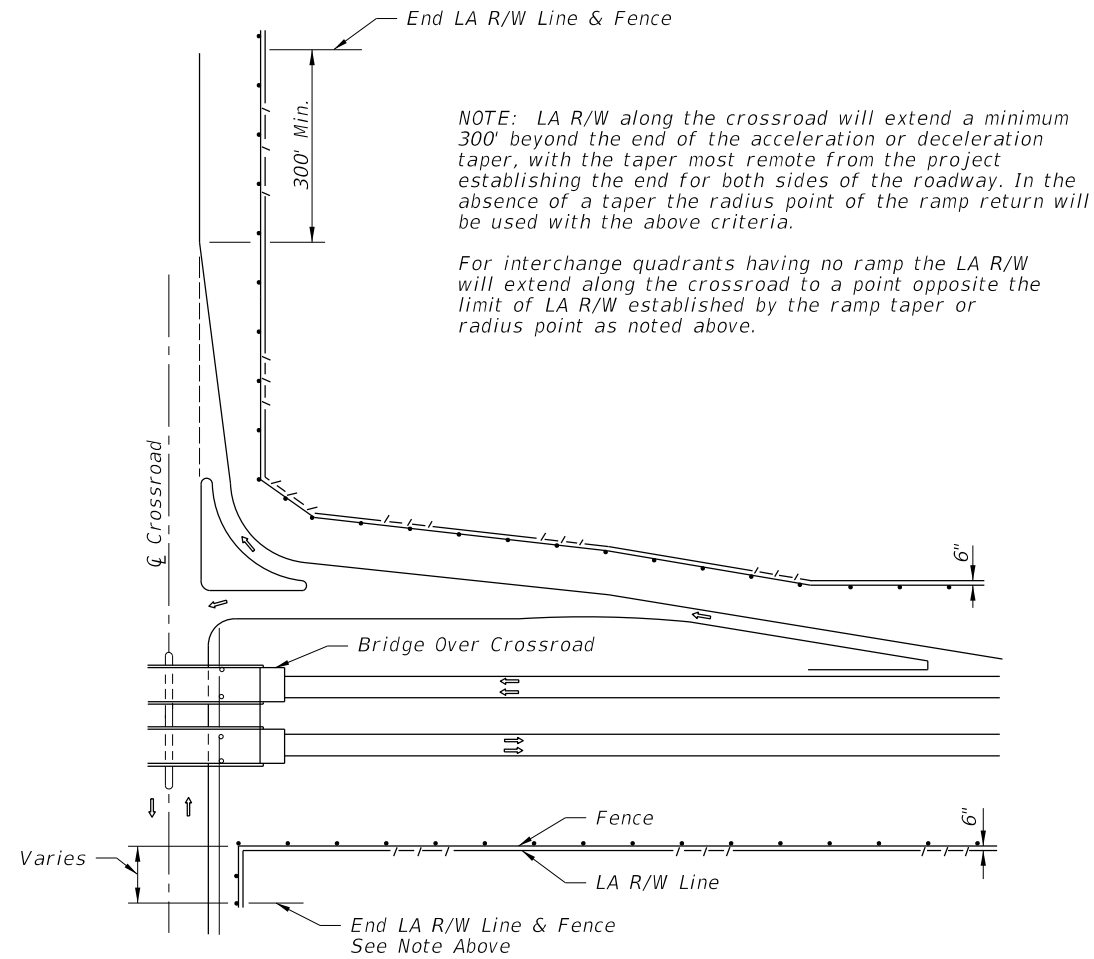

APPLIES TO BRIDGE OVER CROSSROAD AND CROSSROAD OVER FREEWAY (BRIDGE OVER CROSSROAD SHOWN)

FENCING TERMINALS AT RURAL INTERCHANGES

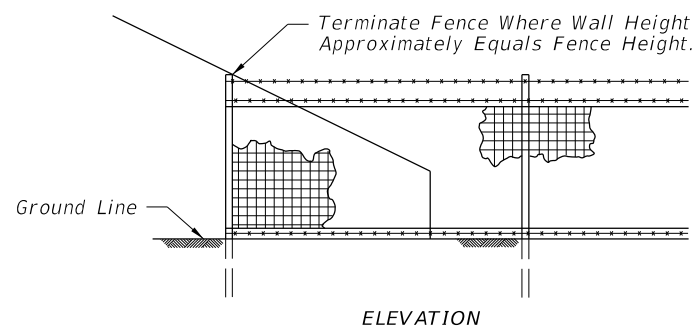
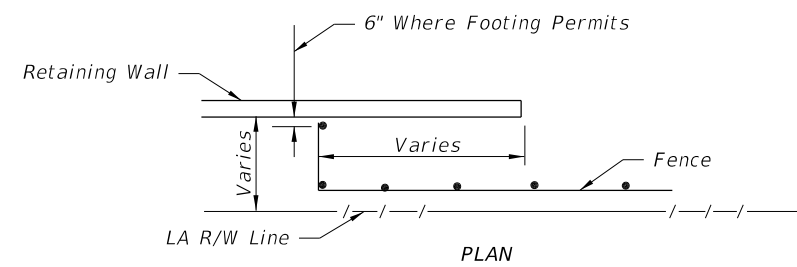

FENCING TERMINALS AT RETAINING WALLS

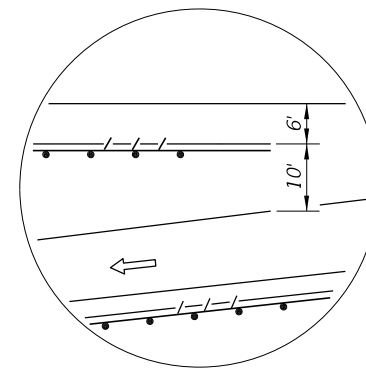

INSET A

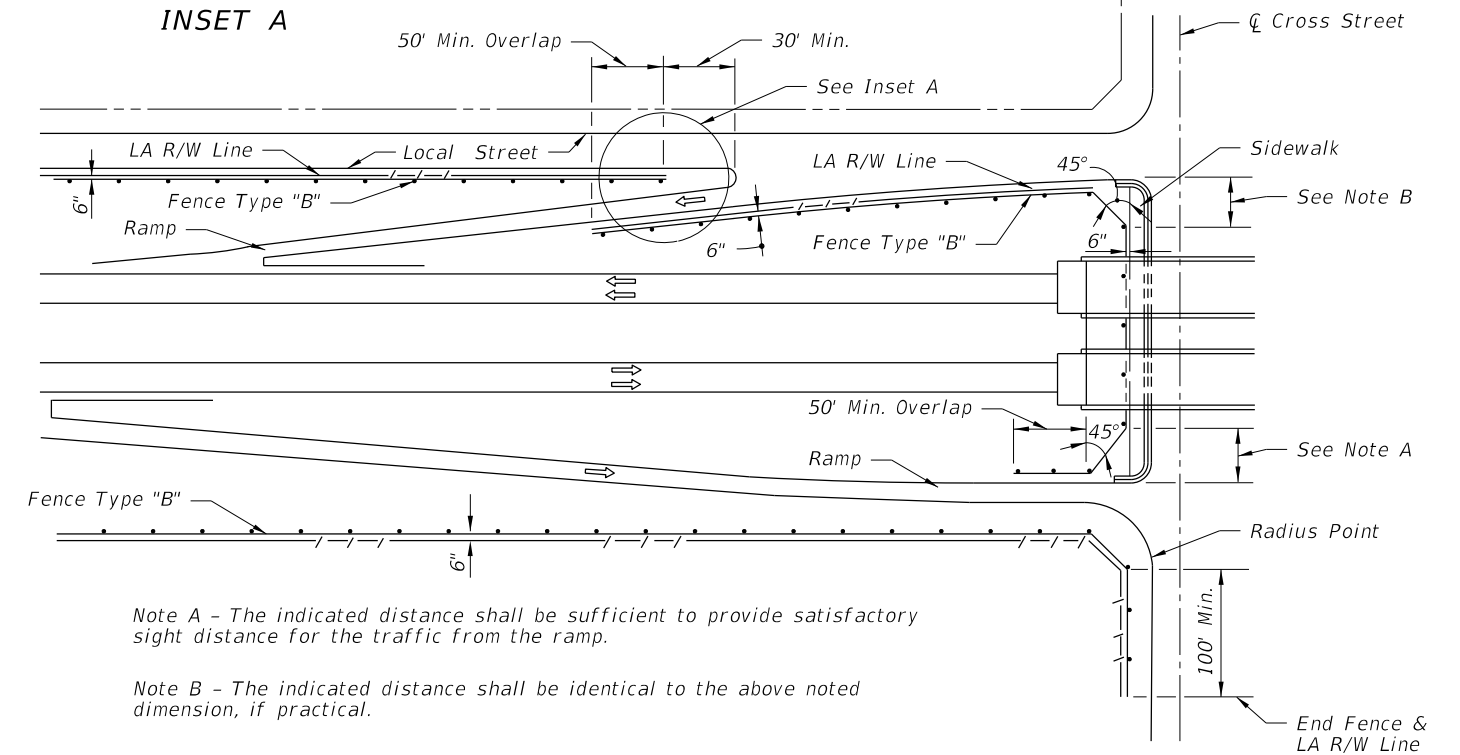

Note A - The indicated distance shall be sufficient to provide satisfactory sight distance for the traffic from the ramp.

Note B - The indicated distance shall be identical to the above noted dimension, if practical.

FENCING TERMINALS AT URBAN INTERCHANGES

10/20/2022 8:54:40 AM

LAST REVISION 11/01/17	DESCRIPTION:	 FY 2023-24 STANDARD PLANS	FENCE LOCATION	INDEX 550-004	SHEET 2 of 2
---------------------------	--------------	--	----------------	------------------	-----------------

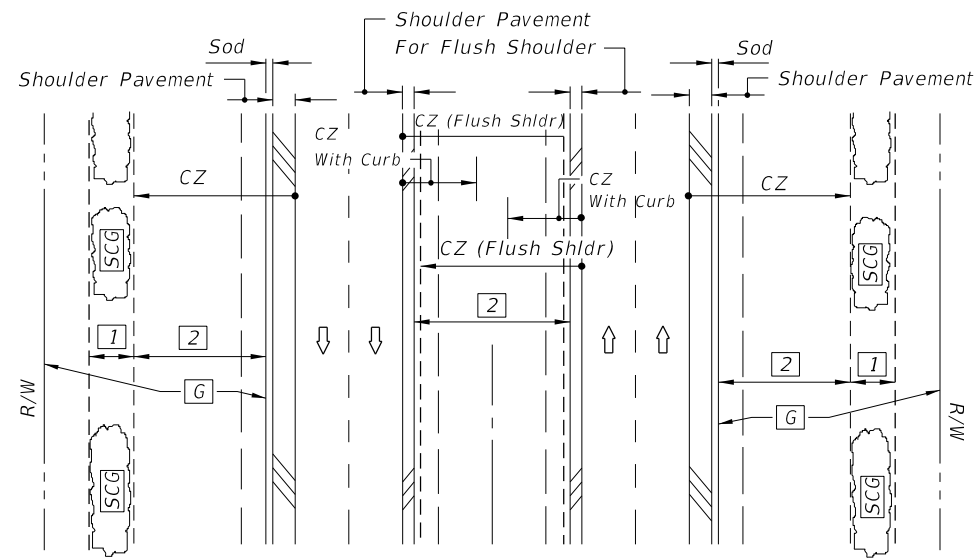

DIVIDED NARROW MEDIAN WITH OR WITHOUT CURBED MEDIAN

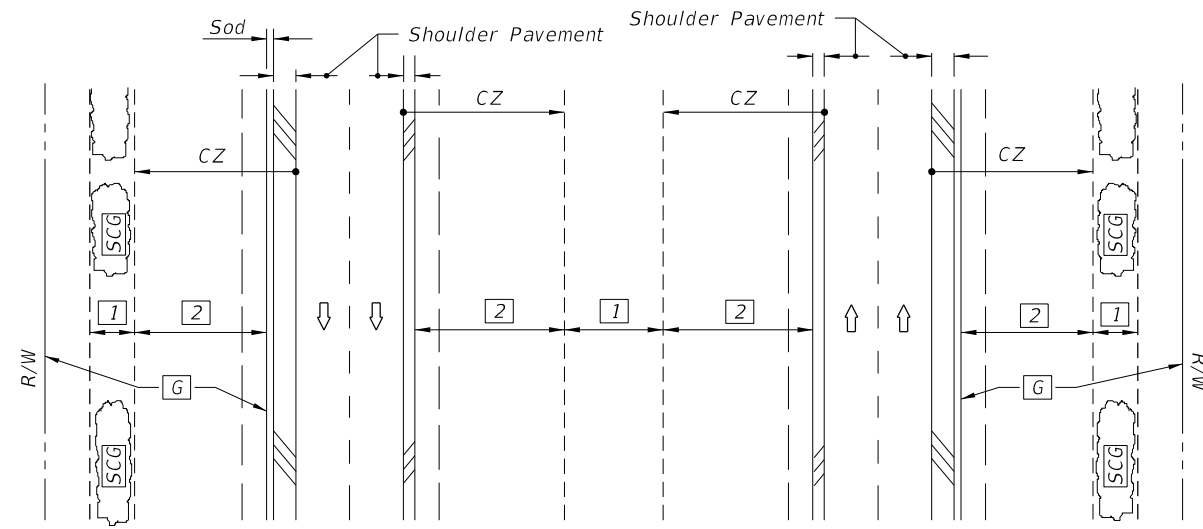

DIVIDED WIDE MEDIAN WITH OR WITHOUT CURBED MEDIAN

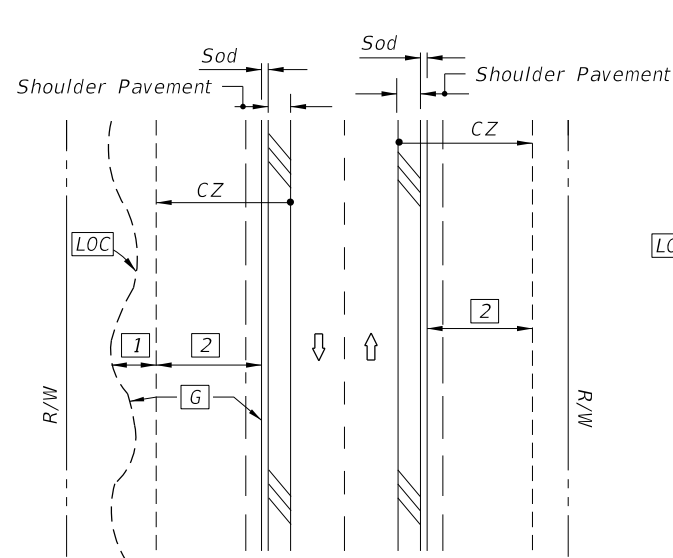

UNDIVIDED FLUSH SHOULDER

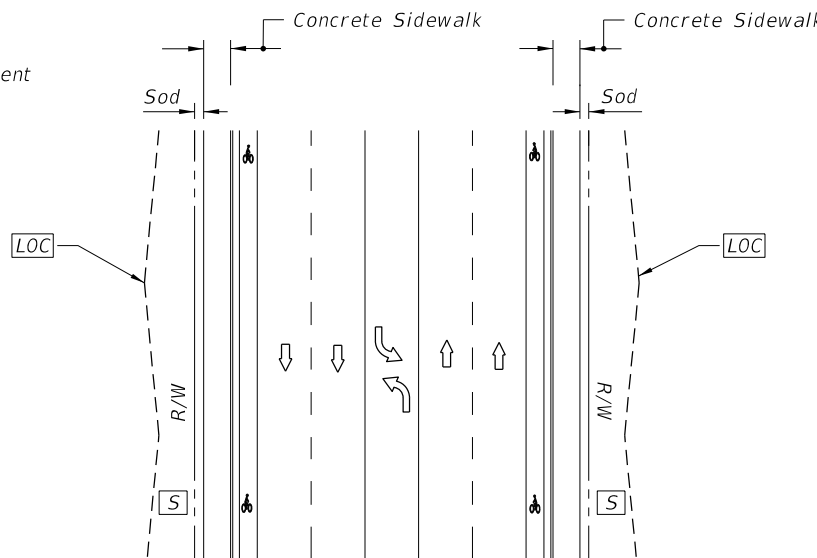

UNDIVIDED CURBED

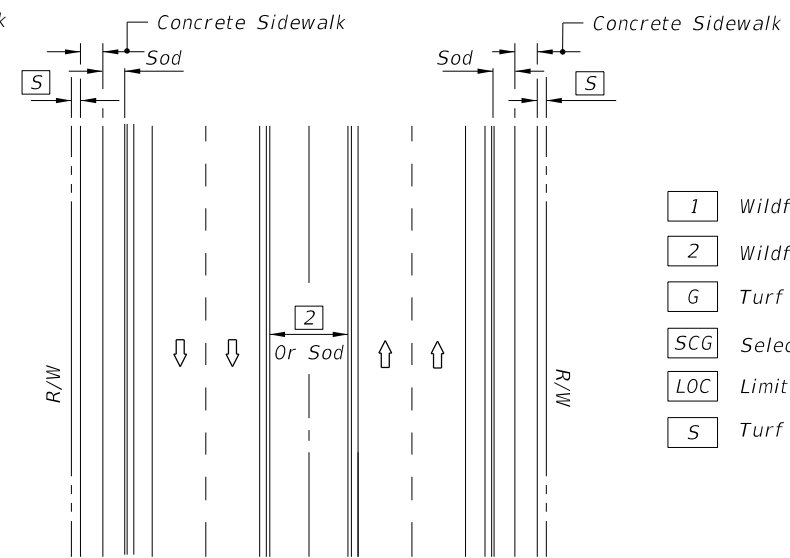

DIVIDED CURBED

- LEGEND**
- 1 Wildflower Group #1
 - 2 Wildflower Group #2
 - G Turf (To Limit of Construction)
 - SCG Selective Clearing And Grubbing
 - LOC Limits Of Construction
 - S Turf

WILDFLOWER SEEDING RATES	
Common Name (Botanical Name)	lbs/ac
#1 Group	
Black-Eyed Susan (<i>Rudbeckia hirta</i>)	2
Lance-Leaf Tickseed (<i>Coreopsis lanceolata</i>)	10
Goldenmane Tickseed (<i>Coreopsis basalis</i>)	10
Leavenworth's Tickseed (<i>Coreopsis leavenworthii</i>)	10
Fire Wheel (<i>Gaillardia pulchella</i>)	10
Softhair Coneflower (<i>Rudbeckia mollis</i>)	2
Crimson Clover (<i>Trifolium incarnatum</i>)	15
#2 Group	
Annual Phlox (<i>Phlox drummondii</i>)	10
Moss Verbena (<i>Verbena tenuisecta</i>)	6
Leavenworth's Tickseed (<i>Coreopsis leavenworthii</i>)	10
Fire Wheel (<i>Gaillardia pulchella</i>)	10
Crimson Clover (<i>Trifolium incarnatum</i>)	15
Note: Wildflower seeding rates are for restoring impacted wildflower areas.	

GENERAL NOTES

- All turf establishment shall be performed meeting the requirements of Specification 570.
- Activities such as clearing, grading, and excavating that will disturb one or more acres of land require coverage under the Generic Permit for Stormwater Discharge from Large and Small Construction Activities from the Florida Department of Environmental Protection, and implementation of appropriate pollution prevention measures to minimize erosion and sedimentation and properly manage stormwater.
- Confirm compatibility of wildflower with Seeding Zones.

SEEDING ZONES

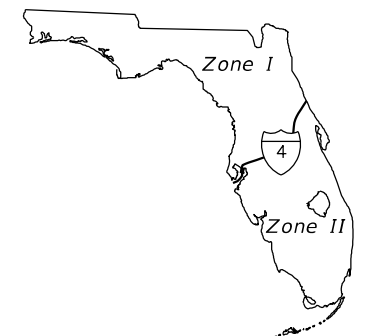

10/20/2022 8:54:41 AM

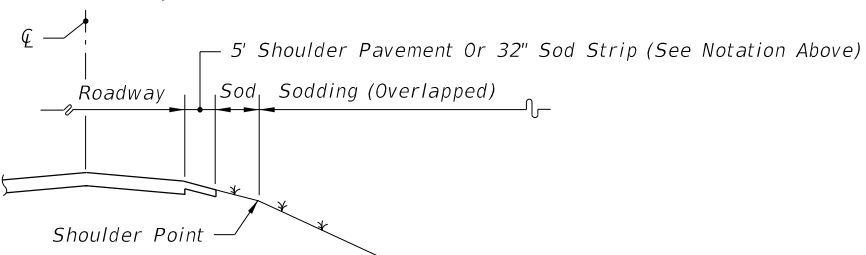
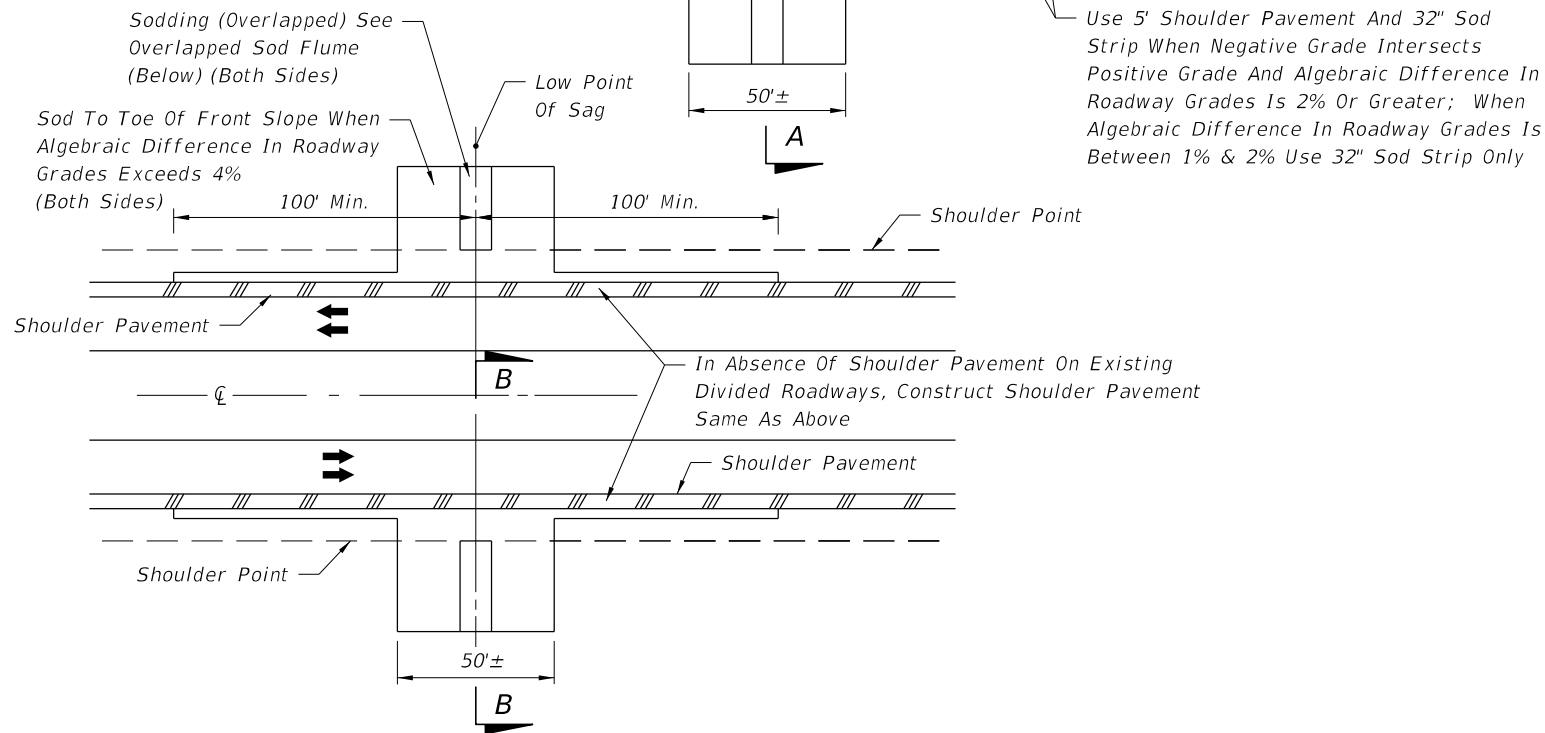
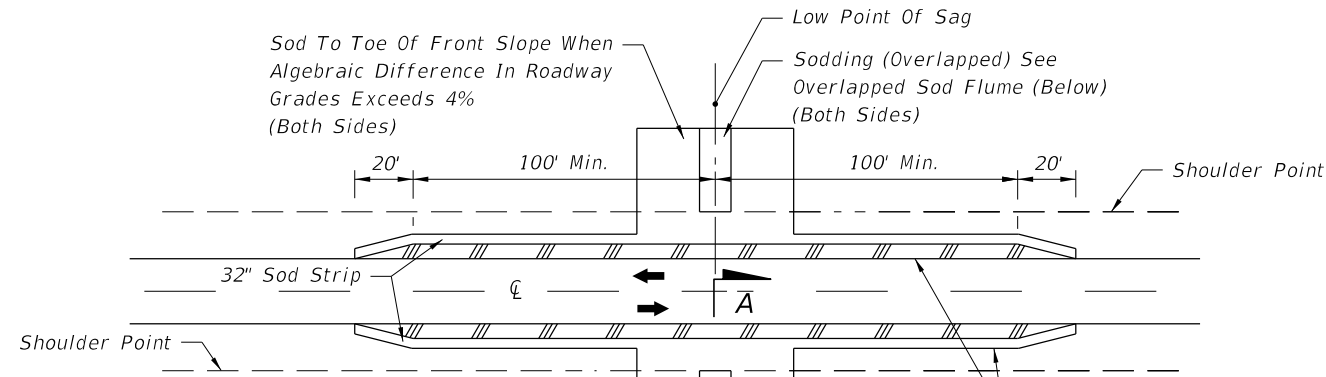

SECTION AA
(Symmetrical About \mathcal{Q})

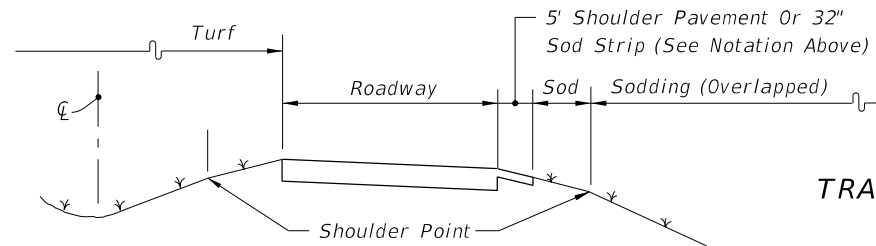

SECTION BB
(Symmetrical About \mathcal{Q})

SHOULDER AND SLOPE TREATMENT IN SAG VERTICAL CURVES

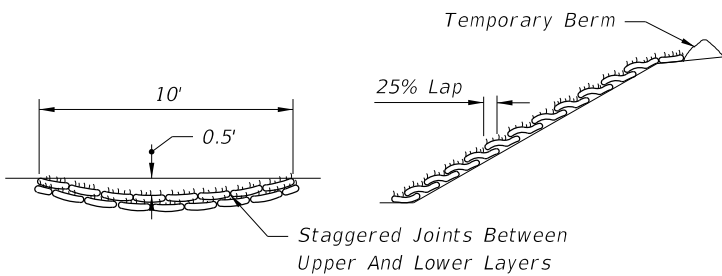

TRANSVERSE SECTION LONGITUDINAL SECTION
OVERLAPPED SOD FLUME

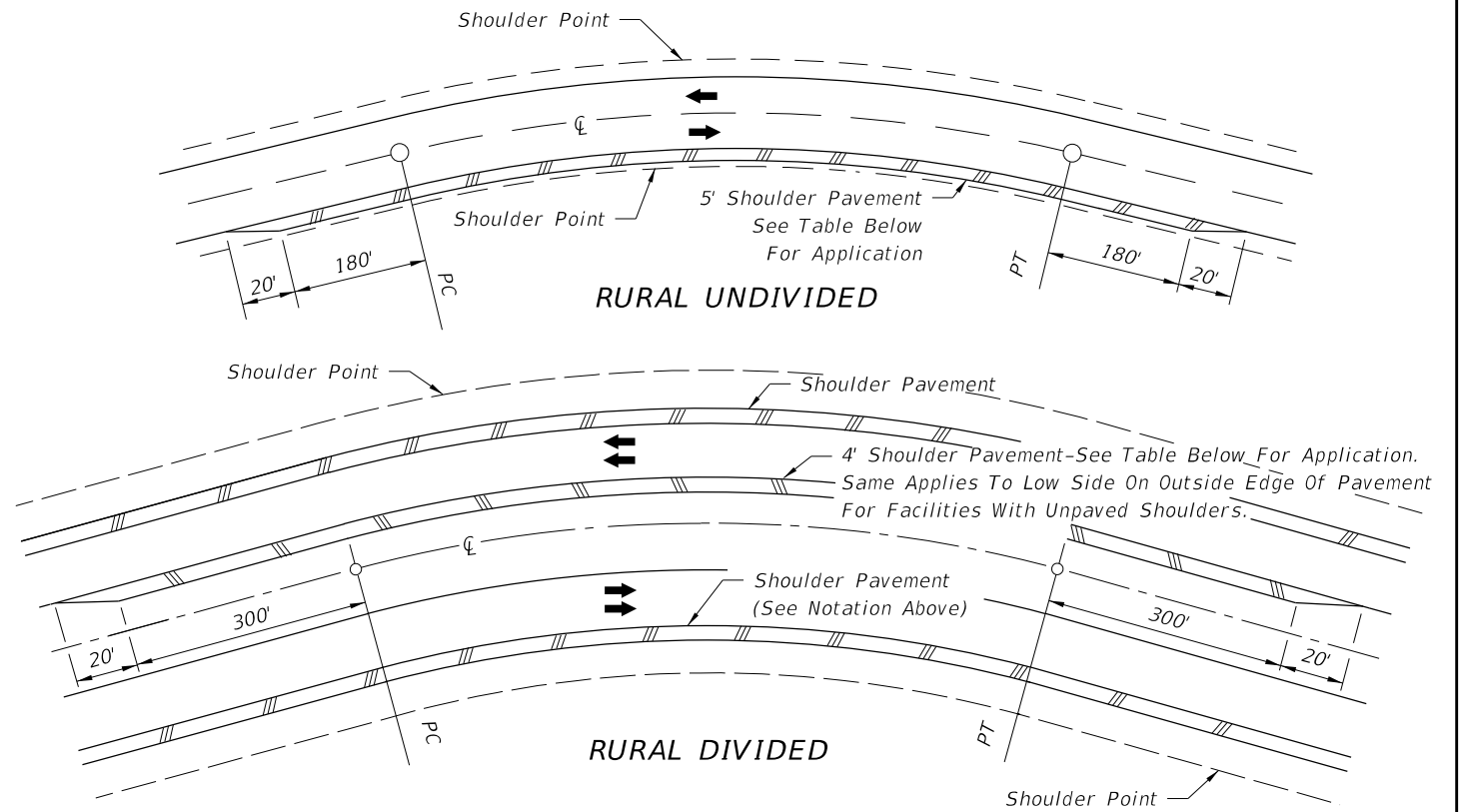

CRITERIA FOR PAVING SHOULDER ON DIVIDED AND UNDIVIDED FACILITIES		
Design Speed (mph)	Degree Of Curve	Note: Shoulder Pavement is required on all curves meeting the criteria tabulated. For curves not meeting the criteria, shoulders are to be paved where erosion of the shoulder is evident or anticipated.
30	7° Or Greater	
40	5° Or Greater	
50	4° Or Greater	
60	3° Or Greater	
65	3° Or Greater	
70	2° Or Greater	

SHOULDER AND SLOPE TREATMENT FOR SUPERELEVATED ROADWAYS

NOTES:

1. These treatments are applicable to new construction, reconstruction and RRR projects. Project requirements for shoulder pavement and sodding that exceed the limits of this standard take precedence.
2. For sodding adjacent to ditches and at headwalls, see Index 524-001.
3. All front slopes steeper than 1:3 are to be sodded.

TREATMENTS FOR PROTECTION FROM CONCENTRATED ROADWAY RUNOFF EROSION AND SHOULDER RAVELING

10/20/2022 8:54:42 AM

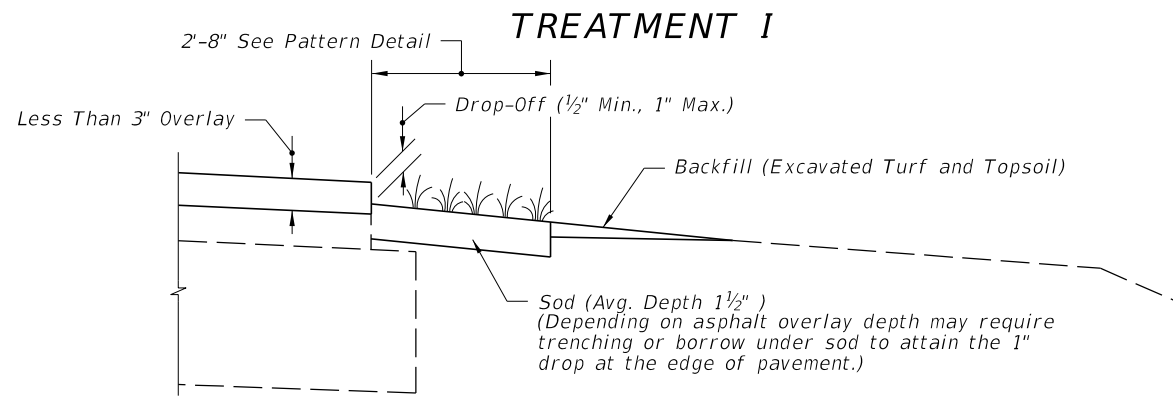

COMPLETED SHOULDER

CRITERIA FOR USING TREATMENT I

- Project ___
- is resurfacing, widening and resurfacing or construction of shoulder pavement
 - is rural or is urban without curb and gutter
 - resurfacing build-up is less than 3"

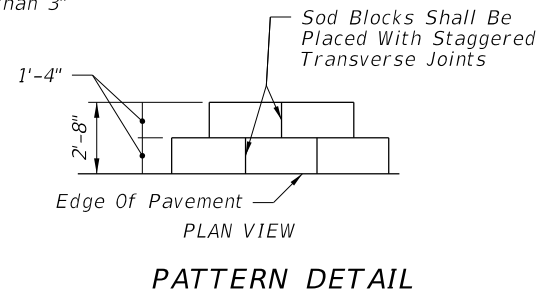

GENERAL NOTES

1. Treatment I:

If trenching under sod is necessary to achieve the required Drop-Off, excavated topsoil is to be used for filling voids and low areas at the edge of pavement or for flushing along the edge of sod. Excess material to be uniformly distributed over the shoulder.

2. Treatment II:

A. Borrow must meet the requirements for a "Select" material in accordance with Index 120-001 and Specification 120.

B. Borrow may be used in lieu of excavated turf and topsoil when economically feasible. There will be no additional payment for substituting borrow for excavated turf and topsoil.

3. Special attention is to be directed at achieving the required Drop-Off at the edge of pavement, within the dimension range shown.

4. Activities such as clearing, grading, and excavating that will disturb one or more acres of land require coverage under the Generic Permit for Stormwater Discharge from Large and Small Construction Activities from the Florida Department of Environmental Protection, and implementation of appropriate pollution prevention measures to minimize erosion and sedimentation and properly manage stormwater.

5. Turf Establishment:

A. Wildflowers destroyed by shoulder sodding and turf operations are to be reestablished under the seeding rates prescribed for permanent wildflower #2 Group shown by table on Index 570-001.

B. Establish turf in accordance with Specification 570.

TREATMENT II

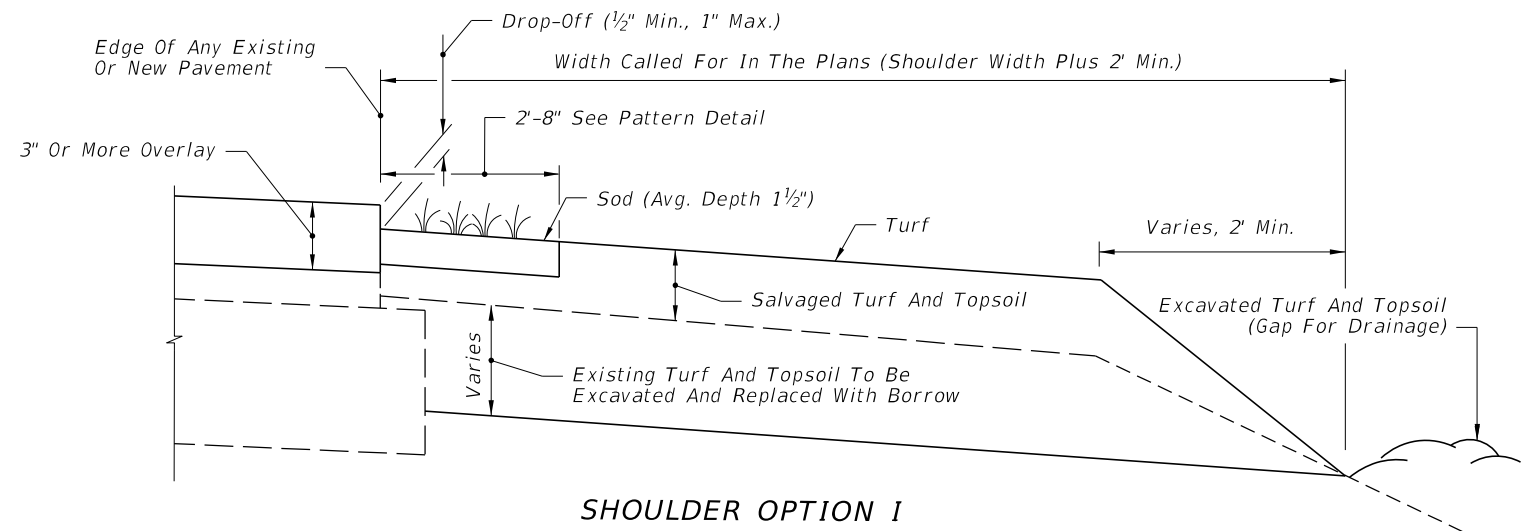

SHOULDER OPTION 1

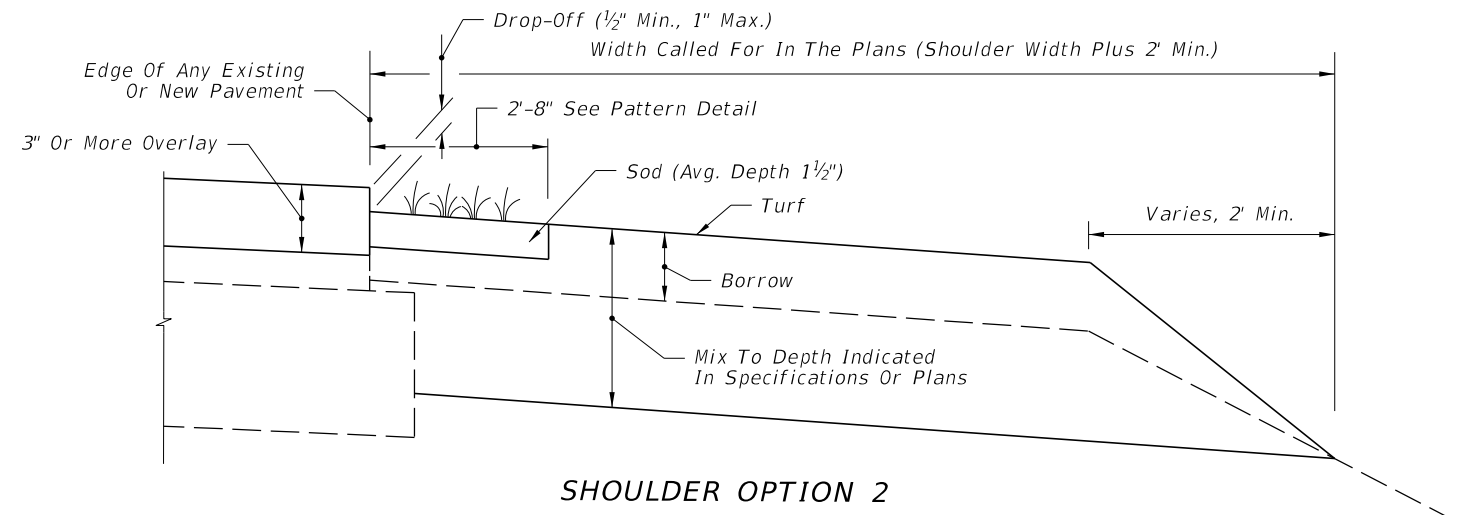

SHOULDER OPTION 2

CRITERIA FOR USING TREATMENT II

- Project ___
- is resurfacing or construction of shoulder pavement
 - is rural or is urban without curb and gutter
 - resurfacing build-up is 3" or more

A SIMILAR TREATMENT MAY BE USED FOR PROJECTS THAT REQUIRE SHOULDER WIDENING. DETAILS ARE TO BE SHOWN IN THE PLANS.

10/20/2022 8:54:44 AM

LAST REVISION 11/01/18	REVISION	DESCRIPTION:		FY 2023-24 STANDARD PLANS	SHOULDER SODDING AND TURF ON EXISTING FACILITIES	INDEX 570-010	SHEET 1 of 1
---------------------------	----------	--------------	--	------------------------------	---	------------------	-----------------

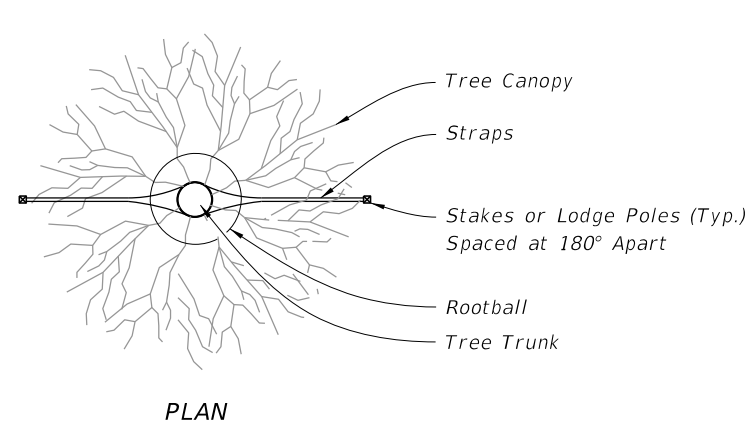

PLAN

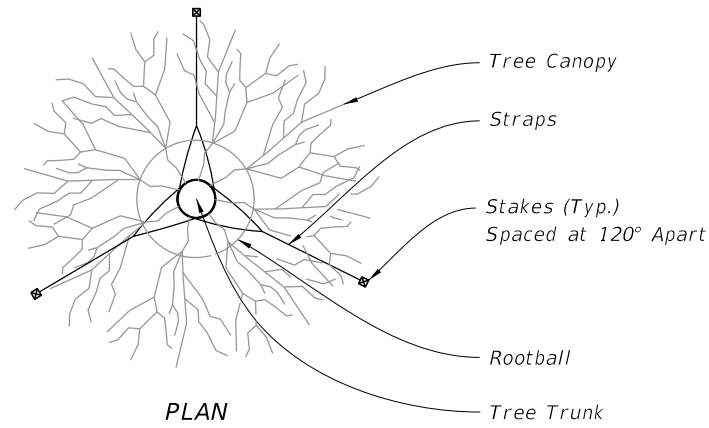

PLAN

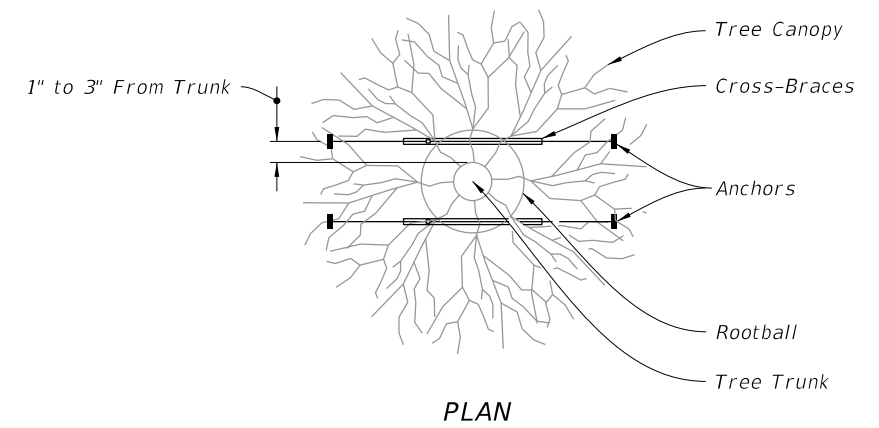

PLAN

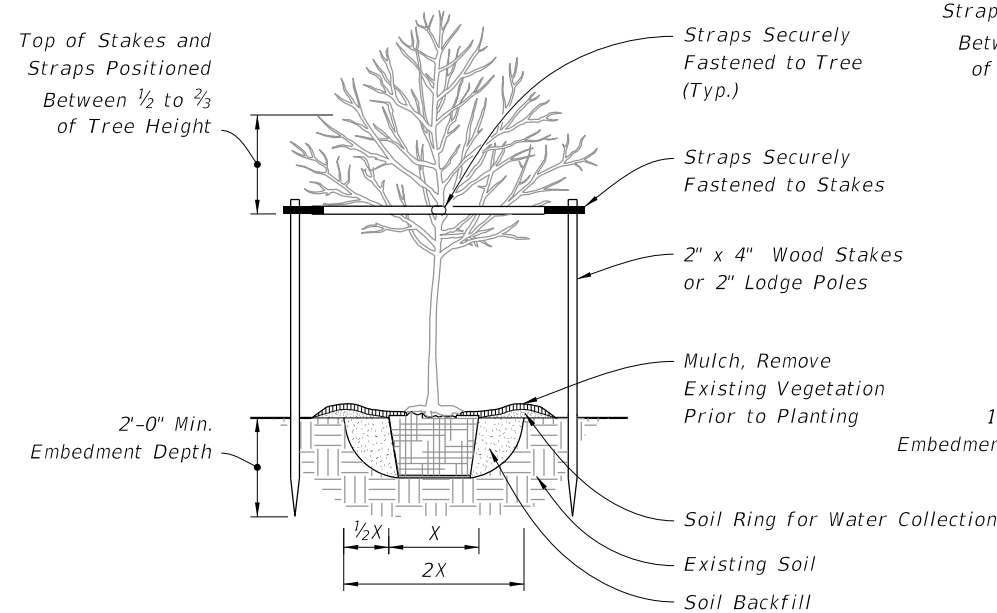

ELEVATION

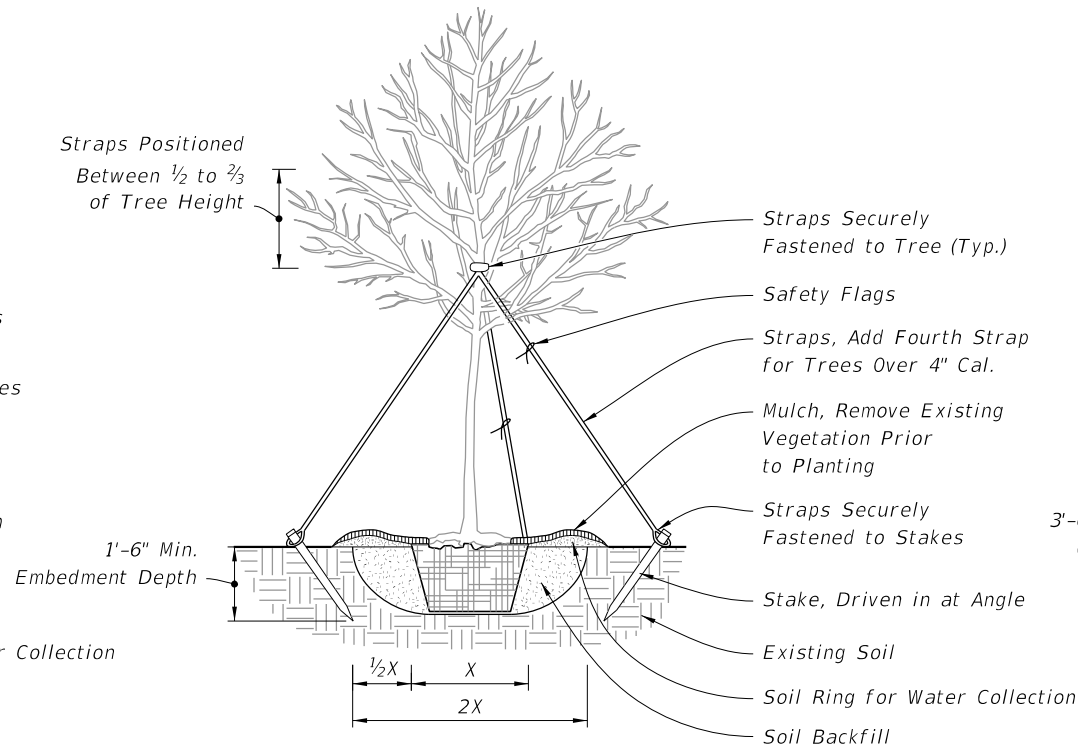

ELEVATION

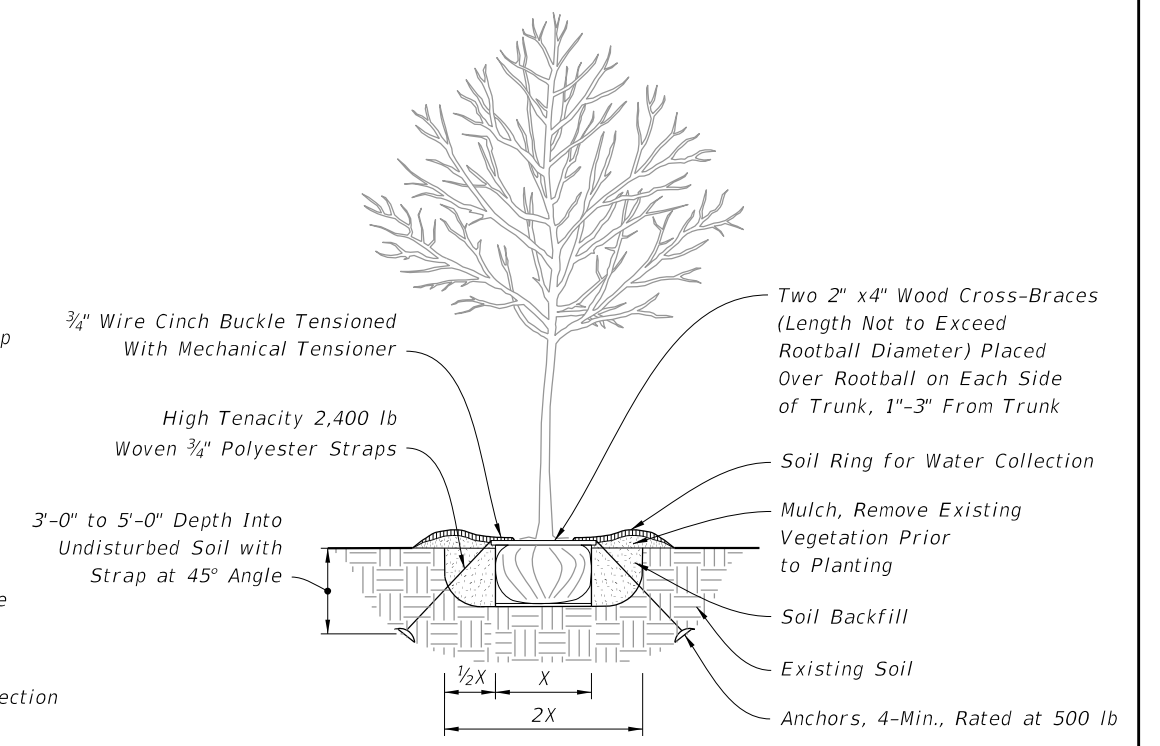

ELEVATION

UNDER 2 1/2" CALIPER TREE PLANTING

2 1/2" TO 6" CALIPER TREE PLANTING

UNDER 4" CALIPER TREE PLANTING WITH UNDERGROUND BRACING

GENERAL NOTES:

1. Staking guidelines are based on standard horticultural requirements and are provided for plant establishment purposes only. Details not intended to apply when bracing is intended to address safety considerations. When bracing for safety, refer to Designer generated signed and sealed details. These guidelines are not intended to apply when the tree or palm is within falling distance of a roadway, pedestrian or bicycle route, under extreme wind loads, non-standard soil properties, non-standard plant dimensions, or when rootball is anticipated to be greater than 4 feet diameter and planted on 1:3 slope or steeper.
2. All dimensions 6" and less are exaggerated for illustrative purposes only. Dimensions shown for wood materials are nominal. Slopes shown are Vertical:Horizontal.
3. Remove plant containers prior to planting. Remove a minimum of the top 1/3 of burlap, fabric, or wire mesh for plants not grown in containers.
4. Allow no more than 1" of soil to cover the uppermost root on all trees. Set the top of rootball 1"-2" above finish grade after settling and set plumb to the horizon.
5. Backfill with loosened existing soil or as shown in the plans. Remove rocks, sticks, or other deleterious material greater than 1" in any direction prior to backfilling. Water and tamp to remove air pockets. Contact the Engineer prior to planting if existing soils contain excessive sand, clay, or other material not conducive to proper plant growth.
6. Construct soil rings at the outer edge of the planting pit with a height of 3" and gently sloping sides unless a permanent, subsurface or drip irrigation system is provided. Do not pile soil on top of rootball.
7. Construct a 3" deep layer of mulch placed 2" off the edge of the trunk flare, around the base of shrub, or solidly around ground cover. Never pile mulch against the tree trunk.
8. Install guying with minimum 1" wide nylon or polypropylene straps with a minimum 600 lb. break strength. Check straps monthly and adjust as required to eliminate girdling of tree. Locate all wood stakes beyond the edge of soil ring in existing soil and embed a minimum of 18" below finished grade unless otherwise specified. Alternate tree bracing and guying systems specified or approved by the Engineer may be used in lieu of the tree bracing and guying methods detailed on the Index.
9. Relocated Trees and Palms: Brace relocated trees and palms in accordance with the Contract Documents. Remove bracing at the conclusion of the contract or as directed by the Engineer. Bracing or straps must not damage or become embedded in the tree bark.
10. Use 2" x 2" minimum wood stakes unless otherwise shown in the Plans or directed by the Engineer. Use wood meeting #2 Common or better in accordance with the Standard Grading Rules for Southern Pine.
11. Drive stakes into existing, undisturbed soil. Localized compaction may be provided to prevent displacement of the stakes for previously disturbed existing soils that do not provide sufficient stability.

10/20/2022 8:54:45 AM

LAST REVISION 11/01/19	REVISION	DESCRIPTION:	 FY 2023-24 STANDARD PLANS	LANDSCAPE INSTALLATION	INDEX 580-001	SHEET 1 of 2
---------------------------	----------	--------------	---	------------------------	------------------	-----------------

2 x 4 Wood Braces
(Minimum of Three Wood Braces) Spaced at 120° Apart. Saw Cut Ends at Proper Angle to Allow for Flush Connection to Batten.
Nail or Screw Braces Securely to Wood Batten or Manufactured Tree Bracing.

For Palms Over 24' Clear Trunk, Increase Wood Braces to 4" x 4" Minimum, Use a Minimum of Four Braces With Minimum Length of 16' Spaced

Mulch, Remove Existing Vegetation Prior to Planting

Soil Ring for Water Collection

Wood Stake (Typ.)

Existing Soil

Soil Backfill

ELEVATION

Batten: Wood or Manufactured Tree Bracing System (Typ.) See DETAIL "A"

See DETAIL "B"

1/3 of Trunk Height Min.

2'-6" Min. Embedment Depth

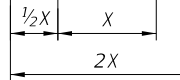

Minimum Of Three Wood Braces Spaced at 120° Apart with Optional Fourth Wood Brace. Saw Cut Ends at Proper Angle to Allow for Flush Connection to Batten. Nail or Screw Braces Securely to Wood Batten or Manufactured Tree Bracing System. For Palms Over 24' Increase Wood Brace to 4" x 4" Minimum, Use a Minimum of Four Braces With Minimum Length of 16'.

Place Top of Root Ball 2" Above Projected Slope

Soil Ring for Water Collection

1:3 Max.

Wood Stake (Typ.)

Existing Soil

Soil Backfill

ELEVATION

Fourth Brace for Palms Over 24'

Mulch, Remove Existing Vegetation Prior to Planting

1/3 of Trunk Height Min.

Horizon Line

2'-6" Min. Embedment Depth



NOTE: May be used on large caliper canopy trees pending slope and rootball width, adjust banding every 6 months or as needed (for fast growing species) to prevent girdling.

PALM PLANTING

PALM PLANTING ON SLOPE

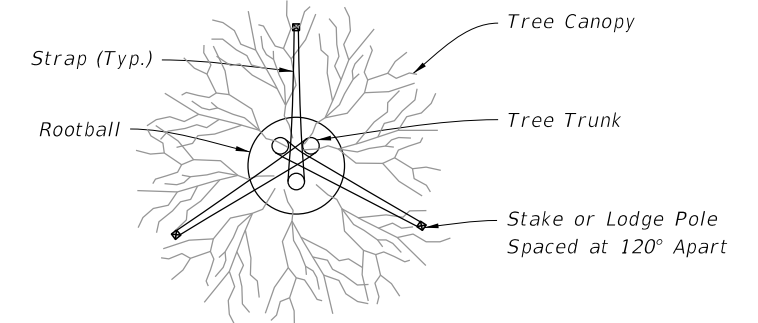

PLAN

Straps Securely Fastened to Stakes

Straps Securely Fastened to Tree (Typ.)

Mulch, Remove Existing Vegetation Prior to Planting

Soil Ring for Water Collection

Existing Soil

Soil Backfill

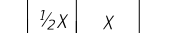

ELEVATION

Top of Stakes and Straps Positioned between 1/2 to 1/3 of Tree Height

Three 2" x 4" Wood Stakes or 2" Lodge Poles (Typ.)

2'-0" Min. Embedment Depth

MAX 10' HT. MULTI-TRUNK TREE PLANTING

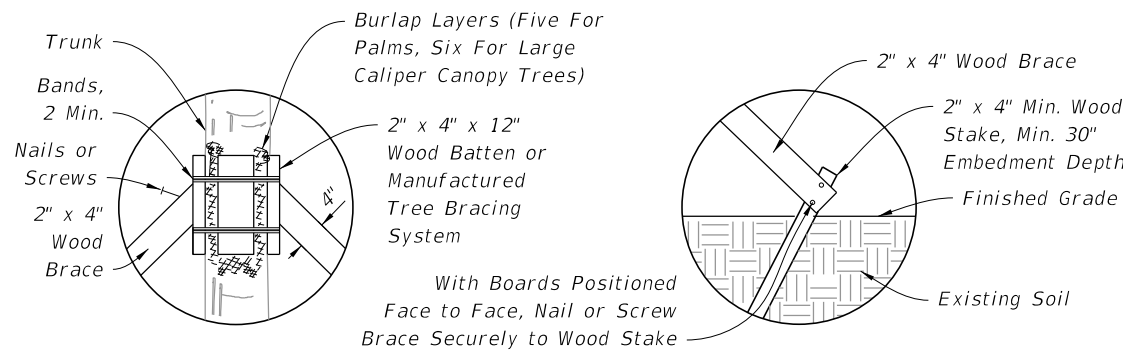

NOTE: Install bands and couplings that are rated a min. 900 lb. tensile strength, and are corrosion and UV resistant.

NOTE: Stake Into Firm, Existing Soil.

DETAIL "A"

DETAIL "B"

Straps Securely Fastened to Tree (Typ.)

Straps Securely Fastened to Stakes

Place Root Flare 2" Above Projected Slope

1:3 Max.

Undisturbed or Compacted Soil

Soil Backfill

ELEVATION

Two 2" x 4" Wood Stakes or 2" Lodge Poles (Typ.) Spaced at 180° Apart

Top of Stakes and Straps Positioned between 1/2 to 1/3 of Tree Height

Mulch, Remove Existing Vegetation Prior to Planting

Horizon Line

2'-0" Min. Embedment Depth

Soil Ring for Water Collection

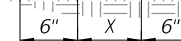

UNDER 2 1/2" CALIPER TREE PLANTING ON SLOPE

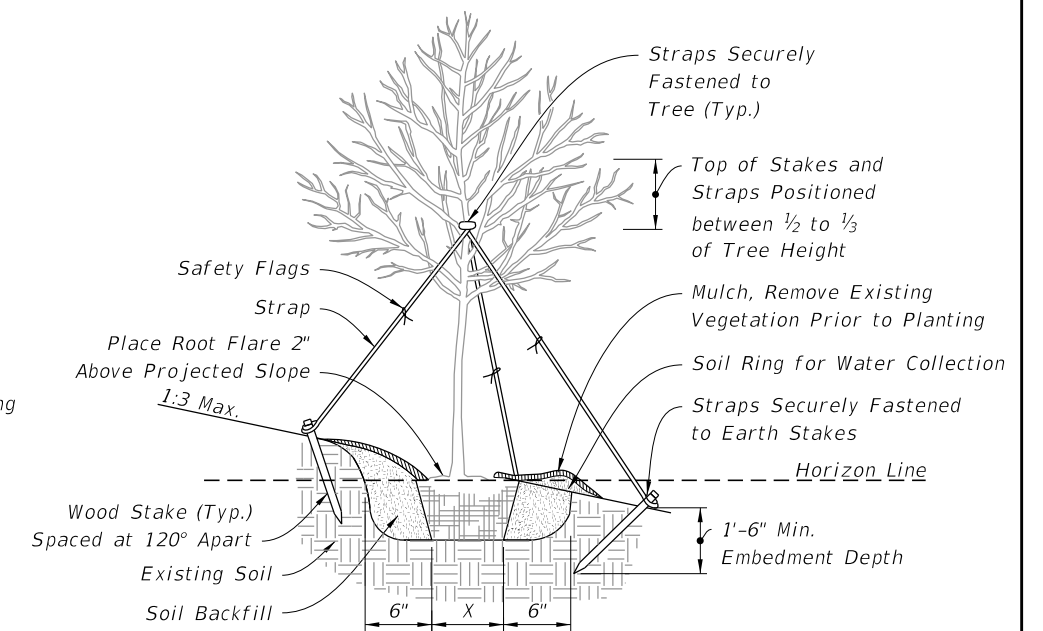

ELEVATION

2 1/2" TO 6" CALIPER TREE PLANTING ON SLOPE

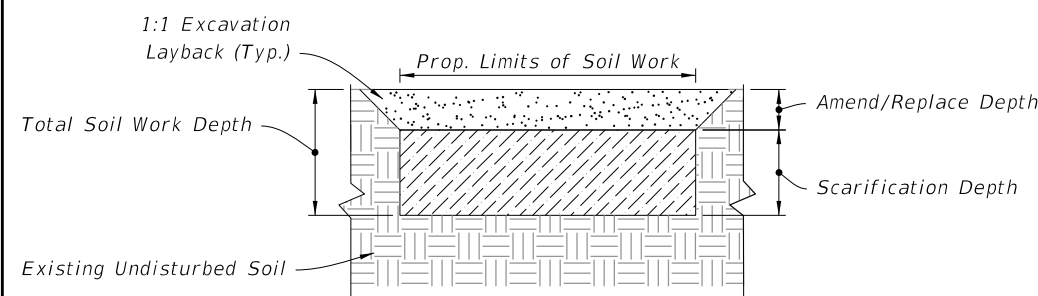

(Typical Section)
LANDSCAPE SOIL WORK

10/20/2022 8:54:46 AM

LAST REVISION 11/01/19	REVISION	DESCRIPTION:	FDOT	FY 2023-24 STANDARD PLANS	LANDSCAPE INSTALLATION	INDEX 580-001	SHEET 2 of 2
---------------------------	----------	--------------	------	------------------------------	------------------------	------------------	-----------------

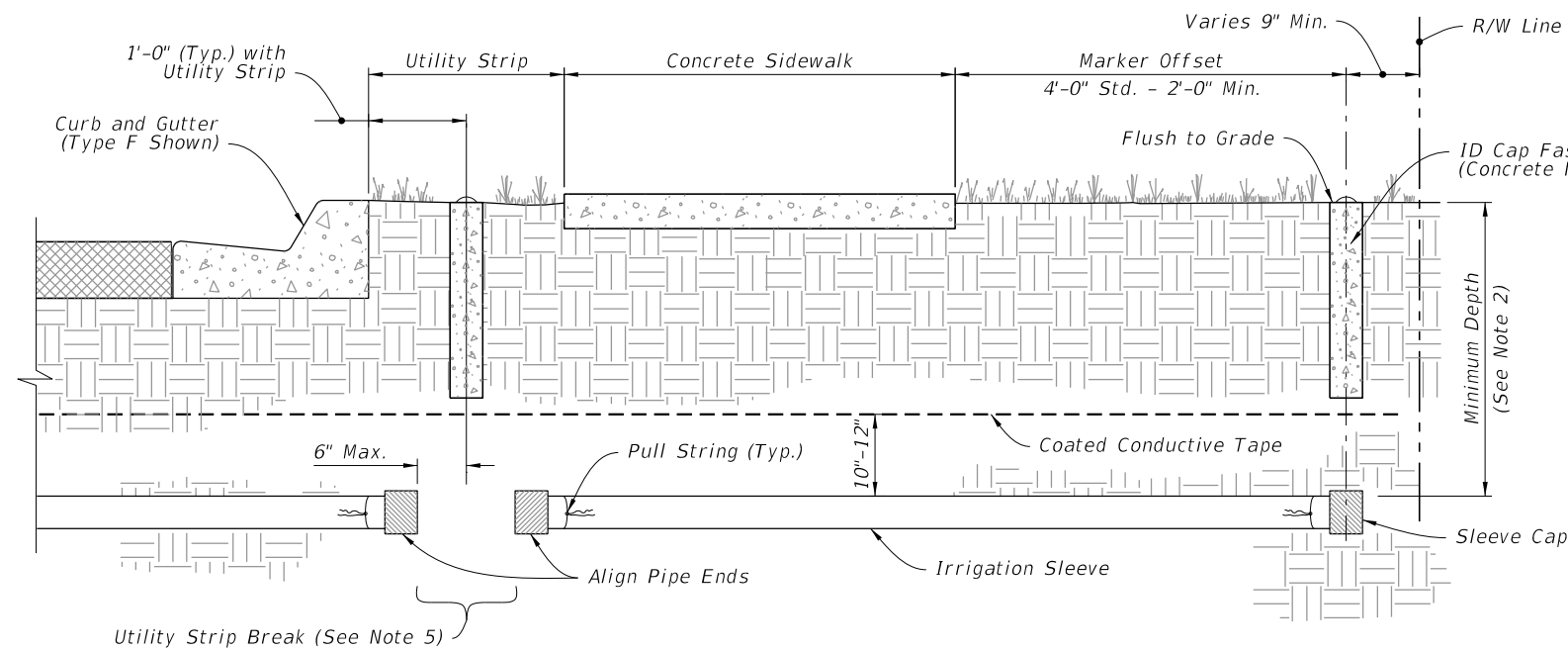

ROADWAY WITH UTILITY STRIP

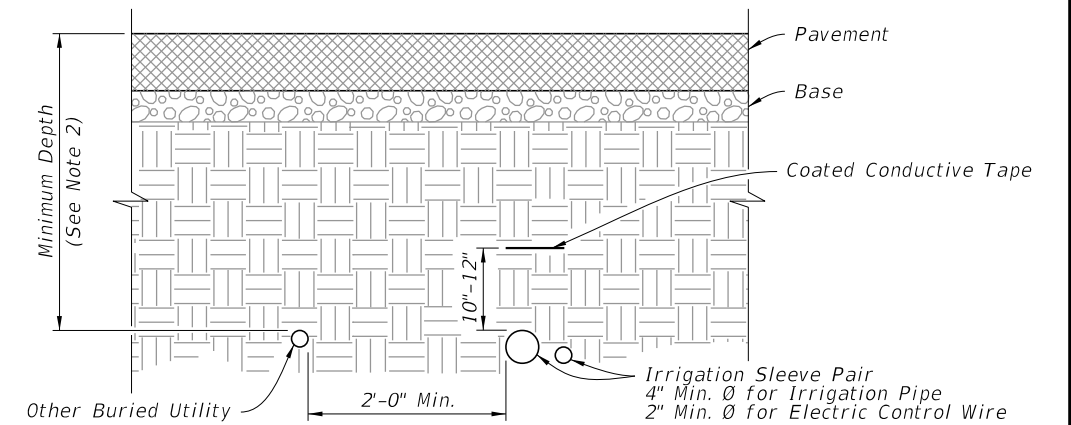

ROADWAY CROSS SECTION

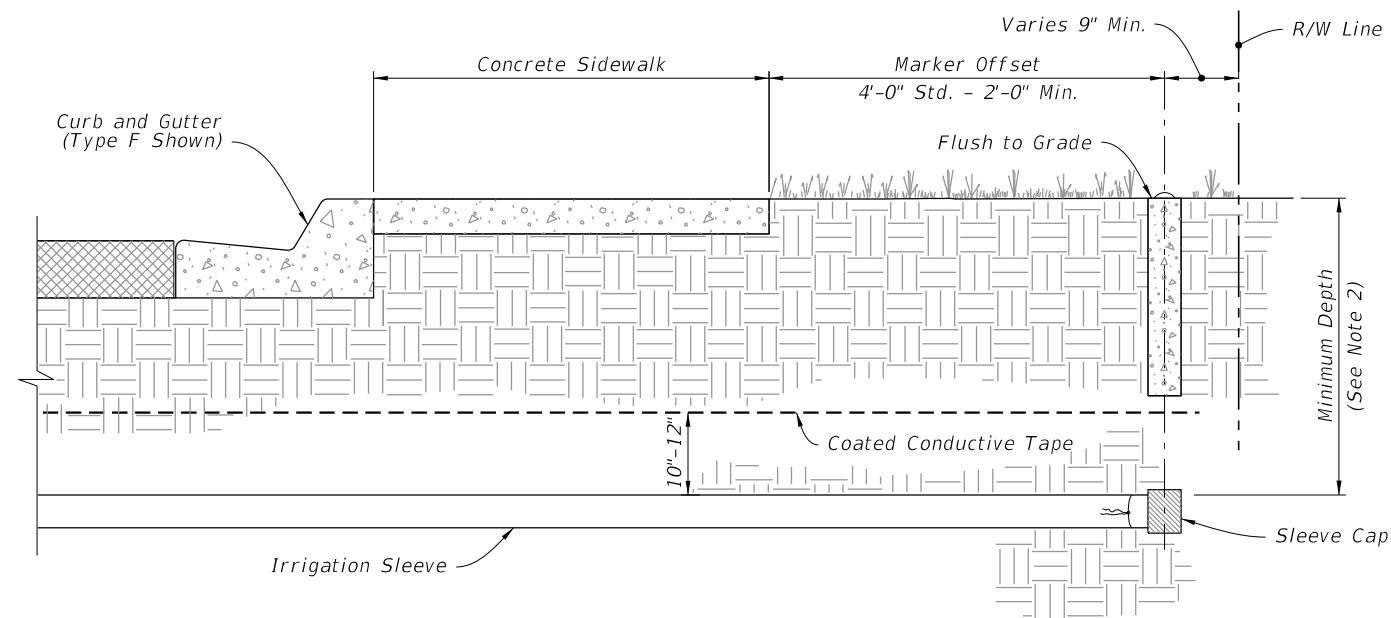

ROADWAY WITHOUT UTILITY STRIP

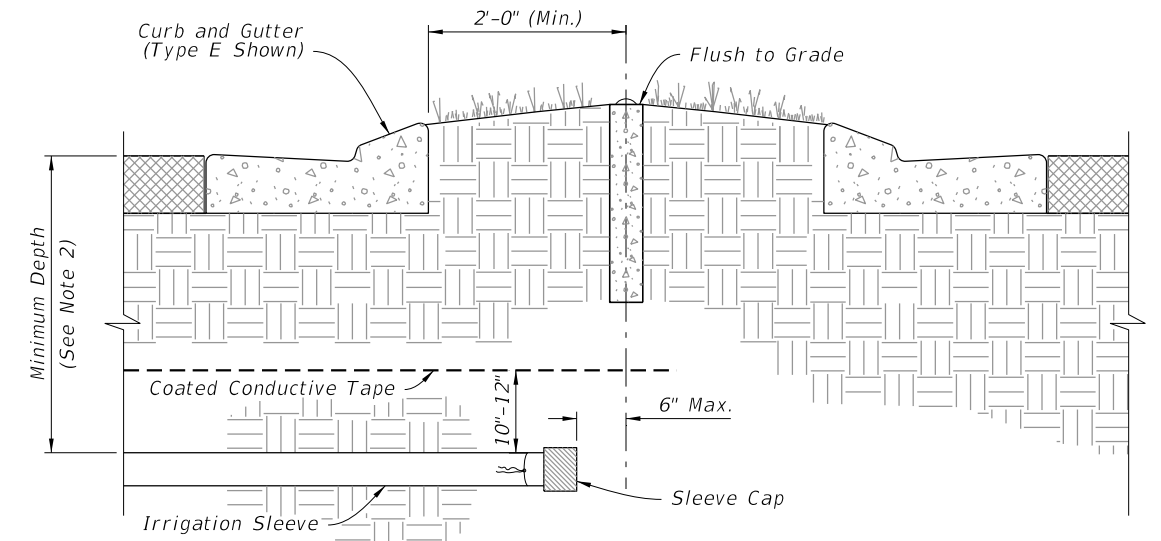

ROADWAY MEDIAN OR ROUNDABOUT

NOTES:

1. Work this Index with Specification 591.
2. Install Sleeve with the minimum depth measured from the top of the Irrigation Sleeve as shown in the Plans or specified in Index 630-001.
3. When installing Irrigation Sleeves in a median crossover, place sleeves along the centerline.
4. Irrigation Sleeves for Electrical Control Wire and Irrigation Pipe must be no further than 12" apart.
5. Install Utility Strip Breaks only when shown in the Plans.

10/20/2022 8:54:47 AM

LAST REVISION 11/01/19	REVISION	DESCRIPTION:		FY 2023-24 STANDARD PLANS	LANDSCAPE IRRIGATION SLEEVES	INDEX 591-001	SHEET 1 of 1
---------------------------	----------	--------------	---	------------------------------	------------------------------	------------------	-----------------