

GENERAL NOTES:

1. If the loop lead-in is 75' or less from the edge of the loop detector to controller cabinet, continue the twisted pair to the cabinet. If the loop lead-in is greater than 75' continue the twisted pair an Intermediate Pullbox, splice to shielded lead-in wire and continue to the controller cabinet.
2. Provide sufficient saw-cut width to allow unforced placement of loop wires or lead-in cables into the saw-cut. Except across expansion joints, saw-cut to a standard depth of 3", but no more than 4" below the top of the final surface.
3. On resurfacing or new roadway construction projects, install the loop wires and lead-in cables in the asphalt structural course prior to the placement of the asphalt friction course. Place the loop wires and lead-in cables in a saw cut in the structural course.
4. Use nonmetallic hold down material to secure loop wires and lead-ins to the bottom of saw-cuts. Place the hold down material approximately 12" intervals around loops and 24" intervals on lead-ins.
5. The minimum distance between the twisted pairs of loop lead-in wire is 6" from the loop to 12" from the pavement edge or curb.
6. Splice Connections in pull boxes with UL listed, watertight, insulated enclosures. Place one enclosure over the end of each conductor and place a third enclosure over the exposed end of the shielded cable. As an alternate, a larger diameter enclosure that will accommodate both the splices of the conductors and the exposed end of the shielded cable may be used.
7. Do not disturb more than a 6" x 6" area of asphalt. Restore asphalt as directed by the Engineer.
8. Alternative installations may be approved by the State Traffic Operations Engineer.

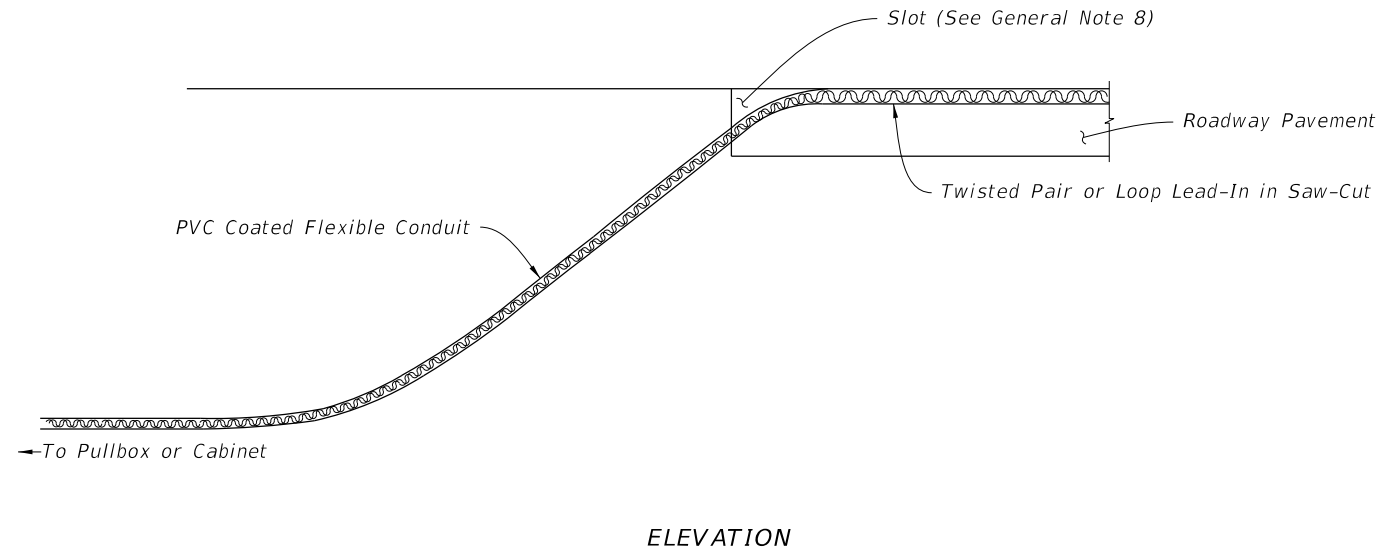
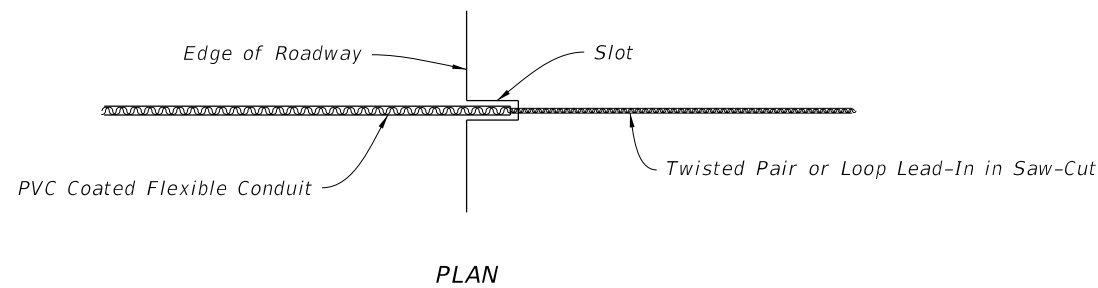

NOTES:

1. Cut a slot in the edge of the roadway of sufficient size and depth to snugly place the end of the flexible conduit.
2. Install the conduit at least 6" into the roadway pavement and approximately 2" below the top of the roadway surface.
3. The departure angle of the conduit from the roadway is between 30° to 45°.

INSTALLATION WITHOUT CURB & GUTTER

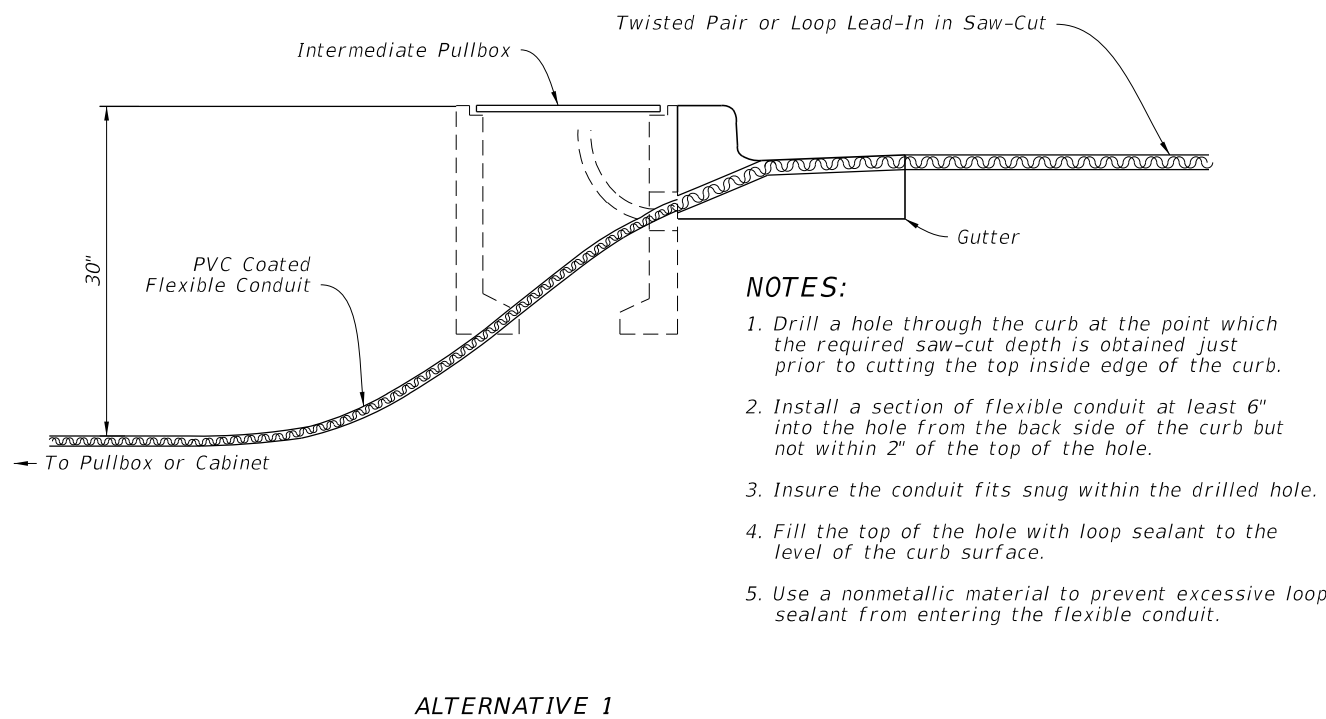

NOTES:

1. Drill a hole through the curb at the point which the required saw-cut depth is obtained just prior to cutting the top inside edge of the curb.
2. Install a section of flexible conduit at least 6" into the hole from the back side of the curb but not within 2" of the top of the hole.
3. Insure the conduit fits snug within the drilled hole.
4. Fill the top of the hole with loop sealant to the level of the curb surface.
5. Use a nonmetallic material to prevent excessive loop sealant from entering the flexible conduit.

ALTERNATIVE 1

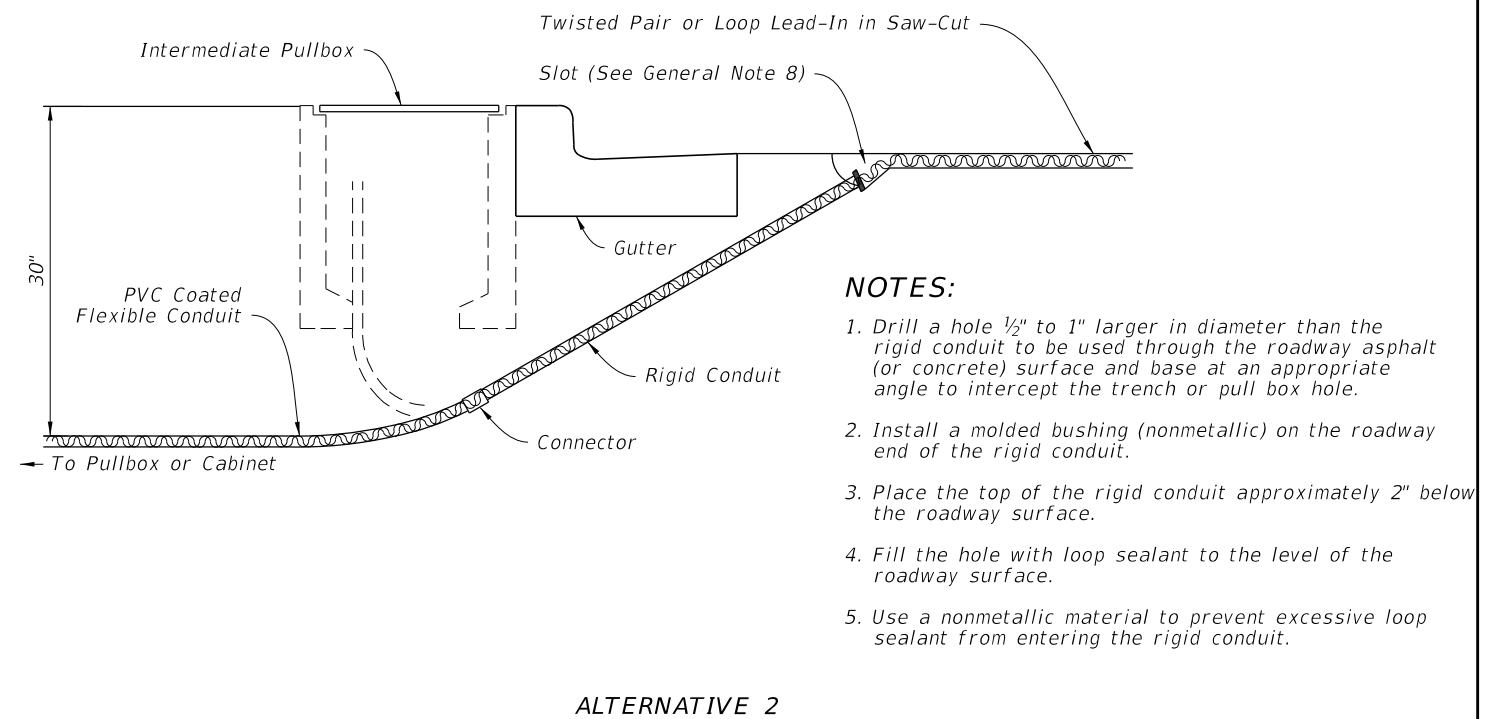

NOTES:

1. Drill a hole 1/2" to 1" larger in diameter than the rigid conduit to be used through the roadway asphalt (or concrete) surface and base at an appropriate angle to intercept the trench or pull box hole.
2. Install a molded bushing (nonmetallic) on the roadway end of the rigid conduit.
3. Place the top of the rigid conduit approximately 2" below the roadway surface.
4. Fill the hole with loop sealant to the level of the roadway surface.
5. Use a nonmetallic material to prevent excessive loop sealant from entering the rigid conduit.

ALTERNATIVE 2

INSTALLATION WITH CURB & GUTTER

TWISTED PAIR AND LOOP LEAD-IN INSTALLATION

10/6/2022 2:33:20 PM

LAST REVISION 11/01/18	DESCRIPTION:		FY 2023-24 STANDARD PLANS	VEHICLE LOOP INSTALLATION DETAILS	INDEX	SHEET
			660-001		1 of 2	

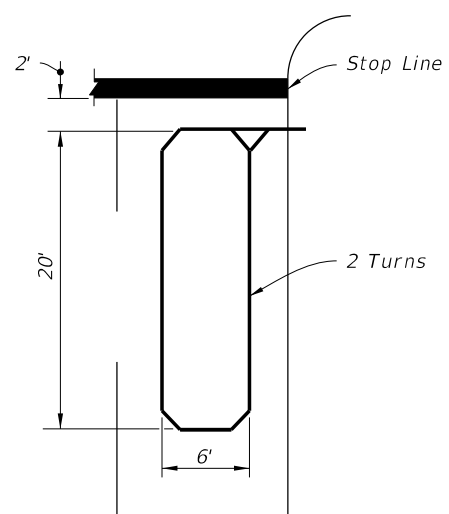

TYPE A

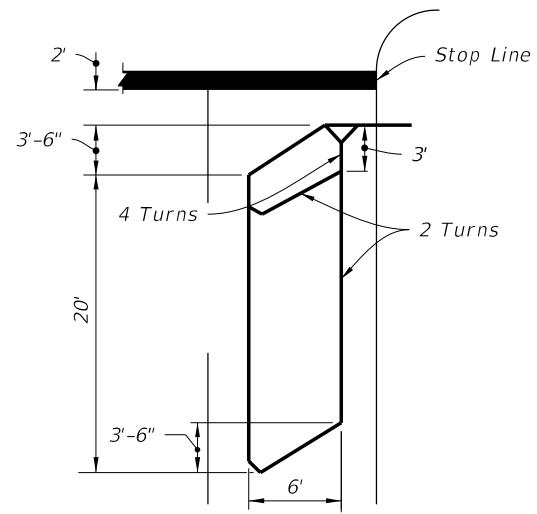

TYPE D

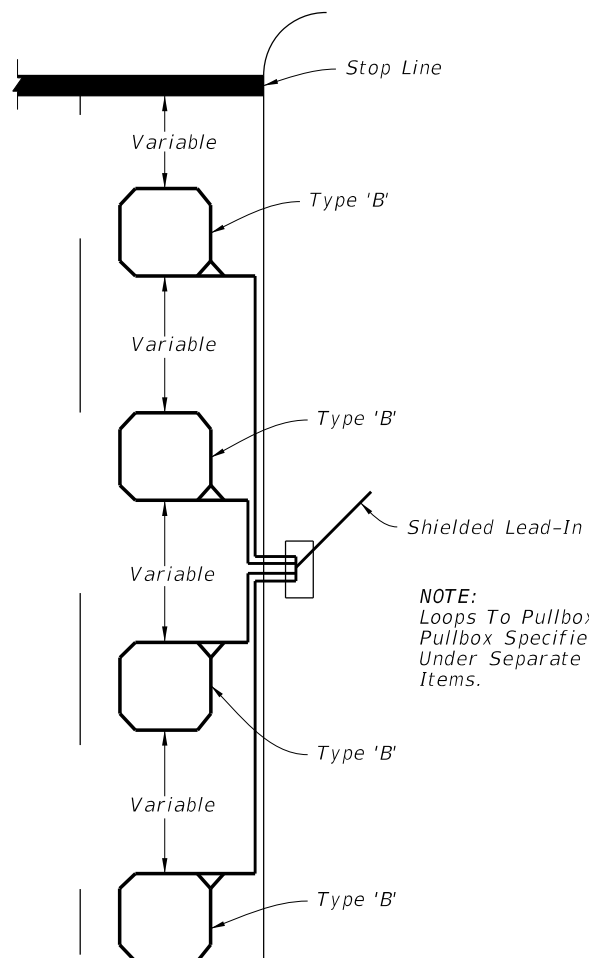

TYPE G

NOTE:
Loops To Pullbox.
Pullbox Specified
Under Separate Pay
Items.

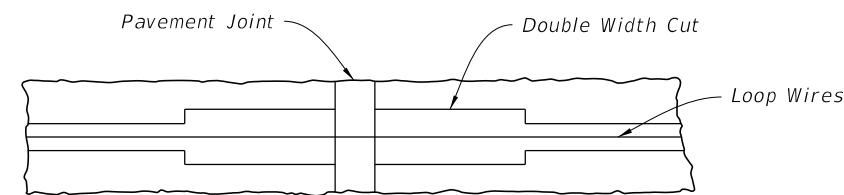

PLAN

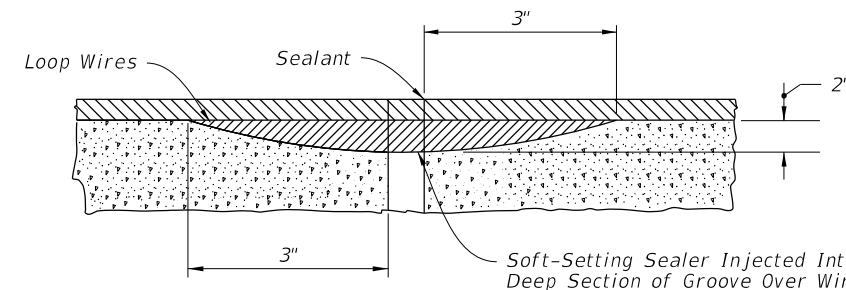

VERTICAL SECTION

CONCRETE PAVEMENT EXPANSION JOINTS

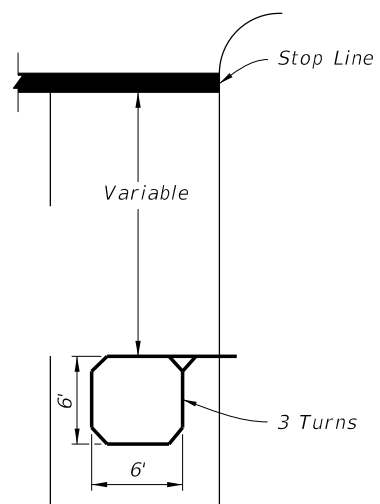

TYPE B

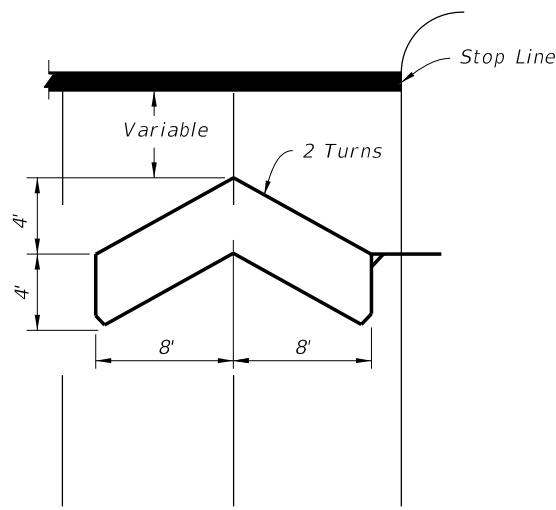

TYPE E

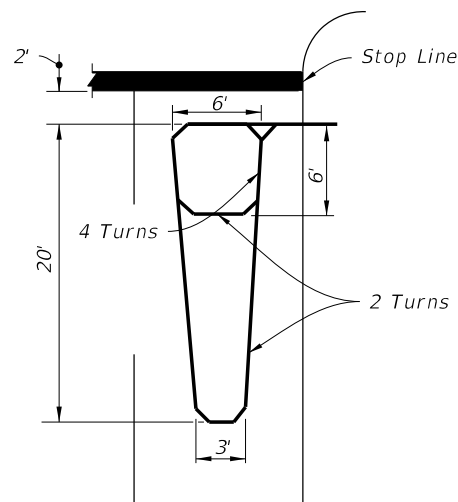

TYPE C

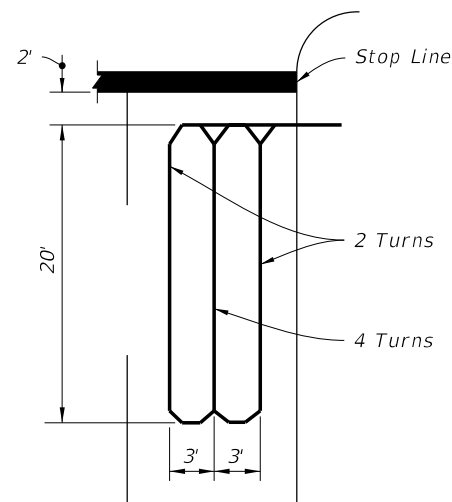

TYPE F

NOTE:
Loop conductors must follow saw-cut
to bottom forming slack section at joint.

NOTES:

1. The number of "Turns" indicated at the specified point on the loop refers to the number of passes of loop wires which are placed in the saw-cut forming the complete loop.
2. Loop types or details not drawn to scale.
3. Loop Types are centered in a single lane except Type E which is centered on two lanes.
4. The number of individual loops in the Type G loop may vary up to a maximum of four (4).
5. Lead-in may be connected to either end of loop.
6. When shown in the Plans, the leading edge of loop Types A, C, D, & F may extend past the stop line a maximum of 10' and the length of these loops may be extended to a maximum of 60'.
7. Do not install loop lead-in wires in the same pull box with signal power cable.

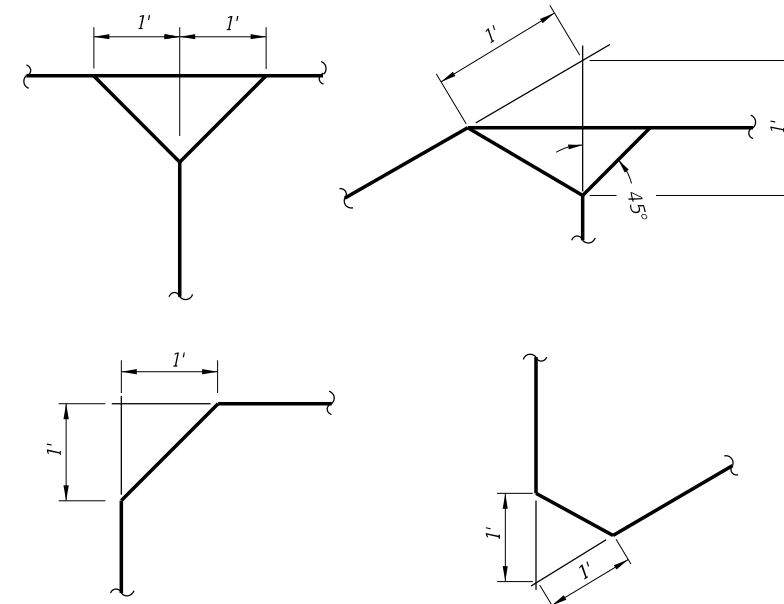

LOOP CORNER AND LEAD-IN DETAILS

LOOP TYPES

LOOP TYPES, EXPANSION JOINTS, AND DETAILS

10/6/2022 2:33:21 PM

LAST REVISION 11/01/18

DESCRIPTION:



FY 2023-24 STANDARD PLANS

VEHICLE LOOP INSTALLATION DETAILS

INDEX 660-001

SHEET 2 of 2