

GENERAL NOTES:

1. Shop Drawings: This Index is considered fully detailed, only submit shop drawings for minor modifications not detailed in the Plans.
2. Prior to Fabrication: Verify the installed foundation elevation will result in the required signal elevation and adjust the Pole height as needed.
3. Details for Signal and Sign locations, Signal Head attachment, Sign attachment, Pedestrian Head attachment, and Foundation Conduit are not shown for simplicity.
4. Materials:
 - A. Poles, Mast Arms and Backing Rings:
 - a. Less than 3/16": ASTM A1011 Grade 50, 55, 60 or 65
 - b. Greater than or equal to 3/16": ASTM A572 Grade 50, 55, 60 or 65
 - c. ASTM A595 Grade A (55 ksi yield) or Grade B (60 ksi yield)
 - B. Steel Plates: ASTM A36
 - C. Weld Metal: E70XX
 - D. Bolts, Nuts and Washers:
 - a. High Strength Hex Head Bolts: ASTM F3125, Grade A325, Type 1
 - b. Nuts: ASTM A563 DH Heavy-Hex
 - c. Washers: ASTM F436 Type 1, one under turned element
 - E. Anchor Bolts, Nuts and Washers:
 - a. Anchor Bolts: ASTM F1554 Grade 55
 - b. Nuts: ASTM A563 Grade A Heavy-Hex (5 per anchor bolt)
 - c. Plate Washers: ASTM A36 (2 per bolt)
 - F. Threaded Bars/Studs: ASTM A36 or ASTM A307
 - G. Handhole Frame: ASTM A709 or ASTM A36, Grade 36
 - H. Handhole Cover: ASTM A1011 Grade 50, 55, 60 or 65
 - I. Pole Caps and Nut Covers: Fabricate from cast aluminum or galvanized carbon steel.
 - J. Stainless Steel Screws: AISI Type 316
 - K. Concrete: Class IV (Drilled Shaft) for all environmental classifications.
 - L. Reinforcing Steel: Specification 415
5. Fabrication:
 - A. Welding:
 - a. Specification 460-6.4 and
 - b. AASHTO LRFD Specification for Structural Supports for Highway Signs, Luminaires, and Traffic Signals Section 14.4.4
 - B. Poles and Mast Arms:
 - a. Round or 12-sided (Min.)
 - b. Taper pole diameter at 0.14 inches per foot
 - c. Upright poles must be a single section. For arms and upright poles, circumferential welds and laminated sections are not permitted.
 - d. Arms may be either one or two sections. See Sheet 4 for telescopic splice detail
 - e. Fabricate longitudinal seam welds with 60 percent minimum penetration or fusion welds except:
 1. Use a full-penetration groove weld within 6 inches of the circumferential tube-to-plate connection.
 2. Use full-penetration groove welds on the female end section of telescopic (i.e., slip type) field splices for a minimum length of one and one-half times the inside diameter of the female section plus 6 inches.
 - f. Locate longitudinal seams weld along the:
 1. Lower quadrant of the arms.
 2. Same side of the pole as the arm connections
 - g. Face handhole perpendicular from arm on single arm poles, perpendicular from the first arm of double arms poles facing away from traffic or see special instructions on the Mast Arm Tabulation Sheet.
 - h. Provide a 'J' or 'C' hook at the top of the pole for signal wiring support (See Sheet 6)
 - i. First and Second arm camber angle = 2'
 - j. Bolt holes diameters as follows:
 1. Bolts (except Anchor bolts): Bolt diameter plus 1/16" prior to galvanizing.
 2. Anchor Bolts: Bolt diameter plus 1/2" (Max.).
 - C. Coatings:
 - A. All Nuts, Bolts, Washers and Threaded Bars/Studs: ASTM F2329
 - B. All other steel items including plate washers ASTM A123
 7. Construction:
 - A. Foundation: Specification 455 Drilled Shaft, except that payment is included in the cost of the Mast Arm.
 - B. Install Pole vertically.
 - C. Place structural grout pad with drain between top of foundation and bottom of baseplate in accordance with Specification 649-7.
 - D. Attach Sign Panels and Signals centered on the elevation of the Mast Arm.
 - E. Wire Access holes are 1 1/2" or less in diameter.

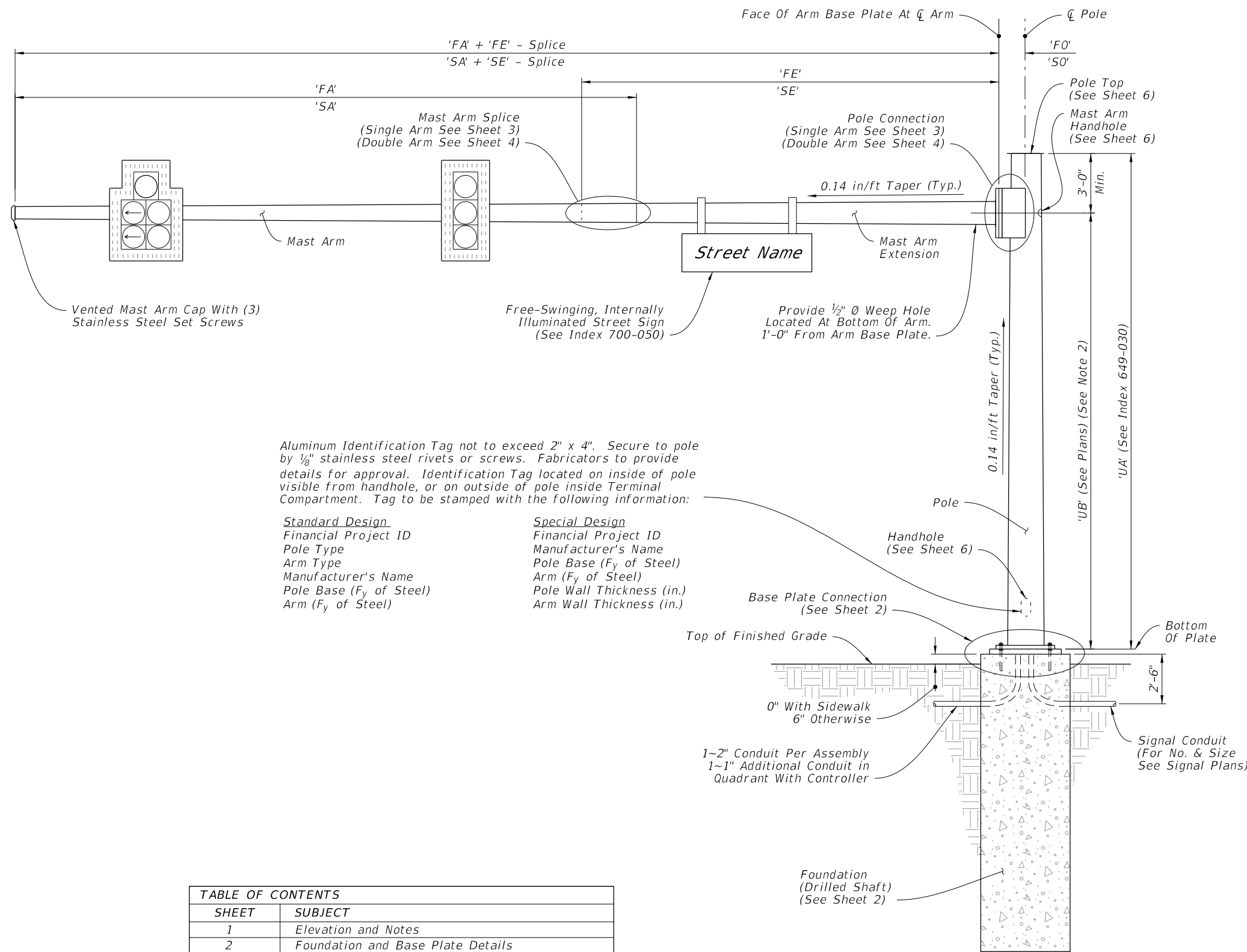

Aluminum Identification Tag not to exceed 2" x 4". Secure to pole by 1/8" stainless steel rivets or screws. Fabricators to provide details for approval. Identification Tag located on inside of pole visible from handhole, or on outside of pole inside Terminal Compartment. Tag to be stamped with the following information:

Standard Design	Special Design
Financial Project ID	Financial Project ID
Pole Type	Manufacturer's Name
Arm Type	Pole Base (F _y of Steel)
Manufacturer's Name	Arm (F _y of Steel)
Pole Base (F _y of Steel)	Pole Wall Thickness (in.)
Arm (F _y of Steel)	Arm Wall Thickness (in.)

TABLE OF CONTENTS	
SHEET	SUBJECT
1	Elevation and Notes
2	Foundation and Base Plate Details
3	Single Arm Connection and Splice Details
4	Double Arm Connection and Splice Details
5	Luminaire Arm and Connection Details
6	Handhole and Pole Top Details

Single Arm Shown, Double Arm Similar
(Luminaire Arm Not Shown)

MAST ARM ASSEMBLY

ELEVATION AND NOTES

10/16/2022 2:32:02 PM

LAST REVISION	DESCRIPTION:
11/01/21	



FY 2023-24
STANDARD PLANS

MAST ARM ASSEMBLIES

INDEX	SHEET
649-031	1 of 6

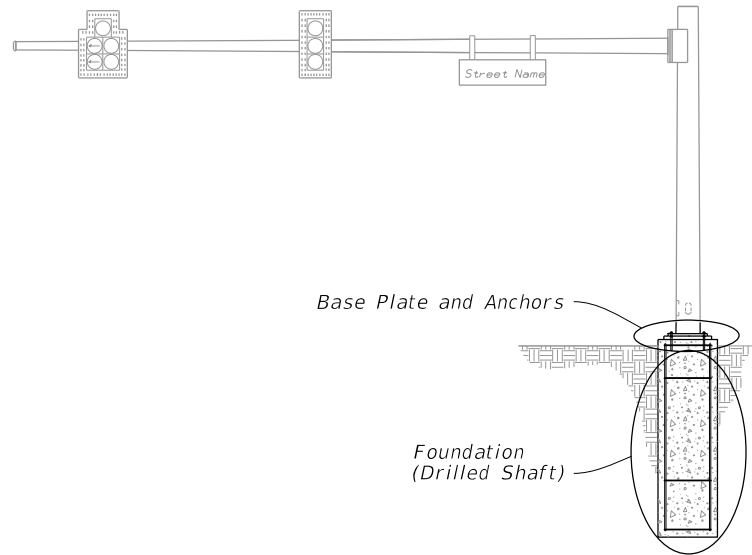

MAST ARM ASSEMBLY

NOTES:

1. The Structural Grout Pad diameter may be reduced where the footprint of the Grout Pad does not provide adequate clearance for the sidewalk and/or accessibility considerations.
2. See Index 649-030 and the plans for actual quantity of bolts in the Base Plate Connection.
3. The bottom hex nut of the Double Nuts shown in Section A-A may be substituted by a half-height anchor 'jam' nut. Provide individual nut covers (not shown) for each bolt.
4. Detail 'A' Silicone Caulk may be applied after installation. Consult with Manufacturer to determine the suitability of the caulk to be applied.

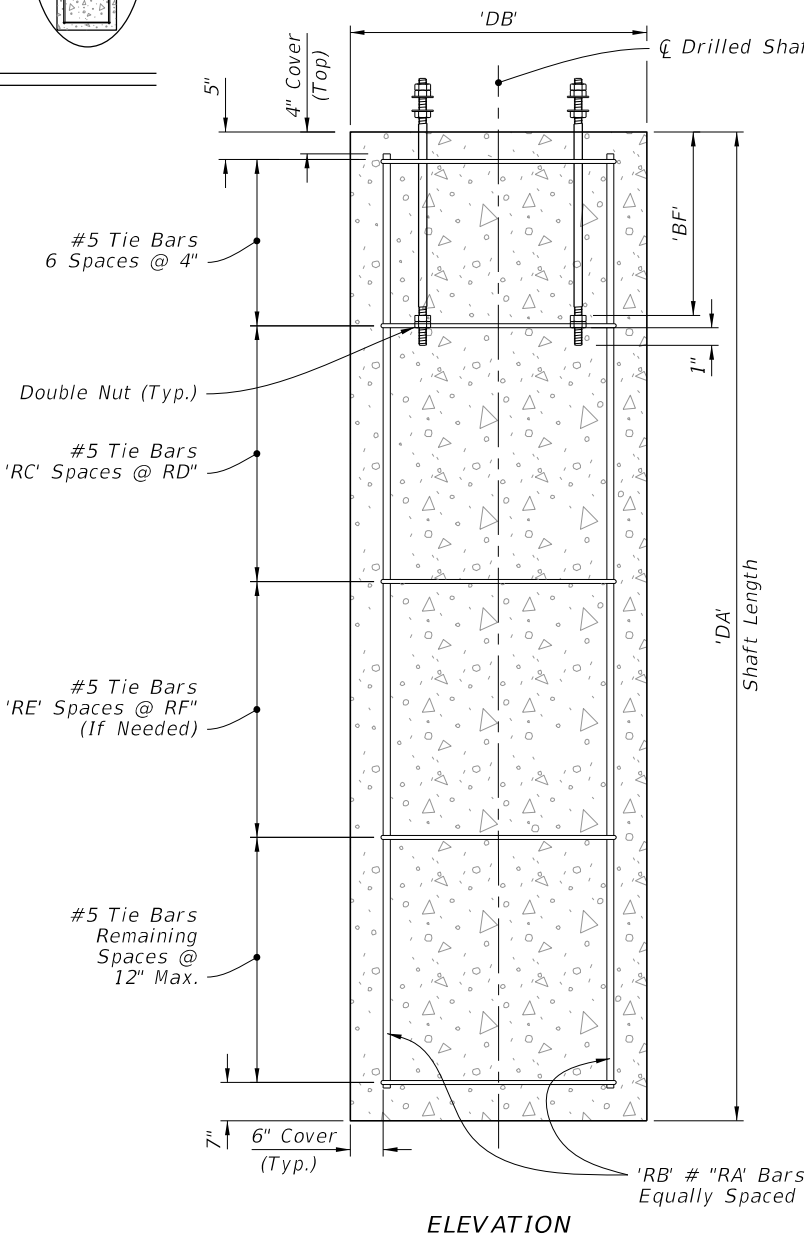
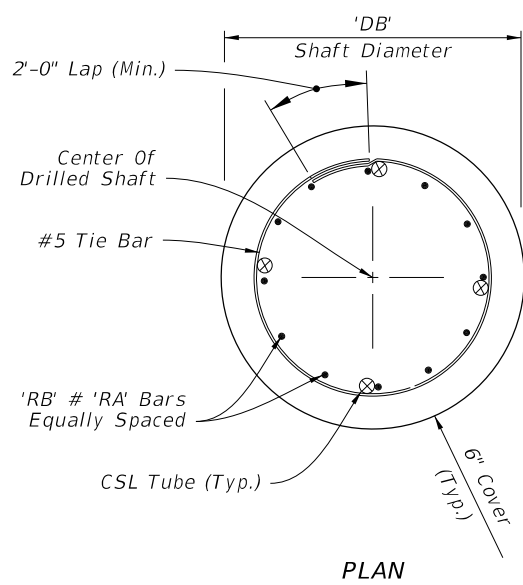

FOUNDATION

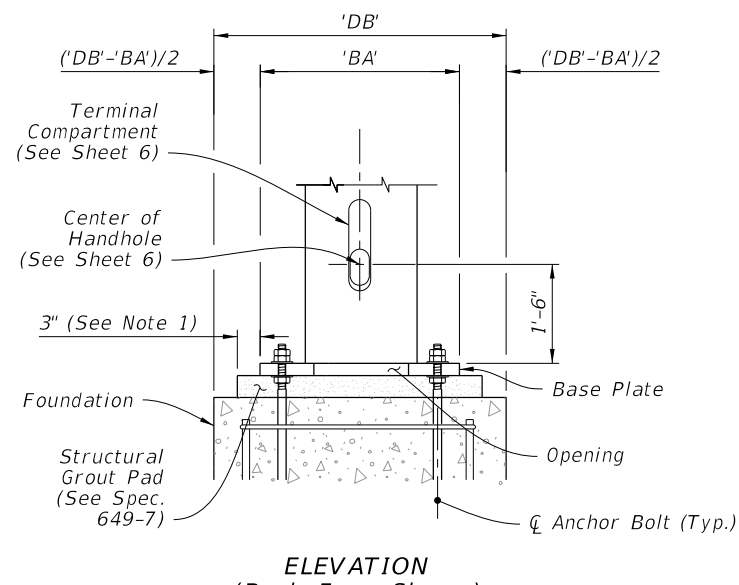
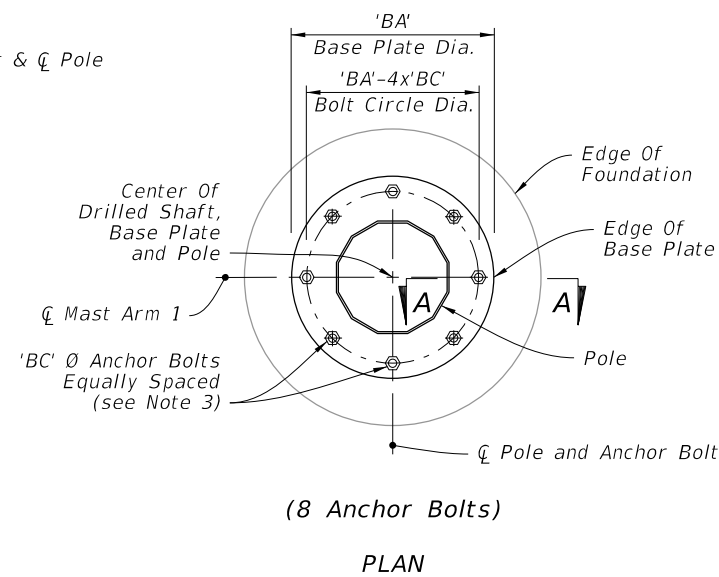
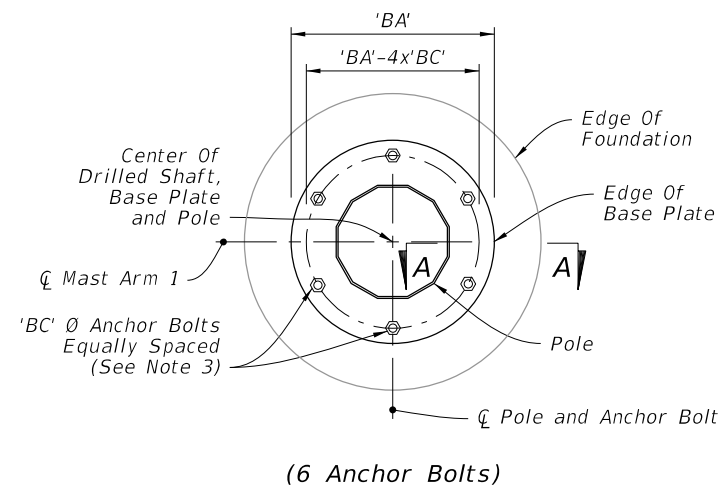

BASE PLATE CONNECTION

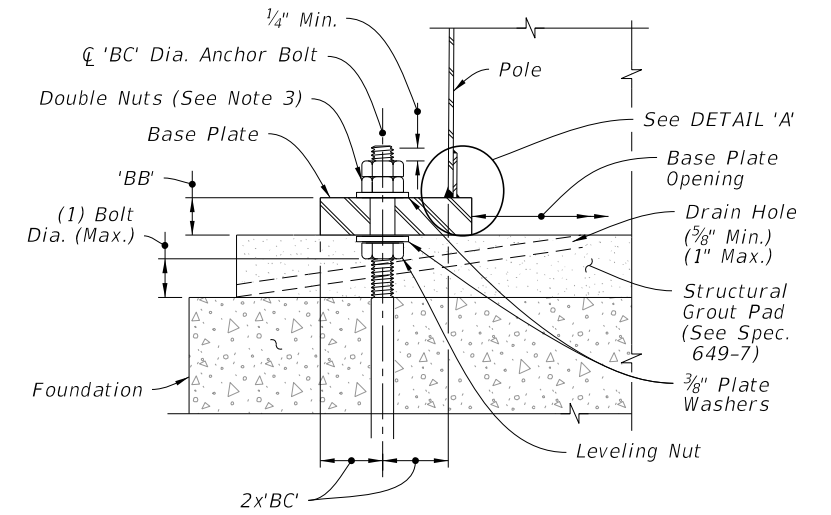

SECTION A-A

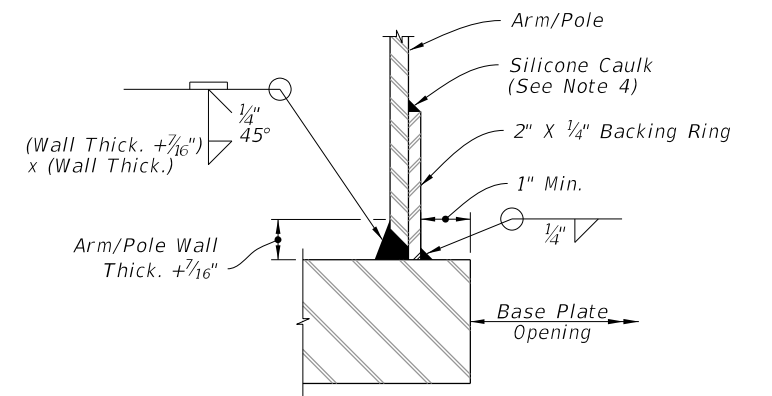

JOINT WELD DETAIL

DETAIL 'A'

FOUNDATION AND BASE PLATE DETAILS

10/6/2022 2:32:03 PM

LAST REVISION 11/01/21	DESCRIPTION:
---------------------------	--------------



FY 2023-24
STANDARD PLANS

MAST ARM ASSEMBLIES

INDEX
649-031

SHEET
2 of 6

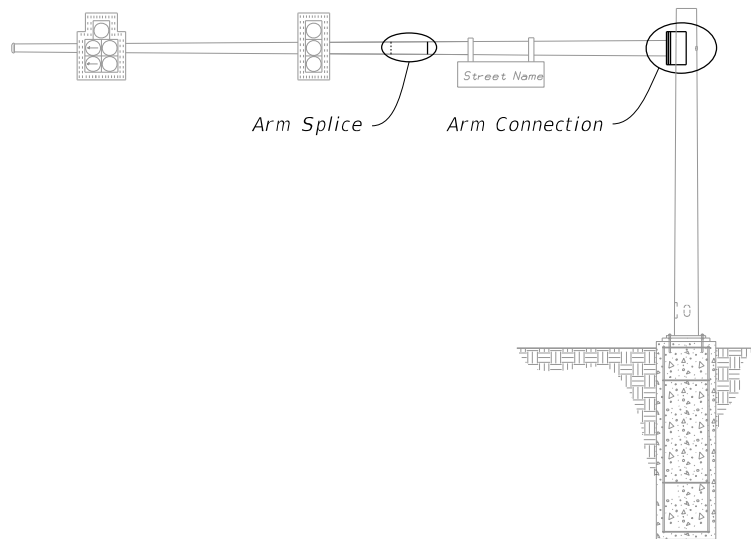

MAST ARM ASSEMBLY

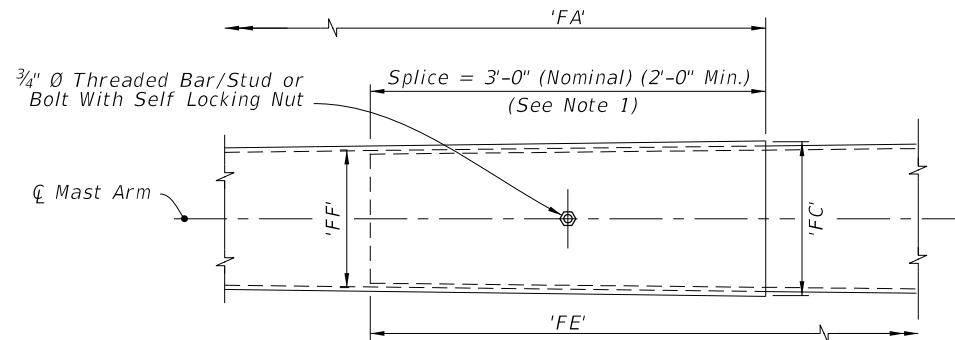

ARM SPLICE

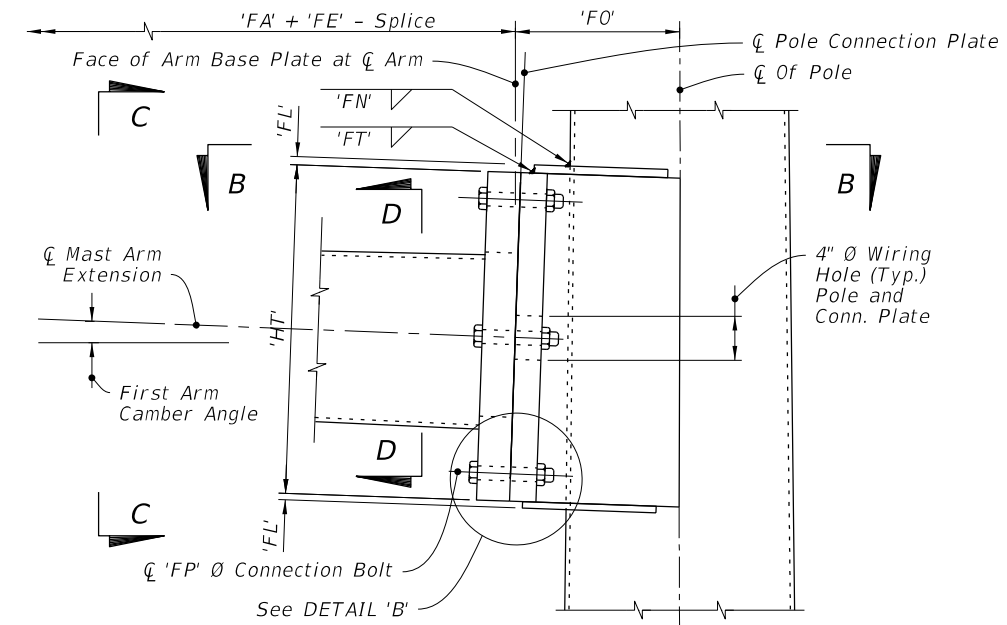

SINGLE ARM CONNECTION

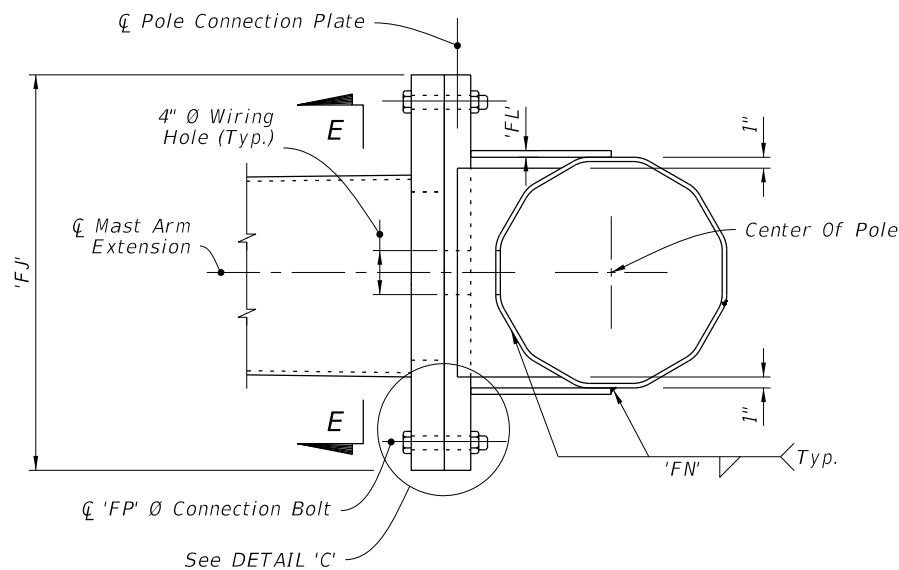

SECTION B-B

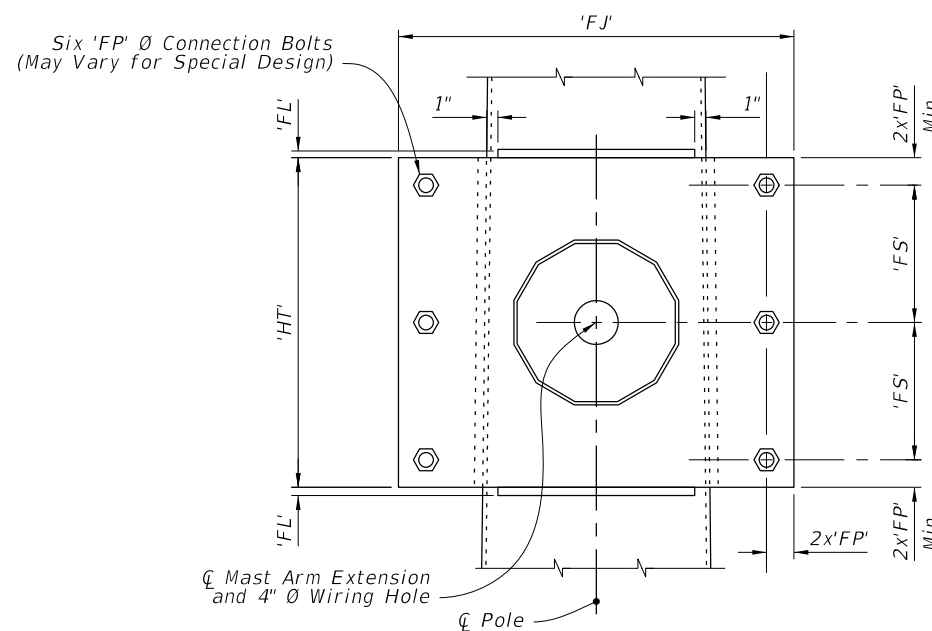

SECTION C-C

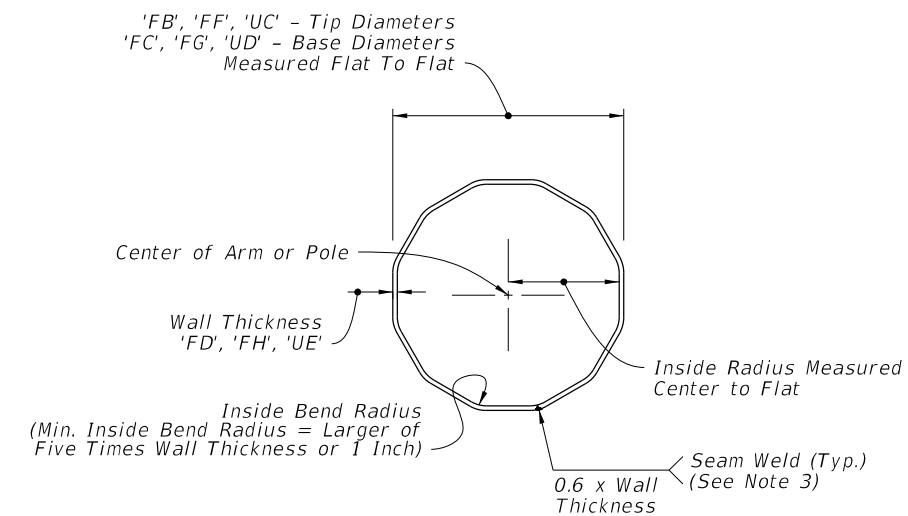

SECTION D-D

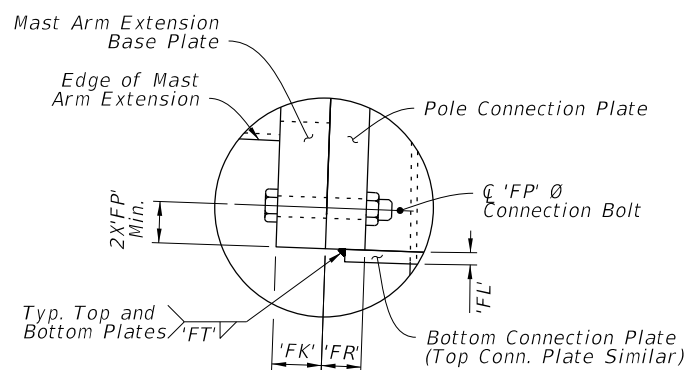

DETAIL 'B'

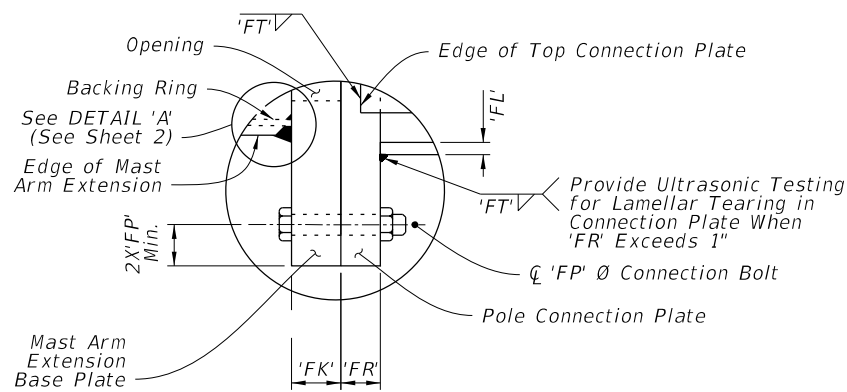

DETAIL 'C'

NOTES:

1. Install the 'Slip Joint' splice with a tight fit and no change in the Mast Arm taper due to the splice.
2. Details shown on this sheet are for 12 sided pole sections. However, sections with more than 12 sides and round sections are permitted provided outside diameter and wall thickness are not reduced.
3. Match mark the Arm and Connection Plates to ensure proper assembly and the seam weld is in the proper location (seam located at the bottom side of the Arm).

SINGLE ARM CONNECTIONS & SPLICE DETAILS

10/6/2022 2:32:04 PM

LAST REVISION 11/01/21	REVISION	DESCRIPTION:
---------------------------	----------	--------------



FY 2023-24
STANDARD PLANS

MAST ARM ASSEMBLIES

INDEX
649-031

SHEET
3 of 6

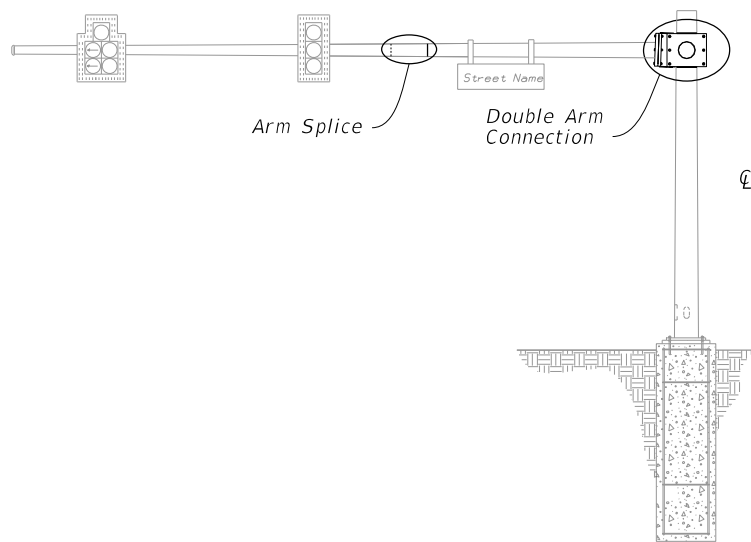

MAST ARM ASSEMBLY

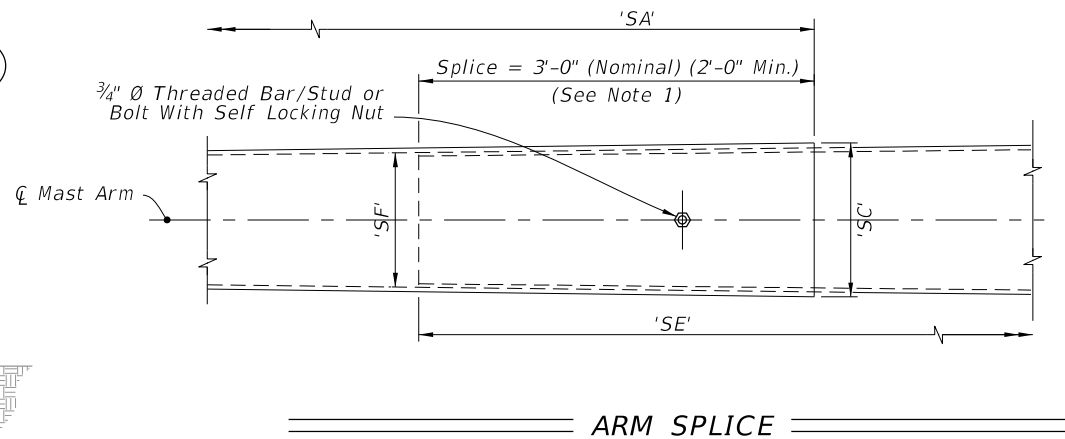

ARM SPLICE

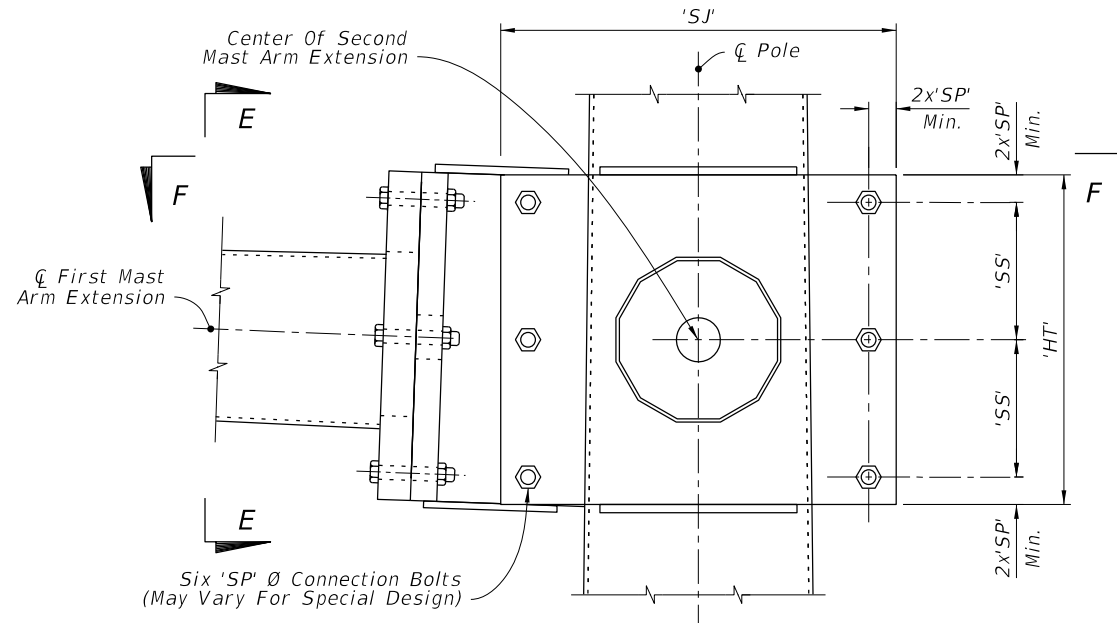

DOUBLE ARM CONNECTION

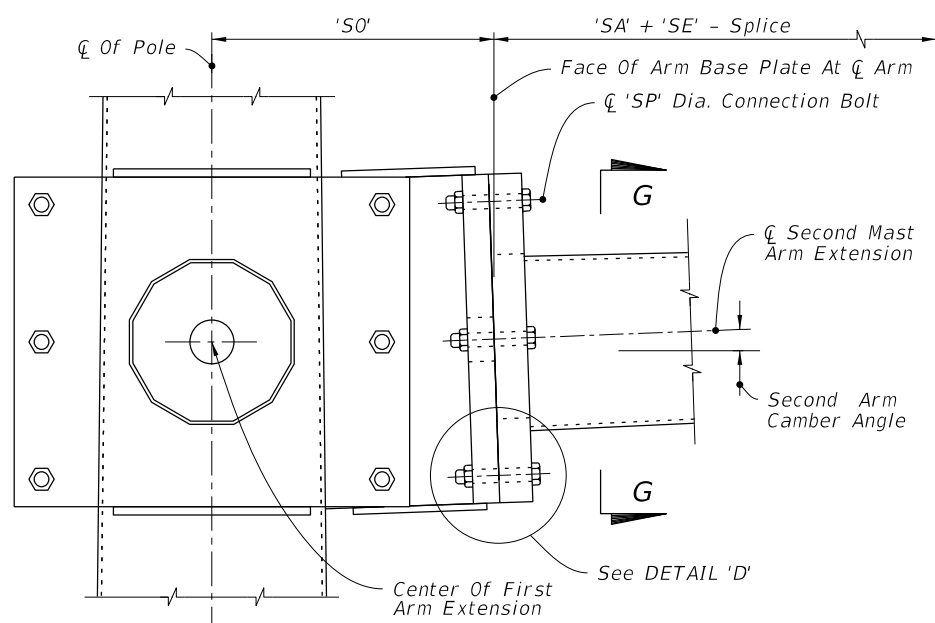

SECTION E-E

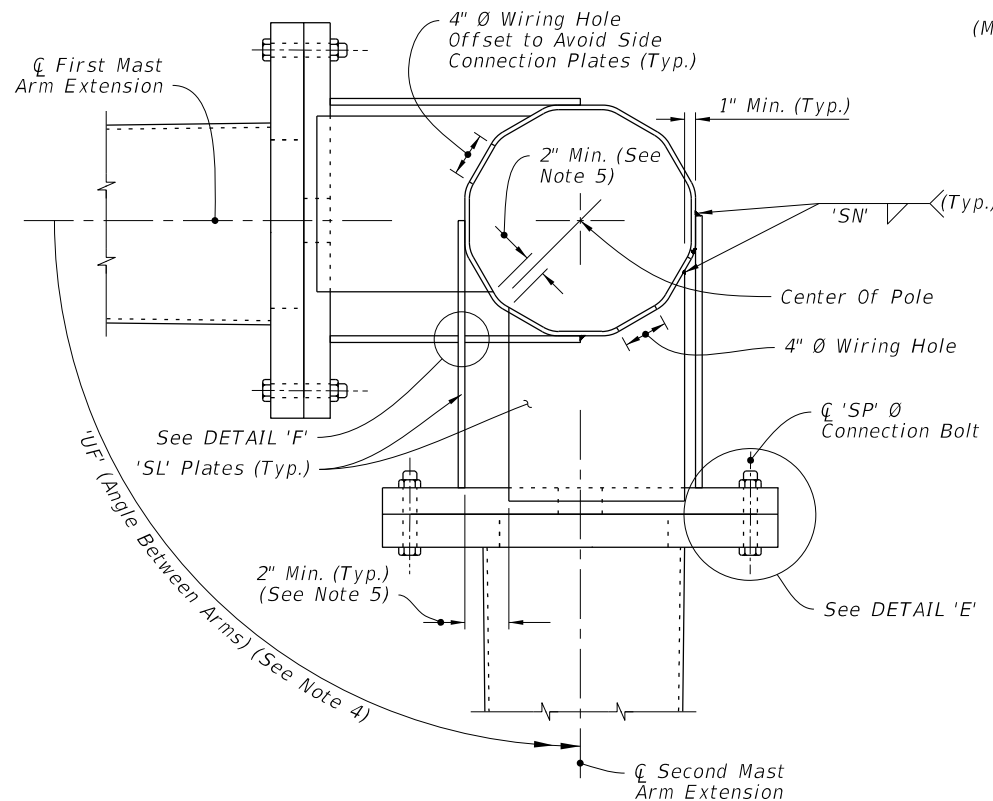

SECTION F-F

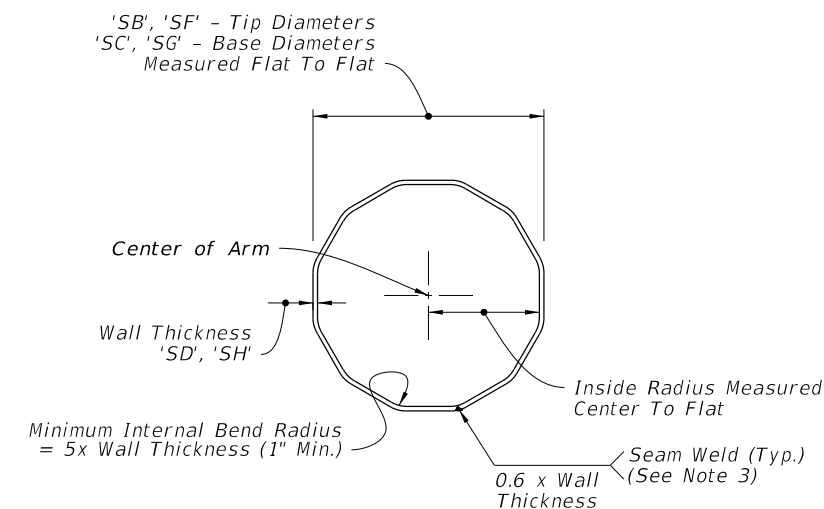

SECTION G-G

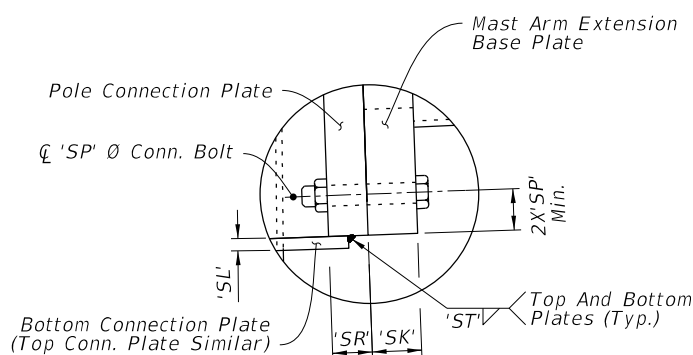

DETAIL 'D'

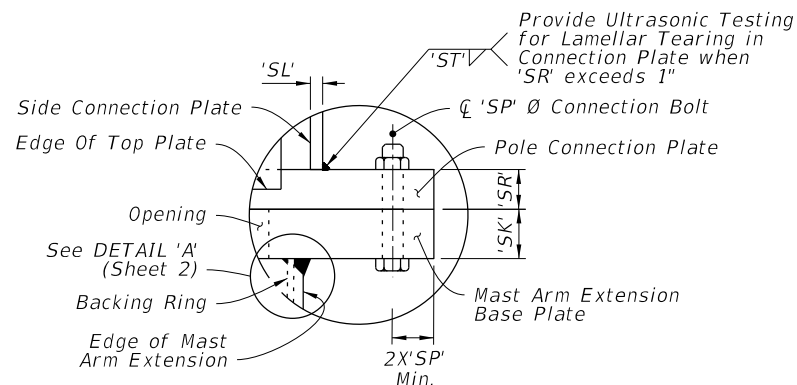

DETAIL 'E'

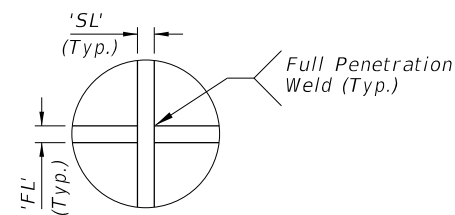

DETAIL 'F'

NOTES:

1. Install the 'Slip Joint' splice with a tight fit and no change in the Mast Arm taper due to the splice.
2. Details shown on this sheet are for 12 sided pole sections. However, sections with more than 12 sides and round sections are permitted provided outside diameter and wall thickness are not reduced.
3. Match mark the Arm and Connection Plates to ensure proper assembly and the seam weld is in the proper location (seam located at the bottom side of the Arm).
4. 'UF' measured counter clockwise from C First Mast Arm Extension.
5. Adjust width of top and bottom Connection Plates to maintain minimum clearance shown.

DOUBLE ARM CONNECTIONS & SPLICE DETAILS

10/6/2022 2:32:05 PM

LAST REVISION	DESCRIPTION:
11/01/21	



FY 2023-24
STANDARD PLANS

MAST ARM ASSEMBLIES

INDEX
649-031

SHEET
4 of 6

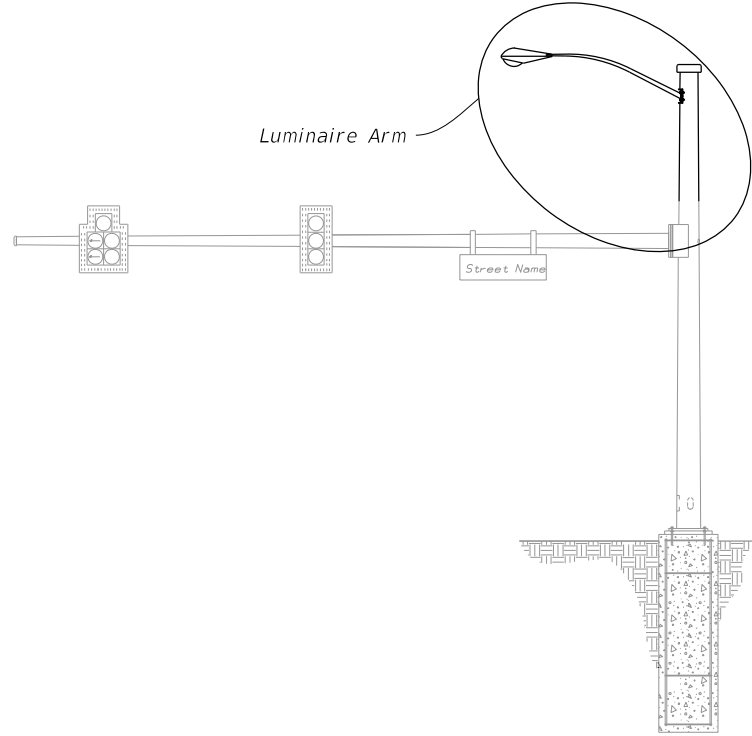

MAST ARM ASSEMBLY

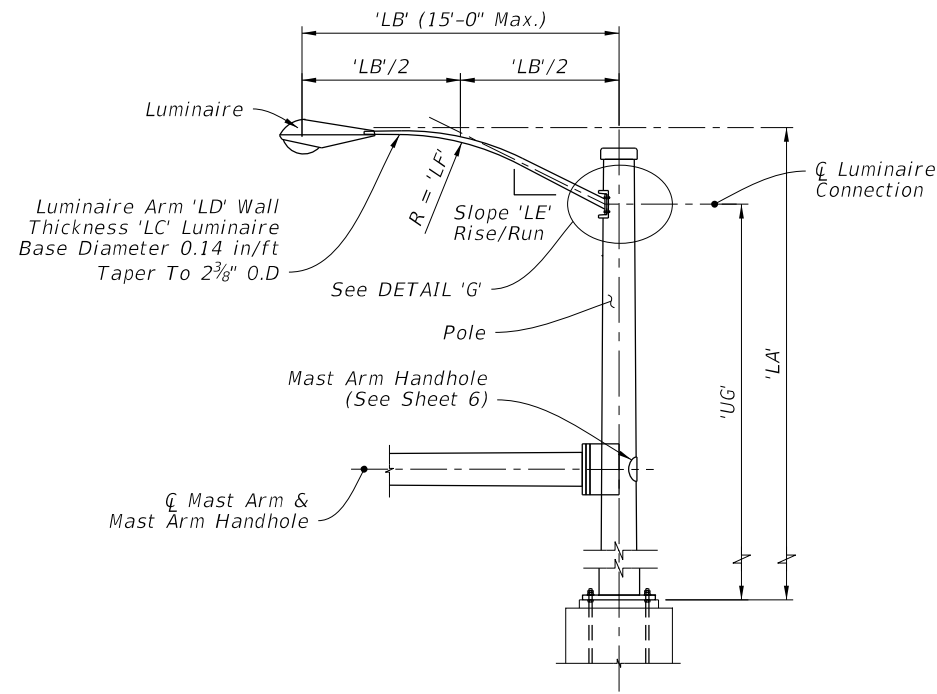

LUMINAIRE ELEVATION

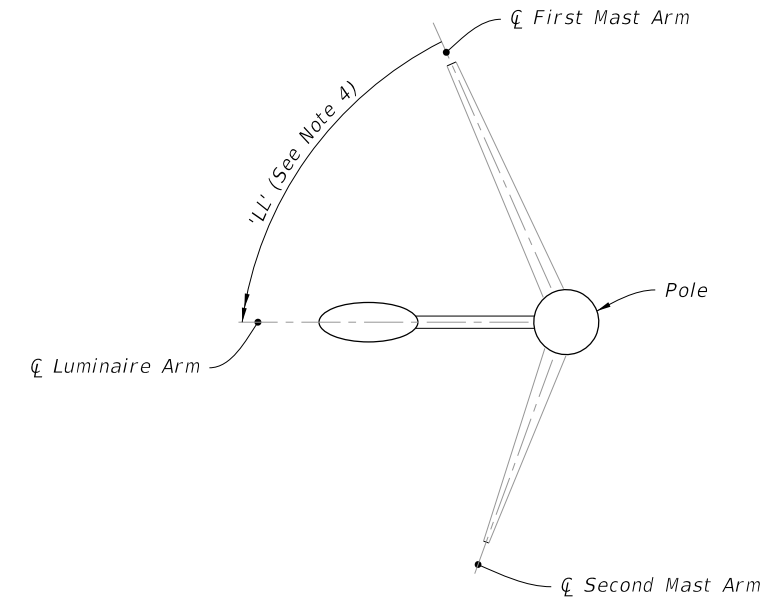

LUMINAIRE ORIENTATION

NOTES:

- Galvanized steel luminaire type and luminaire length may be found in the Lighting Plans.
- Align Luminaire Arm with Single Mast Arm or First Arm of Double Mast Arm unless indicated otherwise in the plans.
- The fabricator may substitute a 1/2" thick bent plate with the same flange width, height, and length as the MC 10x33.6 Channel section.
- 'LL' measure counter clockwise from First Mast Arm.

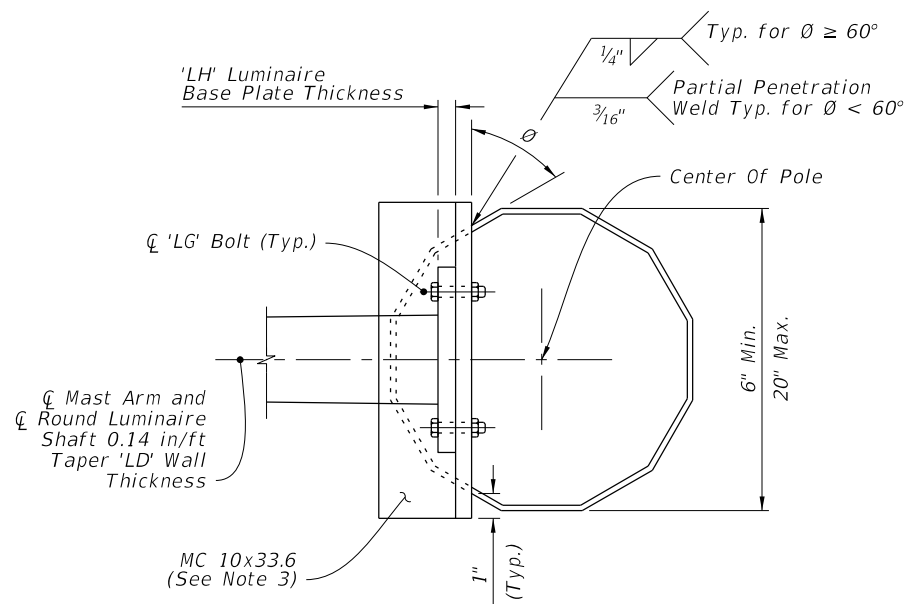

SECTION H-H

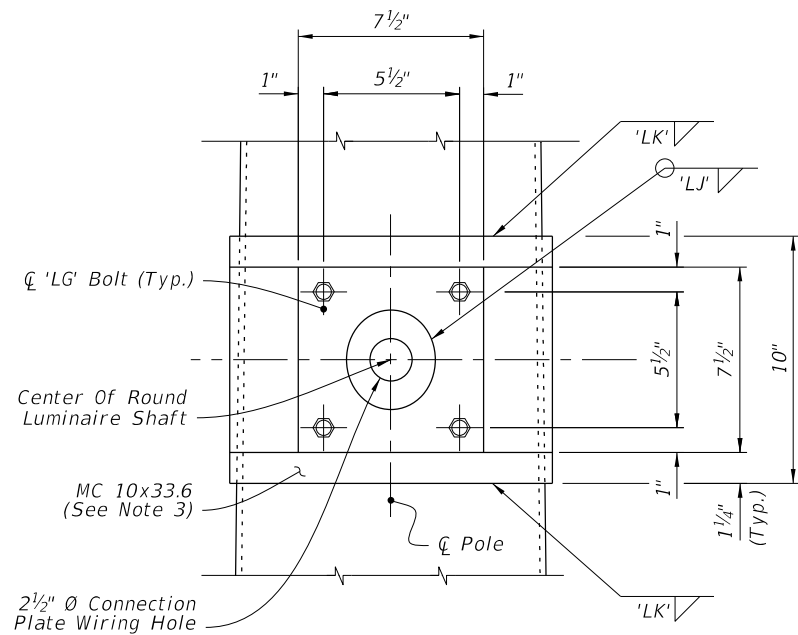

SECTION I-I

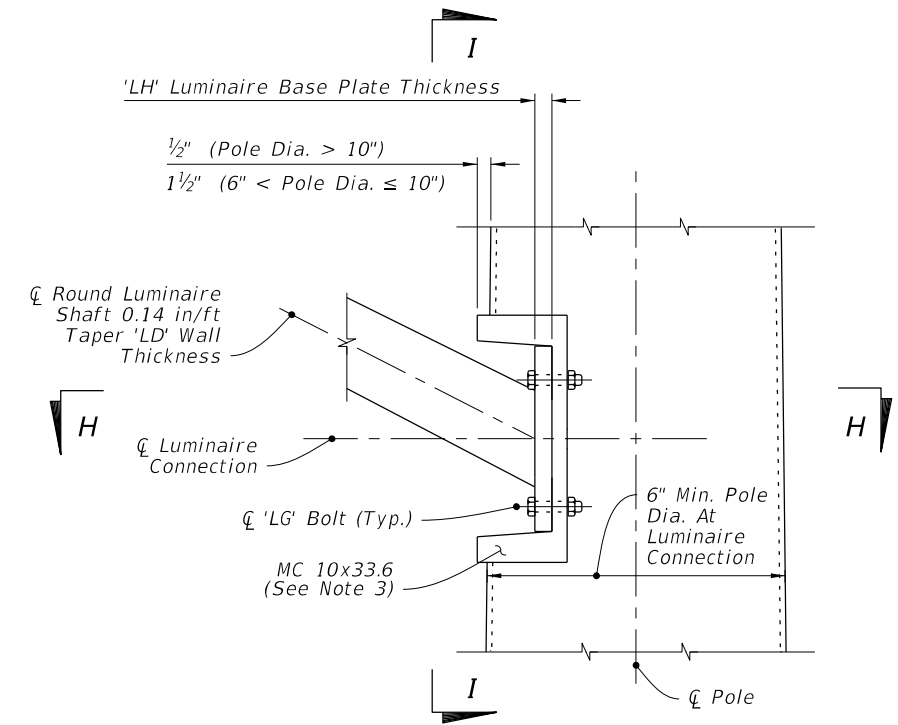

LUMINAIRE CONNECTION ELEVATION

DETAIL 'G'
LUMINAIRE ARM AND CONNECTION DETAILS

10/6/2022 2:32:06 PM

LAST REVISION 11/01/19	REVISION	DESCRIPTION:		FY 2023-24 STANDARD PLANS	MAST ARM ASSEMBLIES	INDEX 649-031	SHEET 5 of 6
---------------------------	----------	--------------	--	------------------------------	---------------------	------------------	-----------------

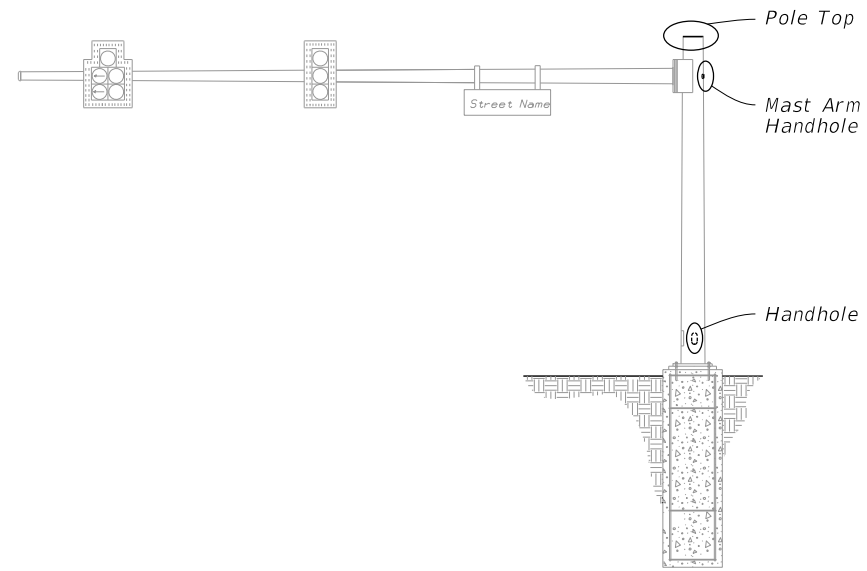

NOTES:

1. Handhole covers may be omitted when Terminal Compartment is provided.
2. See Mast Arm Tabulation sheet to see if Terminal Compartment is required and for locations.
3. Terminal Compartment Frame Height 2'-0" minimum to 2'-6" maximum. Align bottom of Terminal Compartment a minimum of 1" below the bottom of the Handhole Frame.
4. Any combination of Option 'a' or 'b' may be used, provided both lifting and wiring is accommodated. Cap may be flat plate or domed cap with set screws.
5. An alternate terminal compartment frame detail is allowed where the compartment frame is of constant depth and cuts into the pole at the frame top and bottom but lays flush with the pole on the frame sides. The frame is then welded to the pole using fillet welds all around the outside.

MAST ARM ASSEMBLY

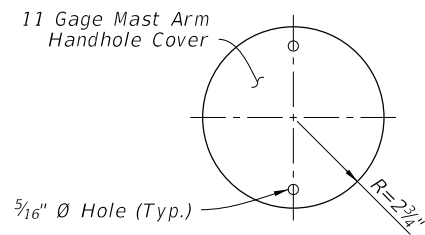

COVER

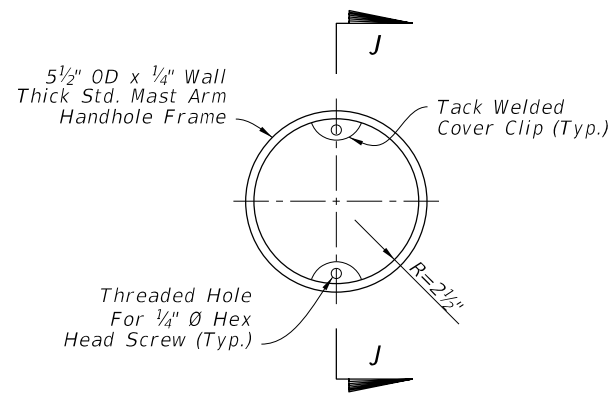

FRAME

MAST ARM HANDHOLE

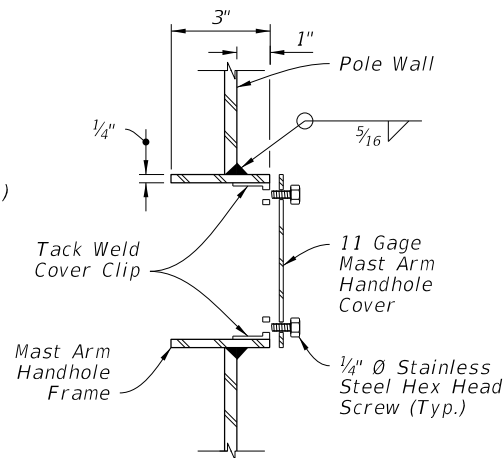

SECTION J-J

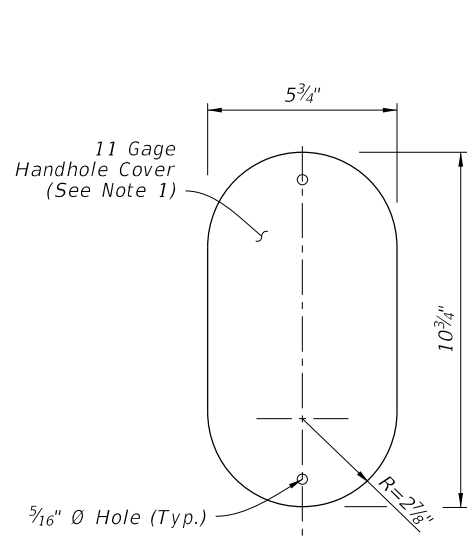

COVER

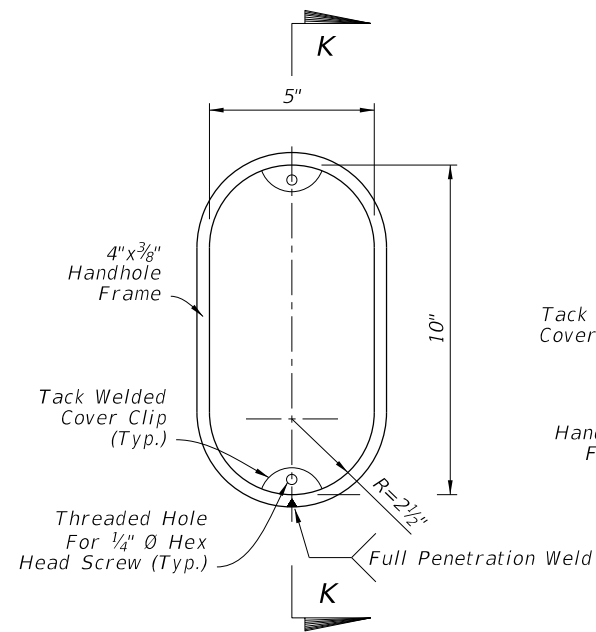

FRAME

HANDHOLE

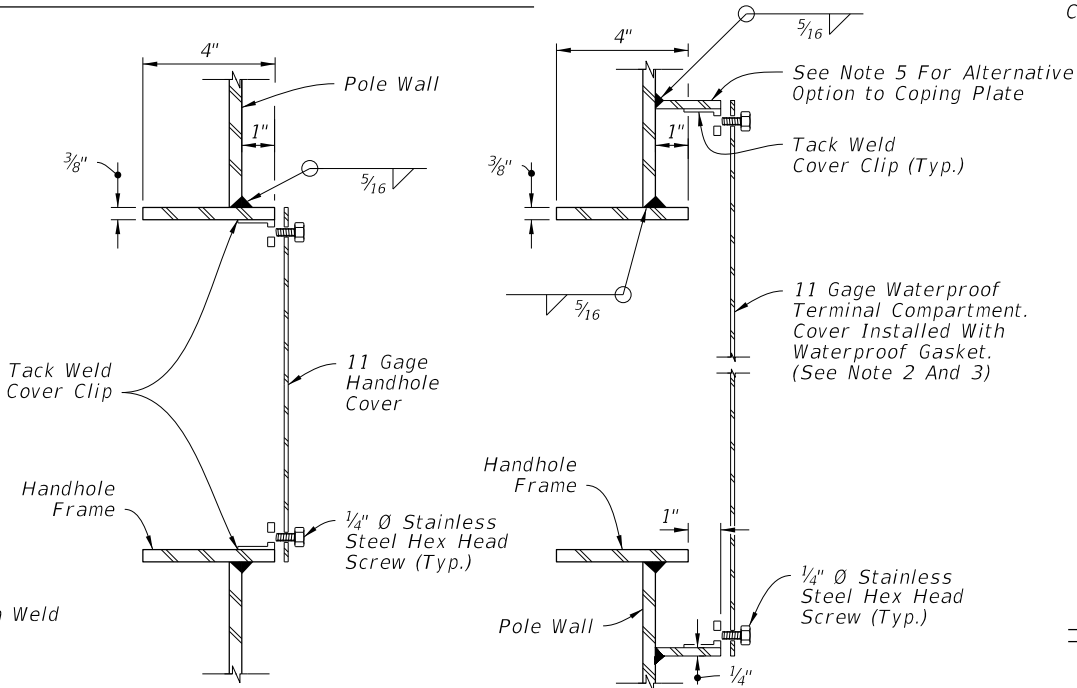

SECTION K-K (Thru Handhole)

SECTION K-K (Terminal Compartment)

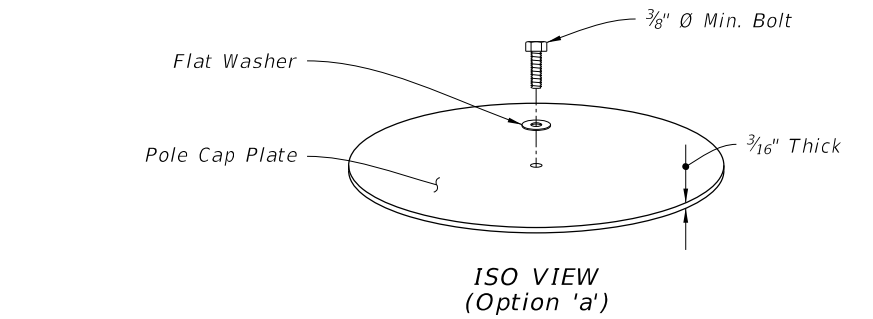

ISO VIEW (Option 'a')

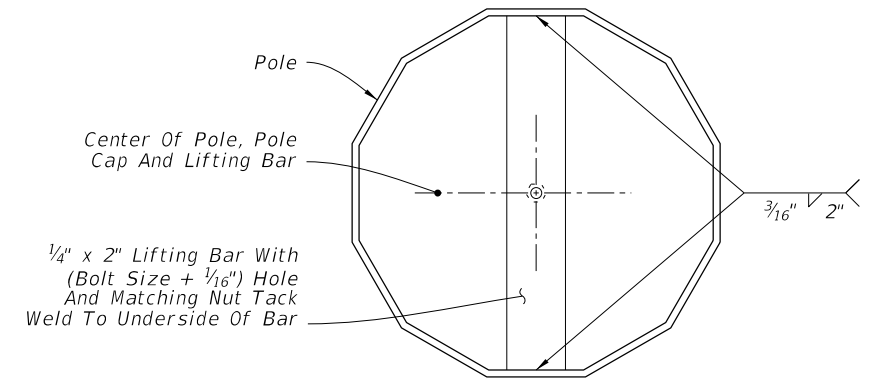

TOP VIEW (Option 'a')

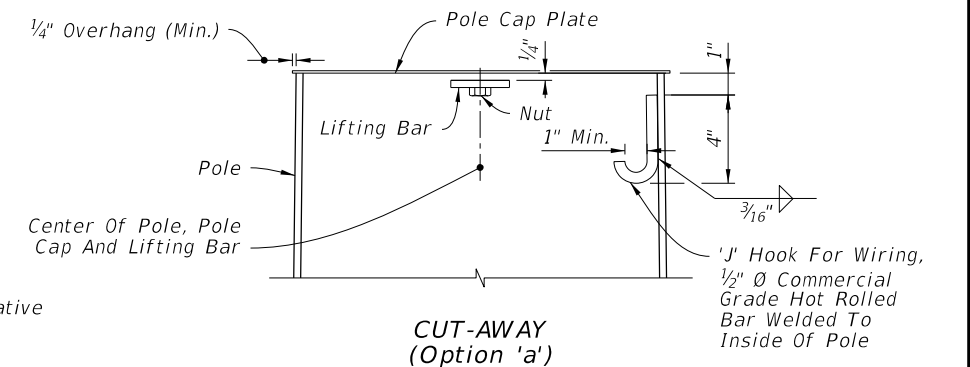

CUT-AWAY (Option 'a')

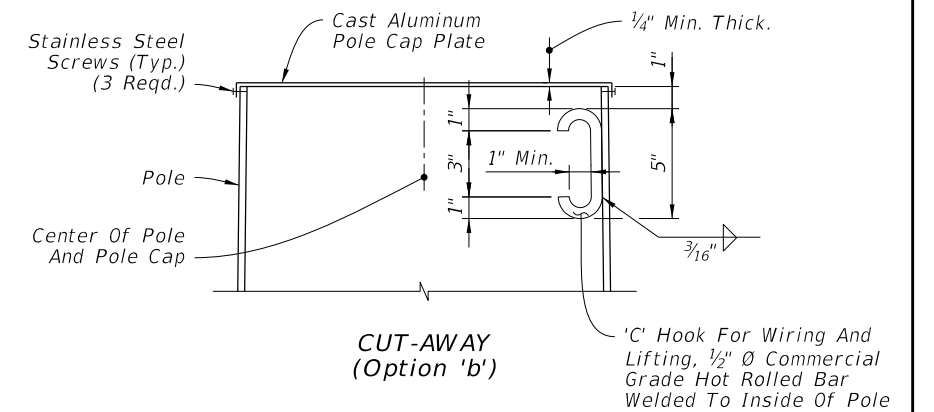

CUT-AWAY (Option 'b')

POLE TOP

HANDHOLE AND POLE TOP DETAILS

10/16/2022 2:32:07 PM

LAST REVISION 11/01/21	REVISION	DESCRIPTION:
---------------------------	----------	--------------