

NOTES:

1. Work with Index 634-001 for grounding and span wire details. See the Plans for clamp spacing, cable sizes and forces, signals and sign mounting locations and details.

2. Shop Drawings:

This Index is considered fully detailed, only submit shop drawings for minor modifications not detailed in the Plans.

3. Materials:

A. Strain Pole and Backing Rings:

- a. Less than 3/16": ASTM A1011 Grade 50, 55, 60 or 65
- b. Greater than or equal to 3/16": ASTM A572 Grade 50, 55, 60 or 65
- c. ASTM A595 Grade A (55 ksi yield) or Grade B (60 ksi yield)

B. Steel Plates: ASTM A36

C. Weld Metal: E70XX

D. Bolts, Nuts and Washers:

- a. High Strength Bolts: ASTM F3125, Grade A325, Type 1
- b. Nuts: ASTM A563 Grade DH Heavy-Hex
- c. Washers: ASTM F436 Type 1, one under turned element

E. Anchor Bolts, Nuts and Washers:

- a. Anchor Bolts: ASTM F1554 Grade 55
- b. Nuts: ASTM A563 Grade A Heavy-Hex (5 per anchor bolt)
- c. Plate Washers: ASTM A36 (2 per bolt). Split-lock washers and self-locking nuts are not permitted

F. Handhole Frame: ASTM A709 or ASTM A36, Grade 36

G. Handhole Cover: ASTM A1011 Grade 50, 55, 60 or 65

H. Aluminum Pole Caps and Nut Covers: ASTM B26 (319-F)

I. Stainless Steel Screws: AISI Type 316

J. Threaded Bars/Studs: ASTM A36 or ASTM A307

K. Concrete: Class IV (Drilled Shaft) for all environmental classifications.

L. Reinforcing Steel: Specification 415

4. Fabrication:

A. Pole Taper: Change diameter at a rate of 0.14 inches per foot, round or 12-sided (Min.)

B. Upright splines are not permitted. Transverse welds are only permitted at the base.

C. Provide bolt hole diameters as follows:

- a. Bolts (except Anchor Bolts): Bolt diameter plus 1/16", prior to galvanizing.
- b. Anchor Bolts: Bolt diameter plus 1/2", maximum.

D. Locate handhole 180° from 2" wire entrance pipe.

E. Identification Tag: (Submit details for approval.)

- a. 2" x 4" (Max.) aluminum identification tag.
- b. Locate on the inside of the pole and visible from the handhole.
- c. Secure to pole with 1/8" diameter stainless steel rivets or screws.
- d. Include the following information on the ID Tag:

- 1. Financial Project ID
- 2. Pole Type
- 3. Pole height
- 4. Manufacturers' Name
- 5. Fy of Steel
- 6. Base Wall Thickness

F. Provide a 'J' or 'C' hook at the top of the pole for signal wiring support (See Sheet 3).

G. Perform all welding in accordance with Specification 460-6.4.

H. Fabricate longitudinal seam welds in pole with 60 percent minimum penetration or fusion welds except, within 6" of the base plate connection use full-penetration groove welds.

I. Hot Dip Galvanize after fabrication.

5. Coatings:

A. All Nuts, Bolts, Washers and Threaded Bars/Studs: ASTM F2329

B. All other steel items including plate washers: ASTM A123

6. Construction:

A. Foundation: Specification 455, except that payment is included in the cost of the strain pole.

B. After installation, place wire screen between top of foundation and bottom of base plate in accordance with Specification 649-6.

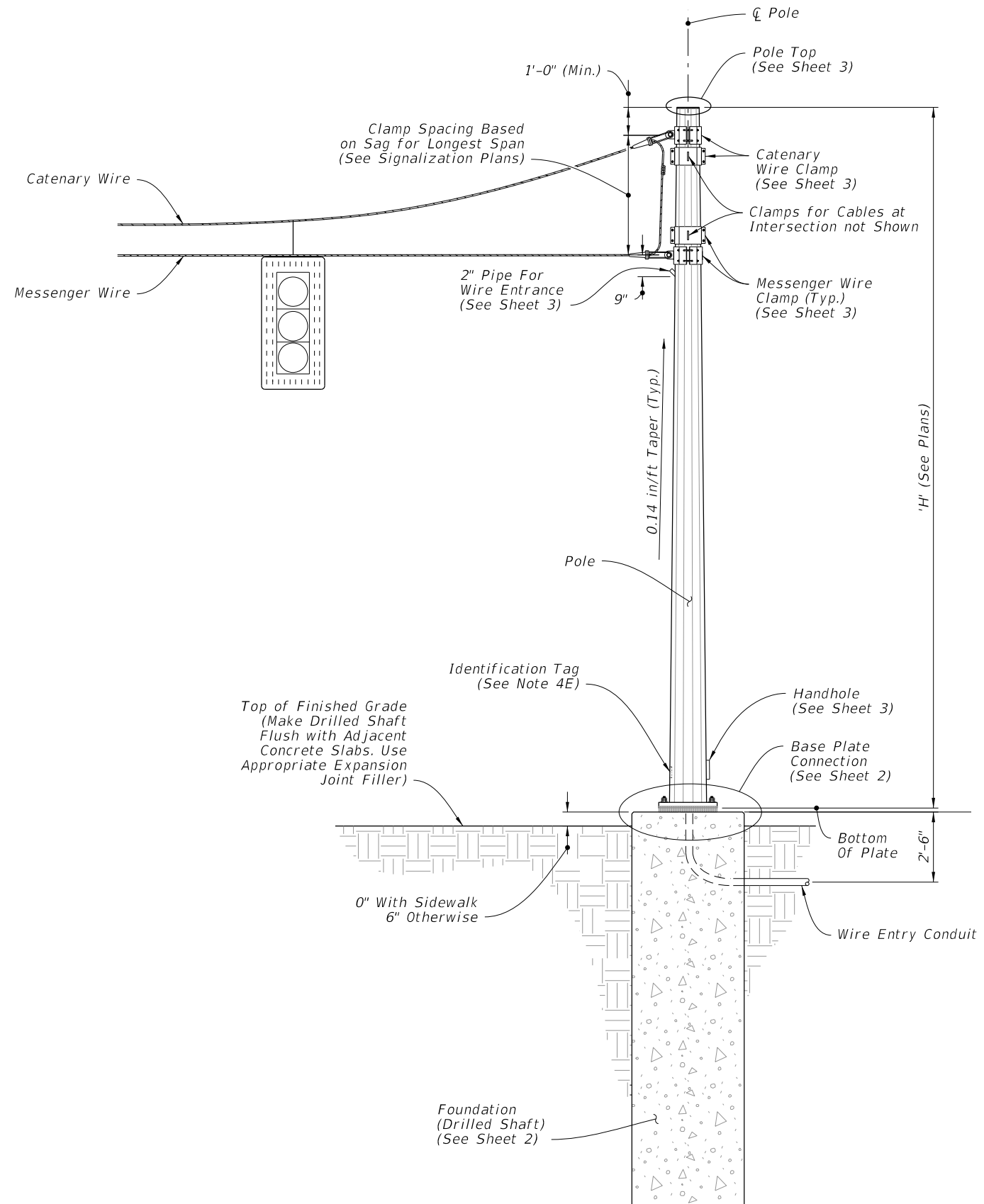

STRAIN POLE ASSEMBLY

ELEVATION AND NOTES

10/6/2022 2:31:06 PM

LAST REVISION 11/01/19	REVISION	DESCRIPTION:		FY 2023-24 STANDARD PLANS	STEEL STRAIN POLE	INDEX 649-010	SHEET 1 of 3
---------------------------	----------	--------------	---	------------------------------	-------------------	------------------	-----------------

POLE TYPE	STEEL STRAIN POLE DATA TABLE									
	POLE		BASE CONNECTION				SHAFT			
	J (in)	K (in)	No. of Bolts	BA (in)	BB (in)	BC (in)	BF (in)	DA (FT)	DB (FT)	No. of #11 Bars
PS-IV	0.250	14	8	25	2.50	1 3/8	60	14	4	14
PS-V	0.313	16	10	28	2.50	1 1/2	60	15	4	14
PS-VI	0.313	18	12	30	2.50	1 1/2	60	16	4	14
PS-VII	0.313	21	14	33	2.50	1 1/2	60	16	4.5	16
PS-VIII	0.313	23	16	35	2.50	1 1/2	60	17	4.5	16
PS-IX	0.313	25	12	39	3.00	1 3/4	60	17	5	18
PS-X	0.313	27	14	41	3.00	1 3/4	60	18	5	18

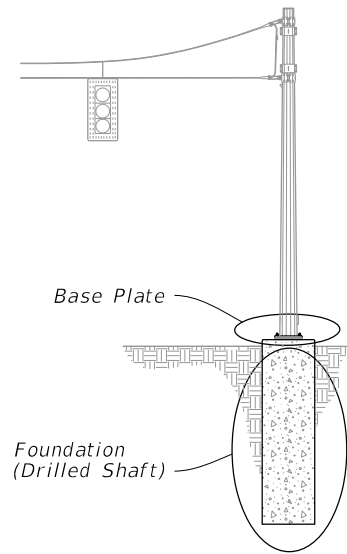

POLE ASSEMBLY

NOTE:

Double Nuts: Bottom nut may be half-height 'jam' nut. Provide individual nut covers (not shown) for each bolt.

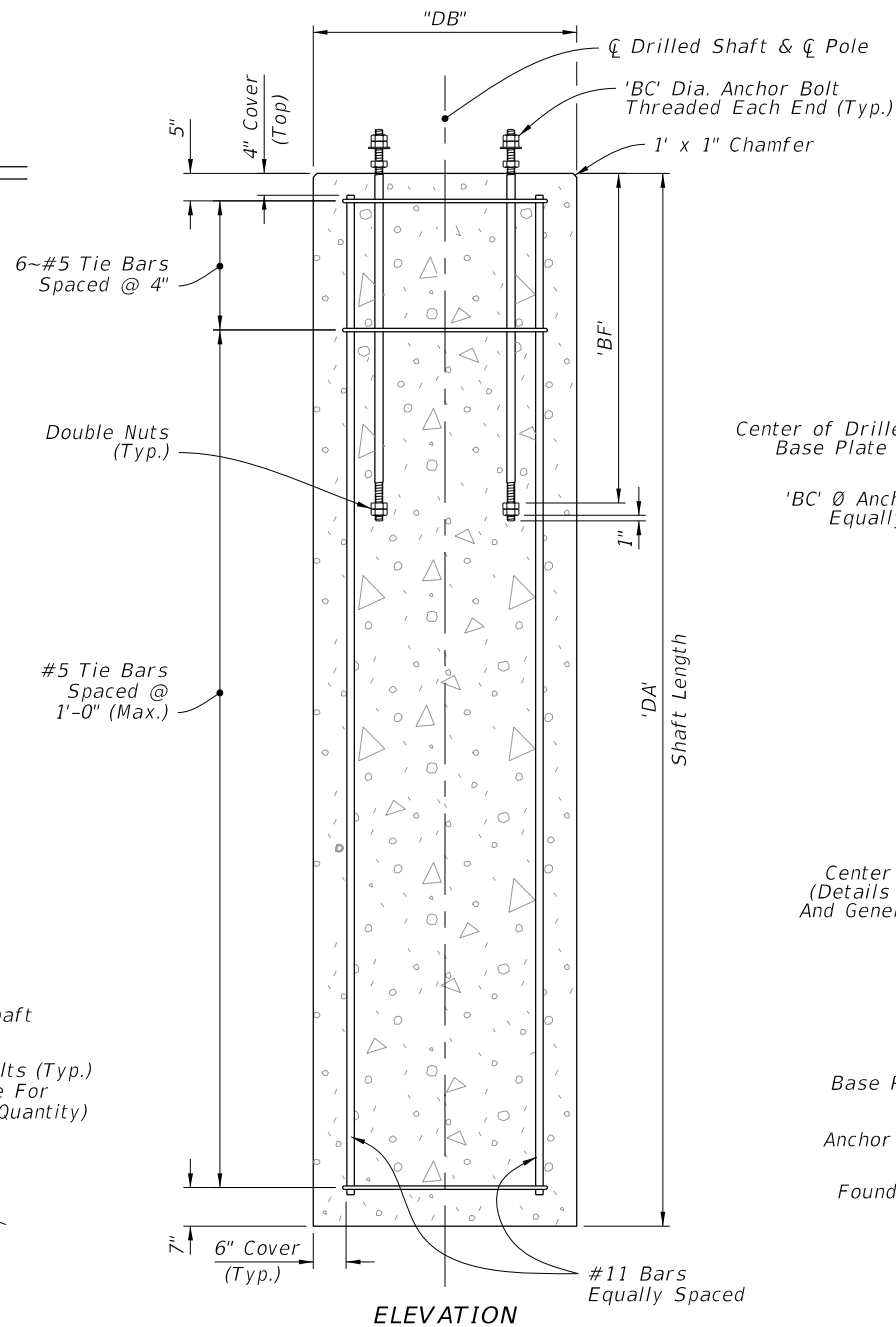

ELEVATION

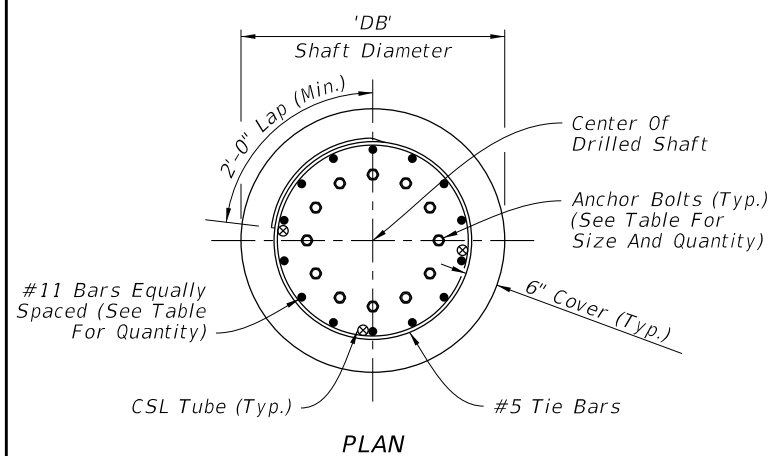

PLAN

FOUNDATION

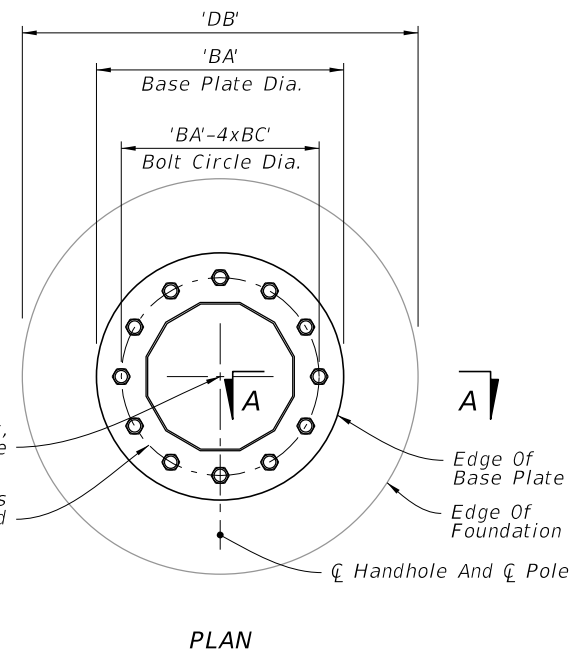

PLAN

BASE PLATE

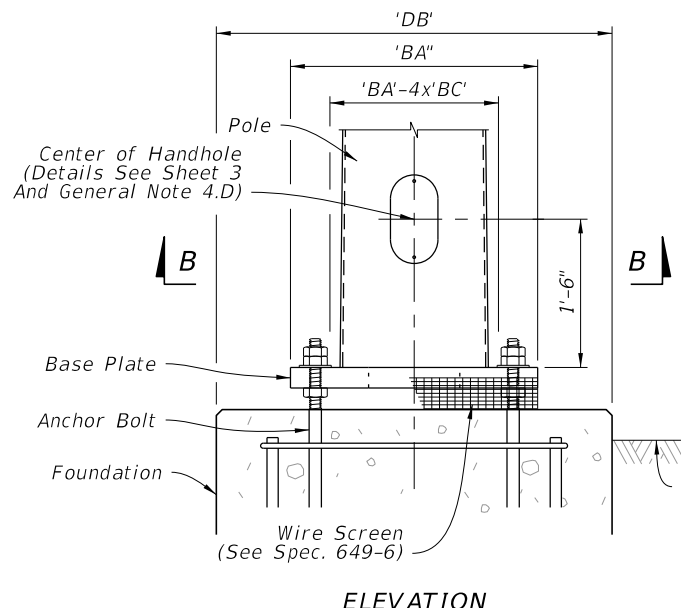

ELEVATION

See Finished Grade Note on Sheet 1

DETAIL 'A'

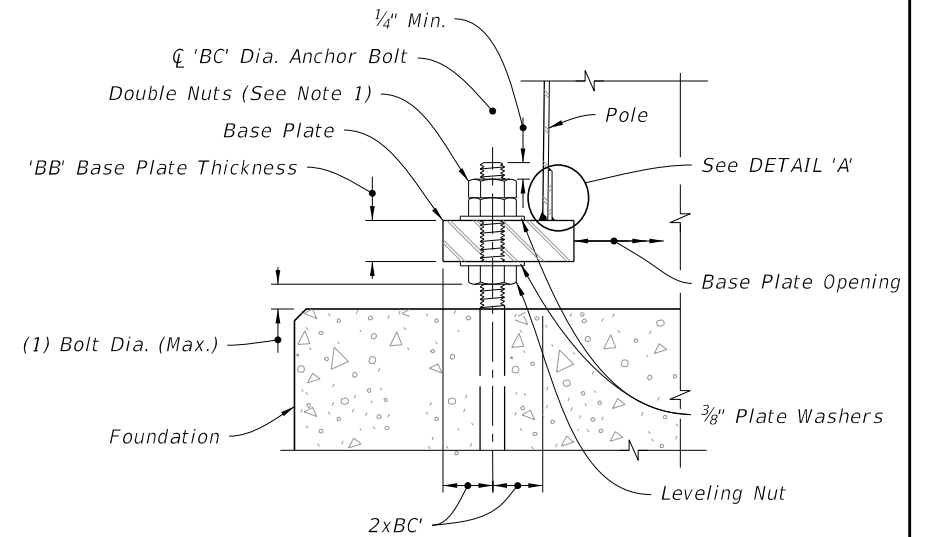

SECTION A-A

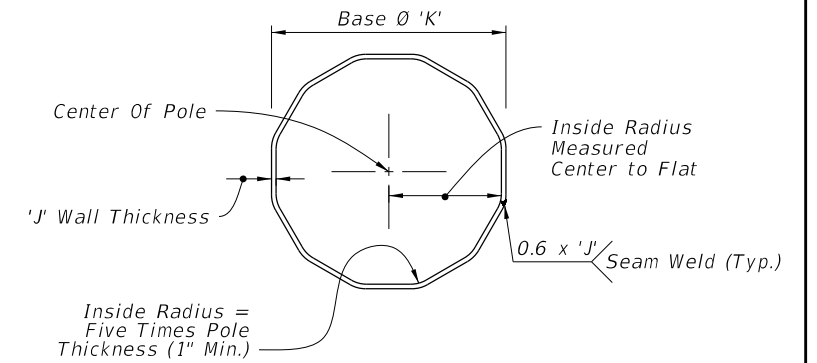

SECTION B-B

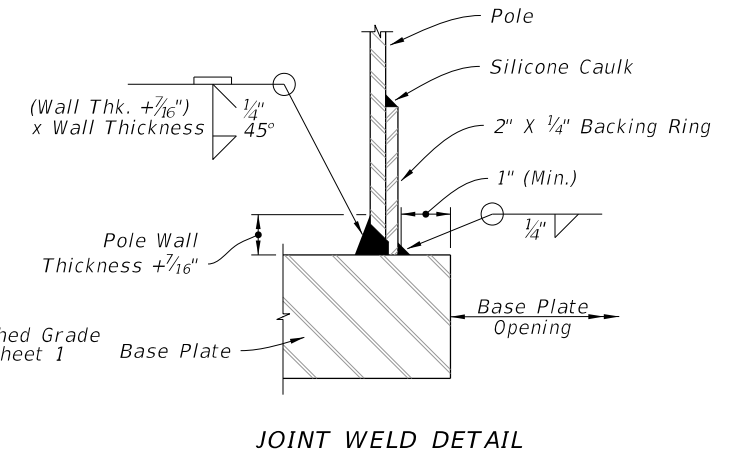

JOINT WELD DETAIL

FOUNDATION AND BASE DETAILS

10/6/2022 2:31:07 PM

LAST REVISION	DESCRIPTION:
11/01/18	



FY 2023-24
STANDARD PLANS

STEEL STRAIN POLE

INDEX
649-010

SHEET
2 of 3

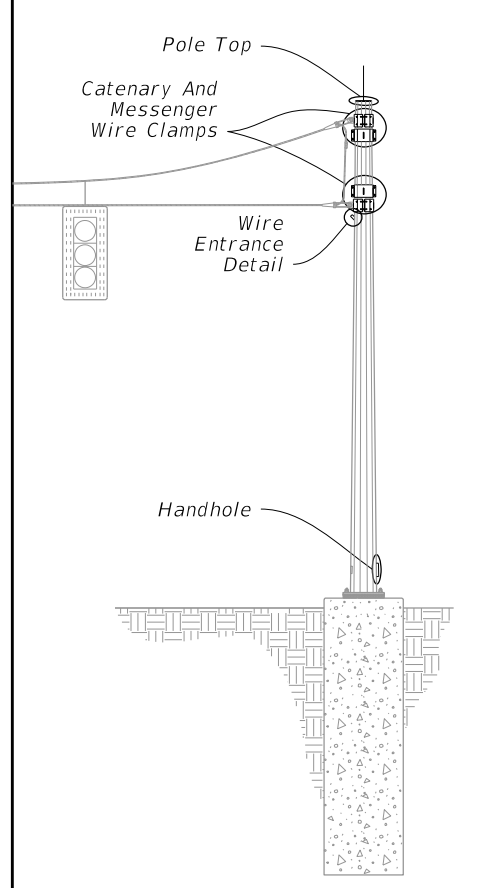

POLE ASSEMBLY

- NOTES:**
1. Clamps have been sized for Design Cable Loads shown in the Clamp Thickness Table, and a Maximum Pole Diameter at the Clamp location of 2'-1". Use one clamp per cable.
 2. Install a properly sized Weather Head, fastened securely to the standard pipe for each pole location. At locations other than the wire entrance, the Weather Head face is to be left closed to outside atmosphere. Wire entrance installed per Index 634-001.
 3. Any combination of Option 'a' or 'b' may be used provided both lifting and wiring is accommodated.

CLAMP THICKNESS TABLE		
Cable Diameter (in.)	Minimum Breaking Strength (kip)	Plate Thickness (in.)
1/2	25	1
7/16	18	7/8
3/8	11.5	3/4
1/4	3.15	3/8

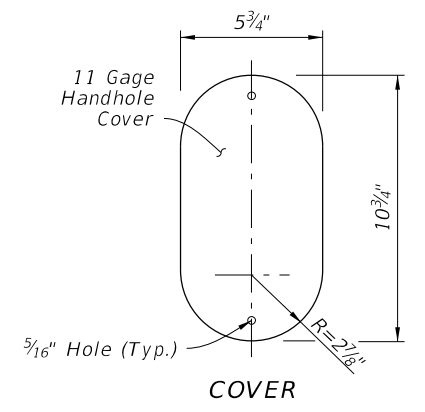

COVER

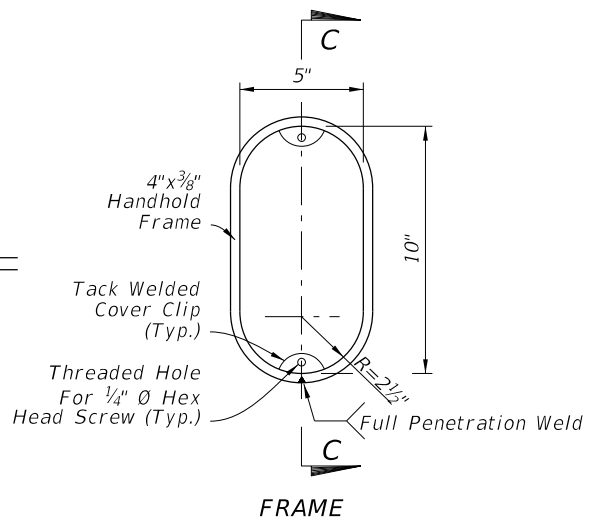

FRAME

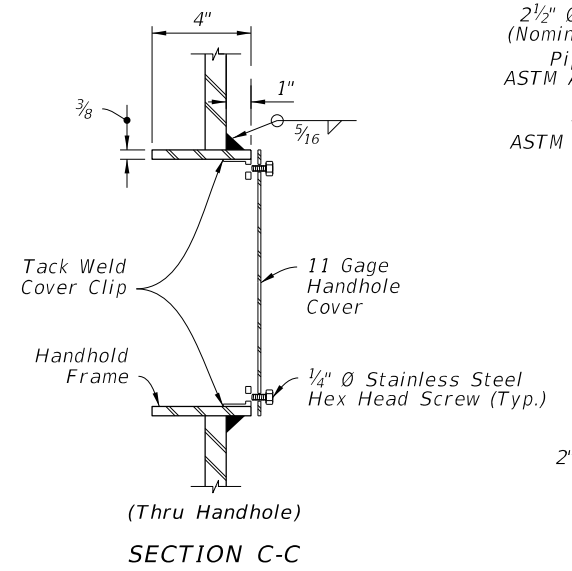

SECTION C-C

HANDHOLE

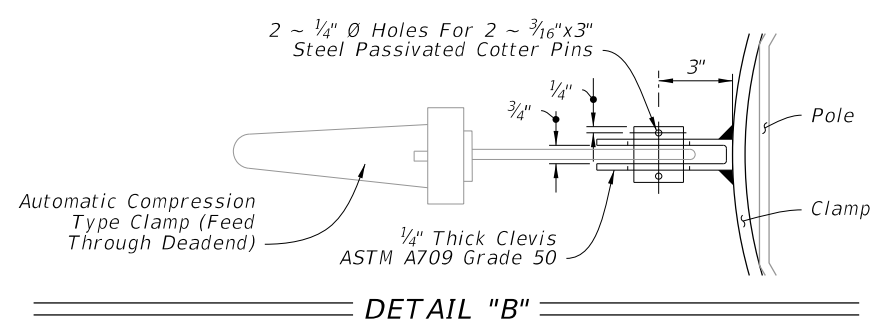

DETAIL "B"

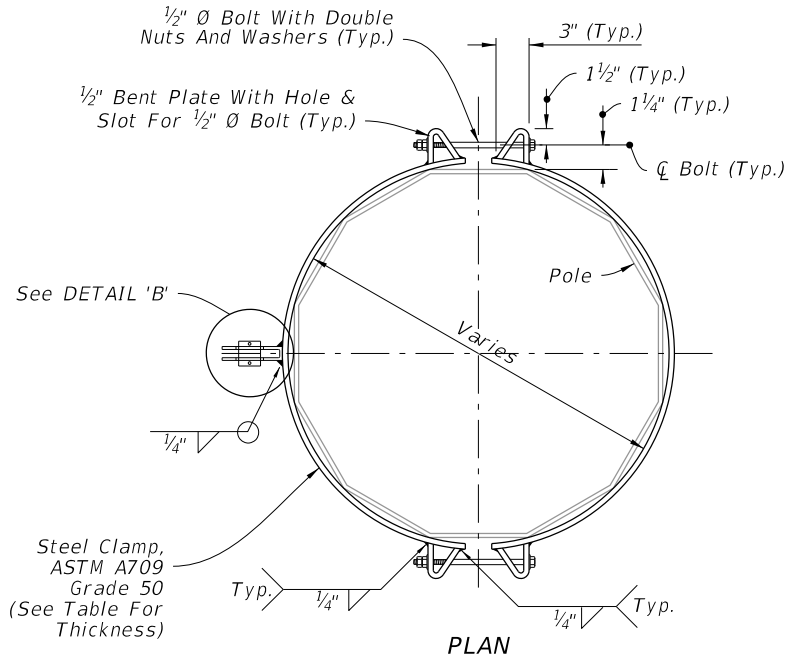

PLAN

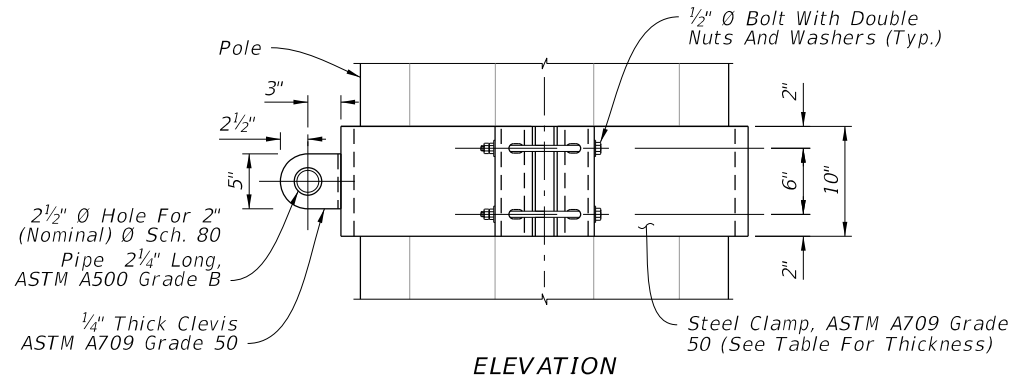

ELEVATION

CATENARY AND MESSENGER WIRE CLAMPS

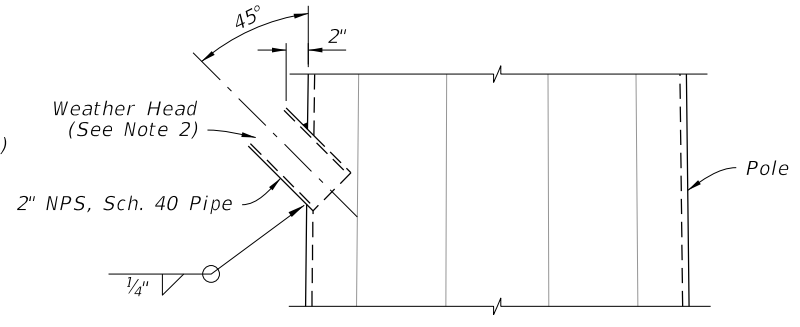

WIRE ENTRANCE DETAIL

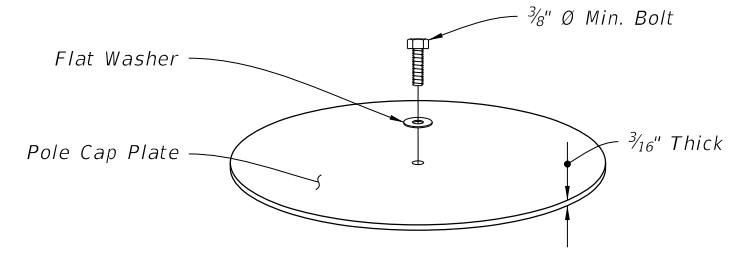

TOP VIEW

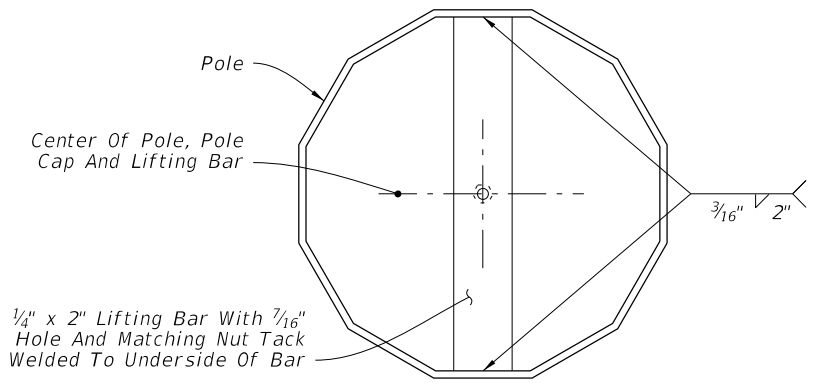

TOP VIEW

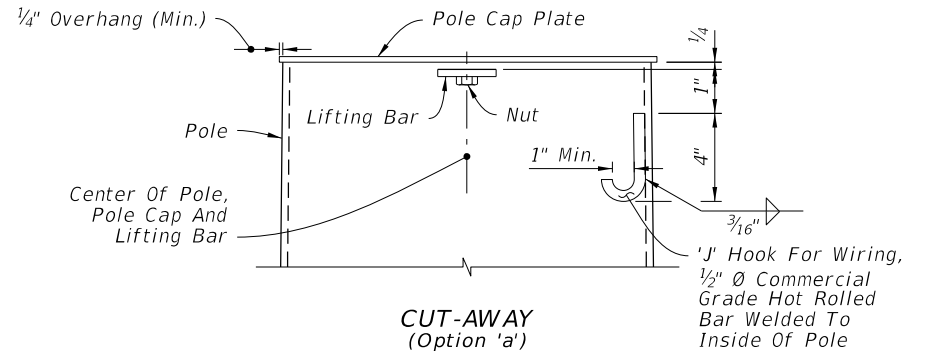

CUT-AWAY (Option 'a')

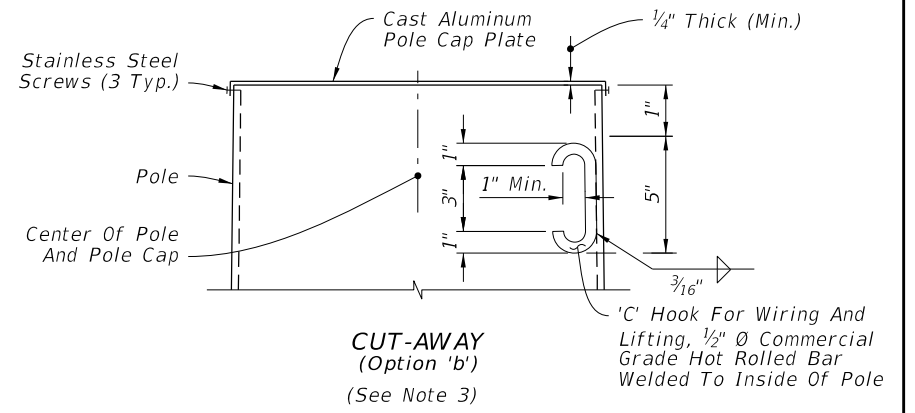

CUT-AWAY (Option 'b')

POLE TOP

ATTACHMENT DETAILS

10/16/2022 2:31:08 PM