

* Guardrail or Crash Cushion may also be shown in the Contract Plans, in lieu of the Tapered End Transition.

SCHEMATIC PLAN VIEW - NEAR LANE APPROACH

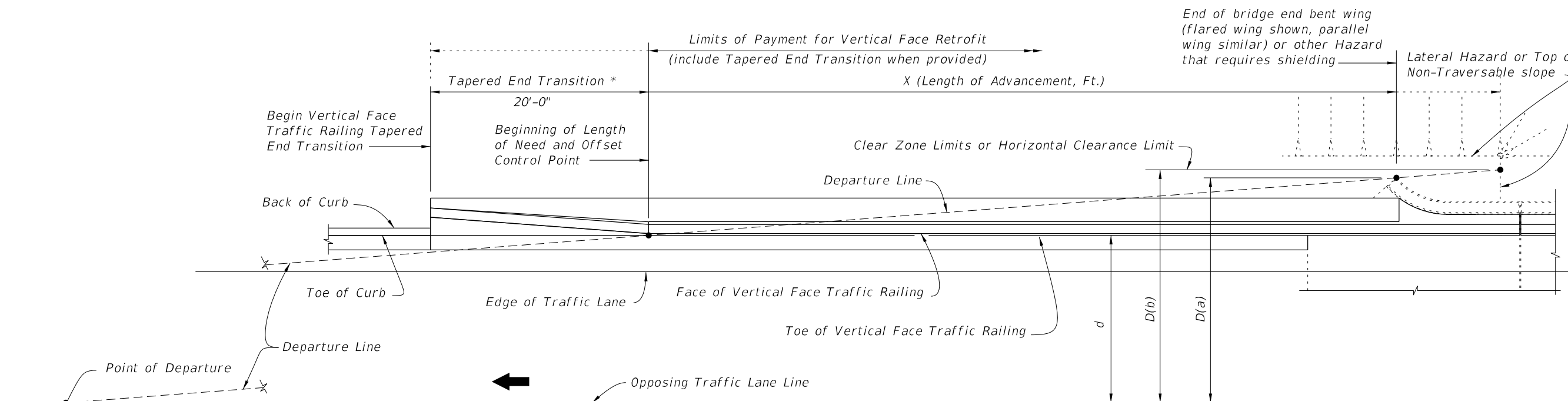

SCHEMATIC PLAN VIEW - OPPOSING LANE APPROACH

CROSS REFERENCES:
 For General Notes, Dowel Details, Expansion Dowel Details, Reinforcing Steel Notes and Reinforcing Steel Bending Diagram see Index 521-480.

10/6/2022 12:51:27 PM

LAST REVISION 07/01/09	REVISION DESCRIPTION:	 FY 2023-24 STANDARD PLANS	TRAFFIC RAILING - (VERTICAL FACE RETROFIT) SPREAD FOOTING APPROACH	INDEX 521-484	SHEET 1 of 10
---------------------------	-----------------------	--	---	------------------	------------------

Approach Slab Transition
(See Schemes 1 thru 7 for
Details and Reinforcement)

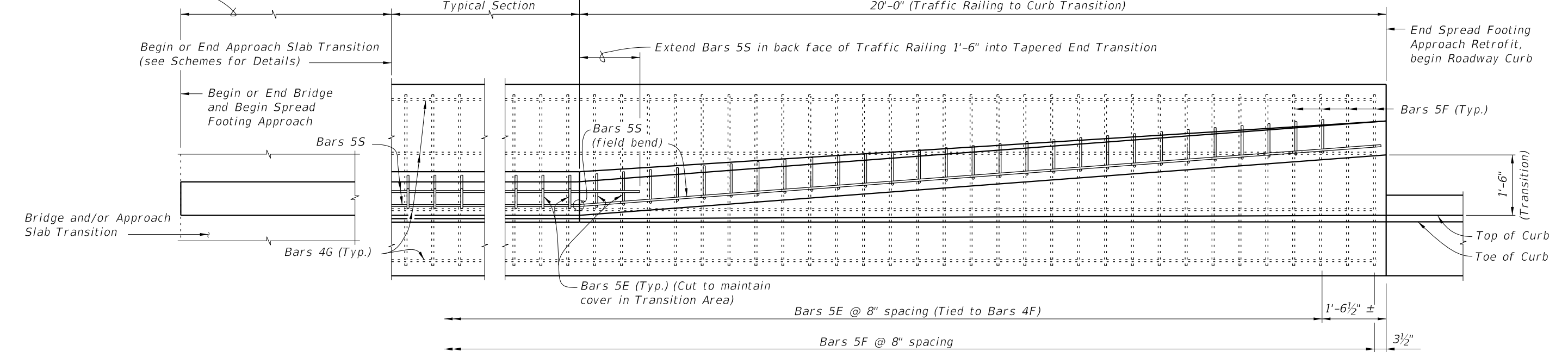

PARTIAL PLAN VIEW

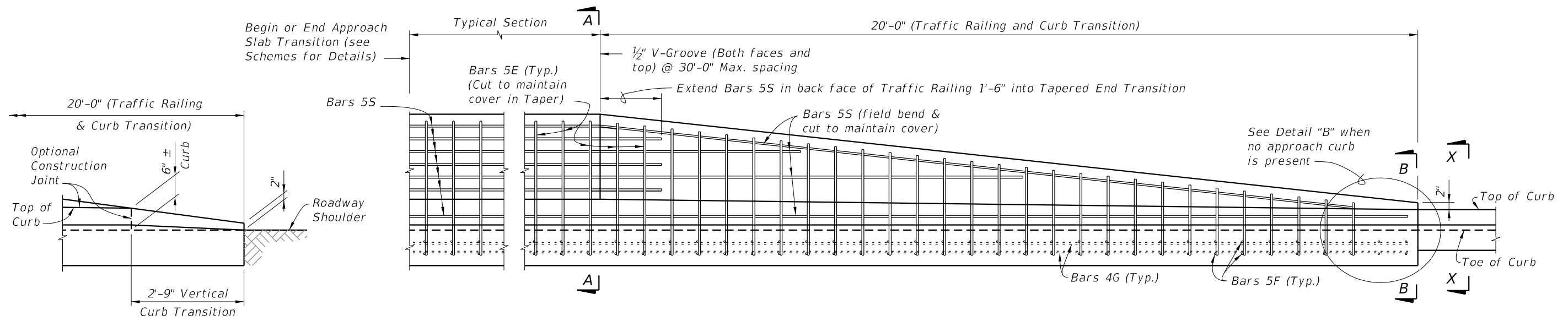

PARTIAL ELEVATION VIEW

DETAIL "B"
TRANSITION TO NON-CURB APPROACH
(Reinforcing Not Shown For Clarity)

TAPERED END TRANSITION

CROSS REFERENCES:
For Section A-A, B-B and X-X see Sheet 4.

10/6/2022 12:51:27 PM

LAST REVISION 07/01/09	REVISION	DESCRIPTION:		FY 2023-24 STANDARD PLANS	TRAFFIC RAILING - (VERTICAL FACE RETROFIT) SPREAD FOOTING APPROACH	INDEX 521-484	SHEET 2 of 10
---------------------------	----------	--------------	---	------------------------------	---	------------------	------------------

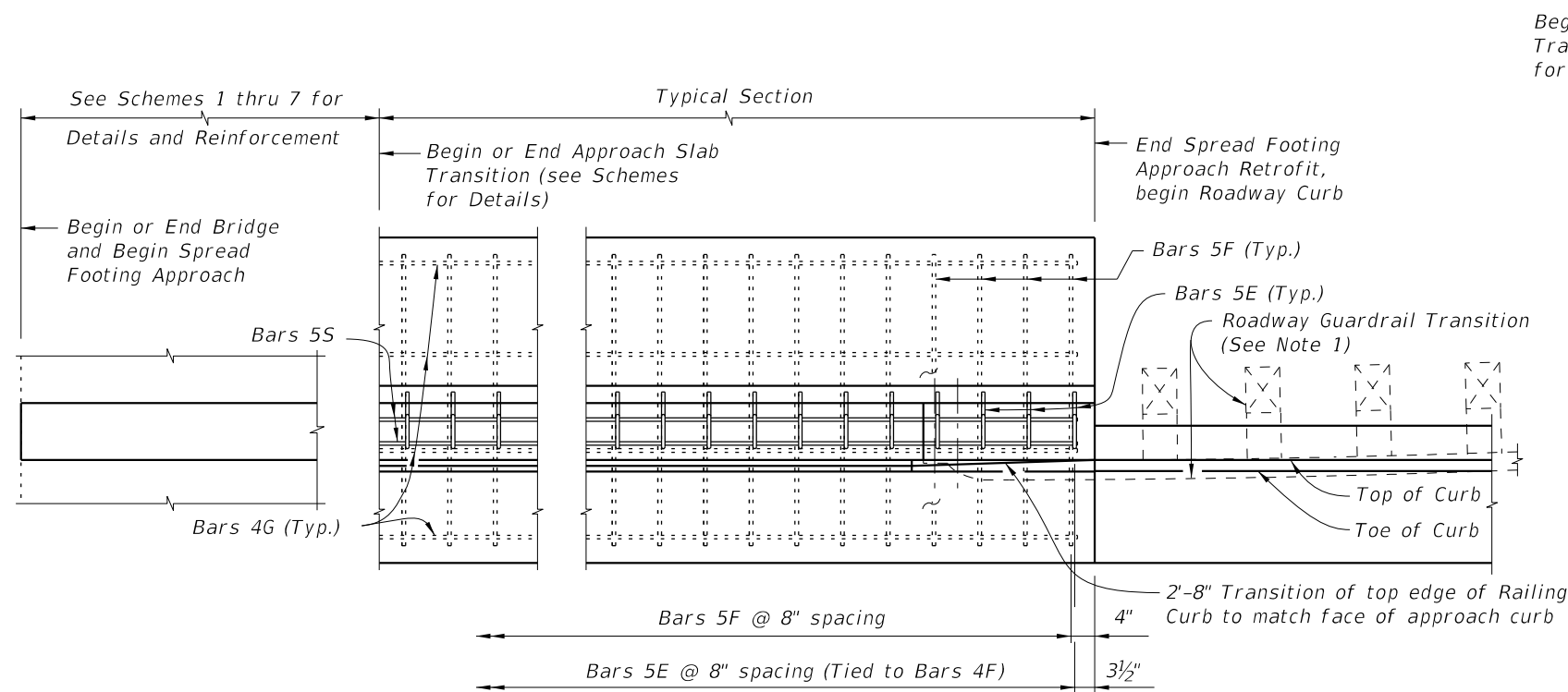

**PARTIAL PLAN VIEW
(With Curb Approach)**

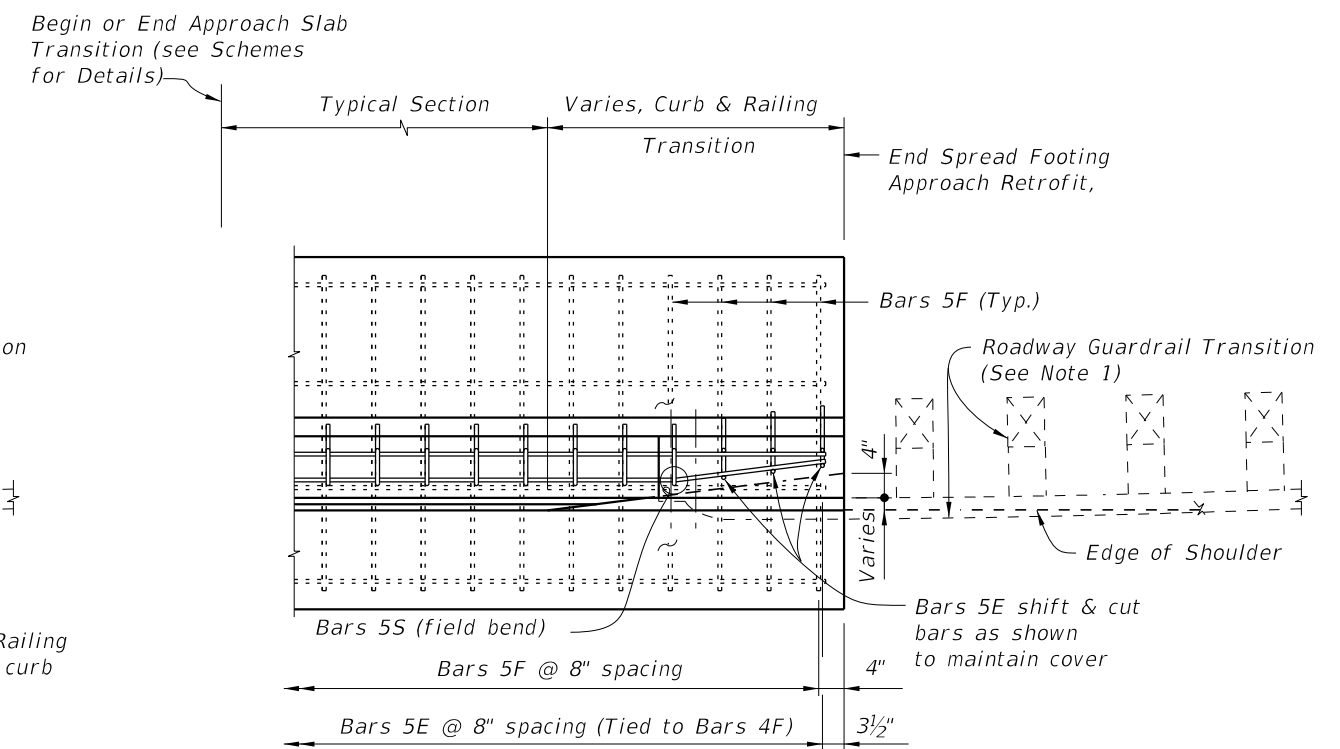

**PARTIAL PLAN VIEW
(Without Curb Approach)**

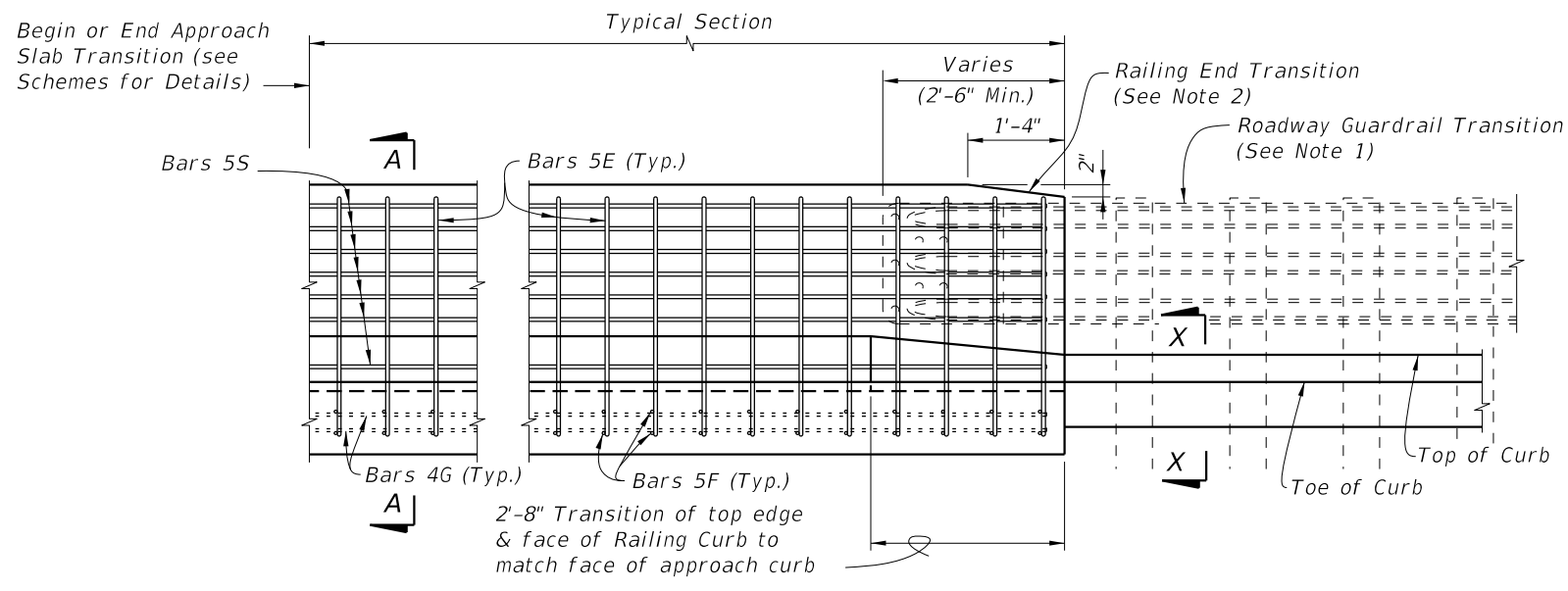

**PARTIAL ELEVATION VIEW
(With Curb Approach)**

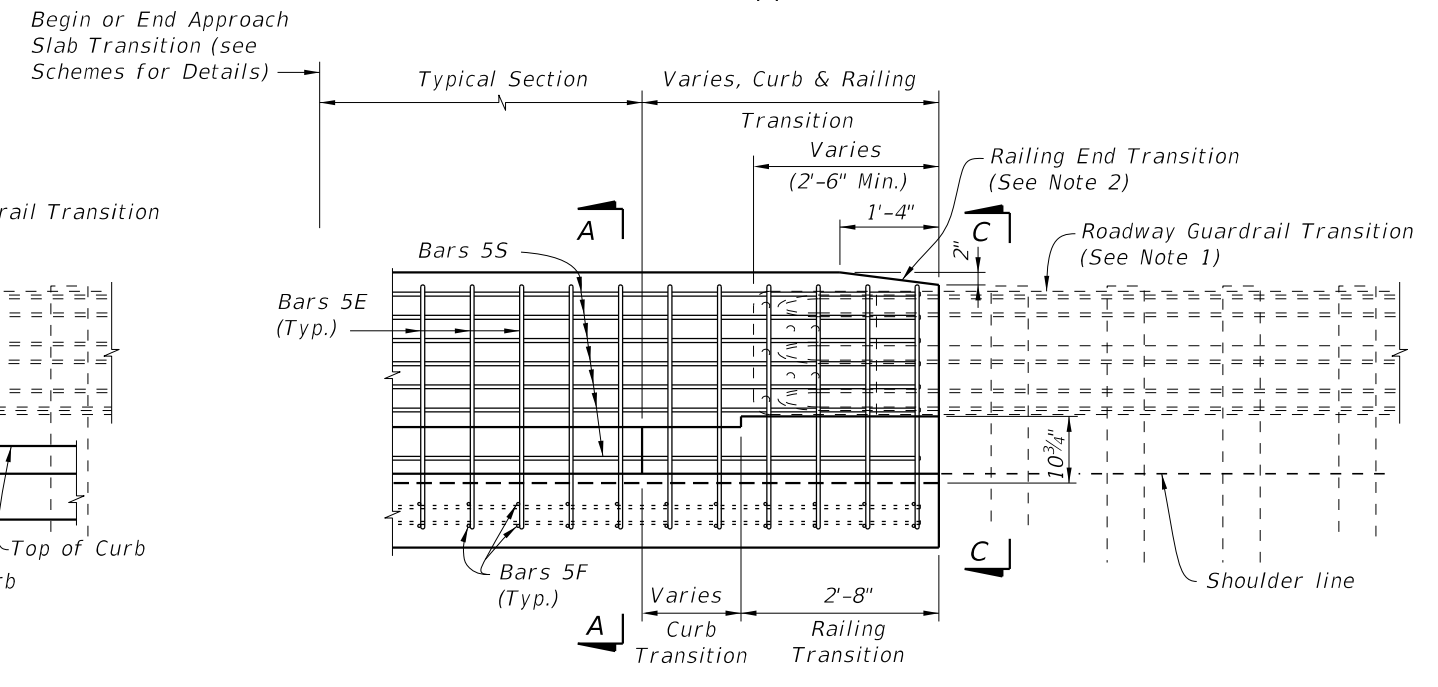

**PARTIAL ELEVATION VIEW
(Without Curb Approach)**

GUARDRAIL END TRANSITION

- NOTES:**
1. On approach end provide a Roadway Guardrail Transition, Index 536-002 (Sheet 16 - Scheme 1) or other site specific treatment. See Roadway Plans for limiting station of Roadway Guardrail Transition or other site specific treatment.
 2. Provide Railing & Curb Base Transitions (as shown) if curb does not extend beyond end of Spread Footing Approach, see Roadway Plans. Railing End Transition & Railing & Curb Base Transitions may be omitted on trailing ends with no opposing traffic.

CROSS REFERENCES:
For Section A-A, C-C and X-X see Sheet 4.

10/10/2022 7:36:39 AM

LAST REVISION 07/01/09	REVISION	DESCRIPTION:		FY 2023-24 STANDARD PLANS	TRAFFIC RAILING - (VERTICAL FACE RETROFIT) SPREAD FOOTING APPROACH	INDEX 521-484	SHEET 3 of 10
---------------------------	----------	--------------	--	------------------------------	---	------------------	------------------

ESTIMATED TRAFFIC RAILING RETROFIT SPREAD FOOTING APPROACH QUANTITIES		
ITEM	UNIT	QUANTITY
		9" Curb
Concrete - Typical Section	CY/Ft.	0.25
Reinforcing Steel - Typical Section	Lb./Ft.	38
Concrete - 20'-0" Tapered End Transition plus Footing	CY	4.57 Total
Reinforcing Steel - 20'-0" Tapered End Transition plus Footing	Lb.	776 Total

NOTE: Quantities are based on a 9" curb, no curb cross slope.

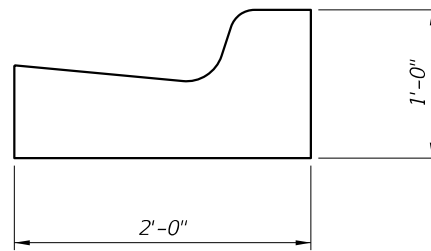

SECTION X-X (TYPICAL CURB, TYPE VARIES, TYPE F SHOWN)
(See Index 520-001 and Plans for Details)

* Match Cross Slope of high side and low side at begin or end bridge or approach slab.

** Match curb height of adjacent bridge and approach slab. Adjust height in Transition area to match adjoining Roadway curb.

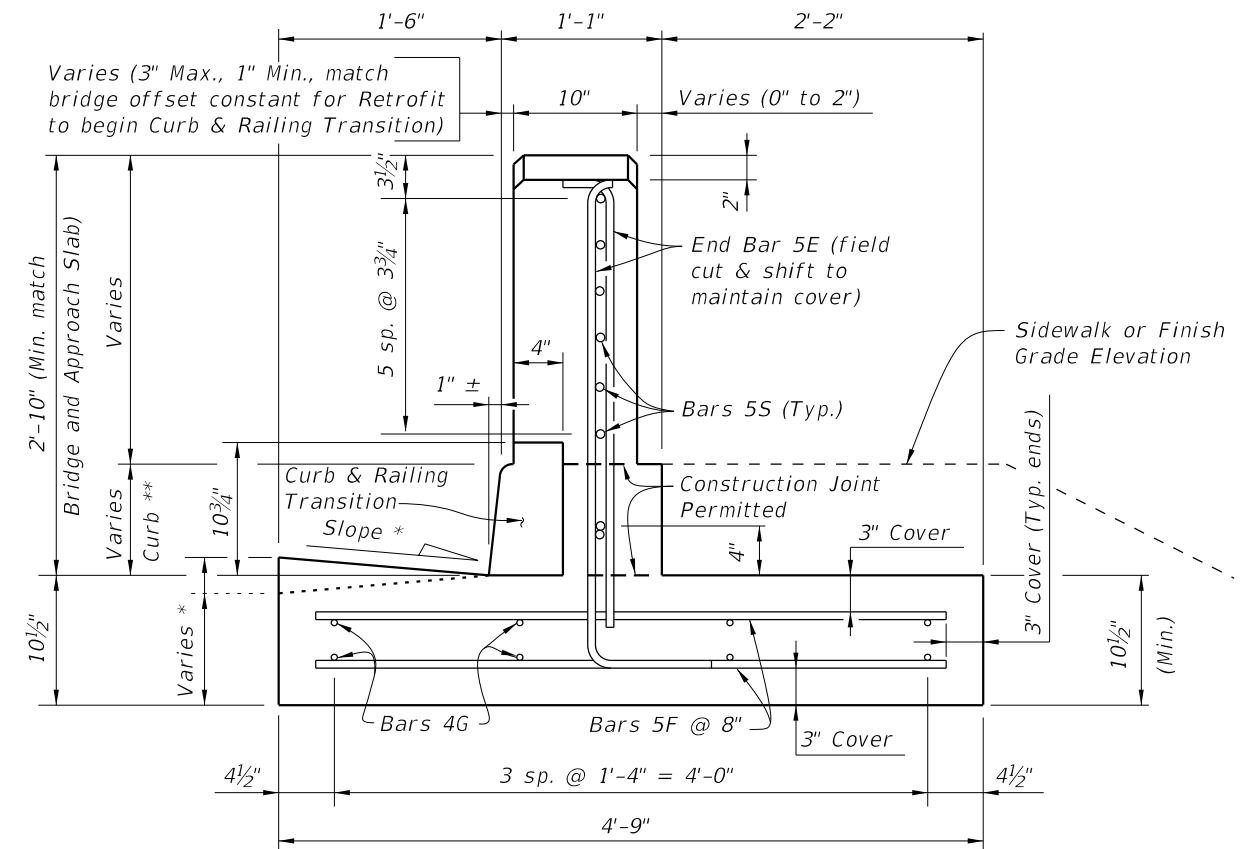

SECTION C-C
(GUARDRAIL END TRANSITION)

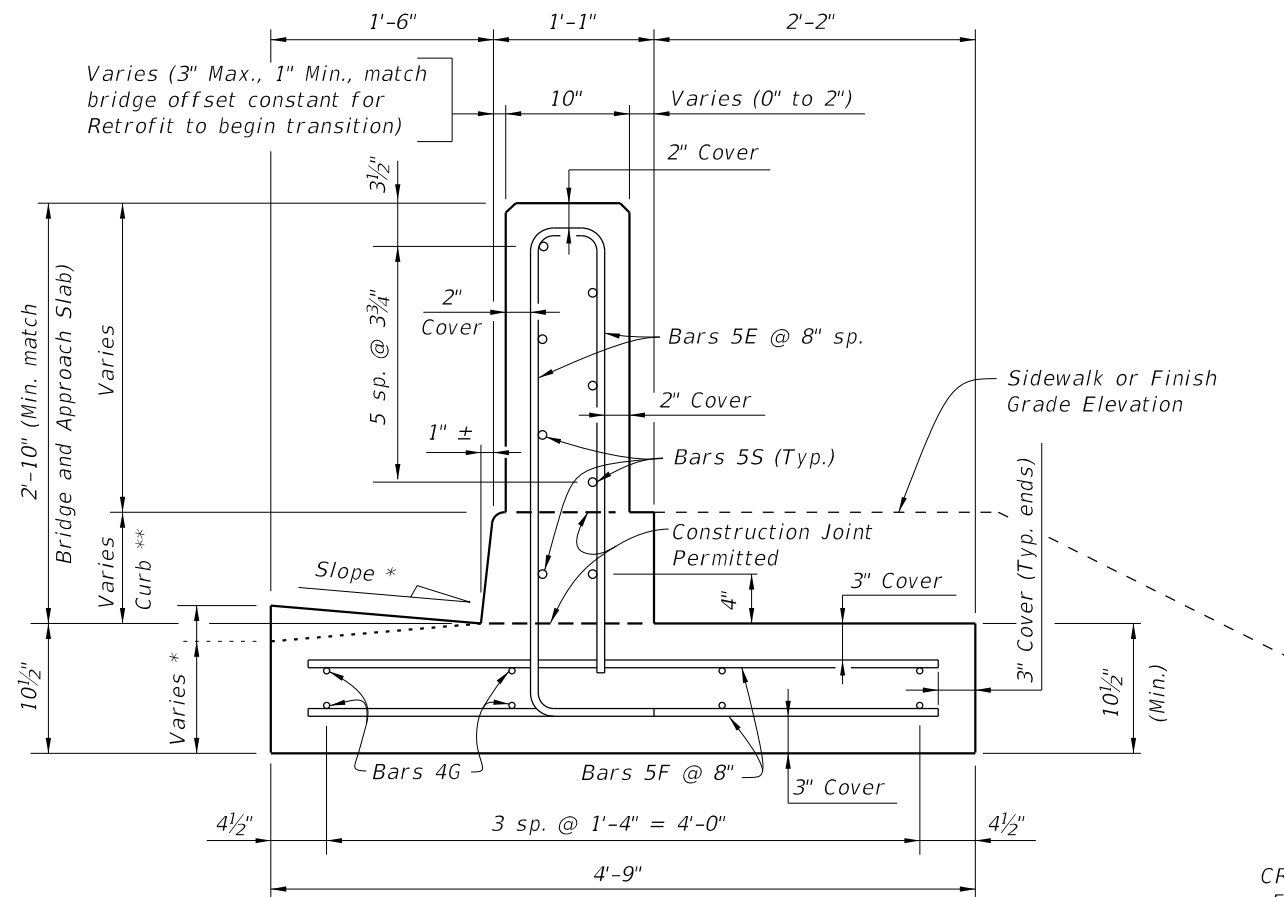

SECTION A-A
TYPICAL SECTION
(9" Curb shown, 6" Curb similar)

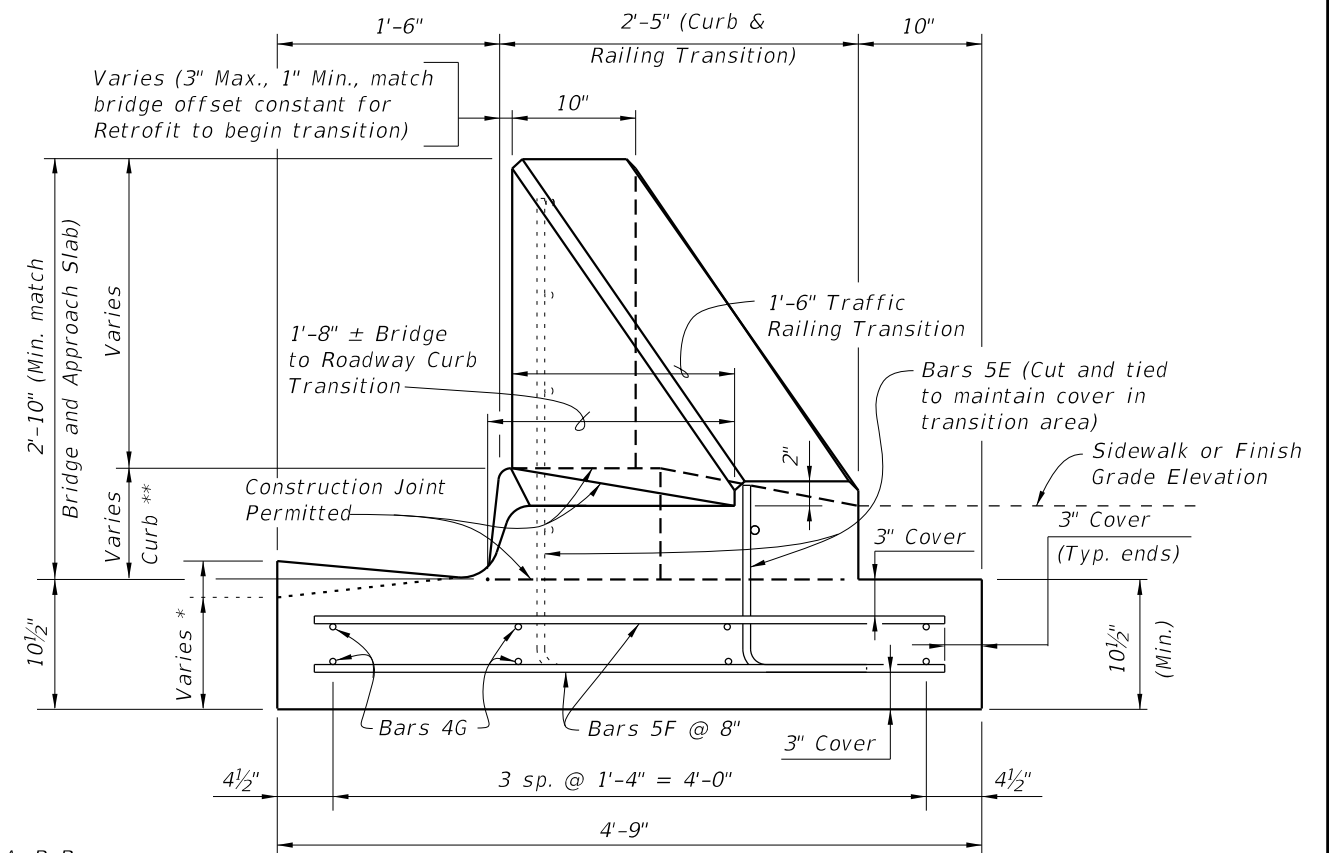

SECTION B-B
TAPERED END TRANSITION
(Bars 5S not shown for clarity)

CROSS REFERENCES:
For location of Sections A-A, B-B and X-X see Sheet 2.
For location of Section C-C see Sheet 3.

10/6/2022 12:51:29 PM

LAST REVISION	DESCRIPTION:
07/01/09	



FY 2023-24
STANDARD PLANS

TRAFFIC RAILING - (VERTICAL FACE RETROFIT)
SPREAD FOOTING APPROACH

INDEX
521-484

SHEET
4 of 10

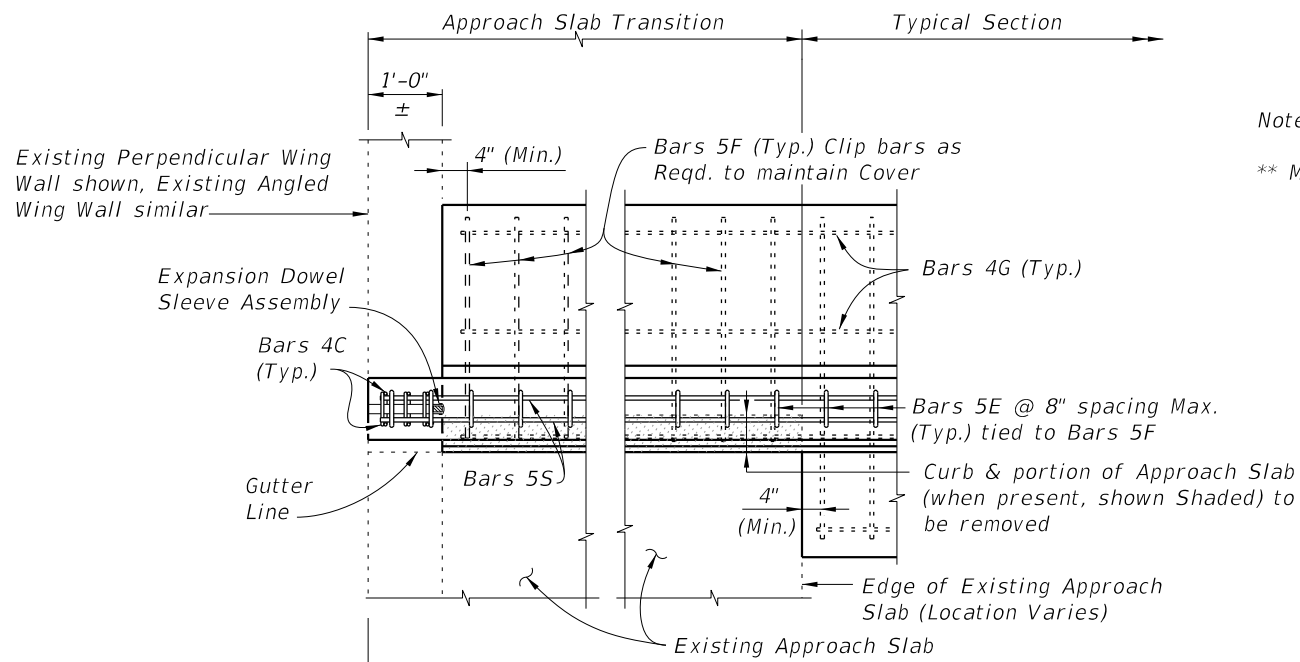

Note:
 ** Match curb height of adjacent bridge and approach slab.

PARTIAL PLAN

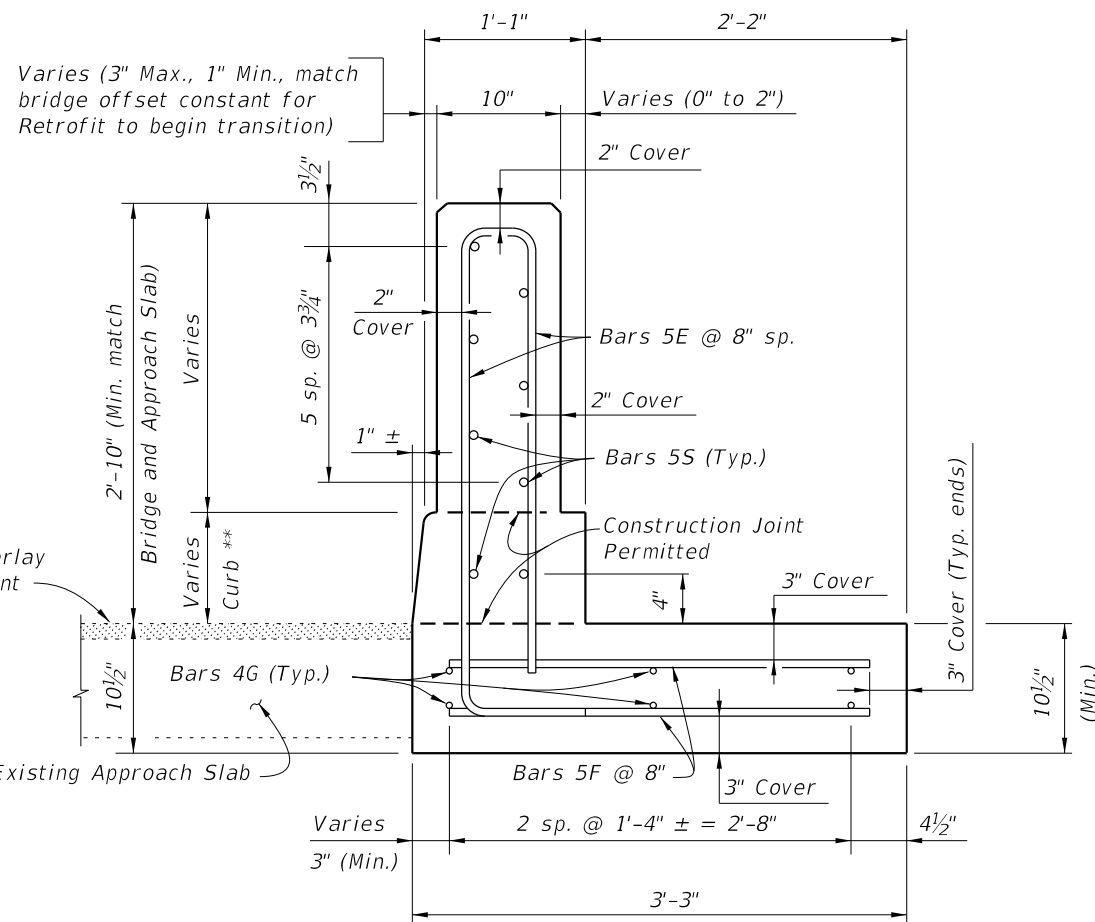

SECTION D-D

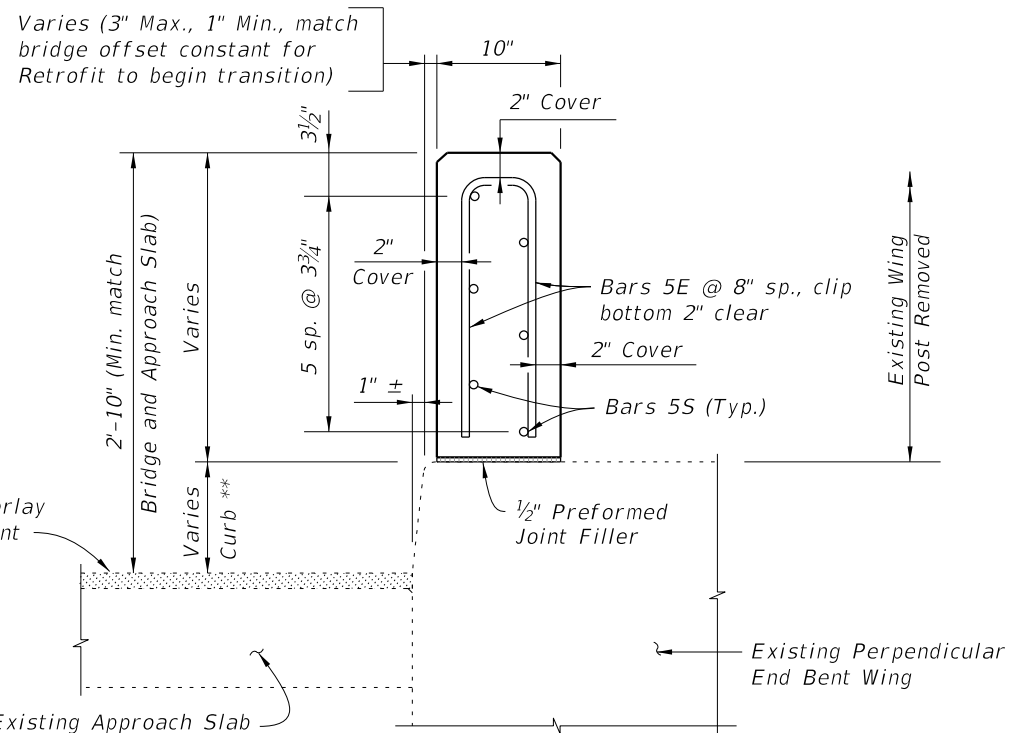

SECTION E-E (NARROW CURB SHOWN, WIDE AND INTERMEDIATE CURBS SIMILAR)

Front Face of Backwall, Begin or End Bridge & Match Line (See Index 521-481, 521-482 & 521-483 Sheet 1)

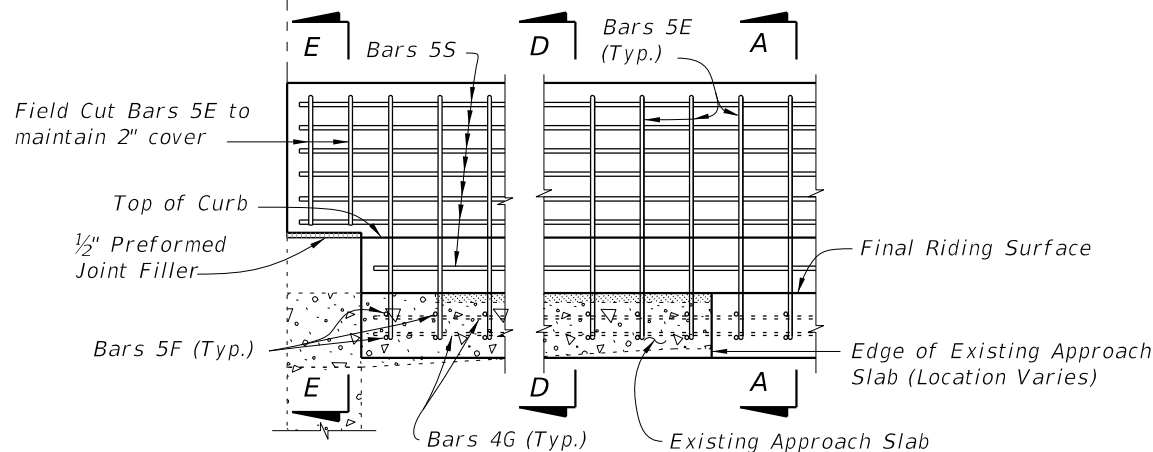

PARTIAL ELEVATION OF INSIDE FACE OF RAILING
 (Expansion Dowel Assemblies and Bars 4C not shown for clarity)

SCHEME 1 ~ MODIFICATION FOR INDEX 521-481, 521-482 AND 521-483 - SCHEME 1
RAILING END TREATMENT FOR PERPENDICULAR OR ANGLED WING WALLS WITH NARROW CURBS (SHOWN), WIDE CURBS AND INTERMEDIATE CURBS (SIMILAR)

CROSS REFERENCE:
 For Section A-A see Sheet 4.
 For Expansion Dowel Assembly and placement of Dowel Bars 6D Details see Index 521-480.

10/6/2022 12:51:30 PM

LAST REVISION 07/01/09	REVISION	DESCRIPTION:		FY 2023-24 STANDARD PLANS	TRAFFIC RAILING - (VERTICAL FACE RETROFIT) SPREAD FOOTING APPROACH	INDEX 521-484	SHEET 5 of 10
---------------------------	----------	--------------	--	------------------------------	---	------------------	------------------

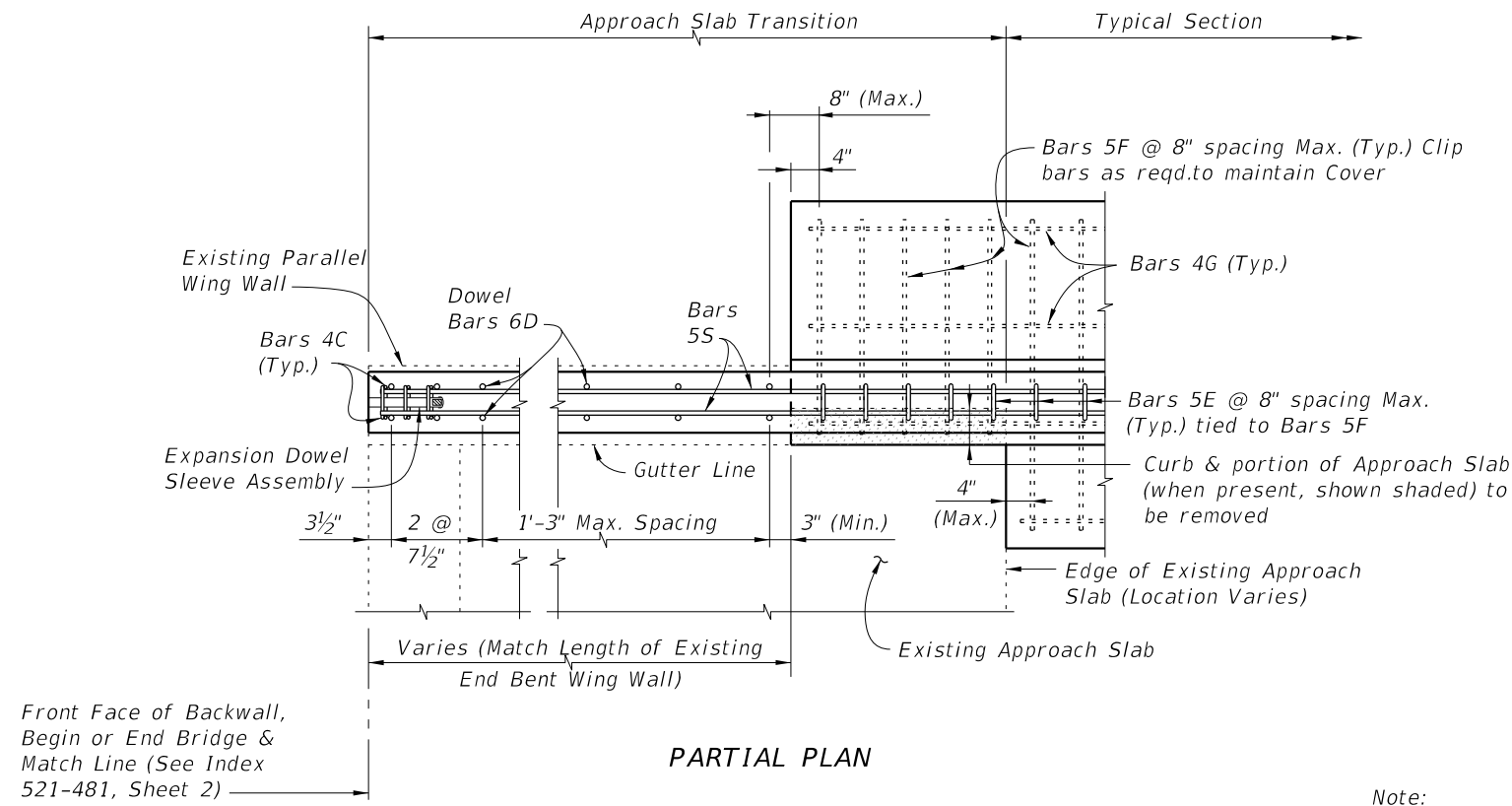

PARTIAL PLAN

Note:
** Match curb height at adjoining existing end bent wing.

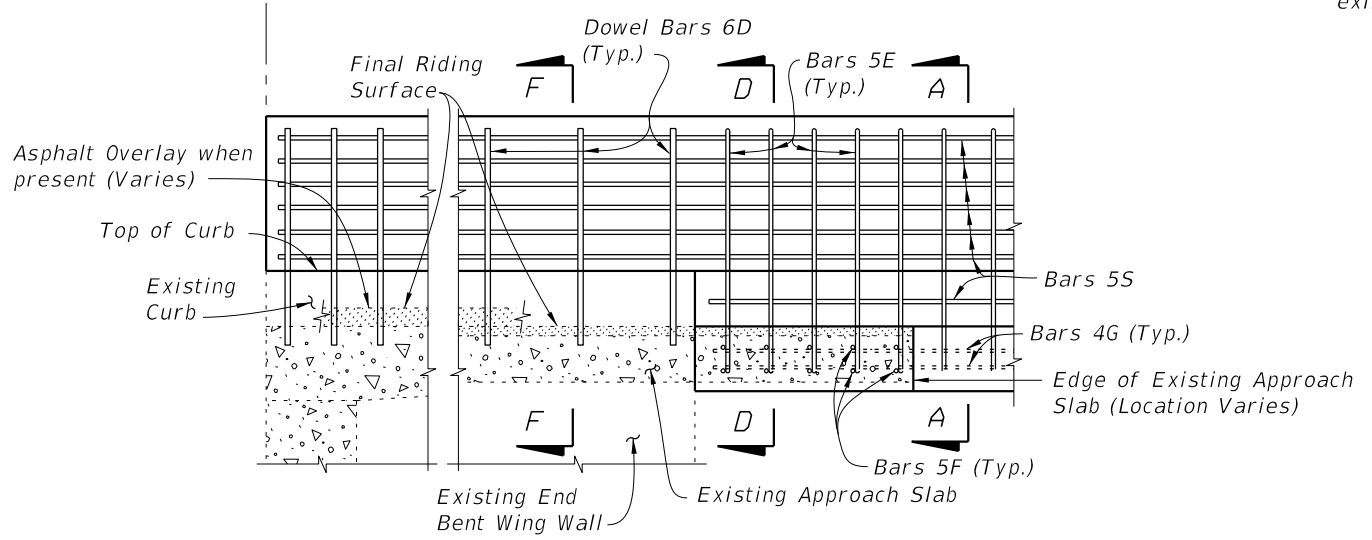

PARTIAL ELEVATION OF INSIDE FACE OF RAILING
(Expansion Dowel Assemblies and Bars 4C not shown for clarity)

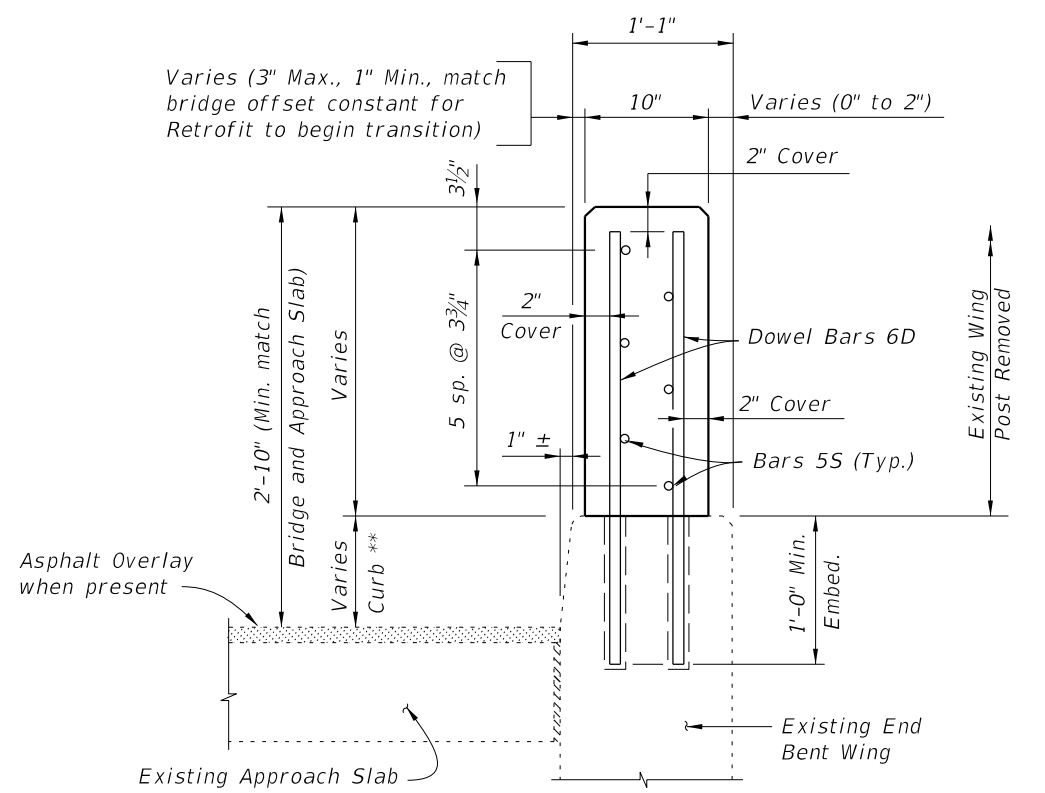

SECTION F-F

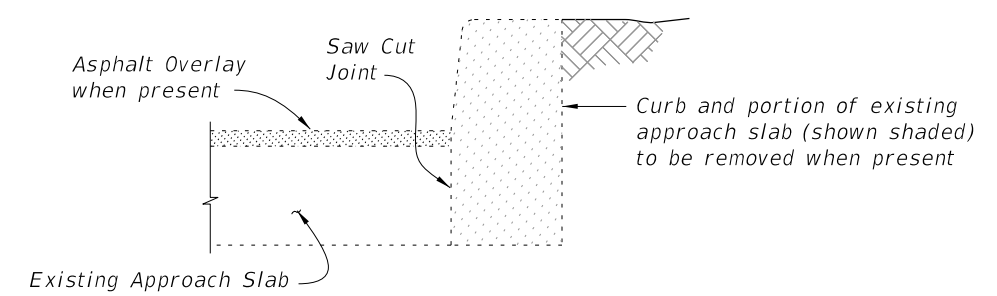

SECTION THRU EXISTING CURB AND APPROACH SLAB TO BE REMOVED
(Free Standing Curb Similar)

SCHEME 2 ~ MODIFICATION FOR INDEX 521-481 - SCHEME 2
RAILING END TREATMENT FOR PARALLEL WING WALLS WITH NARROW CURBS

- NOTES:
1. Remove existing concrete along saw cut joints. Existing reinforcing steel may be cut at joint or extended into new concrete. Exposed existing reinforcing not encased in new concrete shall be removed 1" below existing concrete surface and grouted over.

- CROSS REFERENCES:
- For Section A-A see Sheet 4.
 - For Section D-D see Sheet 5.
 - For Expansion Dowel Assembly and placement of Dowel Bars 6D Details see Index 521-480.

10/6/2022 12:51:31 PM

LAST REVISION 07/01/09	REVISION	DESCRIPTION:		FY 2023-24 STANDARD PLANS	TRAFFIC RAILING - (VERTICAL FACE RETROFIT) SPREAD FOOTING APPROACH	INDEX 521-484	SHEET 6 of 10
---------------------------	----------	--------------	--	------------------------------	---	------------------	------------------

10/6/2022 12:51:32 PM

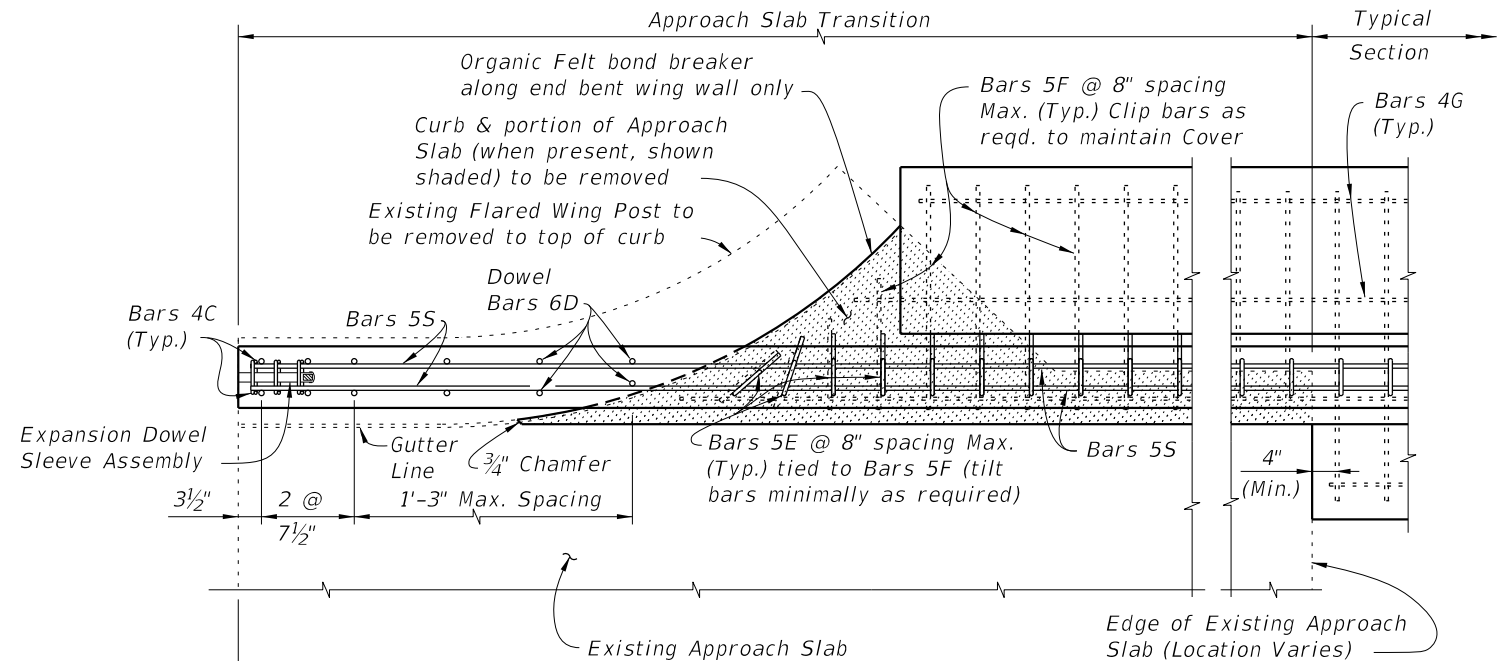

PARTIAL PLAN OF RAILING

Front Face of Backwall, Begin or End Bridge & Match Line (See Index 521-481, Sheet 3)

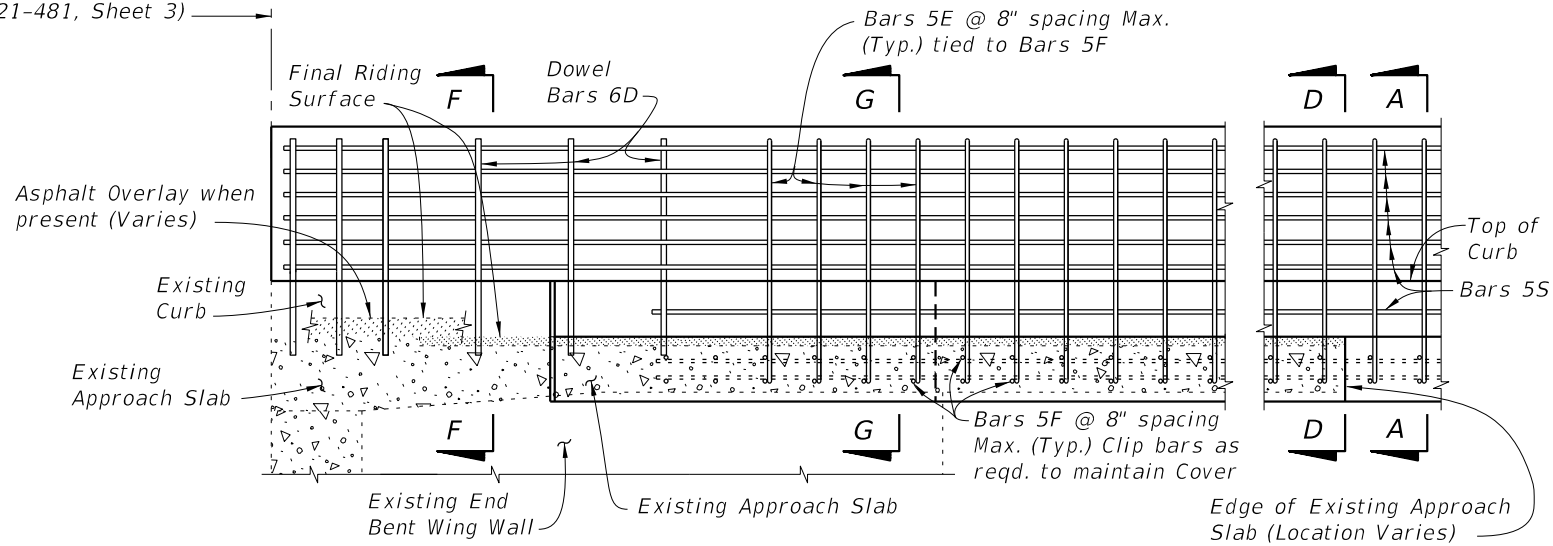

PARTIAL ELEVATION OF INSIDE FACE OF RAILING
(Expansion Dowel Assemblies and Bars 4C not shown for clarity)

SCHEME 3 ~ MODIFICATION FOR INDEX 521-481 SCHEME 3
RAILING END TREATMENT FOR FLARED WING WALLS
WITH NARROW CURBS

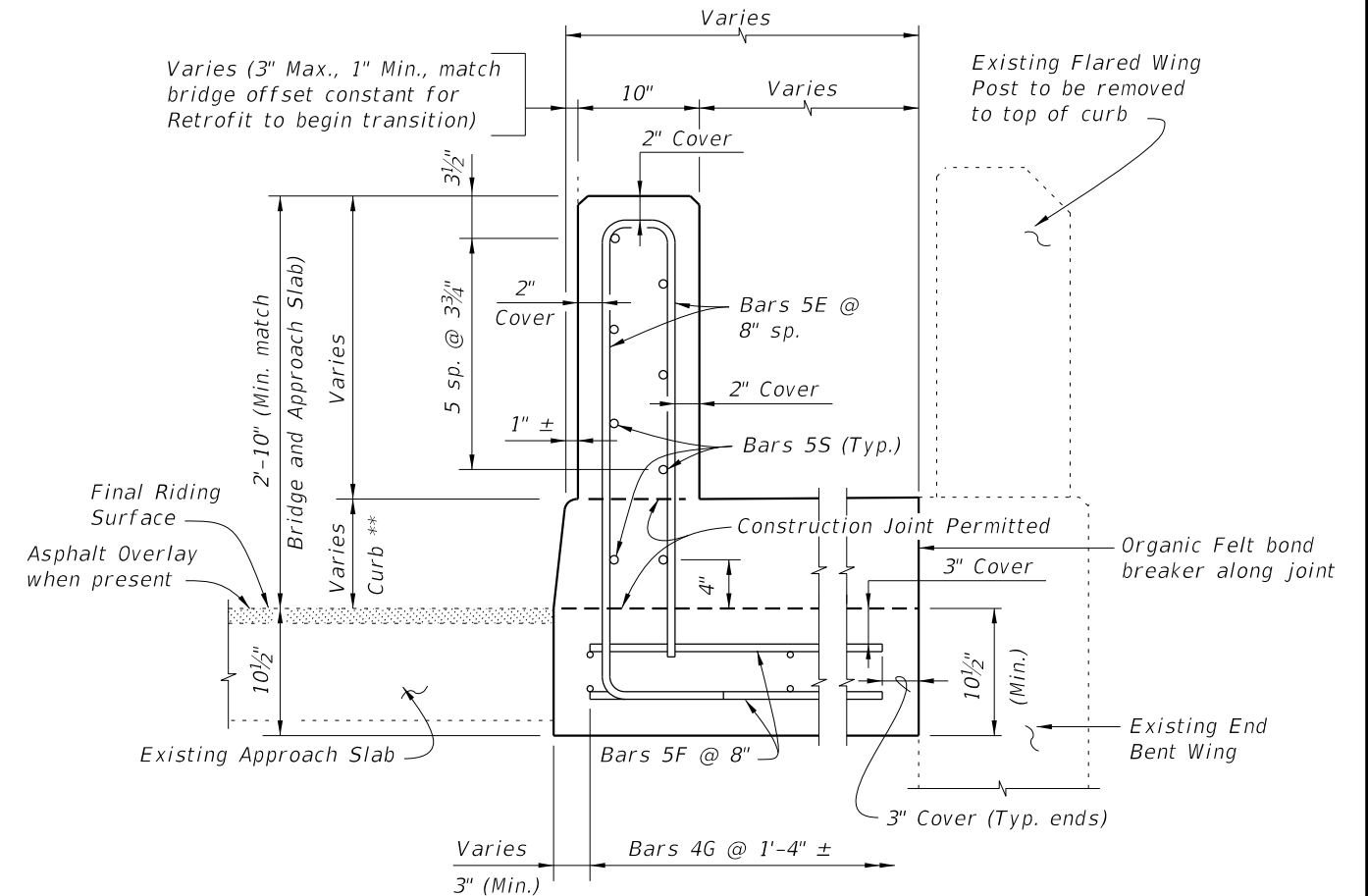

SECTION G-G

Note:
** Match curb height at adjoining existing end bent wing.

CROSS REFERENCES:
For Section A-A see Sheet 4.
For Section D-D see Sheet 5.
For Section F-F see Sheet 6.
For Expansion Dowel Assemblies Details and placement of Dowel Bars 6D see Index 521-480.

LAST REVISION 11/01/16	DESCRIPTION:		FY 2023-24 STANDARD PLANS	TRAFFIC RAILING - (VERTICAL FACE RETROFIT) SPREAD FOOTING APPROACH	INDEX 521-484	SHEET 7 of 10
---------------------------	--------------	--	------------------------------	---	------------------	------------------

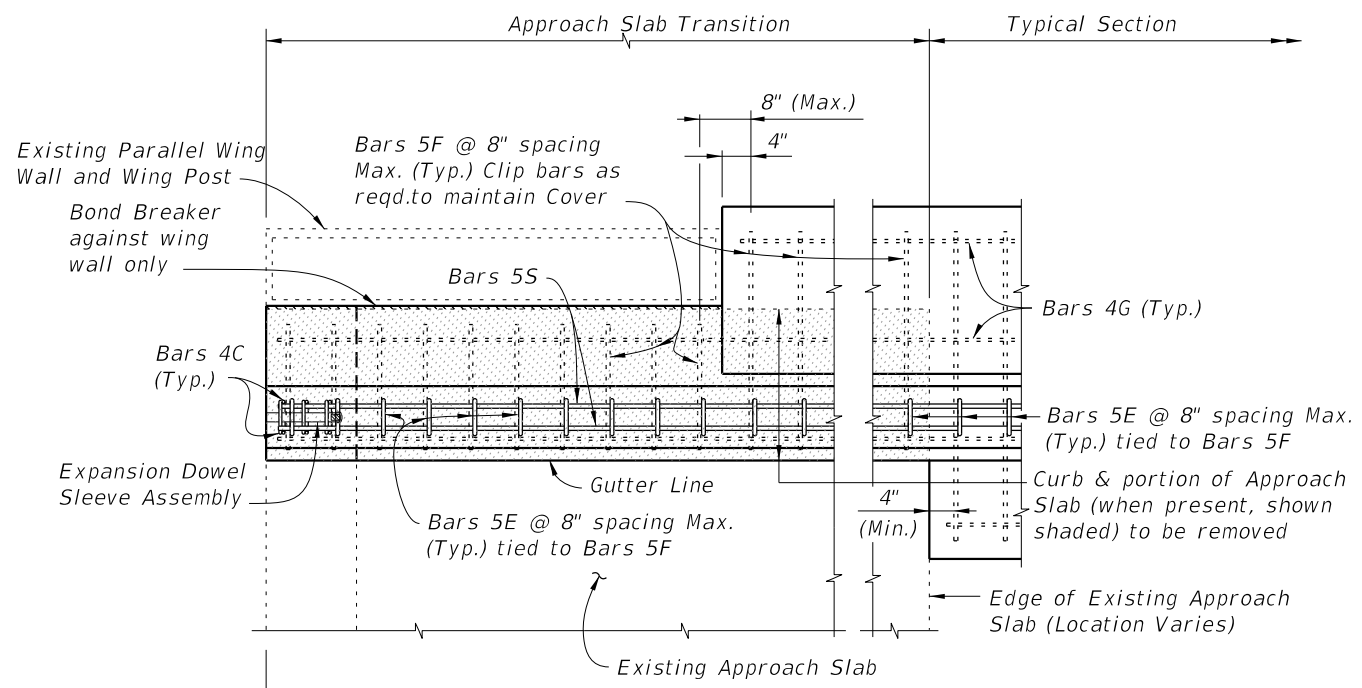

Front Face of Backwall, Begin or End Bridge & Match Line (See Index 521-482, Sheet 2)

PARTIAL PLAN OF RAILING

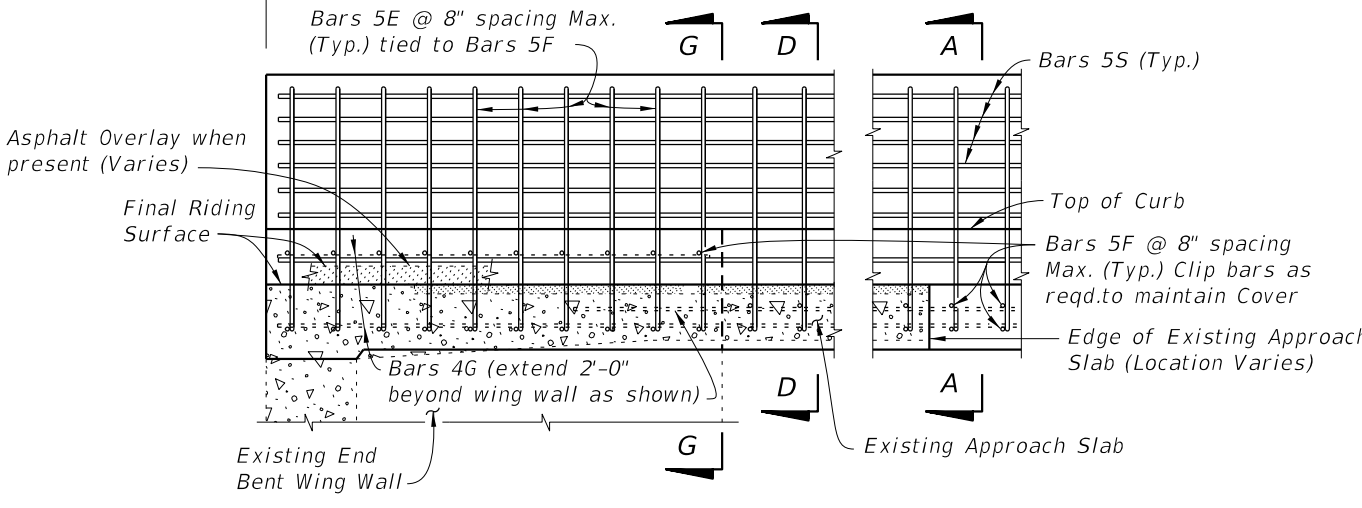

PARTIAL ELEVATION OF INSIDE FACE OF RAILING
(Existing Wing Post, Expansion Dowel Assemblies and Bars 4C not shown for clarity)

SCHEME 4 ~ MODIFICATION FOR INDEX 521-482 SCHEME 2
RAILING END TREATMENT FOR PARALLEL CURBS AND WING WALLS WITH WIDE CURBS

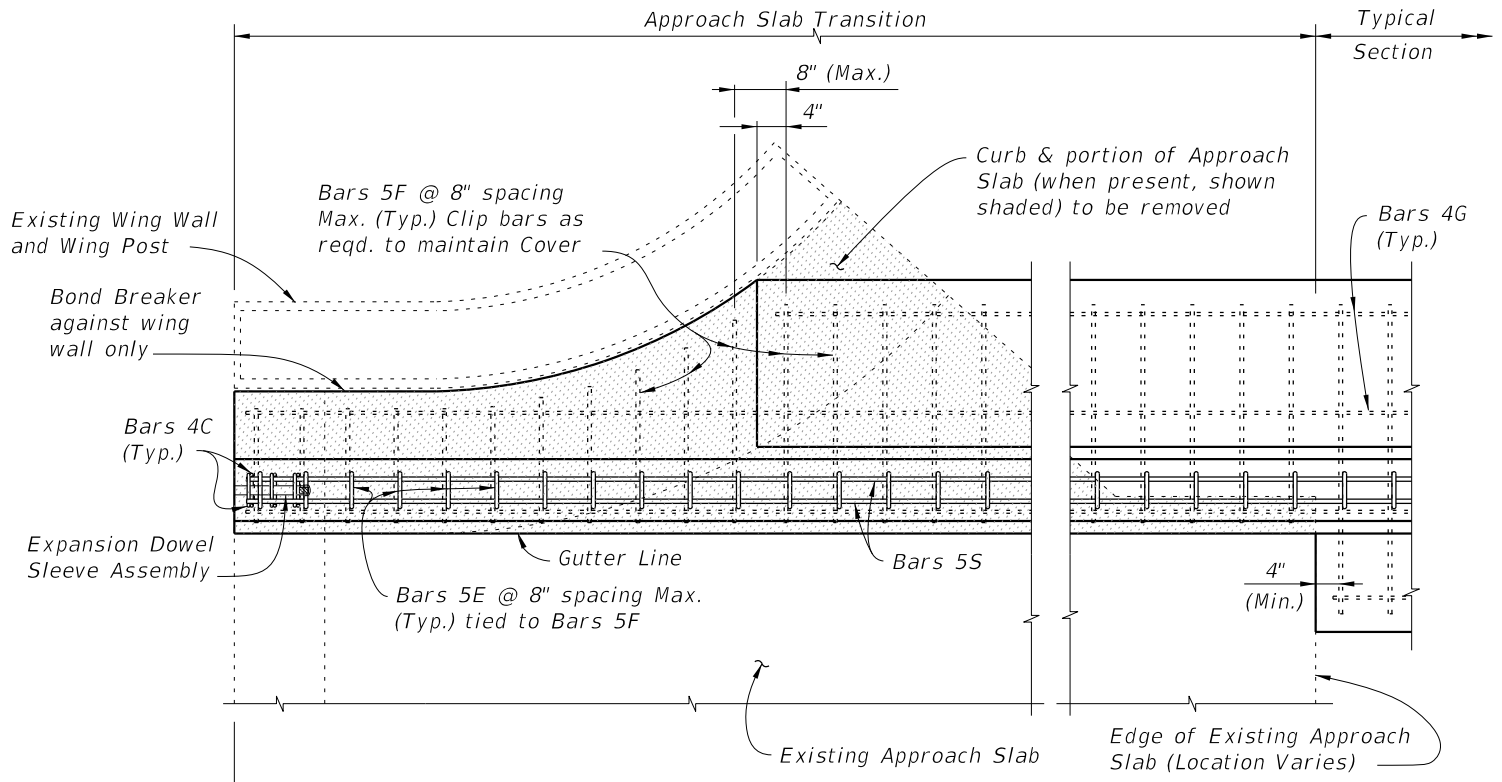

Front Face of Backwall, Begin or End Bridge & Match Line (See Index 521-482, Sheet 3)

PARTIAL PLAN OF RAILING

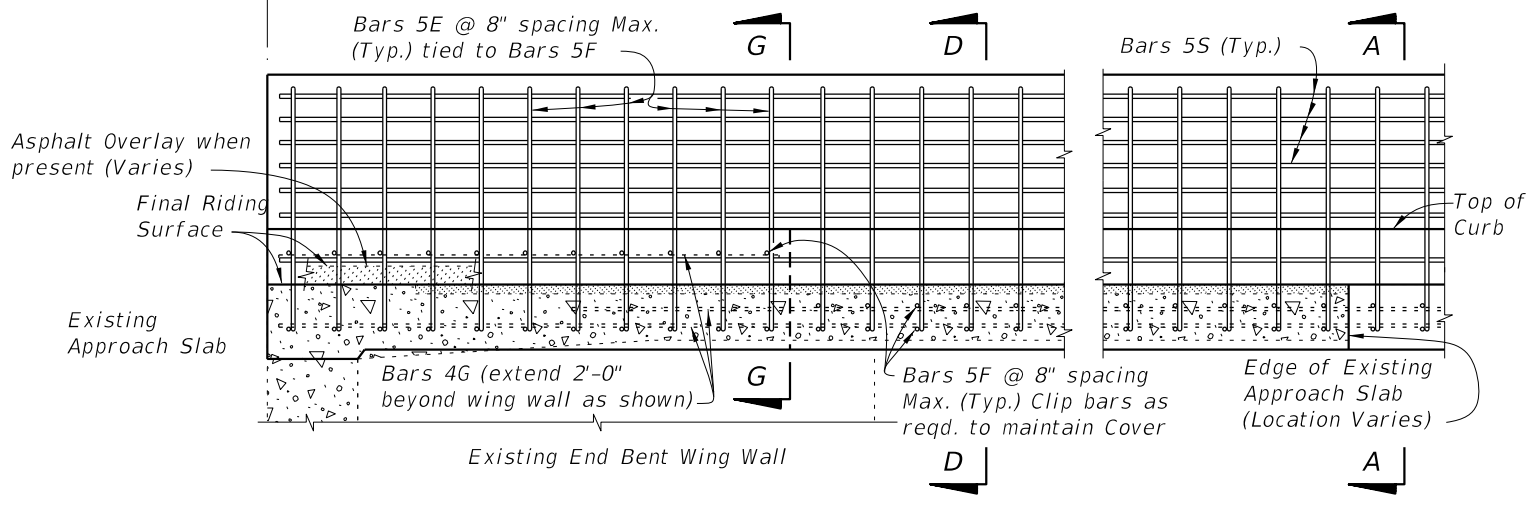

PARTIAL ELEVATION OF INSIDE FACE OF RAILING
(Existing Wing Post, Expansion Dowel Assemblies and Bars 4C not shown for clarity)

SCHEME 5 ~ MODIFICATION FOR INDEX 521-482 SCHEME 3 AND 4
RAILING END TREATMENT FOR PARALLEL CURBS AND FLARED WING WALLS WITH WIDE CURBS

CROSS REFERENCES:
For Section A-A see Sheet 4
For Section D-D see Sheet 5.
For Section G-G see Sheet 7.
For Expansion Dowel Assemblies Details see Index 521-480.

10/6/2022 12:51:33 PM

LAST REVISION 07/01/09	REVISION	DESCRIPTION:		FY 2023-24 STANDARD PLANS	TRAFFIC RAILING - (VERTICAL FACE RETROFIT) SPREAD FOOTING APPROACH	INDEX 521-484	SHEET 8 of 10
---------------------------	----------	--------------	--	--	---	------------------	------------------

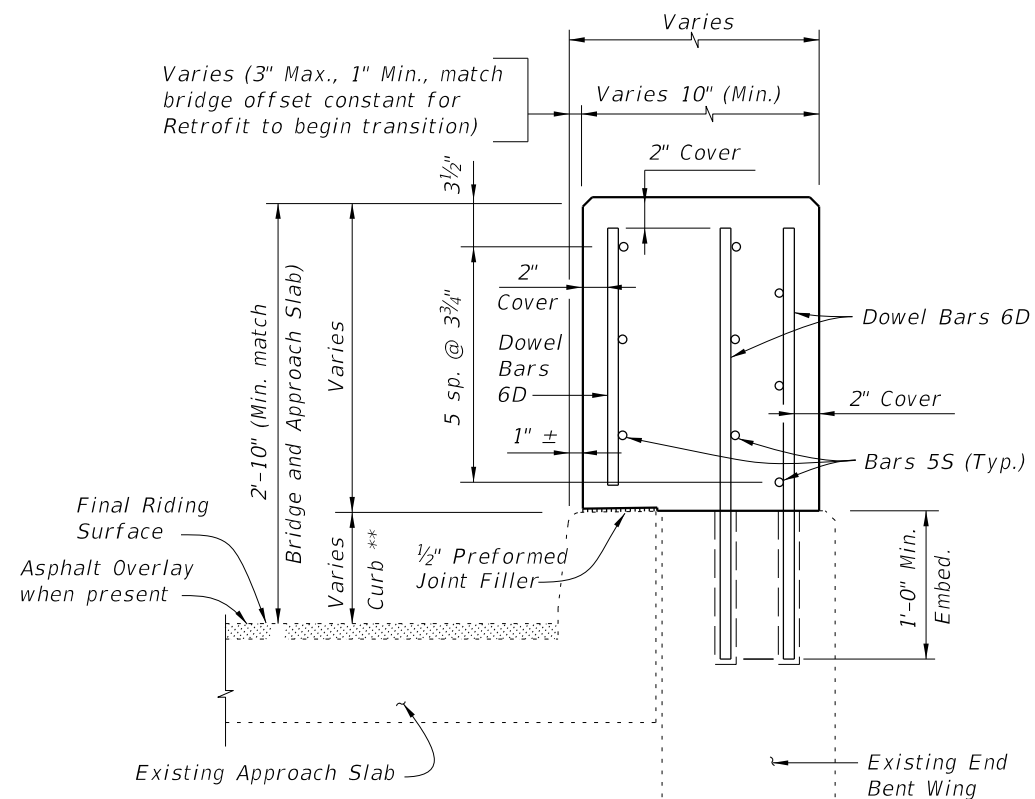
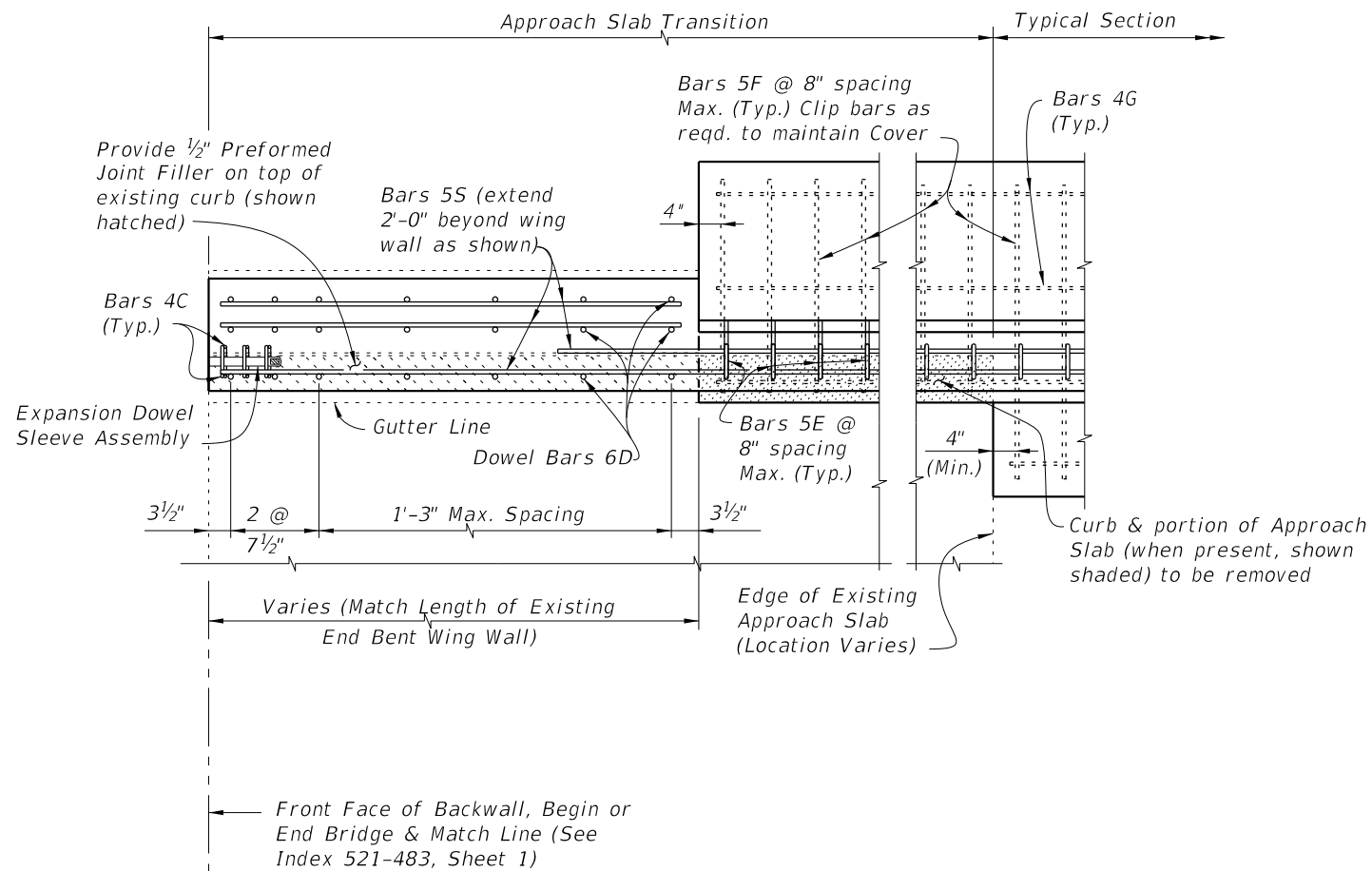

Note:
 ** Match curb height at adjoining existing end bent wing.

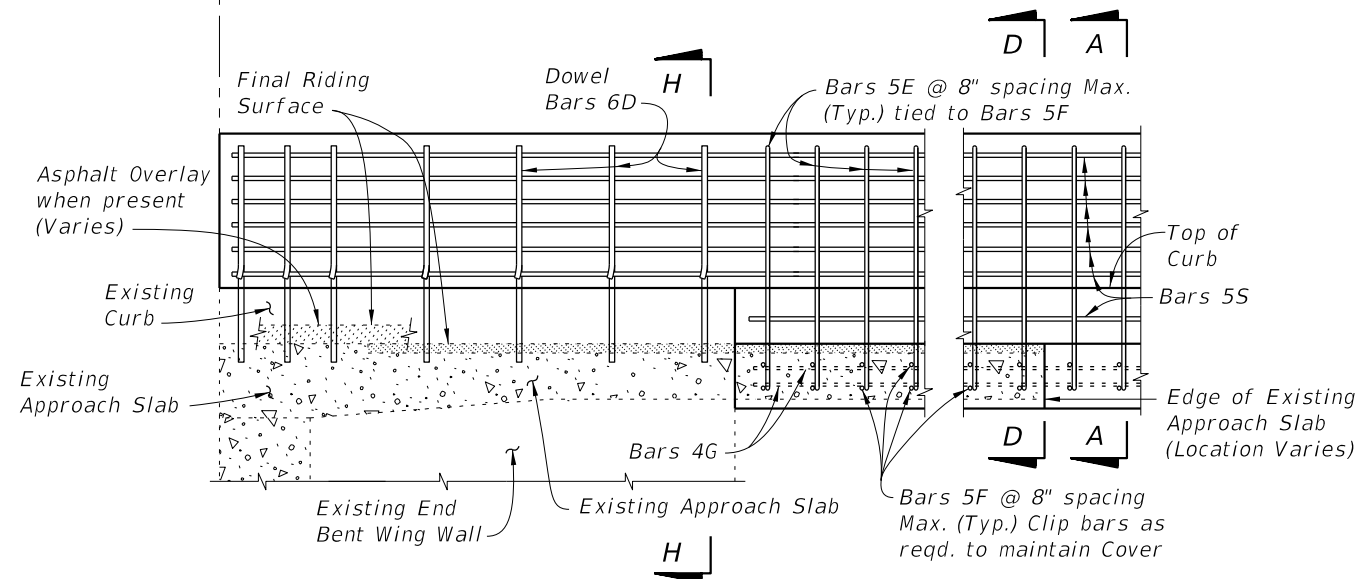

PARTIAL ELEVATION OF INSIDE FACE OF RAILING
 (Expansion Dowel Assemblies and Bars 4C not shown for clarity)

SCHEME 6 ~ MODIFICATION FOR INDEX 521-483 SCHEME 2
RAILING END TREATMENT FOR PARALLEL CURBS AND WING WALLS WITH INTERMEDIATE CURBS

CROSS REFERENCES:
 For Section A-A see Sheet 4.
 For Section D-D see Sheet 5.
 For Expansion Dowel Assembly and placement of Dowel Bars 6D Details see Index 521-480.

10/6/2022 12:51:33 PM

LAST REVISION 07/01/09	REVISION	DESCRIPTION:		FY 2023-24 STANDARD PLANS	TRAFFIC RAILING - (VERTICAL FACE RETROFIT) SPREAD FOOTING APPROACH	INDEX 521-484	SHEET 9 of 10
---------------------------	----------	--------------	--	------------------------------	---	-------------------------	-------------------------

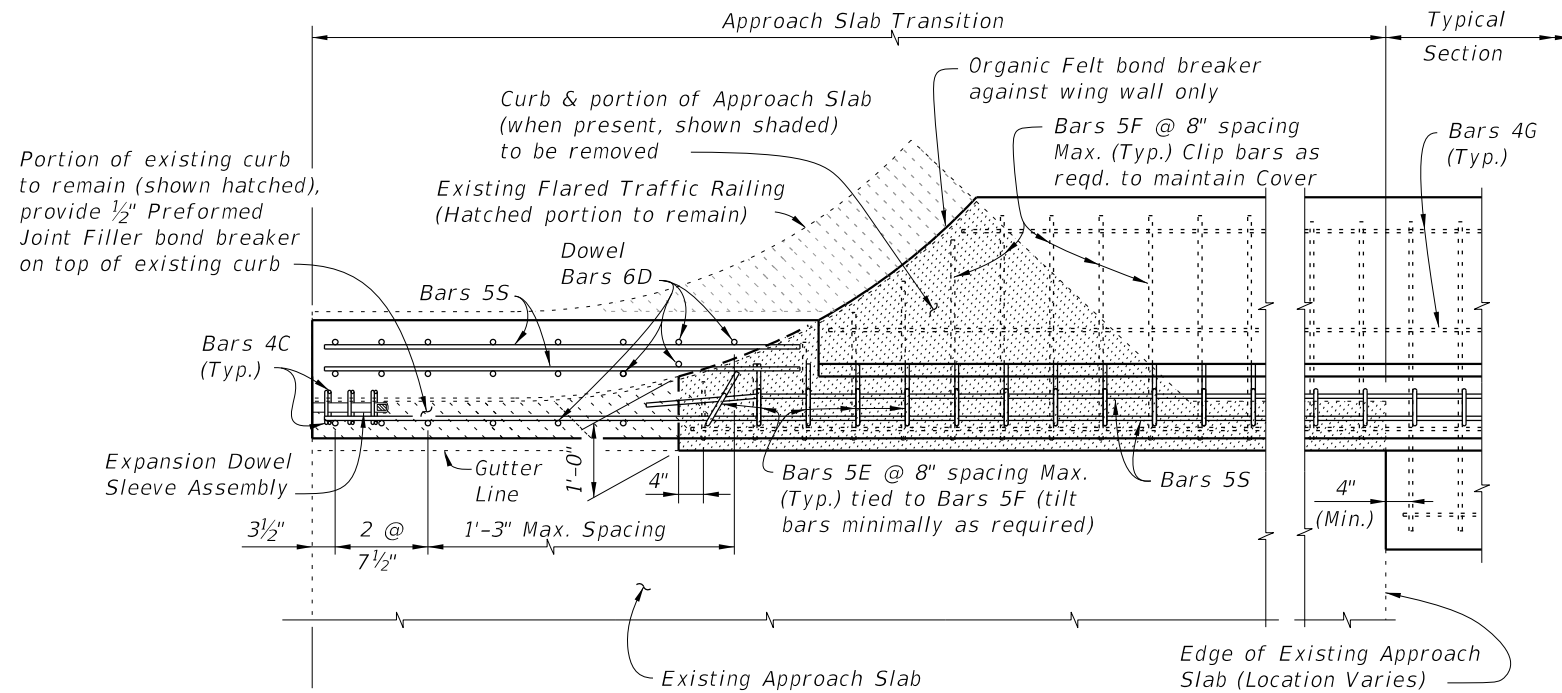

PARTIAL PLAN OF RAILING

Front Face of Backwall, Begin or End Bridge & Match Line (See Index 521-483, Sheet 3)

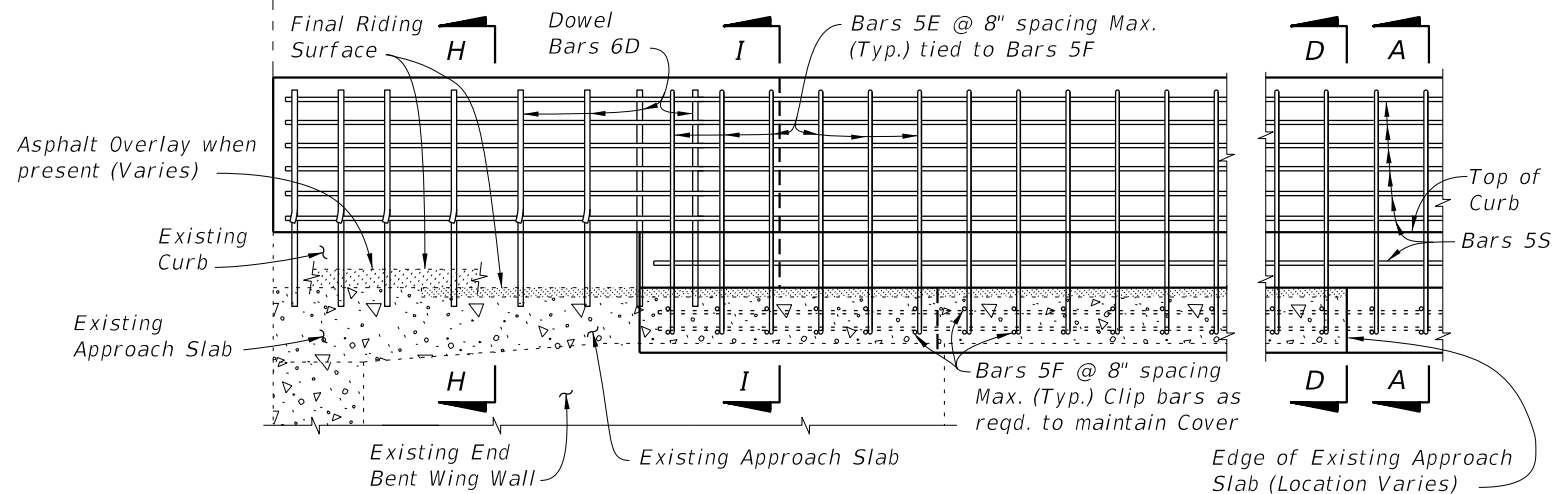

PARTIAL ELEVATION OF INSIDE FACE OF RAILING
(Expansion Dowel Assemblies and Bars 4C not shown for clarity)

SCHEME 7 ~ MODIFICATION FOR INDEX 521-483 SCHEME 3
RAILING END TREATMENT FOR PARALLEL CURBS AND
FLARED WING WALLS WITH INTERMEDIATE CURBS

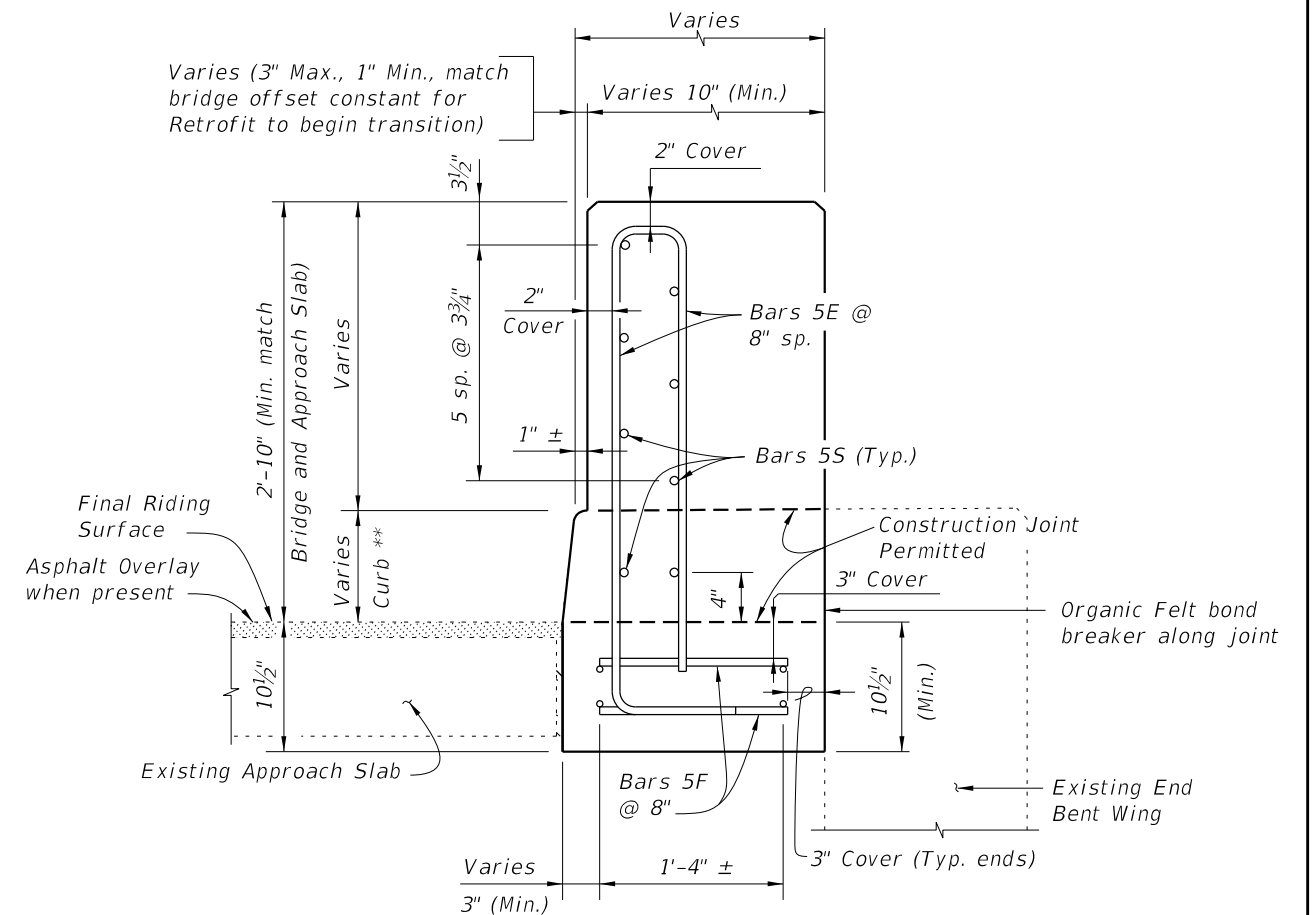

SECTION I-I

Note:
** Match curb height at adjoining existing end bent wing.

CROSS REFERENCES:
For Section A-A see Sheet 4.
For Section D-D see Sheet 5.
For Section H-H see Sheet 9.
For Expansion Dowel Assemblies and placement of Dowel Bars 6D Details see Index 521-480.

10/6/2022 12:51:34 PM

LAST REVISION 11/01/16	DESCRIPTION:		FY 2023-24 STANDARD PLANS	TRAFFIC RAILING - (VERTICAL FACE RETROFIT) SPREAD FOOTING APPROACH	INDEX 521-484	SHEET 10 of 10
---------------------------	--------------	---	------------------------------	---	------------------	-------------------