

ELEVATION

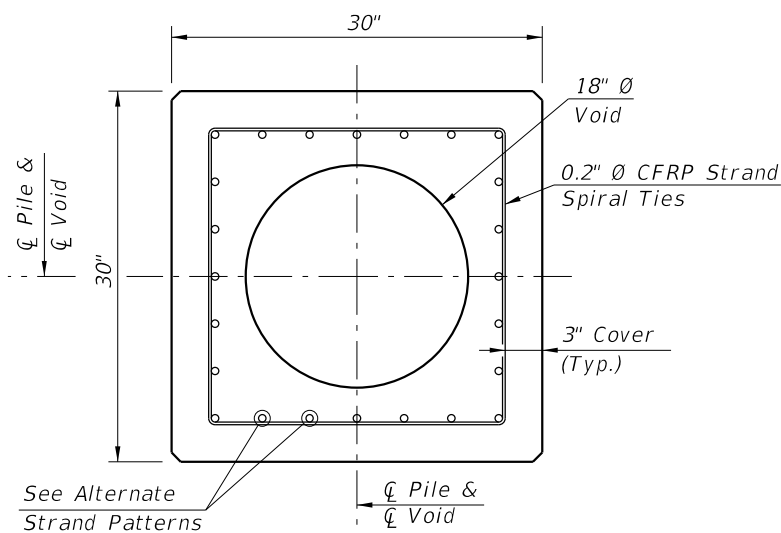

SECTION B-B
(See Pile Splice Reinforcement Details)

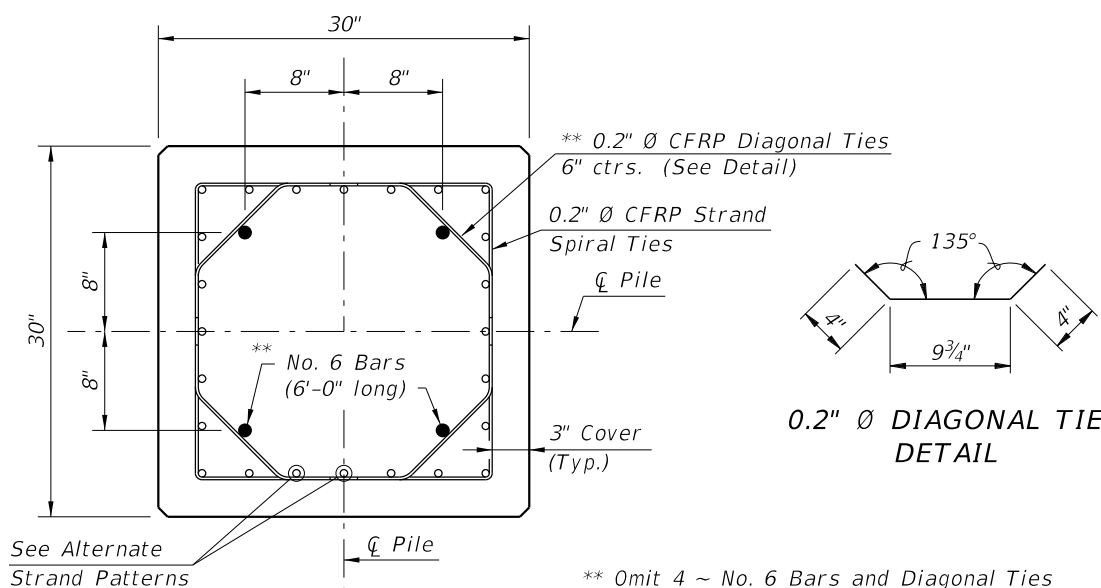

SECTION C-C
(See Pile Splice Reinforcement Details)

** Omit 4 ~ No. 6 Bars and Diagonal Ties in pre-planned mechanical splice.

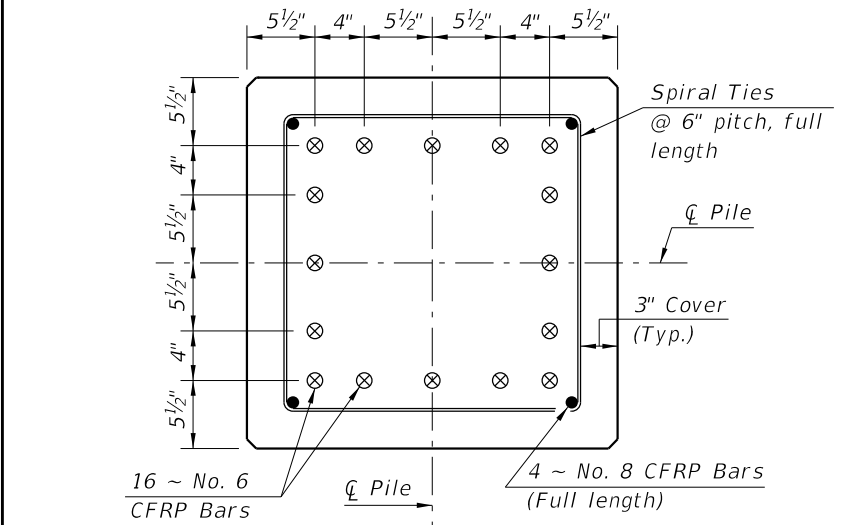

SECTION D-D
(See Non-Drivable Unforeseen Reinforced Precast Pile Build-Up Detail)

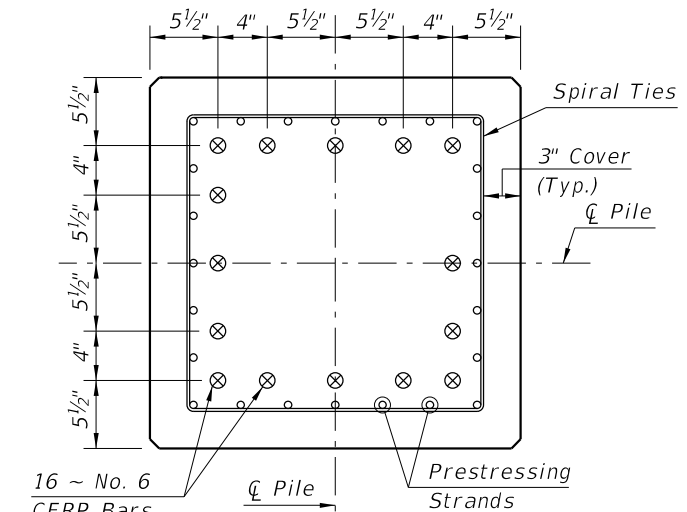

SECTION E-E
(See Drivable Prestressed Precast Pile Splice Detail)

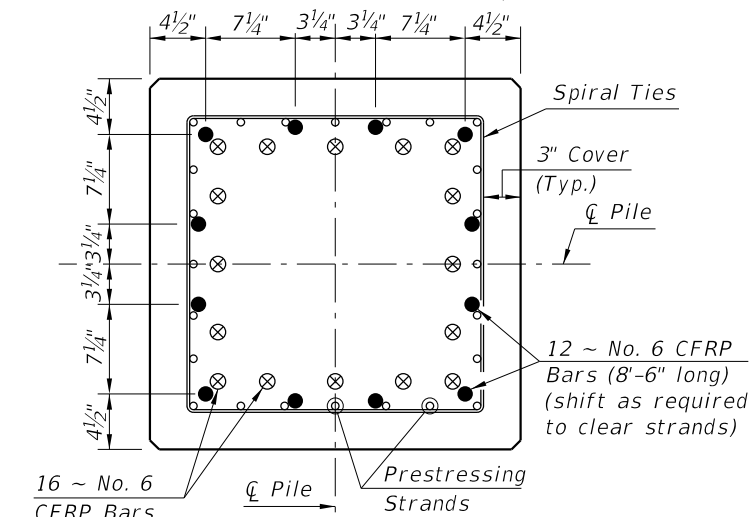

SECTION F-F
(See Drivable Preplanned Prestressed Precast Pile Splice Detail)

CFRP PILE SPLICE DETAILS

ALTERNATE STRAND PATTERNS

- 20 ~ 0.6" Ø, CFRP 7-Strand at 38 kips
- 20 ~ 1/2" Ø, CFRP Single-Strand at 37 kips

NOTES:

- Any of the given Strand Patterns may be utilized. The strands shall be located as follows: Place one strand at each corner and place the remaining strands equally spaced between the corner strands. The total strand pattern shall be concentric with the nominal concrete section of the pile.
- CONTRACTOR OPTION: The 30" pile may be cast SOLID by omitting the 18" Ø void. In this event, the Contractor shall submit calculations for approval and a proposed strand configuration that provide net prestressing after losses equal to 1000 psi. Alternate configurations for the Diagonal Ties, to maintain the position of the 4 ~ #6 Bars, may be approved by the Engineer.
- Work this Index with Index 455-101 - Typical Details and Notes for Square CFRP & SS Prestressed Concrete Piles and Index 455-102 - Square CFRP & SS Prestressed Concrete Pile Splices.

CFRP PRESTRESSED PILE DETAILS

10/6/2022 11:09:08 AM

LAST REVISION 11/01/16	REVISION	DESCRIPTION:		FY 2023-24 STANDARD PLANS	30" SQUARE CFRP & SS PRESTRESSED CONCRETE PILE	INDEX 455-130	SHEET 1 of 2
---------------------------	----------	--------------	--	------------------------------	---	------------------	-----------------

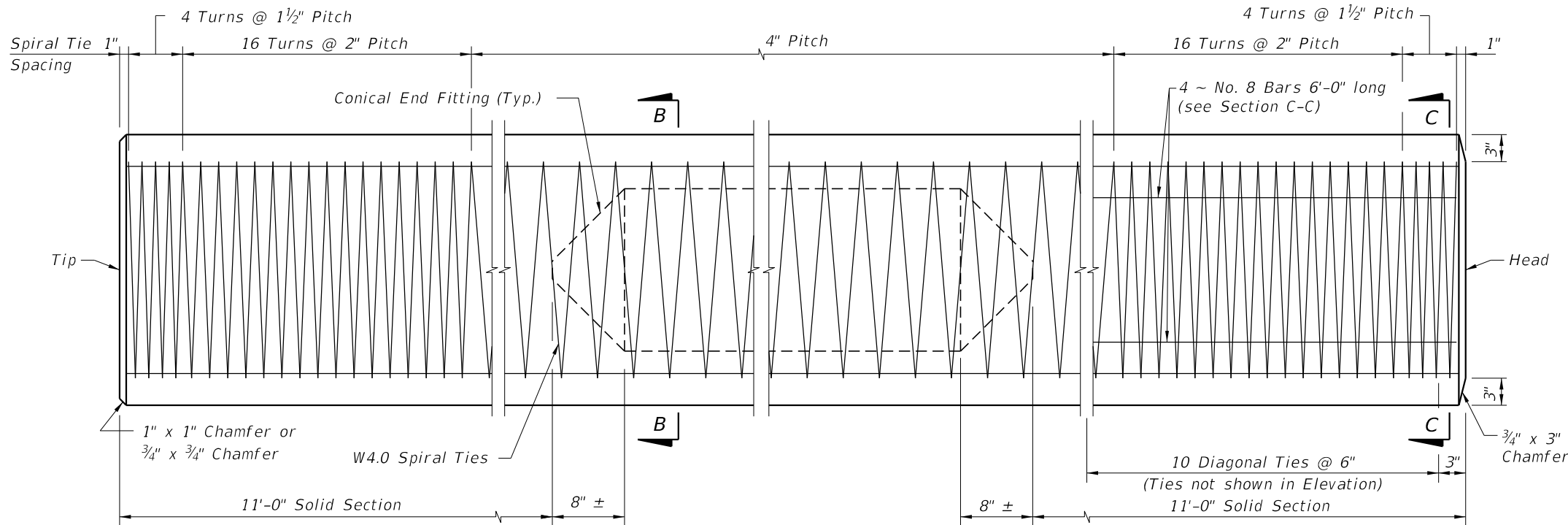

ELEVATION

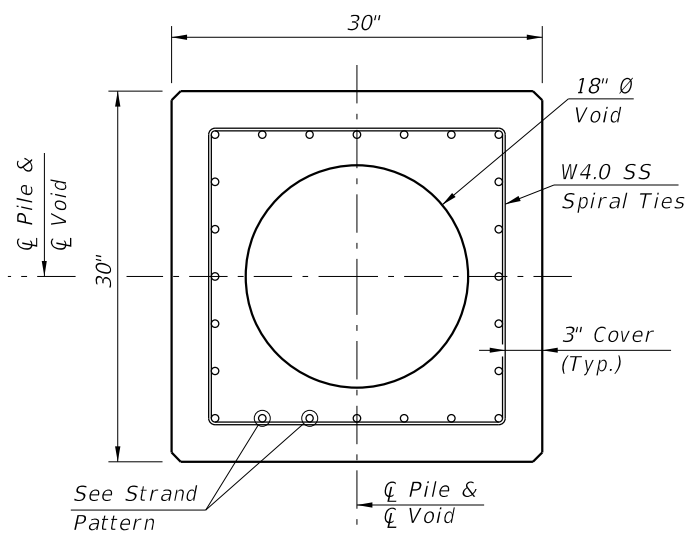

SECTION B-B
(See Pile Splice Reinforcement Details)

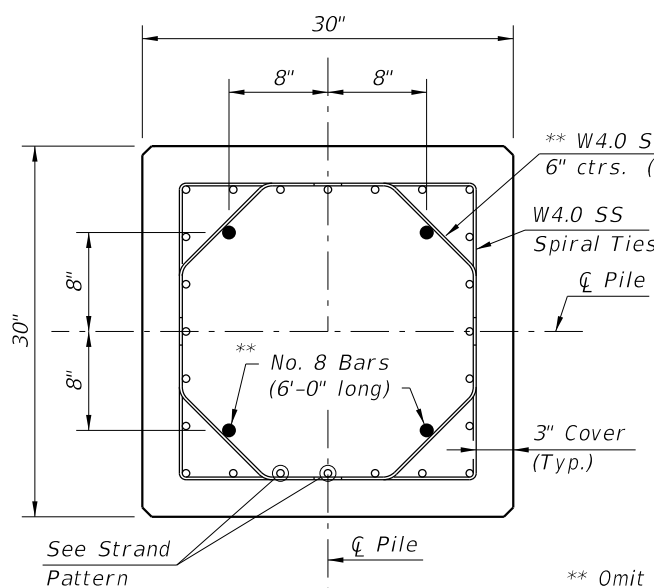

SECTION C-C
(See Pile Splice Reinforcement Details)

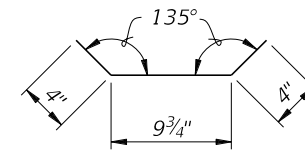

W4.0 DIAGONAL TIE
DETAIL

** Omit 4 ~ No. 8 Bars and Diagonal Ties in pre-planned mechanical splice.

NOTES:

- Any of the given Strand Patterns may be utilized. The strands shall be located as follows: Place one strand at each corner and place the remaining strands equally spaced between the corner strands. The total strand pattern shall be concentric with the nominal concrete section of the pile.
- CONTRACTOR OPTION: The 30" pile may be cast SOLID by omitting the 18" Ø void. In this event, the Contractor shall submit calculations for approval and a proposed strand configuration that provide net prestressing after losses equal to 1000 psi. Alternate configurations for the Diagonal Ties, to maintain the position of the 4 ~ #8 Bars, may be approved by the Engineer.
- Work this Index with Index 455-101 - Typical Details and Notes for Square CFRP & SS Prestressed Concrete Piles and Index 455-102 - Square CFRP & SS Prestressed Concrete Pile Splices.

STRAND PATTERN

- 32 ~ 1/2" Ø, HSSS at 26 kips
- 24 ~ 0.6" Ø, HSSS at 35 kips

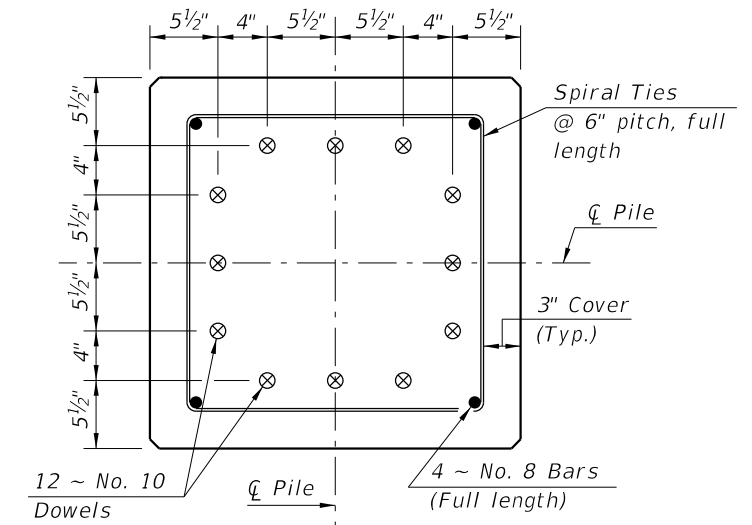

SECTION D-D
(See Non-Drivable Unforeseen Reinforced Precast Pile Build-Up Detail)

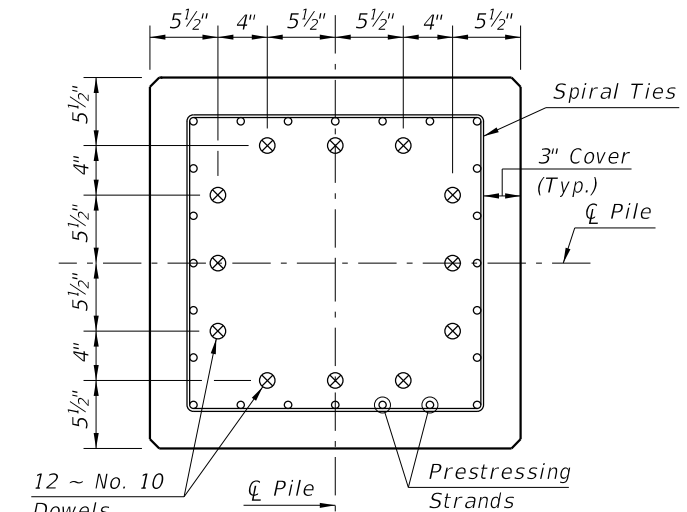

SECTION E-E
(See Drivable Prestressed Precast Pile Splice Detail)

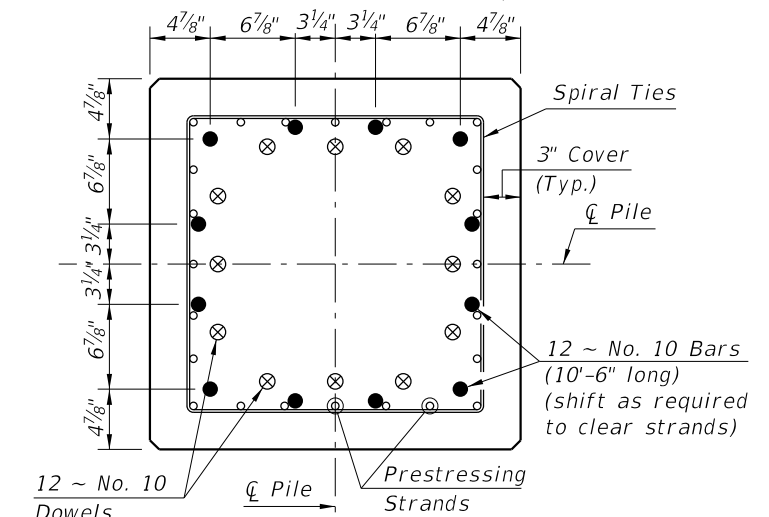

SECTION F-F
(See Drivable Preplanned Prestressed Precast Pile Splice Detail)

SS PILE SPLICE DETAILS

SS PRESTRESSED PILE DETAILS

10/6/2022 11:09:08 AM

LAST REVISION 11/01/20	REVISION	DESCRIPTION:		FY 2023-24 STANDARD PLANS	30" SQUARE CFRP & SS PRESTRESSED CONCRETE PILE	INDEX 455-130	SHEET 2 of 2
---------------------------	----------	--------------	--	------------------------------	---	------------------	-----------------