

END VIEW AT END DIAPHRAGM

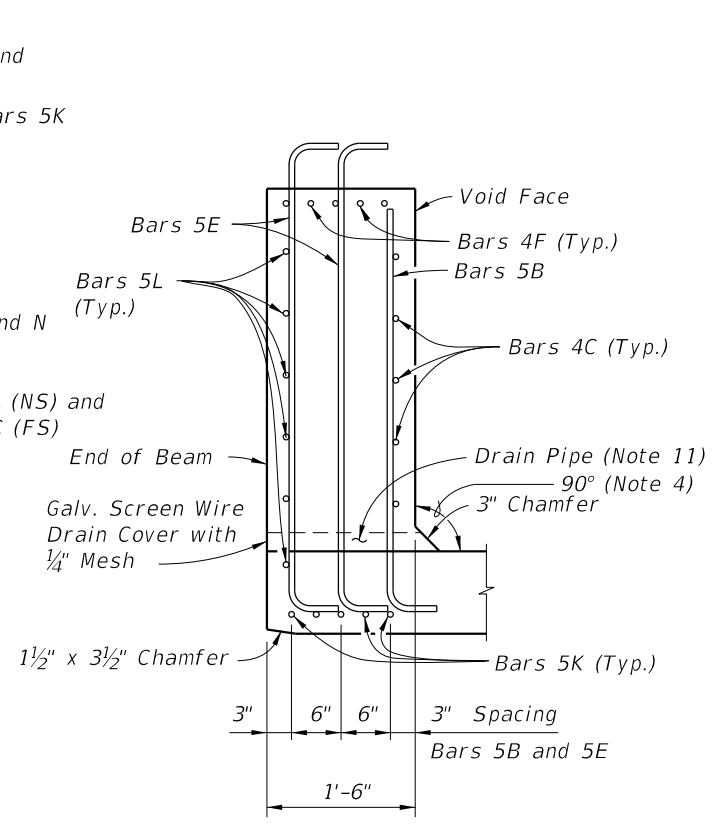

SECTION C-C

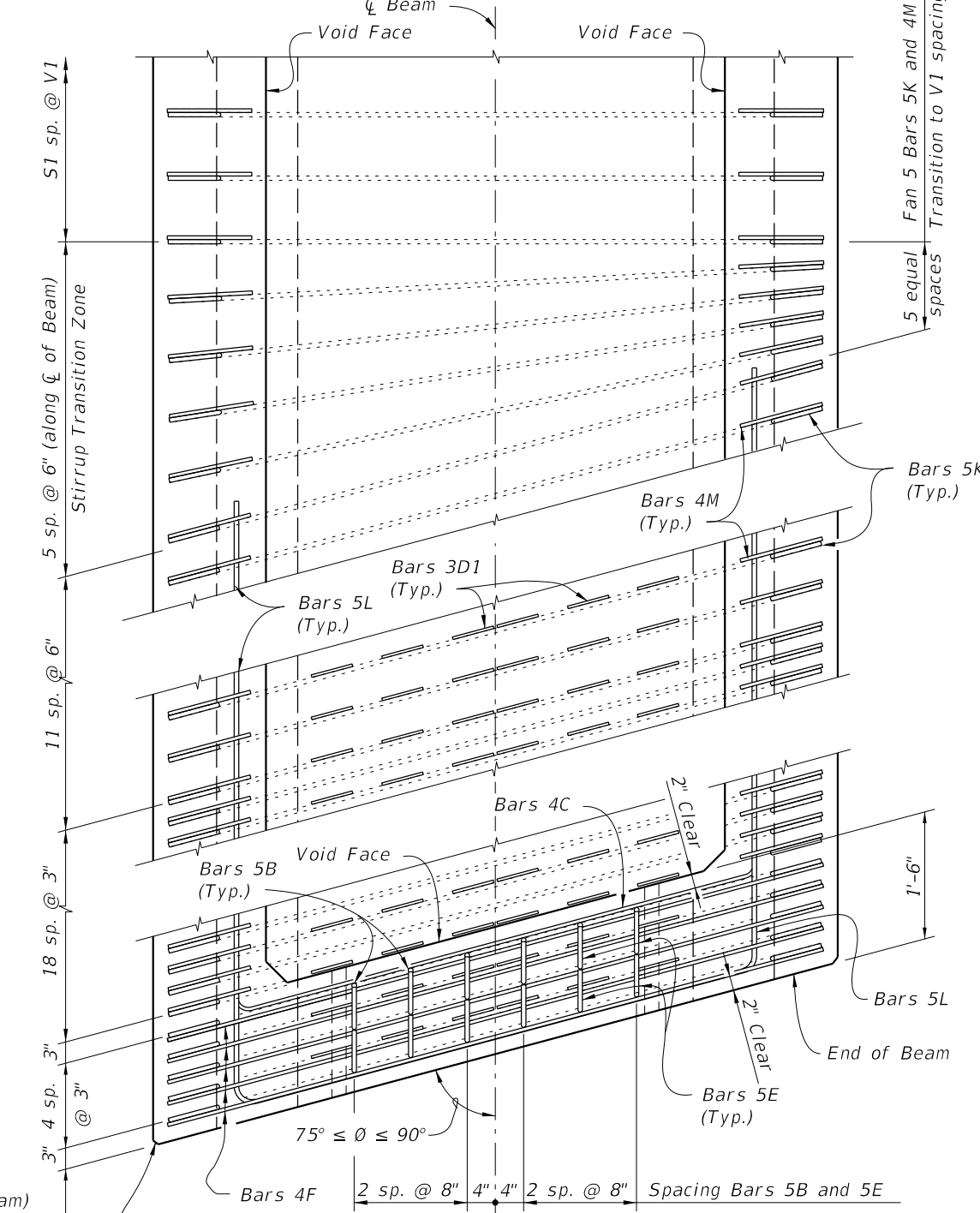

TOP VIEW OF SKEWED END DIAPHRAGM AND STIRRUP TRANSITION ZONE (Bars 3D2 Not Shown For Clarity)

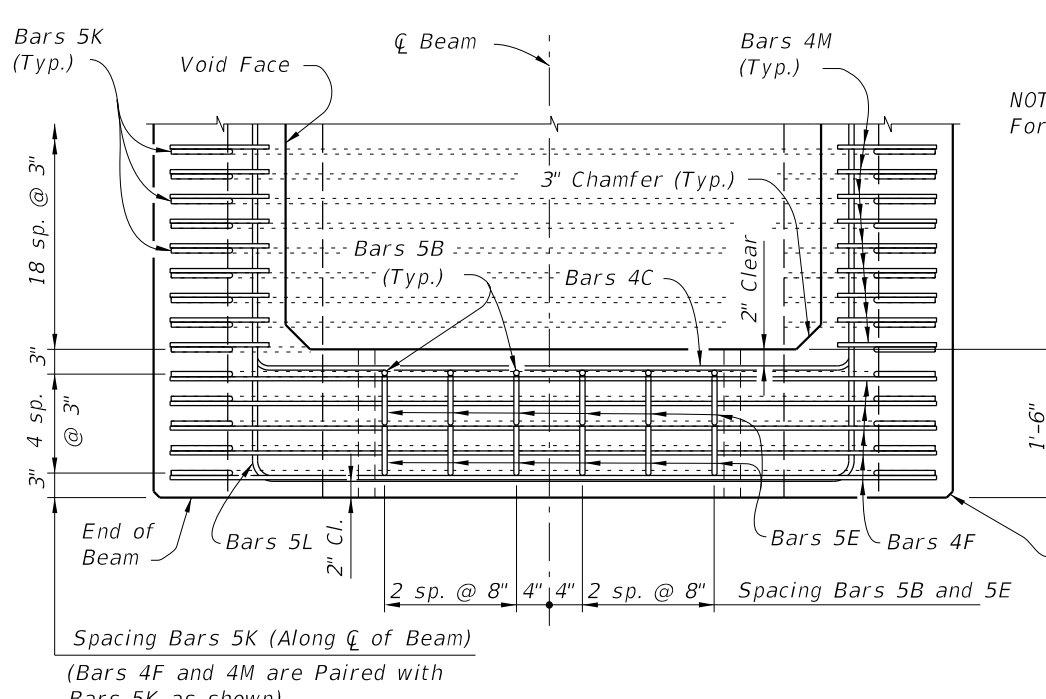

TOP VIEW OF END DIAPHRAGM (Bars 3D1 And 3D2 Not Shown For Clarity)

NOTES:
For referenced notes see Index 450-210.

Spacing Bars 5K (Along ϕ of Beam)
(Bars 4F and 4M are Paired with Bars 5K as shown)

3/4" Chamfer along the Vertical Face of the Top Flange and Web and Underside of the Top Flange (Typ.)

10/16/2022 10:59:07 AM

LAST REVISION 11/01/16	REVISION	DESCRIPTION:		FY 2023-24 STANDARD PLANS	FLORIDA-U 54 BEAM - STANDARD DETAILS	INDEX 450-254	SHEET 2 of 3
---------------------------	----------	--------------	--	------------------------------	--------------------------------------	------------------	-----------------

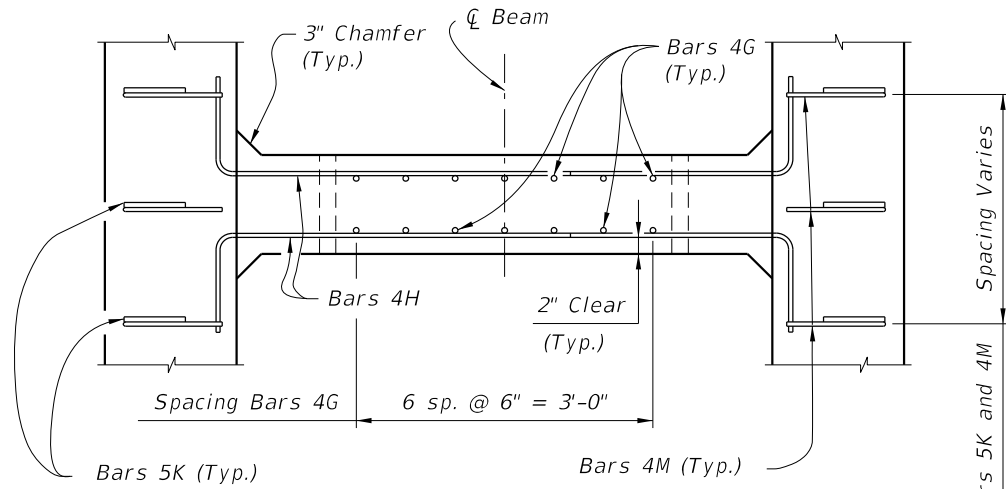

TOP VIEW OF INTERMEDIATE DIAPHRAGM

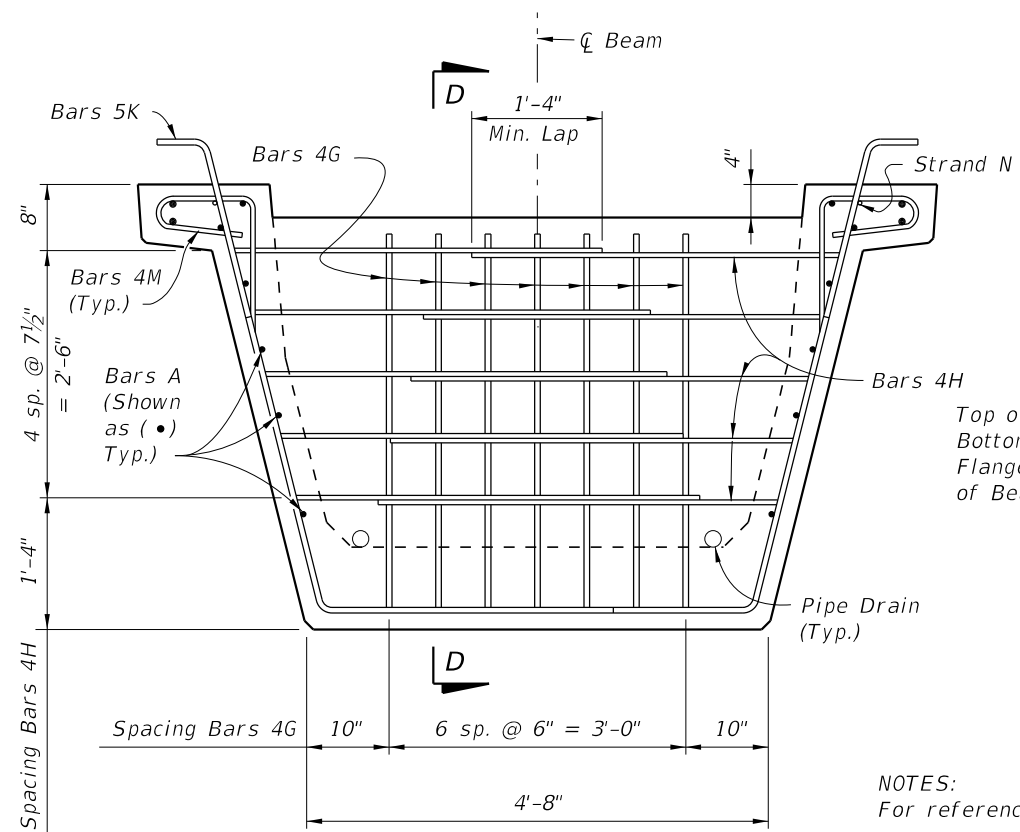

SECTION AT INTERMEDIATE DIAPHRAGM

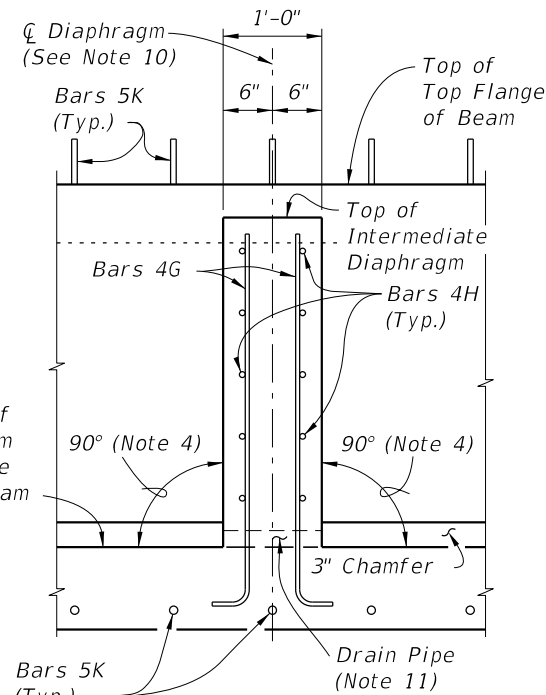

SECTION D-D

NOTES:
 For referenced note see Index 450-210.

CONVENTIONAL REINFORCING STEEL BENDING DIAGRAMS

BILL OF REINFORCING STEEL FOR ONE BEAM ONLY

MARK	SIZE	NO. REQD.	LENGTH
A1	6	4	Dim. L - 4"
A2	4	12	Dim. L - 4"
B	5	12	4'-7"
C	4	20	5'-3"
D1	3	180	1'-6"
D2	3	30	4'-6"
E	5	24	5'-9"
F	4	20	6'-4"
G	4	See Table	4'-6"
H	4	See Table	4'-9"
K	5	See Table	8'-6"
L	5	24	16'-2"
M	4	See Table	3'-11"
N	3/8" ϕ Strand	2	Dim. L - 3"

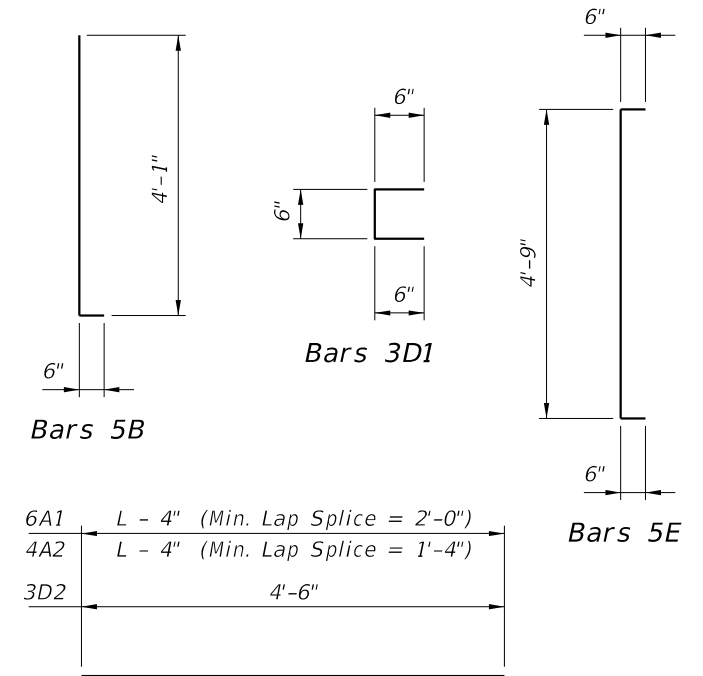

Bars 6A1, 4A2 and 3D2

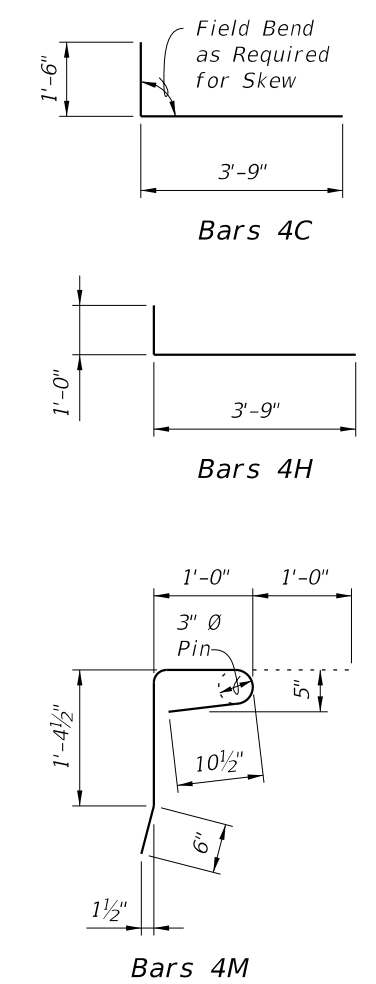
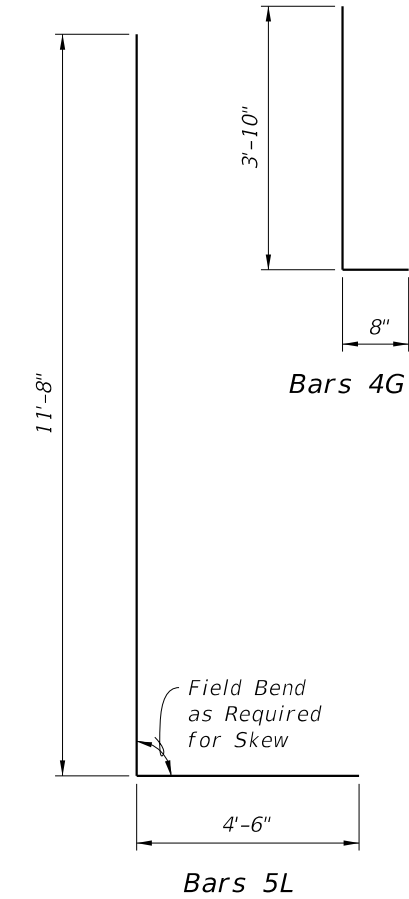
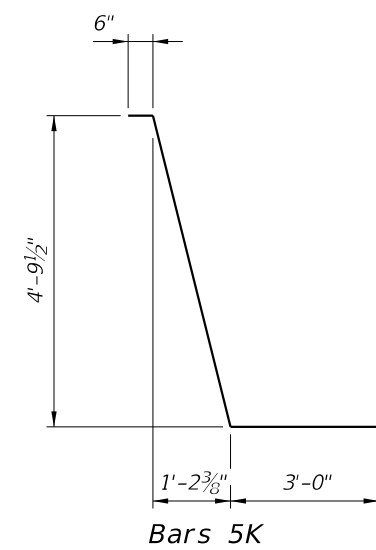
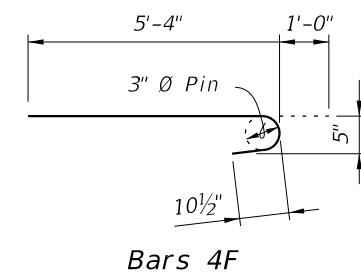

10/16/2022 10:59:08 AM

LAST REVISION 11/01/16	DESCRIPTION:
---------------------------	--------------