

GENERAL NOTES:

1. Work this Index with Index 425-001 and Index 425-010.
2. Orient grate with vanes directed toward predominant flow.
3. Provide 1¼" minimum cover for steel in slab tops unless otherwise shown. Tops may be either cast-in-place or precast concrete.
4. Place top slab openings such that 2 edges of inlet frame will be located directly above bottom wall or riser wall for Alternate B applications..
5. When used on a structure with dimensions larger than those detailed on Sheet 3 and risers are not applied, construct the top slab using Index 425-010 with the slab opening adjusted to 24"x36". The "Special Top Slab" on Index 425-010 is not permitted.
6. Frame may be adjusted with one to six courses of brick.
7. Vaned grates with approximately equal openings that satisfy AASHTO HL-93 loading are permitted. Provide reversible (right or left) grates.

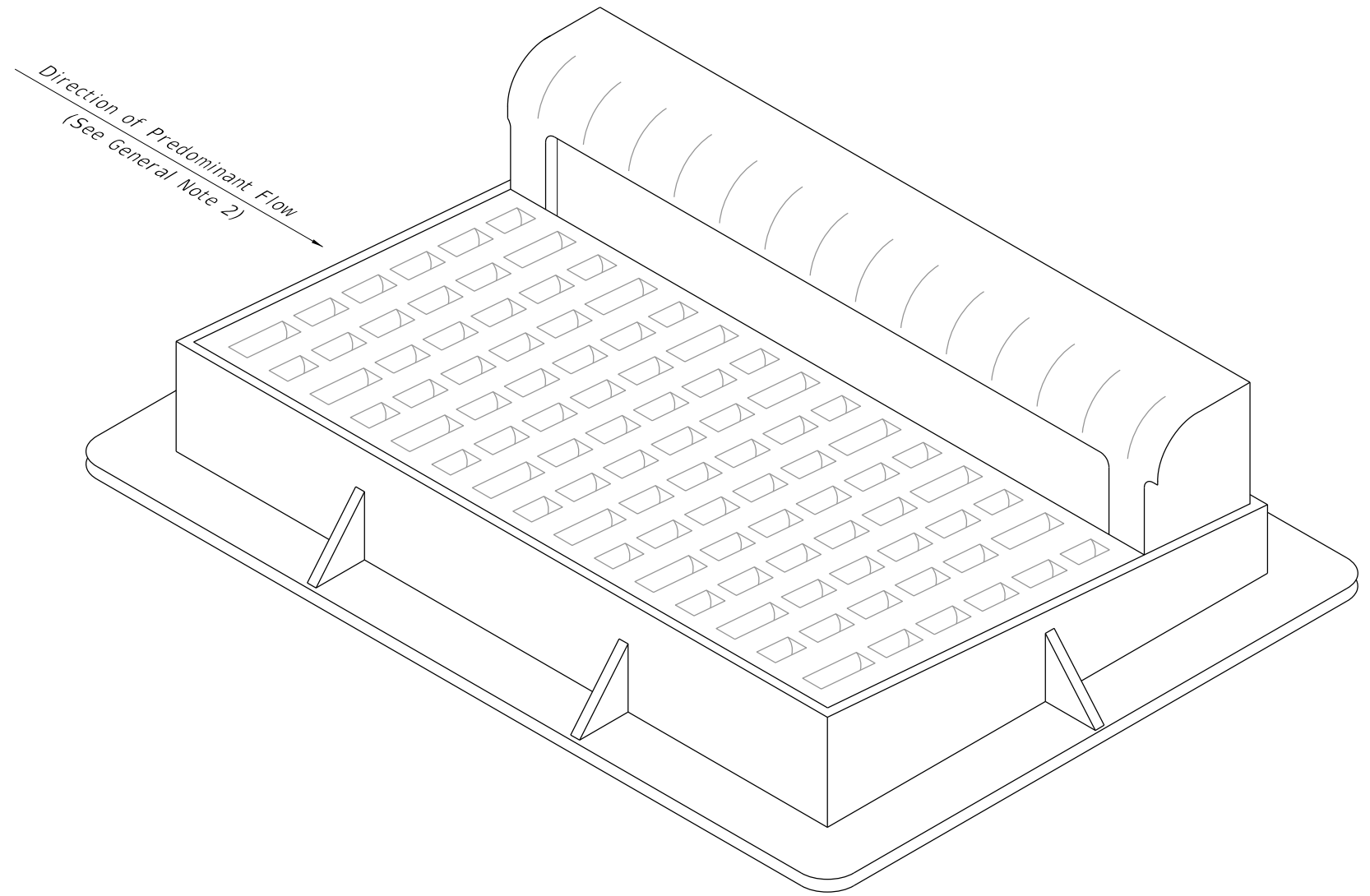
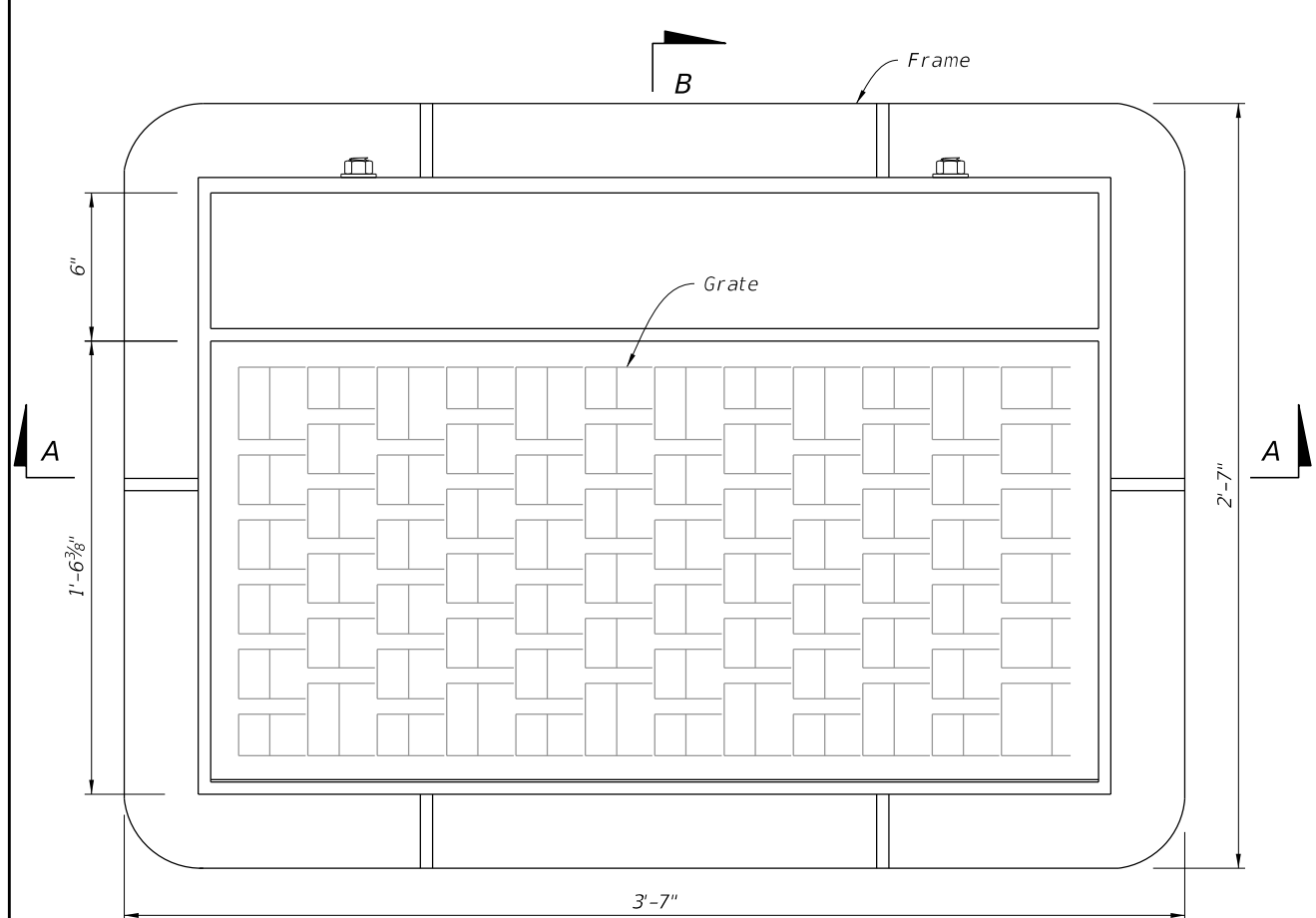

TABLE OF CONTENTS:	
Sheet	Description
1	General Notes and Contents
2	Frame and Grate Details
3	Top Slab Details

=====**CURB INLET TOP TYPE 9**=====

10/6/2022 1:45:27 PM



PLAN

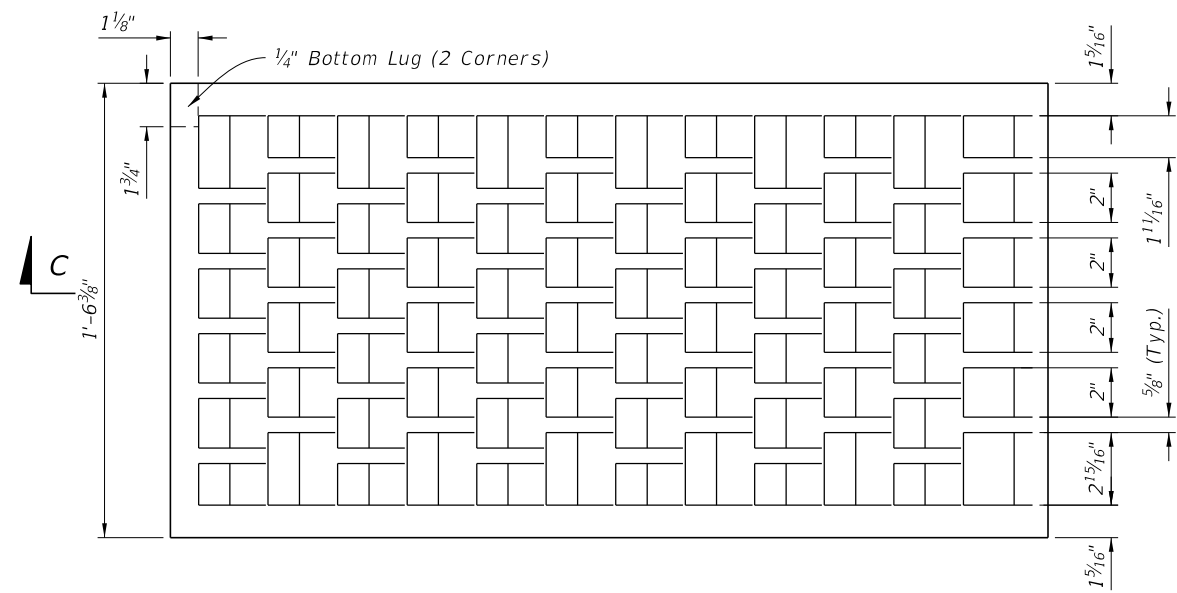

PLAN

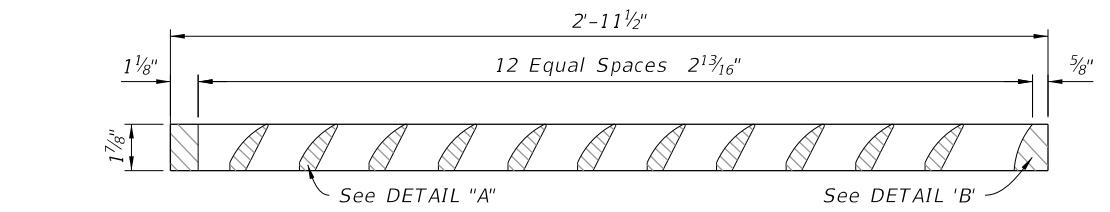

SECTION C-C

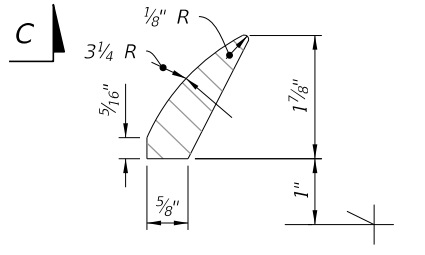

DETAIL "A"

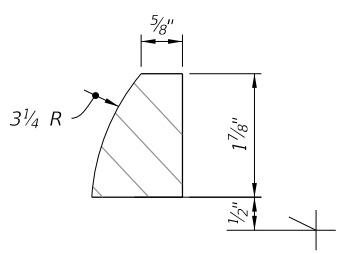

DETAIL "B"

GRATE DETAILS

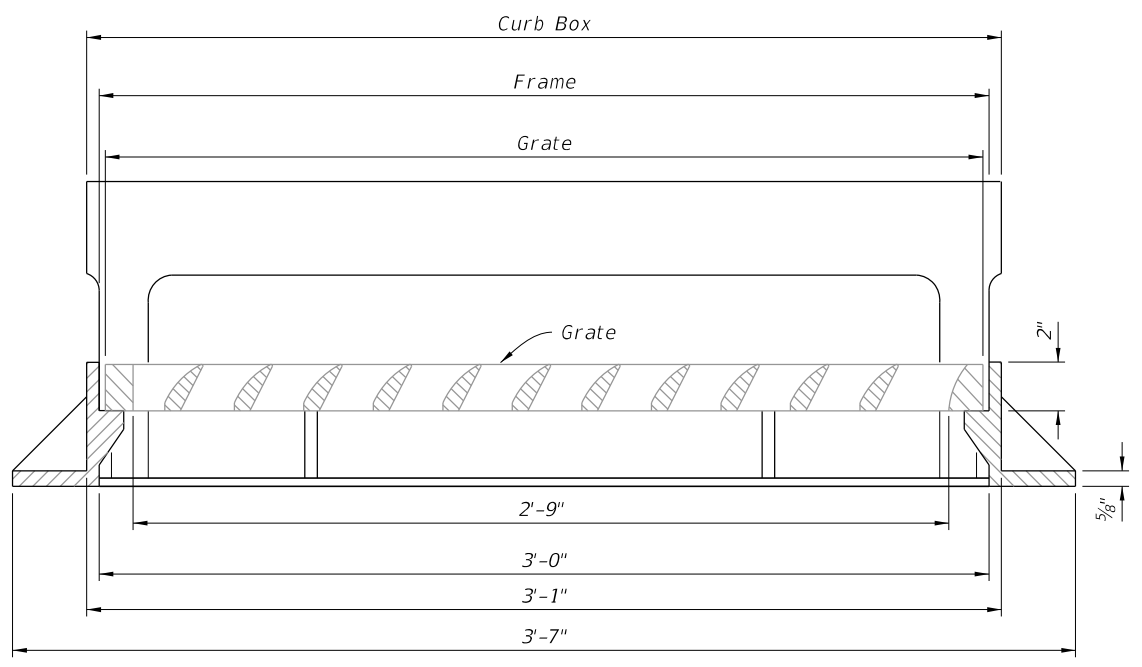

SECTION A-A

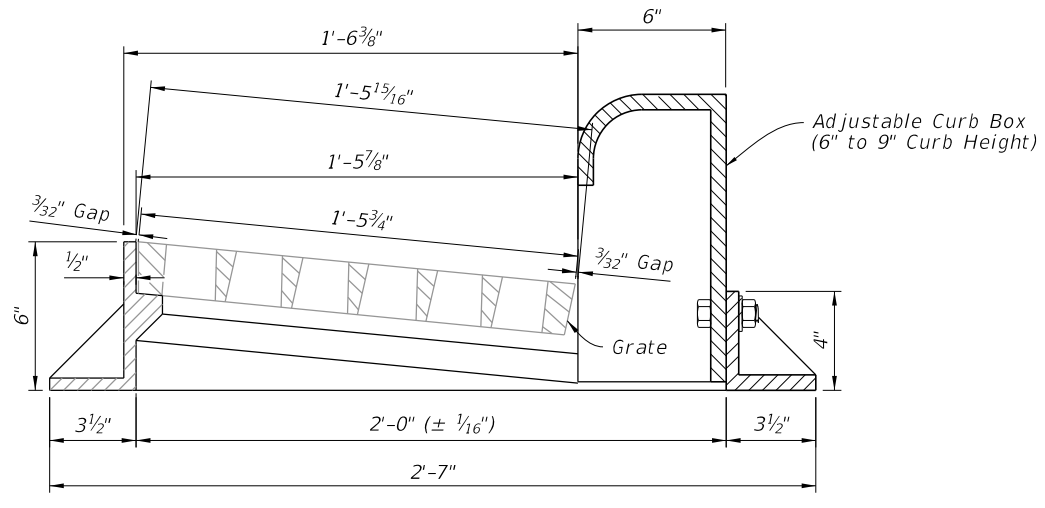

SECTION B-B

FRAME AND GRATE DETAILS

FRAME AND GRATE DETAILS

10/6/2022 1:45:27 PM

LAST REVISION 10/01/20	DESCRIPTION:		FY 2023-24 STANDARD PLANS	CURB INLET TYPE 9	INDEX	SHEET
					425-024	2 of 3

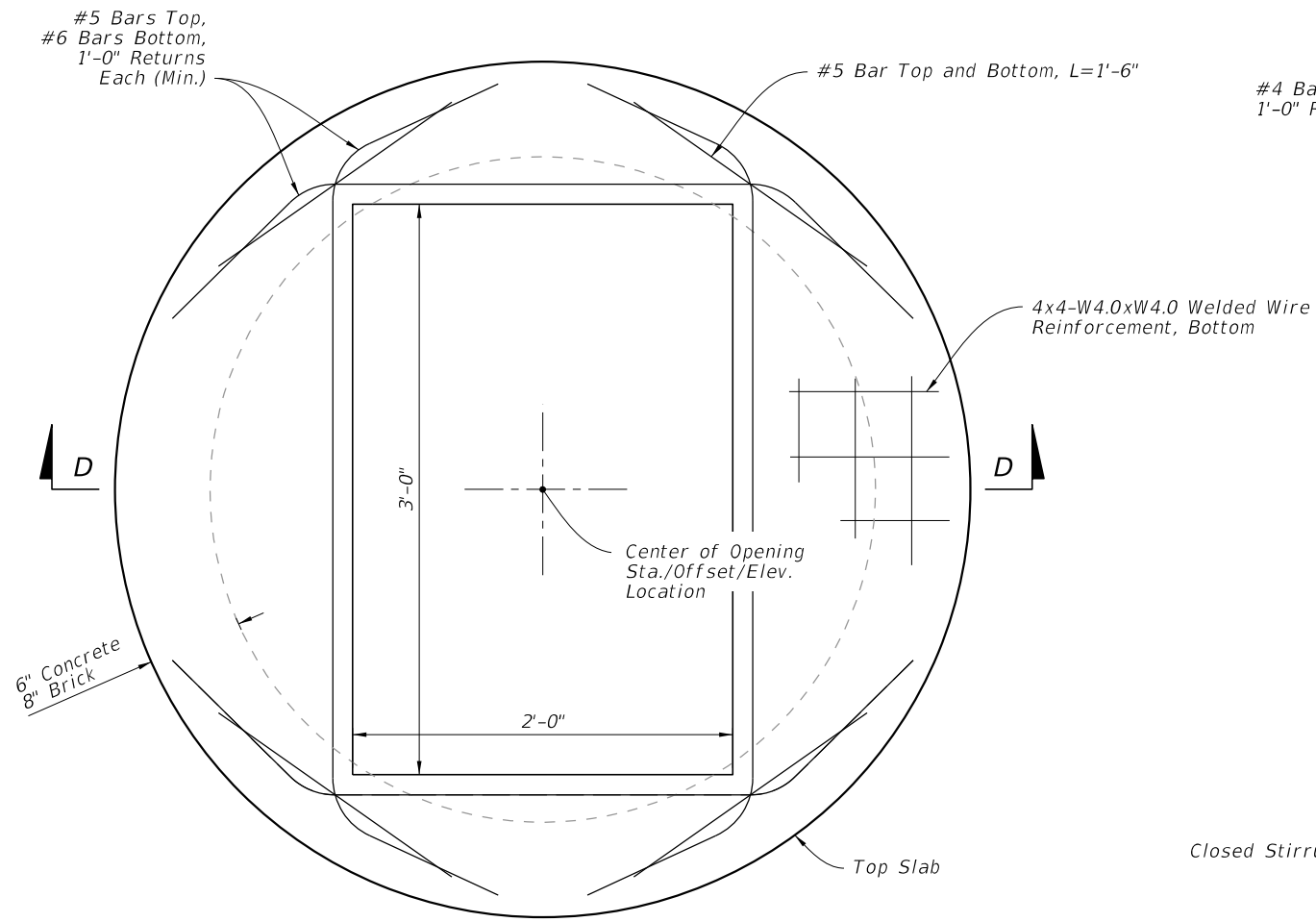

PLAN

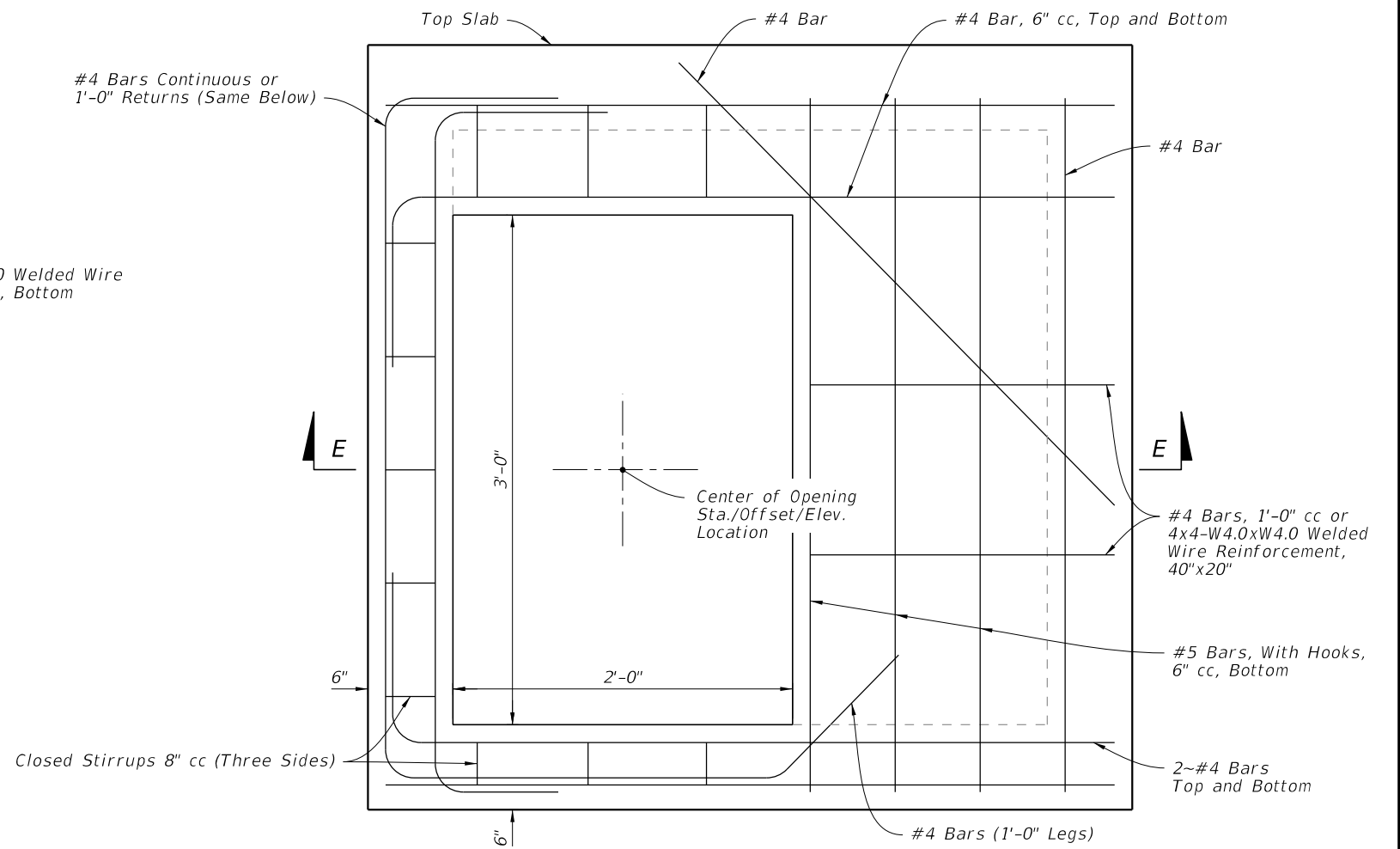

PLAN

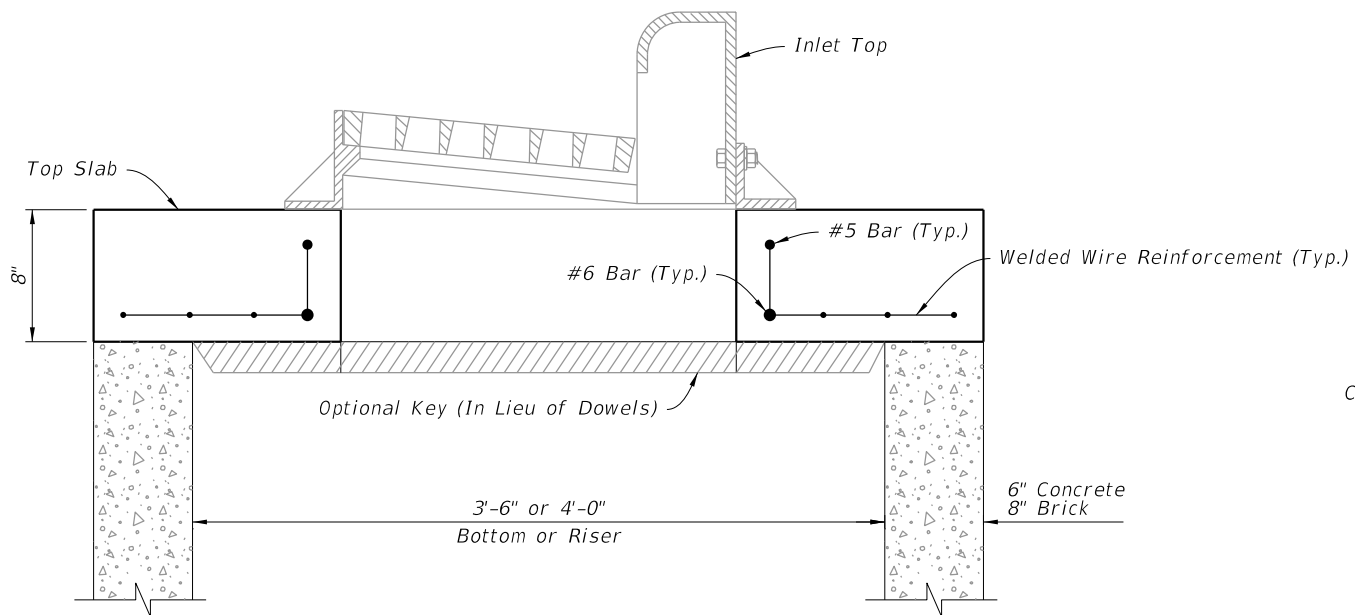

SECTION D-D

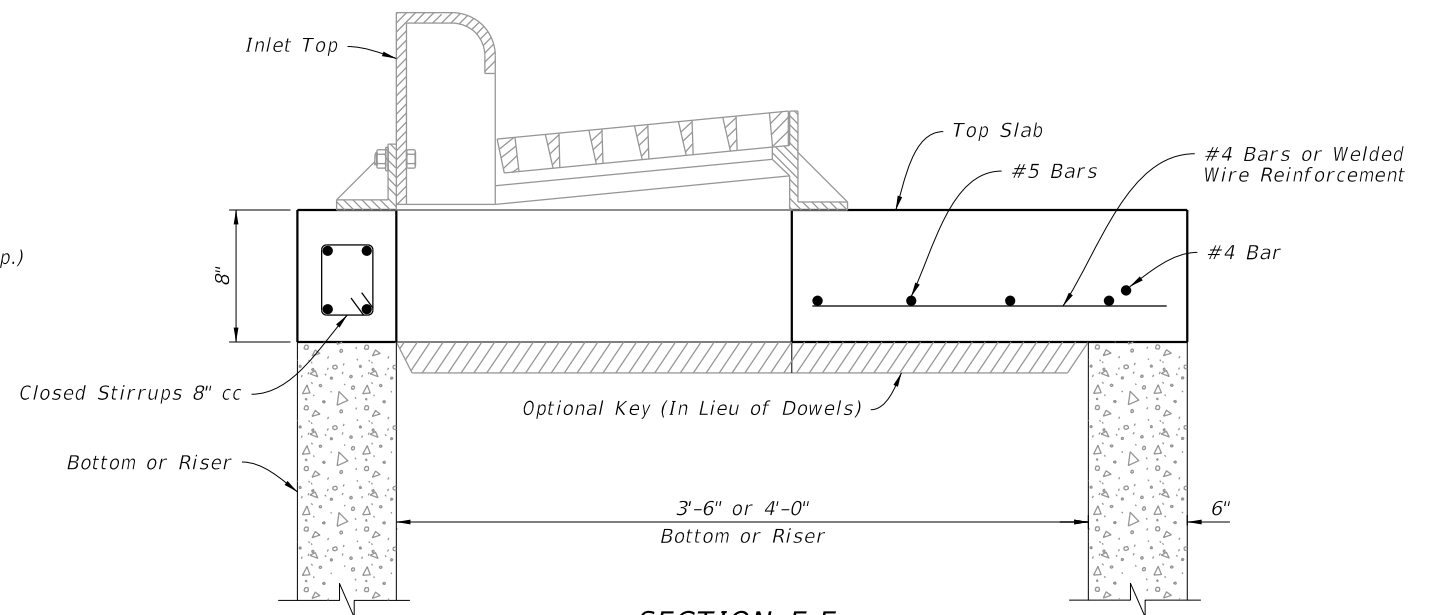

SECTION E-E

TOP SLAB DETAILS

10/19/2022 7:59:05 AM

LAST REVISION 10/01/20	REVISION	DESCRIPTION:
---------------------------	----------	--------------