

10/6/2022 10:51:14 AM

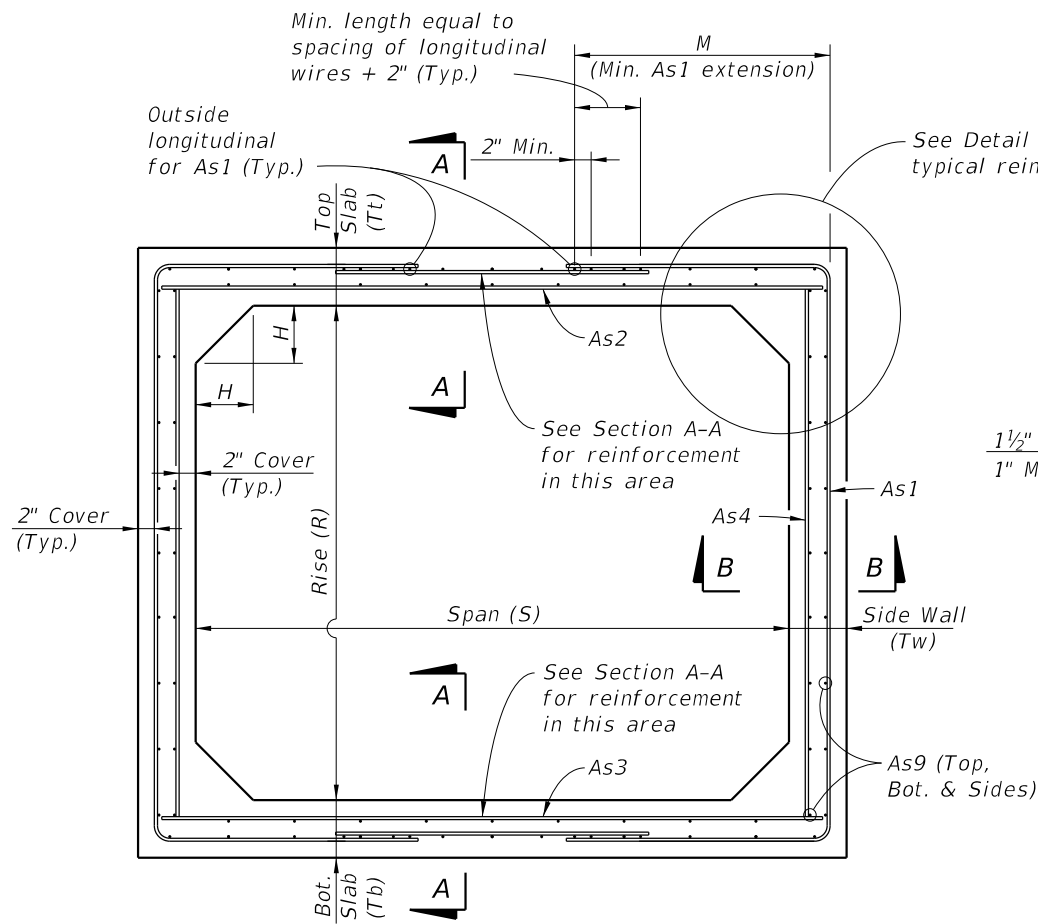

**TYPICAL BOX SECTION (TYPE 2)
DESIGN EARTH COVER 2' OR GREATER
(Option 1 Reinforcing Configuration Shown)**

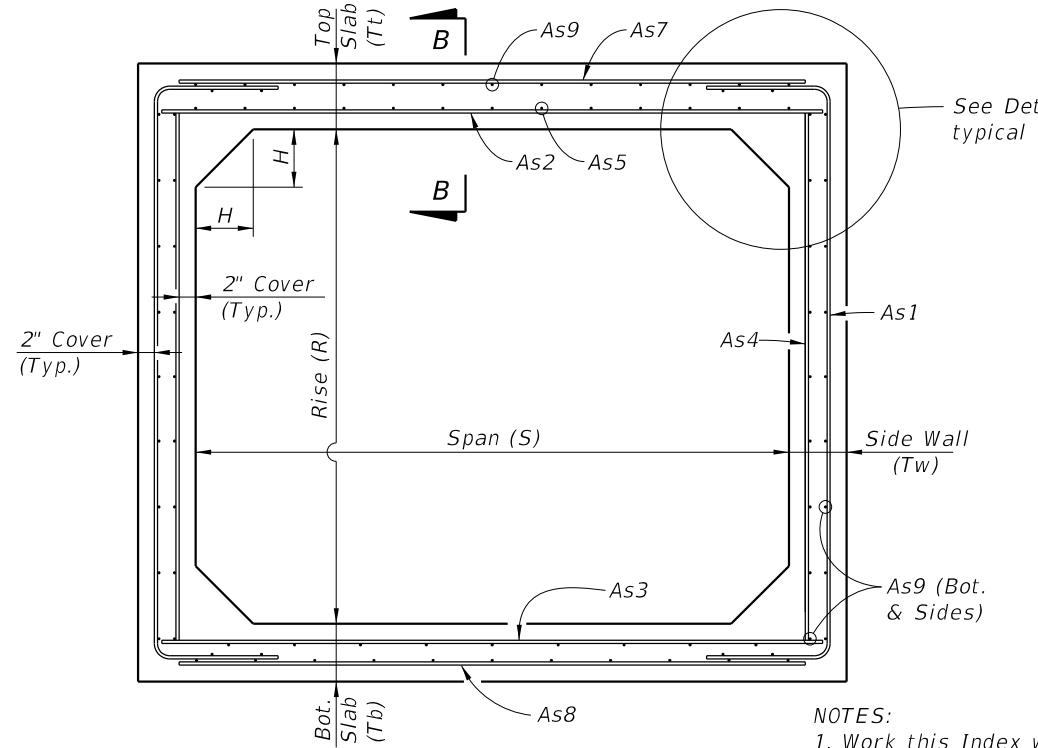

**TYPICAL BOX SECTION (TYPE 1)
DESIGN EARTH COVER LESS THAN 2'
(Option 1 Reinforcing Configuration Shown)**

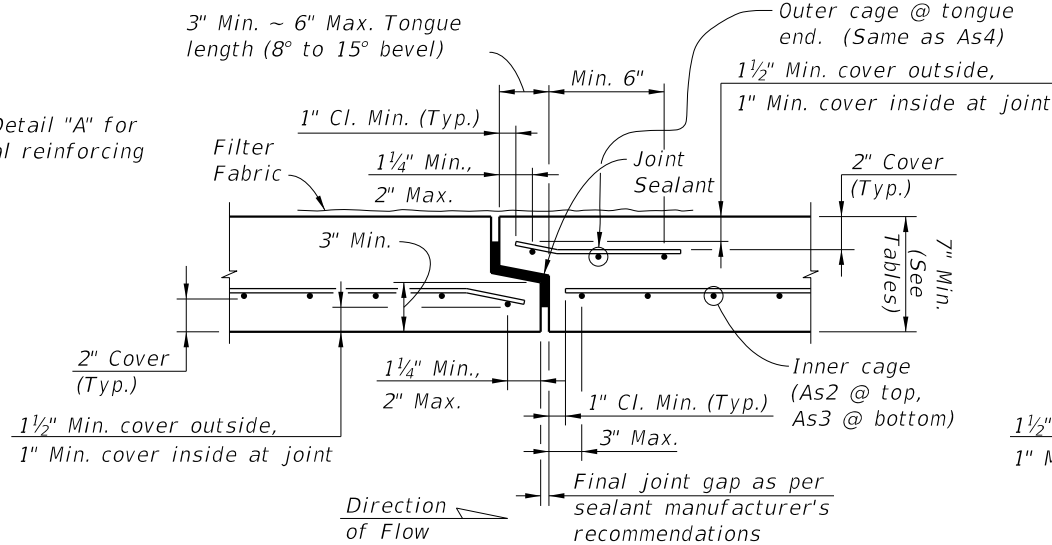

SECTION A-A

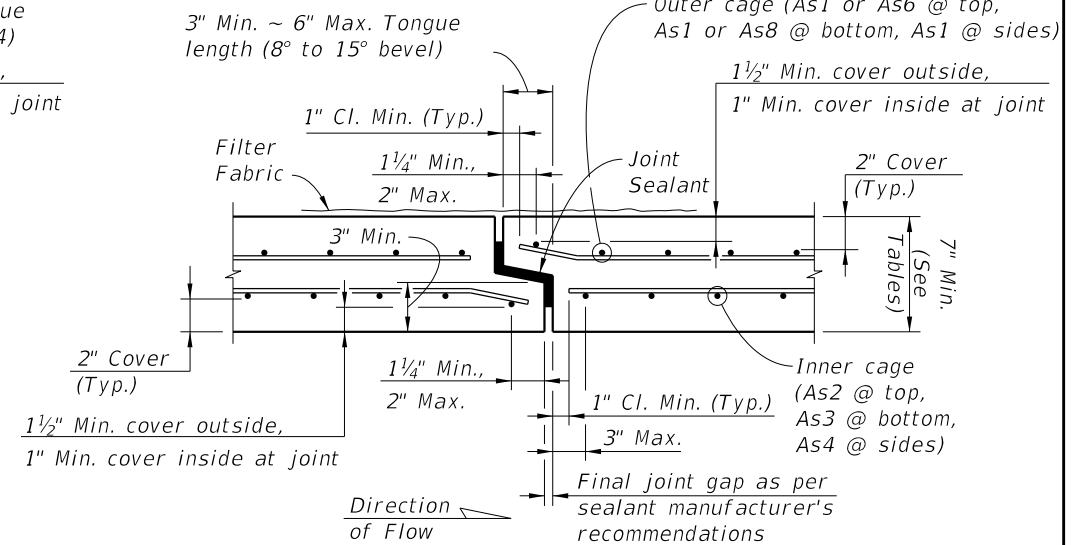

**SECTION B-B
TYPICAL SECTION THRU JOINT**

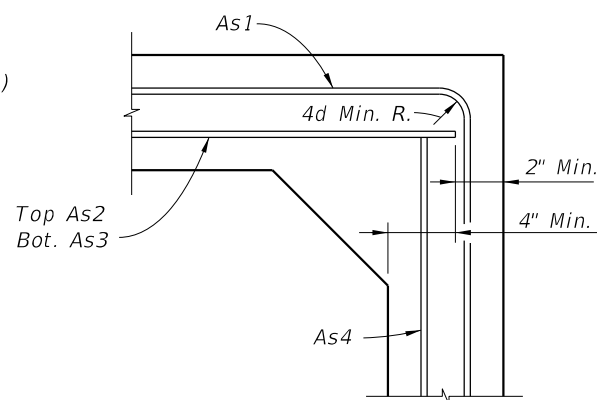

**DETAIL "A"
(OPTION 1)**

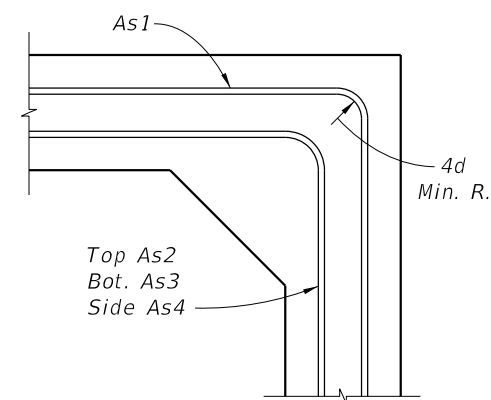

**DETAIL "A"
(OPTION 2)**

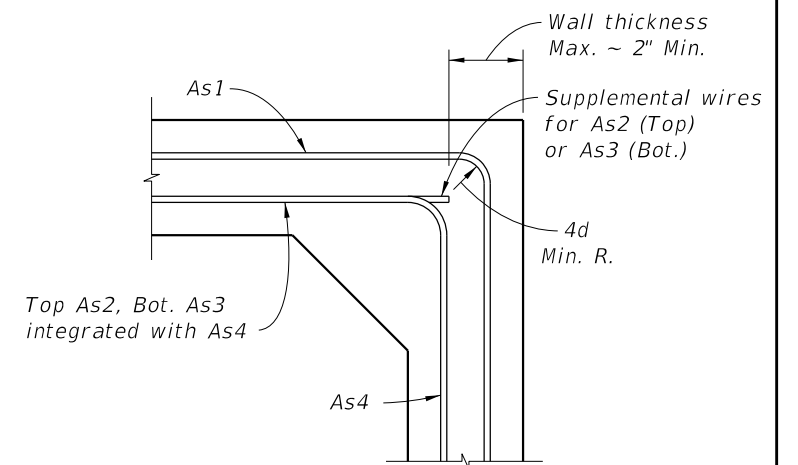

**DETAIL "A"
(OPTION 3)**

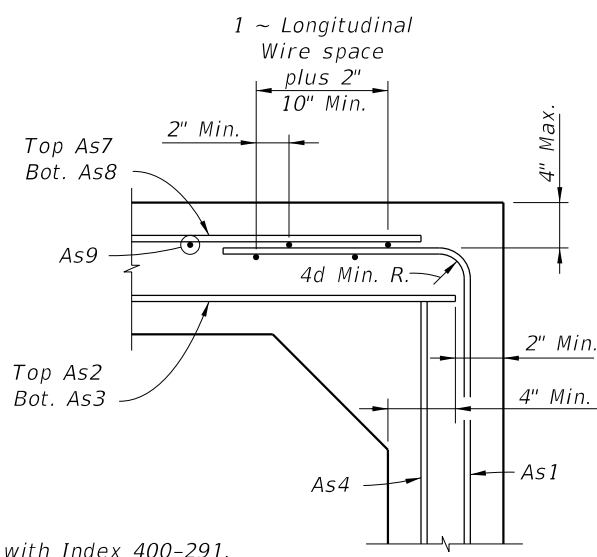

**DETAIL "B"
(OPTION 1)**

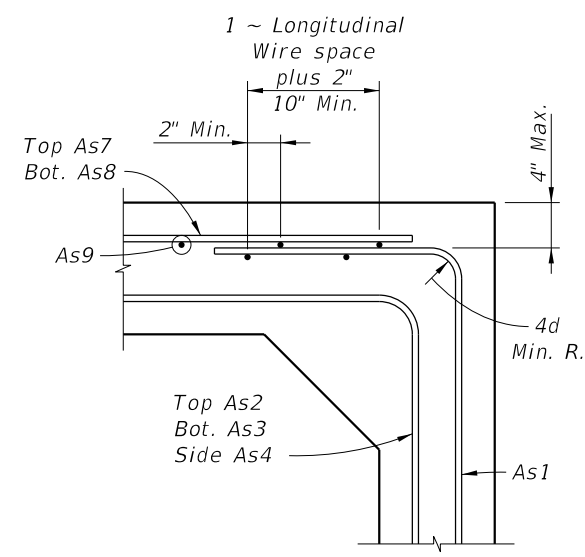

**DETAIL "B"
(OPTION 2)**

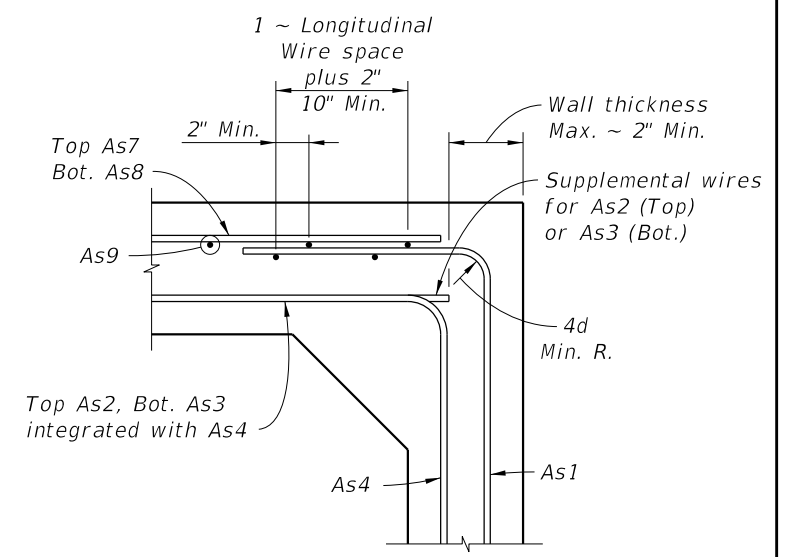

**DETAIL "B"
(OPTION 3)**

- NOTES:**
1. Work this Index with Index 400-291.
2. See sheets 2 thru 5 for dimensions and areas of reinforcement.

STANDARD PRECAST BOX CULVERT WITH 2" CONCRETE COVER

| | |
|---------------------------|--------------|
| LAST REVISION 07/01/13 | DESCRIPTION: |
|---------------------------|--------------|

GENERAL NOTES:

1. These precast designs may be substituted for cast-in-place box culverts designed to AASHTO LRFD Bridge Design Specifications, 4th Edition. Designs are based on the design criteria shown in FDOT Structures Design Guidelines.
2. Loading: HL-93 & any fill heights between the minimum & maximum shown.
3. Only one design of precast box culvert is to be used for any installation.
4. Reinforcing steel must consist of smooth or deformed welded wire reinforcement (WWR) meeting the requirements of Specification Section 931. Longitudinal reinforcement may consist of reinforcing bars meeting the requirements of Specification Section 931. Minimum cover must be 2" for slightly or moderately aggressive environments or 3" for extremely aggressive environments, unless otherwise shown. The spacing of circumferential wires must not be less than 2" nor more than 4". The spacing of longitudinal wires or bars must not be more than 8".
5. As9 longitudinal wires must have a minimum cross-sectional area of 40% of the circumferential wires, but not less than a W2.5 or D4.0 for WWR, or #3 bars for deformed bars.
6. Welding of reinforcement must be limited to the locations shown in ASTM C1577 and in accordance with ANSI/AWS D1.4 "Structural Welding Code - Reinforcing Steel".
7. For alternate reinforcing configuration Options 2 and 3 shown in Detail "A" and "B" (Sheet 1), As1 may be extended to the middle of either slab and lap spliced with As7 and As8. As4 may be lap spliced at any location or connected to As2 or As3 at corners by welding.
8. Haunch dimensions may vary between the minimum and maximum dimensions shown in the Design Tables but only one haunch dimension must be used within the full length of the box culvert installation.

9. Submittal of redesign calculations are not required for any increase to the slab and/or wall thickness when the minimum reinforcement areas shown in the Design Tables are provided.
10. For Design Earth Cover greater than 10 feet, the Contractor may interpolate the required areas of reinforcement and slab or wall thickness. Interpolated areas of reinforcement, slab or wall thickness must be approved by the Engineer.
11. Minimum length of precast box segments is 4 feet and maximum length is 16 feet.
12. See Index 400-291 for connections to wingwalls, headwalls and other general details.

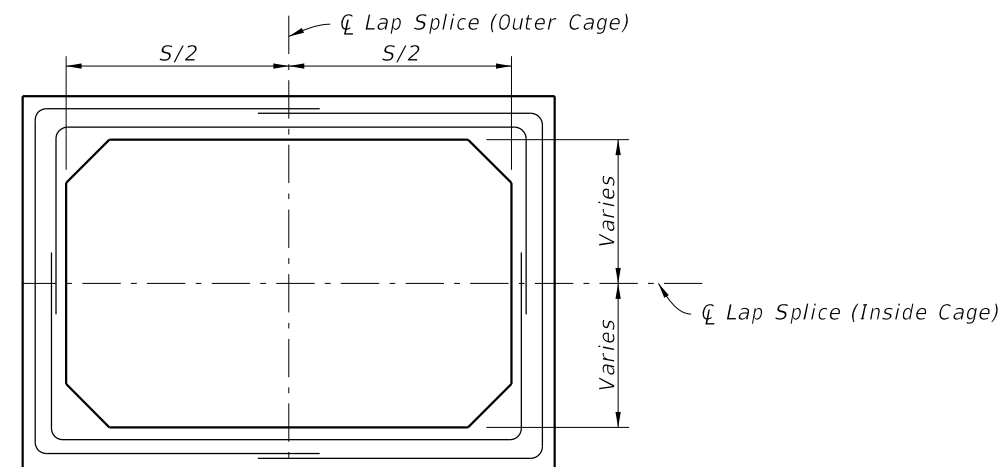

SCHEMATIC OF LAP SPLICE LOCATIONS FOR OPTION 2 & 3 REINFORCING CONFIGURATIONS

TABLE 1A - STANDARD PRECAST BOX CULVERT DESIGNS (2" COVER) - 3' & 4' SPANS

| SPAN x RISE (S) (R) (Ft.) | SLAB / WALL THICKNESS | | | | DESIGN EARTH COVER ABOVE TOP SLAB | REINFORCEMENT AREAS (sq. in./Ft.) | | | | | | | | As1 EXT. LENGTH (M) (in.) | | | | | |
|---------------------------------|-----------------------|-----------------------|-----------------------|------------------------|--|--------------------------------------|------|------|------|-------------|------|------|--------------------|------------------------------------|------|------|------|------|---|
| | TOP (Tt) (in.) | BOT. (Tb) (in.) | SIDE (Tw) (in.) | HAUNCH (H) (in.) | | As1 | As2 | As3 | As4 | As5 | As7 | As8 | As9 | | | | | | |
| 3' x 3' | 7 | 7 | 7 | 4 | 0.33' - <2' | 0.17 | 0.29 | 0.21 | 0.17 | 0.17 | 0.17 | 0.17 | See General Note 5 | - | | | | | |
| | | | | | 2' - <3' | 0.13 | 0.28 | 0.21 | 0.09 | - | - | - | | 31 | | | | | |
| | | | | | 3' - <5' | 0.09 | 0.17 | 0.17 | 0.09 | - | - | - | | 31 | | | | | |
| | | | | | 5' - 10' | 0.09 | 0.17 | 0.17 | 0.09 | - | - | - | | 31 | | | | | |
| | | | | | 15' | 0.09 | 0.17 | 0.17 | 0.09 | - | - | - | | 31 | | | | | |
| | | | | | 20' | 0.12 | 0.17 | 0.17 | 0.09 | - | - | - | | 31 | | | | | |
| | | | | | 25' | 0.14 | 0.18 | 0.18 | 0.09 | - | - | - | | 31 | | | | | |
| | | | | | 30' | 0.17 | 0.21 | 0.22 | 0.09 | - | - | - | | 31 | | | | | |
| | | | | | 35' | 0.19 | 0.25 | 0.25 | 0.09 | - | - | - | | 31 | | | | | |
| | | | | | 8 | 8 | 8 | 8 | 8 | 0.33' - <2' | 0.19 | 0.38 | | 0.26 | 0.17 | 0.19 | 0.17 | 0.19 | - |
| 2' - <3' | 0.19 | 0.38 | 0.26 | 0.09 | - | - | - | 38 | | | | | | | | | | | |
| 3' - <5' | 0.14 | 0.20 | 0.22 | 0.09 | - | - | - | 38 | | | | | | | | | | | |
| 5' - 10' | 0.11 | 0.17 | 0.17 | 0.09 | - | - | - | 38 | | | | | | | | | | | |
| 15' | 0.15 | 0.17 | 0.18 | 0.09 | - | - | - | 38 | | | | | | | | | | | |
| 20' | 0.20 | 0.23 | 0.23 | 0.09 | - | - | - | 38 | | | | | | | | | | | |
| 25' | 0.24 | 0.28 | 0.29 | 0.09 | - | - | - | 38 | | | | | | | | | | | |
| 30' | 0.29 | 0.34 | 0.35 | 0.09 | - | - | - | 38 | | | | | | | | | | | |
| 4' x 3' | 7 | 7 | 7 | 4 | 0.33' - <2' | 0.19 | 0.41 | 0.28 | 0.17 | 0.21 | 0.17 | 0.19 | See General Note 5 | - | | | | | |
| | | | | | 2' - <3' | 0.19 | 0.41 | 0.28 | 0.09 | - | - | - | | 38 | | | | | |
| | | | | | 3' - <5' | 0.14 | 0.21 | 0.24 | 0.09 | - | - | - | | 38 | | | | | |
| | | | | | 5' - 10' | 0.12 | 0.17 | 0.17 | 0.09 | - | - | - | | 38 | | | | | |
| | | | | | 15' | 0.16 | 0.19 | 0.20 | 0.09 | - | - | - | | 38 | | | | | |
| | | | | | 20' | 0.21 | 0.25 | 0.25 | 0.09 | - | - | - | | 38 | | | | | |
| | | | | | 25' | 0.26 | 0.31 | 0.32 | 0.09 | - | - | - | | 38 | | | | | |
| | | | | | 30' | 0.31 | 0.37 | 0.38 | 0.09 | - | - | - | | 38 | | | | | |
| | | | | | 4 | 4 | 4 | 4 | 4 | 0.33' - <2' | 0.19 | 0.41 | | 0.28 | 0.17 | 0.21 | 0.17 | 0.19 | - |
| | | | | | 2' - <3' | 0.19 | 0.41 | 0.28 | 0.09 | - | - | - | | 38 | | | | | |
| 3' - <5' | 0.14 | 0.21 | 0.24 | 0.09 | - | - | - | 38 | | | | | | | | | | | |
| 5' - 10' | 0.12 | 0.17 | 0.17 | 0.09 | - | - | - | 38 | | | | | | | | | | | |
| 15' | 0.16 | 0.19 | 0.20 | 0.09 | - | - | - | 38 | | | | | | | | | | | |
| 20' | 0.21 | 0.25 | 0.25 | 0.09 | - | - | - | 38 | | | | | | | | | | | |
| 25' | 0.26 | 0.31 | 0.32 | 0.09 | - | - | - | 38 | | | | | | | | | | | |
| 30' | 0.31 | 0.37 | 0.38 | 0.09 | - | - | - | 38 | | | | | | | | | | | |

TABLE 1B - STANDARD PRECAST BOX CULVERT DESIGNS (2" COVER) - 3' & 4' SPANS

| SPAN x RISE (S) (R) (Ft.) | SLAB / WALL THICKNESS | | | | DESIGN EARTH COVER ABOVE TOP SLAB | REINFORCEMENT AREAS (sq. in./Ft.) | | | | | | | | As1 EXT. LENGTH (M) (in.) | | | | | |
|---------------------------------|-----------------------|-----------------------|-----------------------|------------------------|--|--------------------------------------|------|------|------|-------------|------|------|--------------------|------------------------------------|------|------|------|------|---|
| | TOP (Tt) (in.) | BOT. (Tb) (in.) | SIDE (Tw) (in.) | HAUNCH (H) (in.) | | As1 | As2 | As3 | As4 | As5 | As7 | As8 | As9 | | | | | | |
| 3' x 3' | 8 | 8 | 8 | 4 | 0.33' - <2' | 0.20 | 0.26 | 0.32 | 0.20 | 0.20 | 0.20 | 0.20 | See General Note 5 | - | | | | | |
| | | | | | 2' - <3' | 0.16 | 0.25 | 0.31 | 0.10 | - | - | - | | 31 | | | | | |
| | | | | | 3' - <5' | 0.10 | 0.20 | 0.20 | 0.10 | - | - | - | | 31 | | | | | |
| | | | | | 5' - 10' | 0.10 | 0.20 | 0.20 | 0.10 | - | - | - | | 31 | | | | | |
| | | | | | 15' | 0.10 | 0.20 | 0.20 | 0.10 | - | - | - | | 31 | | | | | |
| | | | | | 20' | 0.10 | 0.20 | 0.20 | 0.10 | - | - | - | | 31 | | | | | |
| | | | | | 25' | 0.11 | 0.20 | 0.20 | 0.10 | - | - | - | | 31 | | | | | |
| | | | | | 30' | 0.13 | 0.20 | 0.20 | 0.10 | - | - | - | | 31 | | | | | |
| | | | | | 35' | 0.15 | 0.21 | 0.21 | 0.10 | - | - | - | | 31 | | | | | |
| | | | | | 4 | 4 | 4 | 4 | 4 | 0.33' - <2' | 0.20 | 0.31 | | 0.22 | 0.20 | 0.20 | 0.20 | 0.20 | - |
| 2' - <3' | 0.12 | 0.31 | 0.22 | 0.10 | - | - | - | 38 | | | | | | | | | | | |
| 3' - <5' | 0.12 | 0.20 | 0.20 | 0.10 | - | - | - | 38 | | | | | | | | | | | |
| 5' - 10' | 0.10 | 0.20 | 0.20 | 0.10 | - | - | - | 38 | | | | | | | | | | | |
| 15' | 0.12 | 0.20 | 0.20 | 0.10 | - | - | - | 38 | | | | | | | | | | | |
| 20' | 0.16 | 0.20 | 0.20 | 0.10 | - | - | - | 38 | | | | | | | | | | | |
| 25' | 0.19 | 0.24 | 0.24 | 0.10 | - | - | - | 38 | | | | | | | | | | | |
| 30' | 0.22 | 0.28 | 0.29 | 0.10 | - | - | - | 38 | | | | | | | | | | | |
| 4' x 4' | 8 | 8 | 8 | 4 | 0.33' - <2' | 0.20 | 0.33 | 0.24 | 0.20 | 0.20 | 0.20 | 0.20 | See General Note 5 | - | | | | | |
| | | | | | 2' - <3' | 0.17 | 0.33 | 0.24 | 0.10 | - | - | - | | 38 | | | | | |
| | | | | | 3' - <5' | 0.12 | 0.20 | 0.20 | 0.10 | - | - | - | | 38 | | | | | |
| | | | | | 5' - 10' | 0.10 | 0.20 | 0.20 | 0.10 | - | - | - | | 38 | | | | | |
| | | | | | 15' | 0.13 | 0.20 | 0.20 | 0.10 | - | - | - | | 38 | | | | | |
| | | | | | 20' | 0.16 | 0.21 | 0.22 | 0.10 | - | - | - | | 38 | | | | | |
| | | | | | 25' | 0.20 | 0.26 | 0.27 | 0.10 | - | - | - | | 38 | | | | | |
| | | | | | 30' | 0.23 | 0.31 | 0.32 | 0.10 | - | - | - | | 38 | | | | | |
| | | | | | 4 | 4 | 4 | 4 | 4 | 0.33' - <2' | 0.20 | 0.33 | | 0.24 | 0.20 | 0.20 | 0.20 | 0.20 | - |
| | | | | | 2' - <3' | 0.17 | 0.33 | 0.24 | 0.10 | - | - | - | | 38 | | | | | |
| 3' - <5' | 0.12 | 0.20 | 0.20 | 0.10 | - | - | - | 38 | | | | | | | | | | | |
| 5' - 10' | 0.10 | 0.20 | 0.20 | 0.10 | - | - | - | 38 | | | | | | | | | | | |
| 15' | 0.13 | 0.20 | 0.20 | 0.10 | - | - | - | 38 | | | | | | | | | | | |
| 20' | 0.16 | 0.21 | 0.22 | 0.10 | - | - | - | 38 | | | | | | | | | | | |
| 25' | 0.20 | 0.26 | 0.27 | 0.10 | - | - | - | 38 | | | | | | | | | | | |
| 30' | 0.23 | 0.31 | 0.32 | 0.10 | - | - | - | 38 | | | | | | | | | | | |

NOTES: 1. See Sheet 1 for Reinforcing Details and dimension locations.
2. See Sheet 14 for WWR Bending Diagram.

8/14/2023 3:02:59 PM

10/6/2022 10:51:16 AM

TABLE 2A - STANDARD PRECAST BOX CULVERT DESIGNS (2" COVER) - 5' & 6' SPANS

| SPAN x RISE (S) (R) (Ft.) | SLAB / WALL THICKNESS | | | | DESIGN EARTH COVER ABOVE TOP SLAB | REINFORCEMENT AREAS (sq. in./Ft.) | | | | | | | | | As1 EXT. LENGTH (M) (in.) | | | |
|------------------------------------|-----------------------|-----------------------|-----------------------|------------------------|--|--------------------------------------|------|------|------|-------------|------|-------|------|------|------------------------------------|------|------|----|
| | TOP (Tt) (in.) | BOT. (Tb) (in.) | SIDE (Tw) (in.) | HAUNCH (H) (in.) | | As1 | As2 | As3 | As4 | As5 | As7 | As8 | As9 | | | | | |
| | | | | | | | | | | | | | | | | | | |
| 5' x 3' | 7 | 7 | 7 | 4 | 0.33' - <2' | 0.31 | 0.48 | 0.42 | 0.17 | 0.21 | 0.23 | 0.31 | - | | | | | |
| | | | | | 2' - <3' | 0.31 | 0.48 | 0.42 | 0.09 | - | - | - | 45 | | | | | |
| | | | | | 3' - <5' | 0.20 | 0.27 | 0.27 | 0.09 | - | - | - | 36 | | | | | |
| | | | | 8 | 5' - 10' | 0.17 | 0.19 | 0.21 | 0.09 | - | - | - | 36 | | | | | |
| | | | | | 15' | 0.24 | 0.25 | 0.25 | 0.09 | - | - | - | 35 | | | | | |
| | | | | | 20' | 0.32 | 0.33 | 0.33 | 0.09 | - | - | - | 35 | | | | | |
| | 7 | 7 | 7 | 8 | 25' | 0.39 | 0.41 | 0.42 | 0.09 | - | - | - | 35 | | | | | |
| | | | | | 30' | 0.47 | 0.50 | 0.50 | 0.09 | - | - | - | 35 | | | | | |
| | | | | | 5' x 4' | 7 | 7 | 7 | 4 | 0.33' - <2' | 0.30 | 0.51 | 0.45 | 0.17 | 0.23 | 0.21 | 0.30 | - |
| | | | | | | | | | | 2' - <3' | 0.30 | 0.51 | 0.45 | 0.09 | - | - | - | 45 |
| | | | | | | | | | | 3' - <5' | 0.18 | 0.30 | 0.29 | 0.09 | - | - | - | 45 |
| | | | | | | | | | 8 | 5' - 10' | 0.17 | 0.21 | 0.23 | 0.09 | - | - | - | 36 |
| 15' | 0.24 | 0.27 | 0.28 | 0.09 | | | | | | - | - | - | 35 | | | | | |
| 20' | 0.31 | 0.36 | 0.37 | 0.09 | | | | | | - | - | - | 35 | | | | | |
| 7 | 7 | 7 | 8 | 25' | | 0.39 | 0.45 | 0.46 | 0.09 | - | - | - | 35 | | | | | |
| | | | | 30' | | 0.46 | 0.55 | 0.56 | 0.09 | - | - | - | 35 | | | | | |
| | | | | 5' x 5' | | 7 | 7 | 7 | 4 | 0.33' - <2' | 0.30 | 0.53 | 0.48 | 0.17 | 0.24 | 0.21 | 0.30 | - |
| | | | | | | | | | | 2' - <3' | 0.29 | 0.53 | 0.48 | 0.09 | - | - | - | 45 |
| | | | | | | | | | | 3' - <5' | 0.19 | 0.31 | 0.31 | 0.09 | - | - | - | 45 |
| | | | | | | | | | 8 | 5' - 10' | 0.19 | 0.22 | 0.25 | 0.09 | - | - | - | 45 |
| 15' | 0.26 | 0.29 | 0.31 | | 0.09 | | | | | - | - | - | 36 | | | | | |
| 20' | 0.34 | 0.39 | 0.40 | | 0.09 | | | | | - | - | - | 35 | | | | | |
| 7 | 7 | 7 | 8 | | 25' | 0.41 | 0.49 | 0.50 | 0.09 | - | - | - | 35 | | | | | |
| | | | | | 30' | 0.49 | 0.59 | 0.61 | 0.09 | - | - | - | 35 | | | | | |
| | | | | | 6' x 3' | 7.5 | 7 | 7 | 4 | 0.33' - <2' | 0.39 | 0.54 | 0.48 | 0.17 | 0.22 | 0.25 | 0.39 | - |
| | | | | | | | | | | 2' - <3' | 0.39 | 0.58 | 0.49 | 0.09 | - | - | - | 43 |
| | | | | | | | | | | 3' - <5' | 0.28 | 0.36 | 0.36 | 0.09 | - | - | - | 39 |
| | | | | | | | | | 12 | 5' - 10' | 0.25 | 0.26 | 0.28 | 0.09 | - | - | - | 39 |
| 15' | 0.36 | 0.34 | 0.34 | 0.09 | | | | | | - | - | - | 38 | | | | | |
| 20' | 0.47 | 0.46 | 0.46 | 0.09 | | | | | | - | - | - | 38 | | | | | |
| 7 | 7.5 | 7 | 12 | 25' | | 0.59 | 0.57 | 0.55 | 0.09 | - | - | - | 38 | | | | | |
| | | | | 30' | | 0.60 | 0.64 | 0.64 | 0.09 | - | - | - | 38 | | | | | |
| | | | | 6' x 4' | | 7.5 | 7 | 7 | 4 | 0.33' - <2' | 0.37 | 0.58 | 0.52 | 0.17 | 0.24 | 0.23 | 0.37 | - |
| | | | | | | | | | | 2' - <3' | 0.37 | 0.61 | 0.53 | 0.09 | - | - | - | 43 |
| | | | | | | | | | | 3' - <5' | 0.26 | 0.39 | 0.39 | 0.09 | - | - | - | 39 |
| | | | | | | | | | 12 | 5' - 10' | 0.24 | 0.28 | 0.31 | 0.09 | - | - | - | 39 |
| 15' | 0.35 | 0.37 | 0.38 | | 0.09 | | | | | - | - | - | 38 | | | | | |
| 20' | 0.46 | 0.50 | 0.50 | | 0.09 | | | | | - | - | - | 38 | | | | | |
| 7 | 7.5 | 7 | 12 | | 25' | 0.56 | 0.63 | 0.60 | 0.09 | - | - | - | 38 | | | | | |
| | | | | | 30' | 0.58 | 0.69 | 0.69 | 0.09 | - | - | - | 38 | | | | | |
| | | | | | 6' x 5' | 7.5 | 7 | 7 | 4 | 0.33' - <2' | 0.36 | 0.60 | 0.56 | 0.17 | 0.25 | 0.22 | 0.36 | - |
| | | | | | | | | | | 2' - <3' | 0.36 | 0.64 | 0.56 | 0.09 | - | - | - | 43 |
| | | | | | | | | | | 3' - <5' | 0.26 | 0.410 | 0.42 | 0.09 | - | - | - | 43 |
| | | | | | | | | | 12 | 5' - 10' | 0.25 | 0.30 | 0.33 | 0.09 | - | - | - | 39 |
| 15' | 0.34 | 0.40 | 0.41 | 0.09 | | | | | | - | - | - | 38 | | | | | |
| 20' | 0.46 | 0.54 | 0.54 | 0.09 | | | | | | - | - | - | 38 | | | | | |
| 7 | 7.5 | 8 | 12 | 25' | | 0.56 | 0.67 | 0.65 | 0.09 | - | - | - | 38 | | | | | |
| | | | | 30' | | 0.60 | 0.74 | 0.74 | 0.09 | - | - | - | 38 | | | | | |
| | | | | 6' x 6' | | 7.5 | 7 | 7 | 4 | 0.33' - <2' | 0.36 | 0.63 | 0.59 | 0.17 | 0.26 | 0.22 | 0.36 | - |
| | | | | | | | | | | 2' - <3' | 0.35 | 0.67 | 0.59 | 0.09 | - | - | - | 52 |
| | | | | | | | | | | 3' - <5' | 0.27 | 0.43 | 0.44 | 0.09 | - | - | - | 52 |
| | | | | | | | | | 12 | 5' - 10' | 0.27 | 0.32 | 0.35 | 0.09 | - | - | - | 43 |
| 15' | 0.38 | 0.43 | 0.44 | | 0.09 | | | | | - | - | - | 39 | | | | | |
| 20' | 0.50 | 0.57 | 0.59 | | 0.09 | | | | | - | - | - | 39 | | | | | |
| 7 | 7.5 | 7 | 12 | | 25' | 0.60 | 0.72 | 0.70 | 0.09 | - | - | - | 38 | | | | | |
| | | | | | 30' | 0.67 | 0.78 | 0.79 | 0.09 | - | - | - | 38 | | | | | |

See General Note 5

TABLE 2B - STANDARD PRECAST BOX CULVERT DESIGNS (2" COVER) - 5' & 6' SPANS

| SPAN x RISE (S) (R) (Ft.) | SLAB / WALL THICKNESS | | | | DESIGN EARTH COVER ABOVE TOP SLAB | REINFORCEMENT AREAS (sq. in./Ft.) | | | | | | | | | As1 EXT. LENGTH (M) (in.) | | | |
|------------------------------------|-----------------------|-----------------------|-----------------------|------------------------|--|--------------------------------------|------|------|------|-------------|------|------|------|------|------------------------------------|------|------|----|
| | TOP (Tt) (in.) | BOT. (Tb) (in.) | SIDE (Tw) (in.) | HAUNCH (H) (in.) | | As1 | As2 | As3 | As4 | As5 | As7 | As8 | As9 | | | | | |
| | | | | | | | | | | | | | | | | | | |
| 5' x 3' | 8 | 8 | 8 | 4 | 0.33' - <2' | 0.26 | 0.39 | 0.36 | 0.20 | 0.20 | 0.20 | 0.26 | - | | | | | |
| | | | | | 2' - <3' | 0.26 | 0.39 | 0.36 | 0.10 | - | - | - | 45 | | | | | |
| | | | | | 3' - <5' | 0.16 | 0.23 | 0.24 | 0.10 | - | - | - | 36 | | | | | |
| | | | | 8 | 5' - 10' | 0.13 | 0.20 | 0.20 | 0.10 | - | - | - | 36 | | | | | |
| | | | | | 15' | 0.19 | 0.21 | 0.22 | 0.10 | - | - | - | 35 | | | | | |
| | | | | | 20' | 0.24 | 0.28 | 0.28 | 0.10 | - | - | - | 35 | | | | | |
| | 8 | 8 | 8 | 8 | 25' | 0.30 | 0.34 | 0.35 | 0.10 | - | - | - | 35 | | | | | |
| | | | | | 30' | 0.36 | 0.41 | 0.41 | 0.10 | - | - | - | 35 | | | | | |
| | | | | | 5' x 4' | 8 | 8 | 8 | 4 | 0.33' - <2' | 0.25 | 0.42 | 0.38 | 0.20 | 0.20 | 0.20 | 0.25 | - |
| | | | | | | | | | | 2' - <3' | 0.25 | 0.42 | 0.38 | 0.10 | - | - | - | 45 |
| | | | | | | | | | | 3' - <5' | 0.16 | 0.25 | 0.25 | 0.10 | - | - | - | 45 |
| | | | | | | | | | 8 | 5' - 10' | 0.13 | 0.20 | 0.20 | 0.10 | - | - | - | 36 |
| 15' | 0.19 | 0.23 | 0.24 | 0.10 | | | | | | - | - | - | 35 | | | | | |
| 20' | 0.24 | 0.30 | 0.31 | 0.10 | | | | | | - | - | - | 35 | | | | | |
| 8 | 8 | 8 | 8 | 25' | | 0.30 | 0.37 | 0.38 | 0.10 | - | - | - | 35 | | | | | |
| | | | | 30' | | 0.35 | 0.45 | 0.46 | 0.10 | - | - | - | 35 | | | | | |
| | | | | 5' x 5' | | 8 | 8 | 8 | 4 | 0.33' - <2' | 0.25 | 0.44 | 0.41 | 0.20 | 0.20 | 0.20 | 0.25 | - |
| | | | | | | | | | | 2' - <3' | 0.25 | 0.44 | 0.41 | 0.10 | - | - | - | 45 |
| | | | | | | | | | | 3' - <5' | 0.16 | 0.26 | 0.27 | 0.10 | - | - | - | 45 |
| | | | | | | | | | 8 | 5' - 10' | 0.15 | 0.20 | 0.22 | 0.10 | - | - | - | 45 |
| 15' | 0.20 | 0.25 | 0.26 | | 0.10 | | | | | - | - | - | 36 | | | | | |
| 20' | 0.26 | 0.32 | 0.33 | | 0.10 | | | | | - | - | - | 35 | | | | | |
| 8 | 8 | 8 | 8 | | 25' | 0.32 | 0.40 | 0.41 | 0.10 | - | - | - | 35 | | | | | |
| | | | | | 30' | 0.37 | 0.48 | 0.49 | 0.10 | - | - | - | 35 | | | | | |
| | | | | | 6' x 3' | 8 | 8 | 8 | 4 | 0.33' - <2' | 0.32 | 0.47 | 0.41 | 0.20 | 0.20 | 0.25 | 0.32 | - |
| | | | | | | | | | | 2' - <3' | 0.32 | 0.47 | 0.41 | 0.10 | - | - | - | 43 |
| | | | | | | | | | | 3' - <5' | 0.23 | 0.30 | 0.31 | 0.10 | - | - | - | 39 |
| | | | | | | | | | 12 | 5' - 10' | 0.19 | 0.22 | 0.24 | 0.10 | - | - | - | 39 |
| 15' | 0.28 | 0.29 | 0.29 | 0.10 | | | | | | - | - | - | 38 | | | | | |
| 20' | 0.36 | 0.38 | 0.38 | 0.10 | | | | | | - | - | - | 38 | | | | | |
| 8 | 8 | 8 | 12 | 25' | | 0.45 | 0.47 | 0.47 | 0.10 | - | - | - | 38 | | | | | |
| | | | | 30' | | 0.54 | 0.57 | 0.57 | 0.10 | - | - | - | 38 | | | | | |
| | | | | 6' x 4' | | 8 | 8 | 8 | 4 | 0.33' - <2' | 0.31 | 0.50 | 0.44 | 0.20 | 0.21 | 0.23 | 0.31 | - |
| | | | | | | | | | | 2' - <3' | 0.31 | 0.50 | 0.44 | 0.10 | - | - | - | 43 |
| | | | | | | | | | | 3' - <5' | 0.23 | 0.32 | 0.34 | 0.10 | - | - | - | 39 |
| | | | | | | | | | 12 | 5' - 10' | 0.19 | 0.24 | 0.26 | 0.10 | - | - | - | 39 |
| 15' | 0.27 | 0.31 | 0.32 | | 0.10 | | | | | - | - | - | 38 | | | | | |
| 20' | 0.35 | 0.41 | 0.41 | | 0.10 | | | | | - | - | - | 38 | | | | | |
| 8 | 8 | 8 | 12 | | 25' | 0.43 | 0.51 | 0.51 | 0.10 | - | - | - | 38 | | | | | |
| | | | | | 30' | 0.52 | 0.62 | 0.62 | 0.10 | - | - | - | 38 | | | | | |
| | | | | | 6' x 5' | 8 | 8 | 8 | 4 | 0.33' - <2' | 0.30 | 0.52 | 0.47 | 0.20 | 0.22 | 0.22 | 0.30 | - |
| | | | | | | | | | | 2' - <3' | 0.30 | 0.52 | 0.47 | 0.10 | - | - | - | 43 |
| | | | | | | | | | | 3' - <5' | 0.22 | 0.34 | 0.36 | 0.10 | - | - | - | 43 |
| | | | | | | | | | 12 | 5' - 10' | 0.20 | 0.26 | 0.28 | 0.10 | - | - | - | 39 |
| 15' | 0.27 | 0.33 | 0.34 | 0.10 | | | | | | - | - | - | 38 | | | | | |
| 20' | 0.36 | 0.44 | 0.45 | 0.10 | | | | | | - | - | - | 38 | | | | | |
| 8 | 8 | 8 | 12 | 25' | | 0.44 | 0.55 | 0.55 | 0.10 | - | - | - | 38 | | | | | |
| | | | | 30' | | 0.52 | 0.66 | 0.67 | 0.10 | - | - | - | 38 | | | | | |
| | | | | 6' x 6' | | 8 | 8 | 8 | 4 | 0.33' - <2' | 0.30 | 0.54 | 0.50 | 0.20 | 0.22 | 0.22 | 0.30 | - |
| | | | | | | | | | | 2' - <3' | 0.30 | 0.54 | 0.50 | 0.10 | - | - | - | 52 |
| | | | | | | | | | | 3' - <5' | 0.23 | 0.36 | 0.38 | 0.10 | - | - | - | 52 |
| | | | | | | | | | 12 | 5' - 10' | 0.21 | 0.27 | 0.30 | 0.10 | - | - | - | 43 |
| 15' | 0.29 | 0.35 | 0.37 | | 0.10 | | | | | - | - | - | 39 | | | | | |
| 20' | 0.38 | 0.47 | 0.48 | | 0.10 | | | | | - | - | - | 39 | | | | | |
| 8 | 8 | 8 | 12 | | 25' | 0.47 | 0.59 | 0.60 | 0.10 | - | - | - | 38 | | | | | |
| | | | | | 30' | 0.55 | 0.70 | 0.71 | 0.10 | - | - | - | 38 | | | | | |

See General Note 5

10/6/2022 10:51:18 AM

TABLE 5 - STANDARD PRECAST BOX CULVERT DESIGNS (2" COVER) - 9' SPANS

| SPAN x RISE (S) (R) (Ft.) | SLAB / WALL THICKNESS | | | | DESIGN EARTH COVER ABOVE TOP SLAB | REINFORCEMENT AREAS (sq. in./Ft.) | | | | | | | | As1 EXT. LENGTH (M) (in.) | |
|--|-----------------------|-----------------------|-----------------------|------------------------|--|--------------------------------------|------|------|------|------|------|------|-----|------------------------------------|--|
| | TOP (Tt) (in.) | BOT. (Tb) (in.) | SIDE (Tw) (in.) | HAUNCH (H) (in.) | | As1 | As2 | As3 | As4 | As5 | As7 | As8 | As9 | | |
| | | | | | | | | | | | | | | | |
| 9' x 5' | 9.5 | 9.5 | 9 | 4 to 12 | 0.33' - <2' | 0.41 | 0.62 | 0.53 | 0.22 | 0.23 | 0.34 | 0.38 | - | | |
| | 9 | 9 | 9 | | 2' - <3' | 0.44 | 0.65 | 0.54 | 0.11 | - | - | - | - | 54 | |
| | | | | | 3' - <5' | 0.39 | 0.53 | 0.51 | 0.11 | - | - | - | 49 | | |
| | | | | | 5' - 10' | 0.35 | 0.42 | 0.44 | 0.11 | - | - | - | 49 | | |
| | | | | 15' | 0.50 | 0.56 | 0.55 | 0.11 | - | - | - | 44 | | | |
| | 9.5 | 9.5 | 9 | 8 to 12 | 20' | 0.65 | 0.75 | 0.73 | 0.11 | - | - | - | 44 | | |
| | 10.5 | 11 | 9 | | 25' | 0.77 | 0.92 | 0.90 | 0.11 | - | - | - | - | 44 | |
| | | | | | 30' | 0.81 | 1.05 | 1.02 | 0.11 | - | - | - | 44 | | |
| | | | | | See General Note 5 | | | | | | | | | | |
| | | | | | | | | | | | | | | | |
| 9' x 6' | 9.5 | 9.5 | 9 | 4 to 12 | 0.33' - <2' | 0.38 | 0.64 | 0.56 | 0.23 | 0.23 | 0.33 | 0.37 | - | | |
| | 9 | 9 | 9 | | 2' - <3' | 0.43 | 0.67 | 0.57 | 0.11 | - | - | - | - | 54 | |
| | | | | | 3' - <5' | 0.37 | 0.55 | 0.54 | 0.11 | - | - | - | 49 | | |
| | | | | | 5' - 10' | 0.35 | 0.45 | 0.47 | 0.11 | - | - | - | 49 | | |
| | | | | 15' | 0.49 | 0.60 | 0.59 | 0.11 | - | - | - | 44 | | | |
| | 9.5 | 9.5 | 9 | 8 to 12 | 20' | 0.65 | 0.80 | 0.78 | 0.11 | - | - | - | 44 | | |
| | 10.5 | 11 | 9 | | 25' | 0.76 | 0.98 | 0.95 | 0.11 | - | - | - | - | 44 | |
| | | | | | 30' | 0.80 | 1.10 | 1.08 | 0.11 | - | - | - | 44 | | |
| | | | | | See General Note 5 | | | | | | | | | | |
| | | | | | | | | | | | | | | | |
| 9' x 7' | 9.5 | 9.5 | 9 | 4 to 12 | 0.33' - <2' | 0.37 | 0.67 | 0.59 | 0.22 | 0.23 | 0.32 | 0.37 | - | | |
| | 9 | 9 | 9 | | 2' - <3' | 0.42 | 0.69 | 0.60 | 0.11 | - | - | - | - | 59 | |
| | | | | | 3' - <5' | 0.37 | 0.58 | 0.56 | 0.11 | - | - | - | 54 | | |
| | | | | | 5' - 10' | 0.36 | 0.47 | 0.49 | 0.11 | - | - | - | 49 | | |
| | | | | 15' | 0.50 | 0.63 | 0.63 | 0.11 | - | - | - | 44 | | | |
| | 9.5 | 9.5 | 9 | 8 to 12 | 20' | 0.66 | 0.84 | 0.80 | 0.11 | - | - | - | 44 | | |
| | 10.5 | 11 | 9 | | 25' | 0.77 | 1.02 | 1.00 | 0.11 | - | - | - | - | 44 | |
| | | | | | 30' | 0.81 | 1.15 | 1.13 | 0.11 | - | - | - | 44 | | |
| | | | | | See General Note 5 | | | | | | | | | | |
| | | | | | | | | | | | | | | | |
| 9' x 8' | 9.5 | 9.5 | 9 | 4 to 12 | 0.33' - <2' | 0.37 | 0.68 | 0.61 | 0.22 | 0.23 | 0.31 | 0.37 | - | | |
| | 9 | 9 | 9 | | 2' - <3' | 0.42 | 0.71 | 0.62 | 0.11 | - | - | - | - | 59 | |
| | | | | | 3' - <5' | 0.37 | 0.60 | 0.59 | 0.11 | - | - | - | 59 | | |
| | | | | | 5' - 10' | 0.38 | 0.49 | 0.51 | 0.11 | - | - | - | 54 | | |
| | | | | 15' | 0.53 | 0.66 | 0.66 | 0.11 | - | - | - | 44 | | | |
| | 9.5 | 9.5 | 9 | 8 to 12 | 20' | 0.68 | 0.88 | 0.87 | 0.11 | - | - | - | 44 | | |
| | 10.5 | 11 | 9 | | 25' | 0.81 | 1.07 | 1.05 | 0.11 | - | - | - | - | 44 | |
| | | | | | 30' | 0.86 | 1.20 | 1.18 | 0.11 | - | - | - | 44 | | |
| | | | | | See General Note 5 | | | | | | | | | | |
| | | | | | | | | | | | | | | | |
| 9' x 9' | 9.5 | 9.5 | 9 | 4 to 12 | 0.33' - <2' | 0.38 | 0.70 | 0.63 | 0.22 | 0.23 | 0.32 | 0.38 | - | | |
| | 9 | 9 | 9 | | 2' - <3' | 0.43 | 0.73 | 0.65 | 0.15 | - | - | - | - | 72 | |
| | | | | | 3' - <5' | 0.38 | 0.62 | 0.61 | 0.15 | - | - | - | 72 | | |
| | | | | | 5' - 10' | 0.41 | 0.50 | 0.53 | 0.14 | - | - | - | 59 | | |
| | | | | 15' | 0.57 | 0.69 | 0.70 | 0.12 | - | - | - | 49 | | | |
| | 9.5 | 9.5 | 9 | 8 to 12 | 20' | 0.73 | 0.92 | 0.91 | 0.11 | - | - | - | 49 | | |
| | 10.5 | 11 | 9 | | 25' | 0.83 | 1.11 | 1.09 | 0.11 | - | - | - | - | 44 | |
| | | | | | 30' | 0.93 | 1.25 | 1.23 | 0.11 | - | - | - | 44 | | |
| | | | | | See General Note 5 | | | | | | | | | | |
| | | | | | | | | | | | | | | | |

TABLE 6 - STANDARD PRECAST BOX CULVERT DESIGNS (2" COVER) - 10' SPANS

| SPAN x RISE (S) (R) (Ft.) | SLAB / WALL THICKNESS | | | | DESIGN EARTH COVER ABOVE TOP SLAB | REINFORCEMENT AREAS (sq. in./Ft.) | | | | | | | | As1 EXT. LENGTH (M) (in.) |
|--|-----------------------|-----------------------|-----------------------|------------------------|--|--------------------------------------|------|------|------|------|------|------|------|------------------------------------|
| | TOP (Tt) (in.) | BOT. (Tb) (in.) | SIDE (Tw) (in.) | HAUNCH (H) (in.) | | As1 | As2 | As3 | As4 | As5 | As7 | As8 | As9 | |
| | | | | | | | | | | | | | | |
| 10' x 5' | 10 | 10 | 10 | 4 to 12 | 0.33' - <2' | 0.46 | 0.62 | 0.52 | 0.24 | 0.24 | 0.41 | 0.45 | - | |
| | | | | | 2' - <3' | 0.46 | 0.62 | 0.52 | 0.12 | - | - | - | 58 | |
| | | | | | 3' - <5' | 0.42 | 0.54 | 0.50 | 0.12 | - | - | - | 53 | |
| | | | | | 5' - 10' | 0.38 | 0.46 | 0.49 | 0.12 | - | - | - | 52 | |
| | 10.5 | 10.5 | 10 | 8 to 12 | 15' | 0.52 | 0.59 | 0.58 | 0.12 | - | - | - | - | 47 |
| | | | | | 20' | 0.69 | 0.78 | 0.76 | 0.12 | - | - | - | 47 | |
| | | | | | 25' | 0.81 | 0.97 | 0.93 | 0.12 | - | - | - | 47 | |
| | | | | | 30' | 0.87 | 1.11 | 1.11 | 0.12 | - | - | - | 47 | |
| | 10' x 6' | 10 | 10 | 10 | 4 to 12 | 0.33' - <2' | 0.44 | 0.64 | 0.54 | 0.24 | 0.24 | 0.39 | 0.44 | - |
| | | | | | | 2' - <3' | 0.44 | 0.64 | 0.54 | 0.12 | - | - | - | 58 |
| 3' - <5' | | | | | | 0.39 | 0.57 | 0.52 | 0.12 | - | - | - | 52 | |
| 5' - 10' | | | | | | 0.37 | 0.48 | 0.52 | 0.12 | - | - | - | 52 | |
| 10.5 | | 10.5 | 10 | 8 to 12 | 15' | 0.51 | 0.62 | 0.61 | 0.12 | - | - | - | - | 47 |
| | | | | | 20' | 0.67 | 0.83 | 0.80 | 0.12 | - | - | - | 47 | |
| | | | | | 25' | 0.79 | 1.02 | 0.99 | 0.12 | - | - | - | 47 | |
| | | | | | 30' | 0.85 | 1.17 | 1.14 | 0.12 | - | - | - | 47 | |
| 10' x 7' | | 10 | 10 | 10 | 4 to 12 | 0.33' - <2' | 0.43 | 0.66 | 0.57 | 0.24 | 0.24 | 0.38 | 0.43 | - |
| | | | | | | 2' - <3' | 0.43 | 0.66 | 0.57 | 0.12 | - | - | - | 58 |
| | 3' - <5' | | | | | 0.38 | 0.59 | 0.55 | 0.12 | - | - | - | 58 | |
| | 5' - 10' | | | | | 0.37 | 0.50 | 0.54 | 0.12 | - | - | - | 52 | |
| | 10.5 | 10.5 | 10 | 8 to 12 | 15' | 0.52 | 0.66 | 0.65 | 0.12 | - | - | - | - | 47 |
| | | | | | 20' | 0.67 | 0.87 | 0.85 | 0.12 | - | - | - | 47 | |
| | | | | | 25' | 0.79 | 1.07 | 1.04 | 0.12 | - | - | - | 47 | |
| | | | | | 30' | 0.84 | 1.22 | 1.19 | 0.12 | - | - | - | 47 | |
| | 10' x 8' | 10 | 10 | 10 | 4 to 12 | 0.33' - <2' | 0.43 | 0.68 | 0.60 | 0.24 | 0.24 | 0.38 | 0.43 | - |
| | | | | | | 2' - <3' | 0.43 | 0.68 | 0.60 | 0.12 | - | - | - | 64 |
| 3' - <5' | | | | | | 0.38 | 0.62 | 0.57 | 0.12 | - | - | - | 58 | |
| 5' - 10' | | | | | | 0.38 | 0.52 | 0.57 | 0.12 | - | - | - | 52 | |
| 10.5 | | 10.5 | 10 | 8 to 12 | 15' | 0.53 | 0.69 | 0.68 | 0.12 | - | - | - | - | 47 |
| | | | | | 20' | 0.68 | 0.91 | 0.89 | 0.12 | - | - | - | 47 | |
| | | | | | 25' | 0.81 | 1.12 | 1.09 | 0.12 | - | - | - | 47 | |
| | | | | | 30' | 0.86 | 1.27 | 1.25 | 0.12 | - | - | - | 47 | |
| 10' x 9' | | 10 | 10 | 10 | 4 to 12 | 0.33' - <2' | 0.43 | 0.70 | 0.62 | 0.24 | 0.24 | 0.38 | 0.43 | - |
| | | | | | | 2' - <3' | 0.43 | 0.70 | 0.62 | 0.12 | - | - | - | 70 |
| | 3' - <5' | | | | | 0.39 | 0.64 | 0.60 | 0.12 | - | - | - | 64 | |
| | 5' - 10' | | | | | 0.40 | 0.54 | 0.59 | 0.12 | - | - | - | 58 | |
| | 10.5 | 11 | 10 | 8 to 12 | 15' | 0.56 | 0.72 | 0.72 | 0.12 | - | - | - | - | 52 |
| | | | | | 20' | 0.71 | 0.95 | 0.94 | 0.12 | - | - | - | 47 | |
| | | | | | 25' | 0.82 | 1.15 | 1.13 | 0.12 | - | - | - | 47 | |
| | | | | | 30' | 0.90 | 1.32 | 1.30 | 0.12 | - | - | - | 47 | |
| | 10' x 10' | 10 | 10 | 10 | 4 to 12 | 0.33' - <2' | 0.44 | 0.71 | 0.64 | 0.24 | 0.24 | 0.38 | 0.44 | - |
| | | | | | | 2' - <3' | 0.44 | 0.71 | 0.64 | 0.17 | - | - | - | 79 |
| 3' - <5' | | | | | | 0.40 | 0.65 | 0.62 | 0.16 | - | - | - | 70 | |
| 5' - 10' | | | | | | 0.44 | 0.56 | 0.61 | 0.15 | - | - | - | 64 | |
| 10.5 | | 11 | 10 | 8 to 12 | 15' | 0.60 | 0.75 | 0.76 | 0.12 | - | - | - | - | 52 |
| | | | | | 20' | 0.76 | 0.99 | 0.99 | 0.12 | - | - | - | 52 | |
| | | | | | 25' | 0.86 | 1.20 | 1.18 | 0.12 | - | - | - | 47 | |
| | | | | | 30' | 0.97 | 1.36 | 1.35 | 0.13 | - | - | - | 47 | |

NOTES:

1. See Sheet 1 for Reinforcing Details and dimension locations.
2. See Sheet 2 for General Notes.
3. See Sheet 14 for WWR Bending Diagram.

10/6/2022 10:51:18 AM

TABLE 7 - STANDARD PRECAST BOX CULVERT DESIGNS (2" COVER) - 11' SPANS

| SPAN x RISE (S) (R) (Ft.) | SLAB / WALL THICKNESS | | | | DESIGN EARTH COVER ABOVE TOP SLAB | REINFORCEMENT AREAS (sq. in./Ft.) | | | | | | | | As1 EXT. LENGTH (M) (in.) |
|------------------------------------|-----------------------|-----------------------|-----------------------|------------------------|--|--------------------------------------|------|------|------|------|------|------|------|------------------------------------|
| | TOP (Tt) (in.) | BOT. (Tb) (in.) | SIDE (Tw) (in.) | HAUNCH (H) (in.) | | As1 | As2 | As3 | As4 | As5 | As7 | As8 | As9 | |
| | | | | | | As1 | As2 | As3 | As4 | As5 | As7 | As8 | As9 | |
| 11' x 4' | 11 | 11 | 11 | 4 | 0.33' - <2' | 0.51 | 0.57 | 0.47 | 0.27 | 0.27 | 0.45 | 0.48 | - | |
| | | | | to | 2' - <3' | 0.51 | 0.57 | 0.47 | 0.14 | - | - | - | 62 | |
| | | | | 12 | 3' - <5' | 0.48 | 0.57 | 0.46 | 0.14 | - | - | - | 62 | |
| | | | | 12 | 5' - 10' | 0.47 | 0.50 | 0.50 | 0.14 | - | - | - | 55 | |
| | | | | 12 | 15' | 0.59 | 0.58 | 0.56 | 0.14 | - | - | - | 55 | |
| | 11.5 | 11.5 | 11 | 8 to | 25' | 0.92 | 0.95 | 0.91 | 0.14 | - | - | - | 55 | |
| | 13 | 13 | 11 | 12 | 30' | 0.94 | 1.09 | 1.06 | 0.14 | - | - | - | 55 | |
| | 11' x 6' | 11 | 11 | 11 | 4 | 0.33' - <2' | 0.45 | 0.62 | 0.52 | 0.27 | 0.27 | 0.41 | 0.45 | - |
| | | | | | to | 2' - <3' | 0.45 | 0.62 | 0.52 | 0.14 | - | - | - | 62 |
| | | | | | 12 | 3' - <5' | 0.42 | 0.58 | 0.51 | 0.14 | - | - | - | 55 |
| 12 | | | | | 5' - 10' | 0.43 | 0.56 | 0.56 | 0.14 | - | - | - | 55 | |
| 12 | | | | | 15' | 0.54 | 0.65 | 0.64 | 0.14 | - | - | - | 50 | |
| 11.5 | | 11.5 | 11 | 8 to | 25' | 0.83 | 1.07 | 1.03 | 0.14 | - | - | - | 50 | |
| 13 | | 13 | 11 | 12 | 30' | 0.85 | 1.22 | 1.19 | 0.14 | - | - | - | 50 | |
| 11' x 8' | | 11 | 11 | 11 | 4 | 0.33' - <2' | 0.42 | 0.67 | 0.57 | 0.27 | 0.27 | 0.39 | 0.43 | - |
| | | | | | to | 2' - <3' | 0.43 | 0.67 | 0.57 | 0.14 | - | - | - | 62 |
| | | | | | 12 | 3' - <5' | 0.39 | 0.63 | 0.56 | 0.14 | - | - | - | 62 |
| | 12 | | | | 5' - 10' | 0.43 | 0.60 | 0.61 | 0.14 | - | - | - | 55 | |
| | 12 | | | | 15' | 0.54 | 0.72 | 0.71 | 0.14 | - | - | - | 50 | |
| | 11.5 | 11.5 | 11 | 8 to | 25' | 0.82 | 1.16 | 1.13 | 0.14 | - | - | - | 50 | |
| | 13 | 13 | 11 | 12 | 30' | 0.86 | 1.32 | 1.30 | 0.14 | - | - | - | 50 | |
| | 11' x 10' | 11 | 11 | 11 | 4 | 0.33' - <2' | 0.44 | 0.71 | 0.62 | 0.27 | 0.27 | 0.38 | 0.44 | - |
| | | | | | to | 2' - <3' | 0.44 | 0.71 | 0.62 | 0.14 | - | - | - | 75 |
| | | | | | 12 | 3' - <5' | 0.41 | 0.67 | 0.61 | 0.14 | - | - | - | 69 |
| 12 | | | | | 5' - 10' | 0.47 | 0.64 | 0.66 | 0.14 | - | - | - | 62 | |
| 12 | | | | | 15' | 0.59 | 0.78 | 0.78 | 0.14 | - | - | - | 55 | |
| 11.5 | | 12 | 11 | 8 to | 25' | 0.85 | 1.24 | 1.22 | 0.14 | - | - | - | 50 | |
| 13 | | 13.5 | 11 | 12 | 30' | 0.91 | 1.40 | 1.39 | 0.14 | - | - | - | 50 | |
| 11' x 11' | | 11 | 11 | 11 | 4 | 0.33' - <2' | 0.45 | 0.72 | 0.64 | 0.27 | 0.27 | 0.39 | 0.45 | - |
| | | | | | to | 2' - <3' | 0.45 | 0.72 | 0.64 | 0.18 | - | - | - | 86 |
| | | | | | 12 | 3' - <5' | 0.42 | 0.69 | 0.63 | 0.18 | - | - | - | 75 |
| | 12 | | | | 5' - 10' | 0.51 | 0.66 | 0.69 | 0.16 | - | - | - | 69 | |
| | 12 | | | | 15' | 0.63 | 0.81 | 0.82 | 0.14 | - | - | - | 55 | |
| | 11.5 | 12 | 11 | 8 to | 25' | 0.91 | 1.29 | 1.27 | 0.14 | - | - | - | 55 | |
| | 13 | 13.5 | 11 | 12 | 30' | 0.99 | 1.44 | 1.44 | 0.14 | - | - | - | 50 | |

See General Note 5

TABLE 8 - STANDARD PRECAST BOX CULVERT DESIGNS (2" COVER) - 12' SPANS

| SPAN x RISE (S) (R) (Ft.) | SLAB / WALL THICKNESS | | | | DESIGN EARTH COVER ABOVE TOP SLAB | REINFORCEMENT AREAS (sq. in./Ft.) | | | | | | | | As1 EXT. LENGTH (M) (in.) |
|------------------------------------|-----------------------|-----------------------|-----------------------|------------------------|--|--------------------------------------|------|------|------|------|------|------|------|------------------------------------|
| | TOP (Tt) (in.) | BOT. (Tb) (in.) | SIDE (Tw) (in.) | HAUNCH (H) (in.) | | As1 | As2 | As3 | As4 | As5 | As7 | As8 | As9 | |
| | | | | | | As1 | As2 | As3 | As4 | As5 | As7 | As8 | As9 | |
| 12' x 4' | 12 | 12 | 12 | 4 | 0.33' - <2' | 0.52 | 0.57 | 0.45 | 0.29 | 0.29 | 0.47 | 0.49 | - | |
| | | | | to | 2' - <3' | 0.52 | 0.57 | 0.45 | 0.15 | - | - | - | 73 | |
| | | | | 12 | 3' - <5' | 0.50 | 0.54 | 0.45 | 0.15 | - | - | - | 66 | |
| | | | | 12 | 5' - 10' | 0.50 | 0.52 | 0.52 | 0.15 | - | - | - | 66 | |
| | | | | 12 | 15' | 0.63 | 0.61 | 0.59 | 0.15 | - | - | - | 59 | |
| | 12.5 | 12.5 | 12 | 8 to | 25' | 0.99 | 0.99 | 0.95 | 0.15 | - | - | - | 59 | |
| | 14 | 14 | 12 | 12 | 30' | 1.03 | 1.15 | 1.11 | 0.15 | - | - | - | 59 | |
| | 12' x 6' | 12 | 12 | 12 | 4 | 0.33' - <2' | 0.47 | 0.62 | 0.51 | 0.29 | 0.29 | 0.42 | 0.46 | - |
| | | | | | to | 2' - <3' | 0.47 | 0.62 | 0.51 | 0.15 | - | - | - | 66 |
| | | | | | 12 | 3' - <5' | 0.45 | 0.60 | 0.51 | 0.15 | - | - | - | 59 |
| 12 | | | | | 5' - 10' | 0.47 | 0.59 | 0.59 | 0.15 | - | - | - | 59 | |
| 12 | | | | | 15' | 0.57 | 0.68 | 0.66 | 0.15 | - | - | - | 53 | |
| 12.5 | | 12.5 | 12 | 8 to | 25' | 0.88 | 1.11 | 1.06 | 0.15 | - | - | - | 53 | |
| 14 | | 14.5 | 12 | 12 | 30' | 0.92 | 1.27 | 1.24 | 0.15 | - | - | - | 53 | |
| 12' x 8' | | 12 | 12 | 12 | 4 | 0.33' - <2' | 0.44 | 0.67 | 0.56 | 0.29 | 0.29 | 0.40 | 0.44 | - |
| | | | | | to | 2' - <3' | 0.44 | 0.67 | 0.56 | 0.15 | - | - | - | 66 |
| | | | | | 12 | 3' - <5' | 0.41 | 0.64 | 0.56 | 0.15 | - | - | - | 59 |
| | 12 | | | | 5' - 10' | 0.45 | 0.63 | 0.64 | 0.15 | - | - | - | 59 | |
| | 12 | | | | 15' | 0.56 | 0.75 | 0.73 | 0.15 | - | - | - | 53 | |
| | 12.5 | 13 | 12 | 8 to | 25' | 0.85 | 1.20 | 1.16 | 0.15 | - | - | - | 53 | |
| | 14 | 14.5 | 12 | 12 | 30' | 0.89 | 1.38 | 1.35 | 0.15 | - | - | - | 53 | |
| | 12' x 10' | 12 | 12 | 12 | 4 | 0.33' - <2' | 0.44 | 0.71 | 0.60 | 0.29 | 0.29 | 0.39 | 0.44 | - |
| | | | | | to | 2' - <3' | 0.44 | 0.71 | 0.60 | 0.15 | - | - | - | 73 |
| | | | | | 12 | 3' - <5' | 0.42 | 0.68 | 0.60 | 0.15 | - | - | - | 66 |
| 12 | | | | | 5' - 10' | 0.47 | 0.67 | 0.69 | 0.15 | - | - | - | 59 | |
| 12 | | | | | 15' | 0.59 | 0.81 | 0.81 | 0.15 | - | - | - | 53 | |
| 12.5 | | 13 | 12 | 8 to | 25' | 0.87 | 1.30 | 1.26 | 0.15 | - | - | - | 53 | |
| 14 | | 14.5 | 12 | 12 | 30' | 0.92 | 1.47 | 1.45 | 0.15 | - | - | - | 53 | |
| 12' x 12' | | 12 | 12 | 12 | 4 | 0.33' - <2' | 0.46 | 0.74 | 0.64 | 0.29 | 0.29 | 0.40 | 0.46 | - |
| | | | | | to | 2' - <3' | 0.46 | 0.74 | 0.64 | 0.20 | - | - | - | 93 |
| | | | | | 12 | 3' - <5' | 0.42 | 0.72 | 0.64 | 0.20 | - | - | - | 80 |
| | 12 | | | | 5' - 10' | 0.54 | 0.71 | 0.74 | 0.18 | - | - | - | 73 | |
| | 12 | | | | 15' | 0.66 | 0.87 | 0.89 | 0.15 | - | - | - | 59 | |
| | 12.5 | 13 | 12 | 8 to | 25' | 0.83 | 1.14 | 1.13 | 0.15 | - | - | - | 59 | |
| | 14 | 14.5 | 12.5 | 12 | 30' | 0.96 | 1.39 | 1.37 | 0.15 | - | - | - | 53 | |
| | 14 | 14.5 | 12.5 | 12 | 30' | 1.05 | 1.56 | 1.56 | 0.15 | - | - | - | 53 | |

See General Note 5

NOTES:

1. See Sheet 1 for Reinforcing Details and dimension locations.
2. See Sheet 2 for General Notes.
3. See Sheet 14 for Welded Wire Reinforcement Bending Diagram.

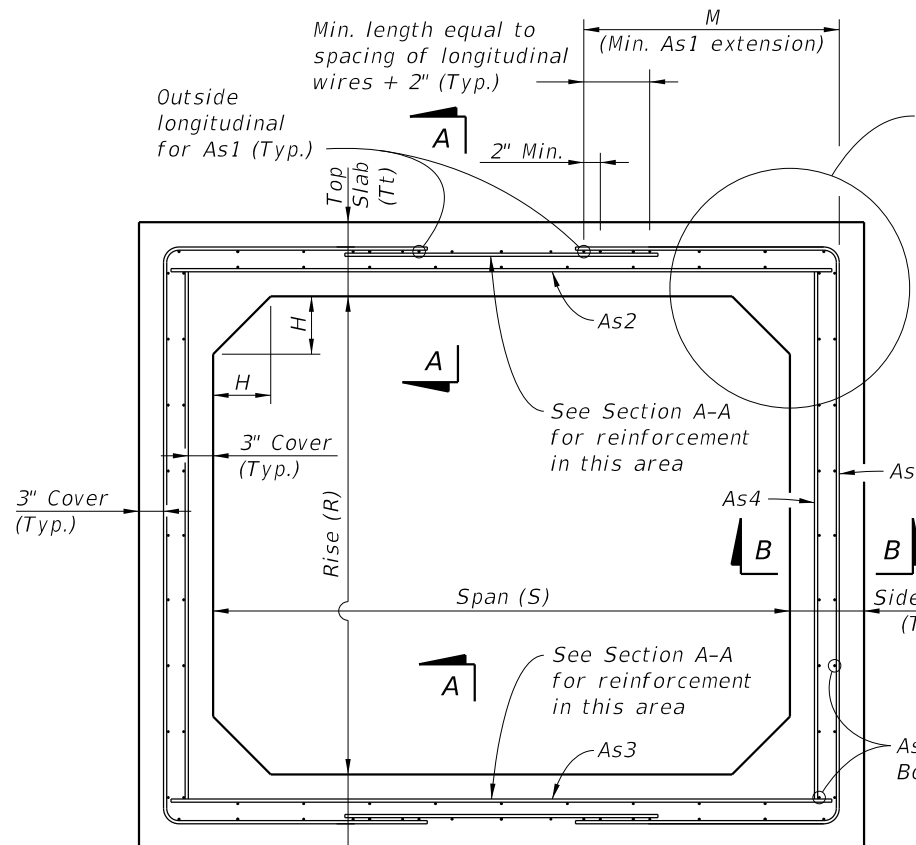

TYPICAL BOX SECTION (TYPE 2)
DESIGN EARTH COVER 2' OR GREATER
 (Option 1 Reinforcing Configuration Shown)

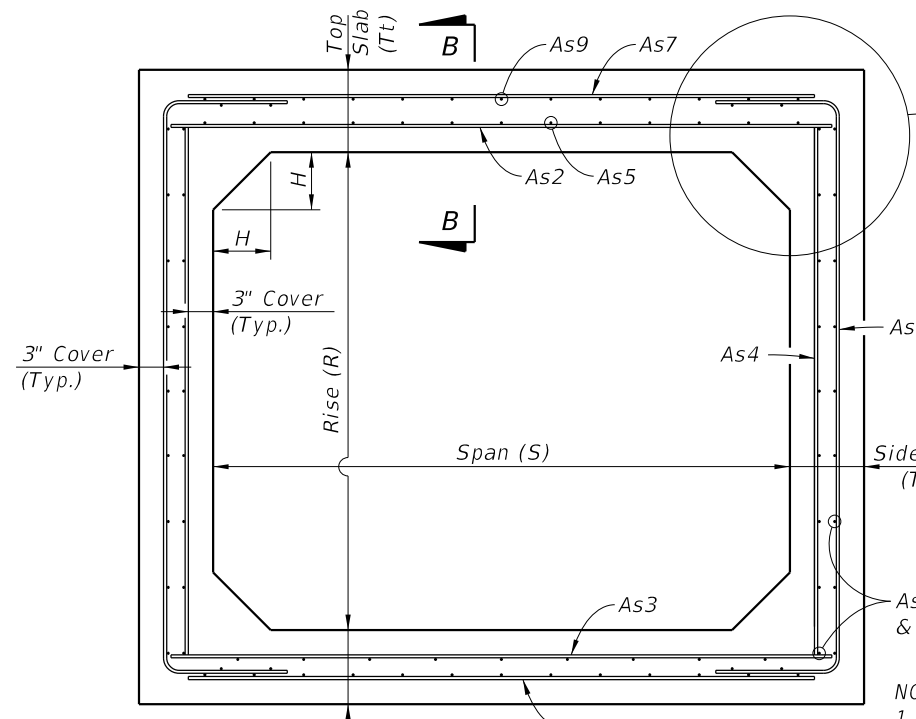

TYPICAL BOX SECTION (TYPE 1)
DESIGN EARTH COVER LESS THAN 2'
 (Option 1 Reinforcing Configuration Shown)

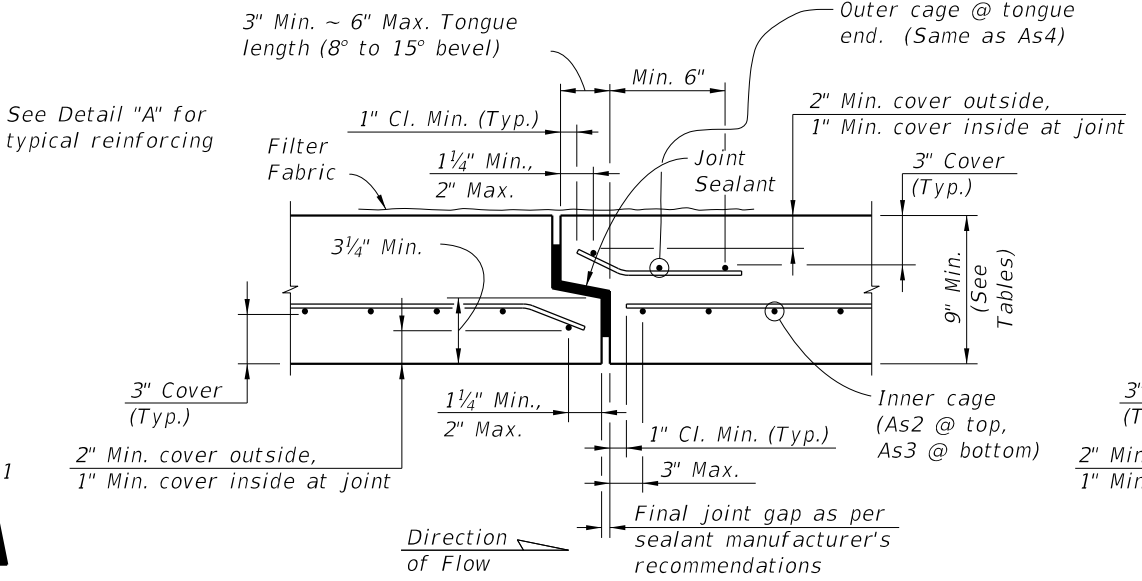

SECTION A-A

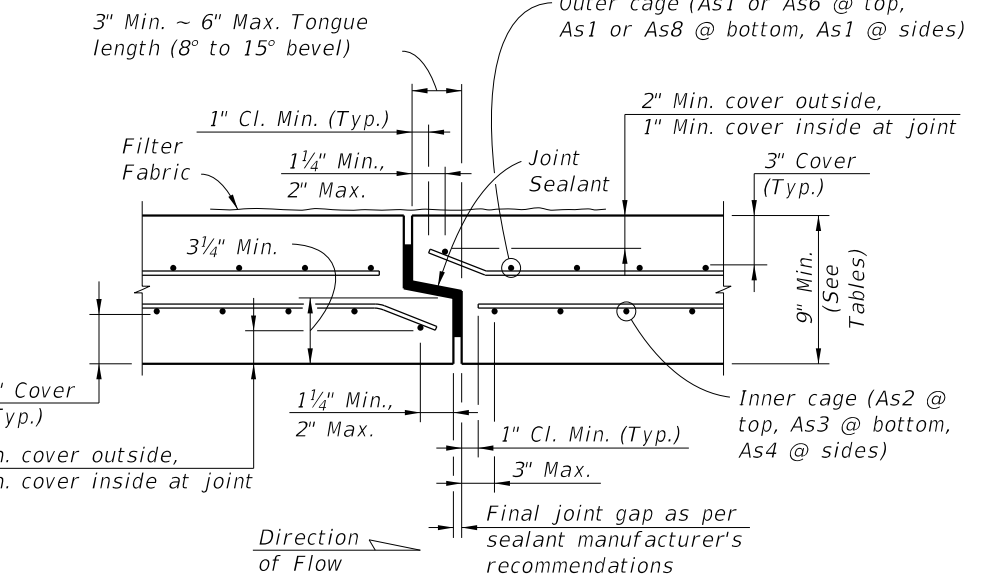

SECTION B-B
TYPICAL SECTION THRU JOINT

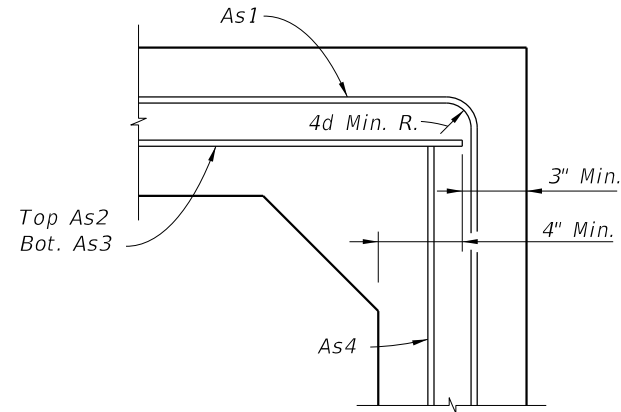

DETAIL "A"
(OPTION 1)

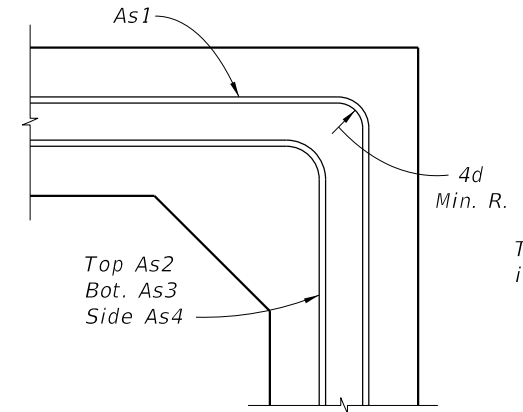

DETAIL "A"
(OPTION 2)

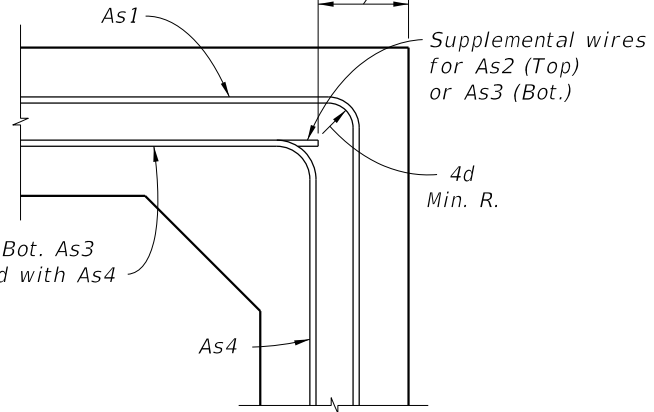

DETAIL "A"
(OPTION 3)

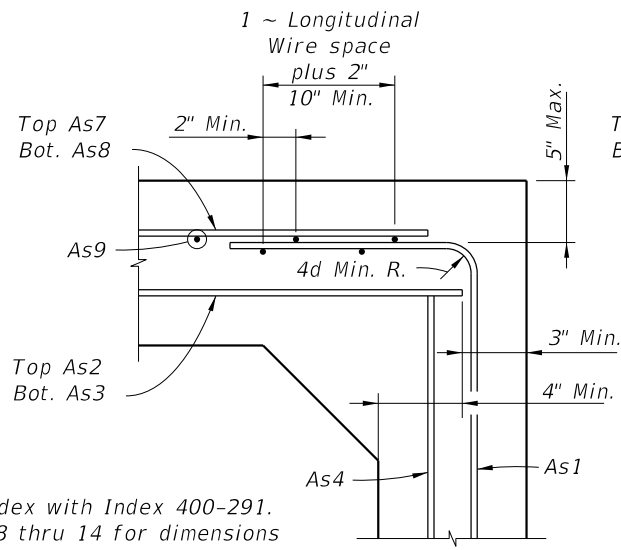

DETAIL "B"
(OPTION 1)

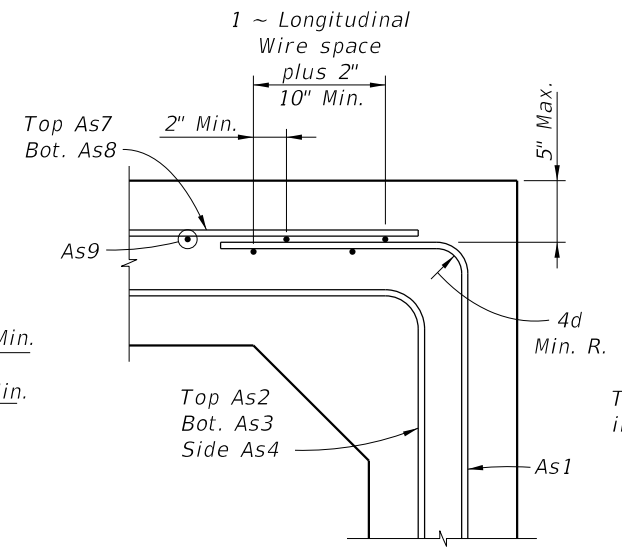

DETAIL "B"
(OPTION 2)

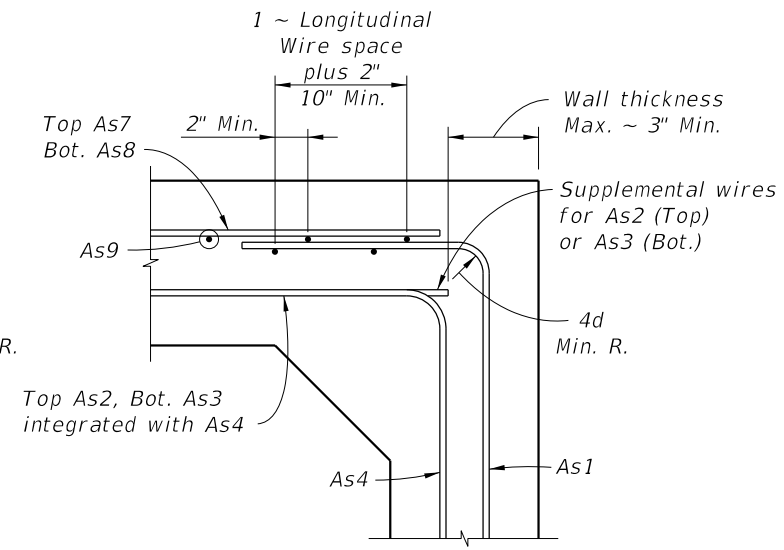

DETAIL "B"
(OPTION 3)

- NOTES:**
 1. Work this Index with Index 400-291.
 2. See Sheets 8 thru 14 for dimensions and areas of reinforcement.

STANDARD PRECAST BOX CULVERT WITH 3" CONCRETE COVER

10/6/2022 10:51:19 AM

| | | | | | | | |
|---------------------------|----------|--------------|--|------------------------------|--|------------------|------------------|
| LAST REVISION 07/01/13 | REVISION | DESCRIPTION: | | FY 2023-24 STANDARD PLANS | STANDARD PRECAST CONCRETE BOX CULVERTS | INDEX 400-292 | SHEET 7 of 14 |
|---------------------------|----------|--------------|--|------------------------------|--|------------------|------------------|

TABLE 9A - STANDARD PRECAST BOX CULVERT DESIGNS (3" COVER) - 3' & 4' SPANS

| SPAN x RISE (S) (R) (Ft.) | SLAB / WALL THICKNESS | | | | DESIGN EARTH COVER ABOVE TOP SLAB | REINFORCEMENT AREAS (sq. in./Ft.) | | | | | | | | | As1 EXT. LENGTH (M) (in.) | | | |
|---------------------------------|-----------------------|-----------------------|-----------------------|------------------------|--|--------------------------------------|------|------|--------------|-------------|------|------|------|------|------------------------------------|------|------|----|
| | TOP (Tt) (in.) | BOT. (Tb) (in.) | SIDE (Tw) (in.) | HAUNCH (H) (in.) | | As1 | As2 | As3 | As4 | As5 | As7 | As8 | As9 | | | | | |
| | | | | | | See General Note 5 | | | | | | | | | | | | |
| 3' x 3' | 9 | 9 | 9 | 4 to 8 | 0.33' - <2' | 0.22 | 0.24 | 0.22 | 0.22 | 0.22 | 0.22 | 0.22 | - | | | | | |
| | | | | | 2' - <3' | 0.11 | 0.23 | 0.22 | 0.11 | - | - | - | 31 | | | | | |
| | | | | | 3' - <5' | 0.11 | 0.22 | 0.22 | 0.11 | - | - | - | 31 | | | | | |
| | | | | | 5' - 10' | 0.11 | 0.22 | 0.22 | 0.11 | - | - | - | 31 | | | | | |
| | | | | | 15' | 0.11 | 0.22 | 0.22 | 0.11 | - | - | - | 31 | | | | | |
| | | | | | 20' | 0.13 | 0.22 | 0.22 | 0.11 | - | - | - | 31 | | | | | |
| | | | | | 25' | 0.16 | 0.22 | 0.22 | 0.11 | - | - | - | 31 | | | | | |
| | | | | | 30' | 0.19 | 0.24 | 0.25 | 0.11 | - | - | - | 31 | | | | | |
| | | | | | 35' | 0.22 | 0.28 | 0.29 | 0.11 | - | - | - | 31 | | | | | |
| | | | | | 4' x 3' | 9 | 9 | 9 | 4 to 8 | 0.33' - <2' | 0.22 | 0.32 | 0.24 | 0.22 | 0.22 | 0.22 | 0.22 | - |
| 2' - <3' | 0.17 | 0.31 | 0.24 | 0.11 | | | | | | - | - | - | 38 | | | | | |
| 3' - <5' | 0.13 | 0.22 | 0.22 | 0.11 | | | | | | - | - | - | 38 | | | | | |
| 5' - 10' | 0.13 | 0.22 | 0.22 | 0.11 | | | | | | - | - | - | 38 | | | | | |
| 15' | 0.17 | 0.22 | 0.22 | 0.11 | | | | | | - | - | - | 38 | | | | | |
| 20' | 0.23 | 0.26 | 0.27 | 0.11 | | | | | | - | - | - | 38 | | | | | |
| 25' | 0.28 | 0.32 | 0.34 | 0.11 | | | | | | - | - | - | 38 | | | | | |
| 30' | 0.33 | 0.39 | 0.40 | 0.11 | | | | | | - | - | - | 38 | | | | | |
| 4' x 4' | 9 | 9 | 9 | 4 to 8 | | | | | | 0.33' - <2' | 0.22 | 0.34 | 0.26 | 0.22 | 0.22 | 0.22 | 0.22 | - |
| | | | | | | | | | | 2' - <3' | 0.17 | 0.33 | 0.26 | 0.11 | - | - | - | 38 |
| | | | | | 3' - <5' | 0.13 | 0.22 | 0.22 | 0.11 | - | - | - | 38 | | | | | |
| | | | | | 5' - 10' | 0.14 | 0.22 | 0.22 | 0.11 | - | - | - | 38 | | | | | |
| | | | | | 15' | 0.19 | 0.22 | 0.23 | 0.11 | - | - | - | 38 | | | | | |
| | | | | | 20' | 0.24 | 0.28 | 0.30 | 0.11 | - | - | - | 38 | | | | | |
| | | | | | 25' | 0.29 | 0.36 | 0.37 | 0.11 | - | - | - | 38 | | | | | |
| | | | | | 30' | 0.34 | 0.43 | 0.45 | 0.11 | - | - | - | 38 | | | | | |

TABLE 9B - STANDARD PRECAST BOX CULVERT DESIGNS (3" COVER) - 3' & 4' SPANS

| SPAN x RISE (S) (R) (Ft.) | SLAB / WALL THICKNESS | | | | DESIGN EARTH COVER ABOVE TOP SLAB | REINFORCEMENT AREAS (sq. in./Ft.) | | | | | | | | | As1 EXT. LENGTH (M) (in.) | | | |
|---------------------------------|-----------------------|-----------------------|-----------------------|------------------------|--|--------------------------------------|------|------|--------------|-------------|------|------|------|------|------------------------------------|------|------|----|
| | TOP (Tt) (in.) | BOT. (Tb) (in.) | SIDE (Tw) (in.) | HAUNCH (H) (in.) | | As1 | As2 | As3 | As4 | As5 | As7 | As8 | As9 | | | | | |
| | | | | | | See General Note 5 | | | | | | | | | | | | |
| 3' x 3' | 10 | 10 | 10 | 4 to 8 | 0.33' - <2' | 0.24 | 0.24 | 0.24 | 0.24 | 0.24 | 0.24 | 0.24 | - | | | | | |
| | | | | | 2' - <3' | 0.12 | 0.24 | 0.24 | 0.24 | - | - | - | 31 | | | | | |
| | | | | | 3' - <5' | 0.12 | 0.24 | 0.24 | 0.24 | - | - | - | 31 | | | | | |
| | | | | | 5' - 10' | 0.12 | 0.24 | 0.24 | 0.24 | - | - | - | 31 | | | | | |
| | | | | | 15' | 0.12 | 0.24 | 0.24 | 0.24 | - | - | - | 31 | | | | | |
| | | | | | 20' | 0.12 | 0.24 | 0.24 | 0.24 | - | - | - | 31 | | | | | |
| | | | | | 25' | 0.13 | 0.24 | 0.24 | 0.24 | - | - | - | 31 | | | | | |
| | | | | | 30' | 0.15 | 0.24 | 0.24 | 0.12 | - | - | - | 31 | | | | | |
| | | | | | 35' | 0.18 | 0.24 | 0.24 | 0.12 | - | - | - | 31 | | | | | |
| | | | | | 4' x 3' | 10 | 10 | 10 | 4 to 8 | 0.33' - <2' | 0.24 | 0.26 | 0.24 | 0.24 | 0.24 | 0.24 | 0.24 | - |
| 2' - <3' | 0.14 | 0.26 | 0.24 | 0.12 | | | | | | - | - | - | 38 | | | | | |
| 3' - <5' | 0.12 | 0.24 | 0.24 | 0.12 | | | | | | - | - | - | 38 | | | | | |
| 5' - 10' | 0.12 | 0.24 | 0.24 | 0.12 | | | | | | - | - | - | 38 | | | | | |
| 15' | 0.14 | 0.24 | 0.24 | 0.12 | | | | | | - | - | - | 38 | | | | | |
| 20' | 0.18 | 0.24 | 0.24 | 0.12 | | | | | | - | - | - | 38 | | | | | |
| 25' | 0.22 | 0.26 | 0.27 | 0.12 | | | | | | - | - | - | 38 | | | | | |
| 30' | 0.26 | 0.31 | 0.32 | 0.12 | | | | | | - | - | - | 38 | | | | | |
| 4' x 4' | 10 | 10 | 10 | 4 to 8 | | | | | | 0.33' - <2' | 0.24 | 0.28 | 0.24 | 0.24 | 0.24 | 0.24 | 0.24 | - |
| | | | | | | | | | | 2' - <3' | 0.14 | 0.28 | 0.24 | 0.12 | - | - | - | 38 |
| | | | | | 3' - <5' | 0.12 | 0.24 | 0.24 | 0.12 | - | - | - | 38 | | | | | |
| | | | | | 5' - 10' | 0.12 | 0.24 | 0.24 | 0.12 | - | - | - | 38 | | | | | |
| | | | | | 15' | 0.15 | 0.24 | 0.24 | 0.12 | - | - | - | 38 | | | | | |
| | | | | | 20' | 0.19 | 0.24 | 0.24 | 0.12 | - | - | - | 38 | | | | | |
| | | | | | 25' | 0.23 | 0.28 | 0.30 | 0.12 | - | - | - | 38 | | | | | |
| | | | | | 30' | 0.27 | 0.34 | 0.35 | 0.12 | - | - | - | 38 | | | | | |

NOTES:

1. See Sheet 2 for General Notes.
2. See Sheet 7 for Reinforcing Details and dimension locations.
3. See Sheet 14 for WWR Bending Diagrams.

10/6/2022 10:51:20 AM

10/6/2022 10:51:20 AM

| TABLE 10A - STANDARD PRECAST BOX CULVERT DESIGNS (3" COVER) - 5' & 6' SPANS | | | | | | | | | | | | | | |
|---|-----------------------|-----------------------|-----------------------|------------------------|--|--------------------------------------|------|------|------|------|------|------|-----|------------------------------------|
| SPAN x RISE (S) (R) (Ft.) | SLAB / WALL THICKNESS | | | | DESIGN EARTH COVER ABOVE TOP SLAB | REINFORCEMENT AREAS (sq. in./Ft.) | | | | | | | | As1 EXT. LENGTH (M) (in.) |
| | TOP (Tt) (in.) | BOT. (Tb) (in.) | SIDE (Tw) (in.) | HAUNCH (H) (in.) | | As1 | As2 | As3 | As4 | As5 | As7 | As8 | As9 | |
| 5' x 3' | 9 | 9 | 9 | 4 | 0.33' - <2' | 0.27 | 0.39 | 0.37 | 0.22 | 0.22 | 0.22 | 0.27 | - | |
| | | | | | 2' - <3' | 0.26 | 0.39 | 0.37 | 0.11 | - | - | - | 45 | |
| | | | | | 3' - <5' | 0.19 | 0.24 | 0.25 | 0.11 | - | - | - | 36 | |
| | | | | | 5' - 10' | 0.20 | 0.22 | 0.22 | 0.11 | - | - | - | 36 | |
| | | | | 8 | 15' | 0.28 | 0.28 | 0.30 | 0.11 | - | - | - | 35 | |
| | | | | | 20' | 0.37 | 0.38 | 0.39 | 0.11 | - | - | - | 35 | |
| | | | | | 25' | 0.45 | 0.48 | 0.49 | 0.11 | - | - | - | 35 | |
| | | | | | 30' | 0.54 | 0.58 | 0.59 | 0.11 | - | - | - | 35 | |
| 5' x 4' | 9 | 9 | 9 | 4 | 0.33' - <2' | 0.26 | 0.42 | 0.39 | 0.22 | 0.22 | 0.22 | 0.26 | - | |
| | | | | | 2' - <3' | 0.26 | 0.42 | 0.39 | 0.11 | - | - | - | 45 | |
| | | | | | 3' - <5' | 0.19 | 0.26 | 0.27 | 0.11 | - | - | - | 45 | |
| | | | | | 5' - 10' | 0.20 | 0.22 | 0.23 | 0.11 | - | - | - | 36 | |
| | | | | 8 | 15' | 0.27 | 0.31 | 0.33 | 0.11 | - | - | - | 35 | |
| | | | | | 20' | 0.36 | 0.42 | 0.43 | 0.11 | - | - | - | 35 | |
| | | | | | 25' | 0.44 | 0.52 | 0.54 | 0.11 | - | - | - | 35 | |
| | | | | | 30' | 0.53 | 0.63 | 0.65 | 0.11 | - | - | - | 35 | |
| 5' x 5' | 9 | 9 | 9 | 4 | 0.33' - <2' | 0.27 | 0.44 | 0.42 | 0.22 | 0.22 | 0.22 | 0.27 | - | |
| | | | | | 2' - <3' | 0.27 | 0.44 | 0.42 | 0.11 | - | - | - | 45 | |
| | | | | | 3' - <5' | 0.20 | 0.27 | 0.28 | 0.11 | - | - | - | 45 | |
| | | | | | 5' - 10' | 0.22 | 0.23 | 0.26 | 0.11 | - | - | - | 45 | |
| | | | | 8 | 15' | 0.30 | 0.34 | 0.36 | 0.11 | - | - | - | 36 | |
| | | | | | 20' | 0.38 | 0.45 | 0.47 | 0.11 | - | - | - | 35 | |
| | | | | | 25' | 0.47 | 0.56 | 0.59 | 0.11 | - | - | - | 35 | |
| | | | | | 30' | 0.55 | 0.68 | 0.71 | 0.11 | - | - | - | 35 | |
| 6' x 3' | 9 | 9 | 9 | 4 | 0.33' - <2' | 0.34 | 0.47 | 0.42 | 0.22 | 0.22 | 0.25 | 0.34 | - | |
| | | | | | 2' - <3' | 0.34 | 0.47 | 0.42 | 0.11 | - | - | - | 43 | |
| | | | | | 3' - <5' | 0.27 | 0.31 | 0.32 | 0.11 | - | - | - | 39 | |
| | | | | | 5' - 10' | 0.29 | 0.26 | 0.28 | 0.11 | - | - | - | 39 | |
| | | | | 12 | 15' | 0.42 | 0.39 | 0.40 | 0.11 | - | - | - | 38 | |
| | | | | | 20' | 0.55 | 0.52 | 0.53 | 0.11 | - | - | - | 38 | |
| | | | | | 25' | 0.68 | 0.66 | 0.67 | 0.11 | - | - | - | 38 | |
| | | | | | 30' | 0.82 | 0.81 | 0.82 | 0.11 | - | - | - | 38 | |
| 6' x 4' | 9 | 9 | 9 | 4 | 0.33' - <2' | 0.33 | 0.50 | 0.46 | 0.22 | 0.22 | 0.23 | 0.33 | - | |
| | | | | | 2' - <3' | 0.33 | 0.50 | 0.46 | 0.11 | - | - | - | 43 | |
| | | | | | 3' - <5' | 0.27 | 0.33 | 0.35 | 0.11 | - | - | - | 39 | |
| | | | | | 5' - 10' | 0.28 | 0.29 | 0.31 | 0.11 | - | - | - | 39 | |
| | | | | 12 | 15' | 0.40 | 0.43 | 0.45 | 0.11 | - | - | - | 38 | |
| | | | | | 20' | 0.52 | 0.57 | 0.59 | 0.11 | - | - | - | 38 | |
| | | | | | 25' | 0.65 | 0.73 | 0.74 | 0.11 | - | - | - | 38 | |
| | | | | | 30' | 0.78 | 0.88 | 0.90 | 0.11 | - | - | - | 38 | |
| 6' x 5' | 9 | 9 | 9 | 4 | 0.33' - <2' | 0.33 | 0.52 | 0.49 | 0.22 | 0.22 | 0.23 | 0.33 | - | |
| | | | | | 2' - <3' | 0.33 | 0.52 | 0.49 | 0.11 | - | - | - | 43 | |
| | | | | | 3' - <5' | 0.27 | 0.35 | 0.37 | 0.11 | - | - | - | 43 | |
| | | | | | 5' - 10' | 0.29 | 0.31 | 0.34 | 0.11 | - | - | - | 39 | |
| | | | | 12 | 15' | 0.41 | 0.46 | 0.49 | 0.11 | - | - | - | 38 | |
| | | | | | 20' | 0.53 | 0.62 | 0.64 | 0.11 | - | - | - | 38 | |
| | | | | | 25' | 0.66 | 0.78 | 0.80 | 0.11 | - | - | - | 38 | |
| | | | | | 30' | 0.78 | 0.95 | 0.97 | 0.11 | - | - | - | 38 | |
| 6' x 6' | 9 | 9 | 9 | 4 | 0.33' - <2' | 0.34 | 0.55 | 0.51 | 0.22 | 0.22 | 0.24 | 0.34 | - | |
| | | | | | 2' - <3' | 0.34 | 0.54 | 0.51 | 0.11 | - | - | - | 52 | |
| | | | | | 3' - <5' | 0.29 | 0.37 | 0.39 | 0.11 | - | - | - | 52 | |
| | | | | | 5' - 10' | 0.32 | 0.34 | 0.37 | 0.11 | - | - | - | 43 | |
| | | | | 12 | 15' | 0.44 | 0.50 | 0.53 | 0.11 | - | - | - | 39 | |
| | | | | | 20' | 0.57 | 0.66 | 0.70 | 0.11 | - | - | - | 39 | |
| | | | | | 25' | 0.70 | 0.84 | 0.87 | 0.11 | - | - | - | 38 | |
| | | | | | 30' | 0.83 | 1.02 | 1.05 | 0.11 | - | - | - | 38 | |

See General Note 5

See General Note 5

| TABLE 10B - STANDARD PRECAST BOX CULVERT DESIGNS (3" COVER) - 5' & 6' SPANS | | | | | | | | | | | | | | |
|---|-----------------------|-----------------------|-----------------------|------------------------|--|--------------------------------------|------|------|------|------|------|------|-----|------------------------------------|
| SPAN x RISE (S) (R) (Ft.) | SLAB / WALL THICKNESS | | | | DESIGN EARTH COVER ABOVE TOP SLAB | REINFORCEMENT AREAS (sq. in./Ft.) | | | | | | | | As1 EXT. LENGTH (M) (in.) |
| | TOP (Tt) (in.) | BOT. (Tb) (in.) | SIDE (Tw) (in.) | HAUNCH (H) (in.) | | As1 | As2 | As3 | As4 | As5 | As7 | As8 | As9 | |
| 5' x 3' | 10 | 10 | 10 | 4 | 0.33' - <2' | 0.24 | 0.33 | 0.32 | 0.24 | 0.24 | 0.24 | 0.24 | - | |
| | | | | | 2' - <3' | 0.22 | 0.33 | 0.32 | 0.12 | - | - | - | 45 | |
| | | | | | 3' - <5' | 0.16 | 0.24 | 0.24 | 0.12 | - | - | - | 36 | |
| | | | | | 5' - 10' | 0.16 | 0.24 | 0.24 | 0.12 | - | - | - | 36 | |
| | | | | 12 | 15' | 0.23 | 0.24 | 0.24 | 0.12 | - | - | - | 35 | |
| | | | | | 20' | 0.29 | 0.30 | 0.31 | 0.12 | - | - | - | 35 | |
| | | | | | 25' | 0.36 | 0.38 | 0.39 | 0.12 | - | - | - | 35 | |
| | | | | | 30' | 0.43 | 0.46 | 0.47 | 0.12 | - | - | - | 35 | |
| 5' x 4' | 10 | 10 | 10 | 4 | 0.33' - <2' | 0.24 | 0.35 | 0.34 | 0.24 | 0.24 | 0.24 | 0.24 | - | |
| | | | | | 2' - <3' | 0.22 | 0.35 | 0.34 | 0.12 | - | - | - | 45 | |
| | | | | | 3' - <5' | 0.15 | 0.24 | 0.24 | 0.12 | - | - | - | 45 | |
| | | | | | 5' - 10' | 0.16 | 0.24 | 0.24 | 0.12 | - | - | - | 36 | |
| | | | | 12 | 15' | 0.22 | 0.25 | 0.27 | 0.12 | - | - | - | 35 | |
| | | | | | 20' | 0.29 | 0.33 | 0.34 | 0.12 | - | - | - | 35 | |
| | | | | | 25' | 0.36 | 0.41 | 0.43 | 0.12 | - | - | - | 35 | |
| | | | | | 30' | 0.42 | 0.50 | 0.51 | 0.12 | - | - | - | 35 | |
| 5' x 5' | 10 | 10 | 10 | 4 | 0.33' - <2' | 0.24 | 0.37 | 0.36 | 0.24 | 0.24 | 0.24 | 0.24 | - | |
| | | | | | 2' - <3' | 0.21 | 0.37 | 0.36 | 0.12 | - | - | - | 45 | |
| | | | | | 3' - <5' | 0.16 | 0.24 | 0.25 | 0.12 | - | - | - | 45 | |
| | | | | | 5' - 10' | 0.17 | 0.24 | 0.24 | 0.12 | - | - | - | 45 | |
| | | | | 12 | 15' | 0.24 | 0.27 | 0.29 | 0.12 | - | - | - | 36 | |
| | | | | | 20' | 0.30 | 0.36 | 0.38 | 0.12 | - | - | - | 35 | |
| | | | | | 25' | 0.37 | 0.44 | 0.47 | 0.12 | - | - | - | 35 | |
| | | | | | 30' | 0.44 | 0.53 | 0.56 | 0.12 | - | - | - | 35 | |
| 6' x 3' | 10 | 10 | 10 | 4 | 0.33' - <2' | 0.28 | 0.40 | 0.36 | 0.24 | 0.24 | 0.24 | 0.28 | - | |
| | | | | | 2' - <3' | 0.28 | 0.40 | 0.36 | 0.12 | - | - | - | 43 | |
| | | | | | 3' - <5' | 0.22 | 0.26 | 0.28 | 0.12 | - | - | - | 39 | |
| | | | | | 5' - 10' | 0.24 | 0.24 | 0.24 | 0.12 | - | - | - | 39 | |
| | | | | 12 | 15' | 0.34 | 0.31 | 0.32 | 0.12 | - | - | - | 38 | |
| | | | | | 20' | 0.44 | 0.41 | 0.42 | 0.12 | - | - | - | 38 | |
| | | | | | 25' | 0.54 | 0.52 | 0.53 | 0.12 | - | - | - | 38 | |
| | | | | | 30' | 0.64 | 0.63 | 0.64 | 0.12 | - | - | - | 38 | |
| 6' x 4' | 10 | 10 | 10 | 4 | 0.33' - <2' | 0.27 | 0.42 | 0.39 | 0.24 | 0.24 | 0.24 | 0.27 | - | |
| | | | | | 2' - <3' | 0.27 | 0.42 | 0.39 | 0.12 | - | - | - | 43 | |
| | | | | | 3' - <5' | 0.21 | 0.28 | 0.30 | 0.12 | - | - | - | 39 | |
| | | | | | 5' - 10' | 0.23 | 0.24 | 0.25 | 0.12 | - | - | - | 39 | |
| | | | | 12 | 15' | 0.32 | 0.34 | 0.35 | 0.12 | - | - | - | 38 | |
| | | | | | 20' | 0.42 | 0.45 | 0.47 | 0.12 | - | - | - | 38 | |
| | | | | | 25' | 0.51 | 0.56 | 0.58 | 0.12 | - | - | - | 38 | |
| | | | | | 30' | 0.61 | 0.68 | 0.70 | 0.12 | - | - | - | 38 | |
| 6' x 5' | 10 | 10 | 10 | 4 | 0.33' - <2' | 0.26 | 0.44 | 0.42 | 0.24 | 0.24 | 0.24 | 0.26 | - | |
| | | | | | 2' - <3' | 0.26 | 0.44 | 0.42 | 0.12 | - | - | - | 43 | |
| | | | | | 3' - <5' | 0.22 | 0.30 | 0.33 | 0.12 | - | - | - | 43 | |
| | | | | | 5' - 10' | 0.24 | 0.25 | 0.27 | 0.12 | - | - | - | 39 | |
| | | | | 12 | 15' | 0.33 | 0.36 | 0.39 | 0.12 | - | - | - | 38 | |
| | | | | | 20' | 0.42 | 0.48 | 0.51 | 0.12 | - | - | - | 38 | |
| | | | | | 25' | 0.52 | 0.61 | 0.63 | 0.12 | - | - | - | 38 | |
| | | | | | 30' | 0.61 | 0.74 | 0.76 | 0.12 | - | - | - | 38 | |
| 6' x 6' | 10 | 10 | 10 | 4 | 0.33' - <2' | 0.27 | 0.46 | 0.44 | 0.24 | 0.24 | 0.24 | 0.27 | - | |
| | | | | | 2' - <3' | 0.27 | 0.46 | 0.44 | 0.12 | - | - | - | 52 | |
| | | | | | 3' - <5' | 0.23 | 0.31 | 0.34 | 0.12 | - | - | - | 52 | |
| | | | | | 5' - 10' | 0.25 | 0.27 | 0.30 | 0.12 | - | - | - | 43 | |
| | | | | 12 | 15' | 0.35 | 0.39 | 0.42 | 0.12 | - | - | - | 39 | |
| | | | | | 20' | 0.45 | 0.52 | 0.55 | 0.12 | - | - | - | 39 | |
| | | | | | 25' | 0.54 | 0.65 | 0.68 | 0.12 | - | - | - | 38 | |
| | | | | | 30' | 0.64 | 0.78 | 0.81 | 0.12 | - | - | - | 38 | |

10/6/2022 10:51:21 AM

TABLE 11A - STANDARD PRECAST BOX CULVERT DESIGNS (3" COVER) - 7' SPANS

| SPAN x RISE (S) (R) (Ft.) | SLAB / WALL THICKNESS | | | | DESIGN EARTH COVER ABOVE TOP SLAB | REINFORCEMENT AREAS (sq. in./Ft.) | | | | | | | | As1 EXT. LENGTH (M) (in.) |
|---------------------------------|-----------------------|-----------------------|-----------------------|------------------------|--|--------------------------------------|------|------|------|------|------|------|-----|------------------------------------|
| | TOP (Tt) (in.) | BOT. (Tb) (in.) | SIDE (Tw) (in.) | HAUNCH (H) (in.) | | As1 | As2 | As3 | As4 | As5 | As7 | As8 | As9 | |
| | | | | | | See General Note 5 | | | | | | | | |
| 7' x 4' | 9 | 9 | 9 | 4 to 12 | 0.33' - <2' | 0.42 | 0.58 | 0.52 | 0.22 | 0.22 | 0.31 | 0.42 | - | |
| | | | | | 2' - <3' | 0.42 | 0.58 | 0.51 | 0.11 | - | - | - | 43 | |
| | | | | | 3' - <5' | 0.36 | 0.41 | 0.44 | 0.11 | - | - | - | 43 | |
| | | | | | 5' - 10' | 0.39 | 0.40 | 0.39 | 0.11 | - | - | - | 43 | |
| | | | | | 15' | 0.56 | 0.56 | 0.58 | 0.11 | - | - | - | 41 | |
| | 9 | 9.5 | 9 | 7 to 12 | 20' | 0.74 | 0.76 | 0.77 | 0.11 | - | - | - | 41 | |
| | | | | | 25' | 0.92 | 0.97 | 0.97 | 0.11 | - | - | - | 41 | |
| | | | | | 30' | 1.09 | 1.18 | 1.10 | 0.11 | - | - | - | 41 | |
| | | | | | 0.33' - <2' | 0.41 | 0.61 | 0.55 | 0.22 | 0.23 | 0.30 | 0.41 | - | |
| | | | | | 2' - <3' | 0.41 | 0.61 | 0.55 | 0.11 | - | - | - | 47 | |
| 7' x 5' | 9 | 9 | 9 | 4 to 12 | 3' - <5' | 0.37 | 0.43 | 0.47 | 0.11 | - | - | - | 43 | |
| | | | | | 5' - 10' | 0.39 | 0.41 | 0.43 | 0.11 | - | - | - | 43 | |
| | | | | | 15' | 0.56 | 0.61 | 0.63 | 0.11 | - | - | - | 41 | |
| | | | | | 20' | 0.73 | 0.82 | 0.83 | 0.11 | - | - | - | 41 | |
| | | | | | 25' | 0.90 | 1.04 | 1.06 | 0.11 | - | - | - | 41 | |
| | 9 | 9.5 | 9 | 7 to 12 | 30' | 1.06 | 1.26 | 1.19 | 0.11 | - | - | - | 41 | |
| | | | | | 0.33' - <2' | 0.42 | 0.63 | 0.58 | 0.22 | 0.24 | 0.30 | 0.42 | - | |
| | | | | | 2' - <3' | 0.42 | 0.63 | 0.58 | 0.11 | - | - | - | 59 | |
| | | | | | 3' - <5' | 0.38 | 0.45 | 0.50 | 0.11 | - | - | - | 47 | |
| | | | | | 5' - 10' | 0.41 | 0.44 | 0.47 | 0.11 | - | - | - | 43 | |
| 7' x 6' | 9 | 9 | 9 | 4 to 12 | 15' | 0.57 | 0.65 | 0.68 | 0.11 | - | - | - | 41 | |
| | | | | | 20' | 0.75 | 0.87 | 0.90 | 0.11 | - | - | - | 41 | |
| | | | | | 25' | 0.93 | 1.11 | 1.13 | 0.11 | - | - | - | 41 | |
| | | | | | 30' | 1.07 | 1.35 | 1.27 | 0.11 | - | - | - | 41 | |
| | | | | | 0.33' - <2' | 0.44 | 0.66 | 0.61 | 0.22 | 0.25 | 0.31 | 0.44 | - | |
| | 7' x 7' | 9 | 9 | 9 | 4 to 12 | 2' - <3' | 0.44 | 0.65 | 0.61 | 0.11 | - | - | - | 59 |
| | | | | | | 3' - <5' | 0.41 | 0.47 | 0.52 | 0.11 | - | - | - | 59 |
| | | | | | | 5' - 10' | 0.44 | 0.47 | 0.52 | 0.11 | - | - | - | 47 |
| | | | | | | 15' | 0.62 | 0.69 | 0.74 | 0.11 | - | - | - | 43 |
| | | | | | | 20' | 0.80 | 0.93 | 0.97 | 0.11 | - | - | - | 43 |
| 9 | | 9.5 | 9 | 7 to 12 | 25' | 0.99 | 1.18 | 1.22 | 0.11 | - | - | - | 43 | |
| | | | | | 30' | 1.12 | 1.43 | 1.36 | 0.11 | - | - | - | 41 | |

TABLE 11B - STANDARD PRECAST BOX CULVERT DESIGNS (3" COVER) - 7' SPANS

| SPAN x RISE (S) (R) (Ft.) | SLAB / WALL THICKNESS | | | | DESIGN EARTH COVER ABOVE TOP SLAB | REINFORCEMENT AREAS (sq. in./Ft.) | | | | | | | | As1 EXT. LENGTH (M) (in.) |
|---------------------------------|-----------------------|-----------------------|-----------------------|------------------------|--|--------------------------------------|------|------|------|------|------|------|-----|------------------------------------|
| | TOP (Tt) (in.) | BOT. (Tb) (in.) | SIDE (Tw) (in.) | HAUNCH (H) (in.) | | As1 | As2 | As3 | As4 | As5 | As7 | As8 | As9 | |
| | | | | | | See General Note 5 | | | | | | | | |
| 7' x 4' | 10 | 10 | 10 | 4 to 12 | 0.33' - <2' | 0.33 | 0.49 | 0.44 | 0.24 | 0.24 | 0.24 | 0.33 | - | |
| | | | | | 2' - <3' | 0.33 | 0.49 | 0.44 | 0.12 | - | - | - | 43 | |
| | | | | | 3' - <5' | 0.29 | 0.35 | 0.38 | 0.12 | - | - | - | 43 | |
| | | | | | 5' - 10' | 0.31 | 0.30 | 0.31 | 0.12 | - | - | - | 43 | |
| | | | | | 15' | 0.44 | 0.44 | 0.45 | 0.12 | - | - | - | 41 | |
| | 10 | 10 | 10 | 7 to 12 | 20' | 0.58 | 0.59 | 0.60 | 0.12 | - | - | - | 41 | |
| | | | | | 25' | 0.71 | 0.74 | 0.75 | 0.12 | - | - | - | 41 | |
| | | | | | 30' | 0.85 | 0.91 | 0.91 | 0.12 | - | - | - | 41 | |
| | | | | | 0.33' - <2' | 0.32 | 0.51 | 0.47 | 0.24 | 0.24 | 0.24 | 0.32 | - | |
| | | | | | 2' - <3' | 0.32 | 0.51 | 0.47 | 0.12 | - | - | - | 47 | |
| 7' x 5' | 10 | 10 | 10 | 4 to 12 | 3' - <5' | 0.29 | 0.37 | 0.41 | 0.12 | - | - | - | 43 | |
| | | | | | 5' - 10' | 0.31 | 0.32 | 0.35 | 0.12 | - | - | - | 43 | |
| | | | | | 15' | 0.44 | 0.47 | 0.50 | 0.12 | - | - | - | 41 | |
| | | | | | 20' | 0.57 | 0.63 | 0.65 | 0.12 | - | - | - | 41 | |
| | | | | | 25' | 0.70 | 0.80 | 0.82 | 0.12 | - | - | - | 41 | |
| | 10 | 10 | 10 | 7 to 12 | 30' | 0.84 | 0.97 | 0.99 | 0.12 | - | - | - | 41 | |
| | | | | | 0.33' - <2' | 0.33 | 0.53 | 0.50 | 0.24 | 0.24 | 0.24 | 0.33 | - | |
| | | | | | 2' - <3' | 0.33 | 0.53 | 0.50 | 0.12 | - | - | - | 59 | |
| | | | | | 3' - <5' | 0.30 | 0.38 | 0.43 | 0.12 | - | - | - | 47 | |
| | | | | | 5' - 10' | 0.33 | 0.35 | 0.38 | 0.12 | - | - | - | 43 | |
| 7' x 6' | 10 | 10 | 10 | 4 to 12 | 15' | 0.45 | 0.51 | 0.54 | 0.12 | - | - | - | 41 | |
| | | | | | 20' | 0.58 | 0.68 | 0.70 | 0.12 | - | - | - | 41 | |
| | | | | | 25' | 0.72 | 0.85 | 0.88 | 0.12 | - | - | - | 41 | |
| | | | | | 30' | 0.85 | 1.04 | 1.06 | 0.12 | - | - | - | 41 | |
| | | | | | 0.33' - <2' | 0.35 | 0.55 | 0.52 | 0.24 | 0.24 | 0.24 | 0.35 | - | |
| | 7' x 7' | 10 | 10 | 10 | 4 to 12 | 2' - <3' | 0.35 | 0.55 | 0.52 | 0.12 | - | - | - | 59 |
| | | | | | | 3' - <5' | 0.32 | 0.40 | 0.46 | 0.12 | - | - | - | 59 |
| | | | | | | 5' - 10' | 0.35 | 0.37 | 0.41 | 0.12 | - | - | - | 47 |
| | | | | | | 15' | 0.48 | 0.54 | 0.58 | 0.12 | - | - | - | 43 |
| | | | | | | 20' | 0.62 | 0.72 | 0.76 | 0.12 | - | - | - | 43 |
| 10 | | 10 | 10 | 7 to 12 | 25' | 0.76 | 0.90 | 0.94 | 0.12 | - | - | - | 43 | |
| | | | | | 30' | 0.90 | 1.10 | 1.13 | 0.12 | - | - | - | 41 | |

NOTES:

1. See Sheet 2 for General Notes.
2. See Sheet 7 for Reinforcing Details and dimension locations.
3. See Sheet 14 for WWR Bending Diagrams.

10/6/2022 10:51:22 AM

TABLE 12A - STANDARD PRECAST BOX CULVERT DESIGNS (3" COVER) - 8' SPANS

| SPAN x RISE (S) (R) (Ft.) | SLAB / WALL THICKNESS | | | | DESIGN EARTH COVER ABOVE TOP SLAB | REINFORCEMENT AREAS (sq. in./Ft.) | | | | | | | | | As1 EXT. LENGTH (M) (in.) |
|--|-----------------------|-----------------------|-----------------------|------------------------|--|--------------------------------------|-------------|------|------|------|------|------|------|------|------------------------------------|
| | TOP (Tt) (in.) | BOT. (Tb) (in.) | SIDE (Tw) (in.) | HAUNCH (H) (in.) | | As1 | As2 | As3 | As4 | As5 | As7 | As8 | As9 | | |
| | | | | | | | | | | | | | | | |
| 8' x 4' | 9 | 9 | 9 | 4 | 0.33' - <2' | 0.52 | 0.66 | 0.57 | 0.22 | 0.24 | 0.42 | 0.52 | - | | |
| | | | | 2' - <3' | 0.52 | 0.66 | 0.57 | 0.11 | - | - | - | 50 | | | |
| | | | | 3' - <5' | 0.48 | 0.49 | 0.52 | 0.11 | - | - | - | 50 | | | |
| | | | | 5' - 10' | 0.52 | 0.48 | 0.49 | 0.11 | - | - | - | 45 | | | |
| | | | | 15' | 0.75 | 0.72 | 0.72 | 0.11 | - | - | - | 41 | | | |
| | | | | 20' | 1.00 | 0.98 | 0.97 | 0.11 | - | - | - | 41 | | | |
| | 8 to 12 | 9 | 9.5 | 9 | 8 to 12 | 25' | 1.25 | 1.24 | 1.14 | 0.11 | - | - | - | 41 | |
| | | 10 | 10.5 | 9 | 12 | 30' | 1.31 | 1.29 | 1.21 | 0.11 | - | - | - | 41 | |
| | | 8' x 5' | 9 | 9 | 9 | 4 | 0.33' - <2' | 0.51 | 0.69 | 0.60 | 0.22 | 0.25 | 0.40 | 0.51 | - |
| | | | | | | 2' - <3' | 0.51 | 0.69 | 0.60 | 0.11 | - | - | - | 50 | |
| 3' - <5' | 0.46 | | | | | 0.52 | 0.56 | 0.11 | - | - | - | 45 | | | |
| 5' - 10' | 0.51 | | | | | 0.51 | 0.53 | 0.11 | - | - | - | 45 | | | |
| 15' | 0.74 | | | | | 0.77 | 0.78 | 0.11 | - | - | - | 41 | | | |
| 20' | 0.97 | | | | | 1.05 | 1.05 | 0.11 | - | - | - | 41 | | | |
| 8 to 12 | 9 | | 9.5 | 9 | 8 to 12 | 25' | 1.20 | 1.33 | 1.23 | 0.11 | - | - | - | 41 | |
| | 10 | | 10.5 | 9 | 12 | 30' | 1.26 | 1.38 | 1.30 | 0.11 | - | - | - | 41 | |
| | 8' x 6' | | 9 | 9 | 9 | 4 | 0.33' - <2' | 0.51 | 0.72 | 0.64 | 0.22 | 0.26 | 0.39 | 0.51 | - |
| | | | | | | 2' - <3' | 0.51 | 0.72 | 0.64 | 0.11 | - | - | - | 50 | |
| 3' - <5' | | 0.47 | | | | 0.55 | 0.59 | 0.11 | - | - | - | 50 | | | |
| 5' - 10' | | 0.52 | | | | 0.55 | 0.58 | 0.11 | - | - | - | 45 | | | |
| 15' | | 0.74 | | | | 0.83 | 0.85 | 0.11 | - | - | - | 41 | | | |
| 20' | | 0.97 | | | | 1.12 | 1.13 | 0.11 | - | - | - | 41 | | | |
| 8 to 12 | | 9 | 9.5 | 9 | 8 to 12 | 25' | 1.18 | 1.42 | 1.32 | 0.11 | - | - | - | 41 | |
| | | 10 | 10.5 | 9 | 12 | 30' | 1.26 | 1.46 | 1.39 | 0.11 | - | - | - | 41 | |
| | | 8' x 7' | 9 | 9 | 9 | 4 | 0.33' - <2' | 0.52 | 0.74 | 0.67 | 0.22 | 0.26 | 0.40 | 0.52 | - |
| | | | | | | 2' - <3' | 0.52 | 0.74 | 0.67 | 0.11 | - | - | - | 55 | |
| 3' - <5' | 0.49 | | | | | 0.57 | 0.62 | 0.11 | - | - | - | 55 | | | |
| 5' - 10' | 0.55 | | | | | 0.59 | 0.63 | 0.11 | - | - | - | 50 | | | |
| 15' | 0.77 | | | | | 0.88 | 0.91 | 0.11 | - | - | - | 41 | | | |
| 20' | 1.01 | | | | | 1.19 | 1.21 | 0.11 | - | - | - | 41 | | | |
| 8 to 12 | 9 | | 9.5 | 9 | 8 to 12 | 25' | 1.21 | 1.51 | 1.41 | 0.11 | - | - | - | 41 | |
| | 10 | | 10.5 | 9 | 12 | 30' | 1.31 | 1.53 | 1.47 | 0.11 | - | - | - | 41 | |
| | 8' x 8' | | 9 | 9 | 9 | 4 | 0.33' - <2' | 0.55 | 0.77 | 0.70 | 0.22 | 0.27 | 0.41 | 0.55 | - |
| | | | | | | 2' - <3' | 0.55 | 0.77 | 0.70 | 0.13 | - | - | - | 65 | |
| 3' - <5' | | 0.53 | | | | 0.59 | 0.64 | 0.12 | - | - | - | 65 | | | |
| 5' - 10' | | 0.60 | | | | 0.63 | 0.68 | 0.11 | - | - | - | 55 | | | |
| 15' | | 0.83 | | | | 0.93 | 0.98 | 0.11 | - | - | - | 45 | | | |
| 20' | | 1.08 | | | | 1.26 | 1.29 | 0.11 | - | - | - | 45 | | | |
| 8 to 12 | | 9 | 9.5 | 9 | 8 to 12 | 25' | 1.28 | 1.59 | 1.50 | 0.11 | - | - | - | 41 | |
| | | 10 | 10.5 | 9 | 12 | 30' | 1.41 | 1.61 | 1.55 | 0.11 | - | - | - | 41 | |

See General Note 5

TABLE 12B - STANDARD PRECAST BOX CULVERT DESIGNS (3" COVER) - 8' SPANS

| SPAN x RISE (S) (R) (Ft.) | SLAB / WALL THICKNESS | | | | DESIGN EARTH COVER ABOVE TOP SLAB | REINFORCEMENT AREAS (sq. in./Ft.) | | | | | | | | | As1 EXT. LENGTH (M) (in.) |
|--|-----------------------|-----------------------|-----------------------|------------------------|--|--------------------------------------|-------------|------|------|------|------|-------|------|------|------------------------------------|
| | TOP (Tt) (in.) | BOT. (Tb) (in.) | SIDE (Tw) (in.) | HAUNCH (H) (in.) | | As1 | As2 | As3 | As4 | As5 | As7 | As8 | As9 | | |
| | | | | | | | | | | | | | | | |
| 8' x 4' | 10 | 10 | 10 | 4 | 0.33' - <2' | 0.42 | 0.56 | 0.49 | 0.24 | 0.24 | 0.32 | 0.41 | - | | |
| | | | | 2' - <3' | 0.42 | 0.56 | 0.49 | 0.12 | - | - | - | 50 | | | |
| | | | | 3' - <5' | 0.38 | 0.42 | 0.46 | 0.12 | - | - | - | 50 | | | |
| | | | | 5' - 10' | 0.41 | 0.38 | 0.39 | 0.12 | - | - | - | 45 | | | |
| | | | | 15' | 0.59 | 0.56 | 0.57 | 0.12 | - | - | - | 41 | | | |
| | | | | 20' | 0.78 | 0.75 | 0.76 | 0.12 | - | - | - | 41 | | | |
| | 8 to 12 | 10 | 10.5 | 10 | 8 to 12 | 25' | 0.97 | 0.96 | 0.96 | 0.12 | - | - | - | 41 | |
| | | 10 | 10.5 | 10 | 12 | 30' | 1.15 | 1.16 | 1.10 | 0.12 | - | - | - | 41 | |
| | | 8' x 5' | 10 | 10 | 10 | 4 | 0.33' - <2' | 0.40 | 0.58 | 0.52 | 0.24 | 0.034 | 0.31 | 0.40 | - |
| | | | | | | 2' - <3' | 0.40 | 0.58 | 0.52 | 0.12 | - | - | - | 50 | |
| 3' - <5' | 0.37 | | | | | 0.45 | 0.48 | 0.12 | - | - | - | 45 | | | |
| 5' - 10' | 0.41 | | | | | 0.41 | 0.43 | 0.12 | - | - | - | 45 | | | |
| 15' | 0.58 | | | | | 0.60 | 0.62 | 0.12 | - | - | - | 41 | | | |
| 20' | 0.76 | | | | | 0.81 | 0.81 | 0.12 | - | - | - | 41 | | | |
| 8 to 12 | 10 | | 10.5 | 10 | 8 to 12 | 25' | 0.94 | 1.03 | 1.03 | 0.12 | - | - | - | 41 | |
| | 10 | | 10.5 | 10 | 12 | 30' | 1.10 | 1.24 | 1.24 | 0.12 | - | - | - | 41 | |
| | 8' x 6' | | 10 | 10 | 10 | 4 | 0.33' - <2' | 0.40 | 0.60 | 0.55 | 0.24 | 0.24 | 0.30 | 0.40 | - |
| | | | | | | 2' - <3' | 0.40 | 0.60 | 0.55 | 0.12 | - | - | - | 50 | |
| 3' - <5' | | 0.37 | | | | 0.47 | 0.51 | 0.12 | - | - | - | 50 | | | |
| 5' - 10' | | 0.42 | | | | 0.43 | 0.46 | 0.12 | - | - | - | 45 | | | |
| 15' | | 0.58 | | | | 0.64 | 0.67 | 0.12 | - | - | - | 41 | | | |
| 20' | | 0.76 | | | | 0.86 | 0.88 | 0.12 | - | - | - | 41 | | | |
| 8 to 12 | | 10 | 10.5 | 10 | 8 to 12 | 25' | 0.94 | 1.09 | 1.11 | 0.12 | - | - | - | 41 | |
| | | 10 | 10.5 | 10 | 12 | 30' | 1.09 | 1.32 | 1.26 | 0.12 | - | - | - | 41 | |
| | | 8' x 7' | 10 | 10 | 10 | 4 | 0.33' - <2' | 0.41 | 0.63 | 0.58 | 0.24 | 0.24 | 0.30 | 0.41 | - |
| | | | | | | 2' - <3' | 0.41 | 0.63 | 0.58 | 0.12 | - | - | - | 55 | |
| 3' - <5' | 0.39 | | | | | 0.49 | 0.53 | 0.12 | - | - | - | 55 | | | |
| 5' - 10' | 0.44 | | | | | 0.46 | 0.50 | 0.12 | - | - | - | 50 | | | |
| 15' | 0.61 | | | | | 0.68 | 0.72 | 0.12 | - | - | - | 45 | | | |
| 20' | 0.78 | | | | | 0.91 | 0.94 | 0.12 | - | - | - | 41 | | | |
| 8 to 12 | 10 | | 10.5 | 10 | 8 to 12 | 25' | 0.97 | 1.16 | 1.18 | 0.12 | - | - | - | 41 | |
| | 10 | | 10.5 | 10 | 12 | 30' | 1.11 | 1.40 | 1.34 | 0.12 | - | - | - | 41 | |
| | 8' x 8' | | 10 | 10 | 10 | 4 | 0.33' - <2' | 0.44 | 0.64 | 0.60 | 0.24 | 0.24 | 0.31 | 0.44 | - |
| | | | | | | 2' - <3' | 0.44 | 0.64 | 0.60 | 0.12 | - | - | - | 65 | |
| 3' - <5' | | 0.42 | | | | 0.51 | 0.56 | 0.12 | - | - | - | 65 | | | |
| 5' - 10' | | 0.47 | | | | 0.50 | 0.55 | 0.12 | - | - | - | 55 | | | |
| 15' | | 0.65 | | | | 0.72 | 0.77 | 0.12 | - | - | - | 45 | | | |
| 20' | | 0.84 | | | | 0.96 | 1.01 | 0.12 | - | - | - | 45 | | | |
| 8 to 12 | | 10 | 10.5 | 10 | 8 to 12 | 25' | 1.03 | 1.22 | 1.26 | 0.12 | - | - | - | 41 | |
| | | 10 | 10.5 | 10 | 12 | 30' | 1.16 | 1.47 | 1.42 | 0.12 | - | - | - | 41 | |

See General Note 5

NOTES:

1. See Sheet 2 for General Notes.
2. See Sheet 7 for Reinforcing Details and dimension locations.
3. See Sheet 14 for WWR Bending Diagrams.

10/6/2022 10:51:22 AM

TABLE 13A - STANDARD PRECAST BOX CULVERT DESIGNS (3" COVER) - 9' SPANS

| SPAN x RISE (S) (R) (Ft.) | SLAB / WALL THICKNESS | | | | DESIGN EARTH COVER ABOVE TOP SLAB | REINFORCEMENT AREAS (sq. in./Ft.) | | | | | | | | As1 EXT. LENGTH (M) (in.) |
|------------------------------------|-----------------------|-----------------------|-----------------------|------------------------|--|--------------------------------------|------|------|-------------|------|------|------|------|------------------------------------|
| | TOP (Tt) (in.) | BOT. (Tb) (in.) | SIDE (Tw) (in.) | HAUNCH (H) (in.) | | As1 | As2 | As3 | As4 | As5 | As7 | As8 | As9 | |
| | | | | | | As1 | As2 | As3 | As4 | As5 | As7 | As8 | As9 | |
| 9' x 5' | 9 | 9 | 9 | 4 | 0.33' - <2' | 0.62 | 0.78 | 0.65 | 0.22 | 0.26 | 0.52 | 0.61 | - | |
| | | | | to | 2' - <3' | 0.62 | 0.78 | 0.65 | 0.11 | - | - | - | 54 | |
| | | | | 12 | 3' - <5' | 0.58 | 0.63 | 0.61 | 0.11 | - | - | - | 49 | |
| | | | | 15' | 0.65 | 0.63 | 0.64 | 0.11 | - | - | - | 49 | | |
| | | | | 20' | 0.95 | 0.96 | 0.95 | 0.11 | - | - | - | 44 | | |
| | | | | 25' | 1.26 | 1.32 | 1.28 | 0.11 | - | - | - | 44 | | |
| | 10 | 10.5 | 9 | 8 | 25' | 1.39 | 1.41 | 1.32 | 0.11 | - | - | - | 44 | |
| | | | | to | 30' | 1.46 | 1.50 | 1.42 | 0.11 | - | - | - | 44 | |
| | | | | 12 | 0.33' - <2' | 0.60 | 0.81 | 0.69 | 0.22 | 0.27 | 0.51 | 0.60 | - | |
| | | | | 4 | 2' - <3' | 0.60 | 0.81 | 0.69 | 0.11 | - | - | - | 54 | |
| | | | | to | 3' - <5' | 0.56 | 0.66 | 0.65 | 0.11 | - | - | - | 49 | |
| | | | | 12 | 5' - 10' | 0.65 | 0.68 | 0.69 | 0.11 | - | - | - | 49 | |
| 9 | 9 | 9 | 8 | 15' | 0.94 | 1.03 | 1.02 | 0.11 | - | - | - | 44 | | |
| | | | to | 20' | 1.25 | 1.40 | 1.38 | 0.11 | - | - | - | 44 | | |
| | | | 12 | 25' | 1.37 | 1.49 | 1.40 | 0.11 | - | - | - | 44 | | |
| | | | 10 | 10.5 | 9 | 25' | 1.37 | 1.49 | 1.40 | 0.11 | - | - | - | 44 |
| | | | to | 30' | 1.44 | 1.58 | 1.50 | 0.11 | - | - | - | 44 | | |
| | | | 12 | 0.33' - <2' | 0.61 | 0.84 | 0.72 | 0.22 | 0.28 | 0.51 | 0.61 | - | | |
| 9' x 7' | 9 | 9 | 9 | 4 | 2' - <3' | 0.61 | 0.83 | 0.72 | 0.11 | - | - | - | 59 | |
| | | | | to | 3' - <5' | 0.58 | 0.69 | 0.68 | 0.11 | - | - | - | 54 | |
| | | | | 12 | 5' - 10' | 0.67 | 0.73 | 0.75 | 0.11 | - | - | - | 49 | |
| | | | | 15' | 0.96 | 1.09 | 1.10 | 0.11 | - | - | - | 44 | | |
| | | | | 20' | 1.27 | 1.49 | 1.47 | 0.11 | - | - | - | 44 | | |
| | | | | 25' | 1.38 | 1.57 | 1.48 | 0.11 | - | - | - | 44 | | |
| | 10 | 10.5 | 9 | 8 | 30' | 1.49 | 1.70 | 1.58 | 0.11 | - | - | - | 44 | |
| | | | | to | 0.33' - <2' | 0.60 | 0.85 | 0.73 | 0.22 | 0.29 | 0.52 | 0.53 | - | |
| | | | | 12 | 2' - <3' | 0.64 | 0.86 | 0.76 | 0.12 | - | - | - | 59 | |
| | | | | 4 | 3' - <5' | 0.62 | 0.72 | 0.72 | 0.11 | - | - | - | 59 | |
| | | | | to | 5' - 10' | 0.71 | 0.77 | 0.81 | 0.11 | - | - | - | 54 | |
| | | | | 12 | 15' | 1.01 | 1.16 | 1.17 | 0.11 | - | - | - | 44 | |
| 9 | 9.5 | 9 | 8 | 20' | 1.27 | 1.56 | 1.45 | 0.11 | - | - | - | 44 | | |
| | | | to | 25' | 1.45 | 1.65 | 1.57 | 0.11 | - | - | - | 44 | | |
| | | | 12 | 30' | 1.59 | 1.72 | 1.66 | 0.11 | - | - | - | 44 | | |
| | | | 4 | 0.33' - <2' | 0.68 | 0.88 | 0.76 | 0.22 | 0.29 | 0.55 | 0.57 | - | | |
| | | | to | 2' - <3' | 0.68 | 0.88 | 0.78 | 0.18 | - | - | - | 72 | | |
| | | | 12 | 3' - <5' | 0.68 | 0.75 | 0.78 | 0.18 | - | - | - | 72 | | |
| 9 | 9 | 9 | 8 | 5' - 10' | 0.79 | 0.82 | 0.88 | 0.17 | - | - | - | 59 | | |
| | | | to | 15' | 1.11 | 1.22 | 1.26 | 0.13 | - | - | - | 49 | | |
| | | | 12 | 20' | 1.37 | 1.64 | 1.54 | 0.13 | - | - | - | 49 | | |
| | | | 10 | 10.5 | 9 | 25' | 1.56 | 1.73 | 1.65 | 0.13 | - | - | - | 44 |
| | | | to | 30' | 1.56 | 1.73 | 1.68 | 0.12 | - | - | - | 44 | | |
| | | | 12 | 9' x 8' | 9 | 9 | 9 | 4 | 0.33' - <2' | 0.60 | 0.85 | 0.73 | 0.22 | 0.29 |

See General Note 5

TABLE 13B - STANDARD PRECAST BOX CULVERT DESIGNS (3" COVER) - 9' SPANS

| SPAN x RISE (S) (R) (Ft.) | SLAB / WALL THICKNESS | | | | DESIGN EARTH COVER ABOVE TOP SLAB | REINFORCEMENT AREAS (sq. in./Ft.) | | | | | | | | As1 EXT. LENGTH (M) (in.) |
|------------------------------------|-----------------------|-----------------------|-----------------------|------------------------|--|--------------------------------------|------|------|-------------|------|------|------|------|------------------------------------|
| | TOP (Tt) (in.) | BOT. (Tb) (in.) | SIDE (Tw) (in.) | HAUNCH (H) (in.) | | As1 | As2 | As3 | As4 | As5 | As7 | As8 | As9 | |
| | | | | | | As1 | As2 | As3 | As4 | As5 | As7 | As8 | As9 | |
| 9' x 5' | 10 | 10 | 10 | 4 | 0.33' - <2' | 0.49 | 0.65 | 0.57 | 0.24 | 0.24 | 0.40 | 0.48 | - | |
| | | | | to | 2' - <3' | 0.49 | 0.65 | 0.57 | 0.12 | - | - | - | 54 | |
| | | | | 12 | 3' - <5' | 0.46 | 0.54 | 0.53 | 0.12 | - | - | - | 49 | |
| | | | | 15' | 0.52 | 0.50 | 0.51 | 0.12 | - | - | - | 49 | | |
| | | | | 20' | 0.75 | 0.74 | 0.75 | 0.12 | - | - | - | 44 | | |
| | | | | 25' | 0.98 | 1.01 | 1.00 | 0.12 | - | - | - | 44 | | |
| | 10 | 10.5 | 10 | 8 to | 25' | 1.21 | 1.27 | 1.19 | 0.12 | - | - | - | 44 | |
| | | | | to | 30' | 1.30 | 1.36 | 1.30 | 0.12 | - | - | - | 44 | |
| | | | | 12 | 0.33' - <2' | 0.48 | 0.68 | 0.60 | 0.24 | 0.24 | 0.39 | 0.48 | - | |
| | | | | 4 | 2' - <3' | 0.48 | 0.68 | 0.60 | 0.12 | - | - | - | 54 | |
| | | | | to | 3' - <5' | 0.45 | 0.57 | 0.56 | 0.12 | - | - | - | 49 | |
| | | | | 12 | 5' - 10' | 0.52 | 0.53 | 0.56 | 0.12 | - | - | - | 49 | |
| 9 | 9 | 9 | 8 | 15' | 0.74 | 0.79 | 0.81 | 0.12 | - | - | - | 44 | | |
| | | | to | 20' | 0.97 | 1.07 | 1.07 | 0.12 | - | - | - | 44 | | |
| | | | 12 | 25' | 1.18 | 1.35 | 1.28 | 0.12 | - | - | - | 44 | | |
| | | | 10 | 10.5 | 10 | 25' | 1.18 | 1.35 | 1.28 | 0.12 | - | - | - | 44 |
| | | | to | 30' | 1.27 | 1.44 | 1.38 | 0.12 | - | - | - | 44 | | |
| | | | 12 | 0.33' - <2' | 0.49 | 0.70 | 0.63 | 0.24 | 0.24 | 0.39 | 0.49 | - | | |
| 9' x 7' | 10 | 10 | 10 | 4 | 2' - <3' | 0.49 | 0.70 | 0.63 | 0.12 | - | - | - | 59 | |
| | | | | to | 3' - <5' | 0.46 | 0.59 | 0.59 | 0.12 | - | - | - | 54 | |
| | | | | 12 | 5' - 10' | 0.54 | 0.57 | 0.60 | 0.12 | - | - | - | 49 | |
| | | | | 15' | 0.75 | 0.84 | 0.86 | 0.12 | - | - | - | 44 | | |
| | | | | 20' | 0.98 | 1.13 | 1.14 | 0.12 | - | - | - | 44 | | |
| | | | | 25' | 1.18 | 1.43 | 1.36 | 0.12 | - | - | - | 44 | | |
| | 10 | 10.5 | 10 | 8 to | 30' | 1.28 | 1.52 | 1.46 | 0.12 | - | - | - | 44 | |
| | | | | to | 0.33' - <2' | 0.51 | 0.72 | 0.65 | 0.24 | 0.24 | 0.39 | 0.51 | - | |
| | | | | 12 | 2' - <3' | 0.51 | 0.72 | 0.65 | 0.12 | - | - | - | 59 | |
| | | | | 4 | 3' - <5' | 0.49 | 0.61 | 0.62 | 0.12 | - | - | - | 59 | |
| | | | | to | 5' - 10' | 0.57 | 0.60 | 0.65 | 0.12 | - | - | - | 54 | |
| | | | | 12 | 15' | 0.79 | 0.89 | 0.92 | 0.12 | - | - | - | 44 | |
| 9 | 9.5 | 9 | 8 | 20' | 1.02 | 1.20 | 1.22 | 0.12 | - | - | - | 44 | | |
| | | | to | 25' | 1.21 | 1.50 | 1.44 | 0.12 | - | - | - | 44 | | |
| | | | 12 | 30' | 1.33 | 1.59 | 1.54 | 0.12 | - | - | - | 44 | | |
| | | | 4 | 0.33' - <2' | 0.54 | 0.74 | 0.68 | 0.24 | 0.24 | 0.41 | 0.54 | - | | |
| | | | to | 2' - <3' | 0.54 | 0.74 | 0.68 | 0.15 | - | - | - | 72 | | |
| | | | 12 | 3' - <5' | 0.53 | 0.63 | 0.64 | 0.13 | - | - | - | 72 | | |
| 9 | 9 | 9 | 8 | 5' - 10' | 0.62 | 0.64 | 0.70 | 0.12 | - | - | - | 59 | | |
| | | | to | 15' | 0.85 | 0.94 | 0.99 | 0.12 | - | - | - | 49 | | |
| | | | 12 | 20' | 1.09 | 1.26 | 1.29 | 0.12 | - | - | - | 49 | | |
| | | | 10 | 10.5 | 10 | 25' | 1.28 | 1.56 | 1.52 | 0.12 | - | - | - | 44 |
| | | | to | 30' | 1.42 | 1.66 | 1.66 | 0.12 | - | - | - | 44 | | |
| | | | 12 | 9' x 8' | 10 | 10 | 10 | 4 | 0.33' - <2' | 0.51 | 0.72 | 0.65 | 0.24 | 0.24 |

See General Note 5

NOTES:

1. See Sheet 2 for General Notes.
2. See Sheet 7 for Reinforcing Details and dimension locations.
3. See Sheet 14 for WWR Bending Diagrams.

10/16/2022 10:51:23 AM

TABLE 14 - STANDARD PRECAST BOX CULVERT DESIGNS (3" COVER) - 10' SPANS

| SPAN x RISE (S) (R) (Ft.) | SLAB / WALL THICKNESS | | | | DESIGN EARTH COVER ABOVE TOP SLAB | REINFORCEMENT AREAS (sq. in./Ft.) | | | | | | | | | As1 EXT. LENGTH (M) (in.) | | |
|---------------------------------|-----------------------|-----------------------|-----------------------|------------------------|--|--------------------------------------|------|-------------|-------------|------|------|------|------|------|------------------------------------|------|---|
| | TOP (Tt) (in.) | BOT. (Tb) (in.) | SIDE (Tw) (in.) | HAUNCH (H) (in.) | | As1 | As2 | As3 | As4 | As5 | As7 | As8 | As9 | | | | |
| | | | | | | As1 | As2 | As3 | As4 | As5 | As7 | As8 | As9 | | | | |
| 10' x 5' | 10 | 10 | 10 | 4 | 0.33' - <2' | 0.60 | 0.73 | 0.61 | 0.24 | 0.24 | 0.50 | 0.57 | - | | | | |
| | | | | to | 2' - <3' | 0.60 | 0.73 | 0.61 | 0.12 | - | - | - | 58 | | | | |
| | | | | 12 | 3' - <5' | 0.57 | 0.64 | 0.58 | 0.12 | - | - | - | 53 | | | | |
| | | | | 8 | 5' - 10' | 0.65 | 0.60 | 0.60 | 0.12 | - | - | - | 52 | | | | |
| | | | | to | 15' | 0.94 | 0.90 | 0.89 | 0.12 | - | - | - | 47 | | | | |
| | | | | 12 | 20' | 1.24 | 1.23 | 1.19 | 0.12 | - | - | - | 47 | | | | |
| | 10 | 10 | 10 | 10 | 8 | 25' | 1.39 | 1.37 | 1.28 | 0.12 | - | - | - | 47 | | | |
| | | | | | to | 30' | 1.38 | 1.43 | 1.41 | 0.12 | - | - | - | 47 | | | |
| | | | | | 11 | 11.5 | 11 | 12 | 0.33' - <2' | 0.58 | 0.75 | 0.64 | 0.24 | 0.24 | 0.48 | 0.56 | - |
| | | | | | to | 2' | 0.58 | 0.75 | 0.64 | 0.12 | - | - | - | 58 | | | |
| | | | | | 12 | 3' | 0.56 | 0.67 | 0.62 | 0.12 | - | - | - | 52 | | | |
| | | | | | 8 | 5' | 0.64 | 0.64 | 0.65 | 0.12 | - | - | - | 52 | | | |
| 10 | 10 | 10 | 10 | 8 | 15' | 0.92 | 0.96 | 0.95 | 0.12 | - | - | - | 47 | | | | |
| | | | | to | 20' | 1.21 | 1.31 | 1.27 | 0.12 | - | - | - | 47 | | | | |
| | | | | 12 | 25' | 1.35 | 1.44 | 1.36 | 0.12 | - | - | - | 47 | | | | |
| | | | | to | 30' | 1.35 | 1.51 | 1.49 | 0.12 | - | - | - | 47 | | | | |
| | | | | 11 | 11.5 | 11 | 12 | 0.33' - <2' | 0.57 | 0.78 | 0.67 | 0.24 | 0.24 | 0.48 | 0.57 | - | |
| | | | | 12 | 12.5 | 12 | 12 | 2' | 0.57 | 0.78 | 0.67 | 0.12 | - | - | - | 58 | |
| 10' x 7' | 10 | 10 | 10 | 4 | 3' | 0.58 | 0.70 | 0.65 | 0.12 | - | - | - | 58 | | | | |
| | | | | to | 5' | 0.65 | 0.68 | 0.70 | 0.12 | - | - | - | 52 | | | | |
| | | | | 12 | 15' | 0.92 | 1.02 | 1.02 | 0.12 | - | - | - | 47 | | | | |
| | | | | 8 | 20' | 1.21 | 1.38 | 1.35 | 0.12 | - | - | - | 47 | | | | |
| | | | | to | 25' | 1.33 | 1.52 | 1.44 | 0.12 | - | - | - | 47 | | | | |
| | | | | 12 | 30' | 1.38 | 1.58 | 1.57 | 0.12 | - | - | - | 47 | | | | |
| | 10 | 10 | 10 | 10 | 8 | 0.33' - <2' | 0.58 | 0.80 | 0.70 | 0.24 | 0.26 | 0.48 | 0.58 | - | | | |
| | | | | | to | 2' | 0.58 | 0.80 | 0.70 | 0.12 | - | - | - | 64 | | | |
| | | | | | 12 | 3' | 0.60 | 0.72 | 0.68 | 0.12 | - | - | - | 58 | | | |
| | | | | | 8 | 5' | 0.67 | 0.72 | 0.75 | 0.12 | - | - | - | 52 | | | |
| | | | | | to | 15' | 0.95 | 1.08 | 1.08 | 0.12 | - | - | - | 47 | | | |
| | | | | | 12 | 20' | 1.24 | 1.45 | 1.44 | 0.12 | - | - | - | 47 | | | |
| 10 | 10 | 10 | 10 | 8 | 25' | 1.36 | 1.59 | 1.52 | 0.12 | - | - | - | 47 | | | | |
| | | | | to | 30' | 1.45 | 1.64 | 1.64 | 0.12 | - | - | - | 47 | | | | |
| | | | | 11 | 11.5 | 11 | 12 | 0.33' - <2' | 0.61 | 0.82 | 0.73 | 0.24 | 0.26 | 0.50 | 0.61 | - | |
| | | | | 12 | 12.5 | 12 | 12 | 2' | 0.61 | 0.82 | 0.73 | 0.14 | - | - | - | 70 | |
| | | | | 8 | 3' | 0.64 | 0.75 | 0.73 | 0.13 | - | - | - | 64 | | | | |
| | | | | 12 | 5' | 0.72 | 0.77 | 0.80 | 0.12 | - | - | - | 58 | | | | |
| 10' x 9' | 10 | 10 | 10 | 4 | 15' | 1.00 | 1.13 | 1.15 | 0.12 | - | - | - | 52 | | | | |
| | | | | to | 20' | 1.30 | 1.53 | 1.52 | 0.12 | - | - | - | 47 | | | | |
| | | | | 12 | 25' | 1.42 | 1.66 | 1.60 | 0.12 | - | - | - | 47 | | | | |
| | | | | 8 | 30' | 1.57 | 1.70 | 1.72 | 0.12 | - | - | - | 47 | | | | |
| | | | | to | 0.33' - <2' | 0.66 | 0.84 | 0.75 | 0.24 | 0.27 | 0.52 | 0.65 | - | | | | |
| | | | | 12 | 2' | 0.66 | 0.84 | 0.75 | 0.20 | - | - | - | 79 | | | | |
| | 10 | 10 | 10 | 10 | 4 | 3' | 0.70 | 0.77 | 0.79 | 0.19 | - | - | - | 70 | | | |
| | | | | | to | 5' | 0.79 | 0.81 | 0.87 | 0.18 | - | - | - | 64 | | | |
| | | | | | 12 | 15' | 1.09 | 1.19 | 1.23 | 0.15 | - | - | - | 52 | | | |
| | | | | | 8 | 20' | 1.40 | 1.61 | 1.61 | 0.14 | - | - | - | 52 | | | |
| | | | | | to | 25' | 1.53 | 1.74 | 1.68 | 0.14 | - | - | - | 47 | | | |
| | | | | | 12 | 30' | 1.60 | 1.71 | 1.74 | 0.14 | - | - | - | 47 | | | |

See General Note 5

TABLE 15 - STANDARD PRECAST BOX CULVERT DESIGNS (3" COVER) - 11' SPANS

| SPAN x RISE (S) (R) (Ft.) | SLAB / WALL THICKNESS | | | | DESIGN EARTH COVER ABOVE TOP SLAB | REINFORCEMENT AREAS (sq. in./Ft.) | | | | | | | | | As1 EXT. LENGTH (M) (in.) | | | |
|---------------------------------|-----------------------|-----------------------|-----------------------|------------------------|--|--------------------------------------|------|------|-------------|-------------|------|------|------|------|------------------------------------|------|------|---|
| | TOP (Tt) (in.) | BOT. (Tb) (in.) | SIDE (Tw) (in.) | HAUNCH (H) (in.) | | As1 | As2 | As3 | As4 | As5 | As7 | As8 | As9 | | | | | |
| | | | | | | As1 | As2 | As3 | As4 | As5 | As7 | As8 | As9 | | | | | |
| 11' x 4' | 11 | 11 | 11 | 4 | 0.33' - <2' | 0.60 | 0.66 | 0.54 | 0.27 | 0.27 | 0.52 | 0.56 | - | | | | | |
| | | | | to | 2' | 0.60 | 0.66 | 0.54 | 0.14 | - | - | - | 62 | | | | | |
| | | | | 12 | 3' | 0.60 | 0.61 | 0.53 | 0.14 | - | - | - | 62 | | | | | |
| | | | | 8 | 5' | 0.79 | 0.63 | 0.62 | 0.14 | - | - | - | 55 | | | | | |
| | | | | to | 15' | 1.01 | 0.82 | 0.79 | 0.14 | - | - | - | 55 | | | | | |
| | | | | 12 | 20' | 1.34 | 1.11 | 1.06 | 0.14 | - | - | - | 55 | | | | | |
| | 11 | 11 | 11 | 11 | 8 | 25' | 1.52 | 1.27 | 1.23 | 0.14 | - | - | - | 55 | | | | |
| | | | | | to | 30' | 1.54 | 1.37 | 1.34 | 0.14 | - | - | - | 50 | | | | |
| | | | | | 12 | 12 | 12 | 11 | 4 | 0.33' - <2' | 0.57 | 0.71 | 0.60 | 0.27 | 0.27 | 0.47 | 0.53 | - |
| | | | | | to | 2' | 0.56 | 0.71 | 0.60 | 0.14 | - | - | - | 62 | | | | |
| | | | | | 12 | 3' | 0.56 | 0.67 | 0.59 | 0.14 | - | - | - | 55 | | | | |
| | | | | | 8 | 5' | 0.73 | 0.71 | 0.72 | 0.14 | - | - | - | 55 | | | | |
| 11 | 11 | 11 | 11 | 8 | 15' | 0.92 | 0.92 | 0.91 | 0.14 | - | - | - | 50 | | | | | |
| | | | | to | 20' | 1.21 | 1.25 | 1.21 | 0.14 | - | - | - | 50 | | | | | |
| | | | | 12 | 25' | 1.37 | 1.43 | 1.39 | 0.14 | - | - | - | 50 | | | | | |
| | | | | to | 30' | 1.39 | 1.53 | 1.50 | 0.14 | - | - | - | 50 | | | | | |
| | | | | 11 | 11 | 11 | 11 | 4 | 0.33' - <2' | 0.55 | 0.76 | 0.66 | 0.27 | 0.27 | 0.46 | 0.55 | - | |
| | | | | 12 | 12.5 | 11 | 12 | 2' | 0.55 | 0.76 | 0.66 | 0.14 | - | - | - | 62 | | |
| 11' x 8' | 11 | 11 | 11 | 4 | 3' | 0.54 | 0.72 | 0.65 | 0.14 | - | - | - | 62 | | | | | |
| | | | | to | 5' | 0.73 | 0.79 | 0.82 | 0.14 | - | - | - | 55 | | | | | |
| | | | | 12 | 15' | 0.93 | 1.03 | 1.03 | 0.14 | - | - | - | 50 | | | | | |
| | | | | 8 | 20' | 1.21 | 1.39 | 1.36 | 0.14 | - | - | - | 50 | | | | | |
| | | | | to | 25' | 1.34 | 1.56 | 1.50 | 0.14 | - | - | - | 50 | | | | | |
| | | | | 12 | 30' | 1.41 | 1.66 | 1.65 | 0.14 | - | - | - | 50 | | | | | |
| | 11 | 11 | 11 | 11 | 8 | 0.33' - <2' | 0.60 | 0.81 | 0.71 | 0.27 | 0.27 | 0.48 | 0.60 | - | | | | |
| | | | | | to | 2' | 0.60 | 0.81 | 0.71 | 0.15 | - | - | - | 75 | | | | |
| | | | | | 12 | 3' | 0.61 | 0.77 | 0.70 | 0.14 | - | - | - | 69 | | | | |
| | | | | | 8 | 5' | 0.80 | 0.88 | 0.93 | 0.14 | - | - | - | 62 | | | | |
| | | | | | to | 15' | 1.01 | 1.13 | 1.15 | 0.14 | - | - | - | 55 | | | | |
| | | | | | 12 | 20' | 1.30 | 1.52 | 1.52 | 0.14 | - | - | - | 50 | | | | |
| 11 | 11 | 11 | 11 | 8 | 25' | 1.42 | 1.70 | 1.65 | 0.14 | - | - | - | 50 | | | | | |
| | | | | to | 30' | 1.53 | 1.77 | 1.74 | 0.14 | - | - | - | 50 | | | | | |
| | | | | 11 | 11 | 11 | 11 | 4 | 0.33' - <2' | 0.64 | 0.83 | 0.74 | 0.27 | 0.27 | 0.51 | 0.64 | - | |
| | | | | 12 | 12.5 | 11 | 12 | 2' | 0.64 | 0.83 | 0.74 | 0.21 | - | - | - | 86 | | |
| | | | | 8 | 3' | 0.67 | 0.79 | 0.75 | 0.21 | - | - | - | 75 | | | | | |
| | | | | 12 | 5' | 0.88 | 0.93 | 0.99 | 0.19 | - | - | - | 69 | | | | | |
| 11 | 11 | 11 | 11 | 8 | 15' | 1.09 | 1.19 | 1.23 | 0.16 | - | - | - | 55 | | | | | |
| | | | | to | 20' | 1.40 | 1.59 | 1.60 | 0.15 | - | - | - | 55 | | | | | |
| | | | | 12 | 25' | 1.54 | 1.77 | 1.73 | 0.15 | - | - | - | 50 | | | | | |
| | | | | to | 30' | 1.57 | 1.77 | 1.76 | 0.14 | - | - | - | 50 | | | | | |
| | | | | 11 | 11 | 11 | 11 | 4 | 0.33' - <2' | 0.64 | 0.83 | 0.74 | 0.27 | 0.27 | 0.51 | 0.64 | - | |
| | | | | 12 | 12.5 | 11 | 12 | 2' | 0.64 | 0.83 | 0.74 | 0.21 | - | - | - | 86 | | |

See General Note 5

NOTES:

1. See Sheet 2 for General Notes.
2. See Sheet 7 for Reinforcing Details and dimension locations.
3. See Sheet 14 for WWR Bending Diagrams.

10/6/2022 10:51:24 AM

TABLE 16 - STANDARD PRECAST BOX CULVERT DESIGNS (3" COVER) - 12' SPANS

| SPAN x RISE (S) (R) (Ft.) | SLAB / WALL THICKNESS | | | | DESIGN EARTH COVER ABOVE TOP SLAB | REINFORCEMENT AREAS (sq. in./Ft.) | | | | | | | | As1 EXT. LENGTH (M) (in.) |
|------------------------------------|-----------------------|-----------------------|-----------------------|------------------------|--|--------------------------------------|------|------|------|------|------|------|-----|------------------------------------|
| | TOP (Tt) (in.) | BOT. (Tb) (in.) | SIDE (Tw) (in.) | HAUNCH (H) (in.) | | As1 | As2 | As3 | As4 | As5 | As7 | As8 | As9 | |
| 12' x 4' | 12 | 12 | 12 | 4 | 0.33' - <2' | 0.59 | 0.64 | 0.51 | 0.29 | 0.29 | 0.52 | 0.55 | - | |
| | | | | to | 2' - <3' | 0.60 | 0.64 | 0.51 | 0.15 | - | - | - | 73 | |
| | | | | | 3' - <5' | 0.60 | 0.61 | 0.51 | 0.15 | - | - | - | 66 | |
| | | | | | 5' - 10' | 0.81 | 0.61 | 0.61 | 0.15 | - | - | - | 66 | |
| | | | | 12 | 15' | 1.04 | 0.80 | 0.77 | 0.15 | - | - | - | 59 | |
| | | | | | 20' | 1.37 | 1.08 | 1.03 | 0.15 | - | - | - | 59 | |
| | 13 | 13 | 12 | 8 to | 25' | 1.58 | 1.26 | 1.21 | 0.15 | - | - | - | 59 | |
| | 14.5 | 14.5 | 12 | 12 | 30' | 1.63 | 1.38 | 1.34 | 0.15 | - | - | - | 53 | |
| 12' x 6' | 12 | 12 | 12 | 4 | 0.33' - <2' | 0.56 | 0.70 | 0.57 | 0.29 | 0.29 | 0.47 | 0.52 | - | |
| | | | | to | 2' - <3' | 0.56 | 0.70 | 0.57 | 0.15 | - | - | - | 66 | |
| | | | | | 3' - <5' | 0.56 | 0.67 | 0.57 | 0.15 | - | - | - | 59 | |
| | | | | | 5' - 10' | 0.74 | 0.69 | 0.70 | 0.15 | - | - | - | 59 | |
| | | | | 12 | 15' | 0.94 | 0.90 | 0.88 | 0.15 | - | - | - | 53 | |
| | | | | | 20' | 1.23 | 1.22 | 1.17 | 0.15 | - | - | - | 53 | |
| | 13 | 13 | 12 | 8 to | 25' | 1.40 | 1.42 | 1.37 | 0.15 | - | - | - | 53 | |
| | 14.5 | 15 | 12 | 12 | 30' | 1.44 | 1.54 | 1.48 | 0.15 | - | - | - | 53 | |
| 12' x 8' | 12 | 12 | 12 | 4 | 0.33' - <2' | 0.55 | 0.75 | 0.63 | 0.29 | 0.29 | 0.45 | 0.53 | - | |
| | | | | to | 2' - <3' | 0.55 | 0.75 | 0.63 | 0.15 | - | - | - | 66 | |
| | | | | | 3' - <5' | 0.55 | 0.73 | 0.63 | 0.15 | - | - | - | 59 | |
| | | | | | 5' - 10' | 0.73 | 0.77 | 0.79 | 0.15 | - | - | - | 59 | |
| | | | | 12 | 15' | 0.93 | 1.00 | 0.99 | 0.15 | - | - | - | 53 | |
| | | | | | 20' | 1.21 | 1.35 | 1.31 | 0.15 | - | - | - | 53 | |
| | 13 | 13.5 | 12 | to | 25' | 1.35 | 1.55 | 1.48 | 0.15 | - | - | - | 53 | |
| | 14.5 | 15 | 12 | 12 | 30' | 1.40 | 1.67 | 1.62 | 0.15 | - | - | - | 53 | |
| 12' x 10' | 12 | 12 | 12 | 4 | 0.33' - <2' | 0.57 | 0.80 | 0.68 | 0.29 | 0.29 | 0.46 | 0.57 | - | |
| | | | | to | 2' - <3' | 0.57 | 0.80 | 0.68 | 0.15 | - | - | - | 73 | |
| | | | | | 3' - <5' | 0.59 | 0.77 | 0.68 | 0.15 | - | - | - | 66 | |
| | | | | | 5' - 10' | 0.78 | 0.85 | 0.89 | 0.15 | - | - | - | 59 | |
| | | | | 12 | 15' | 0.98 | 1.10 | 1.11 | 0.15 | - | - | - | 53 | |
| | | | | | 20' | 1.26 | 1.47 | 1.45 | 0.15 | - | - | - | 53 | |
| | 13 | 13.5 | 12 | to | 25' | 1.39 | 1.68 | 1.63 | 0.15 | - | - | - | 53 | |
| | 14.5 | 15 | 12 | 12 | 30' | 1.48 | 1.79 | 1.76 | 0.15 | - | - | - | 53 | |
| 12' x 12' | 12 | 12 | 12 | 4 | 0.33' - <2' | 0.65 | 0.84 | 0.73 | 0.29 | 0.29 | 0.50 | 0.65 | - | |
| | | | | to | 2' - <3' | 0.65 | 0.84 | 0.73 | 0.23 | - | - | - | 93 | |
| | | | | | 3' - <5' | 0.68 | 0.81 | 0.75 | 0.22 | - | - | - | 80 | |
| | | | | | 5' - 10' | 0.90 | 0.94 | 1.01 | 0.21 | - | - | - | 73 | |
| | | | | 12 | 15' | 1.12 | 1.20 | 1.24 | 0.18 | - | - | - | 59 | |
| | | | | | 20' | 1.42 | 1.60 | 1.61 | 0.16 | - | - | - | 59 | |
| | 13 | 13.5 | 12 | to | 25' | 1.57 | 1.81 | 1.78 | 0.16 | - | - | - | 53 | |
| | 14.5 | 15 | 12.5 | 12 | 30' | 1.63 | 1.86 | 1.85 | 0.15 | - | - | - | 53 | |

See General Note 5

NOTES:

1. See Sheet 2 of 14 for General Notes.
2. See Sheet 7 of 14 for Reinforcing Details and dimension locations.

WELDED WIRE REINFORCEMENT BENDING DIAGRAM

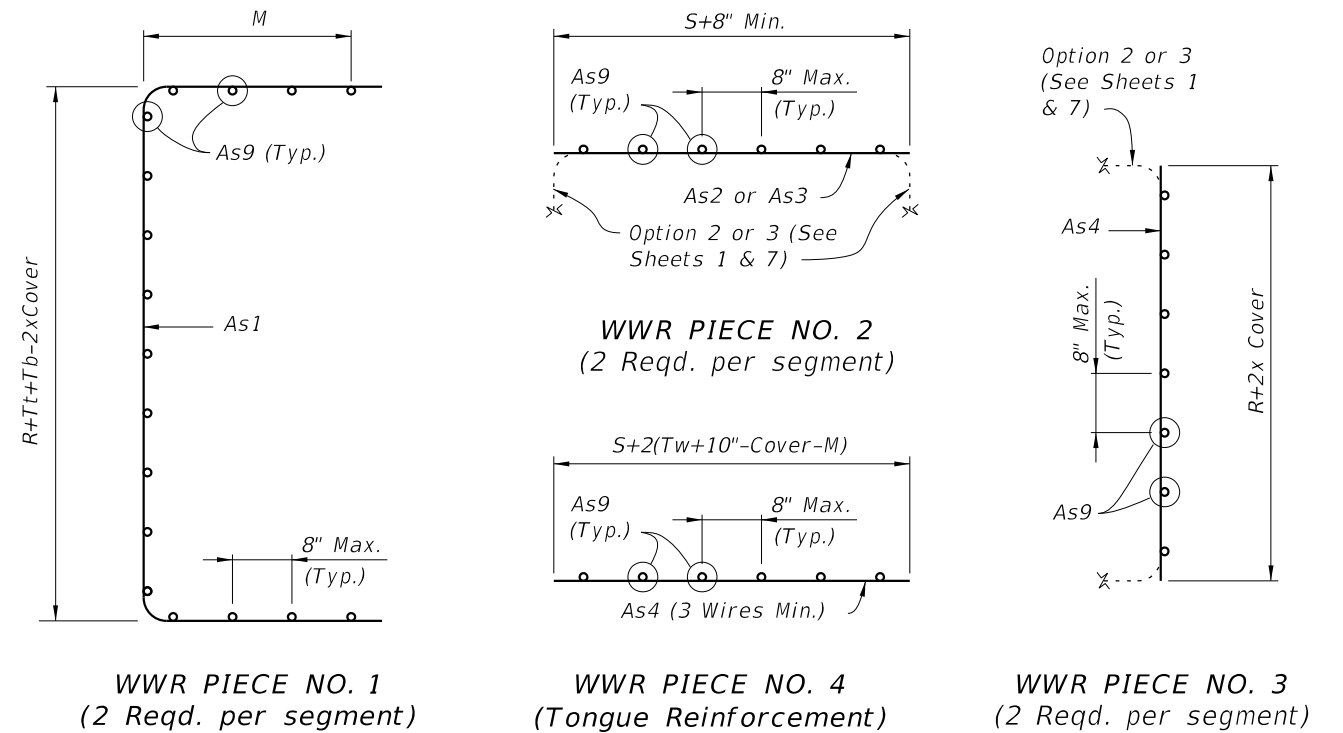

TYPE 2 BOX SECTION (DESIGN EARTH COVER 2' OR GREATER)

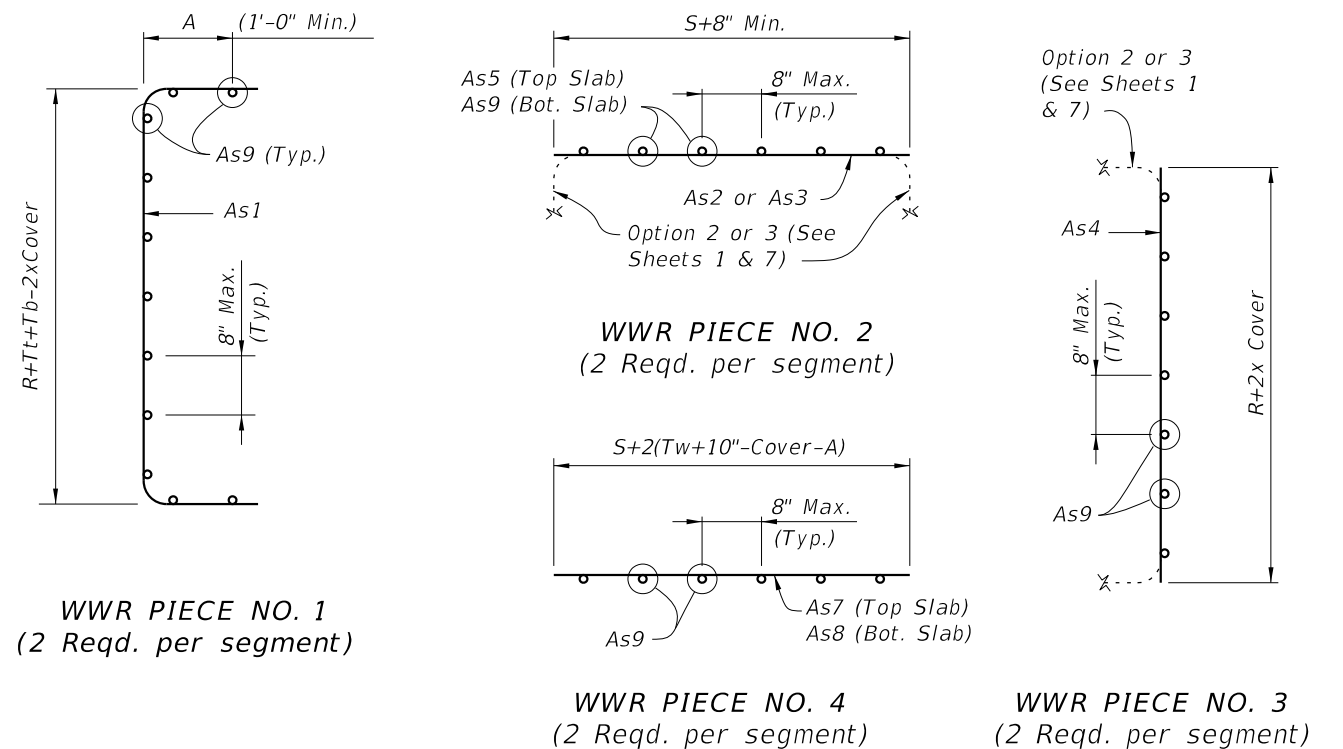

TYPE 1 BOX SECTION (DESIGN EARTH COVER LESS THAN 2')

REINFORCEMENT NOTES:

1. Reinforcement bending dimensions are out-to-out.
2. See General Notes 4, 5 and 6 on Sheet 2.
3. See Tables 1 thru 16 for dimensions M, R, S, Tb, Tt and Tw.
4. Dimension "A" is determined by the Manufacturer in accordance with the requirements of Detail "B" on Sheets 1 and 7.

| | |
|---------------------------|--------------|
| LAST REVISION 07/01/13 | DESCRIPTION: |
|---------------------------|--------------|