

PLAN

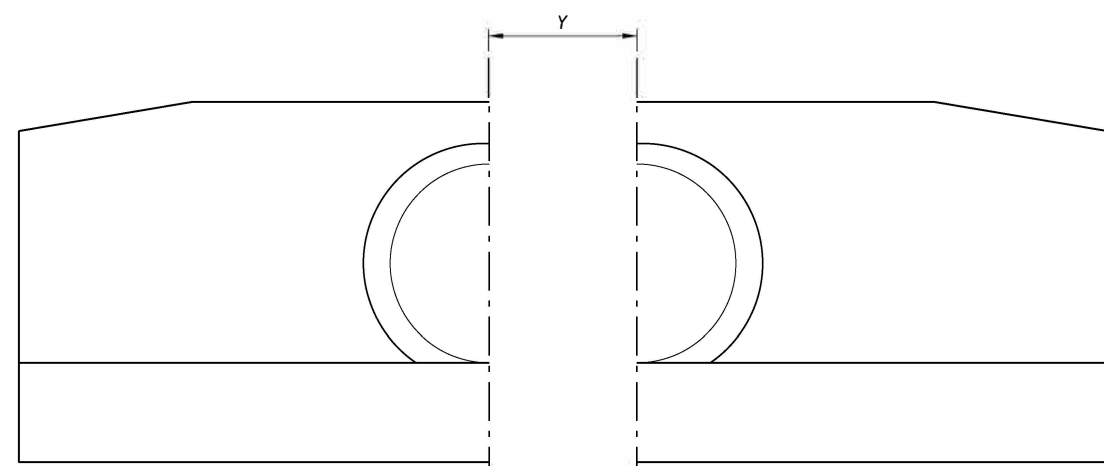

FRONT ELEVATION

NORMAL PIPE

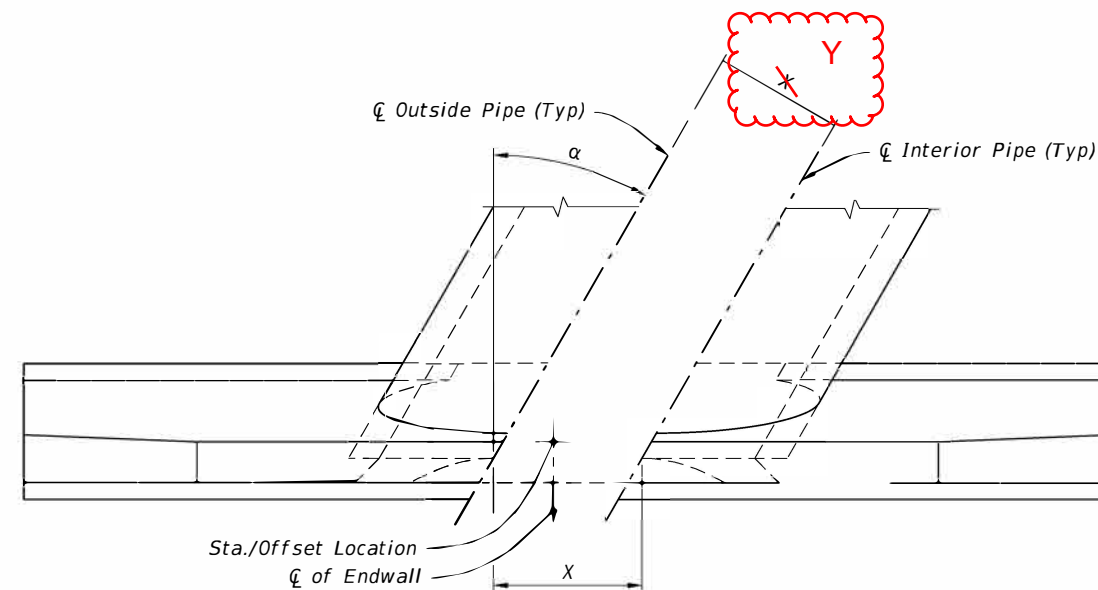

PLAN

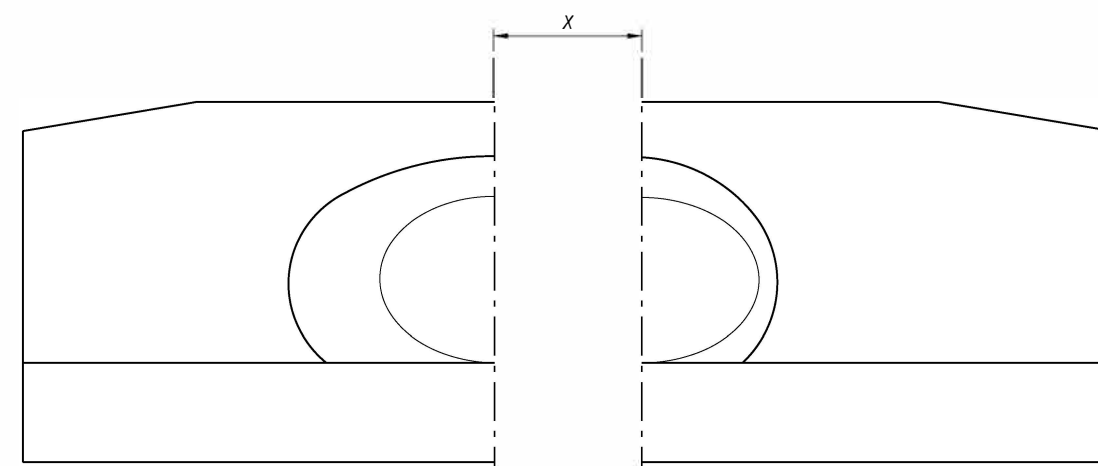

FRONT ELEVATION

SKEWED PIPE

(Multiple Pipe Shown, Single Pipe Similar)

LEGEND:

- α Pipe Skew Angle
- Y Center to Center between pipes
- X Center to Center along front of Headwall

SPACING FOR MULTIPLE PIPES

10/6/2022 1:55:02 PM

| | | |
|---------------------------|----------|--------------|
| LAST REVISION 11/01/19 | REVISION | DESCRIPTION: |
|---------------------------|----------|--------------|



FY 2023-24
STANDARD PLANS

STRAIGHT CONCRETE ENDWALLS
SINGLE AND MULTIPLE PIPE

INDEX
430-030

SHEET
4 of 4